



**THE DATASHEET OF  
TS5A1066DBVR**

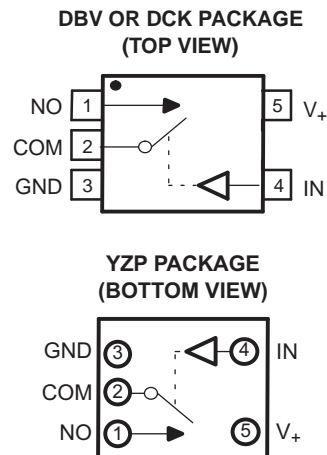


## 10-Ω SPST ANALOG SWITCH

Check for Samples: [TS5A1066](#)

### FEATURES

- Low ON-State Resistance (10 Ω)
- Control Inputs Are 5.5-V Tolerant
- Low Charge Injection
- Low Total Harmonic Distortion (THD)
- 1.65-V to 5.5-V Single-Supply Operation
- Latch-Up Performance Exceeds 100 mA Per JESD 78, Class II
- ESD Performance Tested Per JESD 22
  - 2000-V Human-Body Model (A114-B, Class II)
  - 1000-V Charged-Device Model (C101)



### DESCRIPTION/ORDERING INFORMATION

The TS5A1066 is a single-pole single-throw (SPST) analog switch that is designed to operate from 1.65 V to 5.5 V. This device can handle both digital and analog signals, and signals up to  $V_+$  (peak) can be transmitted in either direction.

**Table 1. SUMMARY OF CHARACTERISTICS**

Configuration	Single-Pole, Single-Throw Demultiplexer (1 × SPST)
Number of channels	1
ON-state resistance ( $r_{on}$ )	7.5 Ω
ON-state resistance flatness ( $r_{on(Flat)}$ )	2.5 Ω
Turn-on/turn-off time ( $t_{ON}/t_{OFF}$ )	9.5 ns/2 ns
Charge injection ( $Q_C$ )	1 pC
Bandwidth (BW)	400 MHz
OFF isolation ( $O_{ISO}$ )	–68 dB at 10 MHz
Total harmonic distortion (THD)	0.14%
Leakage current ( $I_{COM(OFF)}$ )	±0.1 μA
Power-supply current ( $I_+$ )	0.05 μA
Package options	5-pin DSBGA, SOT-23, or SC-70



Please be aware that an important notice concerning availability, standard warranty, and use in critical applications of Texas Instruments semiconductor products and disclaimers thereto appears at the end of this data sheet.

**Table 2. ORDERING INFORMATION**

T <sub>A</sub>	PACKAGE <sup>(1)</sup>		ORDERABLE PART NUMBER	TOP-SIDE MARKING <sup>(2)</sup>
-40°C to 85°C	NanoFree™ – WCSP (DSBGA) 0.23-mm Large Bump – YZP (Pb-free)	Tape and reel	TS5A1066YZPR	JD_
	SOT (SOT-23) – DBV	Tape and reel	TS5A1066DBVR	JAD_
	SOT (SC-70) – DCK	Tape and reel	TS5A1066DCKR	JD_

- (1) Package drawings, standard packing quantities, thermal data, symbolization, and PCB design guidelines are available at [www.ti.com/sc/package](http://www.ti.com/sc/package).
- (2) DBV/DCK: The actual top-side marking has one additional character that designates the assembly/test site.  
YZP: The actual top-side marking has three preceding characters to denote year, month, and sequence code, and one following character to designate the assembly/test site. Pin 1 identifier indicates solder-bump composition (1 = SnPb, • = Pb-free).

**FUNCTION TABLE**

IN	NO TO COM, COM TO NO
L	OFF
H	ON

**Absolute Minimum and Maximum Rating<sup>(1) (2)</sup>**

over operating free-air temperature range (unless otherwise noted)

		MIN	MAX	UNIT
V <sub>+</sub>	Supply voltage range <sup>(3)</sup>	-0.5	6.5	V
V <sub>NO</sub> V <sub>COM</sub>	Analog voltage range <sup>(3) (4) (5)</sup>	-0.5	V <sub>+</sub> + 0.5	V
I <sub>K</sub>	Analog port diode current	V <sub>NO</sub> , V <sub>COM</sub> < 0 or V <sub>NO</sub> , V <sub>COM</sub> > V <sub>+</sub>		mA
I <sub>NO</sub> I <sub>COM</sub>	On-state switch current	V <sub>NO</sub> , V <sub>COM</sub> = 0 to V <sub>+</sub>		mA
V <sub>I</sub>	Digital input voltage range <sup>(3) (4)</sup>	-0.5	6.5	V
I <sub>IK</sub>	Digital input clamp current	V <sub>I</sub> < 0		mA
I <sub>+</sub> I <sub>GND</sub>	Continuous current through each V <sub>+</sub> or GND	-100	100	mA
θ <sub>JA</sub>	Package thermal impedance <sup>(6)</sup>	DBV package		206
		DCK package		252
		YZP package		132
T <sub>stg</sub>	Storage temperature range	-65	150	°C

- (1) Stresses beyond those listed under "absolute maximum ratings" may cause permanent damage to the device. These are stress ratings only, and functional operation of the device at these or any other conditions beyond those indicated under "recommended operating conditions" is not implied. Exposure to absolute-maximum-rated conditions for extended periods may affect device reliability.
- (2) The algebraic convention, whereby the most negative value is a minimum and the most positive value is a maximum.
- (3) All voltages are with respect to ground, unless otherwise specified.
- (4) The input and output voltage ratings may be exceeded if the input and output clamp-current ratings are observed.
- (5) This value is limited to 5.5 V maximum.
- (6) The package thermal impedance is calculated in accordance with JESD 51-7.

**Electrical Characteristics for 5-V Supply<sup>(1)</sup>**
 $V_+ = 4.5\text{ V to }5.5\text{ V}$ ,  $T_A = -40^\circ\text{C to }85^\circ\text{C}$  (unless otherwise noted)

PARAMETER	SYMBOL	TEST CONDITIONS	$T_A$	$V_+$	MIN	TYP	MAX	UNIT
<b>Analog Switch</b>								
Analog signal range	$V_{COM}, V_{NO}$				0		$V_+$	V
ON-state resistance	$r_{on}$	$0 \leq V_{NO} \leq V_+$ , $I_{COM} = -30\text{ mA}$ , Switch ON, See Figure 13	25°C Full	4.5 V		7.5	10 12	$\Omega$
ON-state resistance flatness	$r_{on(Flat)}$	$0 \leq V_{NO} \leq V_+$ , $I_{COM} = -30\text{ mA}$ , Switch ON, See Figure 13	25°C Full	4.5 V		2.5	5 6	$\Omega$
NO OFF leakage current	$I_{NO(OFF)}$	$V_{NO} = 1\text{ V}$ , $V_{COM} = 4.5\text{ V}$ , or $V_{NO} = 4.5\text{ V}$ , $V_{COM} = 1\text{ V}$ , Switch OFF, See Figure 14	25°C Full	5.5 V	-0.2	0.1	0.2 2	$\mu\text{A}$
COM OFF leakage current	$I_{COM(OFF)}$	$V_{COM} = 1\text{ V}$ , $V_{NO} = 4.5\text{ V}$ , or $V_{COM} = 4.5\text{ V}$ , $V_{NO} = 1\text{ V}$ , Switch OFF, See Figure 14	25°C Full	5.5 V	-0.1	0.05	0.1 0.2	$\mu\text{A}$
NO ON leakage current	$I_{NO(ON)}$	$V_{NO} = 1\text{ V}$ , $V_{COM} = \text{Open}$ , or $V_{NO} = 4.5\text{ V}$ , $V_{COM} = \text{Open}$ , Switch ON, See Figure 15	25°C Full	5.5 V	-0.2	0.1	0.2 2	$\mu\text{A}$
COM ON leakage current	$I_{COM(ON)}$	$V_{COM} = 1\text{ V}$ , $V_{NO} = \text{Open}$ , or $V_{COM} = 4.5\text{ V}$ , $V_{NO} = \text{Open}$ , Switch ON, See Figure 15	25°C Full	5.5 V	-0.1	0.05	0.1 0.2	$\mu\text{A}$
<b>Digital Control Input (IN)</b>								
Input logic high	$V_{IH}$		Full		$V_+ \times 0.7$		5.5	V
Input logic low	$V_{IL}$		Full		0		$V_+ \times 0.3$	V
Input leakage current	$I_{IH}, I_{IL}$	$V_I = 5.5\text{ V or }0$	25°C Full	5.5 V	-0.1	0.05	0.1 1	$\mu\text{A}$

(1) The algebraic convention is used in this data sheet; the most negative value is shown in the minimum column.

**Electrical Characteristics for 5-V Supply<sup>(1)</sup> (continued)**
 $V_+ = 4.5\text{ V to }5.5\text{ V}$ ,  $T_A = -40^\circ\text{C to }85^\circ\text{C}$  (unless otherwise noted)

PARAMETER	SYMBOL	TEST CONDITIONS		$T_A$	$V_+$	MIN	TYP	MAX	UNIT
<b>Dynamic</b>									
Turn-on time	$t_{ON}$	$V_{COM} = 3\text{ V}$ , $R_L = 300\ \Omega$ ,	$C_L = 35\text{ pF}$ , See Figure 17	25°C	5 V	3.5	4.8	5.5	ns
				Full	4.5 V to 5.5 V	3.5		7.5	
Turn-off time	$t_{OFF}$	$V_{COM} = 3\text{ V}$ , $R_L = 300\ \Omega$ ,	$C_L = 35\text{ pF}$ , See Figure 17	25°C	5 V	2	3	4.5	ns
				Full	4.5 V to 5.5 V	2		5.5	
Charge injection	$Q_C$	$V_{GEN} = 0$ , $C_L = 0.1\text{ nF}$ ,	See Figure 20	25°C	5 V		1		pC
NO OFF capacitance	$C_{NO(OFF)}$	$V_{NO} = V_+$ or GND, Switch OFF,	See Figure 16	25°C	5 V		6.8		pF
COM OFF capacitance	$C_{COM(OFF)}$	$V_{COM} = V_+$ or GND, Switch OFF,	See Figure 16	25°C	5 V		6.8		pF
NO ON capacitance	$C_{NO(ON)}$	$V_{NO} = V_+$ or GND, Switch ON,	See Figure 16	25°C	5 V		14		pF
COM ON capacitance	$C_{COM(ON)}$	$V_{COM} = V_+$ or GND, Switch ON,	See Figure 16	25°C	5 V		14		pF
Digital input capacitance	$C_I$	$V_I = V_+$ or GND,	See Figure 16	25°C	5 V		2.2		pF
Bandwidth	BW	$R_L = 50\ \Omega$ , Switch ON,	See Figure 18	25°C	5 V		400		MHz
OFF isolation	$O_{ISO}$	$R_L = 50\ \Omega$ , $f = 10\text{ MHz}$ ,	Switch OFF, See Figure 19	25°C	5 V		-68		dB
Total harmonic distortion	THD	$R_L = 600\ \Omega$ , $C_L = 50\text{ pF}$ ,	$f = 20\text{ Hz to }20\text{ kHz}$ , See Figure 21	25°C	5 V		0.14		%
<b>Supply</b>									
Positive supply current	$I_+$	$V_I = V_+$ or GND,	Switch ON or OFF	25°C	5.5 V		0.05	1	$\mu\text{A}$
				Full				5	

**Electrical Characteristics for 3.3-V Supply<sup>(1)</sup>**
 $V_+ = 3\text{ V to }3.6\text{ V}$ ,  $T_A = -40^\circ\text{C to }85^\circ\text{C}$  (unless otherwise noted)

PARAMETER	SYMBOL	TEST CONDITIONS	$T_A$	$V_+$	MIN	TYP	MAX	UNIT
<b>Analog Switch</b>								
Analog signal range	$V_{COM}, V_{NO}$				0		$V_+$	V
ON-state resistance	$r_{on}$	$0 \leq V_{NO} \leq V_+$ , $I_{COM} = -24\text{ mA}$ , Switch ON, See Figure 13	25°C Full	3 V		11.5	14	$\Omega$
ON-state resistance flatness	$r_{on(flat)}$	$0 \leq V_{NO} \leq V_+$ , $I_{COM} = -24\text{ mA}$ , Switch ON, See Figure 13	25°C Full	3 V		5	10	$\Omega$
NO OFF leakage current	$I_{NO(OFF)}$	$V_{NO} = 1\text{ V}$ , $V_{COM} = 3\text{ V}$ , or $V_{NO} = 3\text{ V}$ , $V_{COM} = 1\text{ V}$ , Switch OFF, See Figure 14	25°C Full	3.6 V	-0.2	0.1	0.2	$\mu\text{A}$
COM OFF leakage current	$I_{COM(OFF)}$	$V_{COM} = 1\text{ V}$ , $V_{NO} = 3\text{ V}$ , or $V_{COM} = 3\text{ V}$ , $V_{NO} = 1\text{ V}$ , Switch OFF, See Figure 14	25°C Full	3.6 V	-0.1	0.05	0.1	$\mu\text{A}$
NO ON leakage current	$I_{NO(ON)}$	$V_{NO} = 1\text{ V}$ , $V_{COM} = \text{Open}$ , or $V_{NO} = 3\text{ V}$ , $V_{COM} = \text{Open}$ , Switch ON, See Figure 15	25°C Full	3.6 V	-0.2	0.1	0.2	$\mu\text{A}$
COM ON leakage current	$I_{COM(ON)}$	$V_{COM} = 1\text{ V}$ , $V_{NO} = \text{Open}$ , or $V_{COM} = 3\text{ V}$ , $V_{NO} = \text{Open}$ , Switch ON, See Figure 15	25°C Full	3.6 V	-0.1	0.05	0.1	$\mu\text{A}$
<b>Digital Control Input (IN)</b>								
Input logic high	$V_{IH}$		Full		$V_+ \times 0.7$		5.5	V
Input logic low	$V_{IL}$		Full		0		$V_+ \times 0.3$	V
Input leakage current	$I_{IH}, I_{IL}$	$V_I = 5.5\text{ V or }0$	25°C Full	3.6 V	-0.1	0.05	0.1	$\mu\text{A}$
					-1		1	

(1) The algebraic convention is used in this data sheet; the most negative value is shown in the minimum column.

**Electrical Characteristics for 3.3-V Supply<sup>(1)</sup> (continued)**
 $V_+ = 3\text{ V to }3.6\text{ V}$ ,  $T_A = -40^\circ\text{C to }85^\circ\text{C}$  (unless otherwise noted)

PARAMETER	SYMBOL	TEST CONDITIONS	$T_A$	$V_+$	MIN	TYP	MAX	UNIT	
<b>Dynamic</b>									
Turn-on time	$t_{ON}$	$V_{COM} = 2\text{ V}$ , $R_L = 300\ \Omega$ ,	$C_L = 35\text{ pF}$ , See Figure 17	25°C	3.3 V	4.5	5.5	8	ns
				Full	3 V to 3.6 V	4.5		8.5	
Turn-off time	$t_{OFF}$	$V_{COM} = 2\text{ V}$ , $R_L = 300\ \Omega$ ,	$C_L = 35\text{ pF}$ , See Figure 17	25°C	3.3 V	2	3	4.5	ns
				Full	3 V to 3.6 V	2		5.5	
Charge injection	$Q_C$	$V_{GEN} = 0$ , $C_L = 0.1\text{ nF}$ ,	See Figure 20	25°C	3.3 V	1		pC	
NO OFF capacitance	$C_{NO(OFF)}$	$V_{NO} = V_+$ or GND, Switch OFF,	See Figure 16	25°C	3.3 V	6.8		pF	
COM OFF capacitance	$C_{COM(OFF)}$	$V_{COM} = V_+$ or GND, Switch OFF,	See Figure 16	25°C	3.3 V	6.8		pF	
NO ON capacitance	$C_{NO(ON)}$	$V_{NO} = V_+$ or GND, Switch ON,	See Figure 16	25°C	3.3 V	14		pF	
COM ON capacitance	$C_{COM(ON)}$	$V_{COM} = V_+$ or GND, Switch ON,	See Figure 16	25°C	3.3 V	14		pF	
Digital input capacitance	$C_I$	$V_I = V_+$ or GND,	See Figure 16	25°C	3.3 V	2.2		pF	
Bandwidth	BW	$R_L = 50\ \Omega$ , Switch ON,	See Figure 18	25°C	3.3 V	400		MHz	
OFF isolation	$O_{ISO}$	$R_L = 50\ \Omega$ , $f = 10\text{ MHz}$ ,	Switch OFF, See Figure 19	25°C	3.3 V	-68		dB	
Total harmonic distortion	THD	$R_L = 600\ \Omega$ , $C_L = 50\text{ pF}$ ,	$f = 20\text{ Hz to }20\text{ kHz}$ , See Figure 21	25°C	3.3 V	0.2		%	
<b>Supply</b>									
Positive supply current	$I_+$	$V_I = V_+$ or GND,	Switch ON or OFF	25°C	3.6 V	0.05	1	$\mu\text{A}$	
				Full			5		

**Electrical Characteristics for 2.5-V Supply<sup>(1)</sup>**
 $V_+ = 2.3 \text{ V to } 2.7 \text{ V}$ ,  $T_A = -40^\circ\text{C to } 85^\circ\text{C}$  (unless otherwise noted)

PARAMETER	SYMBOL	TEST CONDITIONS	$T_A$	$V_+$	MIN	TYP	MAX	UNIT
<b>Analog Switch</b>								
Analog signal range	$V_{\text{COM}}, V_{\text{NO}}$				0		$V_+$	V
ON-state resistance	$r_{\text{on}}$	$0 \leq V_{\text{NO}} \leq V_+$ , $I_{\text{COM}} = -8 \text{ mA}$ , Switch ON, See Figure 13	25°C	2.3 V	20		24	$\Omega$
			Full				27	
ON-state resistance flatness	$r_{\text{on(flat)}}$	$0 \leq V_{\text{NO}} \leq V_+$ , $I_{\text{COM}} = -8 \text{ mA}$ , Switch ON, See Figure 13	25°C	2.3 V	7.5		15	$\Omega$
			Full				20	
NO OFF leakage current	$I_{\text{NO(OFF)}}$	$V_{\text{NO}} = 0.5 \text{ V}$ , $V_{\text{COM}} = 2.2 \text{ V}$ , or $V_{\text{NO}} = 2.2 \text{ V}$ , $V_{\text{COM}} = 0.5 \text{ V}$ , Switch OFF, See Figure 14	25°C	2.7 V	-0.2	0.1	0.2	$\mu\text{A}$
			Full		-2		2	
COM OFF leakage current	$I_{\text{COM(OFF)}}$	$V_{\text{COM}} = 0.5 \text{ V}$ , $V_{\text{NO}} = 2.2 \text{ V}$ , or $V_{\text{COM}} = 2.2 \text{ V}$ , $V_{\text{NO}} = 0.5 \text{ V}$ , Switch OFF, See Figure 14	25°C	2.7 V	-0.1	0.05	0.1	$\mu\text{A}$
			Full		-0.2		0.2	
NO ON leakage current	$I_{\text{NO(ON)}}$	$V_{\text{NO}} = 0.5 \text{ V}$ , $V_{\text{COM}} = \text{Open}$ , or $V_{\text{NO}} = 2.2 \text{ V}$ , $V_{\text{COM}} = \text{Open}$ , Switch ON, See Figure 15	25°C	2.7 V	-0.2	0.1	0.2	$\mu\text{A}$
			Full		-2		2	
COM ON leakage current	$I_{\text{COM(ON)}}$	$V_{\text{COM}} = 0.5 \text{ V}$ , $V_{\text{NO}} = \text{Open}$ , or $V_{\text{COM}} = 2.2 \text{ V}$ , $V_{\text{NO}} = \text{Open}$ , Switch ON, See Figure 15	25°C	2.7 V	-0.1	0.05	0.1	$\mu\text{A}$
			Full		-0.2		0.2	
<b>Digital Control Input (IN)</b>								
Input logic high	$V_{\text{IH}}$		Full		$V_+ \times 0.7$		5.5	V
Input logic low	$V_{\text{IL}}$		Full		0	$V_+ \times 0.3$		V
Input leakage current	$I_{\text{IH}}, I_{\text{IL}}$	$V_I = 5.5 \text{ V or } 0$	25°C	2.7 V	-0.1	0.05	0.1	$\mu\text{A}$
			Full		-1		1	

(1) The algebraic convention is used in this data sheet; the most negative value is shown in the minimum column.

**Electrical Characteristics for 2.5-V Supply<sup>(1)</sup> (continued)**
 $V_+ = 2.3 \text{ V to } 2.7 \text{ V}$ ,  $T_A = -40^\circ\text{C to } 85^\circ\text{C}$  (unless otherwise noted)

PARAMETER	SYMBOL	TEST CONDITIONS	$T_A$	$V_+$	MIN	TYP	MAX	UNIT
<b>Dynamic</b>								
Turn-on time	$t_{ON}$	$V_{COM} = 1.5 \text{ V}$ , $R_L = 300 \Omega$ , $C_L = 35 \text{ pF}$ , See Figure 17	25°C	2.5 V	4.5	5.5	8	ns
			Full	2.3 V to 2.7 V	4.5		8.5	
Turn-off time	$t_{OFF}$	$V_{COM} = 1.5 \text{ V}$ , $R_L = 300 \Omega$ , $C_L = 35 \text{ pF}$ , See Figure 17	25°C	2.5 V	1.5	2.5	4	ns
			Full	2.3 V to 2.7 V	1.5		5.5	
Charge injection	$Q_C$	$V_{GEN} = 0$ , $C_L = 0.1 \text{ nF}$ , See Figure 20	25°C	2.5 V		1		pC
NO OFF capacitance	$C_{NO(OFF)}$	$V_{NO} = V_+$ or GND, Switch OFF, See Figure 16	25°C	2.5 V		6.8		pF
COM OFF capacitance	$C_{COM(OFF)}$	$V_{COM} = V_+$ or GND, Switch OFF, See Figure 16	25°C	2.5 V		6.8		pF
NO ON capacitance	$C_{NO(ON)}$	$V_{NO} = V_+$ or GND, Switch ON, See Figure 16	25°C	2.5 V		14		pF
COM ON capacitance	$C_{COM(ON)}$	$V_{COM} = V_+$ or GND, Switch ON, See Figure 16	25°C	2.5 V		14		pF
Digital input capacitance	$C_I$	$V_I = V_+$ or GND, See Figure 16	25°C	2.5 V		2.2		pF
Bandwidth	BW	$R_L = 50 \Omega$ , Switch ON, See Figure 18	25°C	2.5 V		400		MHz
OFF isolation	$O_{ISO}$	$R_L = 50 \Omega$ , $f = 10 \text{ MHz}$ , Switch OFF, See Figure 19	25°C	2.5 V		-68		dB
Total harmonic distortion	THD	$R_L = 600 \Omega$ , $C_L = 50 \text{ pF}$ , $f = 20 \text{ Hz to } 20 \text{ kHz}$ , See Figure 21	25°C	2.5 V		0.32		%
<b>Supply</b>								
Positive supply current	$I_+$	$V_I = V_+$ or GND, Switch ON or OFF	25°C	2.7 V	0.05		1	$\mu\text{A}$
			Full				5	

**Electrical Characteristics for 1.8-V Supply<sup>(1)</sup>**
 $V_+ = 1.65\text{ V to }1.95\text{ V}$ ,  $T_A = -40^\circ\text{C to }85^\circ\text{C}$  (unless otherwise noted)

PARAMETER	SYMBOL	TEST CONDITIONS	$T_A$	$V_+$	MIN	TYP	MAX	UNIT
<b>Analog Switch</b>								
Analog signal range	$V_{COM}, V_{NO}$				0		$V_+$	V
ON-state resistance	$r_{on}$	$0 \leq V_{NO} \leq V_+$ , $I_{COM} = -4\text{ mA}$ , Switch ON, See Figure 13	25°C Full	1.65 V		74.5	80 100	$\Omega$
ON-state resistance flatness	$r_{on(flat)}$	$0 \leq V_{NO} \leq V_+$ , $I_{COM} = -4\text{ mA}$ , Switch ON, See Figure 13	25°C Full	1.65 V		64.5	70 90	$\Omega$
NO OFF leakage current	$I_{NO(OFF)}$	$V_{NO} = 0.3\text{ V}$ , $V_{COM} = 1.65\text{ V}$ , or $V_{NO} = 1.65\text{ V}$ , $V_{COM} = 0.3\text{ V}$ , Switch OFF, See Figure 14	25°C Full	1.95 V	-0.2	0.1	0.2 2	$\mu\text{A}$
COM OFF leakage current	$I_{COM(OFF)}$	$V_{COM} = 0.3\text{ V}$ , $V_{NO} = 1.65\text{ V}$ , or $V_{COM} = 1.65\text{ V}$ , $V_{NO} = 0.3\text{ V}$ , Switch OFF, See Figure 14	25°C Full	1.95 V	-0.1	0.05	0.1 0.2	$\mu\text{A}$
NO ON leakage current	$I_{NO(ON)}$	$V_{NO} = 0.3\text{ V}$ , $V_{COM} = \text{Open}$ , or $V_{NO} = 1.65\text{ V}$ , $V_{COM} = \text{Open}$ , Switch ON, See Figure 15	25°C Full	1.95 V	-0.2	0.1	0.2 2	$\mu\text{A}$
COM ON leakage current	$I_{COM(ON)}$	$V_{COM} = 0.3\text{ V}$ , $V_{NO} = \text{Open}$ , or $V_{COM} = 1.65\text{ V}$ , $V_{NO} = \text{Open}$ , Switch ON, See Figure 15	25°C Full	1.95 V	-0.1	0.05	0.1 0.2	$\mu\text{A}$
<b>Digital Control Input (IN)</b>								
Input logic high	$V_{IH}$		Full		$V_+ \times 0.65$		5.5	V
Input logic low	$V_{IL}$		Full		0		$V_+ \times 0.35$	V
Input leakage current	$I_{IH}, I_{IL}$	$V_I = 5.5\text{ V or }0$	25°C Full	1.95 V	-0.1	0.05	0.1 1	$\mu\text{A}$

(1) The algebraic convention is used in this data sheet; the most negative value is shown in the minimum column.

**Electrical Characteristics for 1.8-V Supply<sup>(1)</sup> (continued)**
 $V_+ = 1.65 \text{ V to } 1.95 \text{ V}$ ,  $T_A = -40^\circ\text{C to } 85^\circ\text{C}$  (unless otherwise noted)

PARAMETER	SYMBOL	TEST CONDITIONS		$T_A$	$V_+$	MIN	TYP	MAX	UNIT
<b>Dynamic</b>									
Turn-on time	$t_{ON}$	$V_{COM} = 1.3 \text{ V}$ , $R_L = 300 \Omega$ ,	$C_L = 35 \text{ pF}$ , See Figure 17	25°C	1.8 V	9.5	10	12	ns
				Full	1.65 V to 1.95 V	8.5		13	
Turn-off time	$t_{OFF}$	$V_{COM} = 1.3 \text{ V}$ , $R_L = 300 \Omega$ ,	$C_L = 35 \text{ pF}$ , See Figure 17	25°C	1.8 V	1.5	2	4	ns
				Full	1.65 V to 1.95 V	1.5		5.5	
Charge injection	$Q_C$	$V_{GEN} = 0$ , $C_L = 0.1 \text{ nF}$ ,	See Figure 20	25°C	1.8 V		1		pC
NO OFF capacitance	$C_{NO(OFF)}$	$V_{NO} = V_+$ or GND, Switch OFF,	See Figure 16	25°C	1.8 V		6.8		pF
COM OFF capacitance	$C_{COM(OFF)}$	$V_{COM} = V_+$ or GND, Switch OFF,	See Figure 16	25°C	1.8 V		6.8		pF
NO ON capacitance	$C_{NO(ON)}$	$V_{NO} = V_+$ or GND, Switch ON,	See Figure 16	25°C	1.8 V		14		pF
COM ON capacitance	$C_{COM(ON)}$	$V_{COM} = V_+$ or GND, Switch ON,	See Figure 16	25°C	1.8 V		14		pF
Digital input capacitance	$C_i$	$V_i = V_+$ or GND,	See Figure 16	25°C	1.8 V		2.2		pF
Bandwidth	BW	$R_L = 50 \Omega$ , Switch ON,	See Figure 18	25°C	1.8 V		400		MHz
OFF isolation	$O_{ISO}$	$R_L = 50 \Omega$ , $f = 10 \text{ MHz}$ ,	Switch OFF, See Figure 19	25°C	1.8 V		-68		dB
Total harmonic distortion	THD	$R_L = 600 \Omega$ , $C_L = 50 \text{ pF}$ ,	$f = 20 \text{ Hz to } 20 \text{ kHz}$ , See Figure 21	25°C	1.8 V		0.32		%
<b>Supply</b>									
Positive supply current	$I_+$	$V_i = V_+$ or GND,	Switch ON or OFF	25°C	1.95 V	0.05		1	$\mu\text{A}$
				Full			5		

TYPICAL PERFORMANCE

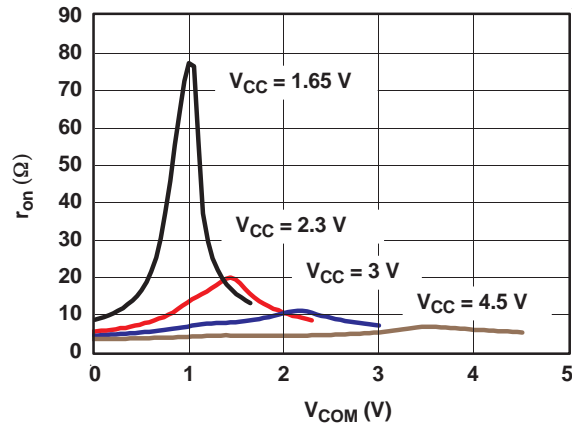


Figure 1.  $r_{on}$  vs  $V_{COM}$

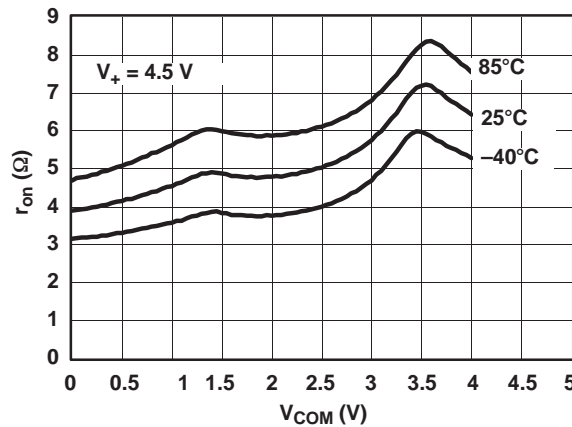


Figure 2.  $r_{on}$  vs  $V_{COM}$  ( $V_+ = 3$  V)

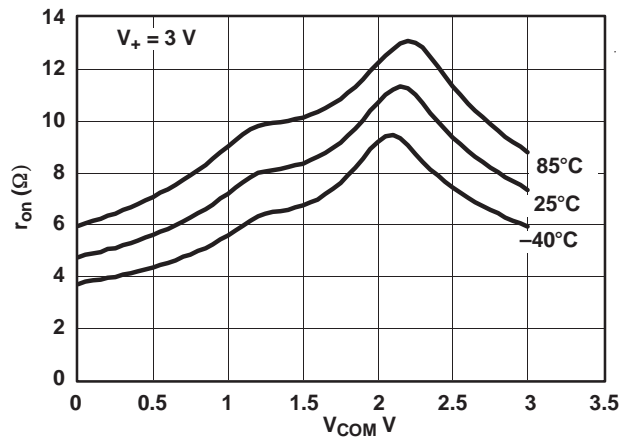


Figure 3.  $r_{on}$  vs  $V_{COM}$  ( $V_+ = 5$  V)

TYPICAL PERFORMANCE

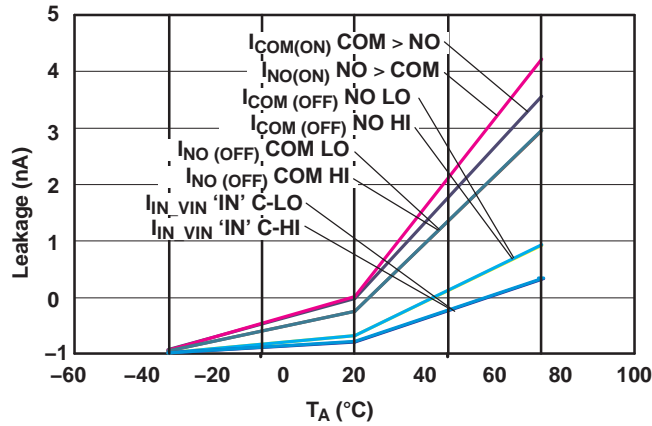


Figure 4. Leakage Current vs Temperature ( $V_+ = 5.5\text{ V}$ )

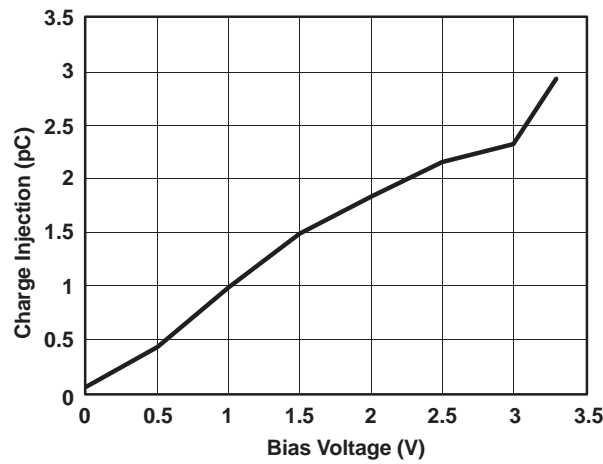


Figure 5. Charge Injection ( $Q_C$ ) vs Bias Voltage

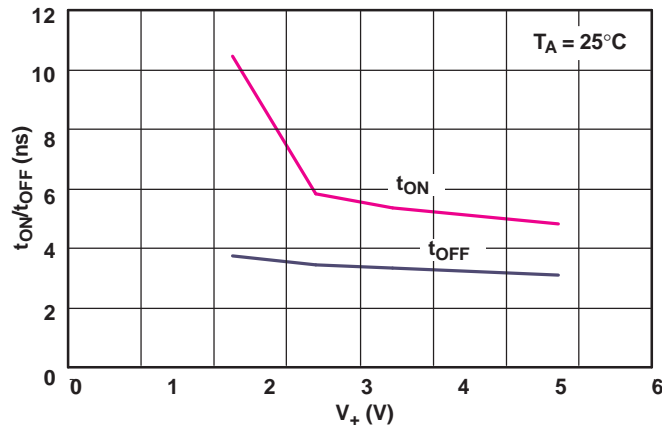


Figure 6.  $t_{ON}$  and  $t_{OFF}$  vs Supply Voltage

TYPICAL PERFORMANCE

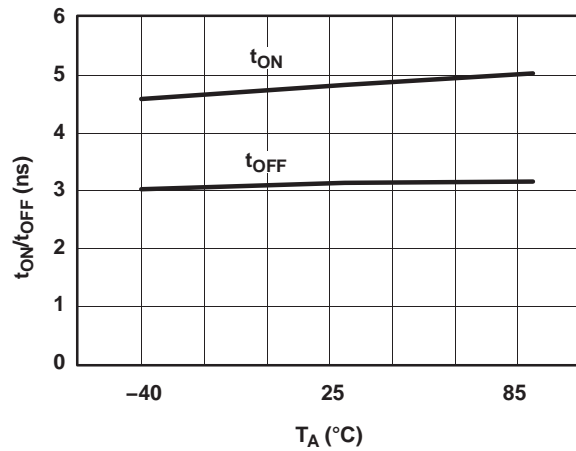


Figure 7.  $t_{ON}$  and  $t_{OFF}$  vs Temperature ( $V_+ = 5$  V)

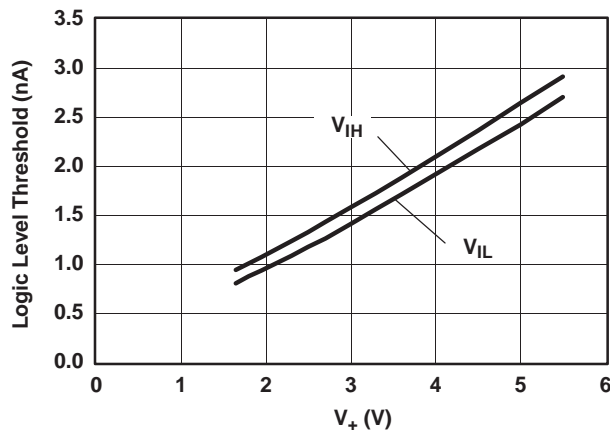


Figure 8. Logic-Level Threshold vs  $V_+$

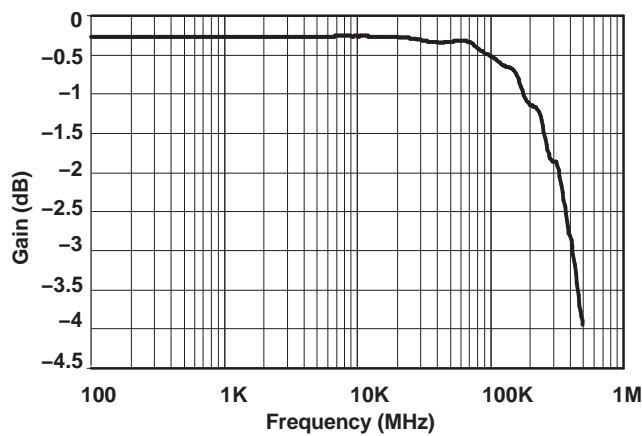


Figure 9. Bandwidth ( $V_+ = 5$  V)

TYPICAL PERFORMANCE

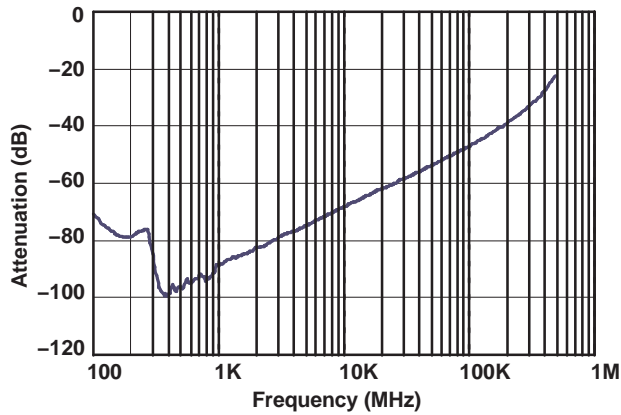


Figure 10. OFF Isolation ( $V_+ = 5\text{ V}$ )

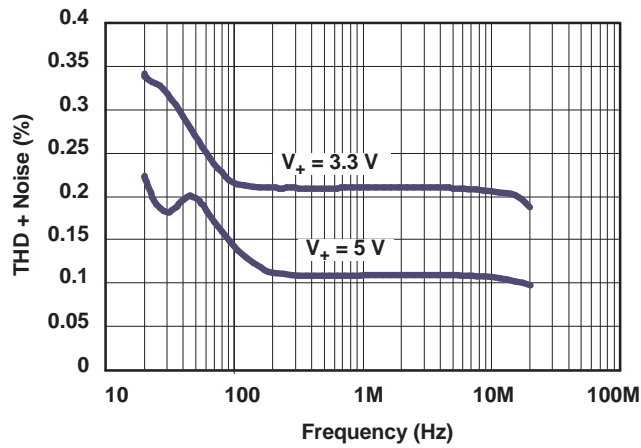


Figure 11. Total Harmonic Distortion vs Frequency

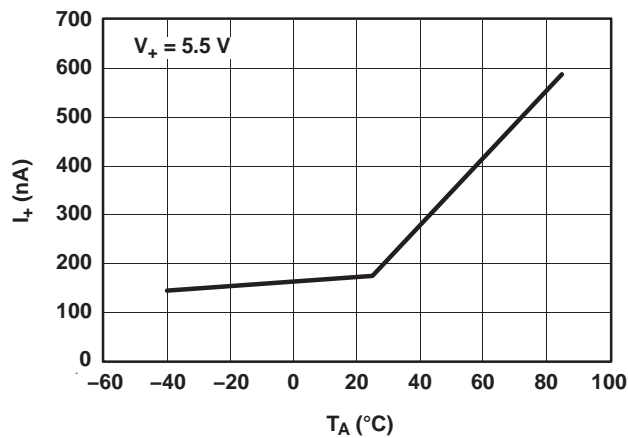


Figure 12. Power-Supply Current vs Temperature ( $V_+ = 5\text{ V}$ )

**Table 3. PIN DESCRIPTION**

PIN	NAME	DESCRIPTION
1	NO	Normally open
2	COM	Common
3	GND	Digital ground
4	IN	Digital control to connect COM to NO
5	V <sub>+</sub>	Power supply

**Table 4. PARAMETER DESCRIPTION**

SYMBOL	DESCRIPTION
V <sub>COM</sub>	Voltage at COM
V <sub>NO</sub>	Voltage at NO
r <sub>on</sub>	Resistance between COM and NO ports when the channel is ON
r <sub>on(flat)</sub>	Difference between the maximum and minimum value of r <sub>on</sub> in a channel over the specified range of conditions
I <sub>NO(OFF)</sub>	Leakage current measured at the NO port, with the corresponding channel (NO to COM) in the OFF state
I <sub>NO(ON)</sub>	Leakage current measured at the NO port, with the corresponding channel (NO to COM) in the ON state and the output (COM) open
I <sub>COM(OFF)</sub>	Leakage current measured at the COM port, with the corresponding channel (COM to NO) in the OFF state
I <sub>COM(ON)</sub>	Leakage current measured at the COM port, with the corresponding channel (COM to NO) in the ON state and the output (NO) open
V <sub>IH</sub>	Minimum input voltage for logic high for the control input (IN)
V <sub>IL</sub>	Maximum input voltage for logic low for the control input (IN)
V <sub>I</sub>	Voltage at the control input (IN)
I <sub>IH</sub> , I <sub>IL</sub>	Leakage current measured at the control input (IN)
t <sub>ON</sub>	Turn-on time for the switch. This parameter is measured under the specified range of conditions and by the propagation delay between the digital control (IN) signal and analog output (COM or NO) signal when the switch is turning ON.
t <sub>OFF</sub>	Turn-off time for the switch. This parameter is measured under the specified range of conditions and by the propagation delay between the digital control (IN) signal and analog output (COM or NO) signal when the switch is turning OFF.
Q <sub>C</sub>	Charge injection is a measurement of unwanted signal coupling from the control (IN) input to the analog (NO or COM) output. This is measured in coulomb (C) and measured by the total charge induced due to switching of the control input. Charge injection, $Q_C = C_L \times \Delta V_{COM}$ , C <sub>L</sub> is the load capacitance and $\Delta V_{COM}$ is the change in analog output voltage.
C <sub>NO(OFF)</sub>	Capacitance at the NO port when the corresponding channel (NO to COM) is OFF
C <sub>NO(ON)</sub>	Capacitance at the NO port when the corresponding channel (NO to COM) is ON
C <sub>COM(OFF)</sub>	Capacitance at the COM port when the corresponding channel (COM to NO) is OFF
C <sub>COM(ON)</sub>	Capacitance at the COM port when the corresponding channel (COM to NO) is ON
C <sub>I</sub>	Capacitance of IN
O <sub>ISO</sub>	OFF isolation of the switch is a measurement of OFF-state switch impedance. This is measured in dB in a specific frequency, with the corresponding channel (NO to COM) in the OFF state.
BW	Bandwidth of the switch. This is the frequency in which the gain of an ON channel is -3 dB below the DC gain.
THD	Total harmonic distortion is defined as the ratio of the root mean square (RMS) value of the second, third, and higher harmonics to the magnitude of fundamental harmonic.
I <sub>+</sub>	Static power-supply current with the control (IN) pin at V <sub>+</sub> or GND
$\Delta I_+$	This is the increase in I <sub>+</sub> for each control (IN) input that is at the specified voltage, rather than at V <sub>+</sub> or GND.

PARAMETER MEASUREMENT INFORMATION

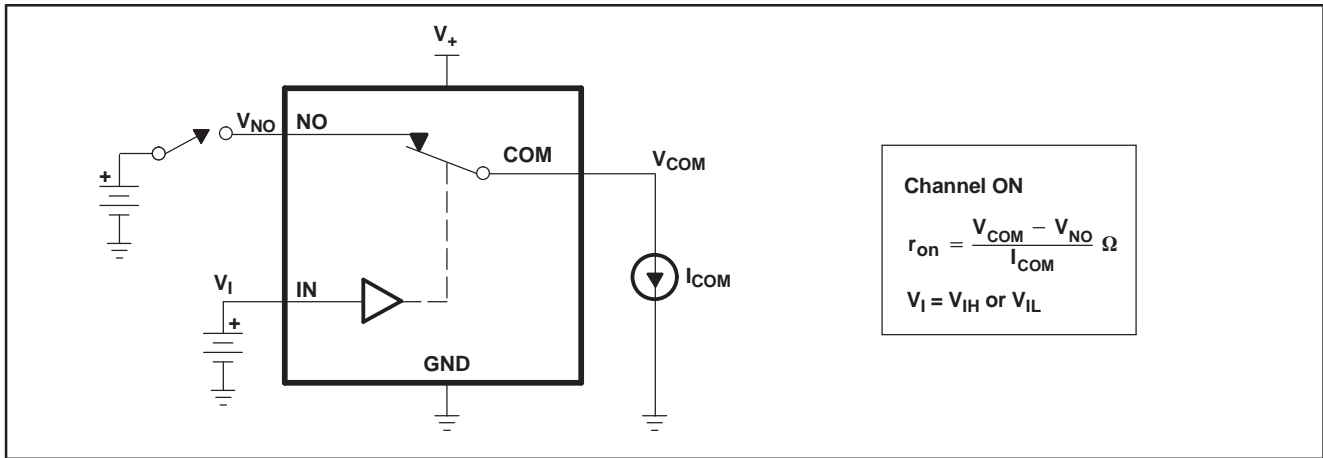


Figure 13. ON-State Resistance ( $r_{on}$ )

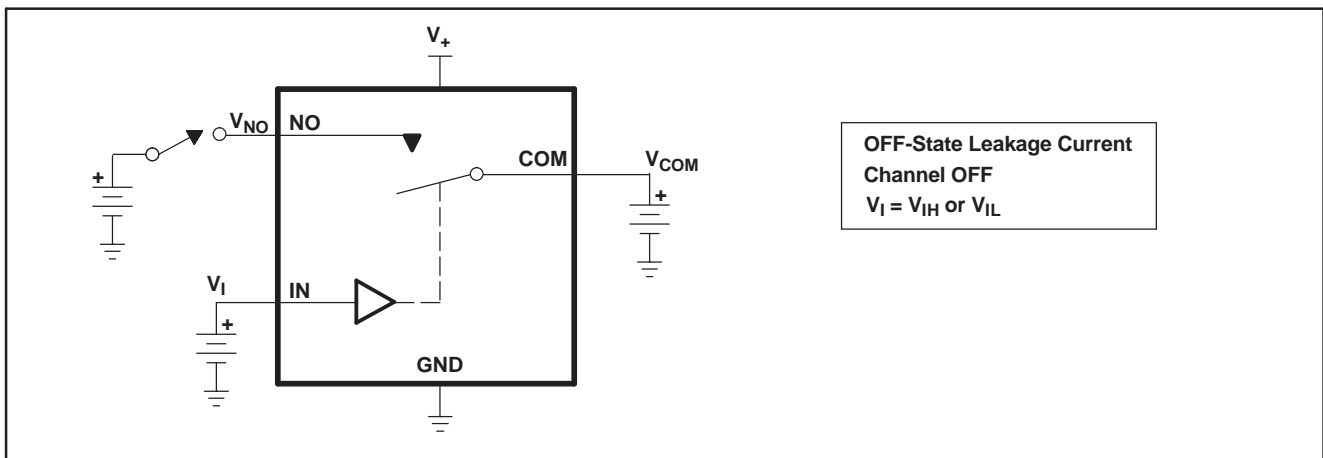


Figure 14. OFF-State Leakage Current ( $I_{COM(OFF)}$ ,  $I_{NO(OFF)}$ )

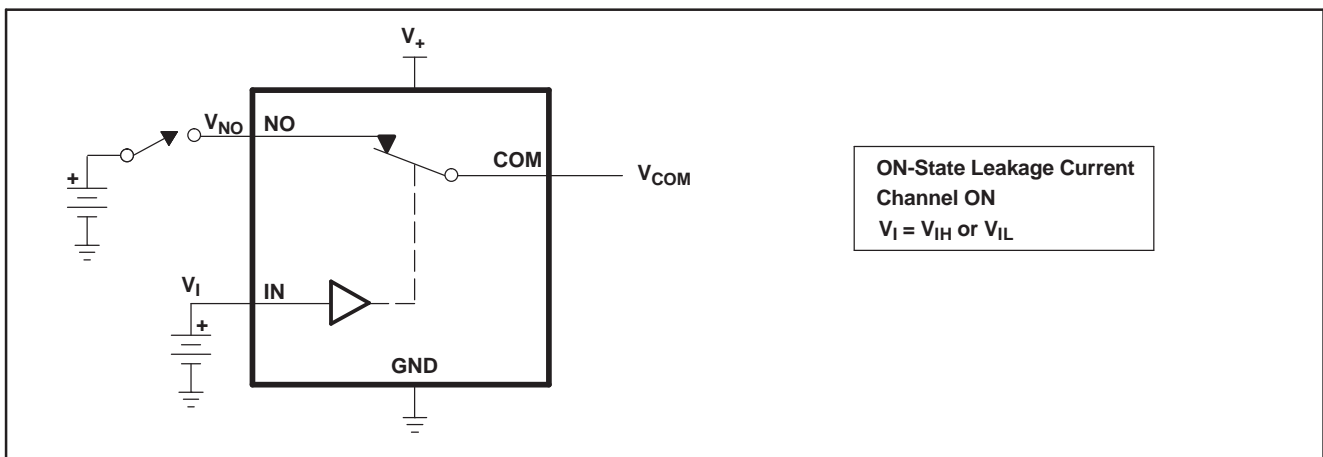


Figure 15. ON-State Leakage Current ( $I_{COM(ON)}$ ,  $I_{NO(ON)}$ )

PARAMETER MEASUREMENT INFORMATION (continued)

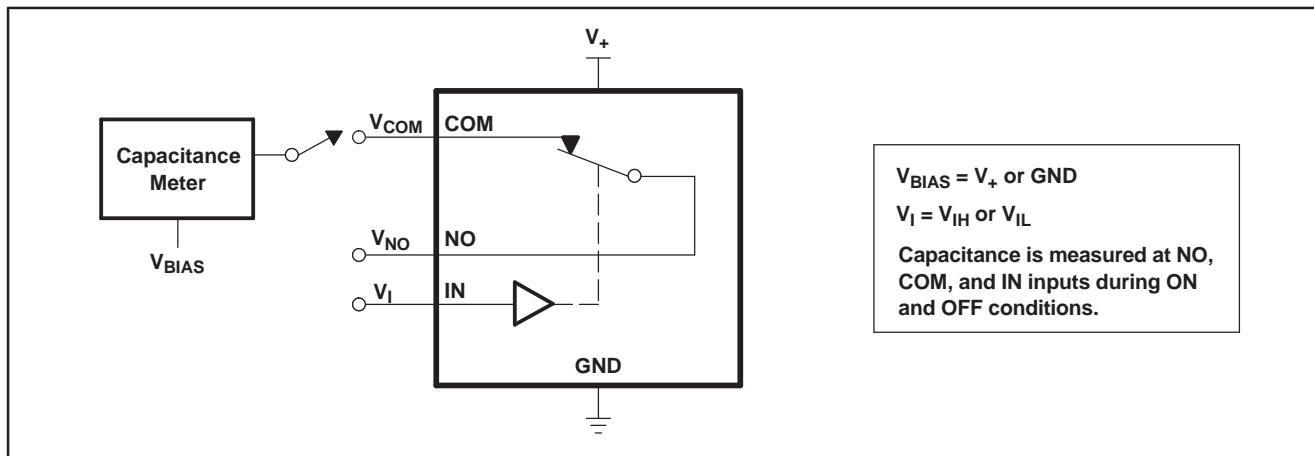
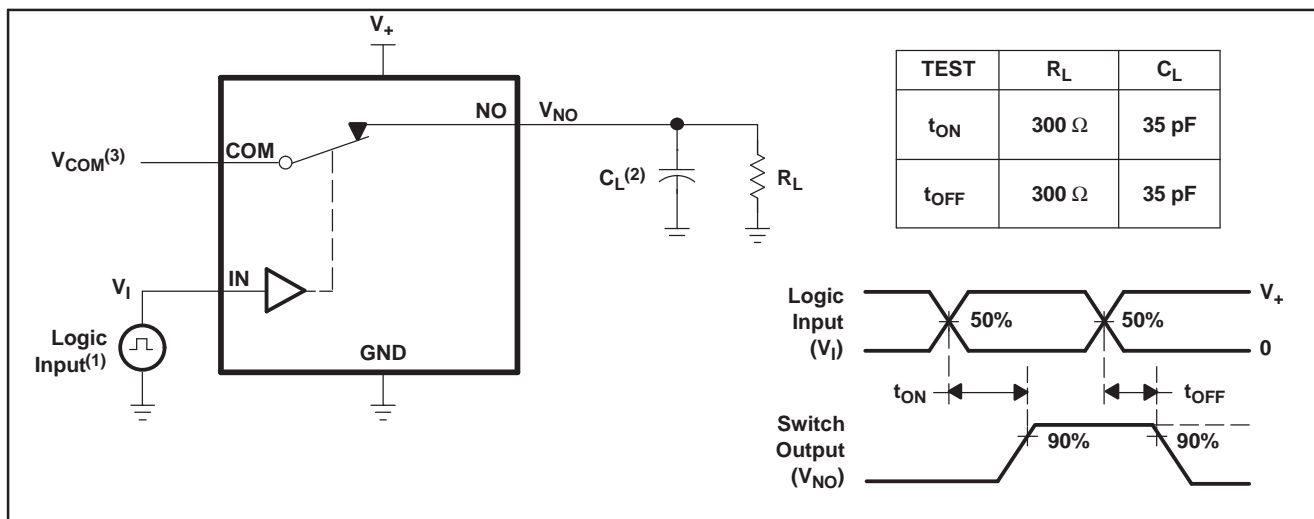


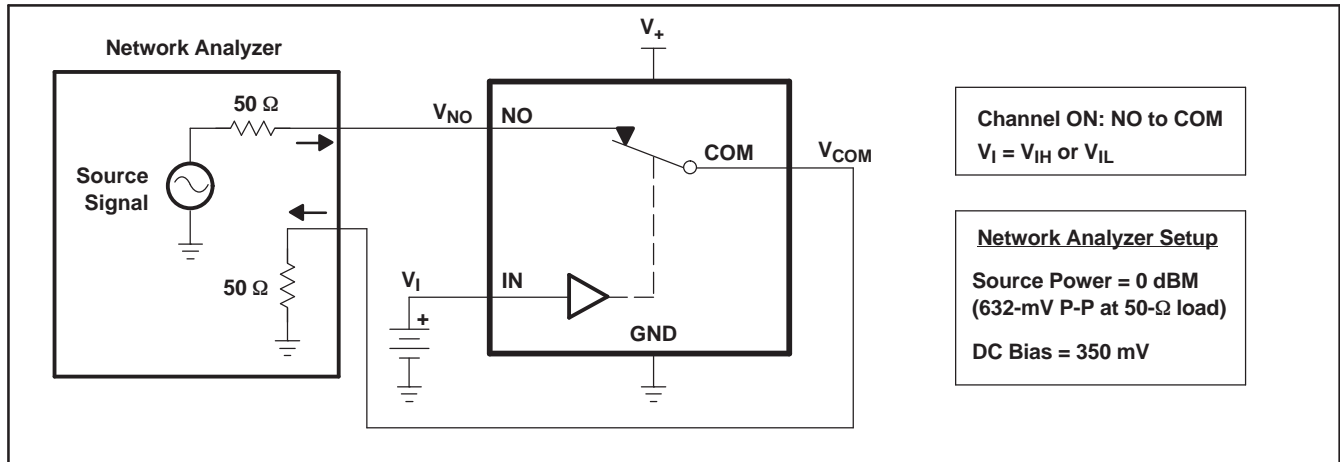
Figure 16. Capacitance ( $C_I$ ,  $C_{COM(OFF)}$ ,  $C_{COM(ON)}$ ,  $C_{NO(OFF)}$ ,  $C_{NO(ON)}$ )



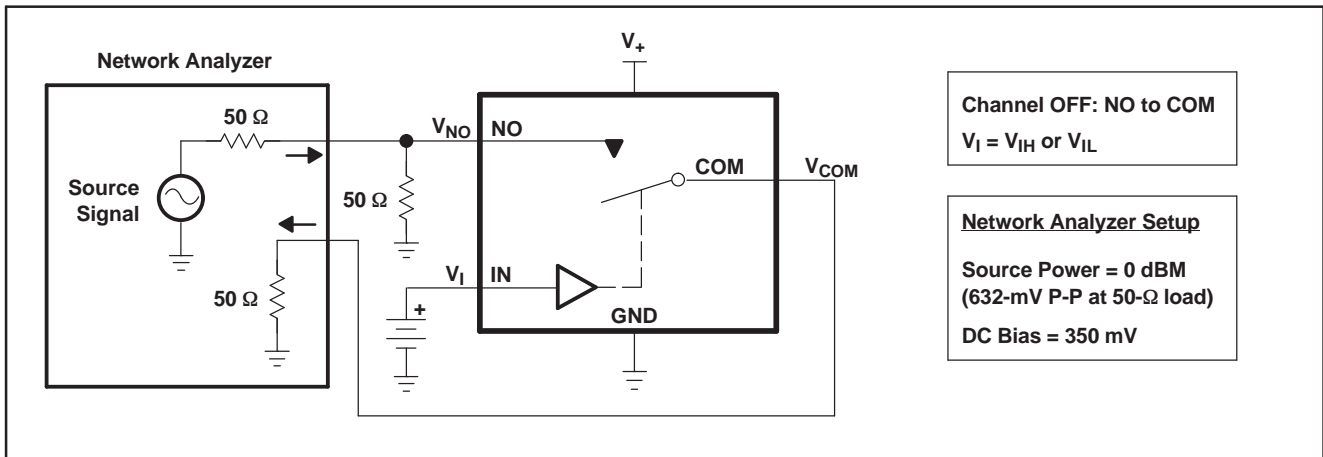
- (1) All input pulses are supplied by generators having the following characteristics: PRR  $\leq$  10 MHz,  $Z_O = 50 \Omega$ ,  $t_r < 5$  ns,  $t_f < 5$  ns.
- (2)  $C_L$  includes probe and jig capacitance.
- (3) See Electrical Characteristics for  $V_{COM}$ .

Figure 17. Turn-On ( $t_{ON}$ ) and Turn-Off Time ( $t_{OFF}$ )

**PARAMETER MEASUREMENT INFORMATION (continued)**

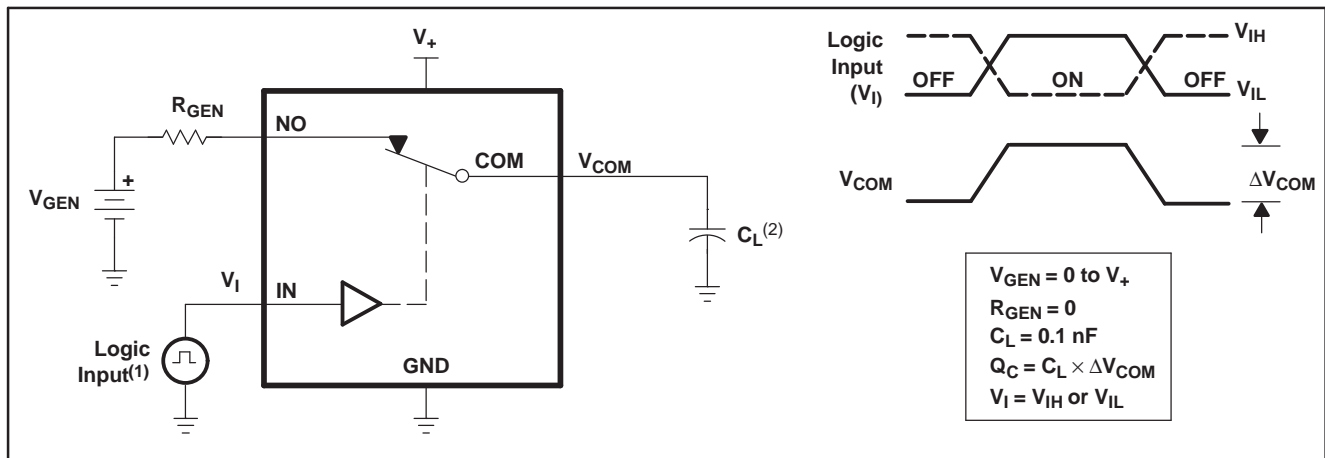


**Figure 18. Bandwidth (BW)**



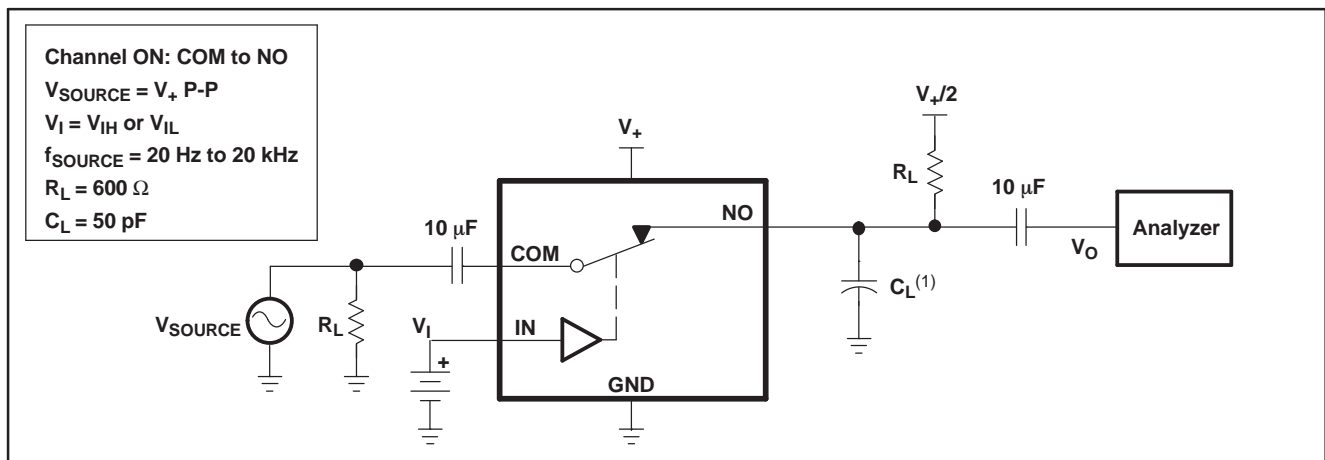
**Figure 19. OFF Isolation ( $O_{ISO}$ )**

PARAMETER MEASUREMENT INFORMATION (continued)



- (1) All input pulses are supplied by generators having the following characteristics: PRR ≤ 10 MHz, Z<sub>O</sub> = 50 Ω, t<sub>r</sub> < 5 ns, t<sub>f</sub> < 5 ns.
- (2) C<sub>L</sub> includes probe and jig capacitance.

Figure 20. Charge Injection (Q<sub>C</sub>)



- (1) C<sub>L</sub> includes probe and jig capacitance.

Figure 21. Total Harmonic Distortion (THD)

## REVISION HISTORY

Changes from Revision B (April 2006) to Revision C	Page
• Updated package options information. ....	<a href="#">2</a>

**PACKAGING INFORMATION**

Orderable Device	Status (1)	Package Type	Package Drawing	Pins	Package Qty	Eco Plan (2)	Lead/Ball Finish (6)	MSL Peak Temp (3)	Op Temp (°C)	Device Marking (4/5)	Samples
TS5A1066DBVR	ACTIVE	SOT-23	DBV	5	3000	Green (RoHS & no Sb/Br)	CU NIPDAU   CU SN	Level-1-260C-UNLIM	-40 to 85	(JADF, JADJ, JADR)	<a href="#">Samples</a>
TS5A1066DBVRG4	ACTIVE	SOT-23	DBV	5	3000	Green (RoHS & no Sb/Br)	CU NIPDAU	Level-1-260C-UNLIM	-40 to 85	JADF	<a href="#">Samples</a>
TS5A1066DCKR	ACTIVE	SC70	DCK	5	3000	Green (RoHS & no Sb/Br)	CU NIPDAU   CU SN	Level-1-260C-UNLIM	-40 to 85	(JD5, JDF, JDJ, JDR)	<a href="#">Samples</a>
TS5A1066DCKRG4	ACTIVE	SC70	DCK	5	3000	Green (RoHS & no Sb/Br)	CU NIPDAU	Level-1-260C-UNLIM	-40 to 85	(JD5, JDF, JDJ, JDR)	<a href="#">Samples</a>
TS5A1066YZPR	ACTIVE	DSBGA	YZP	5	3000	Green (RoHS & no Sb/Br)	SNAGCU	Level-1-260C-UNLIM	-40 to 85	(JD7, JDN)	<a href="#">Samples</a>

(1) The marketing status values are defined as follows:

**ACTIVE:** Product device recommended for new designs.

**LIFEBUY:** TI has announced that the device will be discontinued, and a lifetime-buy period is in effect.

**NRND:** Not recommended for new designs. Device is in production to support existing customers, but TI does not recommend using this part in a new design.

**PREVIEW:** Device has been announced but is not in production. Samples may or may not be available.

**OBSOLETE:** TI has discontinued the production of the device.

(2) **RoHS:** TI defines "RoHS" to mean semiconductor products that are compliant with the current EU RoHS requirements for all 10 RoHS substances, including the requirement that RoHS substance do not exceed 0.1% by weight in homogeneous materials. Where designed to be soldered at high temperatures, "RoHS" products are suitable for use in specified lead-free processes. TI may reference these types of products as "Pb-Free".

**RoHS Exempt:** TI defines "RoHS Exempt" to mean products that contain lead but are compliant with EU RoHS pursuant to a specific EU RoHS exemption.

**Green:** TI defines "Green" to mean the content of Chlorine (Cl) and Bromine (Br) based flame retardants meet JS709B low halogen requirements of <=1000ppm threshold. Antimony trioxide based flame retardants must also meet the <=1000ppm threshold requirement.

(3) MSL, Peak Temp. - The Moisture Sensitivity Level rating according to the JEDEC industry standard classifications, and peak solder temperature.

(4) There may be additional marking, which relates to the logo, the lot trace code information, or the environmental category on the device.

(5) Multiple Device Markings will be inside parentheses. Only one Device Marking contained in parentheses and separated by a "-" will appear on a device. If a line is indented then it is a continuation of the previous line and the two combined represent the entire Device Marking for that device.

(6) Lead/Ball Finish - Orderable Devices may have multiple material finish options. Finish options are separated by a vertical ruled line. Lead/Ball Finish values may wrap to two lines if the finish value exceeds the maximum column width.

**Important Information and Disclaimer:**The information provided on this page represents TI's knowledge and belief as of the date that it is provided. TI bases its knowledge and belief on information provided by third parties, and makes no representation or warranty as to the accuracy of such information. Efforts are underway to better integrate information from third parties. TI has taken and continues to take reasonable steps to provide representative and accurate information but may not have conducted destructive testing or chemical analysis on incoming materials and chemicals. TI and TI suppliers consider certain information to be proprietary, and thus CAS numbers and other limited information may not be available for release.

In no event shall TI's liability arising out of such information exceed the total purchase price of the TI part(s) at issue in this document sold by TI to Customer on an annual basis.

**TAPE AND REEL INFORMATION**

**QUADRANT ASSIGNMENTS FOR PIN 1 ORIENTATION IN TAPE**


\*All dimensions are nominal

Device	Package Type	Package Drawing	Pins	SPQ	Reel Diameter (mm)	Reel Width W1 (mm)	A0 (mm)	B0 (mm)	K0 (mm)	P1 (mm)	W (mm)	Pin1 Quadrant
TS5A1066DBVR	SOT-23	DBV	5	3000	178.0	9.0	3.23	3.17	1.37	4.0	8.0	Q3
TS5A1066DBVR	SOT-23	DBV	5	3000	180.0	8.4	3.23	3.17	1.37	4.0	8.0	Q3
TS5A1066DBVRG4	SOT-23	DBV	5	3000	178.0	9.0	3.23	3.17	1.37	4.0	8.0	Q3
TS5A1066DCKR	SC70	DCK	5	3000	178.0	9.0	2.4	2.5	1.2	4.0	8.0	Q3
TS5A1066DCKR	SC70	DCK	5	3000	178.0	9.2	2.4	2.4	1.22	4.0	8.0	Q3
TS5A1066DCKR	SC70	DCK	5	3000	178.0	9.0	2.4	2.5	1.2	4.0	8.0	Q3
TS5A1066YZPR	DSBGA	YZP	5	3000	178.0	9.2	1.02	1.52	0.63	4.0	8.0	Q1

**TAPE AND REEL BOX DIMENSIONS**


\*All dimensions are nominal

Device	Package Type	Package Drawing	Pins	SPQ	Length (mm)	Width (mm)	Height (mm)
TS5A1066DBVR	SOT-23	DBV	5	3000	180.0	180.0	18.0
TS5A1066DBVR	SOT-23	DBV	5	3000	202.0	201.0	28.0
TS5A1066DBVRG4	SOT-23	DBV	5	3000	180.0	180.0	18.0
TS5A1066DCKR	SC70	DCK	5	3000	180.0	180.0	18.0
TS5A1066DCKR	SC70	DCK	5	3000	180.0	180.0	18.0
TS5A1066DCKR	SC70	DCK	5	3000	180.0	180.0	18.0
TS5A1066YZPR	DSBGA	YZP	5	3000	220.0	220.0	35.0



# EXAMPLE BOARD LAYOUT

YZP0005

DSBGA - 0.5 mm max height

DIE SIZE BALL GRID ARRAY



LAND PATTERN EXAMPLE  
SCALE:40X



SOLDER MASK DETAILS  
NOT TO SCALE

4219492/A 05/2017

NOTES: (continued)

3. Final dimensions may vary due to manufacturing tolerance considerations and also routing constraints. For more information, see Texas Instruments literature number SNVA009 ([www.ti.com/lit/snva009](http://www.ti.com/lit/snva009)).

# EXAMPLE STENCIL DESIGN

YZP0005

DSBGA - 0.5 mm max height

DIE SIZE BALL GRID ARRAY



SOLDER PASTE EXAMPLE  
BASED ON 0.1 mm THICK STENCIL  
SCALE:40X

4219492/A 05/2017

NOTES: (continued)

4. Laser cutting apertures with trapezoidal walls and rounded corners may offer better paste release.



# EXAMPLE BOARD LAYOUT

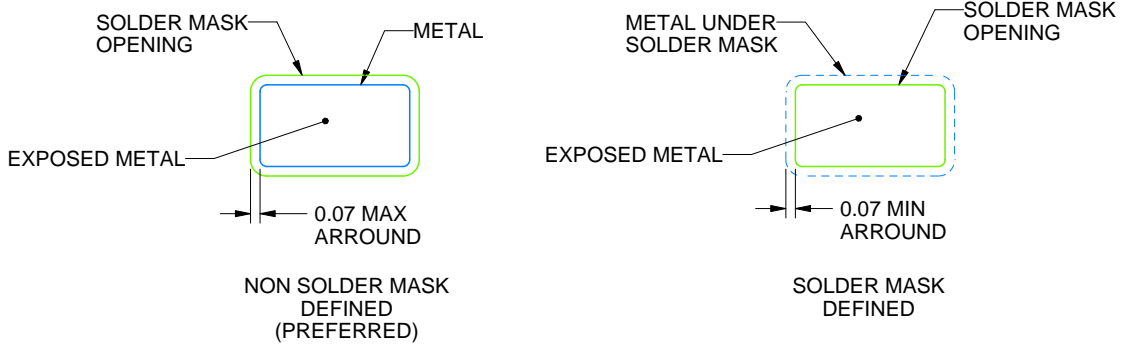
DBV0005A

SOT-23 - 1.45 mm max height

SMALL OUTLINE TRANSISTOR



LAND PATTERN EXAMPLE  
EXPOSED METAL SHOWN  
SCALE:15X



SOLDER MASK DETAILS

4214839/D 11/2018

NOTES: (continued)

- 5. Publication IPC-7351 may have alternate designs.
- 6. Solder mask tolerances between and around signal pads can vary based on board fabrication site.

# EXAMPLE STENCIL DESIGN

DBV0005A

SOT-23 - 1.45 mm max height

SMALL OUTLINE TRANSISTOR



SOLDER PASTE EXAMPLE  
BASED ON 0.125 mm THICK STENCIL  
SCALE:15X

4214839/D 11/2018

NOTES: (continued)

7. Laser cutting apertures with trapezoidal walls and rounded corners may offer better paste release. IPC-7525 may have alternate design recommendations.
8. Board assembly site may have different recommendations for stencil design.

DCK (R-PDSO-G5)

PLASTIC SMALL-OUTLINE PACKAGE



- NOTES:
- A. All linear dimensions are in millimeters.
  - B. This drawing is subject to change without notice.
  - C. Body dimensions do not include mold flash or protrusion. Mold flash and protrusion shall not exceed 0.15 per side.
  - D. Falls within JEDEC MO-203 variation AA.

DCK (R-PDSO-G5)

PLASTIC SMALL OUTLINE



- NOTES:
- All linear dimensions are in millimeters.
  - This drawing is subject to change without notice.
  - Customers should place a note on the circuit board fabrication drawing not to alter the center solder mask defined pad.
  - Publication IPC-7351 is recommended for alternate designs.
  - Laser cutting apertures with trapezoidal walls and also rounding corners will offer better paste release. Customers should contact their board assembly site for stencil design recommendations. Example stencil design based on a 50% volumetric metal load solder paste. Refer to IPC-7525 for other stencil recommendations.

## IMPORTANT NOTICE AND DISCLAIMER

TI PROVIDES TECHNICAL AND RELIABILITY DATA (INCLUDING DATASHEETS), DESIGN RESOURCES (INCLUDING REFERENCE DESIGNS), APPLICATION OR OTHER DESIGN ADVICE, WEB TOOLS, SAFETY INFORMATION, AND OTHER RESOURCES "AS IS" AND WITH ALL FAULTS, AND DISCLAIMS ALL WARRANTIES, EXPRESS AND IMPLIED, INCLUDING WITHOUT LIMITATION ANY IMPLIED WARRANTIES OF MERCHANTABILITY, FITNESS FOR A PARTICULAR PURPOSE OR NON-INFRINGEMENT OF THIRD PARTY INTELLECTUAL PROPERTY RIGHTS.

These resources are intended for skilled developers designing with TI products. You are solely responsible for (1) selecting the appropriate TI products for your application, (2) designing, validating and testing your application, and (3) ensuring your application meets applicable standards, and any other safety, security, or other requirements. These resources are subject to change without notice. TI grants you permission to use these resources only for development of an application that uses the TI products described in the resource. Other reproduction and display of these resources is prohibited. No license is granted to any other TI intellectual property right or to any third party intellectual property right. TI disclaims responsibility for, and you will fully indemnify TI and its representatives against, any claims, damages, costs, losses, and liabilities arising out of your use of these resources.

TI's products are provided subject to TI's Terms of Sale ([www.ti.com/legal/termsofsale.html](http://www.ti.com/legal/termsofsale.html)) or other applicable terms available either on [ti.com](http://ti.com) or provided in conjunction with such TI products. TI's provision of these resources does not expand or otherwise alter TI's applicable warranties or warranty disclaimers for TI products.

Mailing Address: Texas Instruments, Post Office Box 655303, Dallas, Texas 75265  
Copyright © 2019, Texas Instruments Incorporated

## Looking for pricing, stock, or lifecycle information?

Click below to explore more details on WIN SOURCE:

 [View TS5A1066DBVR on WIN SOURCE](#)

 [Texas Instruments](#) Information

## Optimize Your Supply Chain with WIN SOURCE Solutions

-  Global Sourcing Solution
-  Obsolete Management
-  Cost Control Management
-  Shortage Management
-  Alternative Solution
-  Excess Inventory Management