

TS3USB31E High-Speed USB 2.0 (480-Mbps) 1-Port Switch with Single Enable and ESD Protection

1 Features

- V_{CC} Operation 2.25 V to 4.3 V
- 1.8-V Compatible Control-Pin Inputs
- I_{OFF} Supports Partial Power-Down Mode Operation
- $r_{on} = 10 \Omega$ Maximum
- $\Delta r_{on} < 0.35 \Omega$ Typical
- $C_{io(ON)} = 6$ pF Typical
- Low Power Consumption (1 μ A Maximum)
- ESD Performance Tested Per JESD 22
 - 8000-V Human-Body Model (A114-B, Class II)
 - 1000-V Charged-Device Model (C101)
 - 250-V Machine Model (A115-A)
- ESD Performance COM Port to GND
 - 15000-V Human-Body Model (A114-B, Class II)
- Wide -3 -dB Bandwidth = 1100 MHz Typical
- Packaged in 8-Pin TQFN (1.5 mm \times 1.5 mm)

2 Applications

- Routes Signals for USB 1.0, 1.1, and 2.0

3 Description

The TS3USB31E is a high-bandwidth switch specially designed for the switching of high-speed USB 2.0 signals in handset and consumer applications, such as cell phones, digital cameras, and notebooks with hubs or controllers with limited USB I/Os. The wide bandwidth (1100 MHz) of this switch allows signals to pass with minimum edge and phase distortion. The switch is bidirectional and offers little or no attenuation of the high-speed signals at the outputs. It is designed for low bit-to-bit skew and high channel-to-channel noise isolation, and is compatible with various standards, such as high-speed USB 2.0 (480 Mbps).

Device Information⁽¹⁾

PART NUMBER	PACKAGE	BODY SIZE (NOM)
TS3USB31E	UQFN (8)	1.50 mm \times 1.50 mm

(1) For all available packages, see the orderable addendum at the end of the data sheet.

Functional Block Diagram

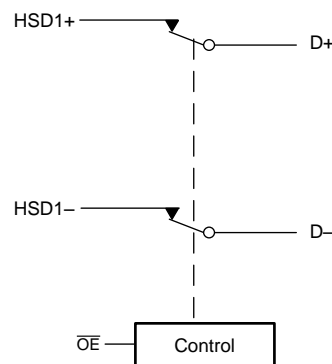

Copyright © 2016, Texas Instruments Incorporated



Table of Contents

1 Features	1	9.3 Feature Description.....	12
2 Applications	1	9.4 Device Functional Modes.....	12
3 Description	1	10 Application and Implementation	13
4 Revision History	2	10.1 Application Information.....	13
5 Pin Configuration and Functions	3	10.2 Typical Application	13
6 Specifications	4	11 Power Supply Recommendations	15
6.1 Absolute Maximum Ratings	4	12 Layout	15
6.2 ESD Ratings.....	4	12.1 Layout Guidelines	15
6.3 Recommended Operating Conditions.....	4	12.2 Layout Example	16
6.4 Thermal Information	5	13 Device and Documentation Support	17
6.5 Electrical Characteristics.....	5	13.1 Documentation Support	17
6.6 Dynamic Electrical Characteristics.....	5	13.2 Receiving Notification of Documentation Updates	17
6.7 Switching Characteristics	6	13.3 Community Resource.....	17
7 Application Information	7	13.4 Trademarks	17
8 Parameter Measurement Information	8	13.5 Electrostatic Discharge Caution.....	17
9 Detailed Description	12	13.6 Glossary	17
9.1 Overview	12	14 Mechanical, Packaging, and Orderable	
9.2 Functional Block Diagram	12	Information	17

4 Revision History

NOTE: Page numbers for previous revisions may differ from page numbers in the current version.

Changes from Original (Oct 2009) to Revision A	Page
<ul style="list-style-type: none"> Added <i>ESD Ratings</i> table, <i>Feature Description</i> section, <i>Device Functional Modes</i>, <i>Application and Implementation</i> section, <i>Power Supply Recommendations</i> section, <i>Layout</i> section, <i>Device and Documentation Support</i> section, and <i>Mechanical, Packaging, and Orderable Information</i> section 	1

5 Pin Configuration and Functions

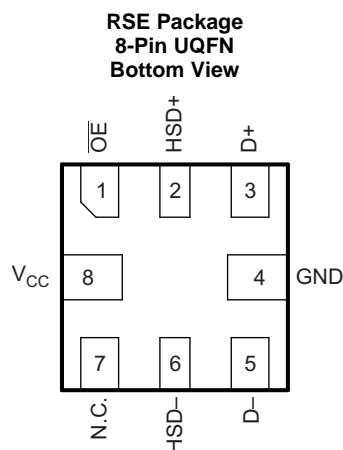
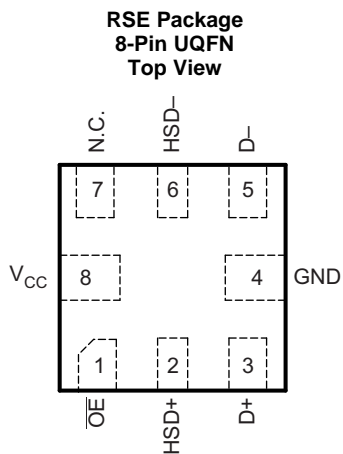

N.C. – No internal connection

Pin Functions

PIN		I/O	DESCRIPTION
NAME	NO.		
\overline{OE}	1	I	Bus-switch enable, To isolate the D_{\pm} pins from the HSD_{\pm} pins set \overline{OE} pin to valid high logic level, To connect D_{\pm} pins to HSD_{\pm} pins set \overline{OE} pin to valid low logic level
D+	3	I/O	Data ports
D-	5	I/O	Data ports
HSD+	2	I/O	Data ports
HSD-	6	I/O	Data ports
N.C.	7	—	No connect, This pin must be left floating or connect to ground
GND	4	—	Ground
V _{CC}	8	I/O	Supply voltage

6 Specifications

6.1 Absolute Maximum Ratings

over operating free-air temperature range (unless otherwise noted)⁽¹⁾

		MIN	MAX	UNIT
V _{CC}	Supply voltage	-0.5	7	V
V _{IN}	Control input voltage ⁽²⁾⁽³⁾	-0.5	7	V
V _{I/O}	Switch I/O voltage ⁽²⁾⁽³⁾⁽⁴⁾	HSD+, HSD-	V _{CC} + 0.3	V
		D+, D- when V _{CC} > 0	V _{CC} + 0.3	
		D+, D- when V _{CC} = 0	5.25	
I _{IK}	Control input clamp current	V _{IN} < 0	-50	mA
I _{I/O} K	I/O port clamp current	V _{I/O} < 0	-50	mA
I _{I/O}	ON-state switch current ⁽⁵⁾		±64	mA
	Continuous current through V _{CC} or GND		±100	mA
T _{stg}	Storage temperature	-65	150	°C

- (1) Stresses beyond those listed under *Absolute Maximum Ratings* may cause permanent damage to the device. These are stress ratings only, which do not imply functional operation of the device at these or any other conditions beyond those indicated under *Recommended Operating Conditions*. Exposure to absolute-maximum-rated conditions for extended periods may affect device reliability.
- (2) All voltages are with respect to ground, unless otherwise specified.
- (3) The input and output voltage ratings may be exceeded if the input and output clamp-current ratings are observed.
- (4) V_I and V_O are used to denote specific conditions for V_{I/O}.
- (5) I_I and I_O are used to denote specific conditions for I_{I/O}.

6.2 ESD Ratings

		VALUE	UNIT
V _(ESD)	Electrostatic discharge	Human-body model (HBM), per ANSI/ESDA/JEDEC JS-001 ⁽¹⁾	±8000
		Charged-device model (CDM), per JEDEC specification JESD22-C101 ⁽²⁾	±1000

- (1) JEDEC document JEP155 states that 500-V HBM allows safe manufacturing with a standard ESD control process.
- (2) JEDEC document JEP157 states that 250-V CDM allows safe manufacturing with a standard ESD control process.

6.3 Recommended Operating Conditions

over operating free-air temperature range (unless otherwise noted)⁽¹⁾

		MIN	MAX	UNIT
V _{CC}	Supply voltage	2.25	4.3	V
V _{IH}	High-level control input voltage	V _{CC} = 2.3 V to 2.7 V	0.9	V
		V _{CC} = 3 V to 3.6 V	1.3	
		V _{CC} = 4.3 V	1.7	
V _{IL}	Low-level control input voltage	V _{CC} = 2.3 V to 2.7 V	0.4	V
		V _{CC} = 3 V to 3.6 V	0.5	
		V _{CC} = 4.3 V	0.7	
V _{I/O}	Data input-output voltage	0	V _{CC}	V
T _A	Operating free-air temperature	-40	85	°C

- (1) All unused control inputs of the device must be held at V_{CC} or GND to ensure proper device operation. Refer to the TI application report, [Implications of Slow or Floating CMOS Inputs](#).

6.4 Thermal Information

THERMAL METRIC ⁽¹⁾		TS3USB31	UNIT
		RSE (UQFN)	
		8 PINS	
R _{θJA}	Junction-to-ambient thermal resistance	127.1	°C/W
R _{θJC(top)}	Junction-to-case (top) thermal resistance	70.4	°C/W
R _{θJB}	Junction-to-board thermal resistance	35	°C/W
ψ _{JT}	Junction-to-top characterization parameter	2.9	°C/W
ψ _{JB}	Junction-to-board characterization parameter	34.9	°C/W

(1) For more information about traditional and new thermal metrics, see the [Semiconductor and IC Package Thermal Metrics](#) application report.

6.5 Electrical Characteristics

over operating free-air temperature range (unless otherwise noted)⁽¹⁾

PARAMETER	TEST CONDITIONS	MIN	TYP ⁽²⁾	MAX	UNIT
V _{IK}	Input Clamp Voltage V _{CC} = 3 V, I _I = -18 mA			-1.2	V
I _{IN}	Control inputs V _{CC} = 4.3 V or 0 V, V _{IN} = 0 to 4.3 V			±1	μA
I _{OZ} ⁽³⁾	V _{CC} = 4.3 V, V _O = 0 to 3.6 V, V _I = 0, switch OFF			±1	μA
I _{OFF}	D+ and D- V _{CC} = 0 V, V _O = 0 V to 4.3 V, V _I = 0, V _{IN} = V _{CC} or GND			±2	μA
I _{CC}	V _{CC} = 4.3 V, I _{I/O} = 0, switch ON or OFF			1	μA
ΔI _{CC} ⁽⁴⁾	Control inputs V _{CC} = 4.3 V, V _{IN} = 2.6 V			10	μA
C _{in}	Control inputs V _{CC} = 0 V, V _{IN} = V _{CC} or GND		1		pF
C _{io(OFF)}	Off-state input-output capacitance V _{CC} = 2.5 V, V _{I/O} = 2.5 V or 0, switch OFF		2		pF
	V _{CC} = 3.3 V, V _{I/O} = 3.3 V or 0, switch OFF		2		
C _{io(ON)}	On-state input-output capacitance V _{CC} = 2.5 V, V _{I/O} = 2.5 V or 0, switch ON		6		pF
	V _{CC} = 3.3 V, V _{I/O} = 3.3 V or 0, switch ON		6		
r _{on} ⁽⁵⁾	On-state resistance V _{CC} = 2.5 V, V _I = 0.4 V, I _O = -8 mA		7.5	9	Ω
	V _{CC} = 3 V, V _I = 0.4 V, I _O = -8 mA		6.5	10	
Δr _{on}	Channel match V _{CC} = 2.5 V, V _I = 0.4 V, I _O = -8 mA		0.4		Ω
	V _{CC} = 3 V, V _I = 0.4 V, I _O = -8 mA		0.35		
r _{on(flat)}	On-state resistance flatness V _{CC} = 2.5 V, V _I = 0 V or 1 V, I _O = -8 mA		0.07		Ω
	V _{CC} = 3 V, V _I = 0 V or 1 V, I _O = -8 mA		2		

(1) V_{IN} and I_{IN} refer to control inputs. V_I, V_O, I_I, and I_O refer to data pins.

(2) All typical values are at V_{CC} = 3.3 V (unless otherwise noted), T_A = 25°C.

(3) For I/O ports, the parameter I_{OZ} includes the input leakage current.

(4) This is the increase in supply current for each input that is at the specified TTL voltage level, rather than V_{CC} or GND.

(5) Measured by the voltage drop between the A and B terminals at the indicated current through the switch. ON-state resistance is determined by the lower of the voltages of the two (A or B) terminals.

6.6 Dynamic Electrical Characteristics

over operating range, T_A = -40°C to +85°C, GND = 0 V

PARAMETER	TEST CONDITIONS	TYP ⁽¹⁾	UNIT
V_{CC} = 2.5 V ± 10%			
X _{TALK}	Crosstalk R _L = 50 Ω, f = 240 MHz, See Figure 6	-53	dB
O _{IRR}	OFF isolation R _L = 50 Ω, f = 240 MHz, See Figure 5	-30	dB
BW	Bandwidth (-3 dB) R _L = 50 Ω, C _L = 5 pF, See Figure 7	1100	MHz
V_{CC} = 3.3 V ± 10%			
X _{TALK}	Crosstalk R _L = 50 Ω, f = 240 MHz, See Figure 6	-53	dB

(1) For Max or Min conditions, use the appropriate value specified under [Electrical Characteristics](#) for the applicable device type.

Dynamic Electrical Characteristics (continued)

over operating range, $T_A = -40^\circ\text{C}$ to $+85^\circ\text{C}$, $\text{GND} = 0\text{ V}$

PARAMETER		TEST CONDITIONS	TYP ⁽¹⁾	UNIT
O_{IRR}	OFF isolation	$R_L = 50\ \Omega$, $f = 240\ \text{MHz}$, See Figure 5	-30	dB
BW	Bandwidth (-3 dB)	$R_L = 50\ \Omega$, $C_L = 5\ \text{pF}$, See Figure 7	1100	MHz

6.7 Switching Characteristics

over operating range, $T_A = -40^\circ\text{C}$ to 85°C , $\text{GND} = 0\text{ V}$

PARAMETER		TEST CONDITIONS	MIN	TYP ⁽¹⁾	MAX	UNIT
$V_{\text{CC}} = 2.5\ \text{V} \pm 10\%$						
t_{pd}	Propagation delay ⁽²⁾⁽³⁾	$R_L = 50\ \Omega$, $C_L = 5\ \text{pF}$, See Figure 8		0.25		ns
t_{ON}	Line enable time, $\overline{\text{OE}}$ to D, nD	$R_L = 50\ \Omega$, $C_L = 5\ \text{pF}$, See Figure 4			30	ns
t_{OFF}	Line disable time, $\overline{\text{OE}}$ to D, nD	$R_L = 50\ \Omega$, $C_L = 5\ \text{pF}$, See Figure 4			25	ns
$t_{\text{SK(O)}}$	Output skew between centre port to any other port ⁽²⁾	$R_L = 50\ \Omega$, $C_L = 5\ \text{pF}$, See Figure 9		50		ps
$t_{\text{SK(P)}}$	Skew between opposite transitions of the same output ($t_{\text{PHL}} - t_{\text{PLH}}$) ⁽²⁾	$R_L = 50\ \Omega$, $C_L = 5\ \text{pF}$, See Figure 9		20		ps
t_{J}	Total jitter ⁽²⁾	$R_L = 50\ \Omega$, $C_L = 5\ \text{pF}$, $t_{\text{R}} = t_{\text{F}} = 500\ \text{ps}$ at 480 Mbps (PRBS = $2^{15} - 1$)		200		ps
$V_{\text{CC}} = 3.3\ \text{V} \pm 10\%$						
t_{pd}	Propagation delay ⁽²⁾⁽³⁾	$R_L = 50\ \Omega$, $C_L = 5\ \text{pF}$, See Figure 8		0.25		ns
t_{ON}	Line enable time, $\overline{\text{OE}}$ to D, nD	$R_L = 50\ \Omega$, $C_L = 5\ \text{pF}$, See Figure 4			30	ns
t_{OFF}	Line disable time, $\overline{\text{OE}}$ to D, nD	$R_L = 50\ \Omega$, $C_L = 5\ \text{pF}$, See Figure 4			25	ns
$t_{\text{SK(O)}}$	Output skew between centre port to any other port ⁽²⁾	$R_L = 50\ \Omega$, $C_L = 5\ \text{pF}$, See Figure 9		50		ps
$t_{\text{SK(P)}}$	Skew between opposite transitions of the same output ($t_{\text{PHL}} - t_{\text{PLH}}$) ⁽²⁾	$R_L = 50\ \Omega$, $C_L = 5\ \text{pF}$, See Figure 9		20		ps
t_{J}	Total jitter ⁽²⁾	$R_L = 50\ \Omega$, $C_L = 5\ \text{pF}$, $t_{\text{R}} = t_{\text{F}} = 500\ \text{ps}$ at 480 Mbps (PRBS = $2^{15} - 1$)		200		ps

(1) For Max or Min conditions, use the appropriate value specified under [Electrical Characteristics](#) for the applicable device type.

(2) Specified by design

(3) The bus switch contributes no propagational delay other than the RC delay of the on resistance of the switch and the load capacitance. The time constant for the switch alone is of the order of 0.25 ns for 10-pF load. Since this time constant is much smaller than the rise and fall times of typical driving signals, it adds very little propagational delay to the system. Propagational delay of the bus switch, when used in a system, is determined by the driving circuit on the driving side of the switch and its interactions with the load on the driven side.

7 Application Information

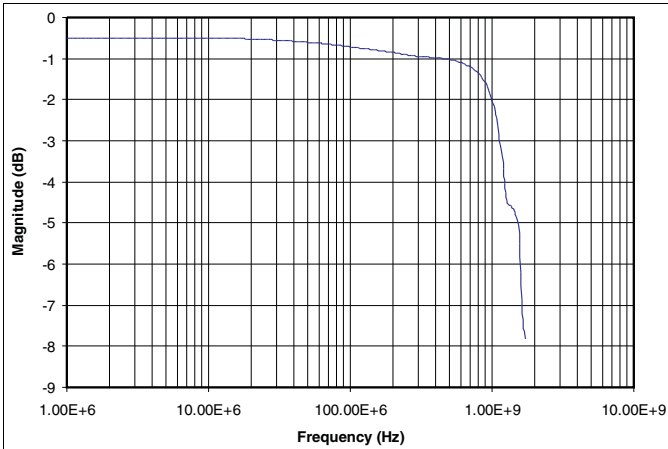

Figure 1. Insertion Loss

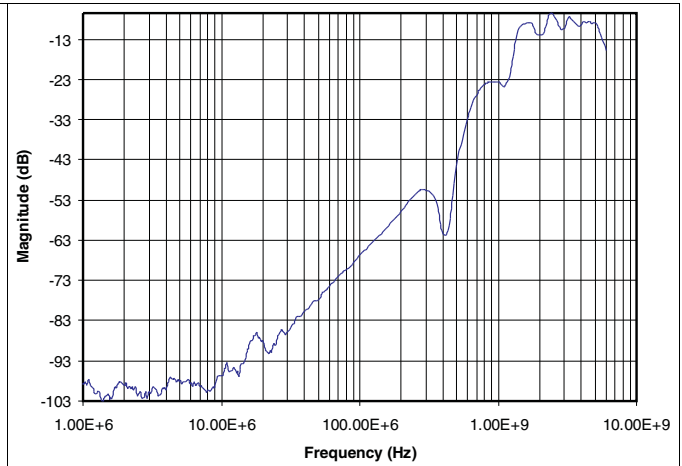

Figure 2. OFF Isolation

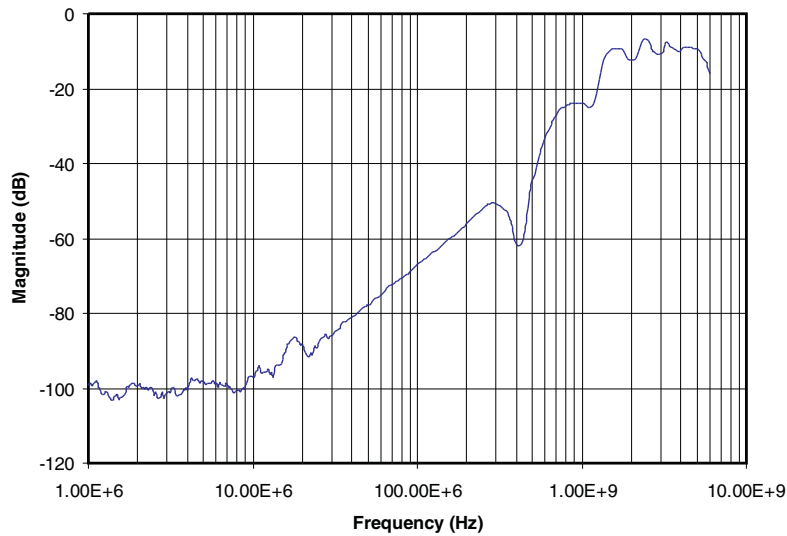
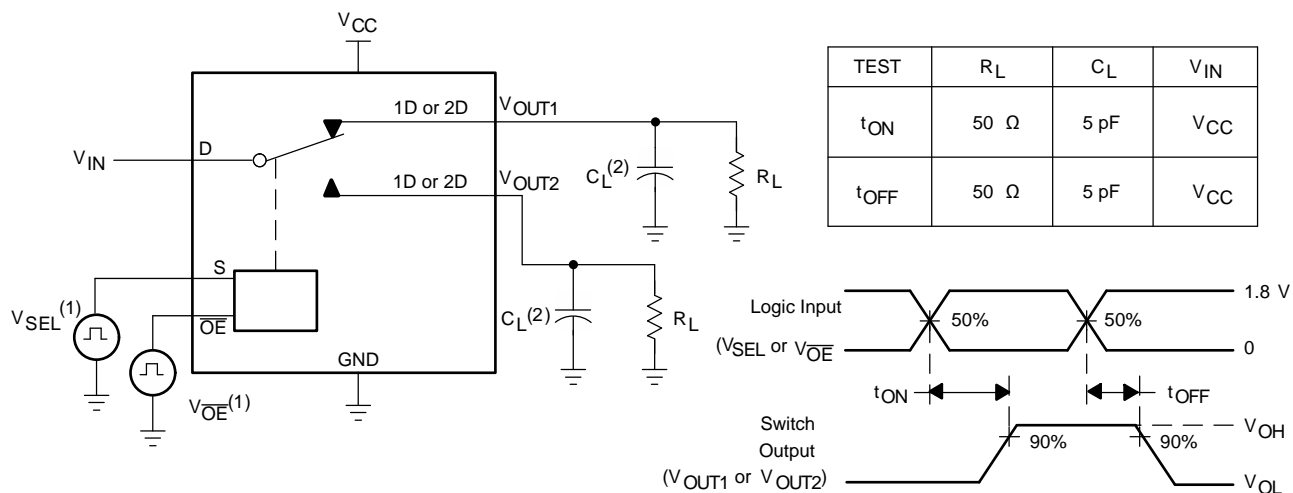

Figure 3. Crosstalk

8 Parameter Measurement Information



- (1) All input pulses are supplied by generators having the following characteristics: PRR ≤ 10 MHz, ZO = 50 Ω, tr < 5 ns, tf < 5 ns.
- (2) CL includes probe and jig capacitance.

Figure 4. Turnon (tON) and Turnoff Time (tOFF)

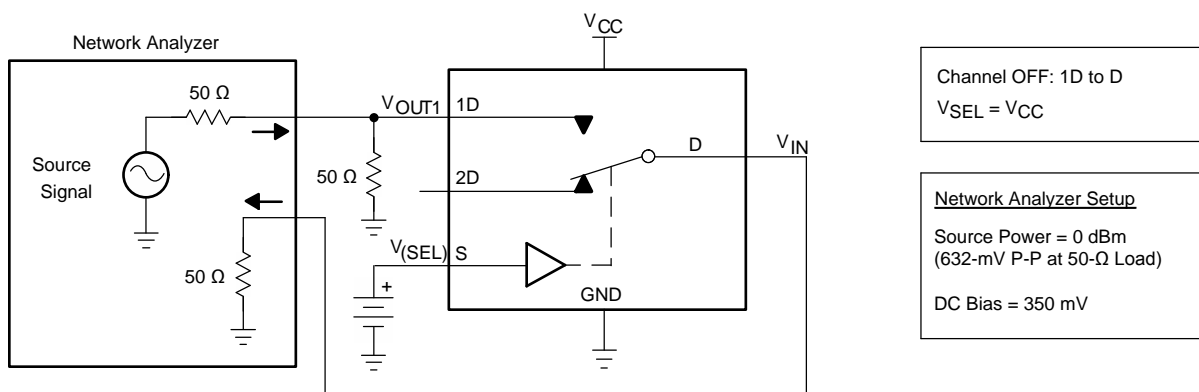

Figure 5. OFF Isolation (OIRR)

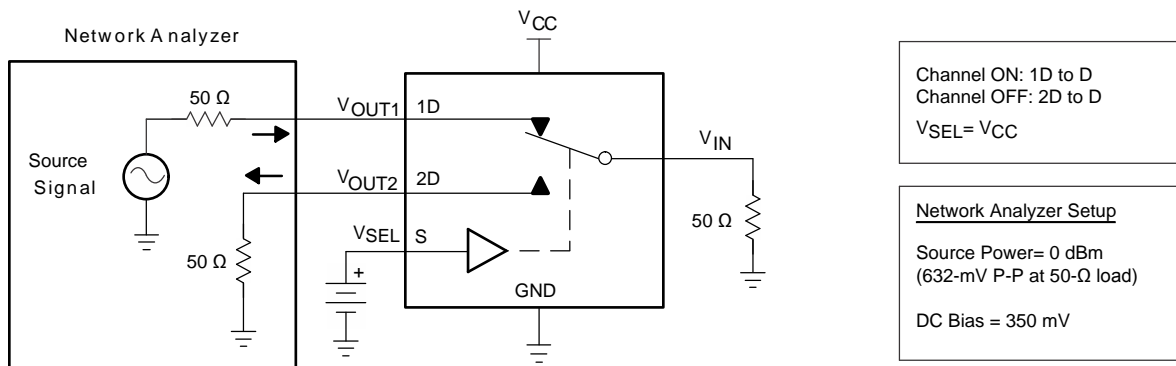

Figure 6. Crosstalk (XTALK)

Parameter Measurement Information (continued)

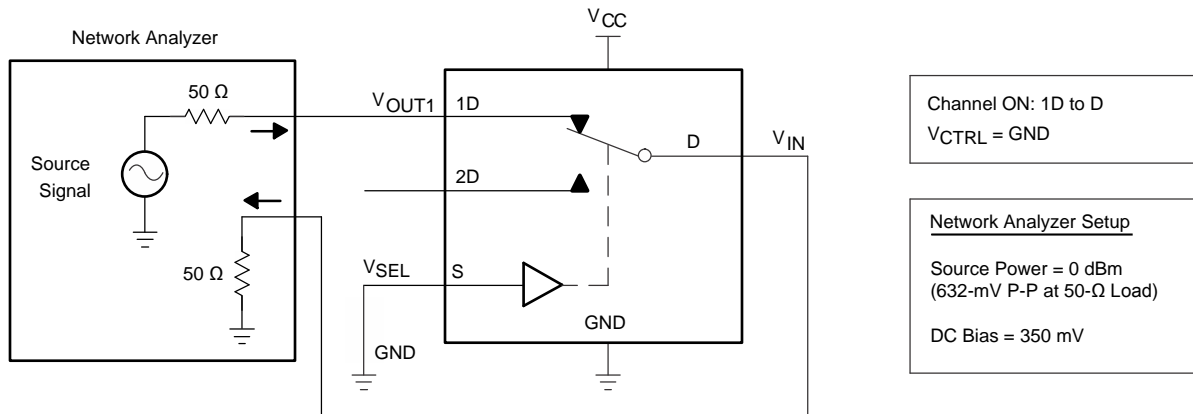

Figure 7. Bandwidth (BW)

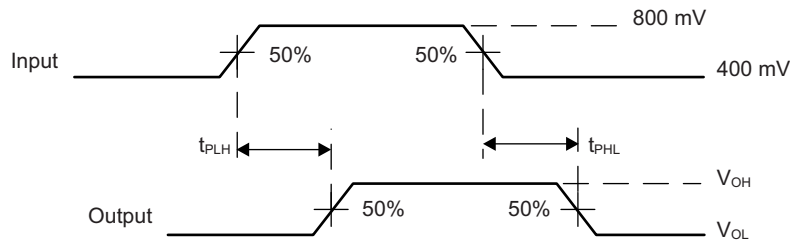

Figure 8. Propagation Delay

Parameter Measurement Information (continued)

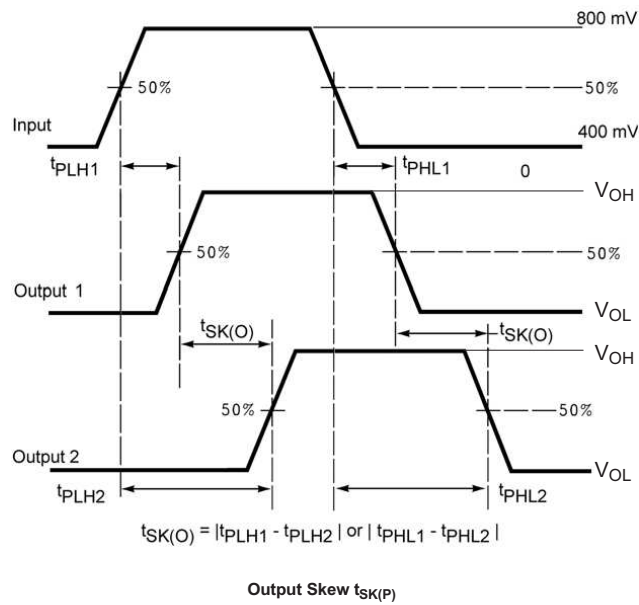
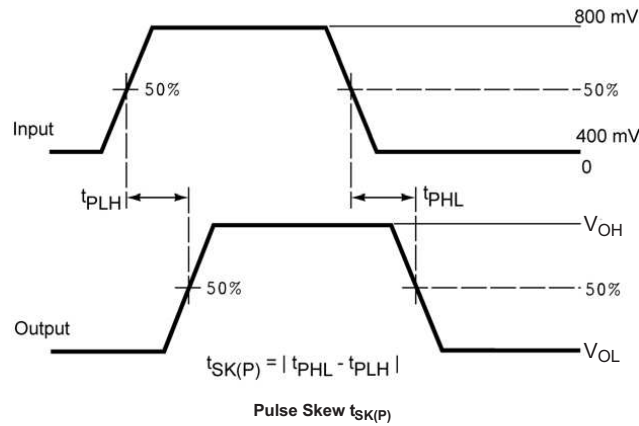

Figure 9. Skew Test

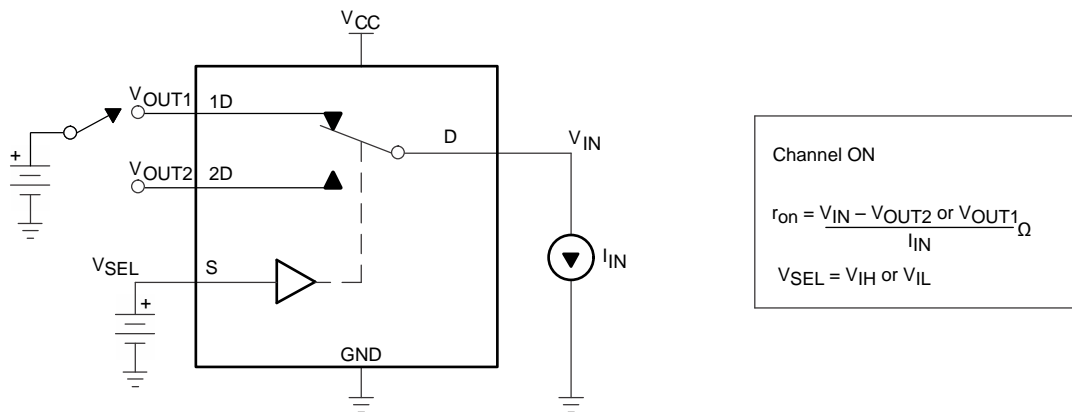

Figure 10. ON-State Resistance (r_{on})

Parameter Measurement Information (continued)

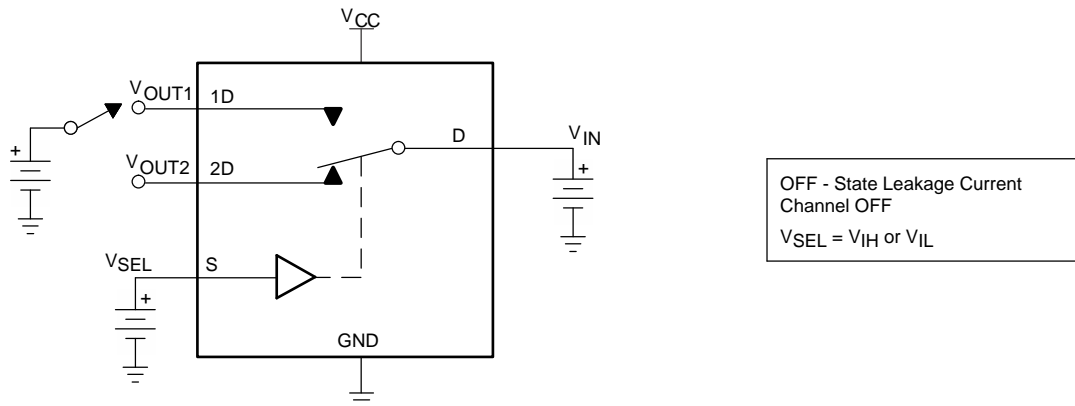

Figure 11. OFF-State Leakage Current

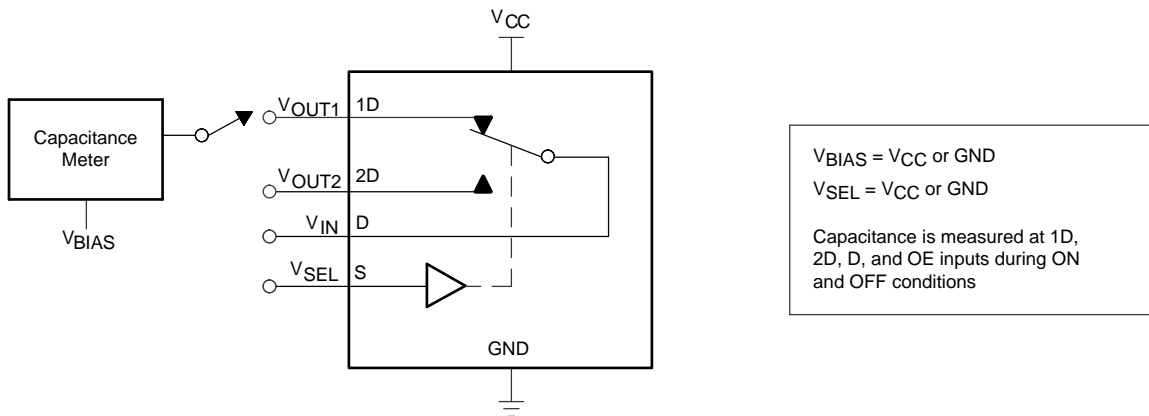

Figure 12. Capacitance

9 Detailed Description

9.1 Overview

The TS3USB31E is a 1:1 SPST high-bandwidth switch specially designed for the switching of high-speed USB 2.0 signals. The switch is bidirectional and offers little or no attenuation of the high-speed signals. It is designed for low bit-to-bit skew and high channel-to-channel noise isolation, and is compatible with various standards, such as high-speed USB 2.0 (480 Mbps).

9.2 Functional Block Diagram

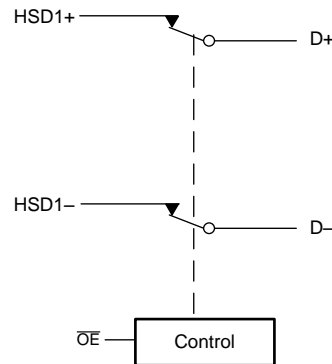

Copyright © 2016, Texas Instruments Incorporated

9.3 Feature Description

9.3.1 I_{OFF} Supports Partial Power-Down Mode Operation

When $V_{CC} = 0$ V, the signal path is placed in a high impedance state which isolates the bus. This allows signals to be present on the D_{\pm} and HSD_{\pm} pins before the device is powered up without damaging the device.

9.4 Device Functional Modes

The TS3USB31E device has two modes that are digitally controlled by the OE pin. Setting the OE pin *High* isolates the signal path by a high impedance state. See [Table 1](#).

Table 1. Truth Table

\overline{OE}	FUNCTION
H	Disconnect
L	$D+$, $D-$ = $HSD+$, $HSD-$

10 Application and Implementation

NOTE

Information in the following applications sections is not part of the TI component specification, and TI does not warrant its accuracy or completeness. TI's customers are responsible for determining suitability of components for their purposes. Customers should validate and test their design implementation to confirm system functionality.

10.1 Application Information

The TS3USB31E device is used to isolate a USB bus when it is not in use to prevent two different USB devices from interfering with each other.

10.2 Typical Application

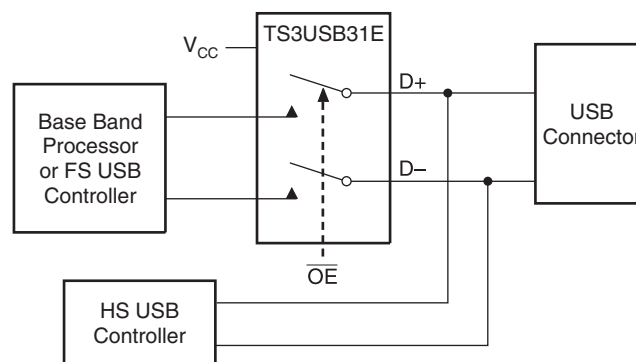

Figure 13. Application Diagram

10.2.1 Design Requirements

Design requirements of the USB 1.0, 1.1, and 2.0 standards must be followed. TI recommends that the digital control pin OE be pulled up to V_{CC} or down to ground to avoid undesired switch positions that could result from the floating pin.

10.2.2 Detailed Design Procedure

The TS3USB31E can be properly operated without any external components. However, it is recommended that unused pins be connected to ground through a 50-Ω resistor to prevent signal reflections back into the device.

The N.C pin must be left floating.

Typical Application (continued)

10.2.3 Application Curves

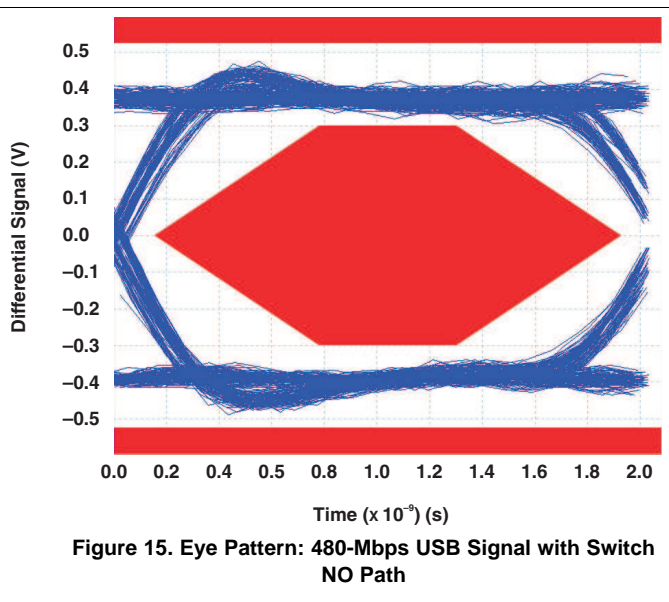
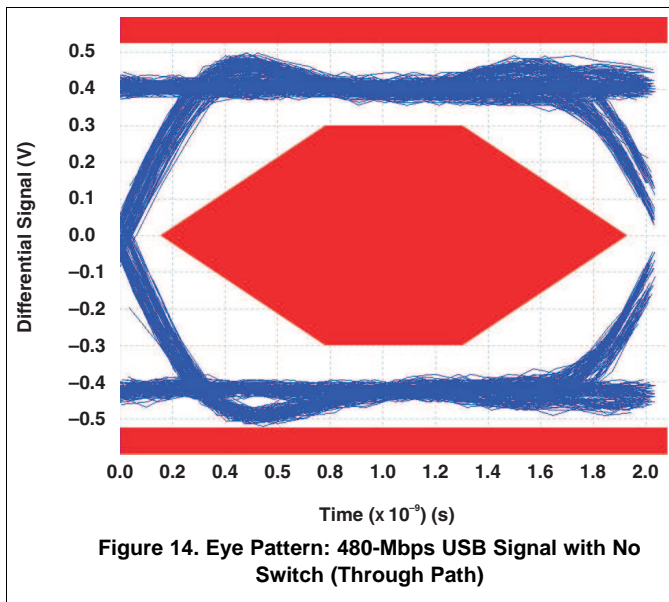

11 Power Supply Recommendations

Power to the device is supplied through the V_{CC} pin. TI recommends placing a bypass capacitor as close as possible to the supply pin V_{CC} to help smooth out lower frequency noise to provide better load regulation across the frequency spectrum.

This device doesn't require any power sequencing with respect to other devices in the system due to its power off isolation feature which allows signals to be present on the D_{\pm} and HSD_{\pm} pins before the device is powered up without damaging the device.

12 Layout

12.1 Layout Guidelines

Place supply bypass capacitors as close to V_{CC} pin as possible and avoid placing the bypass caps near the $D+$ and $D-$ traces.

The high-speed $D+$ and $D-$ traces must always be of equal length and must be no more than 4 inches; otherwise, the eye diagram performance may be degraded. A high-speed USB connection is made through a shielded, twisted pair cable with a differential characteristic impedance. In layout, the impedance of $D+$ and $D-$ traces must match the cable characteristic differential impedance for optimal performance.

Route the high-speed USB signals using a minimum of vias and corners which reduces signal reflections and impedance changes. When a via must be used, increase the clearance size around it to minimize its capacitance. Each via introduces discontinuities in the transmission line of the signal and increases the chance of picking up interference from the other layers of the board. Be careful when designing test points on twisted pair lines; through-hole pins are not recommended.

When it becomes necessary to turn 90° , use two 45° turns or an arc instead of making a single 90° turn. This reduces reflections on the signal traces by minimizing impedance discontinuities.

Do not route USB traces under or near crystals, oscillators, clock signal generators, switching regulators, mounting holes, magnetic devices, or IC's that use or duplicate clock signals.

Avoid stubs on the high-speed USB signals because they cause signal reflections. If a stub is unavoidable, then the stub must be less than 200 mm.

Route all high-speed USB signal traces over continuous planes (V_{CC} or GND), with no interruptions.

Avoid crossing over anti-etch, commonly found with plane splits.

Due to high frequencies associated with the USB, a printed circuit board with at least four layers is recommended: two signal layers separated by a ground layer and a power layer. The majority of signal traces must run on a single layer, preferably top layer. Immediately next to this layer must be the GND plane, which is solid with no cuts. Avoid running signal traces across a split in the ground or power plane. When running across split planes is unavoidable, sufficient decoupling must be used. Minimizing the number of signal vias reduces EMI by reducing inductance at high frequencies. For more information on layout guidelines, see [High Speed Layout Guidelines](#) (SCAA082) and [USB 2.0 Board Design and Layout Guidelines](#) (SPRAAR7).

12.2 Layout Example

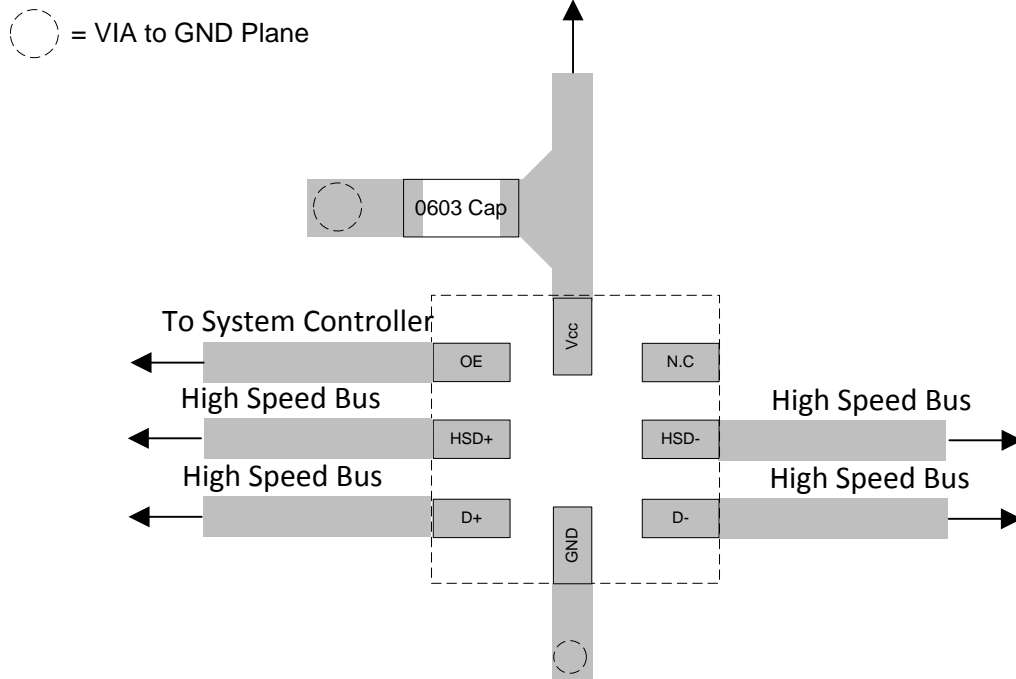

Figure 16. Layout Recommendation

13 Device and Documentation Support

13.1 Documentation Support

13.1.1 Related Documentation

For related documentation see the following

- [High Speed Layout Guidelines](#)
- [USB 2.0 Board Design and Layout Guidelines](#)

13.2 Receiving Notification of Documentation Updates

To receive notification of documentation updates, navigate to the device product folder on ti.com. In the upper right corner, click on *Alert me* to register and receive a weekly digest of any product information that has changed. For change details, review the revision history included in any revised document.

13.3 Community Resource

The following links connect to TI community resources. Linked contents are provided "AS IS" by the respective contributors. They do not constitute TI specifications and do not necessarily reflect TI's views; see TI's [Terms of Use](#).

TI E2E™ Online Community *TI's Engineer-to-Engineer (E2E) Community*. Created to foster collaboration among engineers. At e2e.ti.com, you can ask questions, share knowledge, explore ideas and help solve problems with fellow engineers.

Design Support *TI's Design Support* Quickly find helpful E2E forums along with design support tools and contact information for technical support.

13.4 Trademarks

E2E is a trademark of Texas Instruments.
All other trademarks are the property of their respective owners.

13.5 Electrostatic Discharge Caution



These devices have limited built-in ESD protection. The leads should be shorted together or the device placed in conductive foam during storage or handling to prevent electrostatic damage to the MOS gates.

13.6 Glossary

[SLYZ022](#) — *TI Glossary*.

This glossary lists and explains terms, acronyms, and definitions.

14 Mechanical, Packaging, and Orderable Information

The following pages include mechanical, packaging, and orderable information. This information is the most current data available for the designated devices. This data is subject to change without notice and revision of this document. For browser-based versions of this data sheet, refer to the left-hand navigation.

PACKAGING INFORMATION

Orderable Device	Status (1)	Package Type	Package Drawing	Pins	Package Qty	Eco Plan (2)	Lead finish/ Ball material (6)	MSL Peak Temp (3)	Op Temp (°C)	Device Marking (4/5)	Samples
TS3USB31ERSER	ACTIVE	UQFN	RSE	8	3000	RoHS & Green	NIPDAUAG	Level-1-260C-UNLIM	-40 to 85	LJ	Samples

(1) The marketing status values are defined as follows:

ACTIVE: Product device recommended for new designs.

LIFEBUY: TI has announced that the device will be discontinued, and a lifetime-buy period is in effect.

NRND: Not recommended for new designs. Device is in production to support existing customers, but TI does not recommend using this part in a new design.

PREVIEW: Device has been announced but is not in production. Samples may or may not be available.

OBSELETE: TI has discontinued the production of the device.

(2) **RoHS:** TI defines "RoHS" to mean semiconductor products that are compliant with the current EU RoHS requirements for all 10 RoHS substances, including the requirement that RoHS substance do not exceed 0.1% by weight in homogeneous materials. Where designed to be soldered at high temperatures, "RoHS" products are suitable for use in specified lead-free processes. TI may reference these types of products as "Pb-Free".

RoHS Exempt: TI defines "RoHS Exempt" to mean products that contain lead but are compliant with EU RoHS pursuant to a specific EU RoHS exemption.

Green: TI defines "Green" to mean the content of Chlorine (Cl) and Bromine (Br) based flame retardants meet JS709B low halogen requirements of <=1000ppm threshold. Antimony trioxide based flame retardants must also meet the <=1000ppm threshold requirement.

(3) MSL, Peak Temp. - The Moisture Sensitivity Level rating according to the JEDEC industry standard classifications, and peak solder temperature.

(4) There may be additional marking, which relates to the logo, the lot trace code information, or the environmental category on the device.

(5) Multiple Device Markings will be inside parentheses. Only one Device Marking contained in parentheses and separated by a "-" will appear on a device. If a line is indented then it is a continuation of the previous line and the two combined represent the entire Device Marking for that device.

(6) Lead finish/Ball material - Orderable Devices may have multiple material finish options. Finish options are separated by a vertical ruled line. Lead finish/Ball material values may wrap to two lines if the finish value exceeds the maximum column width.

Important Information and Disclaimer:The information provided on this page represents TI's knowledge and belief as of the date that it is provided. TI bases its knowledge and belief on information provided by third parties, and makes no representation or warranty as to the accuracy of such information. Efforts are underway to better integrate information from third parties. TI has taken and continues to take reasonable steps to provide representative and accurate information but may not have conducted destructive testing or chemical analysis on incoming materials and chemicals. TI and TI suppliers consider certain information to be proprietary, and thus CAS numbers and other limited information may not be available for release.

In no event shall TI's liability arising out of such information exceed the total purchase price of the TI part(s) at issue in this document sold by TI to Customer on an annual basis.

TAPE AND REEL INFORMATION



QUADRANT ASSIGNMENTS FOR PIN 1 ORIENTATION IN TAPE



*All dimensions are nominal

Device	Package Type	Package Drawing	Pins	SPQ	Reel Diameter (mm)	Reel Width W1 (mm)	A0 (mm)	B0 (mm)	K0 (mm)	P1 (mm)	W (mm)	Pin1 Quadrant
TS3USB31ERSER	UQFN	RSE	8	3000	180.0	8.4	1.7	1.7	0.7	4.0	8.0	Q2

TAPE AND REEL BOX DIMENSIONS



*All dimensions are nominal

Device	Package Type	Package Drawing	Pins	SPQ	Length (mm)	Width (mm)	Height (mm)
TS3USB31ERSER	UQFN	RSE	8	3000	202.0	201.0	28.0

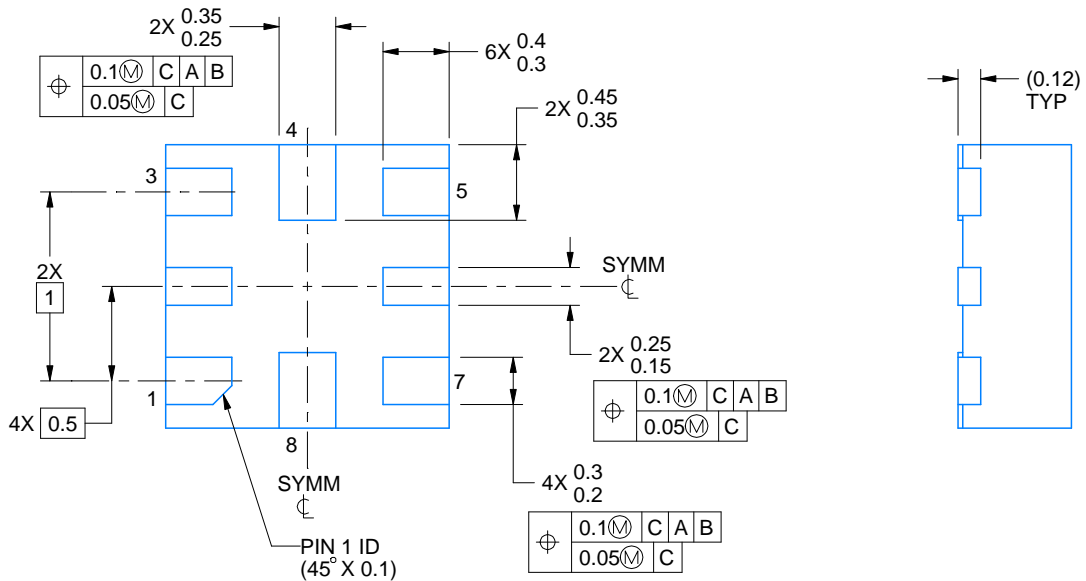
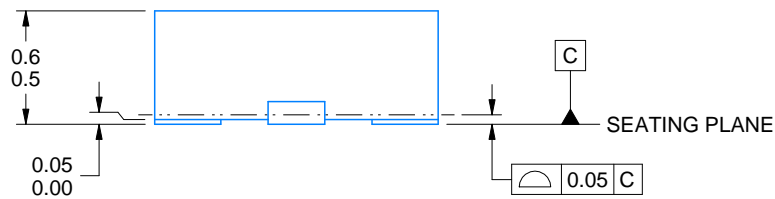
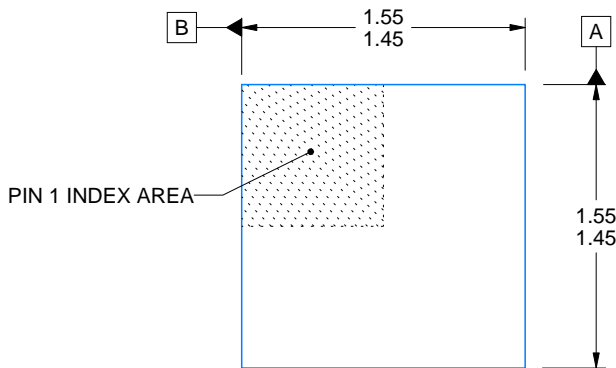
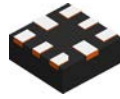

4220323/B 03/2018

NOTES:

1. All linear dimensions are in millimeters. Any dimensions in parenthesis are for reference only. Dimensioning and tolerancing per ASME Y14.5M.
2. This drawing is subject to change without notice.

EXAMPLE BOARD LAYOUT

RSE0008A

UQFN - 0.6 mm max height

PLASTIC QUAD FLATPACK - NO LEAD

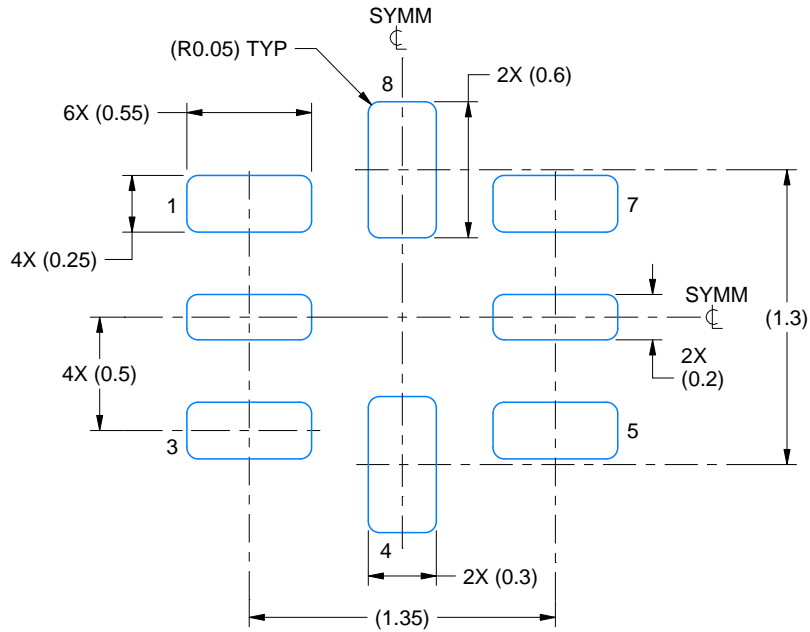

LAND PATTERN EXAMPLE
SCALE:30X

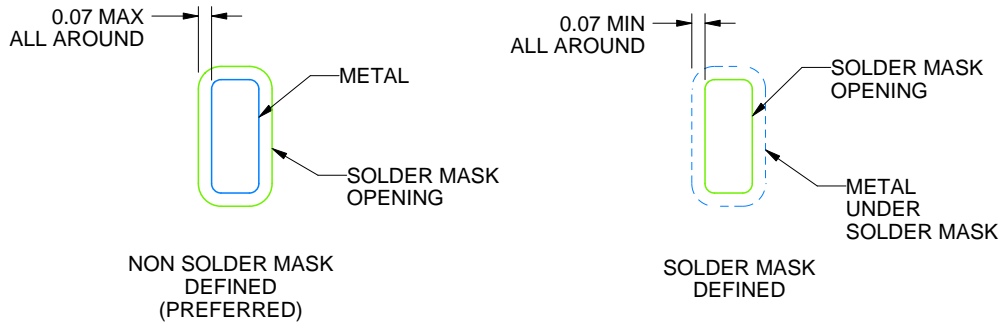

SOLDER MASK DETAILS
NOT TO SCALE

4220323/B 03/2018

NOTES: (continued)

3. For more information, see Texas Instruments literature number SLUA271 (www.ti.com/lit/slua271).

EXAMPLE STENCIL DESIGN

RSE0008A

UQFN - 0.6 mm max height

PLASTIC QUAD FLATPACK - NO LEAD

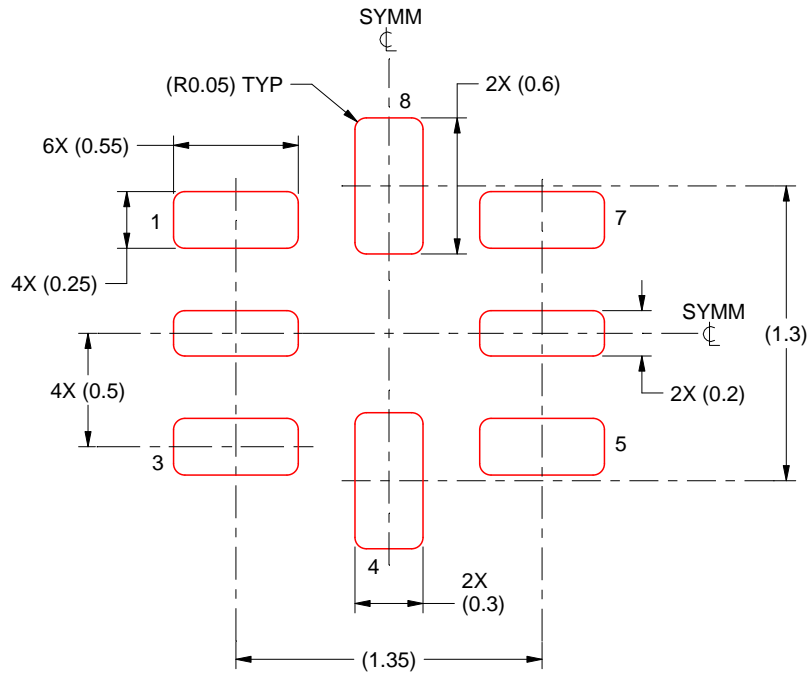

SOLDER PASTE EXAMPLE
BASED ON 0.1 mm THICKNESS
SCALE: 30X

4220323/B 03/2018

NOTES: (continued)

5. Laser cutting apertures with trapezoidal walls and rounded corners may offer better paste release. IPC-7525 may have alternate design recommendations.

IMPORTANT NOTICE AND DISCLAIMER

TI PROVIDES TECHNICAL AND RELIABILITY DATA (INCLUDING DATASHEETS), DESIGN RESOURCES (INCLUDING REFERENCE DESIGNS), APPLICATION OR OTHER DESIGN ADVICE, WEB TOOLS, SAFETY INFORMATION, AND OTHER RESOURCES "AS IS" AND WITH ALL FAULTS, AND DISCLAIMS ALL WARRANTIES, EXPRESS AND IMPLIED, INCLUDING WITHOUT LIMITATION ANY IMPLIED WARRANTIES OF MERCHANTABILITY, FITNESS FOR A PARTICULAR PURPOSE OR NON-INFRINGEMENT OF THIRD PARTY INTELLECTUAL PROPERTY RIGHTS.

These resources are intended for skilled developers designing with TI products. You are solely responsible for (1) selecting the appropriate TI products for your application, (2) designing, validating and testing your application, and (3) ensuring your application meets applicable standards, and any other safety, security, or other requirements. These resources are subject to change without notice. TI grants you permission to use these resources only for development of an application that uses the TI products described in the resource. Other reproduction and display of these resources is prohibited. No license is granted to any other TI intellectual property right or to any third party intellectual property right. TI disclaims responsibility for, and you will fully indemnify TI and its representatives against, any claims, damages, costs, losses, and liabilities arising out of your use of these resources.

TI's products are provided subject to TI's Terms of Sale (www.ti.com/legal/termsofsale.html) or other applicable terms available either on ti.com or provided in conjunction with such TI products. TI's provision of these resources does not expand or otherwise alter TI's applicable warranties or warranty disclaimers for TI products.

Mailing Address: Texas Instruments, Post Office Box 655303, Dallas, Texas 75265
Copyright © 2020, Texas Instruments Incorporated

Looking for pricing, stock, or lifecycle information?

Click below to explore more details on WIN SOURCE:

 [View TS3USB31ERSER](#) on WIN SOURCE

 [Texas Instruments](#) Information

Optimize Your Supply Chain with WIN SOURCE Solutions

-  Global Sourcing Solution
-  Obsolete Management
-  Cost Control Management
-  Shortage Management
-  Alternative Solution
-  Excess Inventory Management