



**THE DATASHEET OF  
TS3L501ERUAR**



# TS3L501E 8-Channel SPDT/16-Bit to 8-Bit Multiplexer and Demultiplexer Ethernet LAN Switch With Power-Down Mode

## 1 Features

- Integrated Power-Down Mode
- Wide Bandwidth (BW = 600 MHz Typical)
- Low Crosstalk ( $X_{TALK} = -37$  dB Typical at 250 MHz)
- Low Bit-to-Bit Skew ( $t_{sk(o)} = 100$  ps Maximum)
- Low and Flat ON-State Resistance ( $r_{on} = 4 \Omega$  Typical,  $r_{on(Flat)} = 0.5 \Omega$  Typical)
- Low Input and Output Capacitance ( $C_{ON} = 9$  pF Typical)
- Rail-to-Rail Switching on Data I/O Ports (0 V to 3.6 V)
- $V_{CC}$  Operating Range From 3 V to 3.6 V
- Support Power-Down Mode
- Latch-Up Performance Exceeds 100 mA Per JESD 78, Class II
- ESD Performance (A, B, C, LED pins)
  - $\pm 4$ -kV IEC61000-4-2, Contact Discharge
  - 6-kV Human Body Model Per JESD22-A114E (Switch I/O pins to GND)
- ESD Performance (All pins)
  - 2-kV Human Body Model Per JESD22-A114E

## 2 Applications

- 10, 100, and 1000 Base-T Signal Switching
- Differential (LVDS, LVPECL) Signal Switching
- Audio and Video Switching
- Hub and Router Signal Switching

## 3 Description

The TS3L501E is a 8-channel SPDT analog switch or 16-bit to 8-bit multiplexer or demultiplexer LAN switch with a single select (SEL) input and Power-Down Mode input. The device provides additional I/Os for switching status indicating LED signals and includes high ESD protection. SEL input controls the data path of the multiplexer or demultiplexer. Power-down input can put the device into the standby mode for minimizing current consumption per mode selection.

The device provides a low and flat ON-state resistance ( $r_{on}$ ) and an excellent ON-state resistance match. Low input or output capacitance, high bandwidth, low skew, and low crosstalk among channels make this device suitable for various LAN applications, such as 10/100/1000 Base-T. This device can be used to replace mechanical relays in LAN applications. It also can be used to route signals from a 10/100 Base-T Ethernet transceiver to the RJ-45 LAN connectors in laptops or in docking stations.

It is characterized for operation over the free-air temperature range of  $-40^{\circ}\text{C}$  to  $85^{\circ}\text{C}$ .

### Device Information<sup>(1)</sup>

| PART NUMBER | PACKAGE   | BODY SIZE (NOM)   |
|-------------|-----------|-------------------|
| TS3L501E    | WQFN (42) | 9.00 mm x 3.50 mm |

(1) For all available packages, see the orderable addendum at the end of the data sheet.

### Functional Block Diagram

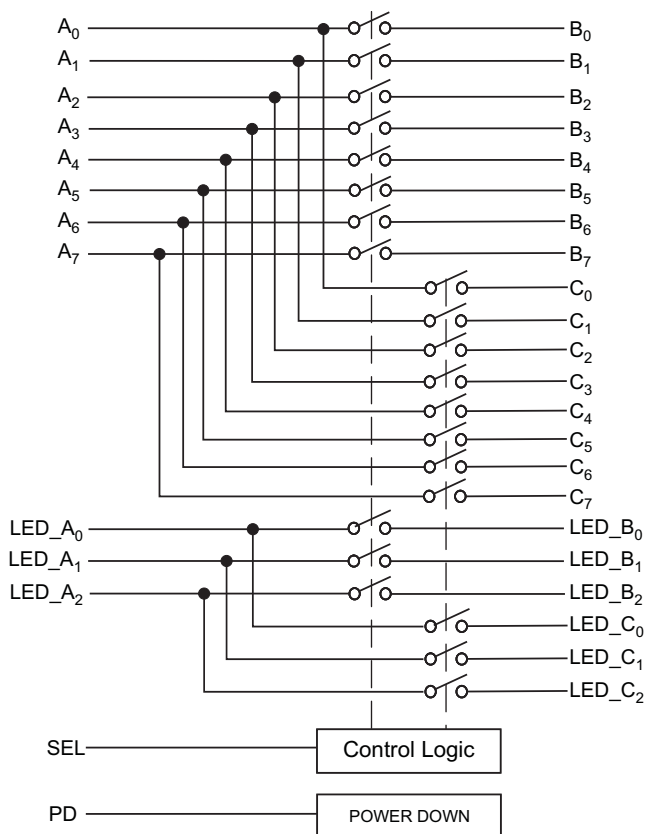

Copyright © 2016, Texas Instruments Incorporated



## Table of Contents

|          |   |           |           |   |           |
|----------|---|-----------|-----------|---|-----------|
| <b>1</b> | <b>Features</b> .....   | <b>1</b>  | 7.5       | HP8753ES Setup .....  | <b>13</b> |
| <b>2</b> | <b>Applications</b> .....   | <b>1</b>  | <b>8</b>  | <b>Detailed Description</b> .....                             | <b>14</b> |
| <b>3</b> | <b>Description</b> .....  | <b>1</b>  | 8.1       | Overview .....  | <b>14</b> |
| <b>4</b> | <b>Revision History</b> .....   | <b>2</b>  | 8.2       | Functional Block Diagram .....                                | <b>14</b> |
| <b>5</b> | <b>Pin Configuration and Functions</b> .....                          | <b>3</b>  | 8.3       | Feature Description .....                                     | <b>14</b> |
| <b>6</b> | <b>Specifications</b> .....   | <b>5</b>  | 8.4       | Device Functional Modes .....                                 | <b>14</b> |
| 6.1      | Absolute Maximum Ratings .....  | <b>5</b>  | <b>9</b>  | <b>Application and Implementation</b> .....                   | <b>15</b> |
| 6.2      | ESD Ratings .....   | <b>5</b>  | 9.1       | Application Information .....                                 | <b>15</b> |
| 6.3      | Recommended Operating Conditions .....                                | <b>5</b>  | 9.2       | Typical Application .....                                     | <b>15</b> |
| 6.4      | Thermal Information .....   | <b>6</b>  | <b>10</b> | <b>Power Supply Recommendations</b> .....                     | <b>17</b> |
| 6.5      | Electrical Characteristics for 1000 Base-T Ethernet Switching .....   | <b>6</b>  | <b>11</b> | <b>Layout</b> .....   | <b>17</b> |
| 6.6      | Electrical Characteristics for 10/100 Base-T Ethernet Switching ..... | <b>6</b>  | 11.1      | Layout Guidelines .....                                       | <b>17</b> |
| 6.7      | Switching Characteristics .....                                       | <b>7</b>  | 11.2      | Layout Example .....  | <b>18</b> |
| 6.8      | Dynamic Characteristics .....   | <b>7</b>  | <b>12</b> | <b>Device and Documentation Support</b> .....                 | <b>19</b> |
| 6.9      | Typical Characteristics .....   | <b>8</b>  | 12.1      | Documentation Support .....                                   | <b>19</b> |
| <b>7</b> | <b>Parameter Measurement Information</b> .....                        | <b>9</b>  | 12.2      | Receiving Notification of Documentation Updates .....         | <b>19</b> |
| 7.1      | Enable and Disable Times .....  | <b>9</b>  | 12.3      | Community Resources .....                                     | <b>19</b> |
| 7.2      | Skew .....  | <b>10</b> | 12.4      | Trademarks .....  | <b>19</b> |
| 7.3      | HP8753ES Setup .....  | <b>11</b> | 12.5      | Electrostatic Discharge Caution .....                         | <b>19</b> |
| 7.4      | HP8753ES Setup .....  | <b>12</b> | 12.6      | Glossary .....  | <b>19</b> |
|          |   |           | <b>13</b> | <b>Mechanical, Packaging, and Orderable Information</b> ..... | <b>19</b> |

## 4 Revision History

NOTE: Page numbers for previous revisions may differ from page numbers in the current version.

| <b>Changes from Revision B (May 2016) to Revision C</b>       |  | <b>Page</b> |
|---|--|-------------|
| •   | Added pin numbers 4, 8, 14, 21, 30, 39 to $V_{DD}$ in the <i>Pin Functions</i> table .....   | <b>4</b>    |
| <b>Changes from Revision A (September 2010) to Revision B</b> |  | <b>Page</b> |
| •   | Added <i>ESD Ratings</i> table, <i>Feature Description</i> section, <i>Device Functional Modes</i> , <i>Application and Implementation</i> section, <i>Power Supply Recommendations</i> section, <i>Layout</i> section, <i>Device and Documentation Support</i> section, and <i>Mechanical, Packaging, and Orderable Information</i> section. .... | <b>1</b>    |
| •   | Removed <i>Ordering Information</i> table .....  | <b>1</b>    |

## 5 Pin Configuration and Functions

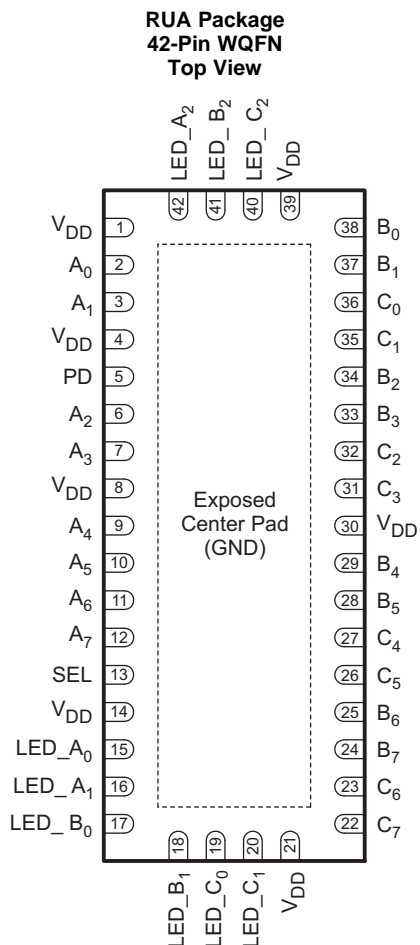

The exposed center pad must be connected to GND.

### Pin Functions

| PIN            |     | I/O | DESCRIPTION                   |
|----------------|-----|-----|-------------------------------|
| NAME           | NO. |     |                               |
| A <sub>0</sub> | 2   | I/O | Port A Common I/O signal path |
| A <sub>1</sub> | 3   | I/O | Port A Common I/O signal path |
| A <sub>2</sub> | 6   | I/O | Port A Common I/O signal path |
| A <sub>3</sub> | 7   | I/O | Port A Common I/O signal path |
| A <sub>4</sub> | 9   | I/O | Port A Common I/O signal path |
| A <sub>5</sub> | 10  | I/O | Port A Common I/O signal path |
| A <sub>6</sub> | 11  | I/O | Port A Common I/O signal path |
| A <sub>7</sub> | 12  | I/O | Port A Common I/O signal path |
| B <sub>0</sub> | 38  | I/O | Port B I/O signal path        |
| B <sub>1</sub> | 37  | I/O | Port B I/O signal path        |
| B <sub>2</sub> | 34  | I/O | Port B I/O signal path        |
| B <sub>3</sub> | 33  | I/O | Port B I/O signal path        |
| B <sub>4</sub> | 29  | I/O | Port B I/O signal path        |
| B <sub>5</sub> | 28  | I/O | Port B I/O signal path        |
| B <sub>6</sub> | 25  | I/O | Port B I/O signal path        |

**Pin Functions (continued)**

| PIN                |                         | I/O   | DESCRIPTION  |
|--------------------|-------------------------|-------|--|
| NAME               | NO.                     |       |  |
| B <sub>7</sub>     | 24                      | I/O   | Port B I/O signal path   |
| C <sub>0</sub>     | 36                      | I/O   | Port C I/O signal path   |
| C <sub>1</sub>     | 35                      | I/O   | Port C I/O signal path   |
| C <sub>2</sub>     | 32                      | I/O   | Port C I/O signal path   |
| C <sub>3</sub>     | 31                      | I/O   | Port C I/O signal path   |
| C <sub>4</sub>     | 27                      | I/O   | Port C I/O signal path   |
| C <sub>5</sub>     | 26                      | I/O   | Port C I/O signal path   |
| C <sub>6</sub>     | 23                      | I/O   | Port C I/O signal path   |
| C <sub>7</sub>     | 22                      | I/O   | Port C I/O signal path   |
| GND                | Exposed Center Pad      | —     | Ground   |
| LED_A <sub>0</sub> | 15                      | I/O   | Port A LED I/O Common signal path, (may also be used as a general purpose signal path) |
| LED_A <sub>1</sub> | 16                      | I/O   | Port A LED Common I/O signal path, (may also be used as a general purpose signal path) |
| LED_A <sub>2</sub> | 42                      | I/O   | Port A LED Common I/O signal path, (may also be used as a general purpose signal path) |
| LED_B <sub>0</sub> | 17                      | I/O   | Port B LED I/O signal path, (may also be used as a general purpose signal path)        |
| LED_B <sub>1</sub> | 18                      | I/O   | Port B LED I/O signal path, (may also be used as a general purpose signal path)        |
| LED_B <sub>2</sub> | 41                      | I/O   | Port B LED I/O signal path, (may also be used as a general purpose signal path)        |
| LED_C <sub>0</sub> | 19                      | I/O   | Port C LED I/O signal path, (may also be used as a general purpose signal path)        |
| LED_C <sub>1</sub> | 20                      | I/O   | Port C LED I/O signal path, (may also be used as a general purpose signal path)        |
| LED_C <sub>2</sub> | 40                      | I/O   | Port C LED I/O signal path, (may also be used as a general purpose signal path)        |
| PD                 | 5                       | Input | Power Down Input, Active High  |
| SEL                | 13                      | Input | Select Input   |
| V <sub>DD</sub>    | 1, 4, 8, 14, 21, 30, 39 | —     | Power  |

## 6 Specifications

### 6.1 Absolute Maximum Ratings

over operating free-air temperature range (unless otherwise noted)<sup>(1)</sup>

|                  |   | MIN                  | MAX  | UNIT |
|------------------|---|----------------------|------|------|
| V <sub>DD</sub>  | Supply voltage                                    | -0.5                 | 4.6  | V    |
| V <sub>IN</sub>  | Control input voltage <sup>(2) (3)</sup>          | -0.5                 | 7    | V    |
| V <sub>I/O</sub> | Switch I/O voltage <sup>(2) (3) (4)</sup>         | -0.5                 | 7    | V    |
| I <sub>IK</sub>  | Control input clamp current                       | V <sub>IN</sub> < 0  |      | mA   |
| I <sub>I/O</sub> | I/O port clamp current                            | V <sub>I/O</sub> < 0 |      | mA   |
| I <sub>I/O</sub> | ON-state switch current <sup>(5)</sup>            |                      | ±128 | mA   |
|                  | Continuous current through V <sub>DD</sub> or GND |                      | ±100 | mA   |
| T <sub>stg</sub> | Storage temperature                               | -65                  | 150  | °C   |

- (1) Stresses beyond those listed under *Absolute Maximum Ratings* may cause permanent damage to the device. These are stress ratings only, which do not imply functional operation of the device at these or any other conditions beyond those indicated under *Recommended Operating Conditions*. Exposure to absolute-maximum-rated conditions for extended periods may affect device reliability.
- (2) All voltages are with respect to ground, unless otherwise specified.
- (3) The input and output voltage ratings may be exceeded if the input and output clamp-current ratings are observed.
- (4) V<sub>I</sub> and V<sub>O</sub> are used to denote specific conditions for V<sub>I/O</sub>.
- (5) I<sub>I</sub> and I<sub>O</sub> are used to denote specific conditions for I<sub>I/O</sub>.

### 6.2 ESD Ratings

|                    |                         |  | VALUE  | UNIT  |   |
|--------------------|-------------------------|--|--|-------|---|
| V <sub>(ESD)</sub> | Electrostatic discharge | Human-body model (HBM), per ANSI/ESDA/JEDEC JS-001 <sup>(1)</sup>              | All pins except 1, 4, 5, 8, 13, 14, 21, 30, and 39 | ±6000 | V |
|                    |                         |  | Pins 1, 4, 5, 8, 13, 14, 21, 30, and 39            |       |   |
|                    |                         | Charged-device model (CDM), per JEDEC specification JESD22-C101 <sup>(2)</sup> |  | ±1500 |   |

- (1) JEDEC document JEP155 states that 500-V HBM allows safe manufacturing with a standard ESD control process.
- (2) JEDEC document JEP157 states that 250-V CDM allows safe manufacturing with a standard ESD control process.

### 6.3 Recommended Operating Conditions

over operating free-air temperature range (unless otherwise noted)<sup>(1)</sup>

|                  |  | MIN | MAX             | UNIT |
|------------------|--|-----|-----------------|------|
| V <sub>DD</sub>  | Supply voltage                         | 3   | 3.6             | V    |
| V <sub>IH</sub>  | High-level control input voltage (SEL) | 2   | 5.5             | V    |
| V <sub>IL</sub>  | Low-level control input voltage (SEL)  | 0   | 0.8             | V    |
| V <sub>IN</sub>  | Input voltage (SEL)                    | 0   | 5.5             | V    |
| V <sub>I/O</sub> | Input or output voltage                | 0   | V <sub>DD</sub> | V    |
| T <sub>A</sub>   | Operating free-air temperature         | -40 | 85              | °C   |

- (1) All unused control inputs of the device must be held at V<sub>DD</sub> or GND to ensure proper device operation. See the TI application report, *Implications of Slow or Floating CMOS Inputs*, [SCBA004](#).

## 6.4 Thermal Information

| THERMAL METRIC <sup>(1)</sup> |   | TS3L501E   | UNIT |
|-------------------------------|---|------------|------|
|                               |   | RUA (WQFN) |      |
|                               |   | 42 PINS    |      |
| R <sub>θJA</sub>              | Junction-to-ambient thermal resistance <sup>(2)</sup> | 30.9       | °C/W |
| R <sub>θJC(top)</sub>         | Junction-to-case (top) thermal resistance             | 12.8       | °C/W |
| R <sub>θJB</sub>              | Junction-to-board thermal resistance                  | 5.2        | °C/W |
| ψ <sub>JT</sub>               | Junction-to-top characterization parameter            | 0.2        | °C/W |
| ψ <sub>JB</sub>               | Junction-to-board characterization parameter          | 5          | °C/W |
| R <sub>θJC(bot)</sub>         | Junction-to-case (bottom) thermal resistance          | 1.5        | °C/W |

- (1) For more information about traditional and new thermal metrics, see the [Semiconductor and IC Package Thermal Metrics](#) application report.
- (2) The package thermal impedance is calculated in accordance with JESD 51-7.

## 6.5 Electrical Characteristics for 1000 Base-T Ethernet Switching

for 1000 Base-T Ethernet switching over recommended operating free-air temperature range, V<sub>DD</sub> = 3.3 V ± 0.3 V (unless otherwise noted)

| PARAMETER                            |             | TEST CONDITIONS <sup>(1)</sup>  | MIN | TYP <sup>(2)</sup> | MAX  | UNIT |
|--------------------------------------|-------------|---|-----|--------------------|------|------|
| V <sub>IK</sub>                      | SEL, PD     | V <sub>DD</sub> = 3.6 V, I <sub>IN</sub> = -18 mA   |     | -0.7               | -1.2 | V    |
| I <sub>IH</sub>                      | SEL, PD     | V <sub>DD</sub> = 3.6 V, V <sub>IN</sub> = V <sub>DD</sub>                                  |     |                    | ±2   | μA   |
| I <sub>IL</sub>                      | SEL, PD     | V <sub>DD</sub> = 3.6 V, V <sub>IN</sub> = GND  |     |                    | ±1   | μA   |
| I <sub>OFF</sub>                     | SEL, PD     | V <sub>DD</sub> = 0 V, V <sub>IN</sub> = 0 to 3.6 V   |     |                    | ±1   | μA   |
| I <sub>CC</sub>                      |             | V <sub>DD</sub> = 3.6 V, I <sub>I/O</sub> = 0, switch ON or OFF                             |     | 250                | 600  | μA   |
| I <sub>CC_PD</sub>                   |             | V <sub>DD</sub> = 3.6 V, V <sub>IN</sub> = 3.6 V, PD = high                                 |     | 1                  |      |      |
| C <sub>IN</sub>                      | SEL, PD     | f = 1 MHz, V <sub>IN</sub> = 0  |     | 2.6                | 3    | pF   |
| C <sub>OFF</sub>                     | B or C port | V <sub>I</sub> = 0, f = 1 MHz, outputs open, switch OFF                                     |     | 3                  | 4    | pF   |
| C <sub>ON</sub>                      |             | V <sub>I</sub> = 0, f = 1 MHz, outputs open, switch ON                                      |     | 9                  | 9.8  | pF   |
| r <sub>on</sub>                      |             | V <sub>DD</sub> = 3 V, 1.5 V ≤ V <sub>I</sub> ≤ V <sub>DD</sub> , I <sub>O</sub> = -40 mA   |     | 4                  | 8    | Ω    |
| r <sub>on(flat)</sub> <sup>(3)</sup> |             | V <sub>DD</sub> = 3 V, V <sub>I</sub> = 1.5 V and V <sub>DD</sub> , I <sub>O</sub> = -40 mA |     | 0.7                |      | Ω    |
| Δr <sub>on</sub> <sup>(4)</sup>      |             | V <sub>DD</sub> = 3 V, 1.5 V ≤ V <sub>I</sub> ≤ V <sub>DD</sub> , I <sub>O</sub> = -40 mA   |     | 0.8                | 1.5  | Ω    |

- (1) V<sub>I</sub>, V<sub>O</sub>, I<sub>I</sub>, and I<sub>O</sub> refer to I/O pins. V<sub>IN</sub> refers to the control inputs.
- (2) All typical values are at V<sub>DD</sub> = 3.3 V (unless otherwise noted), T<sub>A</sub> = 25°C.
- (3) r<sub>on(flat)</sub> is the difference of r<sub>on</sub> in a given channel at specified voltages.
- (4) Δr<sub>on</sub> is the difference of r<sub>on</sub> from center (A<sub>4</sub>, A<sub>5</sub>) ports to any other port.

## 6.6 Electrical Characteristics for 10/100 Base-T Ethernet Switching

for 10/100 Base-T Ethernet switching over recommended operating free-air temperature range, V<sub>DD</sub> = 3.3 V ± 0.3 V (unless otherwise noted)

| PARAMETER                            |             | TEST CONDITIONS <sup>(1)</sup>   | MIN | TYP <sup>(2)</sup> | MAX  | UNIT |
|--------------------------------------|-------------|--|-----|--------------------|------|------|
| V <sub>IK</sub>                      | SEL, PD     | V <sub>DD</sub> = 3.6 V, I <sub>IN</sub> = -18 mA  |     | -0.7               | -1.2 | V    |
| I <sub>IH</sub>                      | SEL, PD     | V <sub>DD</sub> = 3.6 V, V <sub>IN</sub> = V <sub>DD</sub>   |     |                    | ±2   | μA   |
| I <sub>IL</sub>                      | SEL, PD     | V <sub>DD</sub> = 3.6 V, V <sub>IN</sub> = GND   |     |                    | ±1   | μA   |
| I <sub>OFF</sub>                     | SEL, PD     | V <sub>DD</sub> = 0 V, V <sub>IN</sub> = 0 to 3.6 V  |     |                    | ±1   | μA   |
| I <sub>CC</sub>                      |             | V <sub>DD</sub> = 3.6 V, I <sub>I/O</sub> = 0, switch ON or OFF  |     | 250                | 600  | μA   |
| I <sub>CC_PD</sub>                   |             | V <sub>DD</sub> = 3.6 V, V <sub>IN</sub> = 3.6 V, PD = high  |     | 1                  |      |      |
| C <sub>IN</sub>                      | SEL, PD     | f = 1 MHz, V <sub>IN</sub> = 0   |     | 2.6                | 3.0  | pF   |
| C <sub>OFF</sub>                     | B or C port | V <sub>I</sub> = 0, f = 10 MHz, outputs open, switch OFF   |     | 3                  | 4    | pF   |
| C <sub>ON</sub>                      |             | V <sub>I</sub> = 0, f = 10 MHz, outputs open, switch ON  |     | 9                  | 9.8  | pF   |
| r <sub>on</sub>                      |             | V <sub>DD</sub> = 3 V, 1.25 V ≤ V <sub>I</sub> ≤ V <sub>DD</sub> , I <sub>O</sub> = -10 mA to -30 mA   |     | 4                  | 6    | Ω    |
| r <sub>on(flat)</sub> <sup>(3)</sup> |             | V <sub>DD</sub> = 3 V, V <sub>I</sub> = 1.25 V and V <sub>DD</sub> , I <sub>O</sub> = -10 mA to -30 mA |     | 0.5                |      | Ω    |
| Δr <sub>on</sub> <sup>(4)</sup>      |             | V <sub>DD</sub> = 3 V, 1.25 V ≤ V <sub>I</sub> ≤ V <sub>DD</sub> , I <sub>O</sub> = -10 mA to -30 mA   |     | 0.8                | 1.5  | Ω    |

- (1) V<sub>I</sub>, V<sub>O</sub>, I<sub>I</sub>, and I<sub>O</sub> refer to I/O pins. V<sub>IN</sub> refers to the control inputs.
- (2) All typical values are at V<sub>DD</sub> = 3.3 V (unless otherwise noted), T<sub>A</sub> = 25°C.
- (3) r<sub>on(flat)</sub> is the difference of r<sub>on</sub> in a given channel at specified voltages.
- (4) Δr<sub>on</sub> is the difference of r<sub>on</sub> from center (A<sub>4</sub>, A<sub>5</sub>) ports to any other port.

## 6.7 Switching Characteristics

over recommended operating free-air temperature range,  $V_{DD} = 3.3 \text{ V} \pm 0.3 \text{ V}$ ,  $R_L = 200 \text{ } \Omega$ ,  $C_L = 10 \text{ pF}$   
(unless otherwise noted) (see [Figure 5](#) and [Figure 6](#))

| PARAMETER              | FROM<br>(INPUT) | TO<br>(OUTPUT) | MIN | TYP <sup>(1)</sup> | MAX | UNIT |
|------------------------|-----------------|----------------|-----|--------------------|-----|------|
| $t_{pd}^{(2)}$         | A or B/C        | B/C or A       |     | 0.3                |     | ns   |
| $t_{PZH}$ , $t_{PZL}$  | SEL             | A or B/C       | 0.5 |                    | 15  | ns   |
| $t_{PHZ}$ , $t_{PLZ}$  | SEL             | A or B/C       | 0.9 |                    | 9   | ns   |
| $t_{sk(o)}^{(3)}$      | A or B/C        | B/C or A       |     | 50                 | 100 | ps   |
| $t_{sk(p)}^{(4)}$      | A or B/C        | B/C or A       |     | 50                 | 100 | ps   |
| $t_{ON}/t_{OFF}^{(5)}$ | PD              | A or B/C       |     |                    | 250 | ns   |

- (1) All typical values are at  $V_{DD} = 3.3 \text{ V}$  (unless otherwise noted),  $T_A = 25^\circ\text{C}$ .
- (2) The propagation delay is the calculated RC time constant of the typical ON-state resistance of the switch and the specified load capacitance when driven by an ideal voltage source (zero output impedance).
- (3) Output skew between center port ( $A_4$  to  $A_5$ ) to any other port
- (4) Skew between opposite transitions of the same output in a given device  $|t_{PHL} - t_{PLH}|$
- (5) Device enable/disable time from PD

## 6.8 Dynamic Characteristics

over recommended operating free-air temperature range,  $V_{DD} = 3.3 \text{ V} \pm 0.3 \text{ V}$  (unless otherwise noted)

| PARAMETER  | TEST CONDITIONS   | TYP <sup>(1)</sup> | UNIT |
|------------|---|--------------------|------|
| $X_{TALK}$ | $R_L = 50 \text{ } \Omega$ , $f = 250 \text{ MHz}$ , see <a href="#">Figure 8</a> | -37                | dB   |
| $O_{IRR}$  | $R_L = 50 \text{ } \Omega$ , $f = 250 \text{ MHz}$ , see <a href="#">Figure 9</a> | -37                | dB   |
| BW         | See <a href="#">Figure 7</a>  | 600                | MHz  |

- (1) All typical values are at  $V_{CC} = 3.3 \text{ V}$  (unless otherwise noted),  $T_A = 25^\circ\text{C}$ .

### 6.9 Typical Characteristics

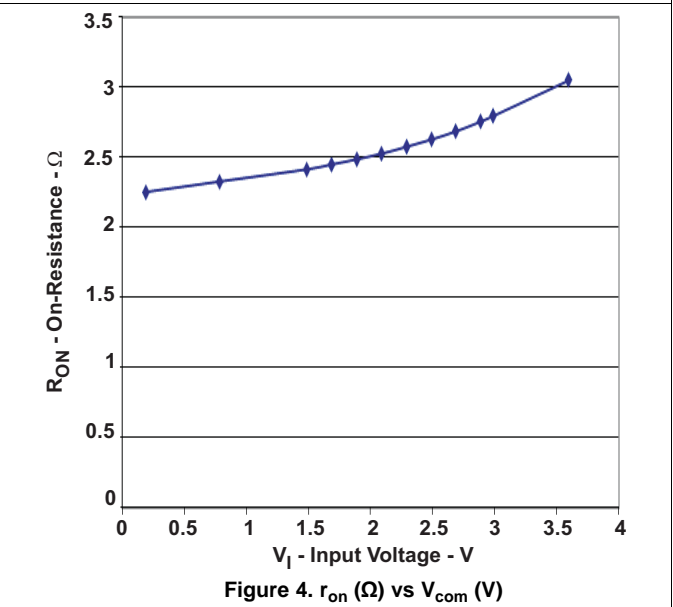
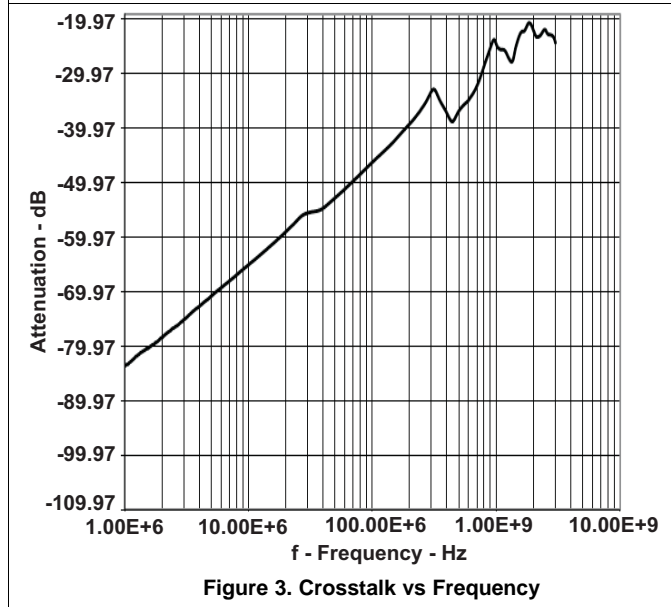
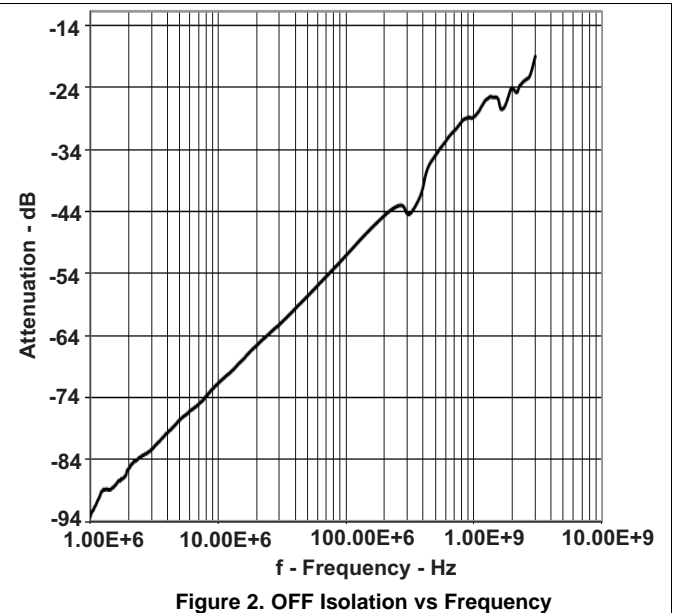
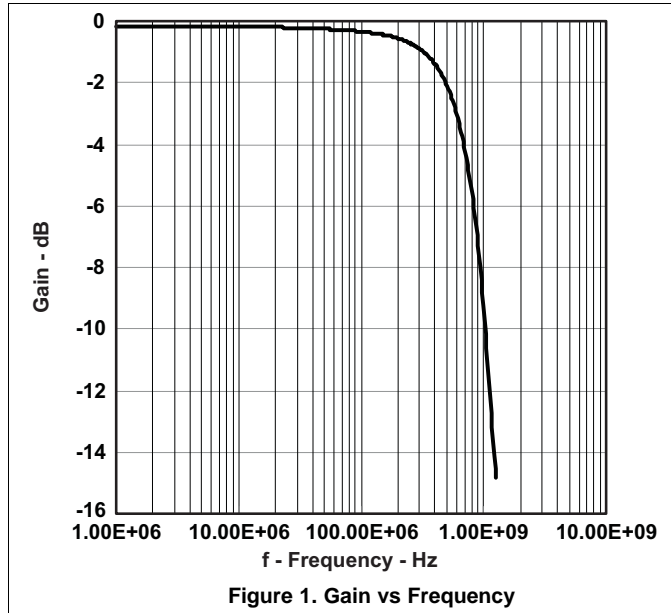

## 7 Parameter Measurement Information

### 7.1 Enable and Disable Times

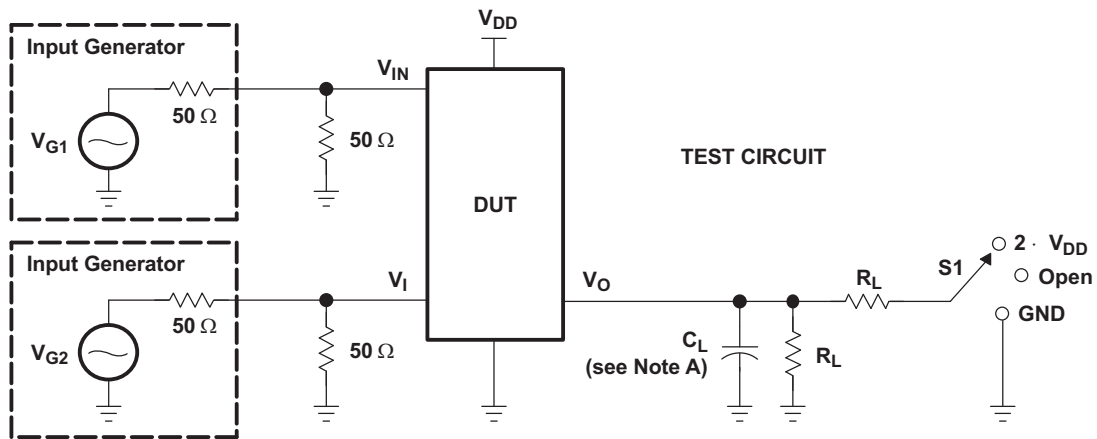

| TEST                                 | V <sub>DD</sub> | S1                  | R <sub>L</sub> | V <sub>in</sub> | C <sub>L</sub> | V <sub>Δ</sub> |
|--------------------------------------|-----------------|---------------------|----------------|-----------------|----------------|----------------|
| t <sub>P LZ</sub> /t <sub>P ZL</sub> | 3.3 V           | 2 · V <sub>DD</sub> | 200 Ω          | GND             | 10 pF          | 0.3 V          |
| t <sub>P HZ</sub> /t <sub>P ZH</sub> | 3.3 V           | GND                 | 200 Ω          | V <sub>DD</sub> | 10 pF          | 0.3 V          |

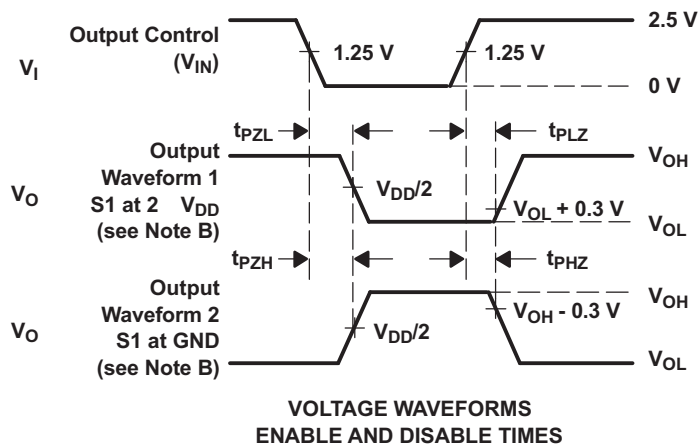

- NOTES:
- A. C<sub>L</sub> includes probe and jig capacitance.
  - B. Waveform 1 is for an output with internal conditions such that the output is low except when disabled by the output control. Waveform 2 is for an output with internal conditions such that the output is high, except when disabled by the output control.
  - C. All input pulses are supplied by generators having the following characteristics: PRR ≤ 10 MHz, Z<sub>O</sub> = 50 Ω, t<sub>r</sub> ≤ 2.5 ns, t<sub>f</sub> ≤ 2.5 ns.
  - D. The outputs are measured one at a time, with one transition per measurement.
  - E. t<sub>P LZ</sub> and t<sub>P HZ</sub> are the same as t<sub>d is</sub>.
  - F. t<sub>P ZL</sub> and t<sub>P ZH</sub> are the same as t<sub>en</sub>.

Figure 5. Test Circuit and Voltage Waveforms

## 7.2 Skew

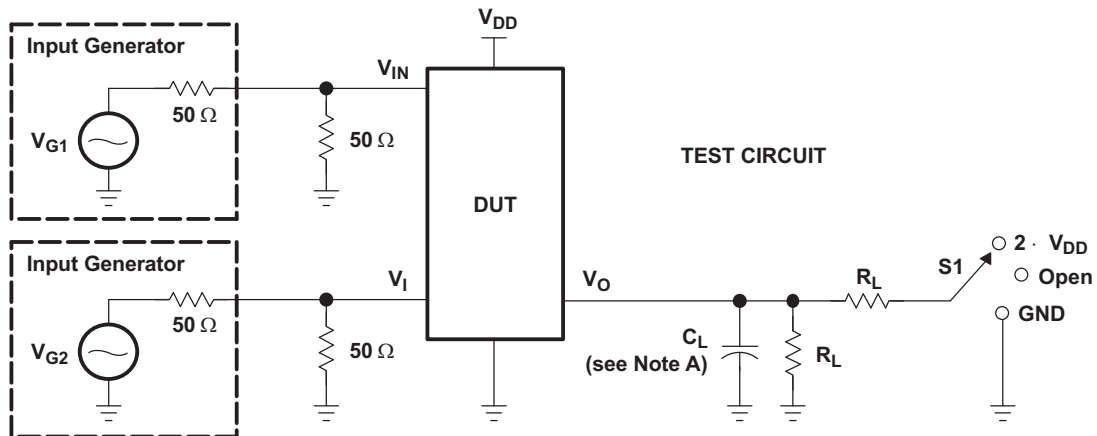

| TEST               | V <sub>DD</sub> | S1   | R <sub>L</sub> | V <sub>in</sub>        | C <sub>L</sub> |
|--------------------|-----------------|------|----------------|------------------------|----------------|
| t <sub>sk(o)</sub> | 3.3 V ± 0.3 V   | Open | 200 Ω          | V <sub>DD</sub> or GND | 10 pF          |
| t <sub>sk(p)</sub> | 3.3 V ± 0.3 V   | Open | 200 Ω          | V <sub>DD</sub> or GND | 10 pF          |

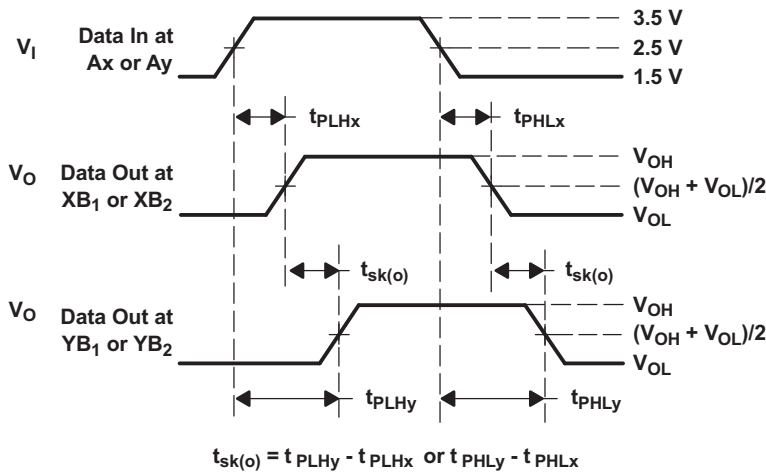

**VOLTAGE WAVEFORMS  
OUTPUT SKEW (t<sub>sk(o)</sub>)**

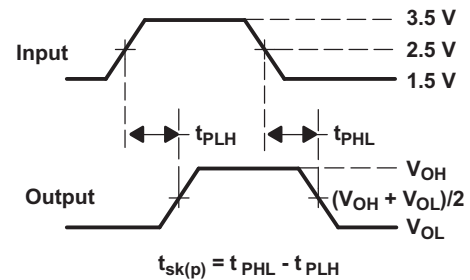

**VOLTAGE WAVEFORMS  
PULSE SKEW [t<sub>sk(p)</sub>]**

- NOTES: A. C<sub>L</sub> includes probe and jig capacitance.  
 B. Waveform 1 is for an output with internal conditions such that the output is low except when disabled by the output control. Waveform 2 is for an output with internal conditions such that the output is high, except when disabled by the output control.  
 C. All input pulses are supplied by generators having the following characteristics: PRR ≤ 10 MHz, Z<sub>O</sub> = 50 Ω, t<sub>r</sub> ≤ 2.5 ns, t<sub>f</sub> ≤ 2.5 ns.  
 D. The outputs are measured one at a time, with one transition per measurement.

**Figure 6. Test Circuit and Voltage Waveforms**

Skew (continued)

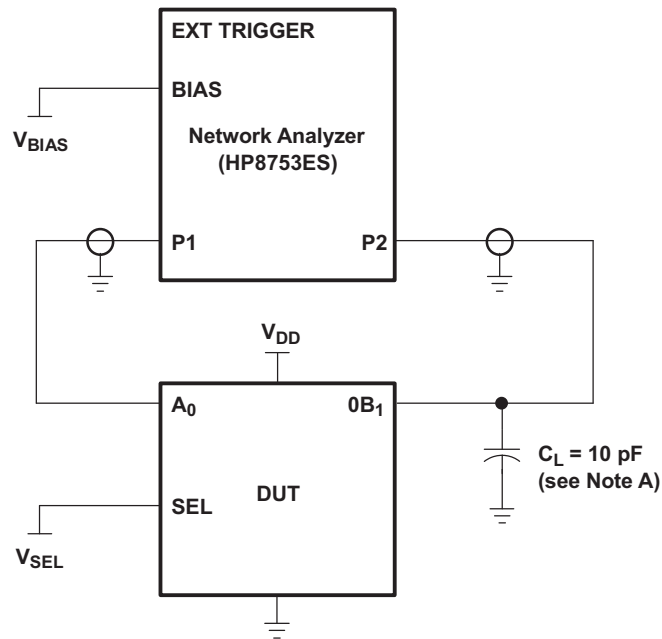

A.  $C_L$  includes probe and jig capacitance.

Figure 7. Test Circuit for Frequency Response (BW)

Frequency response is measured at the output of the ON channel. For example, when  $V_{SEL} = 0$  and  $A_0$  is the input, the output is measured at  $0B_1$ . All unused analog I/O ports are left open.

7.3 HP8753ES Setup

Average = 4  
 RBW = 3 kHz  
 $V_{BIAS} = 0.35$  V  
 ST = 2 s  
 P1 = 0 dBm

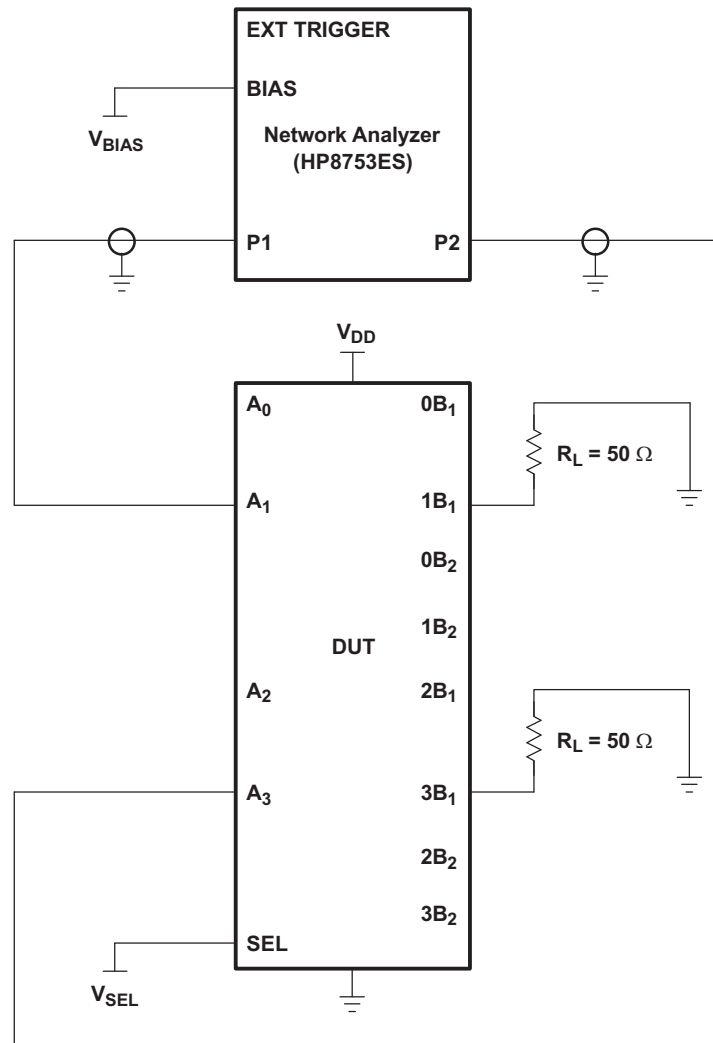
**HP8753ES Setup (continued)**

- A.  $C_L$  includes probe and jig capacitance.
- B. A 50- $\Omega$  termination resistor is needed to match the loading of the network analyzer.

**Figure 8. Test Circuit for Crosstalk ( $X_{TALK}$ )**

Crosstalk is measured at the output of the nonadjacent ON channel. For example, when  $V_{SEL} = 0$  and  $A_1$  is the input, the output is measured at  $A_3$ . All unused analog input (A) ports are connected to GND, and output (B) ports are left open.

**7.4 HP8753ES Setup**

Average = 4  
 RBW = 3 kHz  
 $V_{BIAS} = 0.35$  V  
 ST = 2 s  
 P1 = 0 dBm

HP8753ES Setup (continued)

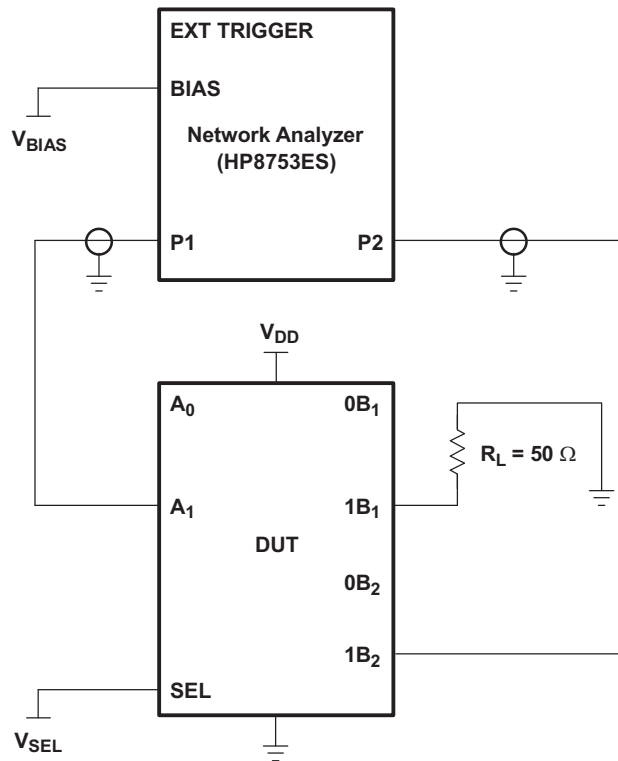

- A.  $C_L$  includes probe and jig capacitance.
- B. A 50- $\Omega$  termination resistor is needed to match the loading of the network analyzer.

**Figure 9. Test Circuit for OFF Isolation ( $O_{IRR}$ )**

OFF isolation is measured at the output of the OFF channel. For example, when  $V_{SEL} = GND$  and  $A_1$  is the input, the output is measured at  $1B_2$ . All unused analog input (A) ports are connected to ground, and output (B) ports are left open.

**7.5 HP8753ES Setup**

Average = 4  
 RBW = 3 kHz  
 $V_{BIAS} = 0.35\text{ V}$   
 ST = 2 s  
 P1 = 0 dBm

## 8 Detailed Description

### 8.1 Overview

The TS3L501E is a 8-channel SPDT analog switch or 16-bit to 8-bit multiplexer/demultiplexer LAN switch with a single select (SEL) input and Power Down Mode input. The device provides additional I/Os for switching status indicating LED signals and includes high ESD protection. SEL input controls the data path of the multiplexer/demultiplexer. Power Down input can put the device into the standby mode for minimizing current consumption per mode selection.

The device provides a low and flat ON-state resistance ( $r_{on}$ ) and an excellent ON-state resistance match. Low input/output capacitance, high bandwidth, low skew, and low crosstalk among channels make this device suitable for various LAN applications, such as 10/100/1000 Base-T. This device can be used to replace mechanical relays in LAN applications. It also can be used to route signals from a 10/100 Base-T Ethernet transceiver to the RJ-45 LAN connectors in laptops or in docking stations.

### 8.2 Functional Block Diagram

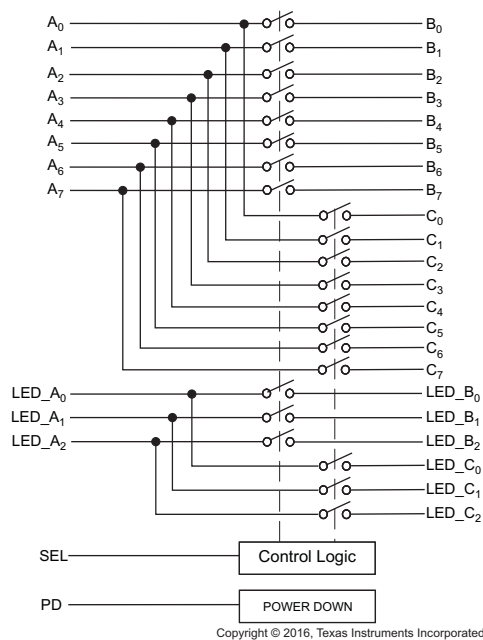

Figure 10. Logic Diagram (Positive Logic)

### 8.3 Feature Description

The TS3L501E device switches and pin out are optimized for ethernet application but the device can be used for many applications where a multi-channel, 1:2 SPDT, high bandwidth switch is needed.

### 8.4 Device Functional Modes

The TS3L501E supports a power down mode which reduces the current consumption of the device and places all the signal paths in a high impedance state. To place the TS3L501E in power down mode, set the PD pin with a logic high voltage as seen in [Table 1](#).

Table 1. Function Table

| PD | SEL | FUNCTION                                  |
|----|-----|---|
| L  | L   | $A_n$ to $B_n$ , LED_ $A_n$ to LED_ $B_n$ |
| L  | H   | $A_n$ to $C_n$ , LED_ $A_n$ to LED_ $C_n$ |
| H  | X   | Hi-Z                                      |

## 9 Application and Implementation

### NOTE

Information in the following applications sections is not part of the TI component specification, and TI does not warrant its accuracy or completeness. TI's customers are responsible for determining suitability of components for their purposes. Customers should validate and test their design implementation to confirm system functionality.

### 9.1 Application Information

There are many Local Area Network (LAN) applications in which the ethernet hubs or controllers have a limited number of I/Os or need to route signals from a single ethernet PHY to multiple ethernet jacks. The TS3L501E solution can effectively expand the limited I/Os by switching between multiple ethernet jacks to interface them to a single ethernet PHY.

The LED\_A<sub>n</sub>, LED\_B<sub>n</sub>, and LED\_C<sub>n</sub> pins are rated the same as the other signal path pins so you may use these pins as extra data paths if needed.

### 9.2 Typical Application

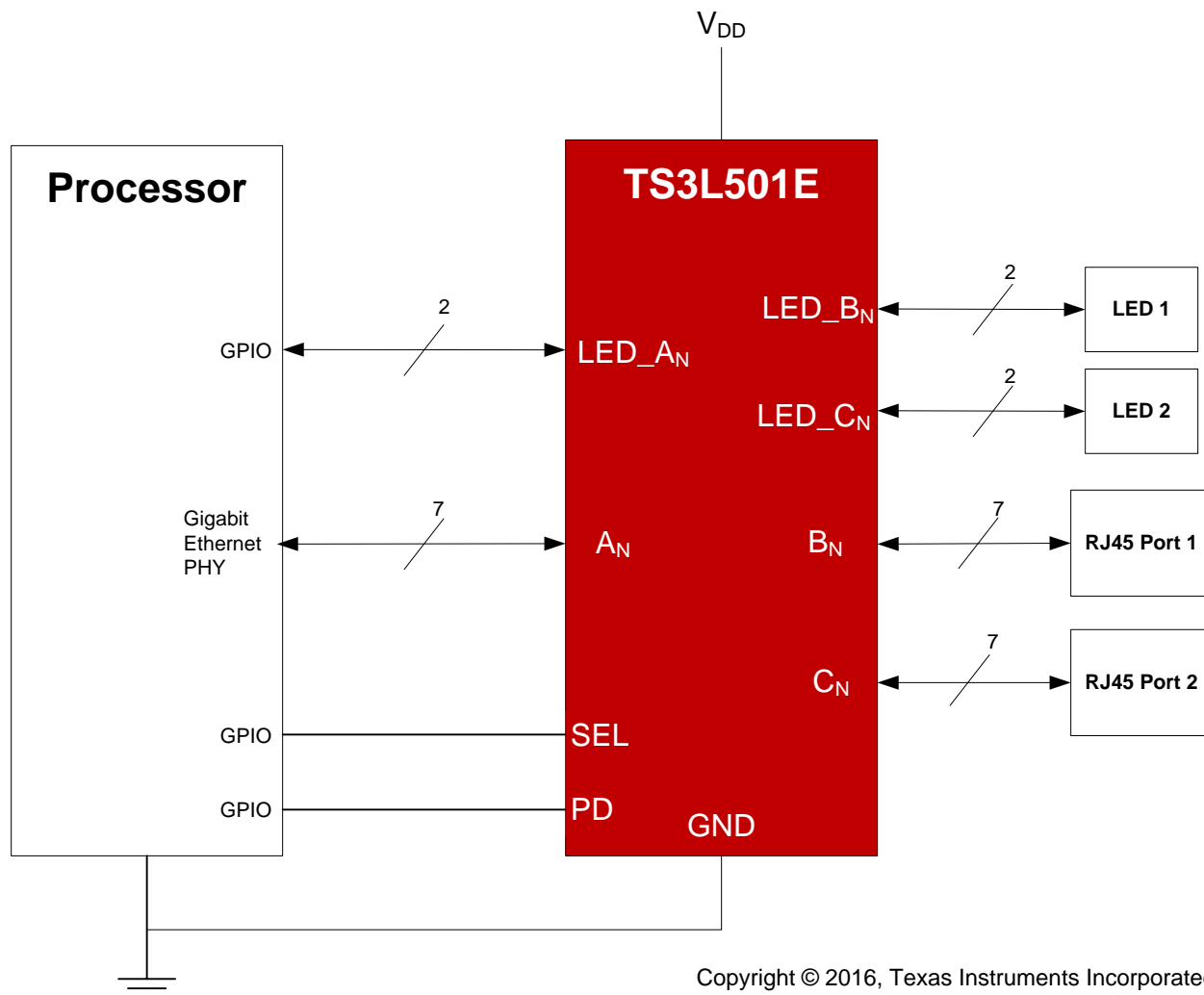

Copyright © 2016, Texas Instruments Incorporated

Figure 11. Typical Application Schematic

## Typical Application (continued)

### 9.2.1 Design Requirements

Ensure that all of the signals passing through the switch are within the recommended operating ranges. To ensure proper performance, see [Recommended Operating Conditions](#).

### 9.2.2 Detailed Design Procedure

The TS3L501E can be properly operated without any external components.

TI recommends that the digital control pins SEL and PD be pulled up to VCC or down to GND to avoid undesired switch positions that could result from the floating pin.

Connect the exposed thermal pad to ground.

### 9.2.3 Application Curve

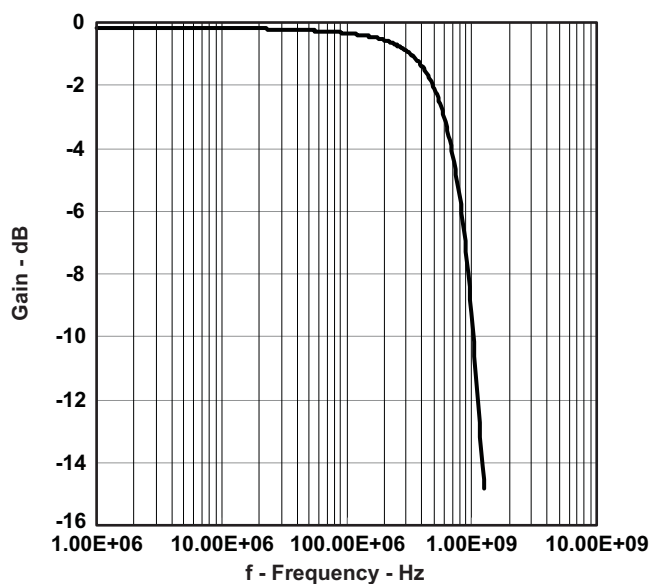

Figure 12. Gain vs Frequency

## 10 Power Supply Recommendations

Power to the device is supplied through the  $V_{DD}$  pins. TI recommends placing a bypass capacitor as close to the supply pin (VCC) as possible to help smooth out lower frequency noise to provide better load regulation across the frequency spectrum.

All  $V_{DD}$  pins are internally connected. One PCB layout option is to connect one of the  $V_{DD}$  to the power supply and leave the other  $V_{DD}$  pins open.

Supply the TS3L501E  $V_{DD}$  pins with the recommended voltage before applying a signal voltage to the I/O signal paths to avoid violating the recommended operating condition I/O voltage  $0-V_{DD}$ .

## 11 Layout

### 11.1 Layout Guidelines

- TI recommends keeping the high-speed signals as short as possible.
- Each via introduces discontinuities in the transmission line of the signal and increases the chance of picking up interference from the other layers of the board. Be careful when designing test points on twisted pair lines; through-hole pins are not recommended.
- When it becomes necessary to turn  $90^\circ$ , use two  $45^\circ$  turns or an arc instead of making a single  $90^\circ$  turn. This reduces reflections on the signal traces by minimizing impedance discontinuities.
- Do not route traces under or near crystals, oscillators, clock signal generators, switching regulators, mounting holes, magnetic devices or ICs that use or duplicate clock signals.
- Avoid stubs on the high-speed signals because they cause signal reflections. If a stub is unavoidable, then the stub must be less than 200 mm.
- Route all high-speed signal traces over continuous GND planes, with no interruptions. Avoid crossing over anti-etch, commonly found with plane splits.
- Due to high-frequency signals, a printed-circuit board with at least four layers is recommended; two signal layers separated by a ground and a power layer as shown in [Figure 13](#).
- The majority of signal traces must run on a single layer, preferably Signal 1. Immediately next to this layer should be the GND plane, which is solid with no cuts. Avoid running signal traces across a split in the ground or power plane. When running across split planes is unavoidable, sufficient decoupling must be used. Minimizing the number of signal vias reduces EMI by reducing inductance at high frequencies.

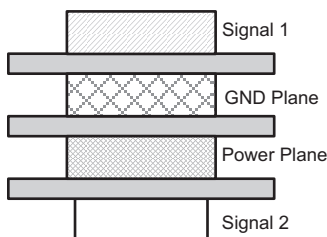

**Figure 13. Four-Layer Board Stackup**

## 11.2 Layout Example

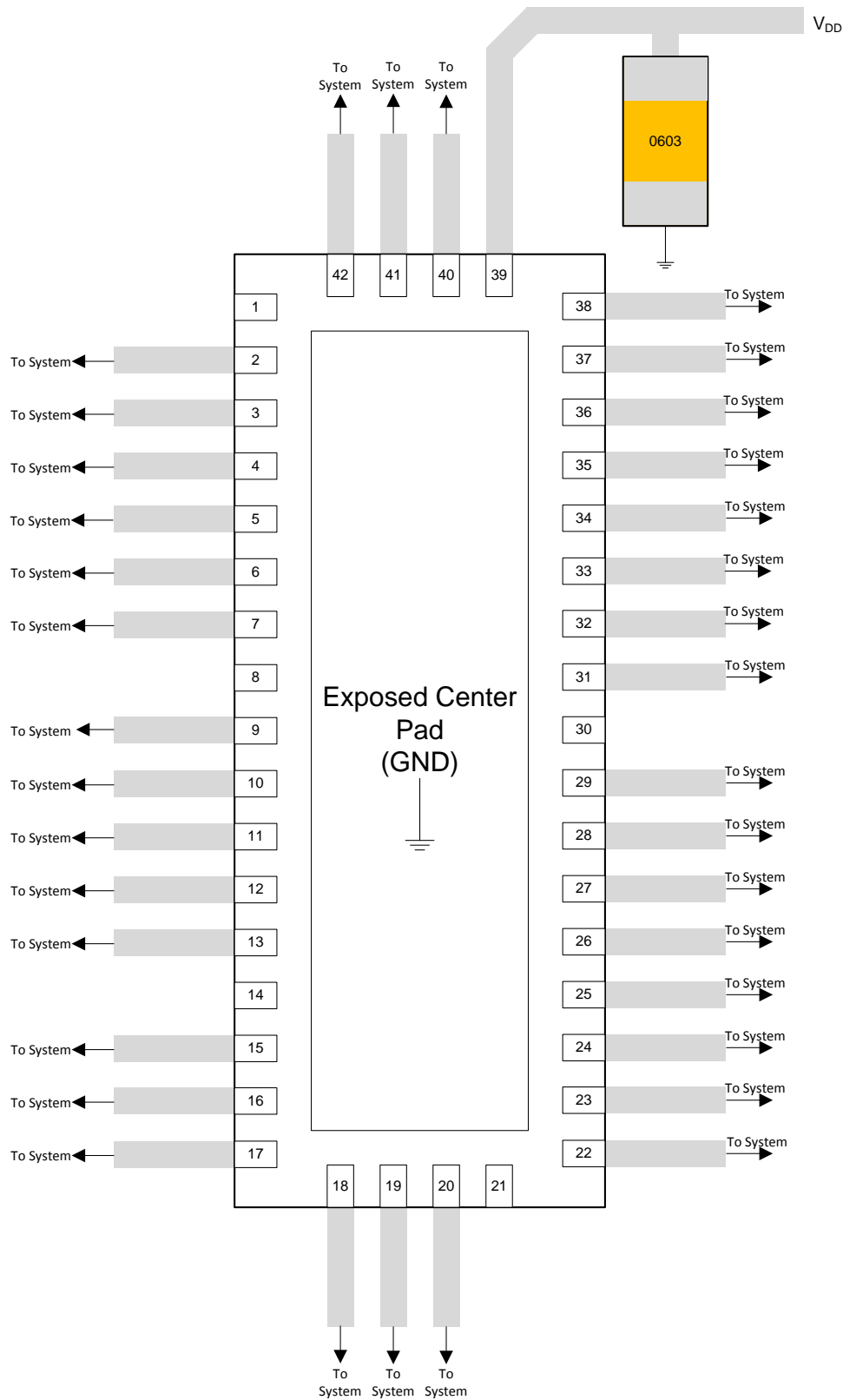

Figure 14. Layout Example

## 12 Device and Documentation Support

### 12.1 Documentation Support

#### 12.1.1 Related Documentation

For related documentation, see the following:

*Implications of Slow or Floating CMOS Inputs*, [SCBA004](#)

### 12.2 Receiving Notification of Documentation Updates

To receive notification of documentation updates, navigate to the device product folder on ti.com. In the upper right corner, click on *Alert me* to register and receive a weekly digest of any product information that has changed. For change details, review the revision history included in any revised document.

### 12.3 Community Resources

The following links connect to TI community resources. Linked contents are provided "AS IS" by the respective contributors. They do not constitute TI specifications and do not necessarily reflect TI's views; see TI's [Terms of Use](#).

**TI E2E™ Online Community** *TI's Engineer-to-Engineer (E2E) Community*. Created to foster collaboration among engineers. At e2e.ti.com, you can ask questions, share knowledge, explore ideas and help solve problems with fellow engineers.

**Design Support** *TI's Design Support* Quickly find helpful E2E forums along with design support tools and contact information for technical support.

### 12.4 Trademarks

E2E is a trademark of Texas Instruments.

All other trademarks are the property of their respective owners.

### 12.5 Electrostatic Discharge Caution



This integrated circuit can be damaged by ESD. Texas Instruments recommends that all integrated circuits be handled with appropriate precautions. Failure to observe proper handling and installation procedures can cause damage.

ESD damage can range from subtle performance degradation to complete device failure. Precision integrated circuits may be more susceptible to damage because very small parametric changes could cause the device not to meet its published specifications.

### 12.6 Glossary

[SLYZ022](#) — *TI Glossary*.

This glossary lists and explains terms, acronyms, and definitions.

## 13 Mechanical, Packaging, and Orderable Information

The following pages include mechanical, packaging, and orderable information. This information is the most current data available for the designated devices. This data is subject to change without notice and revision of this document. For browser-based versions of this data sheet, refer to the left-hand navigation.

**PACKAGING INFORMATION**

| Orderable Device | Status<br>(1) | Package Type | Package<br>Drawing | Pins | Package<br>Qty | Eco Plan<br>(2)            | Lead/Ball Finish<br>(6) | MSL Peak Temp<br>(3) | Op Temp (°C) | Device Marking<br>(4/5) | Samples                 |
|------------------|---------------|--------------|--------------------|------|----------------|----------------------------|-------------------------|----------------------|--------------|-------------------------|-------------------------|
| TS3L501ERUAR     | ACTIVE        | WQFN         | RUA                | 42   | 3000           | Green (RoHS<br>& no Sb/Br) | CU NIPDAU               | Level-2-260C-1 YEAR  | -40 to 85    | TK501E                  | <a href="#">Samples</a> |

(1) The marketing status values are defined as follows:

**ACTIVE:** Product device recommended for new designs.

**LIFEBUY:** TI has announced that the device will be discontinued, and a lifetime-buy period is in effect.

**NRND:** Not recommended for new designs. Device is in production to support existing customers, but TI does not recommend using this part in a new design.

**PREVIEW:** Device has been announced but is not in production. Samples may or may not be available.

**OBSOLETE:** TI has discontinued the production of the device.

(2) **RoHS:** TI defines "RoHS" to mean semiconductor products that are compliant with the current EU RoHS requirements for all 10 RoHS substances, including the requirement that RoHS substance do not exceed 0.1% by weight in homogeneous materials. Where designed to be soldered at high temperatures, "RoHS" products are suitable for use in specified lead-free processes. TI may reference these types of products as "Pb-Free".

**RoHS Exempt:** TI defines "RoHS Exempt" to mean products that contain lead but are compliant with EU RoHS pursuant to a specific EU RoHS exemption.

**Green:** TI defines "Green" to mean the content of Chlorine (Cl) and Bromine (Br) based flame retardants meet JS709B low halogen requirements of <=1000ppm threshold. Antimony trioxide based flame retardants must also meet the <=1000ppm threshold requirement.

(3) MSL, Peak Temp. - The Moisture Sensitivity Level rating according to the JEDEC industry standard classifications, and peak solder temperature.

(4) There may be additional marking, which relates to the logo, the lot trace code information, or the environmental category on the device.

(5) Multiple Device Markings will be inside parentheses. Only one Device Marking contained in parentheses and separated by a "~" will appear on a device. If a line is indented then it is a continuation of the previous line and the two combined represent the entire Device Marking for that device.

(6) Lead/Ball Finish - Orderable Devices may have multiple material finish options. Finish options are separated by a vertical ruled line. Lead/Ball Finish values may wrap to two lines if the finish value exceeds the maximum column width.

**Important Information and Disclaimer:** The information provided on this page represents TI's knowledge and belief as of the date that it is provided. TI bases its knowledge and belief on information provided by third parties, and makes no representation or warranty as to the accuracy of such information. Efforts are underway to better integrate information from third parties. TI has taken and continues to take reasonable steps to provide representative and accurate information but may not have conducted destructive testing or chemical analysis on incoming materials and chemicals. TI and TI suppliers consider certain information to be proprietary, and thus CAS numbers and other limited information may not be available for release.

In no event shall TI's liability arising out of such information exceed the total purchase price of the TI part(s) at issue in this document sold by TI to Customer on an annual basis.

## TAPE AND REEL INFORMATION



### QUADRANT ASSIGNMENTS FOR PIN 1 ORIENTATION IN TAPE

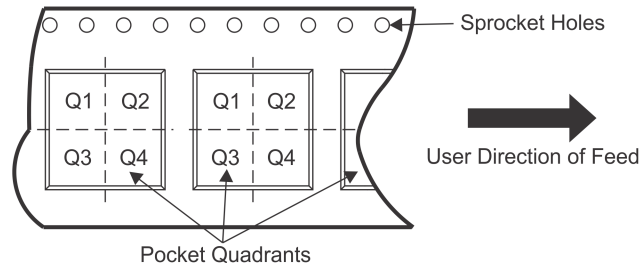

\*All dimensions are nominal

| Device       | Package Type | Package Drawing | Pins | SPQ  | Reel Diameter (mm) | Reel Width W1 (mm) | A0 (mm) | B0 (mm) | K0 (mm) | P1 (mm) | W (mm) | Pin1 Quadrant |
|--------------|--------------|-----------------|------|------|--------------------|--------------------|---------|---------|---------|---------|--------|---------------|
| TS3L501ERUAR | WQFN         | RUA             | 42   | 3000 | 330.0              | 16.4               | 3.8     | 9.3     | 1.0     | 8.0     | 16.0   | Q1            |

TAPE AND REEL BOX DIMENSIONS



\*All dimensions are nominal

| Device       | Package Type | Package Drawing | Pins | SPQ  | Length (mm) | Width (mm) | Height (mm) |
|--------------|--------------|-----------------|------|------|-------------|------------|-------------|
| TS3L501ERUAR | WQFN         | RUA             | 42   | 3000 | 367.0       | 367.0      | 38.0        |

# MECHANICAL DATA

RUA (R-PWQFN-N42)

PLASTIC QUAD FLATPACK NO-LEAD

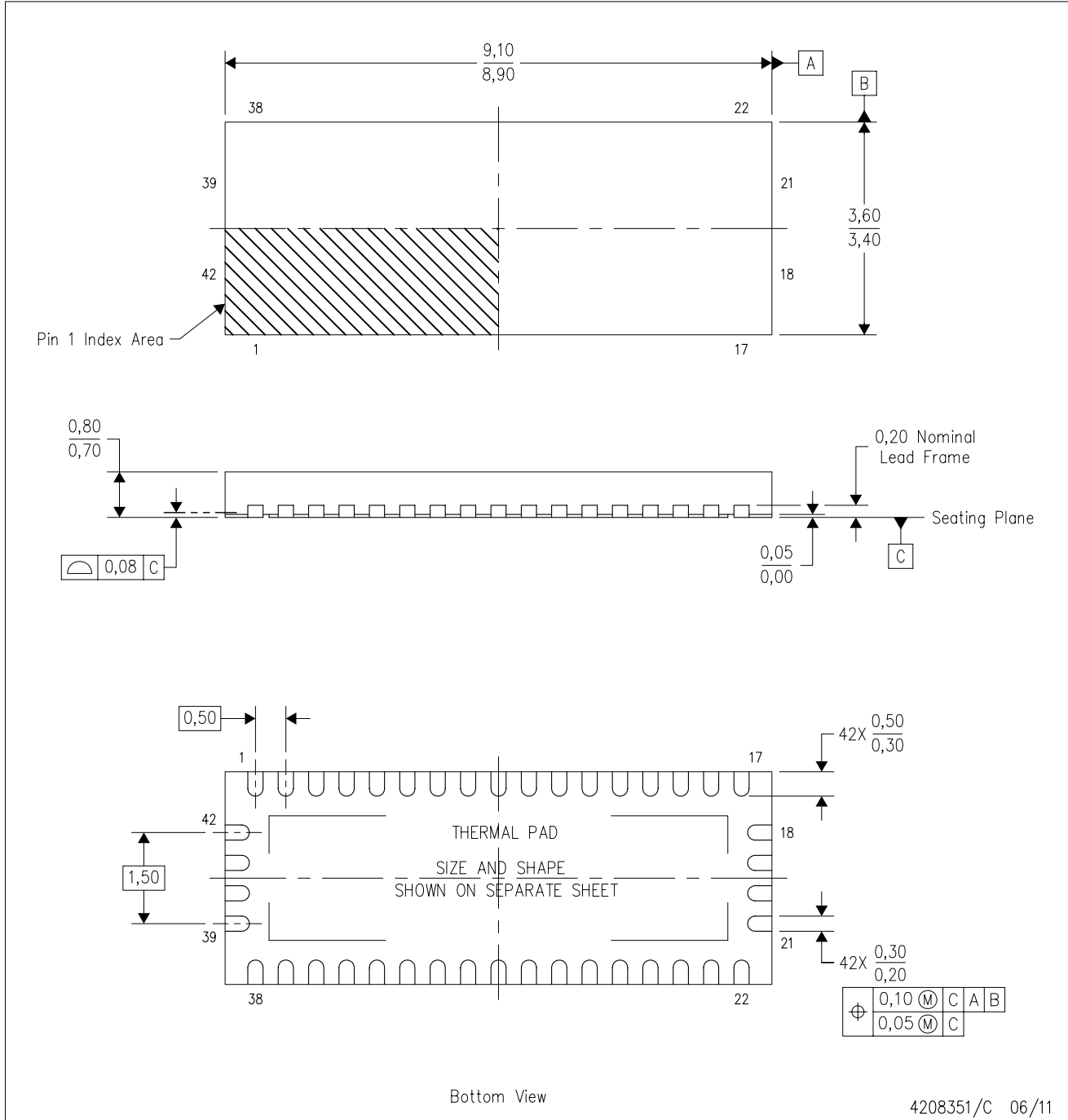

- NOTES:
- All linear dimensions are in millimeters. Dimensioning and tolerancing per ASME Y14.5M-1994.
  - This drawing is subject to change without notice.
  - QFN (Quad Flatpack No-Lead) package configuration.
  - The package thermal pad must be soldered to the board for thermal and mechanical performance.
  - See the additional figure in the Product Data Sheet for details regarding the exposed thermal pad features and dimensions.

## THERMAL PAD MECHANICAL DATA

RUA (R-PWQFN-N42)

PLASTIC QUAD FLATPACK NO-LEAD

### THERMAL INFORMATION

This package incorporates an exposed thermal pad that is designed to be attached directly to an external heatsink. The thermal pad must be soldered directly to the printed circuit board (PCB). After soldering, the PCB can be used as a heatsink. In addition, through the use of thermal vias, the thermal pad can be attached directly to the appropriate copper plane shown in the electrical schematic for the device, or alternatively, can be attached to a special heatsink structure designed into the PCB. This design optimizes the heat transfer from the integrated circuit (IC).

For information on the Quad Flatpack No-Lead (QFN) package and its advantages, refer to Application Report, QFN/SON PCB Attachment, Texas Instruments Literature No. SLUA271. This document is available at [www.ti.com](http://www.ti.com).

The exposed thermal pad dimensions for this package are shown in the following illustration.

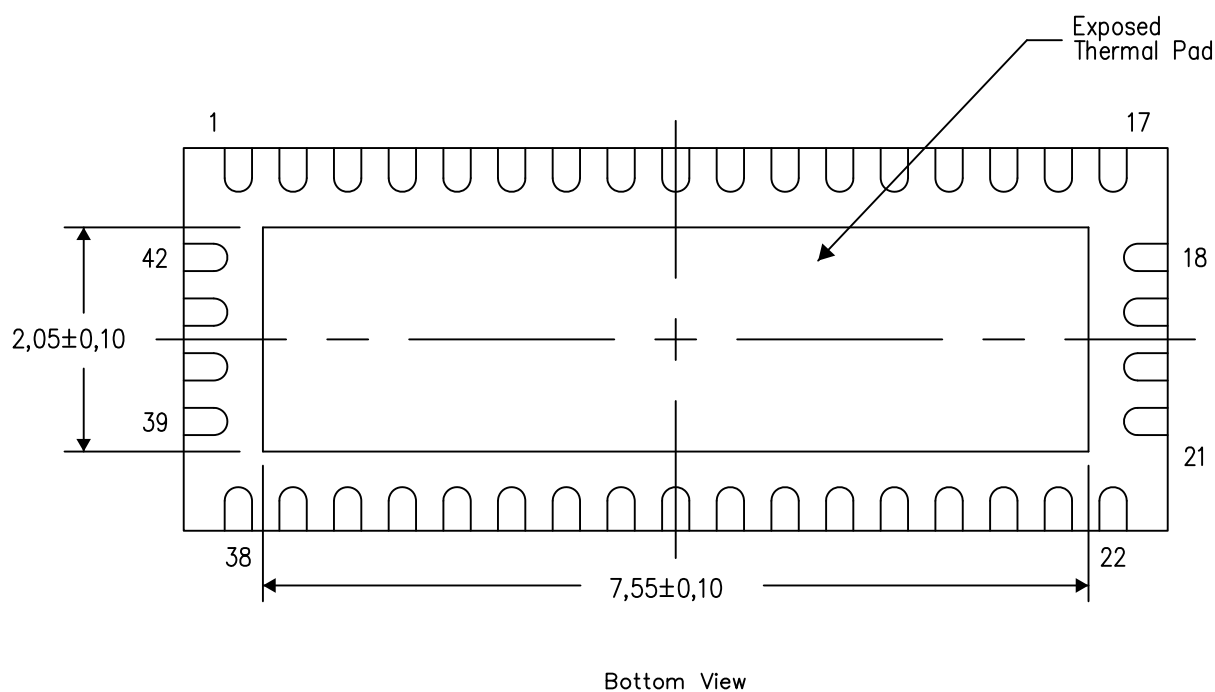

Exposed Thermal Pad Dimensions

4208352/E 01/13

NOTE: All linear dimensions are in millimeters

RUA (R-PWQFN-N42)

PLASTIC QUAD FLATPACK NO-LEAD

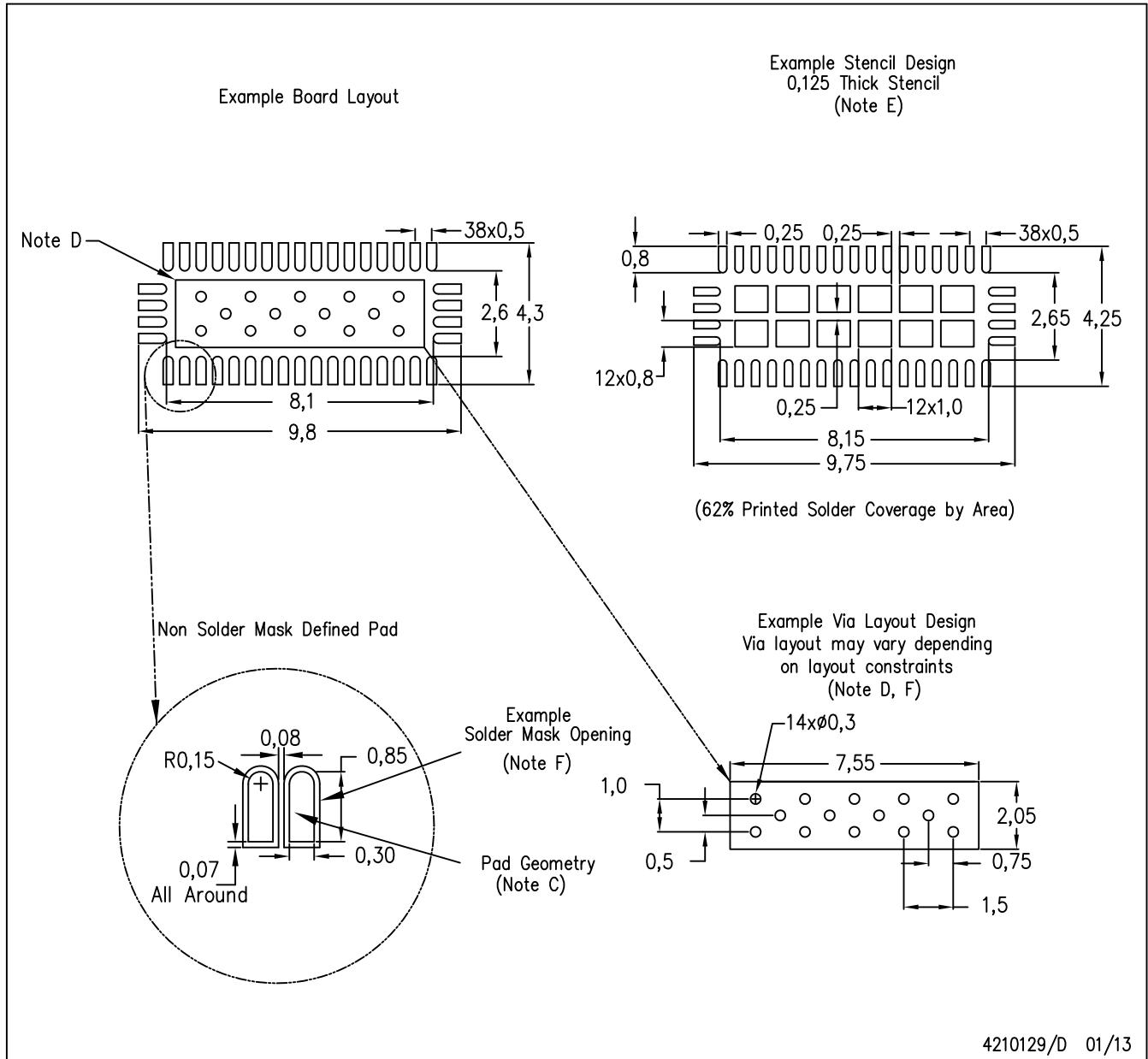

- NOTES:
- A. All linear dimensions are in millimeters.
  - B. This drawing is subject to change without notice.
  - C. Publication IPC-7351 is recommended for alternate designs.
  - D. This package is designed to be soldered to a thermal pad on the board. Refer to Application Note, Quad Flat-Pack Packages, Texas Instruments Literature No. SLUA271, and also the Product Data Sheets for specific thermal information, via requirements, and recommended board layout. These documents are available at [www.ti.com](http://www.ti.com) <<http://www.ti.com>>.
  - E. Laser cutting apertures with trapezoidal walls and also rounding corners will offer better paste release. Customers should contact their board assembly site for stencil design recommendations. Refer to IPC 7525 for stencil design considerations.
  - F. Customers should contact their board fabrication site for recommended solder mask tolerances and via tenting recommendations for vias placed in the thermal pad.

## IMPORTANT NOTICE AND DISCLAIMER

TI PROVIDES TECHNICAL AND RELIABILITY DATA (INCLUDING DATASHEETS), DESIGN RESOURCES (INCLUDING REFERENCE DESIGNS), APPLICATION OR OTHER DESIGN ADVICE, WEB TOOLS, SAFETY INFORMATION, AND OTHER RESOURCES "AS IS" AND WITH ALL FAULTS, AND DISCLAIMS ALL WARRANTIES, EXPRESS AND IMPLIED, INCLUDING WITHOUT LIMITATION ANY IMPLIED WARRANTIES OF MERCHANTABILITY, FITNESS FOR A PARTICULAR PURPOSE OR NON-INFRINGEMENT OF THIRD PARTY INTELLECTUAL PROPERTY RIGHTS.

These resources are intended for skilled developers designing with TI products. You are solely responsible for (1) selecting the appropriate TI products for your application, (2) designing, validating and testing your application, and (3) ensuring your application meets applicable standards, and any other safety, security, or other requirements. These resources are subject to change without notice. TI grants you permission to use these resources only for development of an application that uses the TI products described in the resource. Other reproduction and display of these resources is prohibited. No license is granted to any other TI intellectual property right or to any third party intellectual property right. TI disclaims responsibility for, and you will fully indemnify TI and its representatives against, any claims, damages, costs, losses, and liabilities arising out of your use of these resources.

TI's products are provided subject to TI's Terms of Sale ([www.ti.com/legal/termsofsale.html](http://www.ti.com/legal/termsofsale.html)) or other applicable terms available either on [ti.com](http://ti.com) or provided in conjunction with such TI products. TI's provision of these resources does not expand or otherwise alter TI's applicable warranties or warranty disclaimers for TI products.

Mailing Address: Texas Instruments, Post Office Box 655303, Dallas, Texas 75265  
Copyright © 2019, Texas Instruments Incorporated

## Looking for pricing, stock, or lifecycle information?

Click below to explore more details on WIN SOURCE:

 [View TS3L501ERUAR on WIN SOURCE](#)

 [Texas Instruments](#) Information

## Optimize Your Supply Chain with WIN SOURCE Solutions

-  Global Sourcing Solution
-  Obsolete Management
-  Cost Control Management
-  Shortage Management
-  Alternative Solution
-  Excess Inventory Management