



THE DATASHEET OF TS3L301DGVR



FEATURES

- Wide Bandwidth (BW = 900 MHz Typ)
- Low Crosstalk ($X_{TALK} = -41$ dB Typ)
- Low Bit-to-Bit Skew [$t_{sk(o)} = 0.2$ ns Max]
- Low and Flat ON-State Resistance ($r_{on} = 4 \Omega$ Typ, $r_{on(flat)} = 0.7 \Omega$ Typ)
- Low Input/Output Capacitance ($C_{ON} = 10$ pF Typ)
- Rail-to-Rail Switching on Data I/O Ports (0 to 5 V)
- V_{DD} Operating Range From 3 V to 3.6 V
- I_{off} Supports Partial Power-Down-Mode Operation
- Latch-Up Performance Exceeds 100 mA Per JESD 78, Class II
- ESD Performance Tested Per JESD 22
 - 2000-V Human-Body Model (A114-B, Class II)
 - 1000-V Charged-Device Model (C101)
- Suitable for 10-/100-/1000-Mbit Ethernet Signaling

APPLICATIONS

- 10/100/1000 Base-T Signal Switching
- Differential (LVDS, LVPECL) Signal Switching
- Digital Video Signal Routing
- Notebook Docking Signal Routing
- Hub and Router Signal Switching

DESCRIPTION/ORDERING INFORMATION

The TS3L301 is a 16-bit to 8-bit multiplexer/demultiplexer local area network (LAN) switch with a single select (SEL) input. The SEL input controls the data path of the multiplexer/demultiplexer.

The device provides a low and flat ON-state resistance (r_{on}) and an excellent ON-state resistance match. Low input/output capacitance, high-bandwidth, low skew, and low crosstalk among channels make this device suitable for various LAN applications, such as 10/100/1000 Base-T.

ORDERING INFORMATION

T_A	PACKAGE ⁽¹⁾		ORDERABLE PART NUMBER	TOP-SIDE MARKING
-40°C to 85°C	TSSOP – DGG	Tape and reel	TS3L301DGGR	TS3L301
	TVSOP – DGV	Tape and reel	TS3L301DGVR	TK301

(1) Package drawings, standard packing quantities, thermal data, symbolization, and PCB design guidelines are available at www.ti.com/sc/package.

DGG OR DGV PACKAGE
(TOP VIEW)

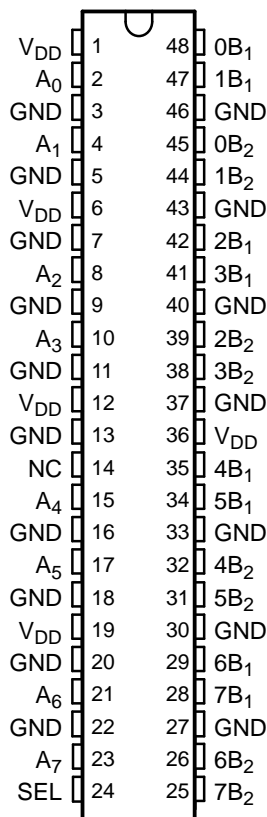

NC – No internal connection



Please be aware that an important notice concerning availability, standard warranty, and use in critical applications of Texas Instruments semiconductor products and disclaimers thereto appears at the end of this data sheet.

TS3L301
16-BIT TO 8-BIT SPDT GIGABIT LAN SWITCH
WITH LOW AND FLAT ON-STATE RESISTANCE

SCDS178C–NOVEMBER 2004–REVISED APRIL 2006

FUNCTION TABLE

INPUT SEL	INPUT/OUTPUT A_n	FUNCTION
L	nB_1	$A_n = nB_1$
H	nB_2	$A_n = nB_2$

PIN DESCRIPTION

NAME	DESCRIPTION
A_n	Data I/Os
nB_m	Data I/Os
SEL	Select input

LOGIC DIAGRAM (POSITIVE LOGIC)

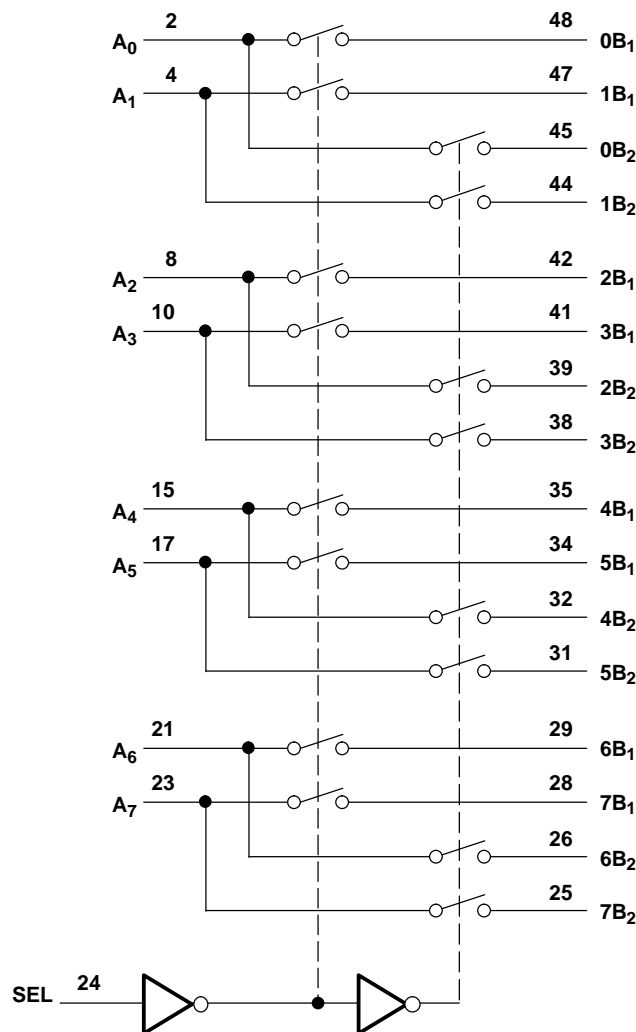

Absolute Maximum Ratings⁽¹⁾

over operating free-air temperature range (unless otherwise noted)

		MIN	MAX	UNIT
V _{DD}	Supply voltage range	-0.5	4.6	V
V _{IN}	Control input voltage range ⁽²⁾⁽³⁾	-0.5	7	V
V _{I/O}	Switch I/O voltage range ⁽²⁾⁽³⁾⁽⁴⁾	-0.5	7	V
I _{IK}	Control input clamp current	V _{IN} < 0		-50 mA
I _{I/OK}	I/O port clamp current	V _{I/O} < 0		-50 mA
I _{I/O}	ON-state switch current ⁽⁵⁾			±128 mA
Continuous current through V _{DD} or GND				±100 mA
θ _{JA}	Package thermal impedance ⁽⁶⁾	DGG package		70 °C/W
		DGV package		58 °C/W
T _{stg}	Storage temperature range	-65	150	°C

(1) Stresses beyond those listed under "absolute maximum ratings" may cause permanent damage to the device. These are stress ratings only, and functional operation of the device at these or any other conditions beyond those indicated under "recommended operating conditions" is not implied. Exposure to absolute-maximum-rated conditions for extended periods may affect device reliability.

(2) All voltages are with respect to ground, unless otherwise specified.

(3) The input and output voltage ratings may be exceeded if the input and output clamp-current ratings are observed.

(4) V_I and V_O are used to denote specific conditions for V_{I/O}.

(5) I_I and I_O are used to denote specific conditions for I_{I/O}.

(6) The package thermal impedance is calculated in accordance with JESD 51-7.

Recommended Operating Conditions⁽¹⁾

		MIN	MAX	UNIT
V _{DD}	Supply voltage	3	3.6	V
V _{IH}	High-level control input voltage (SEL)	2	5.5	V
V _{IL}	Low-level control input voltage (SEL)	0	0.8	V
V _{I/O}	Input/output voltage	0	5.5	V
T _A	Operating free-air temperature	-40	85	°C

(1) All unused control inputs of the device must be held at V_{DD} or GND to ensure proper device operation. Refer to the TI application report, *Implications of Slow or Floating CMOS Inputs*, literature number SCBA004.

TS3L301

16-BIT TO 8-BIT SPDT GIGABIT LAN SWITCH WITH LOW AND FLAT ON-STATE RESISTANCE

SCDS178C–NOVEMBER 2004–REVISED APRIL 2006

Electrical Characteristics

for 1000 Base-T Ethernet switching over recommended operating free-air temperature range, $V_{DD} = 3.3 \text{ V} \pm 0.3 \text{ V}$
(unless otherwise noted)

PARAMETER		TEST CONDITIONS ⁽¹⁾		MIN	TYP ⁽²⁾	MAX	UNIT	
V_{IK}	SEL	$V_{DD} = 3.6 \text{ V}$,	$I_{IN} = -18 \text{ mA}$	-0.7	-1.2		V	
I_{IH}	SEL	$V_{DD} = 3.6 \text{ V}$,	$V_{IN} = V_{DD}$		± 1		μA	
I_{IL}	SEL	$V_{DD} = 3.6 \text{ V}$,	$V_{IN} = \text{GND}$		± 1		μA	
I_{off}		$V_{DD} = 0$,	$V_O = 0 \text{ to } 3.6 \text{ V}$,	$V_I = 0$		1	μA	
I_{DD}		$V_{DD} = 3.6 \text{ V}$,	$I_{I/O} = 0$,	Switch ON or OFF		250 600	μA	
C_{IN}	SEL	$f = 1 \text{ MHz}$,	$V_{IN} = 0$		2.5	3	pF	
C_{OFF}	B port	$V_I = 0$,	$f = 1 \text{ MHz}$,	Outputs open,	Switch OFF		3.5 4	pF
C_{ON}		$V_I = 0$,	$f = 1 \text{ MHz}$,	Outputs open,	Switch ON		10 10.9	pF
r_{on}		$V_{DD} = 3 \text{ V}$,	$1.5 \text{ V} \leq V_I \leq V_{DD}$,	$I_O = -40 \text{ mA}$		4 8	Ω	
$r_{on(Flat)}$ ⁽³⁾		$V_{DD} = 3 \text{ V}$,	$V_I = 1.5 \text{ V}$ and V_{DD} ,	$I_O = -40 \text{ mA}$		0.7	Ω	
Δr_{on} ⁽⁴⁾		$V_{DD} = 3 \text{ V}$,	$1.5 \text{ V} \leq V_I \leq V_{DD}$,	$I_O = -40 \text{ mA}$		0.2 1.2	Ω	

- (1) V_I , V_O , I_I , and I_O refer to I/O pins. V_{IN} refers to the control inputs.
(2) All typical values are at $V_{DD} = 3.3 \text{ V}$ (unless otherwise noted), $T_A = 25^\circ\text{C}$.
(3) $r_{on(Flat)}$ is the difference of r_{on} in a given channel at specified voltages.
(4) Δr_{on} is the difference of r_{on} from center (A_4 , A_5) ports to any other port.

Electrical Characteristics

for 10/100 Base-T Ethernet switching over recommended operating free-air temperature range, $V_{DD} = 3.3 \text{ V} \pm 0.3 \text{ V}$
(unless otherwise noted)

PARAMETER		TEST CONDITIONS ⁽¹⁾		MIN	TYP ⁽²⁾	MAX	UNIT	
V_{IK}	SEL	$V_{DD} = 3.6 \text{ V}$,	$I_{IN} = -18 \text{ mA}$	-0.7	-1.2		V	
I_{IH}	SEL	$V_{DD} = 3.6 \text{ V}$,	$V_{IN} = V_{DD}$		± 1		μA	
I_{IL}	SEL	$V_{DD} = 3.6 \text{ V}$,	$V_{IN} = \text{GND}$		± 1		μA	
I_{off}		$V_{DD} = 0$,	$V_O = 0 \text{ to } 3.6 \text{ V}$,	$V_I = 0$		1	μA	
I_{DD}		$V_{DD} = 3.6 \text{ V}$,	$I_{I/O} = 0$,	Switch ON or OFF		250 600	μA	
C_{IN}	SEL	$f = 1 \text{ MHz}$,	$V_{IN} = 0$		2.5	3	pF	
C_{OFF}	B port	$V_I = 0$,	$f = 1 \text{ MHz}$,	Outputs open,	Switch OFF		3.5 4	pF
C_{ON}		$V_I = 0$,	$f = 1 \text{ MHz}$,	Outputs open,	Switch ON		10 10.9	pF
r_{on}		$V_{DD} = 3 \text{ V}$,	$1.25 \text{ V} \leq V_I \leq V_{DD}$,	$I_O = -10 \text{ mA}$ to -30 mA		4 8	Ω	
$r_{on(Flat)}$ ⁽³⁾		$V_{DD} = 3 \text{ V}$,	$V_I = 1.25 \text{ V}$ and V_{DD} ,	$I_O = -10 \text{ mA}$ to -30 mA		0.7	Ω	
Δr_{on} ⁽⁴⁾		$V_{DD} = 3 \text{ V}$,	$1.25 \text{ V} \leq V_I \leq V_{DD}$,	$I_O = -10 \text{ mA}$ to -30 mA		0.2 1.2	Ω	

- (1) V_I , V_O , I_I , and I_O refer to I/O pins. V_{IN} refers to the control inputs.
(2) All typical values are at $V_{DD} = 3.3 \text{ V}$ (unless otherwise noted), $T_A = 25^\circ\text{C}$.
(3) $r_{on(Flat)}$ is the difference of r_{on} in a given channel at specified voltages.
(4) Δr_{on} is the difference of r_{on} from center (A_4 , A_5) ports to any other port.

Switching Characteristics

over recommended operating free-air temperature range, $V_{DD} = 3.3 \text{ V} \pm 0.3 \text{ V}$, $R_L = 200 \ \Omega$, $C_L = 10 \text{ pF}$
 (unless otherwise noted) (see Figures 4 and 5)

PARAMETER	FROM (INPUT)	TO (OUTPUT)	MIN	TYP ⁽¹⁾	MAX	UNIT
t_{pd} ⁽²⁾	A or B	B or A		0.25		ns
t_{PZH} , t_{PZL}	SEL	A or B	1.5		11.5	ns
t_{PHZ} , t_{PLZ}	SEL	A or B	1		8.5	ns
$t_{sk(o)}$ ⁽³⁾	A or B	B or A		0.1	0.2	ns
$t_{sk(p)}$ ⁽⁴⁾				0.1	0.2	ns

- (1) All typical values are at $V_{DD} = 3.3 \text{ V}$ (unless otherwise noted), $T_A = 25^\circ\text{C}$.
 (2) The propagation delay is the calculated RC time constant of the typical ON-state resistance of the switch and the specified load capacitance when driven by an ideal voltage source (zero output impedance).
 (3) Output skew between center port (A_4 to A_5) to any other port
 (4) Skew between opposite transitions of the same output in a given device $|t_{PHL} - t_{PLH}|$

Dynamic Characteristics

over recommended operating free-air temperature range, $V_{DD} = 3.3 \text{ V} \pm 0.3 \text{ V}$ (unless otherwise noted)

PARAMETER	TEST CONDITIONS			TYP ⁽¹⁾	UNIT
X_{TALK}	$R_L = 100 \ \Omega$,	$f = 250 \text{ MHz}$,	See Figure 7	-41	dB
O_{IRR}	$R_L = 100 \ \Omega$,	$f = 250 \text{ MHz}$,	See Figure 8	-39	dB
BW	$R_L = 100 \ \Omega$,	See Figure 6		900	MHz

- (1) All typical values are at $V_{DD} = 3.3 \text{ V}$ (unless otherwise noted), $T_A = 25^\circ\text{C}$.

OPERATING CHARACTERISTICS

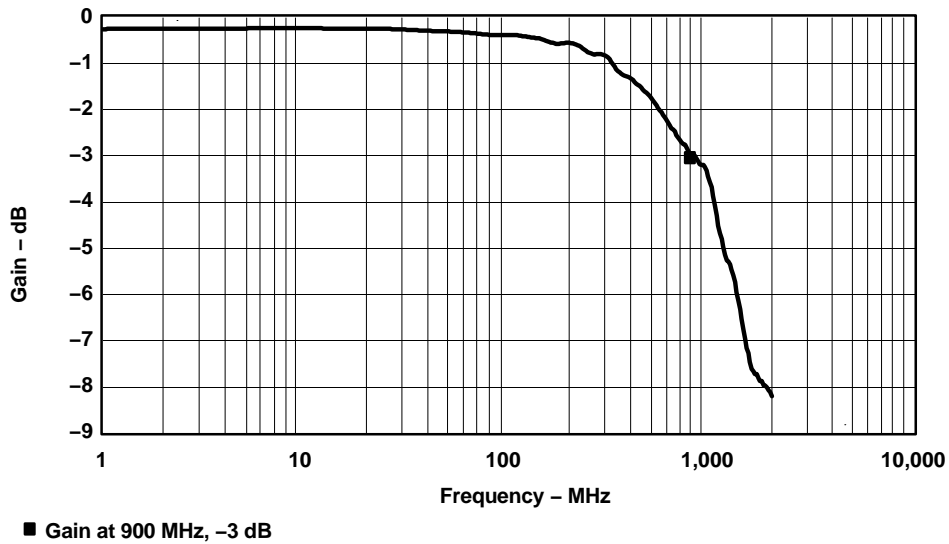

Figure 1. Gain vs Frequency

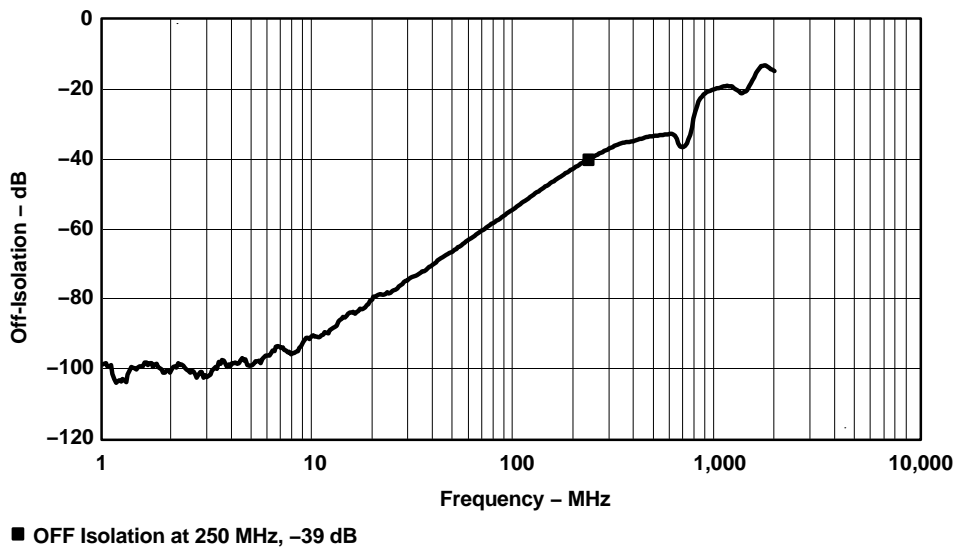

Figure 2. OFF Isolation vs Frequency

OPERATING CHARACTERISTICS (continued)

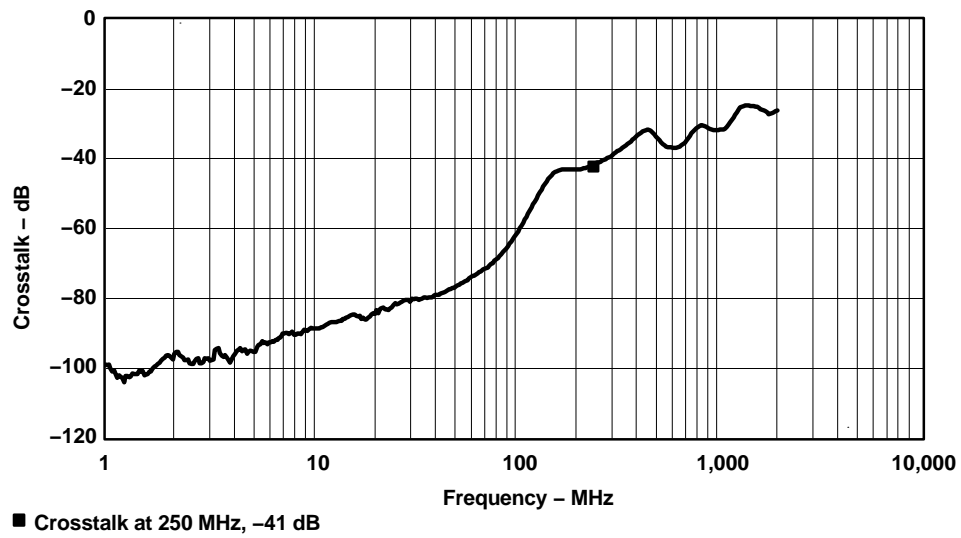
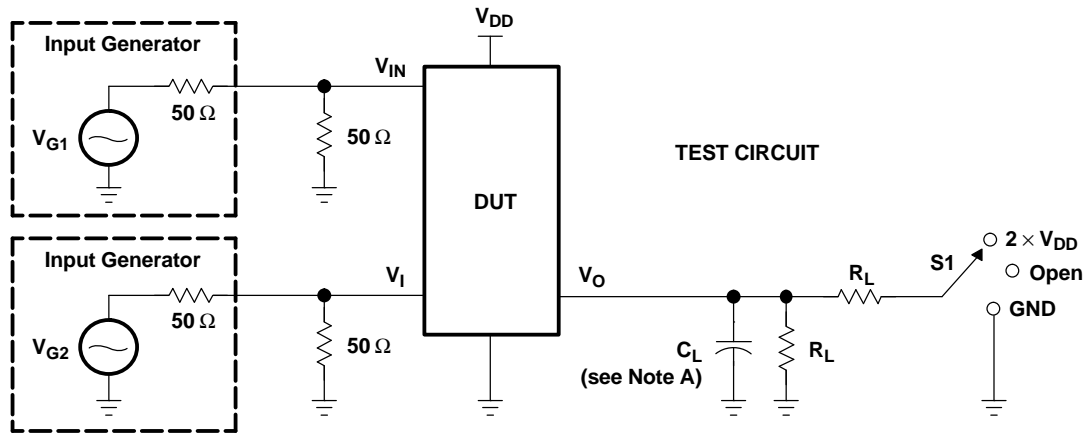
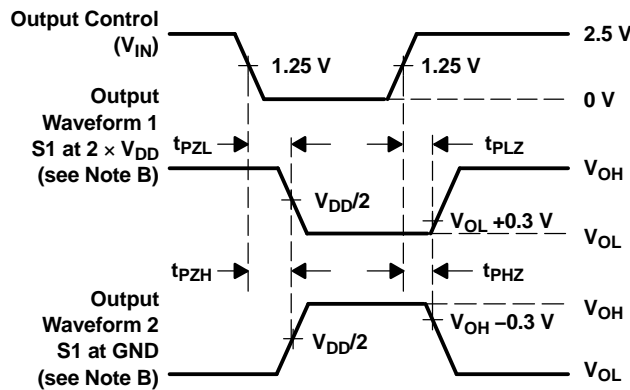

Figure 3. Crosstalk vs Frequency

PARAMETER MEASUREMENT INFORMATION
(Enable and Disable Times)



TEST	V _{DD}	S1	R _L	V _I	C _L	V _Δ
t _{PLZ} /t _{PZL}	3.3 V ± 0.3 V	2 × V _{DD}	200 Ω	GND	10 pF	0.3 V
t _{PHZ} /t _{PZH}	3.3 V ± 0.3 V	GND	200 Ω	V _{DD}	10 pF	0.3 V



VOLTAGE WAVEFORMS
ENABLE AND DISABLE TIMES

- NOTES: A. C_L includes probe and jig capacitance.
B. Waveform 1 is for an output with internal conditions such that the output is low, except when disabled by the output control. Waveform 2 is for an output with internal conditions such that the output is high, except when disabled by the output control.
C. All input pulses are supplied by generators having the following characteristics: PRR ≤ 10 MHz, Z_O = 50 Ω, t_r ≤ 2.5 ns, t_f ≤ 2.5 ns.
D. The outputs are measured one at a time, with one transition per measurement.
E. t_{PLZ} and t_{PHZ} are the same as t_{dis}.
F. t_{PZL} and t_{PZH} are the same as t_{en}.

Figure 4. Test Circuit and Voltage Waveforms

PARAMETER MEASUREMENT INFORMATION
(Skew)

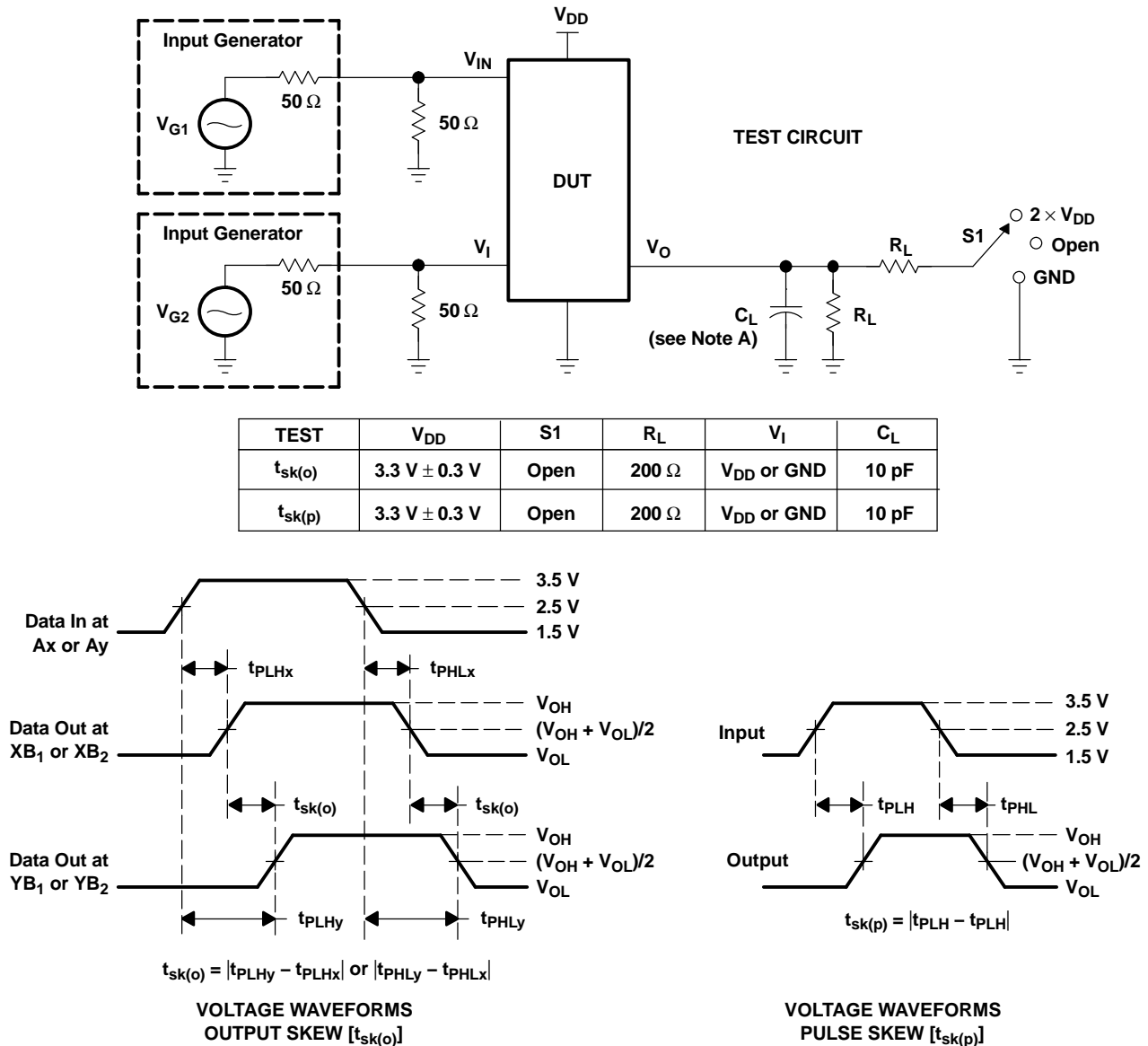

- NOTES: A. C_L includes probe and jig capacitance.
 B. Waveform 1 is for an output with internal conditions such that the output is low, except when disabled by the output control. Waveform 2 is for an output with internal conditions such that the output is high, except when disabled by the output control.
 C. All input pulses are supplied by generators having the following characteristics: PRR ≤ 10 MHz, Z_O = 50 Ω, t_r ≤ 2.5 ns, t_f ≤ 2.5 ns.
 D. The outputs are measured one at a time, with one transition per measurement.

Figure 5. Test Circuit and Voltage Waveforms

PARAMETER MEASUREMENT INFORMATION

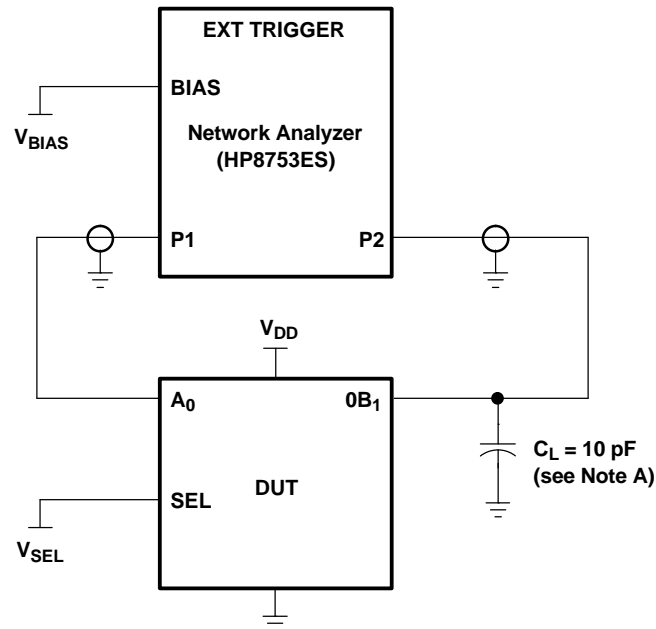

A. C_L includes probe and jig capacitance.

Figure 6. Test Circuit for Frequency Response (BW)

Frequency response is measured at the output of the ON channel. For example, when $V_{SEL} = 0$ and A_0 is the input, the output is measured at $0B_1$. All unused analog I/O ports are left open.

HP8753ES Setup

Average = 4
RBW = 3 kHz
 $V_{BIAS} = 0.35$ V
ST = 2 s
P1 = 0 dBm

PARAMETER MEASUREMENT INFORMATION (continued)

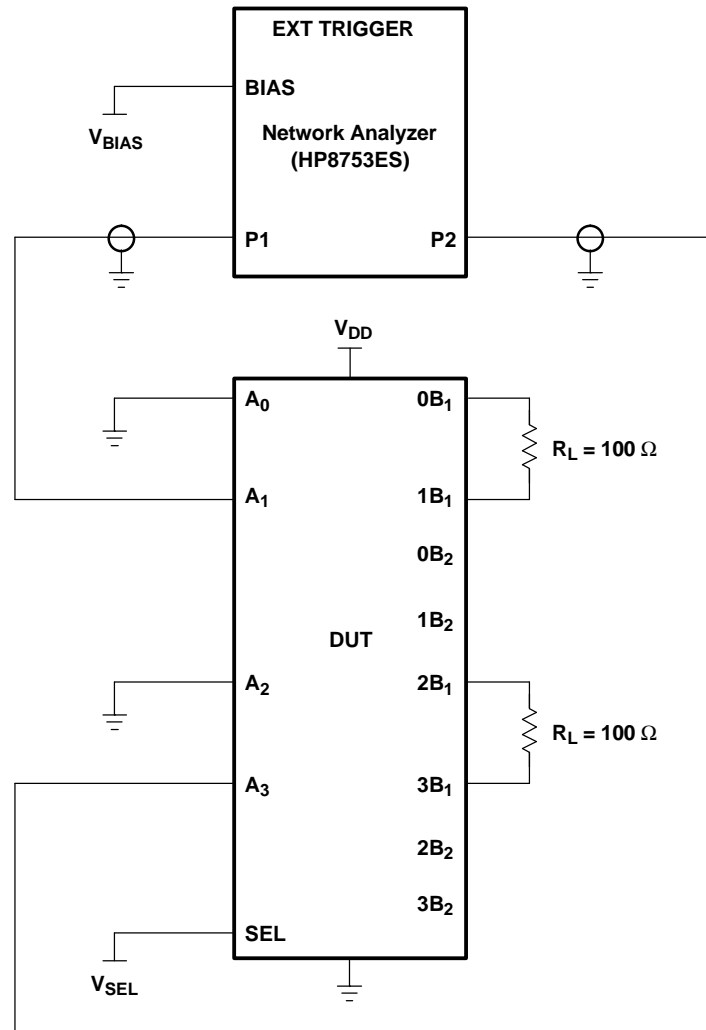

- A. C_L includes probe and jig capacitance.
- B. A 50- Ω termination resistor is needed to match the loading of the network analyzer.

Figure 7. Test Circuit for Crosstalk (X_{TALK})

Crosstalk is measured at the output of the nonadjacent ON channel. For example, when $V_{SEL} = 0$ and A_1 is the input, the output is measured at A_3 . All unused analog input (A) ports are connected to GND, and output (B) ports are left open.

HP8753ES Setup

Average = 4
 RBW = 3 kHz
 $V_{BIAS} = 0.35$ V
 ST = 2 s
 P1 = 0 dBm

PARAMETER MEASUREMENT INFORMATION (continued)

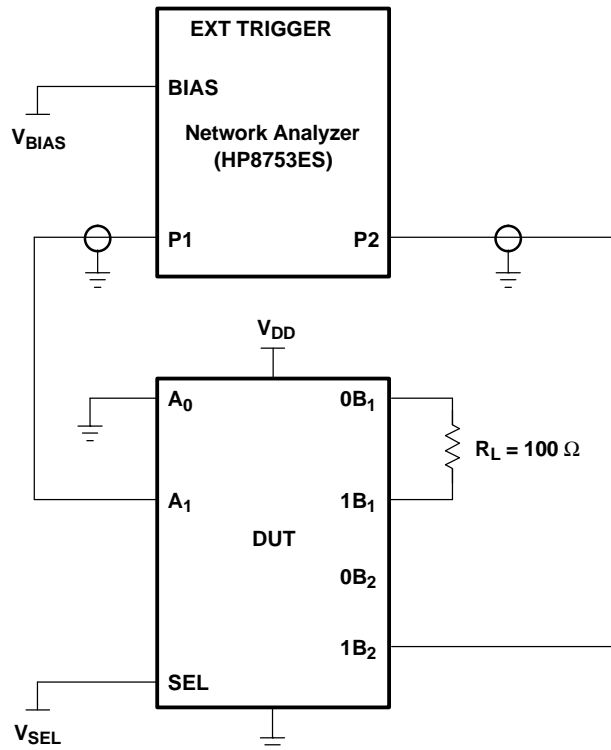

- A. C_L includes probe and jig capacitance.
- B. A 50- Ω termination resistor is needed to match the loading of the network analyzer.

Figure 8. Test Circuit for Off Isolation (O_{IRR})

OFF isolation is measured at the output of the OFF channel. For example, when $V_{SEL} = GND$ and A_1 is the input, the output is measured at $1B_2$. All unused analog input (A) ports are connected to ground, and output (B) ports are left open.

HP8753ES Setup

Average = 4
 RBW = 3 kHz
 $V_{BIAS} = 0.35$ V
 ST = 2 s
 P1 = 0 dBm

PACKAGING INFORMATION

Orderable Device	Status (1)	Package Type	Package Drawing	Pins	Package Qty	Eco Plan (2)	Lead/Ball Finish (6)	MSL Peak Temp (3)	Op Temp (°C)	Device Marking (4/5)	Samples
TS3L301DGG	ACTIVE	TSSOP	DGG	48	40	Green (RoHS & no Sb/Br)	CU NIPDAU	Level-1-260C-UNLIM	-40 to 85	TS3L301	Samples
TS3L301DGGR	ACTIVE	TSSOP	DGG	48	2000	Green (RoHS & no Sb/Br)	CU NIPDAU	Level-1-260C-UNLIM	-40 to 85	TS3L301	Samples
TS3L301DGGRE4	ACTIVE	TSSOP	DGG	48	2000	Green (RoHS & no Sb/Br)	CU NIPDAU	Level-1-260C-UNLIM	-40 to 85	TS3L301	Samples
TS3L301DGGRG4	ACTIVE	TSSOP	DGG	48	2000	Green (RoHS & no Sb/Br)	CU NIPDAU	Level-1-260C-UNLIM	-40 to 85	TS3L301	Samples
TS3L301DGVV	ACTIVE	TVSOP	DGV	48	2000	Green (RoHS & no Sb/Br)	CU NIPDAU	Level-1-260C-UNLIM	-40 to 85	TK301	Samples

(1) The marketing status values are defined as follows:

ACTIVE: Product device recommended for new designs.

LIFEBUY: TI has announced that the device will be discontinued, and a lifetime-buy period is in effect.

NRND: Not recommended for new designs. Device is in production to support existing customers, but TI does not recommend using this part in a new design.

PREVIEW: Device has been announced but is not in production. Samples may or may not be available.

OBSOLETE: TI has discontinued the production of the device.

(2) **RoHS:** TI defines "RoHS" to mean semiconductor products that are compliant with the current EU RoHS requirements for all 10 RoHS substances, including the requirement that RoHS substance do not exceed 0.1% by weight in homogeneous materials. Where designed to be soldered at high temperatures, "RoHS" products are suitable for use in specified lead-free processes. TI may reference these types of products as "Pb-Free".

RoHS Exempt: TI defines "RoHS Exempt" to mean products that contain lead but are compliant with EU RoHS pursuant to a specific EU RoHS exemption.

Green: TI defines "Green" to mean the content of Chlorine (Cl) and Bromine (Br) based flame retardants meet JS709B low halogen requirements of <=1000ppm threshold. Antimony trioxide based flame retardants must also meet the <=1000ppm threshold requirement.

(3) MSL, Peak Temp. - The Moisture Sensitivity Level rating according to the JEDEC industry standard classifications, and peak solder temperature.

(4) There may be additional marking, which relates to the logo, the lot trace code information, or the environmental category on the device.

(5) Multiple Device Markings will be inside parentheses. Only one Device Marking contained in parentheses and separated by a "-" will appear on a device. If a line is indented then it is a continuation of the previous line and the two combined represent the entire Device Marking for that device.

(6) Lead/Ball Finish - Orderable Devices may have multiple material finish options. Finish options are separated by a vertical ruled line. Lead/Ball Finish values may wrap to two lines if the finish value exceeds the maximum column width.

Important Information and Disclaimer: The information provided on this page represents TI's knowledge and belief as of the date that it is provided. TI bases its knowledge and belief on information provided by third parties, and makes no representation or warranty as to the accuracy of such information. Efforts are underway to better integrate information from third parties. TI has taken and continues to take reasonable steps to provide representative and accurate information but may not have conducted destructive testing or chemical analysis on incoming materials and chemicals. TI and TI suppliers consider certain information to be proprietary, and thus CAS numbers and other limited information may not be available for release.

In no event shall TI's liability arising out of such information exceed the total purchase price of the TI part(s) at issue in this document sold by TI to Customer on an annual basis.

TAPE AND REEL INFORMATION



QUADRANT ASSIGNMENTS FOR PIN 1 ORIENTATION IN TAPE



*All dimensions are nominal

Device	Package Type	Package Drawing	Pins	SPQ	Reel Diameter (mm)	Reel Width W1 (mm)	A0 (mm)	B0 (mm)	K0 (mm)	P1 (mm)	W (mm)	Pin1 Quadrant
TS3L301DGGR	TSSOP	DGG	48	2000	330.0	24.4	8.6	13.0	1.8	12.0	24.0	Q1
TS3L301DGVR	TVSOP	DGV	48	2000	330.0	16.4	7.1	10.2	1.6	12.0	16.0	Q1

TAPE AND REEL BOX DIMENSIONS

*All dimensions are nominal

Device	Package Type	Package Drawing	Pins	SPQ	Length (mm)	Width (mm)	Height (mm)
TS3L301DGGR	TSSOP	DGG	48	2000	367.0	367.0	45.0
TS3L301DGVR	TVSOP	DGV	48	2000	367.0	367.0	38.0

DGV (R-PDSO-G**)

PLASTIC SMALL-OUTLINE

24 PINS SHOWN



- NOTES: A. All linear dimensions are in millimeters.
 B. This drawing is subject to change without notice.
 C. Body dimensions do not include mold flash or protrusion, not to exceed 0,15 per side.
 D. Falls within JEDEC: 24/48 Pins – MO-153
 14/16/20/56 Pins – MO-194

DGG (R-PDSO-G**)

PLASTIC SMALL-OUTLINE PACKAGE

48 PINS SHOWN

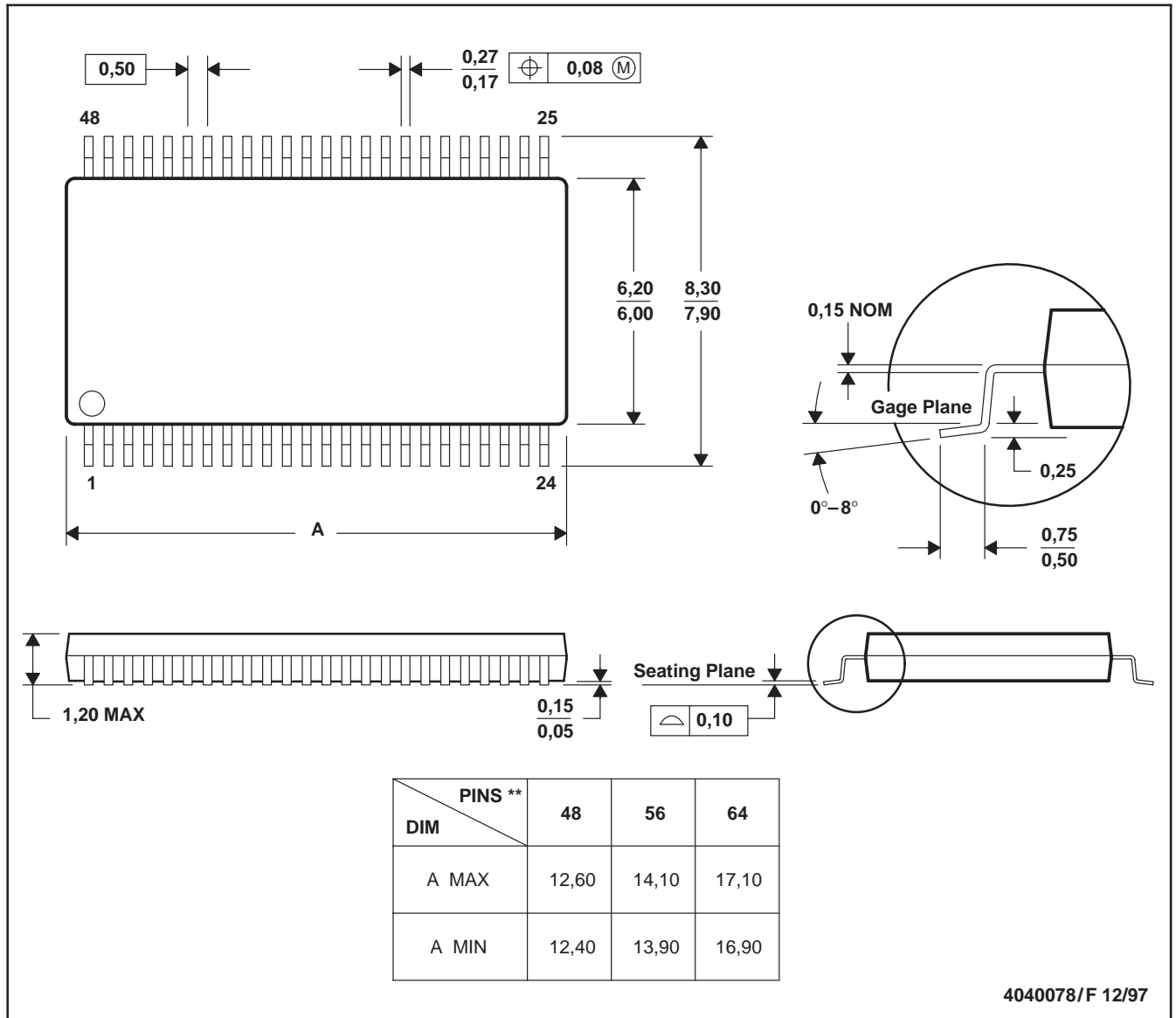

- NOTES: A. All linear dimensions are in millimeters.
 B. This drawing is subject to change without notice.
 C. Body dimensions do not include mold protrusion not to exceed 0,15.
 D. Falls within JEDEC MO-153

IMPORTANT NOTICE

Texas Instruments Incorporated (TI) reserves the right to make corrections, enhancements, improvements and other changes to its semiconductor products and services per JESD46, latest issue, and to discontinue any product or service per JESD48, latest issue. Buyers should obtain the latest relevant information before placing orders and should verify that such information is current and complete.

TI's published terms of sale for semiconductor products (<http://www.ti.com/sc/docs/stdterms.htm>) apply to the sale of packaged integrated circuit products that TI has qualified and released to market. Additional terms may apply to the use or sale of other types of TI products and services.

Reproduction of significant portions of TI information in TI data sheets is permissible only if reproduction is without alteration and is accompanied by all associated warranties, conditions, limitations, and notices. TI is not responsible or liable for such reproduced documentation. Information of third parties may be subject to additional restrictions. Resale of TI products or services with statements different from or beyond the parameters stated by TI for that product or service voids all express and any implied warranties for the associated TI product or service and is an unfair and deceptive business practice. TI is not responsible or liable for any such statements.

Buyers and others who are developing systems that incorporate TI products (collectively, "Designers") understand and agree that Designers remain responsible for using their independent analysis, evaluation and judgment in designing their applications and that Designers have full and exclusive responsibility to assure the safety of Designers' applications and compliance of their applications (and of all TI products used in or for Designers' applications) with all applicable regulations, laws and other applicable requirements. Designer represents that, with respect to their applications, Designer has all the necessary expertise to create and implement safeguards that (1) anticipate dangerous consequences of failures, (2) monitor failures and their consequences, and (3) lessen the likelihood of failures that might cause harm and take appropriate actions. Designer agrees that prior to using or distributing any applications that include TI products, Designer will thoroughly test such applications and the functionality of such TI products as used in such applications.

TI's provision of technical, application or other design advice, quality characterization, reliability data or other services or information, including, but not limited to, reference designs and materials relating to evaluation modules, (collectively, "TI Resources") are intended to assist designers who are developing applications that incorporate TI products; by downloading, accessing or using TI Resources in any way, Designer (individually or, if Designer is acting on behalf of a company, Designer's company) agrees to use any particular TI Resource solely for this purpose and subject to the terms of this Notice.

TI's provision of TI Resources does not expand or otherwise alter TI's applicable published warranties or warranty disclaimers for TI products, and no additional obligations or liabilities arise from TI providing such TI Resources. TI reserves the right to make corrections, enhancements, improvements and other changes to its TI Resources. TI has not conducted any testing other than that specifically described in the published documentation for a particular TI Resource.

Designer is authorized to use, copy and modify any individual TI Resource only in connection with the development of applications that include the TI product(s) identified in such TI Resource. NO OTHER LICENSE, EXPRESS OR IMPLIED, BY ESTOPPEL OR OTHERWISE TO ANY OTHER TI INTELLECTUAL PROPERTY RIGHT, AND NO LICENSE TO ANY TECHNOLOGY OR INTELLECTUAL PROPERTY RIGHT OF TI OR ANY THIRD PARTY IS GRANTED HEREIN, including but not limited to any patent right, copyright, mask work right, or other intellectual property right relating to any combination, machine, or process in which TI products or services are used. Information regarding or referencing third-party products or services does not constitute a license to use such products or services, or a warranty or endorsement thereof. Use of TI Resources may require a license from a third party under the patents or other intellectual property of the third party, or a license from TI under the patents or other intellectual property of TI.

TI RESOURCES ARE PROVIDED "AS IS" AND WITH ALL FAULTS. TI DISCLAIMS ALL OTHER WARRANTIES OR REPRESENTATIONS, EXPRESS OR IMPLIED, REGARDING RESOURCES OR USE THEREOF, INCLUDING BUT NOT LIMITED TO ACCURACY OR COMPLETENESS, TITLE, ANY EPIDEMIC FAILURE WARRANTY AND ANY IMPLIED WARRANTIES OF MERCHANTABILITY, FITNESS FOR A PARTICULAR PURPOSE, AND NON-INFRINGEMENT OF ANY THIRD PARTY INTELLECTUAL PROPERTY RIGHTS. TI SHALL NOT BE LIABLE FOR AND SHALL NOT DEFEND OR INDEMNIFY DESIGNER AGAINST ANY CLAIM, INCLUDING BUT NOT LIMITED TO ANY INFRINGEMENT CLAIM THAT RELATES TO OR IS BASED ON ANY COMBINATION OF PRODUCTS EVEN IF DESCRIBED IN TI RESOURCES OR OTHERWISE. IN NO EVENT SHALL TI BE LIABLE FOR ANY ACTUAL, DIRECT, SPECIAL, COLLATERAL, INDIRECT, PUNITIVE, INCIDENTAL, CONSEQUENTIAL OR EXEMPLARY DAMAGES IN CONNECTION WITH OR ARISING OUT OF TI RESOURCES OR USE THEREOF, AND REGARDLESS OF WHETHER TI HAS BEEN ADVISED OF THE POSSIBILITY OF SUCH DAMAGES.

Unless TI has explicitly designated an individual product as meeting the requirements of a particular industry standard (e.g., ISO/TS 16949 and ISO 26262), TI is not responsible for any failure to meet such industry standard requirements.

Where TI specifically promotes products as facilitating functional safety or as compliant with industry functional safety standards, such products are intended to help enable customers to design and create their own applications that meet applicable functional safety standards and requirements. Using products in an application does not by itself establish any safety features in the application. Designers must ensure compliance with safety-related requirements and standards applicable to their applications. Designer may not use any TI products in life-critical medical equipment unless authorized officers of the parties have executed a special contract specifically governing such use. Life-critical medical equipment is medical equipment where failure of such equipment would cause serious bodily injury or death (e.g., life support, pacemakers, defibrillators, heart pumps, neurostimulators, and implantables). Such equipment includes, without limitation, all medical devices identified by the U.S. Food and Drug Administration as Class III devices and equivalent classifications outside the U.S.

TI may expressly designate certain products as completing a particular qualification (e.g., Q100, Military Grade, or Enhanced Product). Designers agree that it has the necessary expertise to select the product with the appropriate qualification designation for their applications and that proper product selection is at Designers' own risk. Designers are solely responsible for compliance with all legal and regulatory requirements in connection with such selection.

Designer will fully indemnify TI and its representatives against any damages, costs, losses, and/or liabilities arising out of Designer's non-compliance with the terms and provisions of this Notice.

Looking for pricing, stock, or lifecycle information?

Click below to explore more details on WIN SOURCE:

 [View TS3L301DGVR on WIN SOURCE](#)

 [Texas Instruments](#) Information

Optimize Your Supply Chain with WIN SOURCE Solutions

-  Global Sourcing Solution
-  Obsolete Management
-  Cost Control Management
-  Shortage Management
-  Alternative Solution
-  Excess Inventory Management