



**THE DATASHEET OF
TS3DS10224RUKR**



TS3DS10224 High-Speed Differential Crosspoint, 1:4 Differential Multiplexer and Demultiplexer, 2 Channel Differential 1:2 Multiplexer and Demultiplexer, or Fan-Out Switch

1 Features

- Can be configured for
 - Differential Crosspoint Switching
 - Differential Single Channel 1:4 Multiplexer and Demultiplexer
 - Differential 2-Channel 1:2 Multiplexer and Demultiplexer
 - Differential Fan-Out of Signal Pair to Two Ports Simultaneously
- Bidirectional Operation
- Fail-Safe Protection: I_{OFF} Protection Prevents Current Leakage in Powered-Down State ($V_{CC} = 0\text{ V}$)
- High BW (1.2 GHz Typical)
- Low R_{ON} and C_{ON} :
 - 13- Ω R_{ON} Typical
 - 9-pF C_{ON} Typical
- ESD Performance (I/O Pins)
 - ± 8 -kV Contact Discharge (IEC61000-4-2)
 - 2-kV Human-Body Model per JESD22-A114E (to GND)
- ESD Performance (All Pins)
 - 2-kV Human-Body Model per JESD22-A114E
- Small WQFN package (3.00 mm \times 3.00 mm, 0.4-mm pitch)

2 Applications

- Differential Crosspoint Switching
- Desktop and Notebook Computers
- DisplayPort Auxiliary Channel Multiplexing
- USB 2.0 Multiplexing
- Netbooks, eBooks, and Tablets

3 Description

The TS3DS10224 device is a bidirectional differential crosspoint, 1:4, or 1:2 multiplexer and demultiplexer; or fan-out switch for high-speed differential signal applications (up to 720 Mbps). The TS3DS10224 logic table can route any input to any output creating a wide range of possible switching or multiplexing configurations. Common configurations include: differential crosspoint switching, differential 1:4 mux, or differential 2-channel 1:2 multiplexer and demultiplexer. The TS3DS10224 offers a high BW of 1.2 GHz with channel R_{ON} of 13 Ω (typical).

The TS3DS10224 can also be used to fan out a differential signal pair to two ports simultaneously (fan-out configuration). The BW performance is lower in this configuration.

The TS3DS10224 operates with a 3-V to 3.6-V power supply. It features ESD protection of up to ± 8 -kV contact discharge and 2-kV human-body model on its I/O pins.

The TS3DS10224 provides fail-safe protection by isolating the I/O pins with high impedance when the power supply (V_{CC}) is not present.

Device Information⁽¹⁾

PART NUMBER	PACKAGE	BODY SIZE (NOM)
TS3DS10224	WQFN (20)	3.00 mm \times 3.00 mm

(1) For all available packages, see the orderable addendum at the end of the data sheet.

Functional Block Diagram

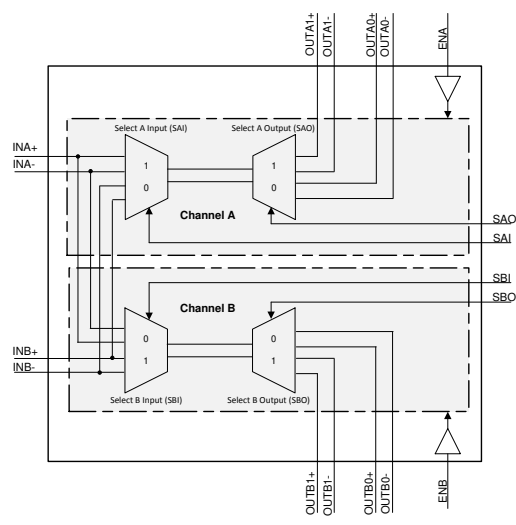

Table of Contents

1 Features	1	7 Parameter Measurement Information	9
2 Applications	1	8 Detailed Description	12
3 Description	1	8.1 Overview	12
4 Revision History	2	8.2 Functional Block Diagram	12
5 Pin Configuration and Functions	3	8.3 Feature Description	12
6 Specifications	4	8.4 Device Functional Modes	13
6.1 Absolute Maximum Ratings	4	9 Application and Implementation	19
6.2 ESD Ratings	4	9.1 Application Information	19
6.3 Recommended Operating Conditions	4	9.2 Typical Applications	19
6.4 Thermal Information	4	10 Power Supply Recommendations	22
6.5 Electrical Characteristics:		11 Layout	23
Differential 1:4 or 2-Channel 1:2 Configurations	5	11.1 Layout Guidelines	23
6.6 Electrical Characteristics: Fan-Out 1:2		11.2 Layout Example	24
Configurations	5	12 Device and Documentation Support	25
6.7 Switching Characteristics:		12.1 Documentation Support	25
Differential 1:4 or 2-Channel 1:2 Configurations	5	12.2 Receiving Notification of Documentation Updates	25
6.8 Switching Characteristics: Fan-Out 1:2		12.3 Community Resources	25
Configurations	6	12.4 Trademarks	25
6.9 Dynamic Characteristics:		12.5 Electrostatic Discharge Caution	25
Differential 1:4 or 2-Channel 1:2 Configurations	6	12.6 Glossary	25
6.10 Dynamic Characteristics: Fan-Out 1:2		13 Mechanical, Packaging, and Orderable	
Configurations	6	Information	25
6.11 Typical Characteristics	7		

4 Revision History

NOTE: Page numbers for previous revisions may differ from page numbers in the current version.

Changes from Revision D (May 2019) to Revision E	Page
• Changed mapping for OUTB0, and OUTB1 in Table 6	18
<hr/>	
Changes from Revision C (November 2017) to Revision D	Page
• Changed Figure 2	7
<hr/>	
Changes from Revision B (December 2016) to Revision C	Page
• Changed columns OUTA1, OUTB0, and OUTB1 in Table 6	18
<hr/>	
Changes from Revision A (May 2013) to Revision B	Page
• Added <i>Device Information</i> table, <i>Pin Configuration and Functions</i> section, <i>Specifications</i> section, <i>ESD Ratings</i> table, <i>Detailed Description</i> section, <i>Application and Implementation</i> section, <i>Power Supply Recommendations</i> section, <i>Layout</i> section, <i>Device and Documentation Support</i> section, and <i>Mechanical, Packaging, and Orderable Information</i> section	1
• Added <i>Thermal Information</i> table	4
• Changed R _{θJA} value From: 82.7 To: 45.2	4
<hr/>	
Changes from Original (June 2011) to Revision A	Page
• Replaced 1 page preview with full document	1

5 Pin Configuration and Functions

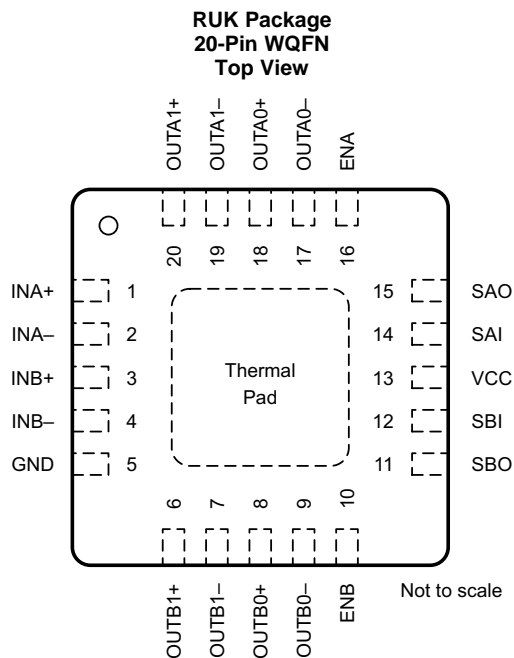

Pin Functions

PIN		I/O	DESCRIPTION
NO.	NAME		
1	INA+	I/O	A channel signal path
2	INA-	I/O	A channel signal path
3	INB+	I/O	B channel signal path
4	INB-	I/O	B channel signal path
5	GND	—	Ground
6	OUTB1+	I/O	B channel signal path
7	OUTB1-	I/O	B channel signal path
8	OUTB0+	I/O	B channel signal path
9	OUTB0-	I/O	B channel signal path
10	ENB	I	Enable B channel: LOW = disables channel B and places the signal path in high impedance state, HIGH = enables channel B.
11	SBO	I	Select B channel output, controls output selection: LOW = selects OUTB0 signals, HIGH = selects OUTB1 signals.
12	SBI	I	Select B channel input, controls input selection: LOW = selects INA signals to pass through the B channel, HIGH = selects INB signals to pass through the B channel.
13	VCC	—	Power supply
14	SAI	I	Select A channel input, controls input selection: LOW = selects INB signals to pass through the A channel, HIGH = selects INA signals to pass through the A channel.
15	SAO	I	Select A channel output, controls output selection: LOW = selects OUTA0 signals, HIGH = selects OUTA1 signals.
16	ENA	I	Enable A channel: LOW = disables channel A and places the signal path in high impedance state, HIGH = enables channel A.
17	OUTA0-	I/O	A channel signal path
18	OUTA0+	I/O	A channel signal path
19	OUTA1-	I/O	A channel signal path
20	OUTA1+	I/O	A channel signal path

6 Specifications

6.1 Absolute Maximum Ratings

Over operating free-air temperature range (unless otherwise noted).⁽¹⁾

	MIN	MAX	UNIT
Supply voltage	-0.3	4	V
Analog I/O voltage ⁽²⁾⁽³⁾⁽⁴⁾	-0.3	$V_{CC} + 0.3$	V
Control input voltage ⁽²⁾⁽⁴⁾ , V_{IN}	-0.3	$V_{CC} + 0.3$	V
ON-state switch current ⁽⁵⁾ , I_{IO}		±100	mA
Continuous current through VCC or GND		±100	mA
Storage temperature, T_{stg}	-65	150	°C

- (1) Stresses beyond those listed under *Absolute Maximum Ratings* may cause permanent damage to the device. These are stress ratings only, which do not imply functional operation of the device at these or any other conditions beyond those indicated under *Recommended Operating Conditions*. Exposure to absolute-maximum-rated conditions for extended periods may affect device reliability.
- (2) All voltages are with respect to ground, unless otherwise specified.
- (3) V_I and V_O are used to denote specific conditions for V_{IO} .
- (4) The input and output voltage rating may be exceeded if the input and output clamp-current ratings are observed.
- (5) I_I and I_O are used to denote specific conditions for I_{IO} .

6.2 ESD Ratings

		VALUE	UNIT
$V_{(ESD)}$ Electrostatic discharge	Human-body model (HBM), per ANSI/ESDA/JEDEC JS-001 ⁽¹⁾	±2500	V
	Charged-device model (CDM), per JEDEC specification JESD22-C101 or ANSI/ESDA/JEDEC JS-002 ⁽²⁾	±1000	

- (1) JEDEC document JEP155 states that 500-V HBM allows safe manufacturing with a standard ESD control process.
- (2) JEDEC document JEP157 states that 250-V CDM allows safe manufacturing with a standard ESD control process.

6.3 Recommended Operating Conditions

Over operating free-air temperature range (unless otherwise noted).⁽¹⁾⁽²⁾

		MIN	MAX	UNIT
V_{CC}	Supply voltage	3	3.6	V
V_{IH}	High-level control input voltage	$0.75 \times V_{CC}$	V_{CC}	V
V_{IL}	Low-level control input voltage	0	0.6	V
V_{IO}	Input and output voltage	0	V_{CC}	V
T_A	Operating free-air temperature	-40	85	°C

- (1) All unused control inputs of the device must be held at V_{CC} or GND to ensure proper device operation. See *Implications of Slow or Floating CMOS Inputs* (SCBA004).
- (2) TI recommends pulling down to ground unused I/O pins through a 1-k Ω resistor.

6.4 Thermal Information

THERMAL METRIC ⁽¹⁾		TS3DS10224	UNIT
		RUK (WQFN)	
		20 PINS	
$R_{\theta JA}$	Junction-to-ambient thermal resistance	45.2	°C/W
$R_{\theta JC(top)}$	Junction-to-case (top) thermal resistance	48.8	°C/W
$R_{\theta JB}$	Junction-to-board thermal resistance	17.1	°C/W
Ψ_{JT}	Junction-to-top characterization parameter	0.6	°C/W
Ψ_{JB}	Junction-to-board characterization parameter	17.1	°C/W
$R_{\theta JC(bot)}$	Junction-to-case (bottom) thermal resistance	3.7	°C/W

- (1) For more information about traditional and new thermal metrics, see the *Semiconductor and IC Package Thermal Metrics* application report.

6.5 Electrical Characteristics: Differential 1:4 or 2-Channel 1:2 Configurations

Minimum and maximum values are at $T_A = -40^{\circ}\text{C}$ to 85°C ; typical values are at $T_A = 25^{\circ}\text{C}$ (unless otherwise noted).⁽¹⁾

PARAMETER		TEST CONDITIONS	MIN	TYP	MAX	UNIT
V_{IK}	Digital input clamp voltage	$V_{CC} = 3.6\text{ V}$, $I_I = -18\text{ mA}$	-1.2	-0.9		V
I_{IN}	Digital input leakage current	$V_{CC} = 3.6\text{ V}$, $V_{IN} = 0\text{ to }3.6\text{ V}$			± 2	μA
I_{OZ}	OFF-state leakage current ⁽²⁾	$V_{CC} = 3.6\text{ V}$, $V_O = 0\text{ V to }3.6\text{ V}$, $V_I = 0\text{ V}$, Switch OFF			± 2	μA
I_{OFF}	Power off leakage current	$V_{CC} = 0\text{ V}$, $V_{IN} = V_{CC}$ or GND, $V_{IO} = 0\text{ V to }3.6\text{ V}$			± 5	μA
I_{CC}	Supply current	$V_{CC} = 3.6\text{ V}$, $I_{IO} = 0$, Switch ON or OFF		50	100	μA
C_{IN}	Digital input capacitance	$V_{CC} = 3.3\text{ V}$, $V_{IN} = V_{CC}$ or GND		3	5	pF
$C_{IO(OFF)}$	OFF capacitance	$V_{CC} = 3.3\text{ V}$, $V_{IO} = 3.3\text{ V}$ or 0, $f = 10\text{ MHz}$, Switch OFF		6	7	pF
$C_{IO(ON)}$	ON capacitance	$V_{CC} = 3.3\text{ V}$, $V_{IO} = 3.3\text{ V}$ or 0, $f = 10\text{ MHz}$, Switch ON		9	10	pF
r_{ON}	ON-state resistance	$V_{CC} = 3.6\text{ V}$, $V_I = V_{CC}$, $I_O = -30\text{ mA}$ $V_{CC} = 3.3\text{ V}$, $V_I = 0.5\text{ V}$, $I_O = -30\text{ mA}$		13	19	Ω
Δr_{ON}	ON-state resistance match between channels	$V_{CC} = 3\text{ V}$, $V_I = 0\text{ to }V_{CC}$, $I_O = -30\text{ mA}$		2	2.5	Ω
$r_{ON(Flat)}$	ON-state resistance flatness	$V_{CC} = 3\text{ V}$, $V_I = 1.5\text{ V}$ and V_{CC} , $I_O = -30\text{ mA}$		4	6	Ω

(1) V_{IN} and I_{IN} refer to the digital control input pins.

(2) For I/O ports, the parameter I_{OZ} includes the input leakage current.

6.6 Electrical Characteristics: Fan-Out 1:2 Configurations

$T_A = -40^{\circ}\text{C}$ to 85°C ; typical values are at $V_{CC} = 3.3\text{ V}$, $T_A = 25^{\circ}\text{C}$ (unless otherwise noted).⁽¹⁾

PARAMETER		TEST CONDITIONS	MIN	TYP	MAX	UNIT
V_{IK}	Digital input clamp voltage	$V_{CC} = 3.6\text{ V}$, $I_I = -18\text{ mA}$	-1.2	-0.9		V
I_{IN}	Digital input leakage current	$V_{CC} = 3.6\text{ V}$, $V_{IN} = 0\text{ to }3.6\text{ V}$			± 2	μA
I_{OZ}	OFF-state leakage current ⁽²⁾	$V_{CC} = 3.6\text{ V}$, $V_O = 0\text{ V to }3.6\text{ V}$, $V_I = 0\text{ V}$, Switch OFF			± 2	μA
I_{OFF}	Power off leakage current	$V_{CC} = 0\text{ V}$, $V_{IN} = V_{CC}$ or GND, $V_{IO} = 0\text{ V to }3.6\text{ V}$			± 5	μA
I_{CC}	Supply current	$V_{CC} = 3.6\text{ V}$, $I_{IO} = 0$, Switch ON or OFF		50	100	μA
C_{IN}	Digital input capacitance	$V_{CC} = 3.3\text{ V}$, $V_{IN} = V_{CC}$ or GND		3	5	pF
$C_{IO(OFF)}$	OFF capacitance	$V_{CC} = 3.3\text{ V}$, $V_{IO} = 3.3\text{ V}$ or 0, $f = 10\text{ MHz}$, Switch OFF		6	7	pF
$C_{IO(ON)}$	ON capacitance	$V_{CC} = 3.3\text{ V}$, $V_{IO} = 3.3\text{ V}$ or 0, $f = 10\text{ MHz}$, Switch ON		12	13	pF
r_{ON}	ON-state resistance	$V_{CC} = 3.6\text{ V}$, $V_I = V_{CC}$, $I_O = -30\text{ mA}$		13	19	Ω
Δr_{ON}	ON-state resistance match between channels	$V_{CC} = 3\text{ V}$, $V_I = 0\text{ to }V_{CC}$, $I_O = -30\text{ mA}$		2	2.5	Ω
$r_{ON(Flat)}$	ON-state resistance flatness	$V_{CC} = 3\text{ V}$, $V_I = 1.5\text{ V}$ and V_{CC} , $I_O = -30\text{ mA}$		4	6	Ω

(1) V_{IN} and I_{IN} refer to control inputs. V_I , V_O , I_I , and I_O refer to data pins.

(2) For I/O ports, the parameter I_{OZ} includes the input leakage current.

6.7 Switching Characteristics: Differential 1:4 or 2-Channel 1:2 Configurations

$T_A = -40^{\circ}\text{C}$ to 85°C , $V_{CC} = 3.3\text{ V} \pm 10\%$, GND = 0 V (unless otherwise noted).

PARAMETER		TEST CONDITIONS	MIN	TYP	MAX	UNIT
t_{pd}	Propagation delay ⁽¹⁾	$R_L = 50\ \Omega$, $C_L = 2\text{ pF}$		50		ps
t_{ON}	SAI, SAO, SBI, or SBO to OUTAx or OUTBx	$R_L = 50\ \Omega$, $C_L = 2\text{ pF}$		40	100	ns
t_{OFF}	SAI, SAO, SBI, or SBO to OUTAx or OUTBx	$R_L = 50\ \Omega$, $C_L = 2\text{ pF}$		20	30	ns
$t_{sk(o)}$	Timing difference between output channels ⁽²⁾	$R_L = 50\ \Omega$, $C_L = 2\text{ pF}$		40		ps
$t_{sk(p)}$	Timing difference between propagation delays ⁽³⁾	$R_L = 50\ \Omega$, $C_L = 2\text{ pF}$		40		ps

(1) The propagation delay is the calculated RC time constant of the typical ON-State resistance of the switch and the specified load capacitance when driven by an ideal voltage source (zero output impedance).

(2) Output skew between center channel and any other channel.

(3) Skew between opposite transitions of the same output ($|t_{PHL} - t_{PLH}|$).

6.8 Switching Characteristics: Fan-Out 1:2 Configurations

 $T_A = -40^{\circ}\text{C}$ to 85°C , $V_{CC} = 3.3\text{ V} \pm 10\%$, $\text{GND} = 0\text{ V}$ (unless otherwise noted).

PARAMETER		TEST CONDITIONS	MIN	TYP	MAX	UNIT
t_{pd}	Propagation delay ⁽¹⁾	$R_L = 50\ \Omega$, $C_L = 2\ \text{pF}$		140		ps
t_{ON}	SAI, SAO, SBI, or SBO to OUTAx or OUTBx	$R = 50\ \Omega$, $C_L = 2\ \text{pF}$		40	100	ns
t_{OFF}	SAI, SAO, SBI, or SBO to OUTAx or OUTBx	$R_{LL} = 50\ \Omega$, $C_L = 2\ \text{pF}$		20	30	ns
$t_{sk(o)}$	Timing difference between output channels ⁽²⁾	$R_L = 50\ \Omega$, $C_L = 2\ \text{pF}$		60		ps
$t_{sk(p)}$	Timing difference between propagation delays ⁽³⁾	$R_L = 50\ \Omega$, $C_L = 2\ \text{pF}$		60		ps

- (1) The propagation delay is the calculated RC time constant of the typical ON-State resistance of the switch and the specified load capacitance when driven by an ideal voltage source (zero output impedance).
 (2) Output skew between center channel and any other channel.
 (3) Skew between opposite transitions of the same output ($|t_{PHL} - t_{PLH}|$).

6.9 Dynamic Characteristics: Differential 1:4 or 2-Channel 1:2 Configurations

 $T_A = -40^{\circ}\text{C}$ to 85°C ; typical values are at $V_{CC} = 3.3\text{ V} \pm 10\%$ and $T_A = 25^{\circ}\text{C}$ (unless otherwise noted).

PARAMETER		TEST CONDITIONS	TYP	UNIT
BW	Bandwidth	$R_L = 50\ \Omega$, Switch ON	1.2	GHz
O_{ISO}	OFF Isolation	$R_L = 50\ \Omega$, $f = 250\ \text{MHz}$	-30	dB
X_{TALK}	Crosstalk	$R_L = 50\ \Omega$, $f = 250\ \text{MHz}$	-30	dB

6.10 Dynamic Characteristics: Fan-Out 1:2 Configurations

 $T_A = -40^{\circ}\text{C}$ to 85°C ; typical values are at $V_{CC} = 3.3\text{ V} \pm 10\%$ and $T_A = 25^{\circ}\text{C}$ (unless otherwise noted).

PARAMETER		TEST CONDITIONS	TYP	UNIT
BW	Bandwidth	$R_L = 50\ \Omega$, Switch ON	500	MHz
O_{ISO}	OFF Isolation	$R_L = 50\ \Omega$, $f = 250\ \text{MHz}$	-30	dB
X_{TALK}	Crosstalk	$R_L = 50\ \Omega$, $f = 250\ \text{MHz}$	-30	dB

6.11 Typical Characteristics

6.11.1 Single-Channel 1:4 or Dual-Channel 1:2 Configurations

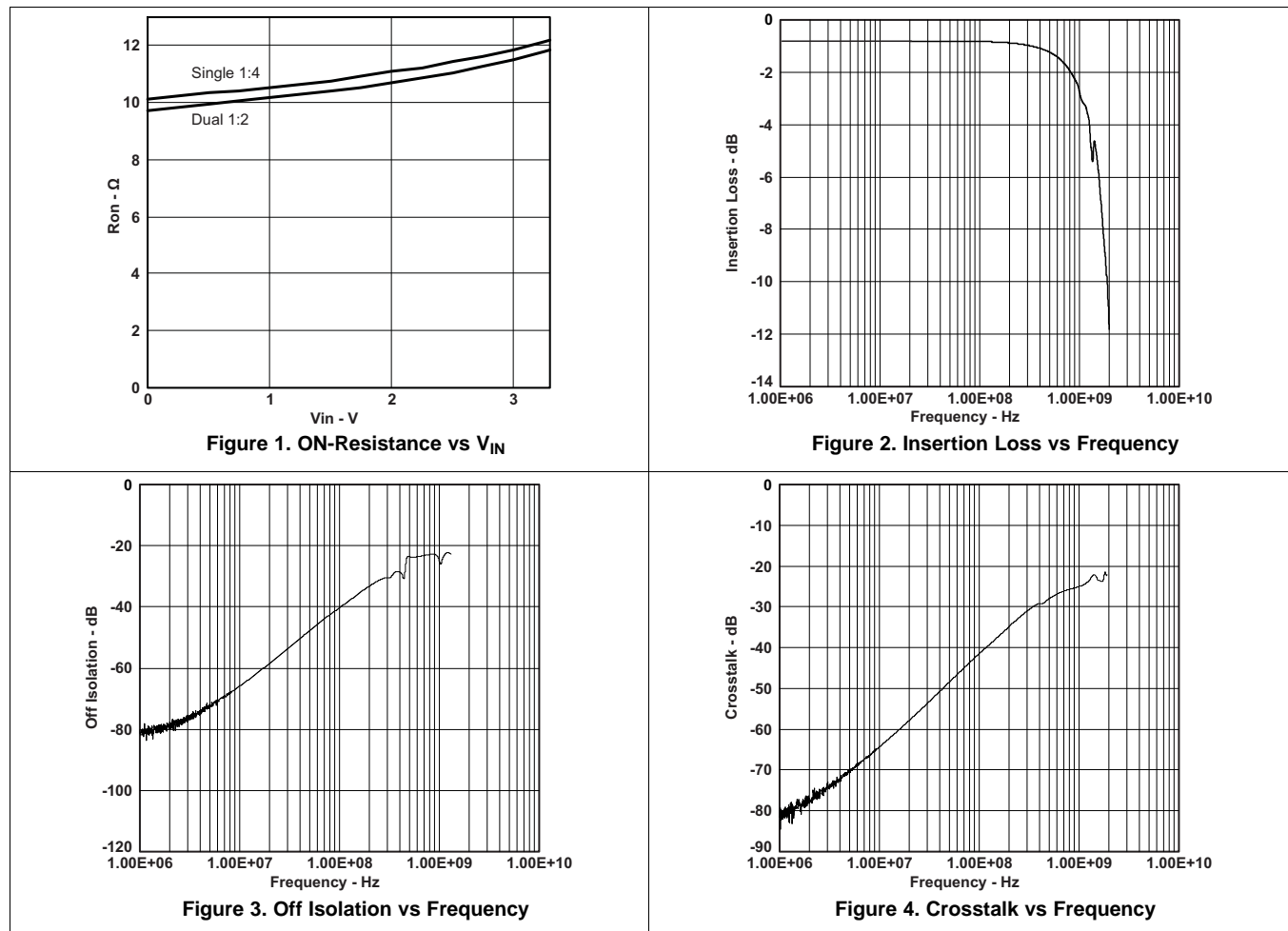

6.11.2 Fan-Out 1:2 Configurations

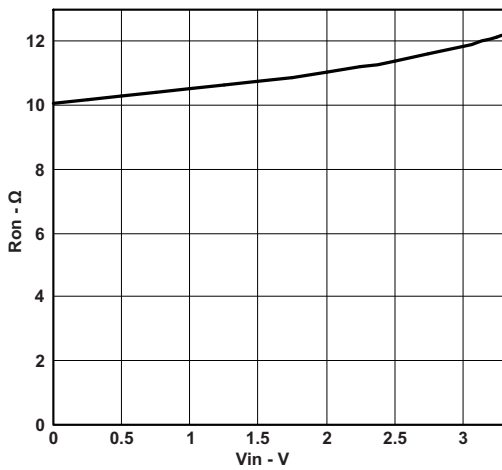

Figure 5. ON-Resistance vs V_{IN}

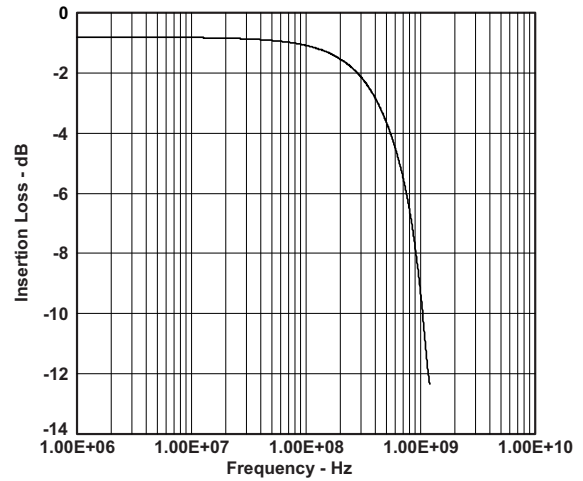

Figure 6. Insertion Loss vs Frequency

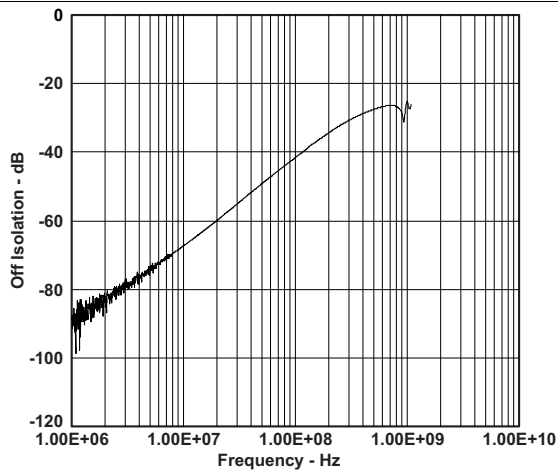

Figure 7. Off Isolation vs Frequency

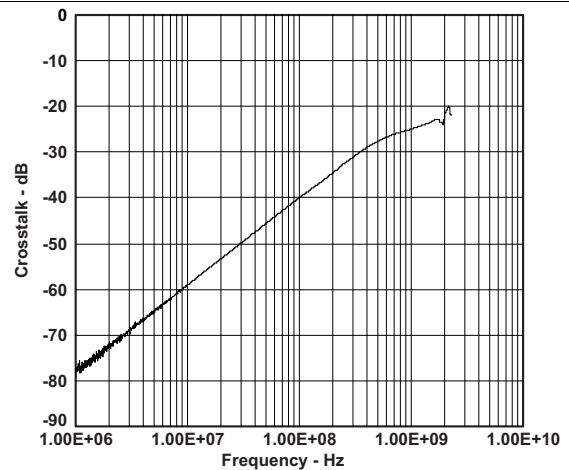
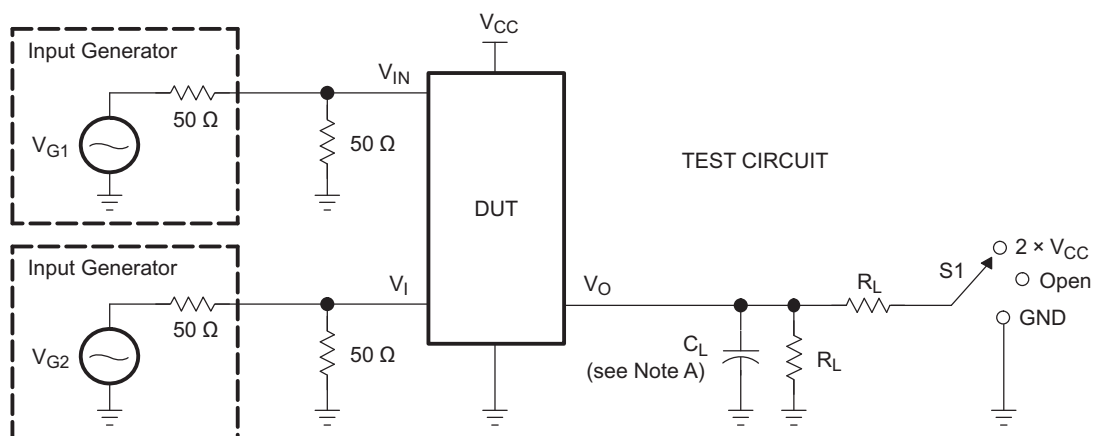
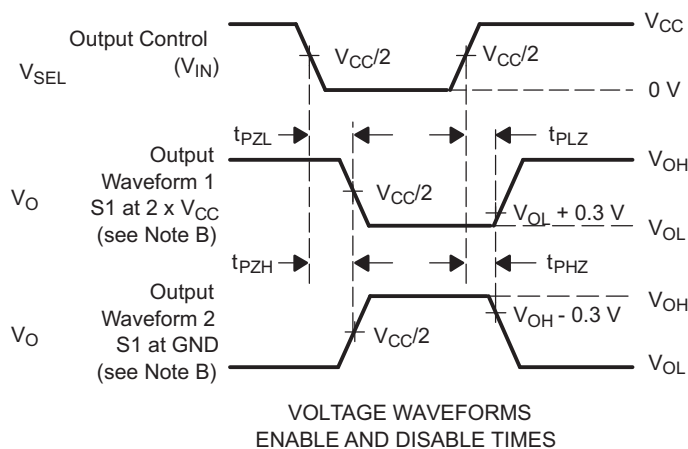

Figure 8. Crosstalk vs Frequency

7 Parameter Measurement Information



TEST	V _{CC}	S1	R _L	V _{in}	C _L	V _Δ
t _{PLZ} /t _{PZH}	3.3 V ± 0.3 V	2 × V _{CC}	50 Ω	GND	2 pF	0.3 V
t _{PHZ} /t _{PZH}	3.3 V ± 0.3 V	GND	50 Ω	V _{CC}	2 pF	0.3 V



- NOTES:
- A. C_L includes probe and jig capacitance.
 - B. Waveform 1 is for an output with internal conditions such that the output is low, except when disabled by the output control. Waveform 2 is for an output with internal conditions such that the output is high, except when disabled by the output control.
 - C. All input pulses are supplied by generators having the following characteristics: PRR ≤ 10 MHz, Z_O = 50 Ω, t_r ≤ 2.5 ns, t_f ≤ 2.5 ns.
 - D. The outputs are measured one at a time, with one transition per measurement.
 - E. t_{PLZ} and t_{PHZ} are the same as t_{OFF}.
 - F. t_{PZL} and t_{PZH} are the same as t_{ON}.

Figure 9. Test Circuit and Voltage Waveforms

Parameter Measurement Information (continued)

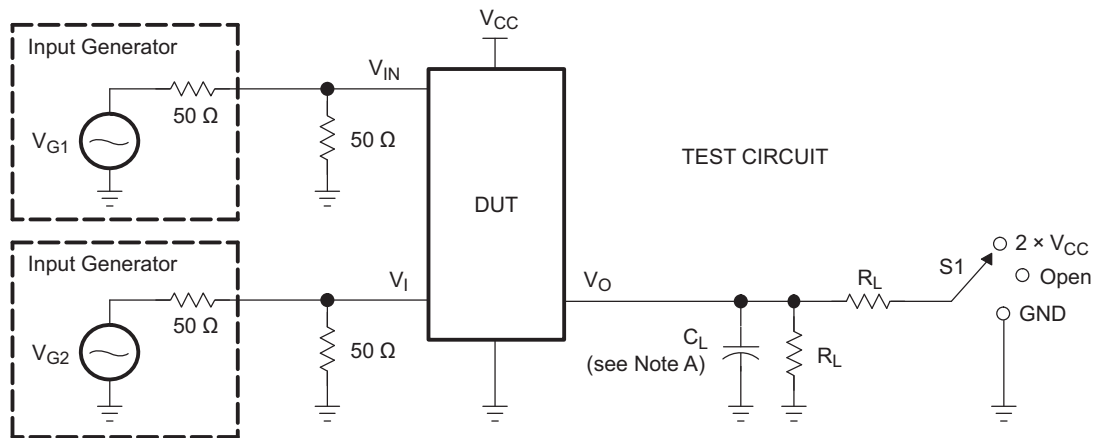

TEST	V _{CC}	S1	R _L	V _{in}	C _L
t _{sk(o)}	3.3 V ± 0.3 V	Open	50 Ω	V _{CC} or GND	2 pF
t _{sk(p)}	3.3 V ± 0.3 V	Open	50 Ω	V _{CC} or GND	2 pF

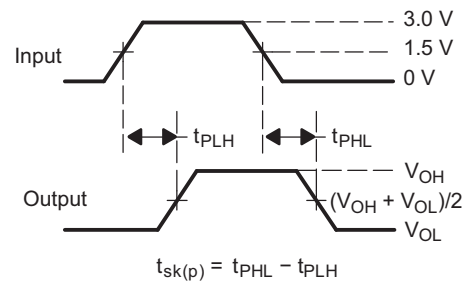
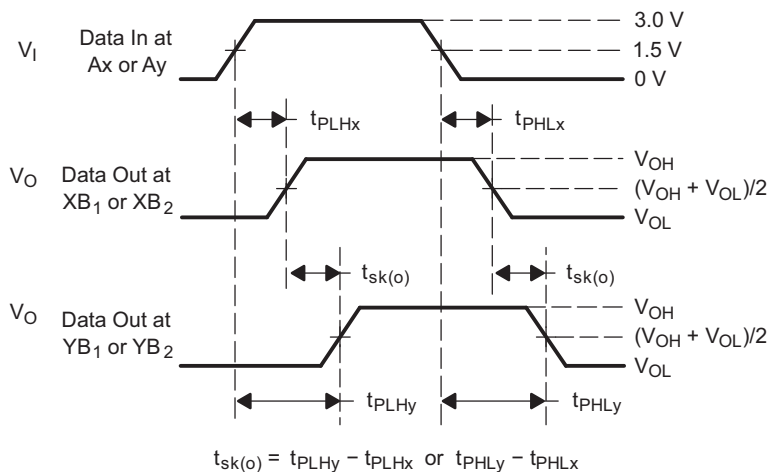

- NOTES: A. C_L includes probe and jig capacitance.
 B. Waveform 1 is for an output with internal conditions such that the output is low, except when disabled by the output control. Waveform 2 is for an output with internal conditions such that the output is high, except when disabled by the output control.
 C. All input pulses are supplied by generators having the following characteristics: PRR ≤ 10 MHz, Z_O = 50 Ω, t_r ≤ 2.5 ns, t_f ≤ 2.5 ns.
 D. The outputs are measured one at a time, with one transition per measurement.

Figure 10. Test Circuit and Voltage Waveforms

Parameter Measurement Information (continued)

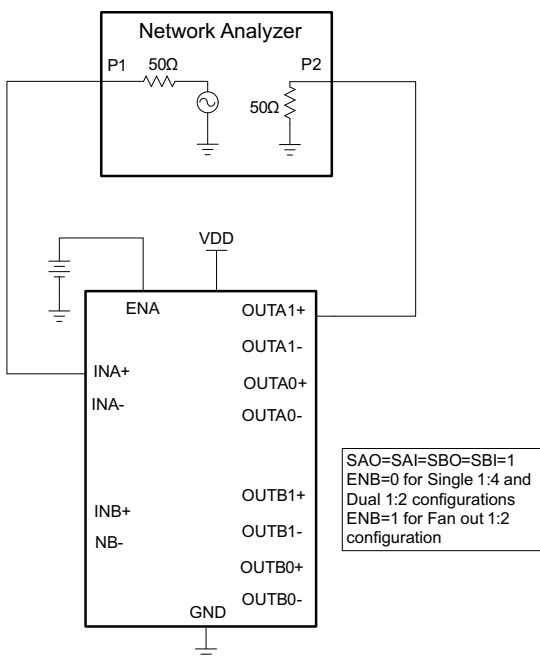

Figure 11. Frequency Response (BW)

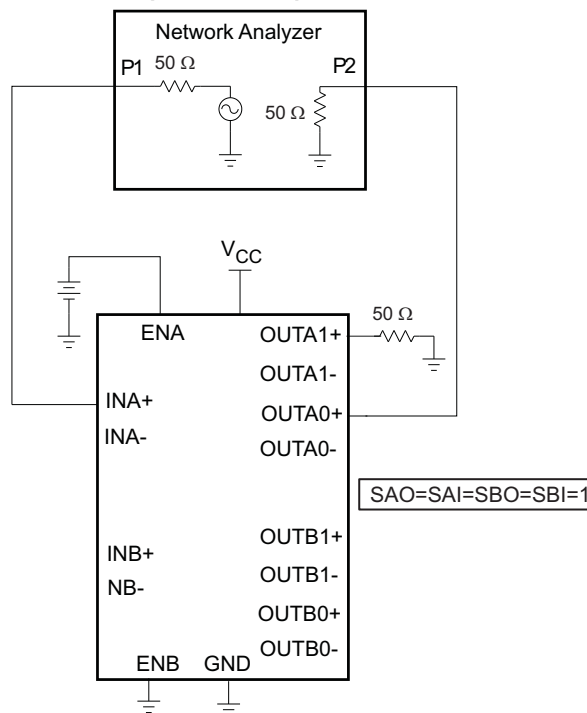

Figure 12. Off Isolation (O_{ISO})

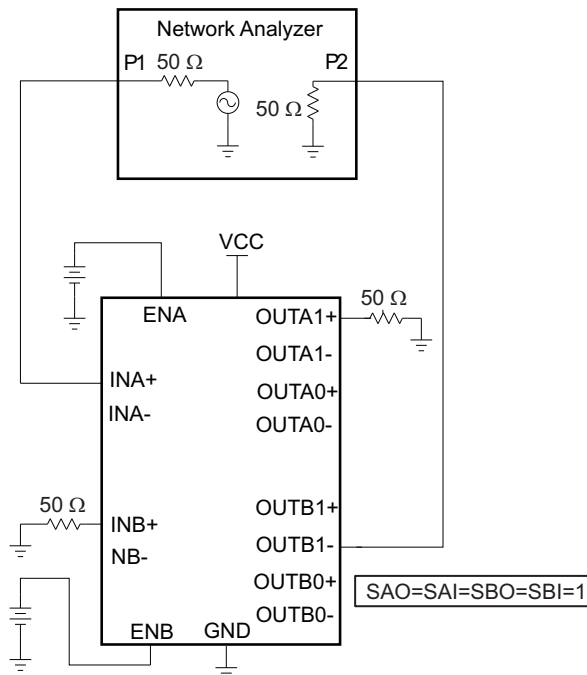

Figure 13. Crosstalk (X_{TALK})

8 Detailed Description

8.1 Overview

The TS3DS10224 is a 3-V, bidirectional, differential crosspoint, differential 1:4, 2-channel differential 1:2 multiplexer and demultiplexer, or fan-out switch for high-speed differential signal applications. The TS3DS10224 can route any input to any output creating a wide range of possible switching or multiplexing configurations. Differential crosspoint switching, differential 1:4 mux, or 2-channel differential 1:2 multiplexer and demultiplexer are commonly used configurations of the device. Additionally the TS3DS10224 can also be used to fan out a differential signal pair to two ports simultaneously (fan-out configuration). However, the BW performance is lower in this configuration.

8.2 Functional Block Diagram

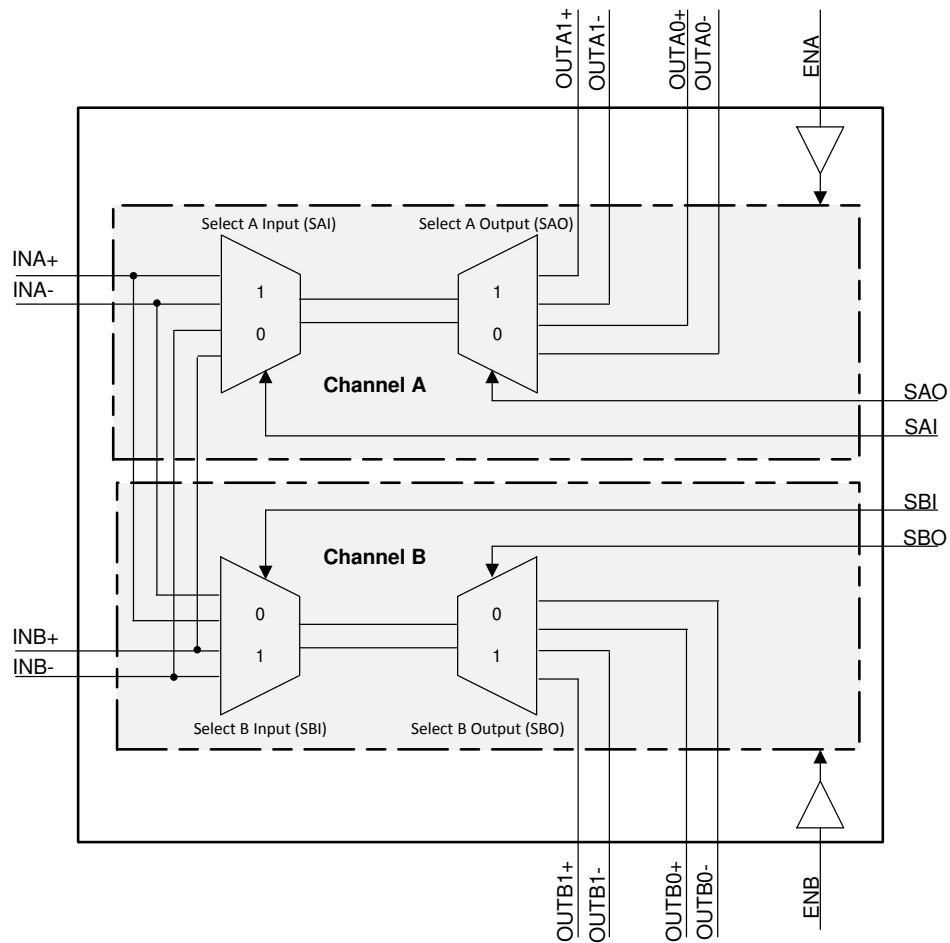

Copyright © 2016, Texas Instruments Incorporated

8.3 Feature Description

8.3.1 Fail-Safe Protection

I_{OFF} protection prevents current leakage in powered down state ($V_{CC} = 0\text{ V}$).

The TS3DS10224 device places the signal paths in a high-impedance state when the device is not powered. This isolates the data bus if the IC loses power on the supply pin.

8.4 Device Functional Modes

8.4.1 Enable and Disable

The TS3DS10224 has two enable pins (ENA and ENB). Setting these pins LOW disables the signal path and place them in a high-impedance (Hi-Z) state.

Table 1. Enable and Disable Function Table

ENA	ENB	INA	INB	OUTA0	OUTA1	OUTB0	OUTB1
0	0	Hi-Z	Hi-Z	Hi-Z	Hi-Z	Hi-Z	Hi-Z
0	1	Hi-Z	Enabled	Hi-Z	Hi-Z	Enabled	Enabled
1	0	Enabled	Hi-Z	Enabled	Enabled	Hi-Z	Hi-Z
1	1	Enabled	Enabled	Enabled	Enabled	Enabled	Enabled

8.4.2 Differential Crosspoint Switch

The TS3DS10224 can be configured as a differential crosspoint switch. Crosspoint switches are particularly helpful when traces have to cross in simplifying layouts, and when switching the top and bottom signals of the reversible connector in USB Type-C applications.

[Table 2](#) shows that the inputs INA and INB can be routed to OUTA or OUTB. This is accomplished by setting the Select A Output (SAO) and Select B Output (SBO) LOW and selecting which input goes to the output by toggling the Select A Input (SAI) and Select B Input (SBI) pins.

Table 2. Differential Crosspoint Switch Function Table

LOGIC CONTROL SETTING				SIGNAL ROUTING	
SAI	SBI	SAO	SBO	INA	INB
0	0	0	0	OUTB0	OUTA0
1	1	0	0	OUTA0	OUTB0

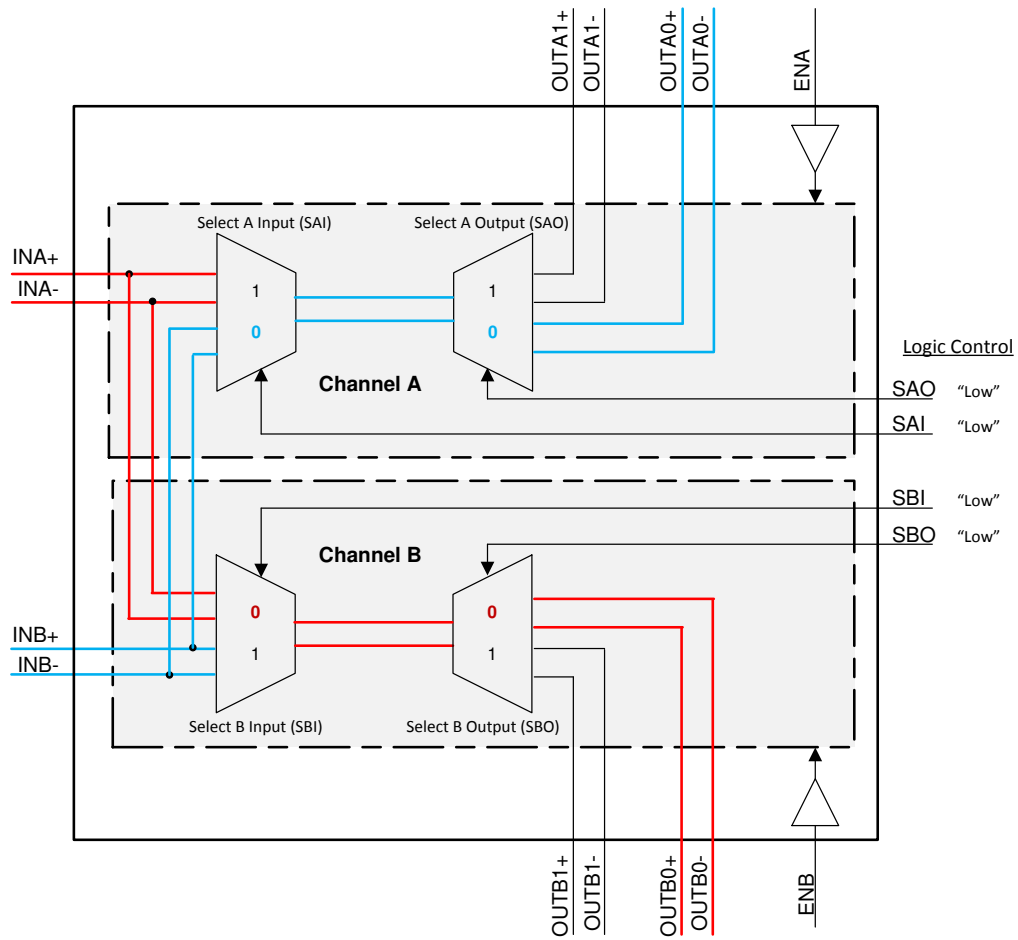

Copyright © 2016, Texas Instruments Incorporated

Figure 14. Differential Crosspoint Switch Block Diagram

8.4.3 2-Channel 1:2 Mux

The TS3DS10224 can be configured to be differential 2-channel 1:2 mux.

Table 3 shows that the inputs INA and INB can be routed to 2 different places. This is accomplished by setting the Select A Input (SAI) and Select B Input (SBI) HIGH and selecting an output by toggling the Select A Output (SAO) and Select B Output (SBO) pins.

Table 3. 2-Channel 1:2 Mux Function Table

LOGIC CONTROL SETTING				SIGNAL ROUTING	
SAI	SBI	SAO	SBO	INA	INB
1	1	0	0	OUTA0	OUTB0
1	1	0	1	OUTA0	OUTB1
1	1	1	0	OUTA1	OUTB0
1	1	1	1	OUTA1	OUTB1

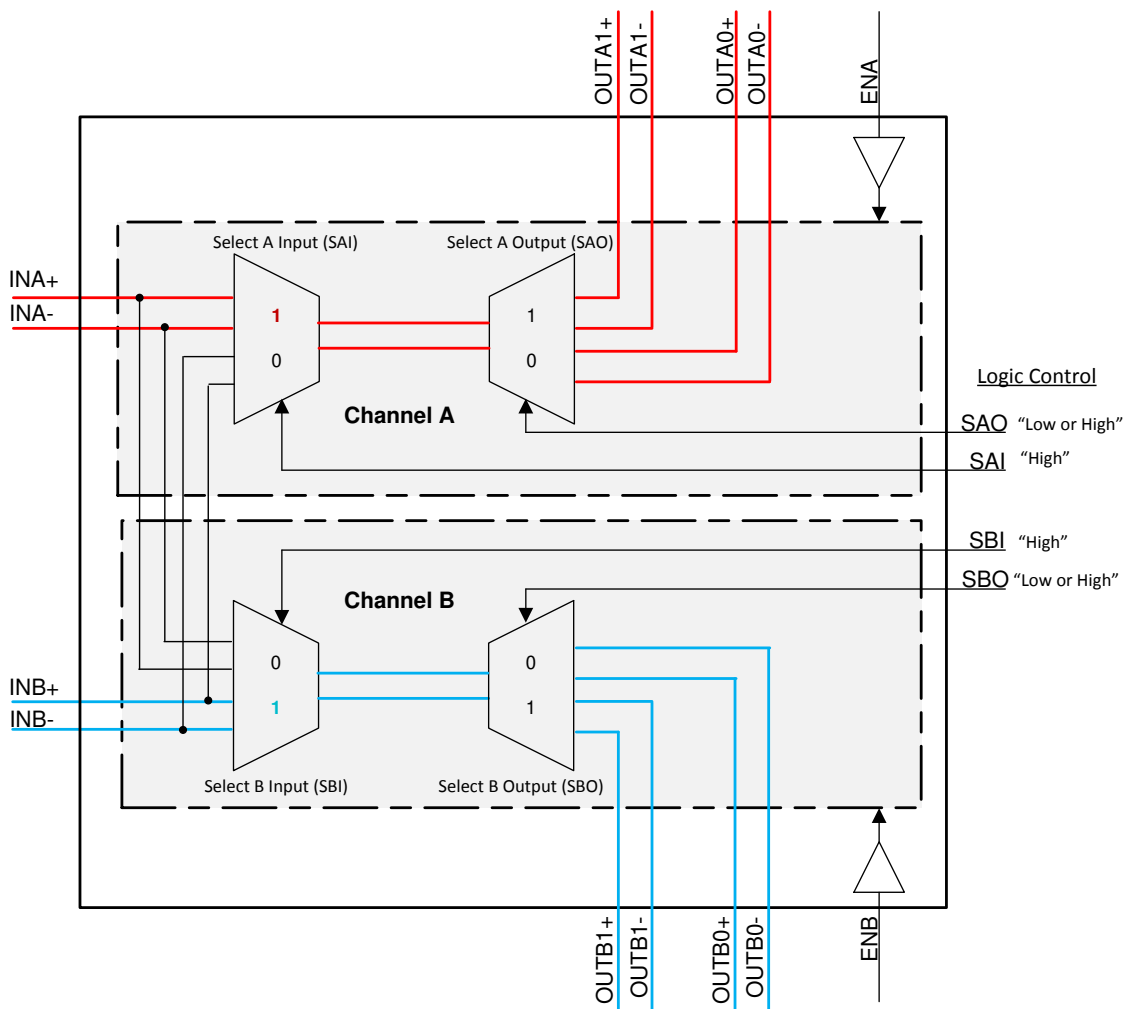

Copyright © 2016, Texas Instruments Incorporated

Figure 15. 2-Channel 1:2 Block Diagram

8.4.4 1-Channel 1:4 Mux

The TS3DS10224 can be configured as differential 1-channel 1:4 mux.

The truth table below shows that the inputs INA can be routed to 4 different places. This is accomplished by setting the Select A Input (SAI) and Select B Input (SBI) HIGH and selecting an output by toggling the Select A Output (SAO) and Select B Output (SBO) pins.

Unused pins INB+ and INB- must be left floating in this configuration.

Table 4. 1-Channel 1:4 Mux Function Table

LOGIC CONTROL SETTINGS				SIGNAL ROUTING	
SAI	SBI	SAO	SBO	INA	INB
1	1	0	—	OUTA0	—
1	1	1	—	OUTA1	—
0	0	—	0	OUTB0	—
0	0	—	1	OUTB1	—

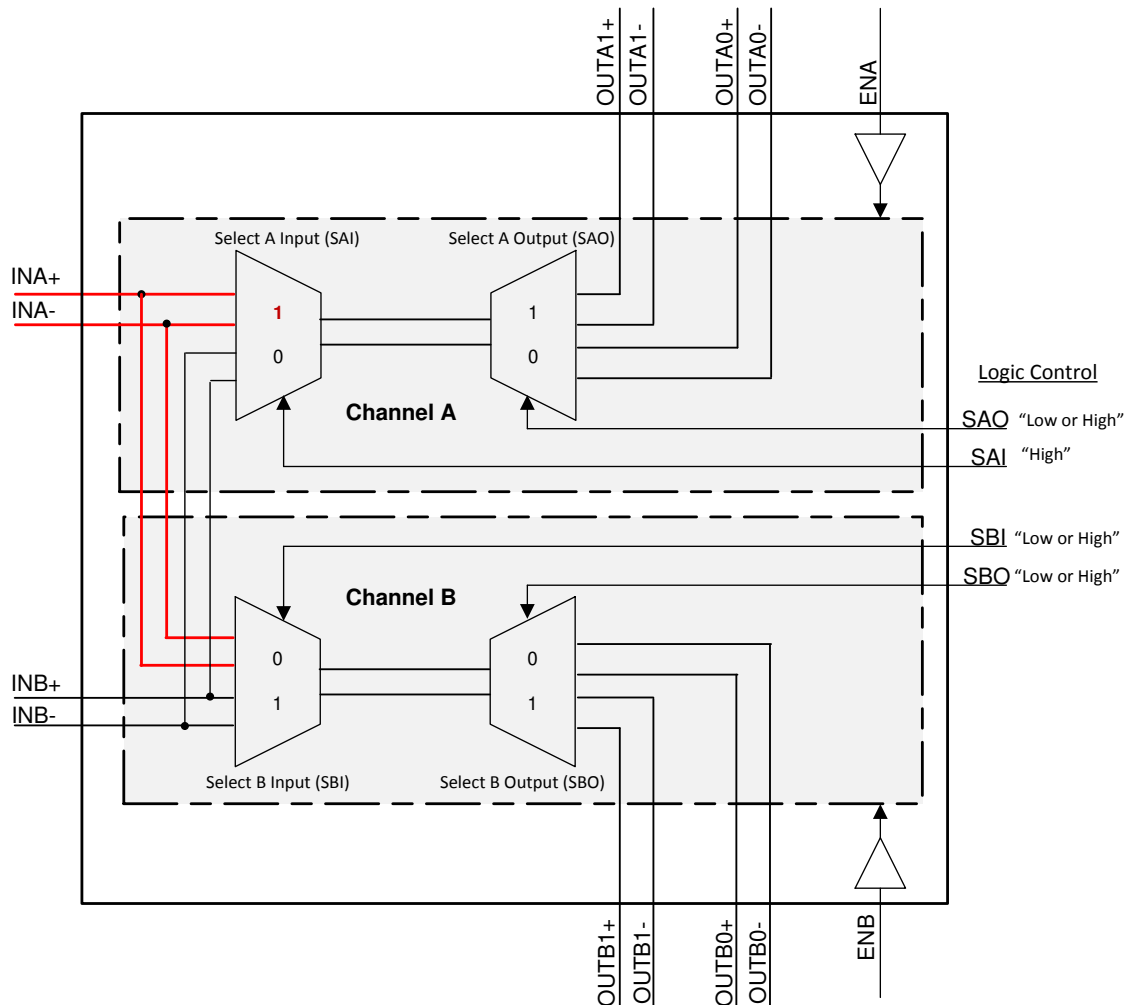

Copyright © 2016, Texas Instruments Incorporated

Figure 16. 1-Channel 1:4 Mux Functional Block Diagram

8.4.5 Fan-Out 1:2 Configuration

The TS3DS10224 can be configured in a differential fan-out 1:2 mux.

The truth table below shows that the inputs INA or INB can be routed to output A or output B simultaneously. This is accomplished by setting the Select A Input (SAI) and Select B Input (SBI) HIGH and selecting an output by toggling the Select A Output (SAO) and Select B Output (SBO) pins.

Unused pins INB+ and INB- must be left floating in this configuration.

Table 5. Fan-Out 1:2 Function Table

LOGIC CONTROL SETTINGS				SIGNAL ROUTING	
SAI	SBI	SAO	SBO	INA	INB
1	0	0	0	OUTA0 and OUTB0	—
1	0	0	1	OUTA0 and OUTB1	—
1	0	1	0	OUTA1 and OUTB0	—
1	0	1	1	OUTA1 and OUTB1	—

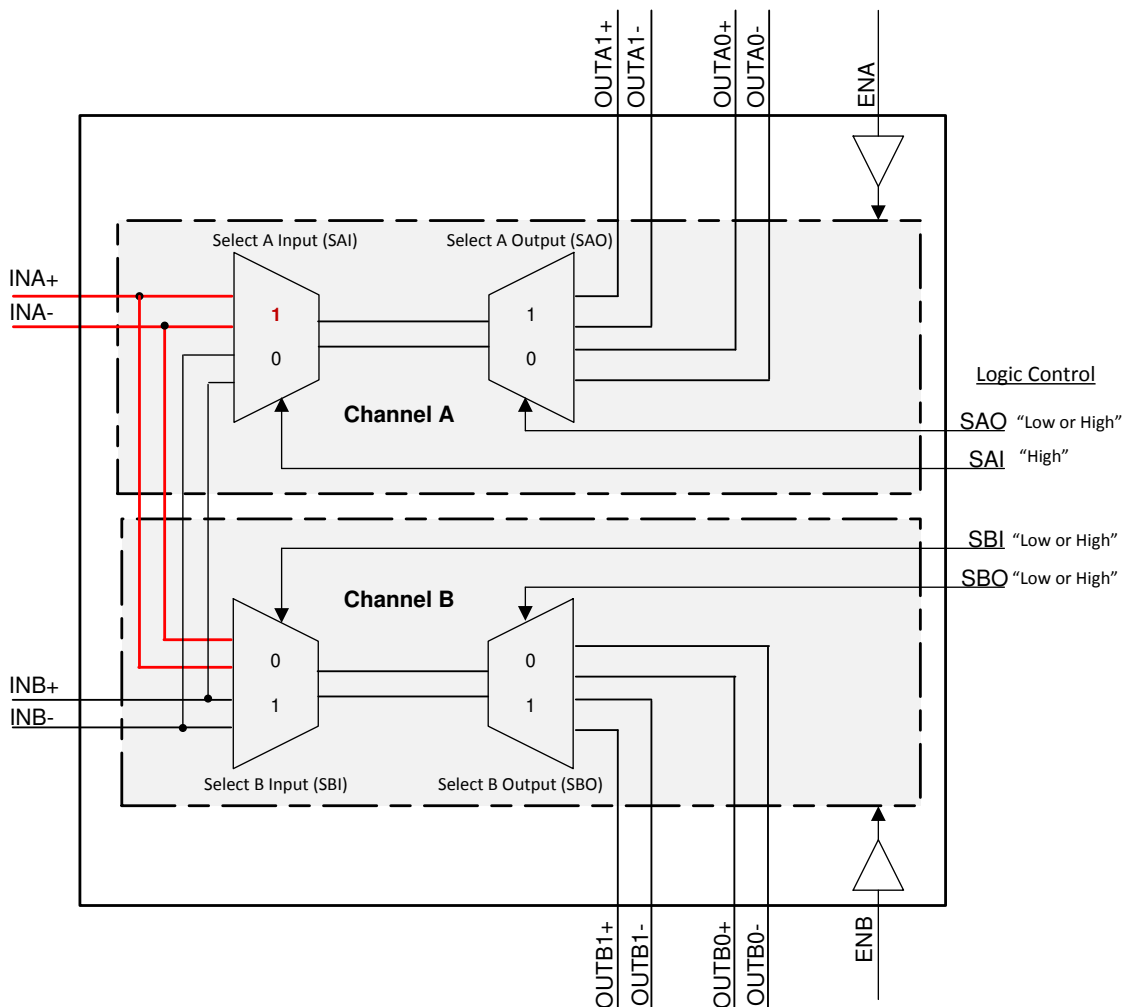

Copyright © 2016, Texas Instruments Incorporated

Figure 17. Fan-Out 1:2 Functional Block Diagram

Table 6.

SAI	SBI	SA0	SBO	OUTA0	OUTA1	OUTB0	OUTB1	FUNCTIONAL MODE
0	0	0	0	INB	—	INA	—	Crosspoint, 1-channel 1:4 mux
0	0	0	1	INB	—	—	INA	1-channel 1:4 mux
0	0	1	0	—	INB	INA	—	1-channel 1:4 mux
0	0	1	1	—	INB	—	INA	1-channel 1:4 mux
0	1	0	0	INB	—	INB	—	
0	1	0	1	INB	—	—	INB	
0	1	1	0	—	INB	INB	—	
0	1	1	1	—	INB	—	INB	
1	0	0	0	INA	—	INA	—	Fan-out 1:2 configuration
1	0	0	1	INA	—	—	INA	Fan-out 1:2 configuration
1	0	1	0	—	INA	INA	—	Fan-out 1:2 configuration
1	0	1	1	—	INA	—	INA	Fan-out 1:2 configuration
1	1	0	0	INA	—	INB	—	Crosspoint, 2-channel 1:2 mux, 1-channel 1:4 mux
1	1	0	1	INA	—	—	INB	2-channel 1:2 mux, 1-channel 1:4 mux
1	1	1	0	—	INA	INB	—	2-channel 1:2 mux, 1-channel 1:4 mux
1	1	1	1	—	INA	—	INB	2-channel 1:2 mux, 1-channel 1:4 mux

9 Application and Implementation

NOTE

Information in the following applications sections is not part of the TI component specification, and TI does not warrant its accuracy or completeness. TI's customers are responsible for determining suitability of components for their purposes. Customers should validate and test their design implementation to confirm system functionality.

9.1 Application Information

The TS3DS10224 device can be configured for a variety of applications which makes this a great utility device. The most unique feature of this device is the ability to operate as a differential crosspoint switch.

9.2 Typical Applications

9.2.1 1-Channel Differential 1:4 Mux

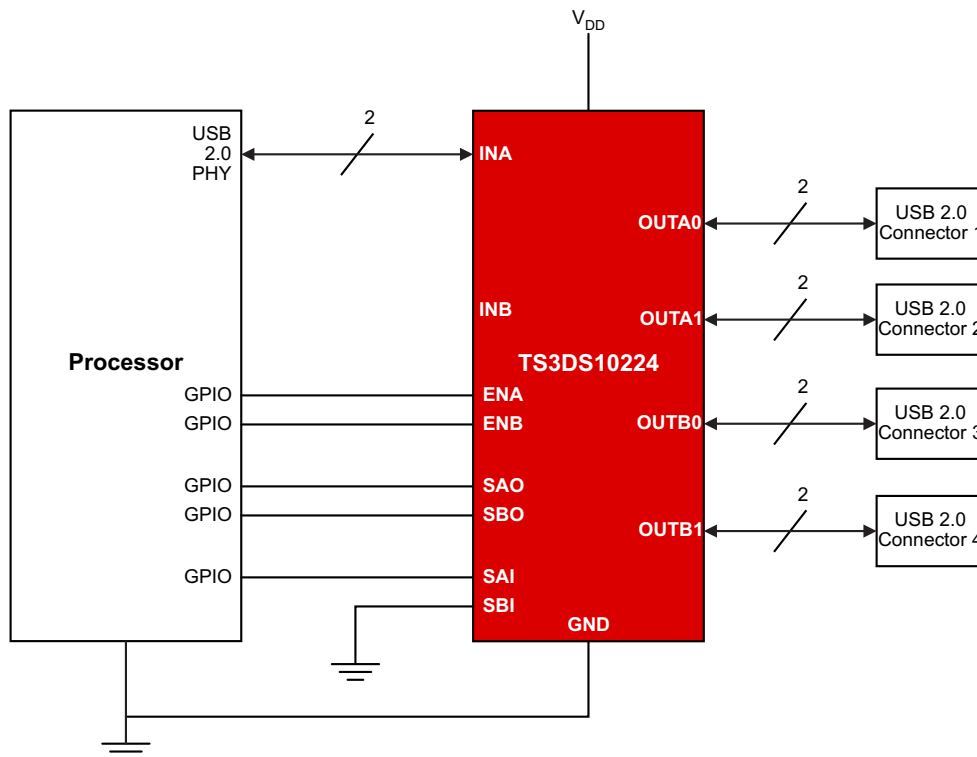

Copyright © 2016, Texas Instruments Incorporated

Figure 18. 1-Channel Differential 1:4 Mux Application

9.2.1.1 Design Requirements

TI recommends that the digital control pins SAI, SBI, SAO, and SBO be pulled up to V_{CC} or down to GND to avoid undesired switch positions that could result from a floating pin. Unused pins for the signal paths INA, INB, OUTAx, and OUTBx must be terminated with a 50- Ω resistor to ground to reduce signal reflections in high-speed applications.

The thermal pad may be left floating or connected to ground.

9.2.1.2 Detailed Design Procedure

The TS3DS10224 can be properly operated without any external components. TI recommends placing a bypass capacitor on the VCC pin.

Typical Applications (continued)

9.2.1.3 Application Curves

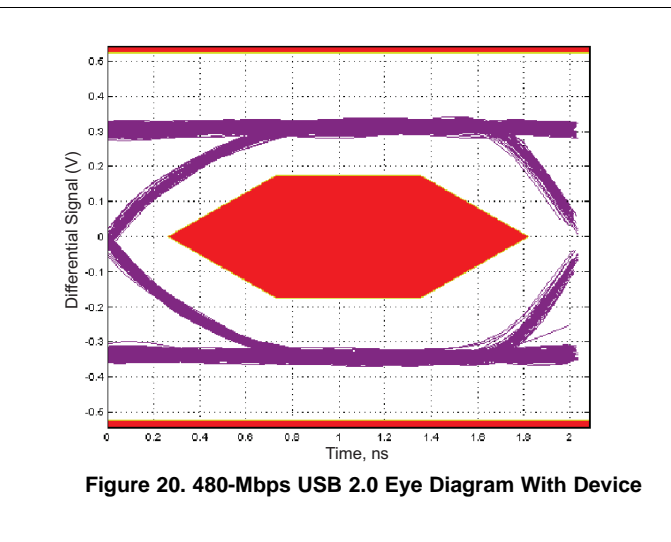
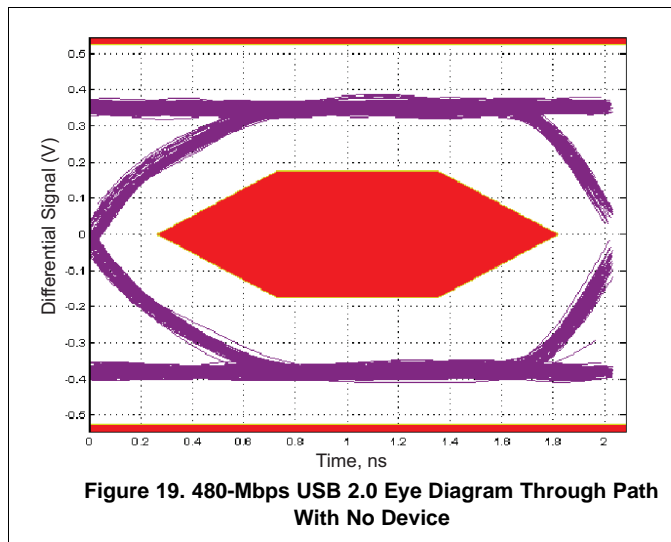

9.2.2 2-Channel Differential Crosspoint Switch

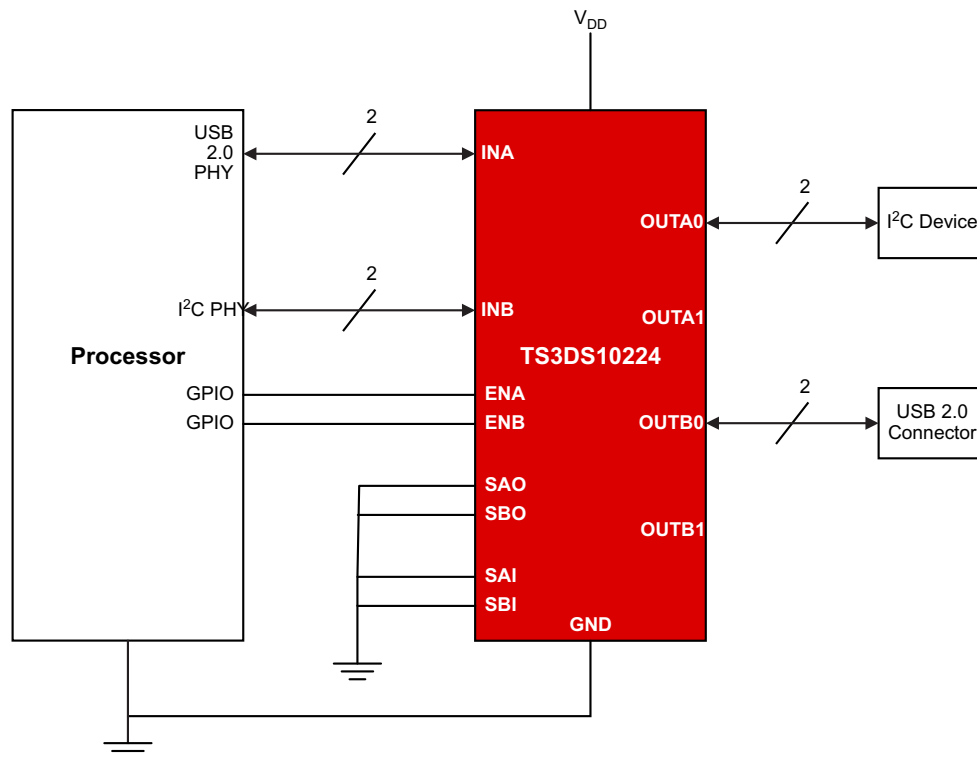

Copyright © 2016, Texas Instruments Incorporated

Figure 21. 2-Channel Differential Crosspoint Switch Schematic

Typical Applications (continued)

9.2.2.1 Design Requirements

TI recommends that the digital control pins SAI, SBI, SAO, and SBO be pulled up to V_{CC} or down to GND to avoid undesired switch positions that could result from a floating pin. Unused pins for the signal paths INA, INB, OUTAx, and OUTBx must be terminated with a 50- Ω resistor to ground to reduce signal reflections in high-speed applications.

9.2.3 Fan-Out Switch

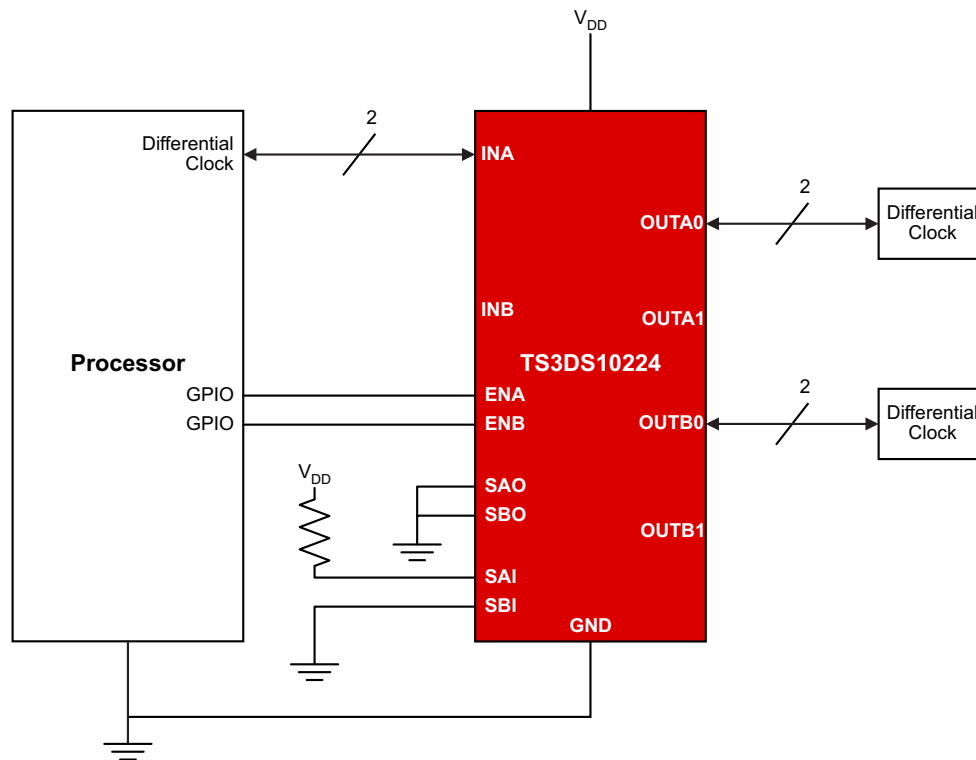

Copyright © 2016, Texas Instruments Incorporated

Figure 22. Fan-Out Switch Schematic

9.2.3.1 Design Requirements

TI recommends that the digital control pins SAI, SBI, SAO, and SBO be pulled up to V_{CC} or down to GND to avoid undesired switch positions that could result from the floating pin. Unused pins for the signal paths INA, INB, OUTAx, OUTBx must be terminated with a 50- Ω resistor to ground to reduce signal reflections in high-speed applications.

The bandwidth performance is lower in this application (500 MHz).

Typical Applications (continued)

9.2.4 2-Channel Differential 1:2 SPDT Switch

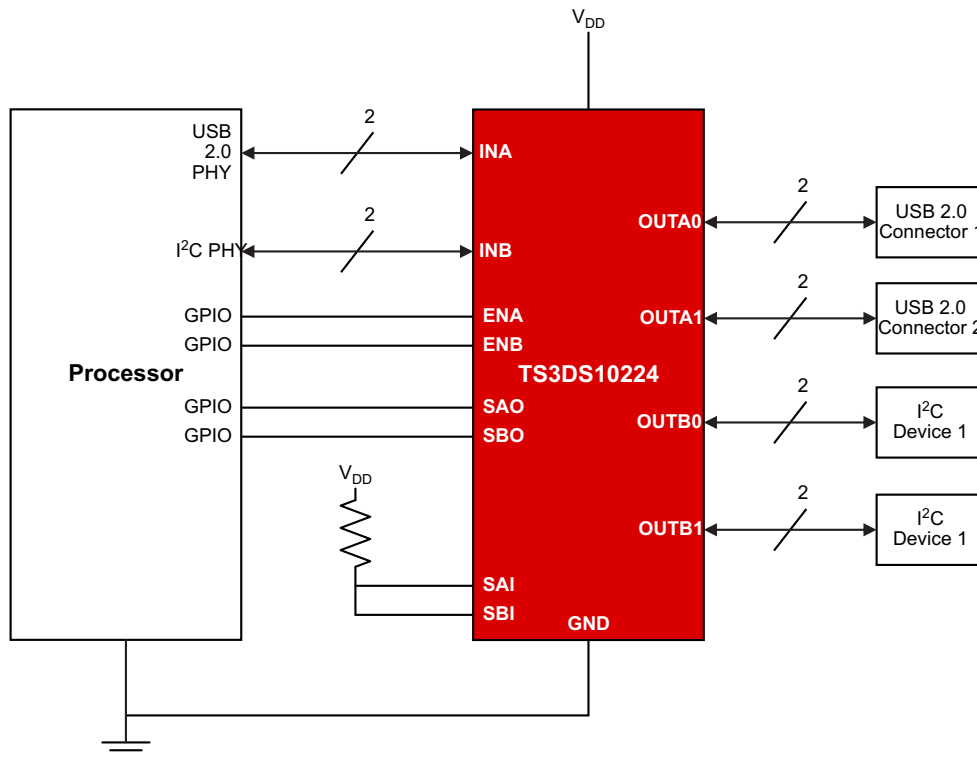

Copyright © 2016, Texas Instruments Incorporated

Figure 23. 2-Channel Differential 1:2 SPDT Switch Schematic

10 Power Supply Recommendations

Power to the device is supplied through the VCC pin and must be within the recommended operating voltage range. TI recommends a bypass capacitor be placed as close to the supply pin (VCC) as possible to help smooth out lower frequency noise and to provide better load regulation across the frequency spectrum.

11 Layout

11.1 Layout Guidelines

- The thermal pad may be left floating or connected to the ground plane
- Place supply-bypass capacitors as close to the VCC pin as possible and avoid placing the bypass capacitors near the positive and negative traces.
- The high-speed positive and negative traces must always be matched and the lengths must not exceed 4 inches; otherwise, the eye diagram performance may be degraded. In layout, the impedance of positive and negative traces must match the cable characteristic differential impedance for optimal performance.
- Route the high-speed signals using a minimum of vias and corners to reduce signal reflections and impedance changes. When a via must be used, increase the clearance size around it to minimize its capacitance. Each via introduces discontinuities in the signal's transmission line and increases the chance of picking up interference from the other layers of the board. Be careful when designing test points on twisted pair lines; through-hole pins are not recommended.
- When it becomes necessary to turn 90°, use two 45° turns or an arc instead of making a single 90° turn. This reduces reflections on the signal traces by minimizing impedance discontinuities.
- Do not route signal traces under or near crystals, oscillators, clock signal generators, switching regulators, mounting holes, magnetic devices, or ICs that use or duplicate clock signals.
- Avoid stubs on the high-speed signal traces because they cause signal reflections.
- Route all high-speed signal traces over continuous GND planes, with no interruptions.
- Avoid crossing over anti-etch, commonly found with plane splits.
- Due to high-frequency signal traces, TI recommends a printed-circuit board with at least four layers; two signal layers separated by a ground and power layer as shown in [Figure 24](#).

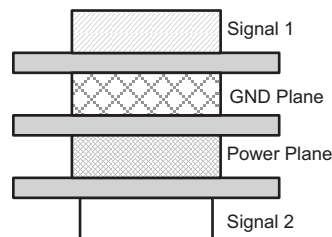

Figure 24. Four-Layer Board Stack-Up

The majority of signal traces must run on a single layer, preferably Signal 1. Immediately next to this layer must be the GND plane, which is solid with no cuts. Avoid running signal traces across a split in the ground or power plane. When running across split planes is unavoidable, sufficient decoupling must be used. Minimizing the number of signal vias reduces EMI by reducing inductance at high frequencies.

11.2 Layout Example

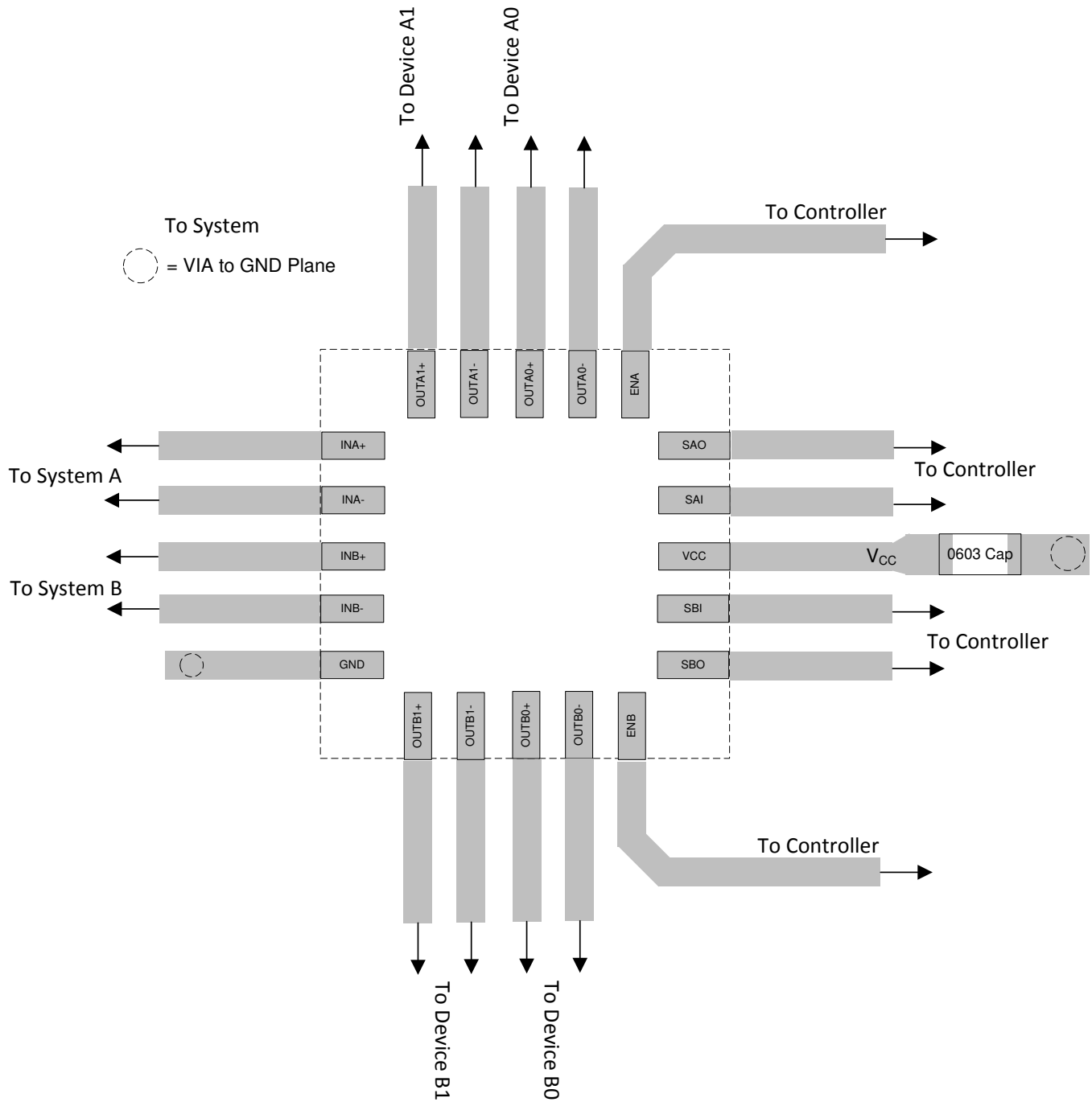

Figure 25. WQFN Layout Example

12 Device and Documentation Support

12.1 Documentation Support

12.1.1 Related Documentation

For related documentation see the following:

[Implications of Slow or Floating CMOS Inputs](#) (SCBA004)

12.2 Receiving Notification of Documentation Updates

To receive notification of documentation updates, navigate to the device product folder on ti.com. In the upper right corner, click on *Alert me* to register and receive a weekly digest of any product information that has changed. For change details, review the revision history included in any revised document.

12.3 Community Resources

TI E2E™ support forums are an engineer's go-to source for fast, verified answers and design help — straight from the experts. Search existing answers or ask your own question to get the quick design help you need.

Linked content is provided "AS IS" by the respective contributors. They do not constitute TI specifications and do not necessarily reflect TI's views; see TI's [Terms of Use](#).

12.4 Trademarks

E2E is a trademark of Texas Instruments.

All other trademarks are the property of their respective owners.

12.5 Electrostatic Discharge Caution



This integrated circuit can be damaged by ESD. Texas Instruments recommends that all integrated circuits be handled with appropriate precautions. Failure to observe proper handling and installation procedures can cause damage.

ESD damage can range from subtle performance degradation to complete device failure. Precision integrated circuits may be more susceptible to damage because very small parametric changes could cause the device not to meet its published specifications.

12.6 Glossary

[SLYZ022](#) — *TI Glossary*.

This glossary lists and explains terms, acronyms, and definitions.

13 Mechanical, Packaging, and Orderable Information

The following pages include mechanical, packaging, and orderable information. This information is the most current data available for the designated devices. This data is subject to change without notice and revision of this document. For browser-based versions of this data sheet, refer to the left-hand navigation.

PACKAGING INFORMATION

Orderable Device	Status (1)	Package Type	Package Drawing	Pins	Package Qty	Eco Plan (2)	Lead finish/ Ball material (6)	MSL Peak Temp (3)	Op Temp (°C)	Device Marking (4/5)	Samples
TS3DS10224RUKR	ACTIVE	WQFN	RUK	20	3000	RoHS & Green	NIPDAU	Level-2-260C-1 YEAR	-40 to 85	ZTB	Samples

(1) The marketing status values are defined as follows:

ACTIVE: Product device recommended for new designs.

LIFEBUY: TI has announced that the device will be discontinued, and a lifetime-buy period is in effect.

NRND: Not recommended for new designs. Device is in production to support existing customers, but TI does not recommend using this part in a new design.

PREVIEW: Device has been announced but is not in production. Samples may or may not be available.

OBSELETE: TI has discontinued the production of the device.

(2) **RoHS:** TI defines "RoHS" to mean semiconductor products that are compliant with the current EU RoHS requirements for all 10 RoHS substances, including the requirement that RoHS substance do not exceed 0.1% by weight in homogeneous materials. Where designed to be soldered at high temperatures, "RoHS" products are suitable for use in specified lead-free processes. TI may reference these types of products as "Pb-Free".

RoHS Exempt: TI defines "RoHS Exempt" to mean products that contain lead but are compliant with EU RoHS pursuant to a specific EU RoHS exemption.

Green: TI defines "Green" to mean the content of Chlorine (Cl) and Bromine (Br) based flame retardants meet JS709B low halogen requirements of <=1000ppm threshold. Antimony trioxide based flame retardants must also meet the <=1000ppm threshold requirement.

(3) MSL, Peak Temp. - The Moisture Sensitivity Level rating according to the JEDEC industry standard classifications, and peak solder temperature.

(4) There may be additional marking, which relates to the logo, the lot trace code information, or the environmental category on the device.

(5) Multiple Device Markings will be inside parentheses. Only one Device Marking contained in parentheses and separated by a "-" will appear on a device. If a line is indented then it is a continuation of the previous line and the two combined represent the entire Device Marking for that device.

(6) Lead finish/Ball material - Orderable Devices may have multiple material finish options. Finish options are separated by a vertical ruled line. Lead finish/Ball material values may wrap to two lines if the finish value exceeds the maximum column width.

Important Information and Disclaimer:The information provided on this page represents TI's knowledge and belief as of the date that it is provided. TI bases its knowledge and belief on information provided by third parties, and makes no representation or warranty as to the accuracy of such information. Efforts are underway to better integrate information from third parties. TI has taken and continues to take reasonable steps to provide representative and accurate information but may not have conducted destructive testing or chemical analysis on incoming materials and chemicals. TI and TI suppliers consider certain information to be proprietary, and thus CAS numbers and other limited information may not be available for release.

In no event shall TI's liability arising out of such information exceed the total purchase price of the TI part(s) at issue in this document sold by TI to Customer on an annual basis.

TAPE AND REEL INFORMATION

QUADRANT ASSIGNMENTS FOR PIN 1 ORIENTATION IN TAPE

*All dimensions are nominal

Device	Package Type	Package Drawing	Pins	SPQ	Reel Diameter (mm)	Reel Width W1 (mm)	A0 (mm)	B0 (mm)	K0 (mm)	P1 (mm)	W (mm)	Pin1 Quadrant
TS3DS10224RUKR	WQFN	RUK	20	3000	330.0	12.4	3.3	3.3	1.1	8.0	12.0	Q2

TAPE AND REEL BOX DIMENSIONS

*All dimensions are nominal

Device	Package Type	Package Drawing	Pins	SPQ	Length (mm)	Width (mm)	Height (mm)
TS3DS10224RUKR	WQFN	RUK	20	3000	346.0	346.0	33.0

GENERIC PACKAGE VIEW

RUK 20

WQFN - 0.8 mm max height

3 x 3, 0.4 mm pitch

PLASTIC QUAD FLATPACK - NO LEAD

This image is a representation of the package family, actual package may vary.
Refer to the product data sheet for package details.

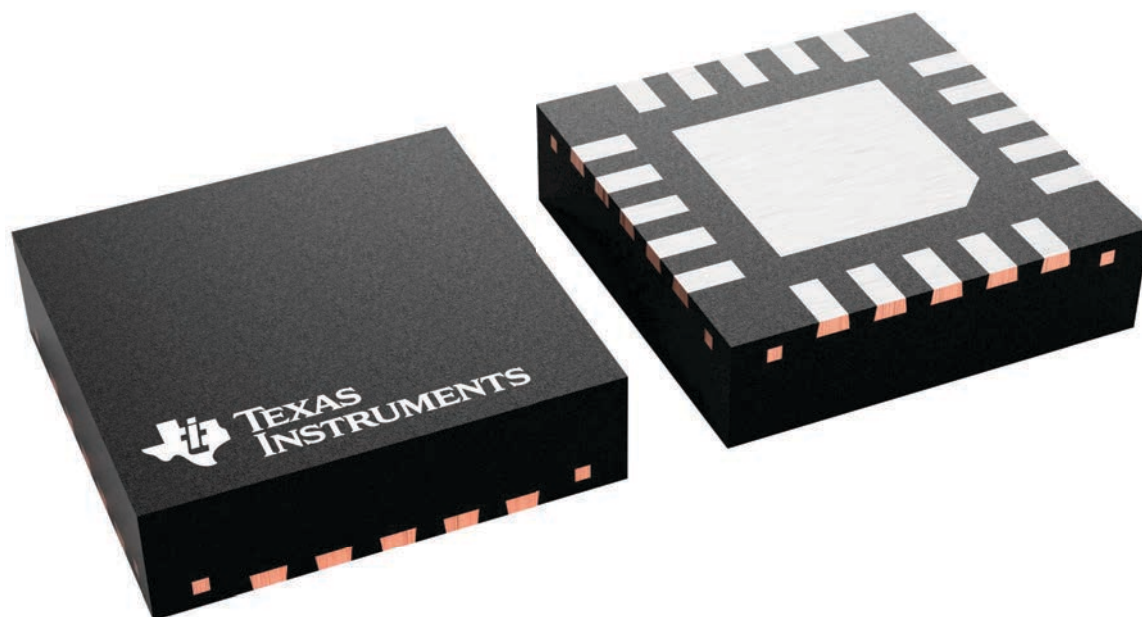

4229651/A

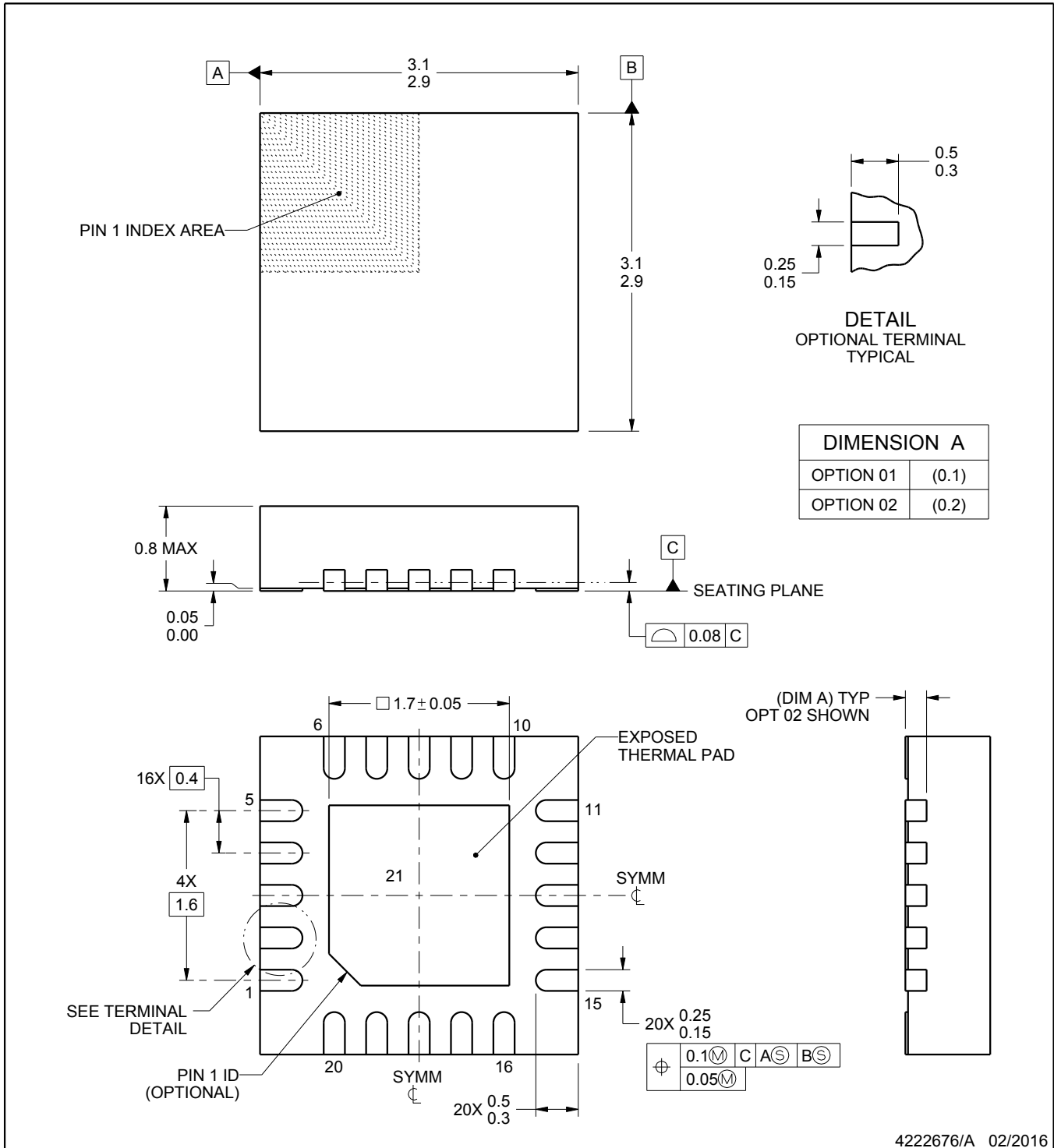
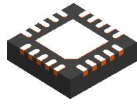

4222676/A 02/2016

NOTES:

1. All linear dimensions are in millimeters. Any dimensions in parenthesis are for reference only. Dimensioning and tolerancing per ASME Y14.5M.
2. This drawing is subject to change without notice.
3. The package thermal pad must be soldered to the printed circuit board for thermal and mechanical performance.

EXAMPLE BOARD LAYOUT

RUK0020B

WQFN - 0.8 mm max height

PLASTIC QUAD FLATPACK - NO LEAD

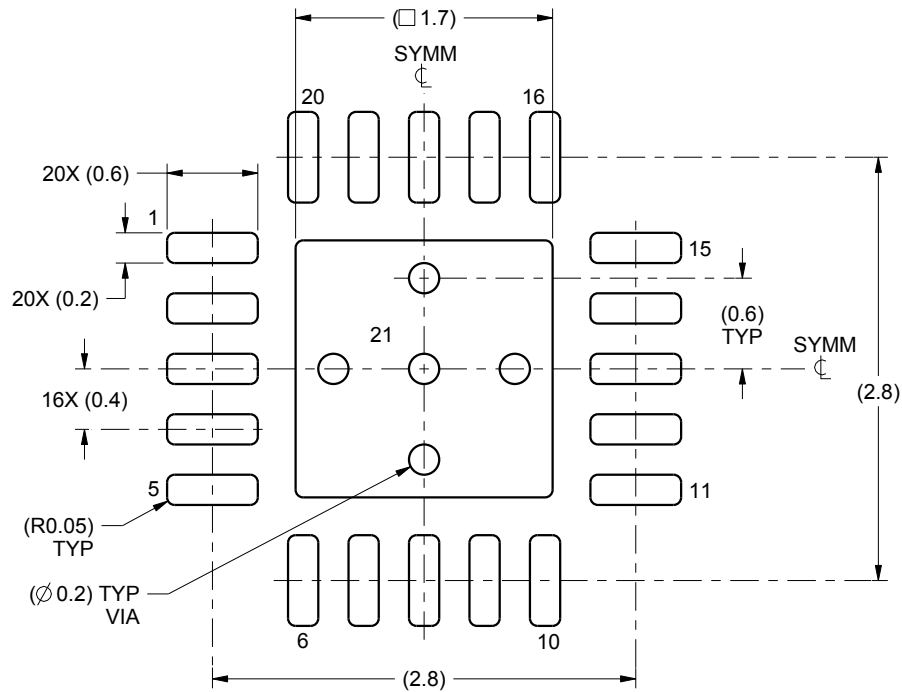

LAND PATTERN EXAMPLE
SCALE:20X

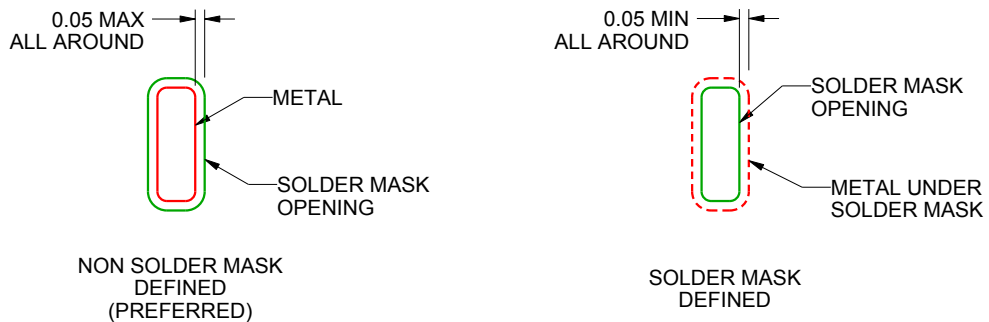

SOLDER MASK DETAILS

4222676/A 02/2016

NOTES: (continued)

4. This package is designed to be soldered to a thermal pad on the board. For more information, see Texas Instruments literature number SLUA271 (www.ti.com/lit/slua271).
5. Vias are optional depending on application, refer to device data sheet. If any vias are implemented, refer to their locations shown on this view. It is recommended that vias under paste be filled, plugged or tented.

EXAMPLE STENCIL DESIGN

RUK0020B

WQFN - 0.8 mm max height

PLASTIC QUAD FLATPACK - NO LEAD

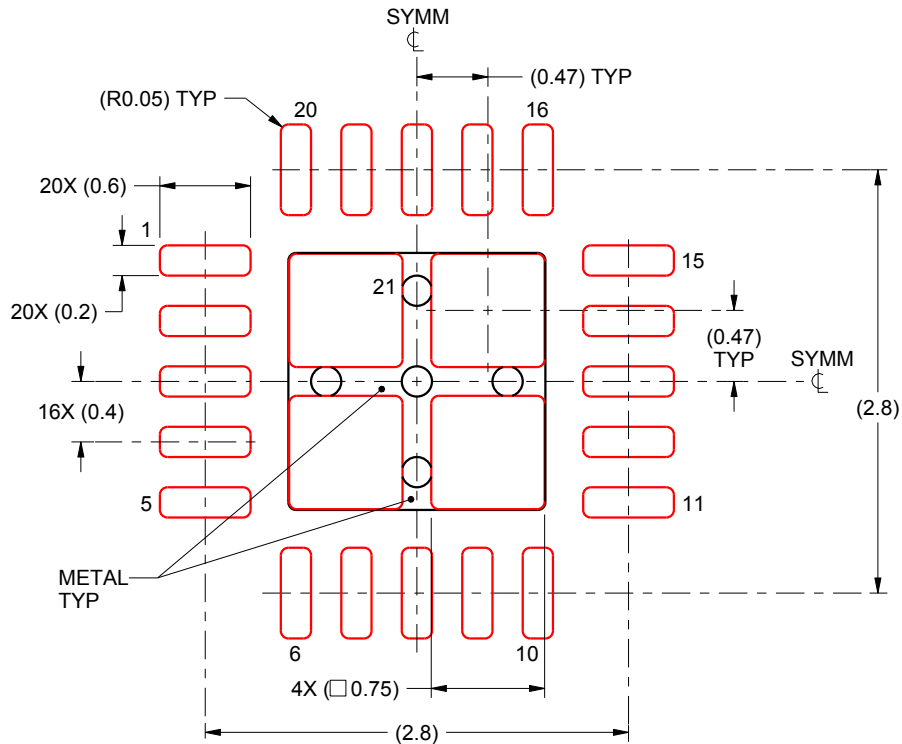

SOLDER PASTE EXAMPLE BASED ON 0.1 mm THICK STENCIL

EXPOSED PAD 21:
78% PRINTED SOLDER COVERAGE BY AREA UNDER PACKAGE
SCALE:20X

4222676/A 02/2016

NOTES: (continued)

6. Laser cutting apertures with trapezoidal walls and rounded corners may offer better paste release. IPC-7525 may have alternate design recommendations.

IMPORTANT NOTICE AND DISCLAIMER

TI PROVIDES TECHNICAL AND RELIABILITY DATA (INCLUDING DATA SHEETS), DESIGN RESOURCES (INCLUDING REFERENCE DESIGNS), APPLICATION OR OTHER DESIGN ADVICE, WEB TOOLS, SAFETY INFORMATION, AND OTHER RESOURCES "AS IS" AND WITH ALL FAULTS, AND DISCLAIMS ALL WARRANTIES, EXPRESS AND IMPLIED, INCLUDING WITHOUT LIMITATION ANY IMPLIED WARRANTIES OF MERCHANTABILITY, FITNESS FOR A PARTICULAR PURPOSE OR NON-INFRINGEMENT OF THIRD PARTY INTELLECTUAL PROPERTY RIGHTS.

These resources are intended for skilled developers designing with TI products. You are solely responsible for (1) selecting the appropriate TI products for your application, (2) designing, validating and testing your application, and (3) ensuring your application meets applicable standards, and any other safety, security, regulatory or other requirements.

These resources are subject to change without notice. TI grants you permission to use these resources only for development of an application that uses the TI products described in the resource. Other reproduction and display of these resources is prohibited. No license is granted to any other TI intellectual property right or to any third party intellectual property right. TI disclaims responsibility for, and you will fully indemnify TI and its representatives against, any claims, damages, costs, losses, and liabilities arising out of your use of these resources.

TI's products are provided subject to [TI's Terms of Sale](#) or other applicable terms available either on [ti.com](https://www.ti.com) or provided in conjunction with such TI products. TI's provision of these resources does not expand or otherwise alter TI's applicable warranties or warranty disclaimers for TI products.

TI objects to and rejects any additional or different terms you may have proposed.

Mailing Address: Texas Instruments, Post Office Box 655303, Dallas, Texas 75265
Copyright © 2023, Texas Instruments Incorporated

Looking for pricing, stock, or lifecycle information?

Click below to explore more details on WIN SOURCE:

 [View TS3DS10224RUKR on WIN SOURCE](#)

 [Texas Instruments](#) Information

Optimize Your Supply Chain with WIN SOURCE Solutions

-  Global Sourcing Solution
-  Obsolete Management
-  Cost Control Management
-  Shortage Management
-  Alternative Solution
-  Excess Inventory Management