



**THE DATASHEET OF  
TS3A5223RSWR**



## TS3A5223 0.45 $\Omega$ 2-Channel SPDT Bidirectional Analog Switch

### 1 Features

- Low ON Resistance Switches
  - 0.45  $\Omega$  (Typical) at 3.6 V
  - 0.85  $\Omega$  (Typical) at 1.8 V
- Wide Supply Range: 1.65 V to 3.6 V
- 1.0 V Compatible Logic Interface
- High Switch Bandwidth 80 MHz
- 0.01% THD Across Entire Band
- Specified min Break-before-make
- Bi-directional Switching
- –75 dB Channel-to-Channel Crosstalk
- –70 dB Channel-to-Channel OFF Isolation of Very Low Power Dissipation and Leakage Currents
- Very Small QFN-10 Package: 1.8 mm x 1.4 mm
- ESD Protection on all Pins
  - 2 kV HBM, 500 V CDM

### 2 Applications

- Portable Electronics
- Smartphones, Tablets
- Home Electronics
- Wireline Communication

### 3 Description

The TS3A5223 is a high-speed 2-channel analog switch with break-before-make and bi-directional signal switching capability. The TS3A5223 can be used as a dual 2:1 multiplexer or a 1:2 dual demultiplexer.

The TS3A5223 offers very low ON resistance, very low THD, channel-to-channel crosstalk and very high OFF isolation. These features make TS3A5223 suitable for application in Audio signal routing and switching applications.

The TS3A5223 control logic supports 1 V – 3.6 V CMOS logic levels. The logic interface allows direct interface with a wide range of CPUs and microcontrollers without increasing the current drawn from supply ( $I_{CC}$ ) and thus lowering power consumption.

#### Device Information<sup>(1)</sup>

PART NUMBER	PACKAGE	BODY SIZE (NOM)
TS3A5223	$\mu$ QFN (10)	1.80 mm x 1.40 mm

(1) For all available packages, see the orderable addendum at the end of the data sheet.

#### Functional Diagram

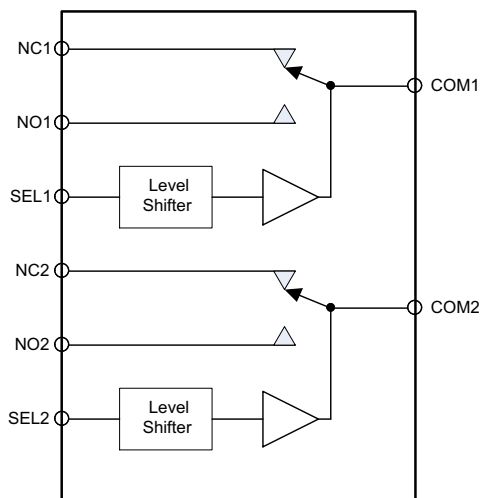

Copyright © 2017, Texas Instruments Incorporated



## Table of Contents

<b>1 Features</b> .....	<b>1</b>	8.4 Device Functional Modes.....	<b>11</b>
<b>2 Applications</b> .....	<b>1</b>	<b>9 Application and Implementation</b> .....	<b>12</b>
<b>3 Description</b> .....	<b>1</b>	9.1 Application Information.....	<b>12</b>
<b>4 Revision History</b> .....	<b>2</b>	9.2 Typical Application .....	<b>12</b>
<b>5 Pin Configuration and Functions</b> .....	<b>3</b>	<b>10 Power Supply Recommendations</b> .....	<b>13</b>
<b>6 Specifications</b> .....	<b>4</b>	<b>11 Layout</b> .....	<b>14</b>
6.1 Absolute Maximum Ratings .....	4	11.1 Layout Guidelines .....	14
6.2 ESD Ratings .....	4	11.2 Layout Example .....	14
6.3 Recommended Operating Conditions.....	4	<b>12 Device and Documentation Support</b> .....	<b>15</b>
6.4 Thermal Information .....	4	12.1 Documentation Support .....	15
6.5 Electrical Characteristics.....	5	12.2 Receiving Notification of Documentation Updates	15
6.6 Typical Characteristics .....	6	12.3 Community Resources.....	15
<b>7 Parameter Measurement Information</b> .....	<b>7</b>	12.4 Trademarks .....	15
<b>8 Detailed Description</b> .....	<b>10</b>	12.5 Electrostatic Discharge Caution.....	15
8.1 Overview .....	10	12.6 Glossary .....	15
8.2 Functional Block Diagram .....	10	<b>13 Mechanical, Packaging, and Orderable</b>	<b>15</b>
8.3 Feature Description.....	10	<b>Information</b> .....	<b>15</b>

## 4 Revision History

NOTE: Page numbers for previous revisions may differ from page numbers in the current version.

<b>Changes from Revision A (February 2013) to Revision B</b>	<b>Page</b>
• Added the <i>Device Information</i> table, <i>ESD Ratings</i> table, <i>Thermal Information</i> table, <i>Feature Description</i> section, <i>Device Functional Modes</i> , <i>Application and Implementation</i> section, <i>Power Supply Recommendations</i> section, <i>Layout</i> section, <i>Device and Documentation Support</i> section, and <i>Mechanical, Packaging, and Orderable Information</i> section .....	1
• Changed the $V_{Max}$ MAX value From: 3.6 V To: $V_{CC}$ in the <i>Recommended Operating Conditions</i> table .....	4
• Deleted: "dt/dv, SEL pin Input rise and fall time limit" from the <i>Recommended Operating Conditions</i> table.....	4
• Deleted the <i>Dissipation Ratings</i> table.....	4

<b>Changes from Original (January 2013) to Revision A</b>	<b>Page</b>
• Changed the device status From: Preview To: Production .....	1

## 5 Pin Configuration and Functions

**RSW Package  
10 Pin UQFN  
Top View**

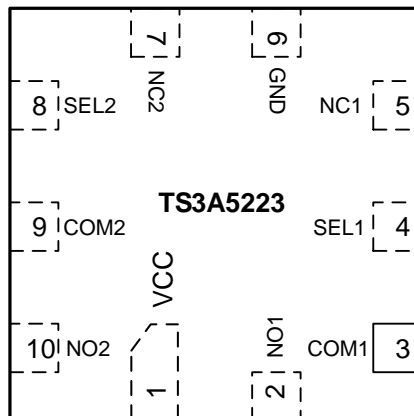

**Pin Functions**

NAME	PIN NUMBER	DESCRIPTION
VCC	1	Positive supply Input – Connect 1.65 V to 3.6 V supply voltage
NC1	5	Signal path Input/Output signal pins
NO1	2	
NC2	7	
NO2	10	
COM1, COM2	3, 9	Common signal path Input/Output signal pins
GND	6	Ground reference pin
SEL1, SEL2	4, 8	Select digital logic pin. Logic low connects COM to NC, Logic high connects COM to NO

## 6 Specifications

### 6.1 Absolute Maximum Ratings<sup>(1)</sup>

 Specified at  $T_A = -40^{\circ}\text{C}$  to  $85^{\circ}\text{C}$  unless otherwise noted.

		VALUE		UNIT
		MIN	MAX	
V <sub>CC</sub>	Positive DC supply voltage	-0.3	4.3 <sup>(2)</sup>	V
V <sub>COM</sub> V <sub>NO</sub> V <sub>NC</sub>	Analog voltage	-0.3	4.3 <sup>(2)</sup>	V
I <sub>COM</sub> I <sub>NO</sub> I <sub>NC</sub>	On-state switch continuous current		±300	mA
I <sub>COM</sub> I <sub>NO</sub> I <sub>NC</sub>	On-state switch peak current (1ms pulse at 10% duty cycle)		±500	mA
P <sub>D</sub>	Total device power dissipation at T <sub>A</sub> = 85°C	10-μQFN RSW	430	mW
T <sub>A</sub>	Operating free-air ambient temperature range	-40	85	°C
T <sub>J</sub>	Junction temperature range	-55	150	°C
T <sub>stg</sub>	Storage temperature range	-55	150	°C

- (1) Stresses beyond those listed under "Absolute Maximum Ratings" may cause permanent damage to the device. These are stress ratings only and functional operation of the device at these conditions is not implied. Exposure to absolute-maximum-rated conditions for extended periods may affect device reliability.
- (2) Not rated for continuous operation, 0.5% duty cycle at 1 kHz recommended

### 6.2 ESD Ratings

		VALUE	UNIT
V <sub>(ESD)</sub>	Electrostatic discharge	Human-body model (HBM), per ANSI/ESDA/JEDEC JS-001 <sup>(1)</sup>	±2000
		Charged-device model (CDM), per JEDEC specification JESD22-C101 <sup>(2)</sup>	±500

- (1) JEDEC document JEP155 states that 500-V HBM allows safe manufacturing with a standard ESD control process.
- (2) JEDEC document JEP157 states that 250-V CDM allows safe manufacturing with a standard ESD control process.

### 6.3 Recommended Operating Conditions

over operating free-air temperature range (unless otherwise noted)

		MIN	MAX	UNIT
V <sub>CC</sub>	Positive DC supply voltage	1.65	3.6	V
V <sub>COM</sub> , V <sub>NO</sub> , V <sub>NC</sub>	Analog voltage range	0	V <sub>CC</sub>	V
V <sub>SEL1</sub> V <sub>SEL2</sub>	Digital logic voltage	0	V <sub>CC</sub>	V
T <sub>A</sub>	Operating free-air ambient temperature range	-40	85	°C

### 6.4 Thermal Information

THERMAL METRIC <sup>(1)</sup>		TS3A5223	UNIT
		RSW (UQFN)	
		10 PINS	
R <sub>θJA</sub>	Junction-to-ambient thermal resistance	92.5	°C/W
R <sub>θJC(top)</sub>	Junction-to-case (top) thermal resistance	46.0	°C/W
R <sub>θJB</sub>	Junction-to-board thermal resistance	44.5	°C/W
ψ <sub>JT</sub>	Junction-to-top characterization parameter	1.5	°C/W
ψ <sub>JB</sub>	Junction-to-board characterization parameter	44.5	°C/W
R <sub>θJC(bot)</sub>	Junction-to-case (bottom) thermal resistance	31.2	°C/W

- (1) For more information about traditional and new thermal metrics, see the [Semiconductor and IC Package Thermal Metrics](#) application report.

## 6.5 Electrical Characteristics

Specified over the recommended junction temperature range  $T_A = T_J = -40^{\circ}\text{C}$  to  $85^{\circ}\text{C}$ . Typical values are at  $T_A = T_J = 25^{\circ}\text{C}$  (unless otherwise noted).

PARAMETER		$V_{CC}$ (V)	TEST CONDITIONS	MIN	TYP	MAX	UNIT
<b>DC CHARACTERISTICS</b>							
$V_{IH}$	High-level Input voltage SEL1, SEL2 inputs	3.6		0.8			V
		2.3		0.8			
		1.8		0.8			
$V_{IL}$	Low-level Input voltage SEL1, SEL2 inputs	3.6				0.3	V
		2.3				0.3	
		1.8				0.3	
$R_{ON}$	Switch ON Resistance	3.6	$V_S = 0$ to $V_{CC}$ , $I_S = 100$ mA, $V_{SEL} = 1$ V, $0$ V		0.45	0.6	$\Omega$
		2.3			0.6	0.8	
		1.8			0.85	1.2	
$\Delta R_{ON}$	Difference of on-state resistance between switches	3.6	$V_S = 2$ V, $0.8$ V, $I_S = 100$ mA, $V_{SEL} = 1$ V, $0$ V		0.05		$\Omega$
$R_{ON-FLAT}$	ON resistance flatness	3.6	$V_S = 0$ to $V_{CC}$ , $I_S = 100$ mA, $V_{SEL} = 1$ V, $0$ V		0.1	0.2	$\Omega$
		2.3			0.15	0.35	
		1.8			0.4	0.65	
$I_{OFF}$	NC, NO pin leakage current when switch is off	3.6	$V_S = 0.3$ or $3.0$ V, $V_{COM} = 3$ or $0.3$ V		5	90	nA
$I_{S(ON)}$	NC, NO pin leakage current when switch is on	3.6	$V_S = 0.3$ or $3.0$ V, $V_{COM} = \text{No Load}$		4	60	nA
$I_{SEL}$	Select pin input leakage current	$V_S$	$V_S = 0$ or $3.6$ V			100	nA
$I_{CC}$	Quiescent supply current	3.6	$V_{SEL} = 0$ or $V_{CC}$		700	2000	nA
$I_{CCLV}$	Supply current change	3.6	$V_{SEL} = 1$ V to $V_{SEL} = V_{CC}$			200	nA
<b>SWITCHING PARAMETERS<sup>(1)(2)</sup></b>							
$t_{PHL}$	Logic high to low propagation delay	3.6	$R_L = 50$ $\Omega$ , $C_L = 35$ pF		0.1		ns
		2.5			0.2		
		1.8			0.2		
$t_{PLH}$	Logic low to high propagation delay	3.6	$R_L = 50$ $\Omega$ , $C_L = 35$ pF		0.1		ns
		2.5			0.2		
		1.8			0.2		
$t_{ON}$	Turn-ON time	2.3 - 3.6	$R_L = 50$ $\Omega$ , $C_L = 35$ pF, $V_S = 1.5$ V			70	ns
$t_{OFF}$	Turn-OFF time	2.3 - 3.6	$R_L = 50$ $\Omega$ , $C_L = 35$ pF, $V_S = 1.5$ V			75	ns
$t_{BBM}$	Break-before-make time delay	3.6	$R_L = 50$ $\Omega$ , $C_L = 35$ pF, $V_S = 1.5$ V	2	8		ns
$Q_{INJ}$	Charge Injection	3.6	$C_L = 1$ nF, $V_S = 0$ V		40		pC
<b>AC CHARACTERISTICS</b>							
BW	-3 dB Bandwidth	1.65 - 3.6	$R_L = 50$ $\Omega$ , $C_L = 35$ pF		80		MHz
$V_{ISO}$	Channel OFF isolation	1.65 - 3.6	$V_S = 1$ Vrms, $f = 100$ kHz		-70		dB
$V_{Xtalk}$	Channel-to-Channel Crosstalk	1.65 - 3.6	$V_S = 1$ Vrms, $f = 100$ kHz		-75		dB
THD	Total harmonic distortion	1.65 - 3.6	$R_L = 600$ $\Omega$ , $V_{SEL} = 2$ Vpk-pk, $f = 20$ Hz to $20$ kHz		0.01%		
$C_{SEL}$	Select pin input capacitance	3.3	$f = 1$ MHz		3		pF
$C_{ON}$	NC, NO, and COM input capacitance when switch is on	3.3	$f = 1$ MHz		115		pF
$C_{OFF}$	NC, NO, and COM input capacitance when switch is off	3.3	$f = 1$ MHz		50		pF

- (1) Rise and Fall propagation delays,  $t_{PHL}$  and  $t_{PLH}$ , are measured between 50% values of the input and the corresponding output signal amplitude transition.
- (2) Specified by characterization only. Validated during qualification. Not measured in production testing.

## 6.6 Typical Characteristics

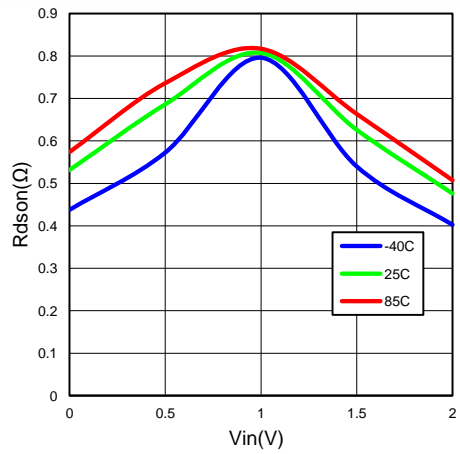

$V_{CC} = 1.8 \text{ V}$

Figure 1. On-Resistance vs Switch Input Voltage

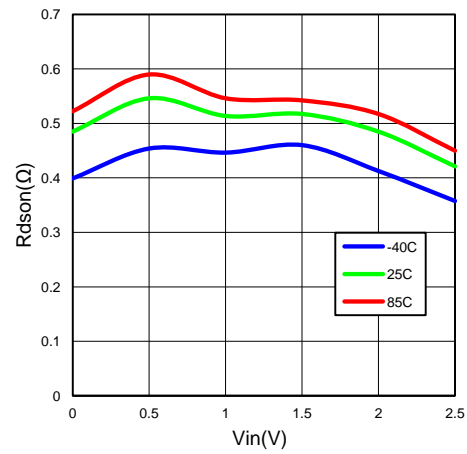

$V_{CC} = 2.3 \text{ V}$

Figure 2. On-Resistance vs Switch Input Voltage

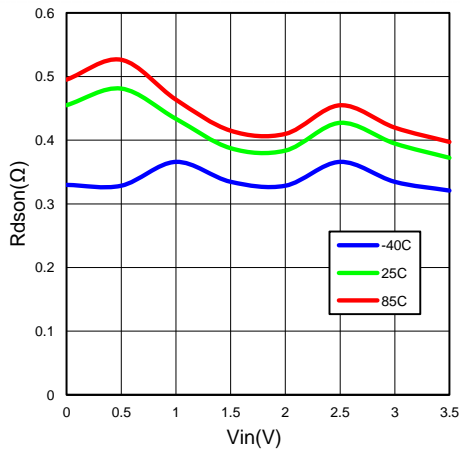

$V_{CC} = 3 \text{ V}$

Figure 3. On-Resistance vs Switch Input Voltage

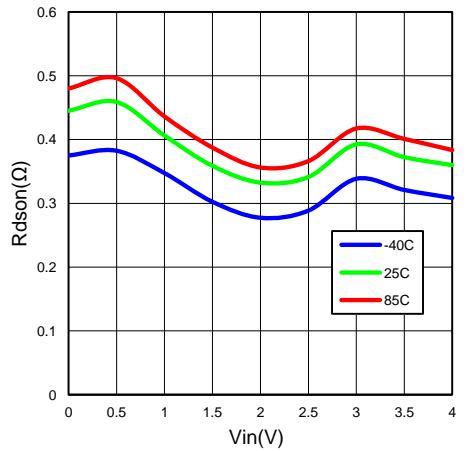

$V_{CC} = 3.6 \text{ V}$

Figure 4. On-Resistance vs. Switch Input Voltage

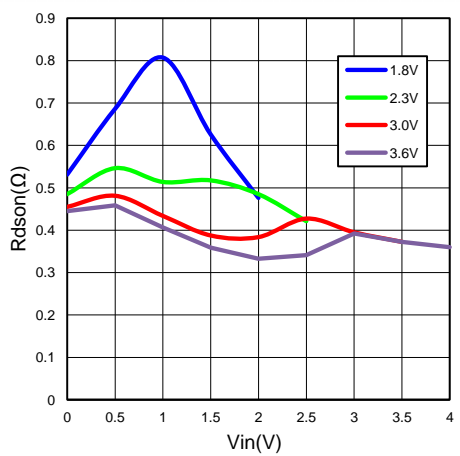

$T_A = 25^\circ\text{C}$

Figure 5. On-Resistance vs. Switch Input Voltage

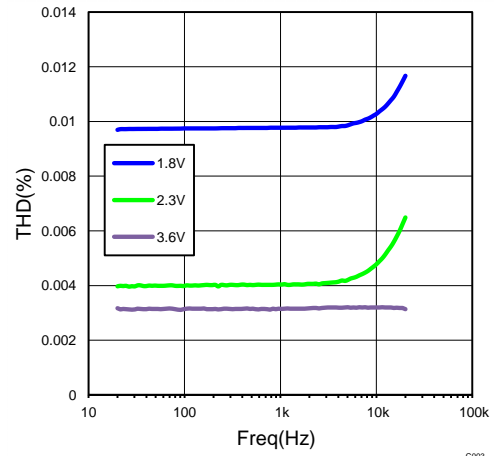

Figure 6. Total Harmonic Distortion

## 7 Parameter Measurement Information

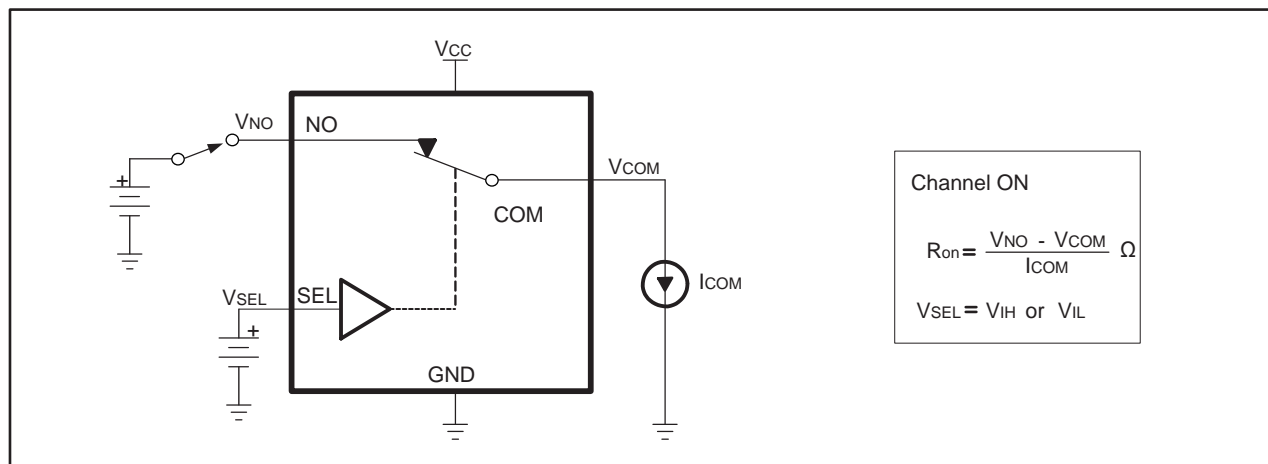

Figure 7. ON-State Resistance ( $R_{ON}$ )

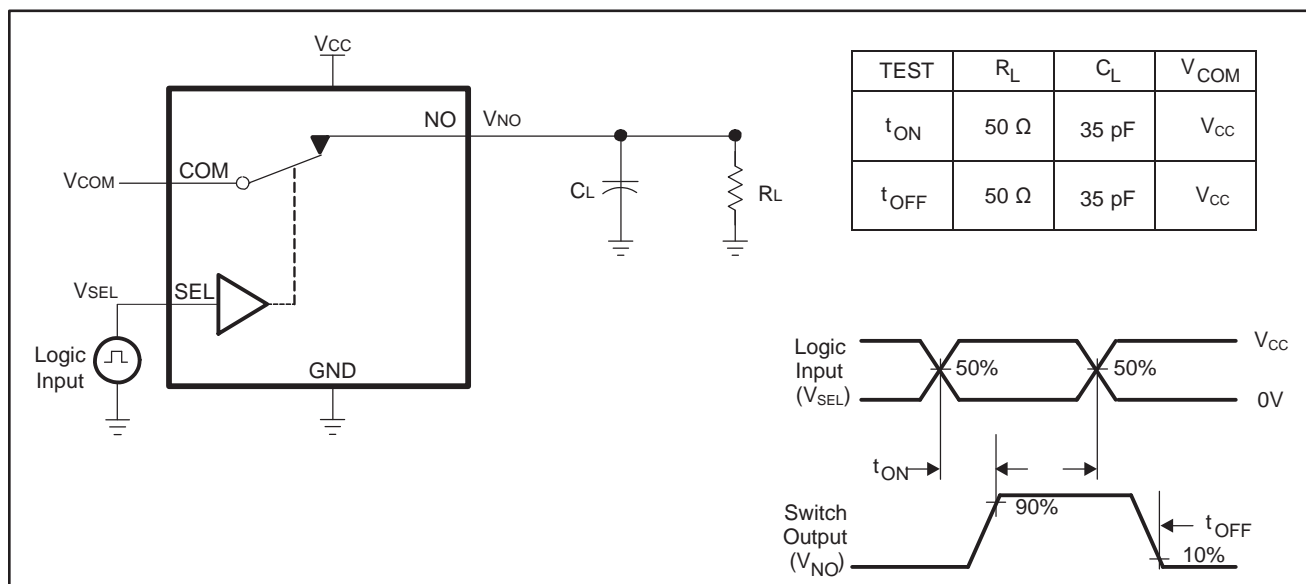

Figure 8. Turn-On ( $t_{ON}$ ) and Turn-Off Time ( $t_{OFF}$ )

Parameter Measurement Information (continued)

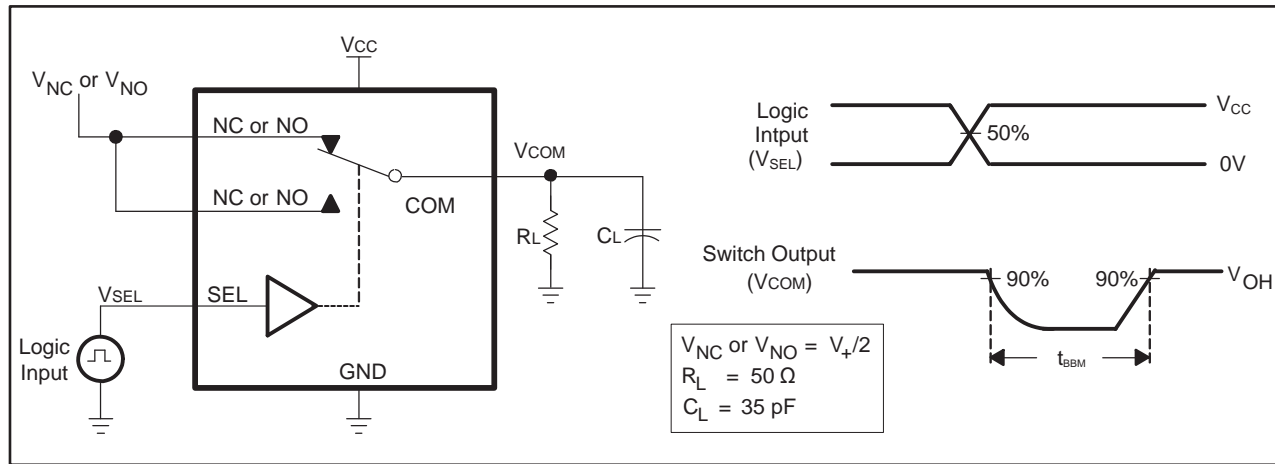

Figure 9. Break-Before-Make Time ( $t_{BBM}$ )

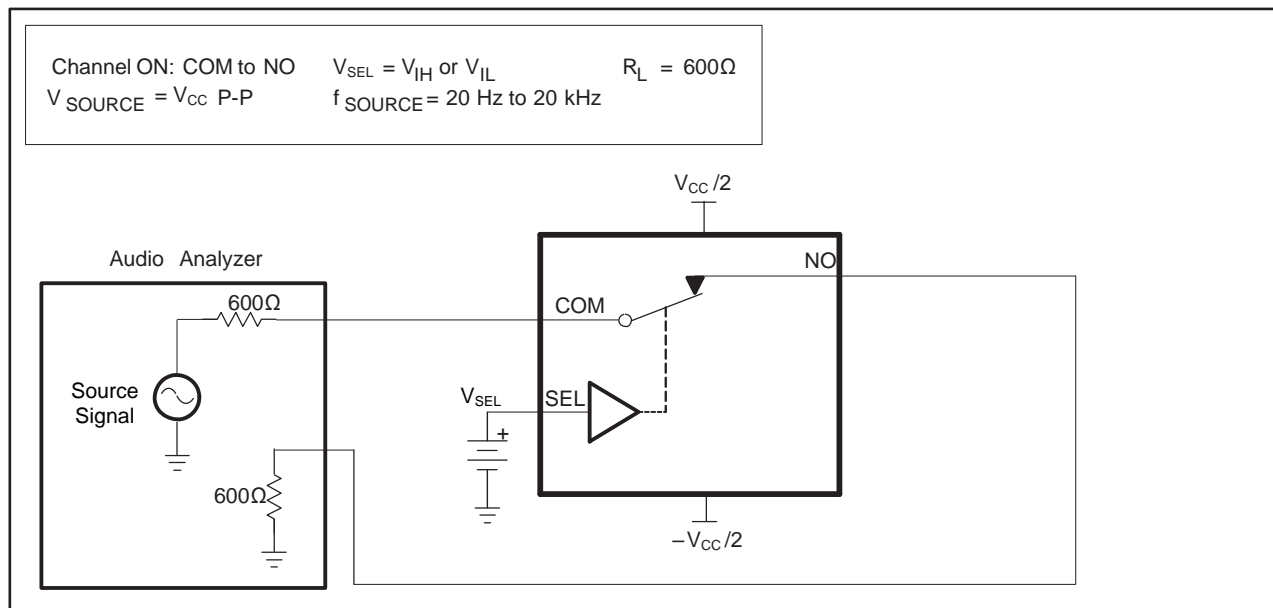

Figure 10. TOTAL HARMONIC DISTORTION (THD)

Parameter Measurement Information (continued)

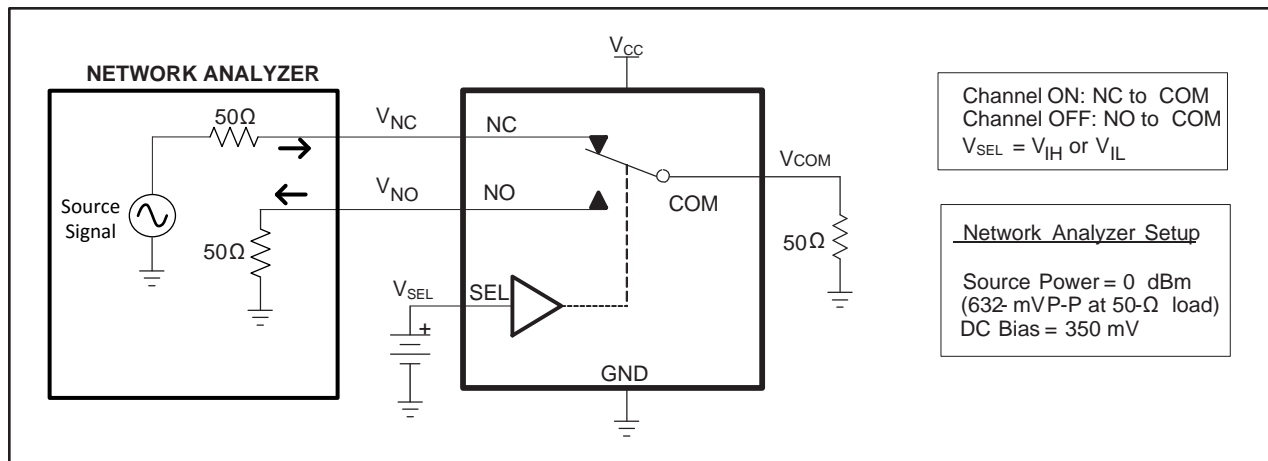

Figure 11. Crosstalk ( $X_{TALK}$ )

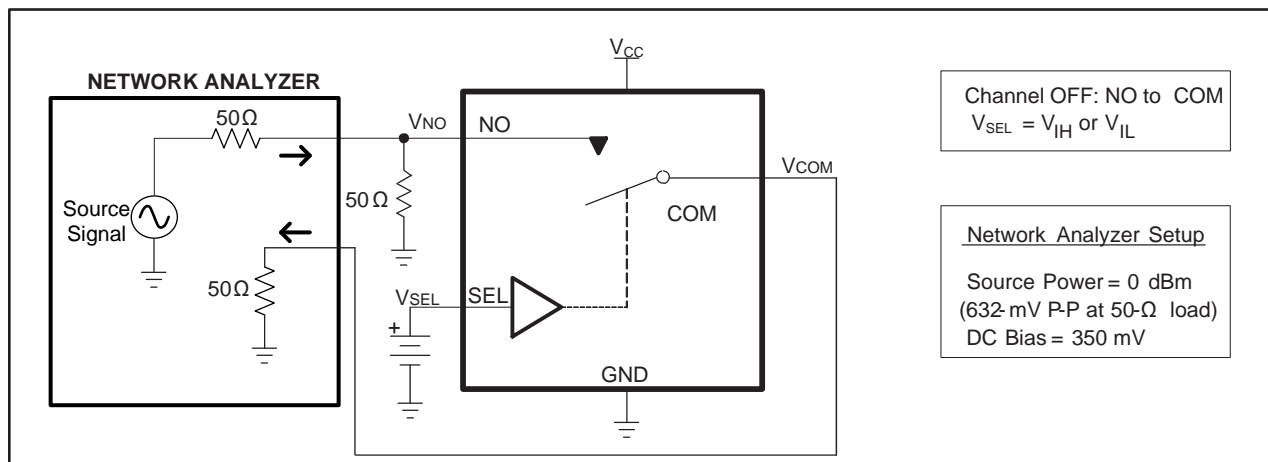

Figure 12. OFF Isolation ( $O_{ISO}$ )

## 8 Detailed Description

### 8.1 Overview

The TS3A5223 is a bidirectional, 2-channel, single-pole double-throw (2:1 SPDT) analog switch that is designed to operate from 1.65 V to 3.6 V. This switch solution comes in a small 1.4mm x 1.8 mm QFN package while maintaining excellent signal integrity, which makes the TS3A5223 suitable for a wide range of applications in personal electronics, portable instrumentation, and test and home electronics. The device maintains the signal integrity by its low ON-state resistance, excellent ON-state resistance matching, and total harmonic distortion (THD) performance. To prevent signal distortion during the transferring of a signal from one channel to another, the TS3A5223 device also has a specified break-before-make feature.

### 8.2 Functional Block Diagram

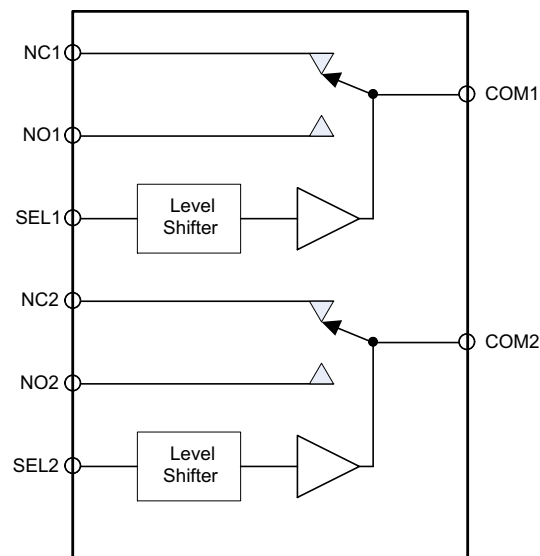

Copyright © 2017, Texas Instruments Incorporated

### 8.3 Feature Description

#### 8.3.1 Digital Logic Translation

The TS3A5223 devices supports down to 1-V logic signals irrespective of the supply voltage. The device accomplishes this with integrated level shifters on the digital input SEL1 and SEL2 pins.

#### 8.3.2 Break-Before-Make

The TS3A5223 devices prevents signal distortions when switching signals between the NO and NC pins by completely turning off one signal path before turning on the other signal path. The break-before-make timing specifications are found in the [Electrical Characteristics](#) table.

## 8.4 Device Functional Modes

Logic low voltage on SEL1 or SEL2 pins connect the COM pin to NC pin.

Logic high voltage on SEL1 or SEL2 pins connect the COM pin to NO pin.

**Table 1. TS3A5223 Function Table**

SEL1	SEL2	COM1	COM2
0	0	NC1	NC2
1	1	NO1	NO2
1	0	NO1	NC2
0	1	NC1	NO2

## 9 Application and Implementation

### NOTE

Information in the following applications sections is not part of the TI component specification, and TI does not warrant its accuracy or completeness. TI's customers are responsible for determining suitability of components for their purposes. Customers should validate and test their design implementation to confirm system functionality.

### 9.1 Application Information

The TS3A5223 switch is bidirectional, so the NO, NC and COM pins can be used as either inputs or outputs. This switch is typically used when there is only one signal path that needs to be able to communicate to 2 different signal paths.

### 9.2 Typical Application

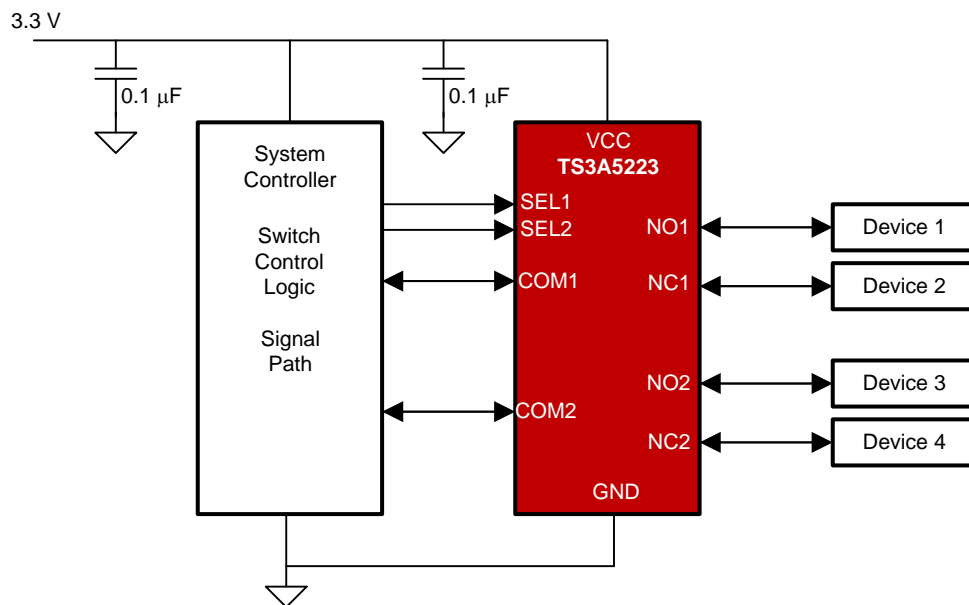

Copyright © 2017, Texas Instruments Incorporated

**Figure 13. Typical Application**

#### 9.2.1 Design Requirements

The TS3A5223 can be properly operated without any external components.

Unused, pins COM, NC, and NO may be left floating or grounded.

Digital control pins IN must be pulled up to VCC or down to GND to avoid undesired switch positions that could result from the floating pin and cause excess current consumption. For more information, refer to the application note [Implications of Slow or Floating CMOS Inputs \(SCBA002\)](#).

#### 9.2.2 Detailed Design Procedure

Ensure that all of the signals passing through the switch are within the ranges specified in [Recommended Operating Conditions](#) to ensure proper performance.

## Typical Application (continued)

### 9.2.3 Application Curves

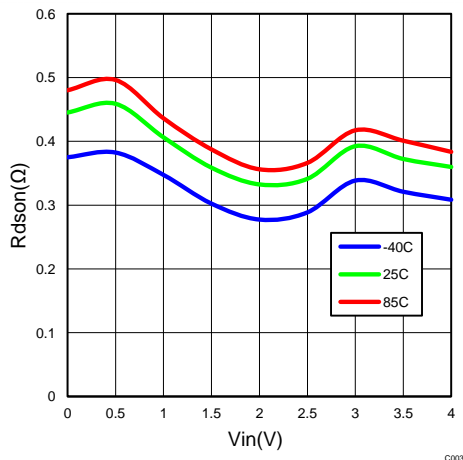

$$V_{CC} = 3.6 \text{ V}$$

Figure 14. On-Resistance vs. Switch Input Voltage

## 10 Power Supply Recommendations

TI recommends proper power-supply sequencing for all CMOS devices. Do not exceed the absolute-maximum ratings, because stresses beyond the listed ratings can cause permanent damage to the device. Always sequence VCC on first, followed by NO, NC, or COM. Although it is not required, power-supply bypassing improves noise margin and prevents switching noise propagation from the VCC supply to other components. A 0.1- $\mu$ F capacitor, connected from VCC to GND, is adequate for most applications.

## 11 Layout

### 11.1 Layout Guidelines

- TI recommends following common printed-circuit board layout guidelines to ensure reliability of the device.
- Bypass capacitors should be used on power supplies.
- Short trace lengths should be used to avoid excessive loading.

### 11.2 Layout Example

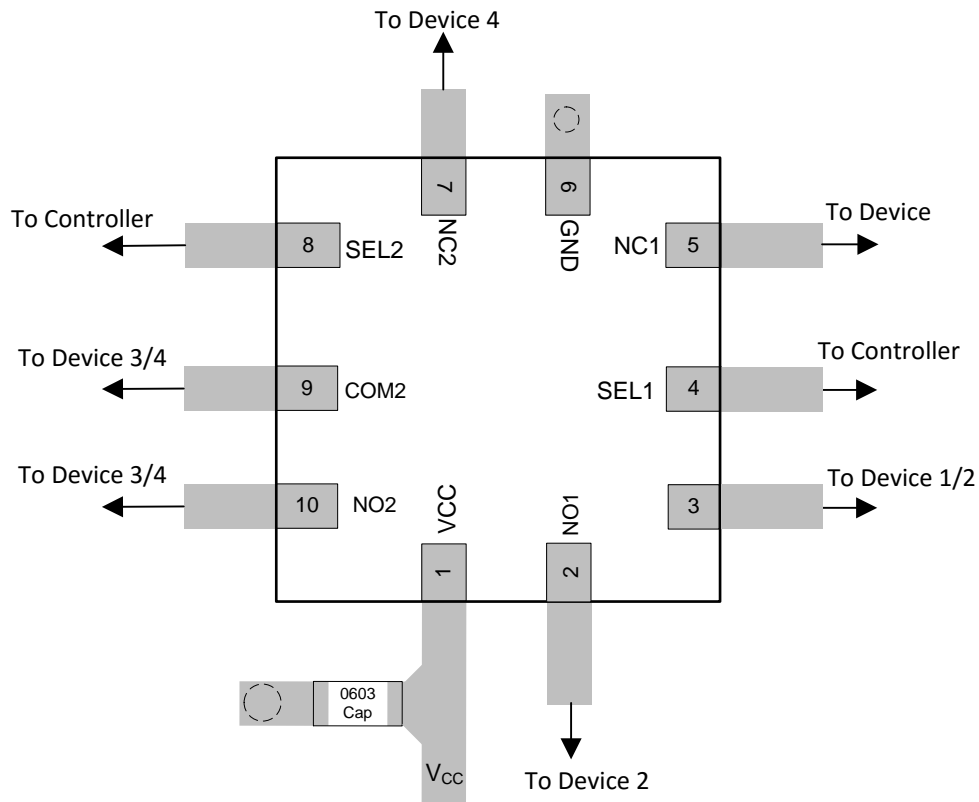

**Figure 15. Layout Example**

## 12 Device and Documentation Support

### 12.1 Documentation Support

### 12.2 Receiving Notification of Documentation Updates

To receive notification of documentation updates, navigate to the device product folder on ti.com. In the upper right corner, click on *Alert me* to register and receive a weekly digest of any product information that has changed. For change details, review the revision history included in any revised document.

### 12.3 Community Resources

The following links connect to TI community resources. Linked contents are provided "AS IS" by the respective contributors. They do not constitute TI specifications and do not necessarily reflect TI's views; see TI's [Terms of Use](#).

**TI E2E™ Online Community** *TI's Engineer-to-Engineer (E2E) Community*. Created to foster collaboration among engineers. At e2e.ti.com, you can ask questions, share knowledge, explore ideas and help solve problems with fellow engineers.

**Design Support** *TI's Design Support* Quickly find helpful E2E forums along with design support tools and contact information for technical support.

### 12.4 Trademarks

E2E is a trademark of Texas Instruments.

### 12.5 Electrostatic Discharge Caution



This integrated circuit can be damaged by ESD. Texas Instruments recommends that all integrated circuits be handled with appropriate precautions. Failure to observe proper handling and installation procedures can cause damage.

ESD damage can range from subtle performance degradation to complete device failure. Precision integrated circuits may be more susceptible to damage because very small parametric changes could cause the device not to meet its published specifications.

### 12.6 Glossary

[SLYZ022](#) — *TI Glossary*.

This glossary lists and explains terms, acronyms, and definitions.

## 13 Mechanical, Packaging, and Orderable Information

The following pages include mechanical, packaging, and orderable information. This information is the most current data available for the designated devices. This data is subject to change without notice and revision of this document. For browser-based versions of this data sheet, refer to the left-hand navigation.

**PACKAGING INFORMATION**

Orderable Device	Status (1)	Package Type	Package Drawing	Pins	Package Qty	Eco Plan (2)	Lead finish/ Ball material (6)	MSL Peak Temp (3)	Op Temp (°C)	Device Marking (4/5)	Samples
TS3A5223RSWR	ACTIVE	UQFN	RSW	10	3000	RoHS & Green	NIPDAU	Level-1-260C-UNLIM	-40 to 85	B2A	Samples

(1) The marketing status values are defined as follows:

**ACTIVE:** Product device recommended for new designs.

**LIFEBUY:** TI has announced that the device will be discontinued, and a lifetime-buy period is in effect.

**NRND:** Not recommended for new designs. Device is in production to support existing customers, but TI does not recommend using this part in a new design.

**PREVIEW:** Device has been announced but is not in production. Samples may or may not be available.

**OBSOLETE:** TI has discontinued the production of the device.

(2) **RoHS:** TI defines "RoHS" to mean semiconductor products that are compliant with the current EU RoHS requirements for all 10 RoHS substances, including the requirement that RoHS substance do not exceed 0.1% by weight in homogeneous materials. Where designed to be soldered at high temperatures, "RoHS" products are suitable for use in specified lead-free processes. TI may reference these types of products as "Pb-Free".

**RoHS Exempt:** TI defines "RoHS Exempt" to mean products that contain lead but are compliant with EU RoHS pursuant to a specific EU RoHS exemption.

**Green:** TI defines "Green" to mean the content of Chlorine (Cl) and Bromine (Br) based flame retardants meet JS709B low halogen requirements of <=1000ppm threshold. Antimony trioxide based flame retardants must also meet the <=1000ppm threshold requirement.

(3) MSL, Peak Temp. - The Moisture Sensitivity Level rating according to the JEDEC industry standard classifications, and peak solder temperature.

(4) There may be additional marking, which relates to the logo, the lot trace code information, or the environmental category on the device.

(5) Multiple Device Markings will be inside parentheses. Only one Device Marking contained in parentheses and separated by a "-" will appear on a device. If a line is indented then it is a continuation of the previous line and the two combined represent the entire Device Marking for that device.

(6) Lead finish/Ball material - Orderable Devices may have multiple material finish options. Finish options are separated by a vertical ruled line. Lead finish/Ball material values may wrap to two lines if the finish value exceeds the maximum column width.

**Important Information and Disclaimer:**The information provided on this page represents TI's knowledge and belief as of the date that it is provided. TI bases its knowledge and belief on information provided by third parties, and makes no representation or warranty as to the accuracy of such information. Efforts are underway to better integrate information from third parties. TI has taken and continues to take reasonable steps to provide representative and accurate information but may not have conducted destructive testing or chemical analysis on incoming materials and chemicals. TI and TI suppliers consider certain information to be proprietary, and thus CAS numbers and other limited information may not be available for release.

In no event shall TI's liability arising out of such information exceed the total purchase price of the TI part(s) at issue in this document sold by TI to Customer on an annual basis.

## TAPE AND REEL INFORMATION



### QUADRANT ASSIGNMENTS FOR PIN 1 ORIENTATION IN TAPE



\*All dimensions are nominal

Device	Package Type	Package Drawing	Pins	SPQ	Reel Diameter (mm)	Reel Width W1 (mm)	A0 (mm)	B0 (mm)	K0 (mm)	P1 (mm)	W (mm)	Pin1 Quadrant
TS3A5223RSWR	UQFN	RSW	10	3000	180.0	9.5	1.6	2.0	4.0	4.0	8.0	Q1

TAPE AND REEL BOX DIMENSIONS



\*All dimensions are nominal

Device	Package Type	Package Drawing	Pins	SPQ	Length (mm)	Width (mm)	Height (mm)
TS3A5223RSWR	UQFN	RSW	10	3000	184.0	184.0	19.0



# EXAMPLE BOARD LAYOUT

RSW0010A

UQFN - 0.55 mm max height

PLASTIC QUAD FLATPACK - NO LEAD

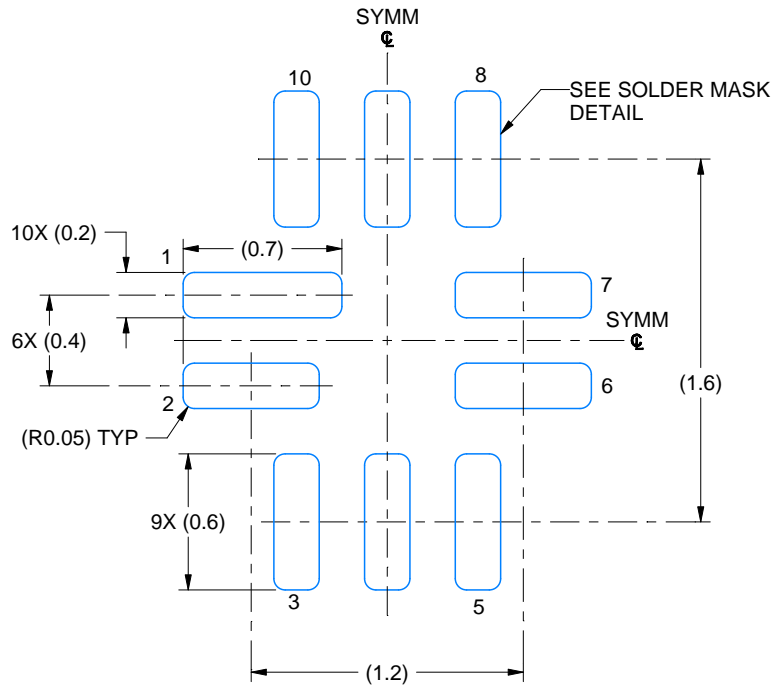

LAND PATTERN EXAMPLE  
EXPOSED METAL SHOWN  
SCALE: 30X

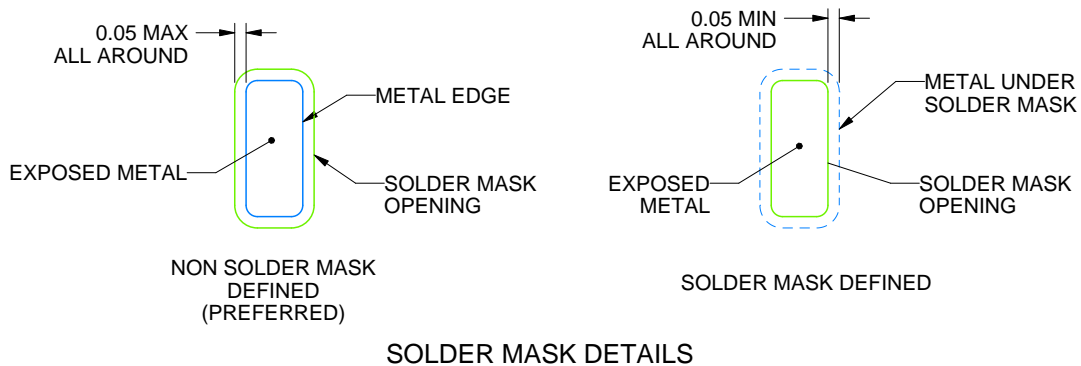

SOLDER MASK DETAILS

4224897/A 03/2019

NOTES: (continued)

- This package is designed to be soldered to a thermal pad on the board. For more information, see Texas Instruments literature number SLUA271 ([www.ti.com/lit/sluea271](http://www.ti.com/lit/sluea271)).
- Vias are optional depending on application, refer to device data sheet. If any vias are implemented, refer to their locations shown on this view. It is recommended that vias under paste be filled, plugged or tented.

# EXAMPLE STENCIL DESIGN

RSW0010A

UQFN - 0.55 mm max height

PLASTIC QUAD FLATPACK - NO LEAD

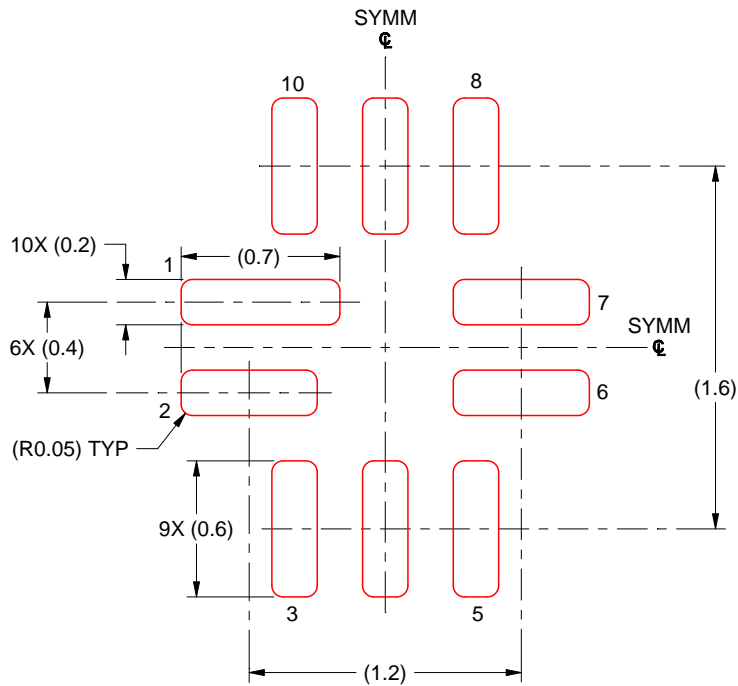

SOLDER PASTE EXAMPLE  
BASED ON 0.125 MM THICK STENCIL  
SCALE: 30X

4224897/A 03/2019

NOTES: (continued)

6. Laser cutting apertures with trapezoidal walls and rounded corners may offer better paste release. IPC-7525 may have alternate design recommendations.

## IMPORTANT NOTICE AND DISCLAIMER

TI PROVIDES TECHNICAL AND RELIABILITY DATA (INCLUDING DATASHEETS), DESIGN RESOURCES (INCLUDING REFERENCE DESIGNS), APPLICATION OR OTHER DESIGN ADVICE, WEB TOOLS, SAFETY INFORMATION, AND OTHER RESOURCES "AS IS" AND WITH ALL FAULTS, AND DISCLAIMS ALL WARRANTIES, EXPRESS AND IMPLIED, INCLUDING WITHOUT LIMITATION ANY IMPLIED WARRANTIES OF MERCHANTABILITY, FITNESS FOR A PARTICULAR PURPOSE OR NON-INFRINGEMENT OF THIRD PARTY INTELLECTUAL PROPERTY RIGHTS.

These resources are intended for skilled developers designing with TI products. You are solely responsible for (1) selecting the appropriate TI products for your application, (2) designing, validating and testing your application, and (3) ensuring your application meets applicable standards, and any other safety, security, or other requirements. These resources are subject to change without notice. TI grants you permission to use these resources only for development of an application that uses the TI products described in the resource. Other reproduction and display of these resources is prohibited. No license is granted to any other TI intellectual property right or to any third party intellectual property right. TI disclaims responsibility for, and you will fully indemnify TI and its representatives against, any claims, damages, costs, losses, and liabilities arising out of your use of these resources.

TI's products are provided subject to TI's Terms of Sale ([www.ti.com/legal/termsofsale.html](http://www.ti.com/legal/termsofsale.html)) or other applicable terms available either on [ti.com](http://ti.com) or provided in conjunction with such TI products. TI's provision of these resources does not expand or otherwise alter TI's applicable warranties or warranty disclaimers for TI products.

Mailing Address: Texas Instruments, Post Office Box 655303, Dallas, Texas 75265  
Copyright © 2020, Texas Instruments Incorporated

## Looking for pricing, stock, or lifecycle information?

Click below to explore more details on WIN SOURCE:

 [View TS3A5223RSWR on WIN SOURCE](#)

 [Texas Instruments](#) Information

## Optimize Your Supply Chain with WIN SOURCE Solutions

-  Global Sourcing Solution
-  Obsolete Management
-  Cost Control Management
-  Shortage Management
-  Alternative Solution
-  Excess Inventory Management