



# THE DATASHEET OF TS3A225ERTER



## AUTONOMOUS AUDIO HEADSET SWITCH

Check for Samples: [TS3A225E](#)

### FEATURES

- $V_{DD}$  Range = 2.7 V to 4.5 V
- Break Before Make Stereo Jack Switches
- $R_{on}$  for Ground FET Switches
  - WCSP Package: 70 m $\Omega$
  - QFN Package: 100 m $\Omega$
- Autonomous Detection of GND and MIC Connections
- Detection Triggered by I<sup>2</sup>C or External Trigger Pin
- HDA Compatible MIC Present Indicator
- 1.8V Compatible I<sup>2</sup>C Switch Control
- ESD Performance Tested Per JESD 22:
  - 2000-V Human-Body Model (A114-B, Class II)
  - 500-V Charged-Device Model (C101)
- ESD Performance (SLEEVE, RING2, TIP)
  - $\pm 8$ -kV Contact Discharge (IEC 61000-4-2)

### APPLICATIONS

- Mobile Phones/ Tablet PCs
- Notebook Computers

### DESCRIPTION

The TS3A225E is an audio headset switch device. The device detects the presence of an analog microphone and switches a system analog microphone pin between different connectors in an audio stereo jack. The microphone connection in a stereo connector can be swapped with the ground connection depending on manufacturer. When the TS3A225E detects a certain configuration, the device automatically connects the microphone line to the appropriate pin. The device also reports the presence of an analog microphone on an audio stereo jack.

In some systems, it is desirable to connect the stereo jack pin to ground. The TS3A225E provides two internal low resistance (<100m $\Omega$ ) FET switches for ground shorting.

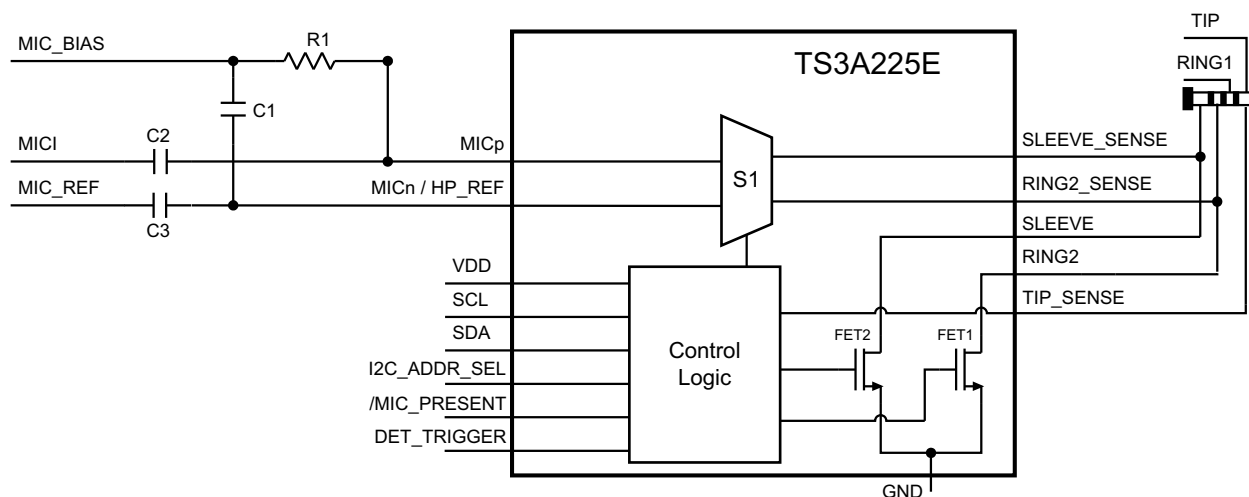

### ORDERING INFORMATION

T <sub>A</sub>	PACKAGE <sup>(1)(2)</sup>		ORDERABLE PART NUMBER	TOP-SIDE MARKING
	-40°C to 85°C	RTE - QFN		
YFF - WCSP		Tape and reel	TS3A225EYFFR	YP225E

(1) Package drawings, thermal data, and symbolization are available at [www.ti.com/packaging](http://www.ti.com/packaging).

(2) For the most current package and ordering information, see the Package Option Addendum at the end of this document, or see the TI Web site at [www.ti.com](http://www.ti.com).



Please be aware that an important notice concerning availability, standard warranty, and use in critical applications of Texas Instruments semiconductor products and disclaimers thereto appears at the end of this data sheet.



These devices have limited built-in ESD protection. The leads should be shorted together or the device placed in conductive foam during storage or handling to prevent electrostatic damage to the MOS gates.

**PACKAGE OPTION #1: YFF- WCSP**

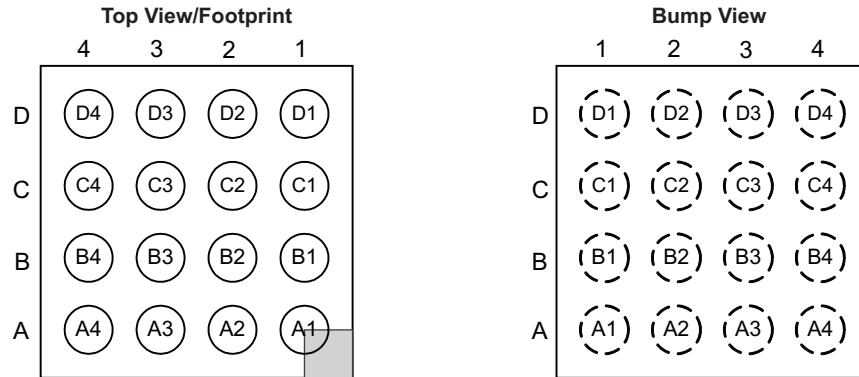

Die Size: 1.56mm x 1.56mm (± 0.03mm)  
 Bump Size: 0.25mm  
 Bump Pitch: 0.4mm

**Table 1. TS3A225E Pin Mapping (Top View)**

	4	3	2	1
D	/MIC_PRESENT	TIP_SENSE	MICp	MICn
C	RING2	GND <sup>(1)</sup>	VDD <sup>(1)</sup>	RING2_SENSE
B	SLEEVE	GND <sup>(1)</sup>	VDD <sup>(1)</sup>	SLEEVE_SENSE
A	DET_TRIGGER	ADDR_SEL	SDA	SCL

(1) To ensure proper operation at least 1 of the VDD balls and at least 1 of the GND balls must be pad-connected.

**PIN DESCRIPTION – WCSP**

PIN #	PIN		DESCRIPTION
	WCSP	NAME	
A1	SCL	I/O	Clock from I <sup>2</sup> C bus. This can be connected to VDD if I <sup>2</sup> C is not used.
A2	SDA	I/O	Bidirectional data from/to I <sup>2</sup> C bus. This can be connected to VDD if I <sup>2</sup> C is not used.
A3	ADDR_SEL	I/O	This pin is used to change the device I2C address in an I <sup>2</sup> C system to avoid address conflict. Please see the External Pin Connection section for more details. This pin can be grounded if not needed.
A4	DET_TRIGGER	I/O	A rising edge from low to high on this pin triggers the detection. This pin can be connected to the headset jack to allow automatic pull-up to supply after headset insertion to initialize detection sequence. The detection trigger can be disabled or activated in I <sup>2</sup> C
B1	SLEEVE_SENSE	I/O	Connected to the SLEEVE segment of the jack. If SLEEVE segment on plug is MIC signal, this is connected to MICp. If not, this is connected to MICn and becomes the remote sensing feedback for the headphone.
B2	VDD	Supply	Power supply
B3	GND	Ground	Headphone ground connection (Current return path to headphone amplifier), switch ground reference.
B4	SLEEVE	I/O	Headphone current return path if SLEEVE is GND for headset. Connect to SLEEVE with low DCR trace.
C1	RING2_SENSE	I/O	Connected to the RING2 segment of the jack. If RING2 segment on plug is MIC signal, this is connected to MICp. If not, this is connected to MICn and becomes the remote sensing feedback for the headphone.
C2	VDD	Supply	Power supply
C3	GND	Ground	Headphone ground connection (Current return path to headphone amplifier), switch ground reference.
C4	RING2	I/O	Headphone current return path if RING2 is GND for headset. Connect to RING2 with low DCR trace.
D1	MICn	I/O	Microphone signal reference connection to codec.
D2	MICp	I/O	Microphone signal connection to codec. Microphone bias should be fed into this pin.
D3	TIP_SENSE	I/O	Connected to the TIP segment of the headphone jack
D4	/MIC_PRESENT	Output	Open Drain output. When pulled-low, it indicate that a mic is detected on the headset (switch for HDA sense resistor or INT output in an I2S based system. Default behavior is a hardware pulldown for HDA resistor. Programmable through I2C into an interrupt.)

**PACKAGE OPTION #2: RTE- QFN**

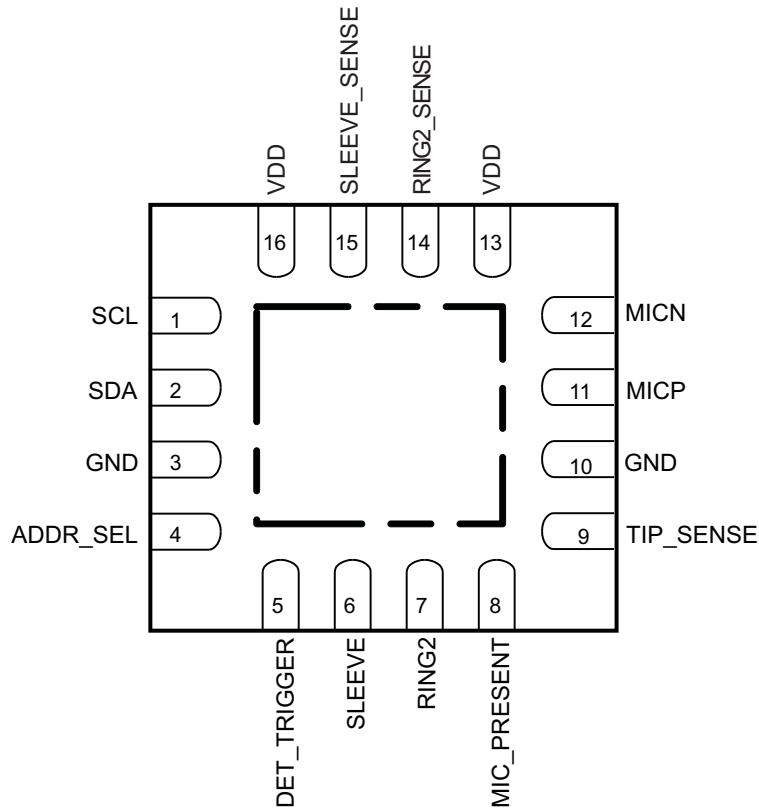

**Top View**  
 Package Size: 3 mm x 3 mm  
 Pitch: 0.5 mm

**PIN DESCRIPTION – QFN**

PIN #	PIN		
QFN	NAME	TYPE	DESCRIPTION
1	SCL	I/O	Clock from I <sup>2</sup> C bus. This can be connected to VDD if I <sup>2</sup> C is not used.
2	SDA	I/O	Bidirectional data from/to I <sup>2</sup> C bus. This can be connected to VDD if I <sup>2</sup> C is not used.
3	GND	Ground	Headphone ground connection (Current return path to headphone amplifier), switch ground reference.
4	ADDR_SEL	I/O	This pin is used to change the device I2C address in an I <sup>2</sup> C system to avoid address conflict. Please see the External Pin Connection section for more details. This pin can be grounded if not needed.
5	DET_TRIGGER	I/O	A rising edge from low to high on this pin triggers the detection. This pin can be connected to the headset jack to allow automatic pull-up to supply after headset insertion to initialize detection sequence. The detection trigger can be disabled or activated in I <sup>2</sup> C
6	SLEEVE	I/O	Headphone current return path if SLEEVE is GND for headset. Connect to SLEEVE with low DCR trace.
7	RING2	I/O	Headphone current return path if RING2 is GND for headset. Connect to RING2 with low DCR trace.
8	/MIC_PRESENT	Output	Open Drain output. When pulled-low, it indicate that a mic is detected on the headset (switch for HDA sense resistor or INT output in an I2S based system. Default behavior is a hardware pulldown for HDA resistor. Programmable through I2C into an interrupt.)
9	TIP_SENSE	I/O	Connected to the TIP segment of the headphone jack
10	GND	Ground	Headphone ground connection (Current return path to headphone amplifier), switch ground reference.
11	MICp	I/O	Microphone signal connection to codec. Microphone bias should be fed into this pin.
12	MICn	I/O	Microphone signal reference connection to codec.
13	VDD	Supply	Power supply
14	RING2_SENSE	I/O	Connected to the RING2 segment of the jack. If RING2 segment on plug is MIC signal, this is connected to MICp. If not, this is connected to MICn and becomes the remote sensing feedback for the headphone.
15	SLEEVE_SENSE	I/O	Connected to the SLEEVE segment of the jack. If SLEEVE segment on plug is MIC signal, this is connected to MICp. If not, this is connected to MICn and becomes the remote sensing feedback for the headphone.
16	VDD	Supply	Power supply

**FUNCTIONAL BLOCK DIAGRAM**

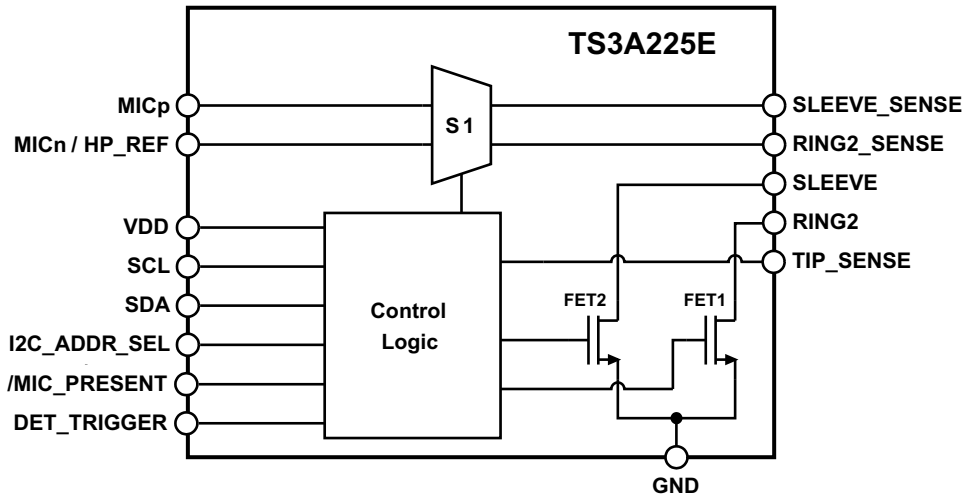

**Figure 1. Functional Block Diagram**

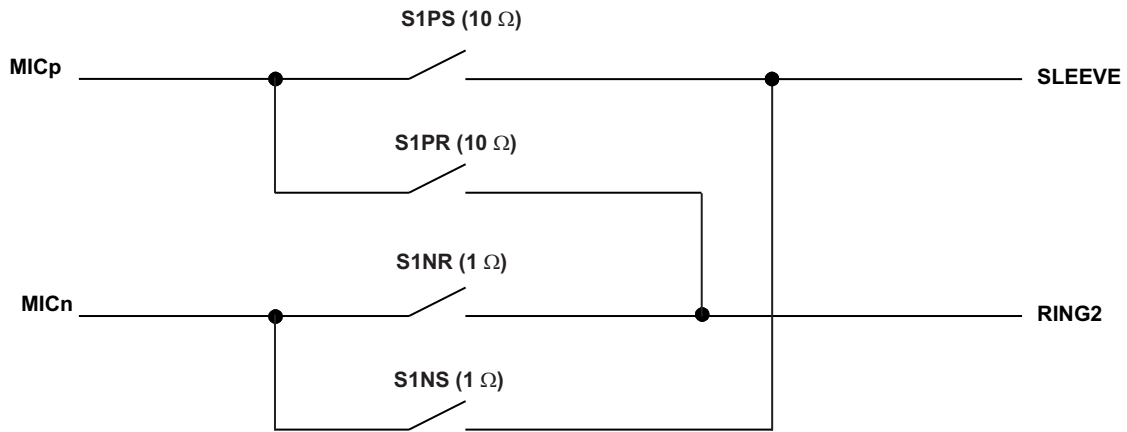

**Figure 2. S1 Mux Details**

## ABSOLUTE MAXIMUM RATINGS<sup>(1)(2)</sup>

over operating free-air temperature range (unless otherwise noted)

		VALUE	UNIT
V <sub>I</sub>	Voltage range on V <sub>DD</sub> <sup>(3)</sup>	-0.3 to 5	V
	Voltage range on SCL, SDA, ADDR_SEL, DET_TRIGGER, MICP, MICN, SLEEVE_SENSE, RING2_SENSE, RING2, SLEEVE <sup>(3)</sup>	-0.3 to V <sub>DD</sub> +0.5	V
T <sub>A</sub>	Operating ambient temperature range	-40 to 85	°C
T <sub>J (MAX)</sub>	Maximum operating junction temperature	125	°C
T <sub>stg</sub>	Storage temperature range	-65 to 150	°C
ESD rating	Machine model (JESD 22 A115)	100	V
	Charge device model (JESD 22 C101)	500	V
	Human body model (JESD 22 A114)	2	kV
	Contact discharge on SLEEVE_SENSE, RING2_SENSE, RING2, SLEEVE, TIP_SENSE (IEC 61000-4-2)	8	kV

- (1) Stresses beyond those listed under absolute maximum ratings may cause permanent damage to the device. These are stress ratings only, and functional operation of the device at these or any other conditions beyond those indicated under recommended operating conditions is not implied. Exposure to absolute–maximum–rated conditions for extended periods may affect device reliability.
- (2) In applications where high power dissipation and/or poor package thermal resistance is present, the maximum ambient temperature may have to be derated. Maximum ambient temperature [T<sub>A(max)</sub>] is dependent on the maximum operating junction temperature [T<sub>J(max)</sub>], the maximum power dissipation of the device in the application [P<sub>D(max)</sub>], and the junction-to-ambient thermal resistance of the part/package in the application (Q<sub>JA</sub>), as given by the following equation: T<sub>A(max)</sub> = T<sub>J(max)</sub> – (θ<sub>JA</sub> × P<sub>D(max)</sub>)
- (3) All voltage values are with respect to network ground terminal.

## RECOMMENDED OPERATING CONDITIONS

		MIN	MAX	UNIT	
V <sub>DD</sub>	Supply voltage range	2.7	4.5	V	
V <sub>IN</sub>	Digital input voltage range (SDA, SCL, ADDR_SEL, DET_TRIGGER)	0	V <sub>DD</sub>	V	
V <sub>IO</sub>	Input/Output voltage range (SLEEVE, SLEEVE_SENSE, RING2, RING2_SENSE, MICP, MICN)	0	V <sub>DD</sub>	V	
V <sub>IO(TIP)</sub>	Input/Output voltage range for TIP	-2	V <sub>DD</sub>	V	
V <sub>IH</sub>	Input logic high	SDA, SCL, ADDR_SEL	1.2	4.5	V
		DET_TRIGGER	V <sub>DD</sub> × 0.65	V <sub>DD</sub>	V
V <sub>IL</sub>	Input logic low	SDA, SCL, ADDR_SEL	0	0.4	V
		DET_TRIGGER	0	V <sub>DD</sub> × 0.40	V
T <sub>A</sub>	Operating temperature range	-40	85	°C	

## ELECTRICAL CHARACTERISTICS

Unless otherwise noted the specification applies over the  $V_{DD}$  range and operating junction temp  $-40^{\circ}\text{C} \leq T_A \leq 70^{\circ}\text{C}$ . Typical values are for  $V_{DD} = 3.3\text{V}$  and  $T_J = 25^{\circ}\text{C}$ .

PARAMETER		TEST CONDITIONS	MIN	TYP	MAX	UNIT
$V_{DD}$	Input voltage range		2.7	3.3	4.5	V
$I_{DD}$	Quiescent current	$V_{MIC} = 1.8\text{ V to }V_{DD}$		8	10	$\mu\text{A}$
$V_{OL}$	SDA output high voltage	$I_{OL} = 3\text{ mA}$			0.3	V
$I_{IN-I2C}$	SCL, SDA input leakage	$V_{MIC} = 1.8\text{ V to }V_{DD}$		0.1	1	$\mu\text{A}$
$I_{IN-ADDR}$	ADDR input leakage	$V_{MIC} = 0\text{ V}$		0.1	1	$\mu\text{A}$
<b>SWITCH RESISTANCE</b>						
$R_{F1}$ (WCSP)	FET1 on resistance (WCSP Package)	$V_{DD} = 2.7\text{ V}, V_{GND} = 0\text{ V}, I_{GND} = 10\text{ mA}$ (see <a href="#">Figure 3</a> )		70		$\text{m}\Omega$
$R_{F1}$ (QFN)	FET1 on resistance (QFN Package)			100		$\text{m}\Omega$
$R_{F2}$ (WCSP)	FET2 on resistance (WCSP Package)			70		$\text{m}\Omega$
$R_{F2}$ (QFN)	FET2 on resistance (QFN Package)			100		$\text{m}\Omega$
$R_{S1PS}$	S1PS on resistance	$V_{DD} = 2.7\text{ V},$ $V_{SLEEVE\_SENSE/RING2\_SENSE} = 0\text{ V to }2.7\text{ V},$ $I_{MIC} = \pm 10\text{ mA}$ (see <a href="#">Figure 4</a> )			10	$\Omega$
$R_{S1PR}$	S1PR on resistance				10	$\Omega$
$R_{S1NS}$	S1NS on resistance				1	$\Omega$
$R_{S1NR}$	S1NR on resistance				1	$\Omega$
$R_{MIC\_PRESENT}$	/MIC_PRESENT pin output resistance	$V_{DD} = 2.7\text{ V}$			25	$\Omega$
<b>SWITCH LEAKAGE CURRENT</b>						
$I_{OFF-0.1}$	FET1 and FET2 off leakage	$V_{IN} = 0\text{ V to }2.7\text{ V}, V_{OUT} = 0\text{ V},$ $V_{DD} = 4.5\text{V}$ (see <a href="#">Figure 5</a> )			1	$\mu\text{A}$
$I_{OFF-1}$	S1NS, S1NR off leakage				1	$\mu\text{A}$
$I_{OFF-10}$	S1PS, S1PR off leakage				1	$\mu\text{A}$
$I_{ON-1}$	S1NS, S1NR on leakage	$V_{IN} = 0\text{ V to }2.7\text{ V}, V_{OUT} = 0\text{ V},$ $V_{DD} = 4.5\text{ V}$ (see <a href="#">Figure 6</a> )			1	$\mu\text{A}$
$I_{ON-10}$	S1PS, S1PR on leakage				1	$\mu\text{A}$
<b>SWITCH DYNAMIC CHARACTERISTICS</b>						
$PSR_{217}$	Power supply rejection, $R_L = 5\ \Omega$ (see <a href="#">Figure 7</a> )	$V = 200\text{ mV}_{PP}, f = 217\text{ Hz}$		-100		dB
$PSR_{1k}$		$V = 200\text{ mV}_{PP}, f = 1\text{ kHz}$		-80		dB
$PSR_{20k}$		$V = 200\text{ mV}_{PP}, f = 20\text{ kHz}$		-50		dB
$ISO_{S1}$	SLEEVE_SENSE or RING2_SENSE to MICP Isolation (see <a href="#">Figure 8</a> )	$V = 200\text{ mV}_{PP}, f = 20\text{ kHz}, R_L = 50\ \Omega$		-100		dB
$SEP_{S1}$	SLEEVE_SENSE to RING2_SENSE Separation	$V = 200\text{ mV}_{PP}, f = 20\text{ kHz}, R_L = 50\ \Omega$ (see <a href="#">Figure 9</a> )		-60		dB
$THD_{200}$	Total Harmonic Distortion (see <a href="#">Figure 10</a> )	$V = 200\text{mV}_{PP}, f = 20\text{-}20\text{ kHz}, R_S = 600\ \Omega$		0.003		%
$THD_{500}$		$V = 500\text{mV}_{PP}, f = 20\text{-}20\text{kHz}, R_S = 600\ \Omega$		0.002		%
$t_{BBM}$	Break-Before-Make Off Time	Default		30		$\mu\text{s}$
		BBM register bit = 1'b1		60		$\mu\text{s}$
$t_{DETC}$	Detection sequence duration			360	500	ms

## I<sup>2</sup>C INTERFACE TIMING REQUIREMENTS

Unless otherwise noted the specification applies over the  $V_{DD}$  range and operating junction temp  $-40^{\circ}\text{C} \leq T_J \leq 70^{\circ}\text{C}$ .

PARAMETER		STANDARD MODE I <sup>2</sup> C BUS		FAST MODE I <sup>2</sup> C BUS		UNIT
		MIN	MAX	MIN	MAX	
$f_{scl}$	I <sup>2</sup> C clock frequency	0	100	0	400	kHz
$t_{sch}$	I <sup>2</sup> C clock high time	4		0.6		$\mu\text{s}$
$t_{scl}$	I <sup>2</sup> C clock low time	4.7		1.3		$\mu\text{s}$
$t_{sp}$	I <sup>2</sup> C spike time		50		50	ns
$t_{sds}$	I <sup>2</sup> C serial-data setup time	250		100		ns
$t_{sdh}$	I <sup>2</sup> C serial-data hold time	0		0		ns
$t_{icr}$	I <sup>2</sup> C input rise time		1000	21	300	ns
$t_{icf}$	I <sup>2</sup> C input fall time		300	21	300	ns
$t_{ocf}$	I <sup>2</sup> C output fall time ( $C_L = 10\text{ pF}$ to $400\text{ pF}$ )		300	$20+0.1C_b^{(1)}$	300	ns
$t_{bus}$	I <sup>2</sup> C bus free time between Start and Stop conditions	4.7		1.3		$\mu\text{s}$
$t_{sts}$	I <sup>2</sup> C Start or repeat Start condition setup	4.7		0.6		$\mu\text{s}$
$t_{sth}$	I <sup>2</sup> C Start or repeat Start condition hold	4		0.6		$\mu\text{s}$
$t_{sps}$	I <sup>2</sup> C Stop condition setup	4		0.6		$\mu\text{s}$
$t_{vd(data)}$	SCL low to SDA output valid		1		1	$\mu\text{s}$
$t_{vd(ack)}$	Valid-data time, ACK from SCL low to SDA low		1		1	$\mu\text{s}$
$C_b$	I <sup>2</sup> C bus load	0	400	0	400	pF

(1)  $C_b$  = total capacitance of one bus line in pF.

PARAMETER MEASUREMENT INFORMATION

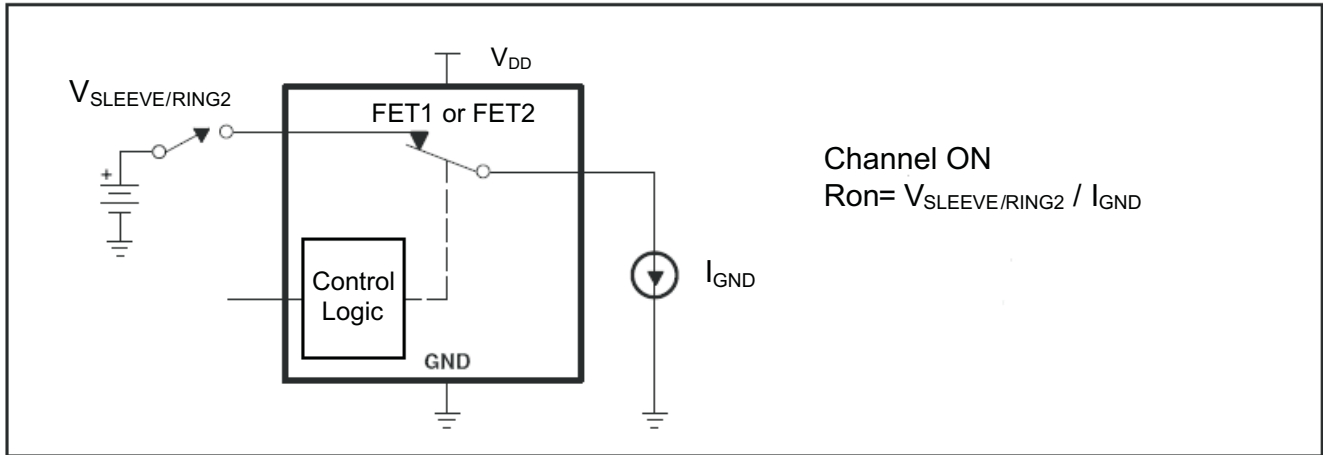

Figure 3. FET1/FET2 On Resistance Measurement

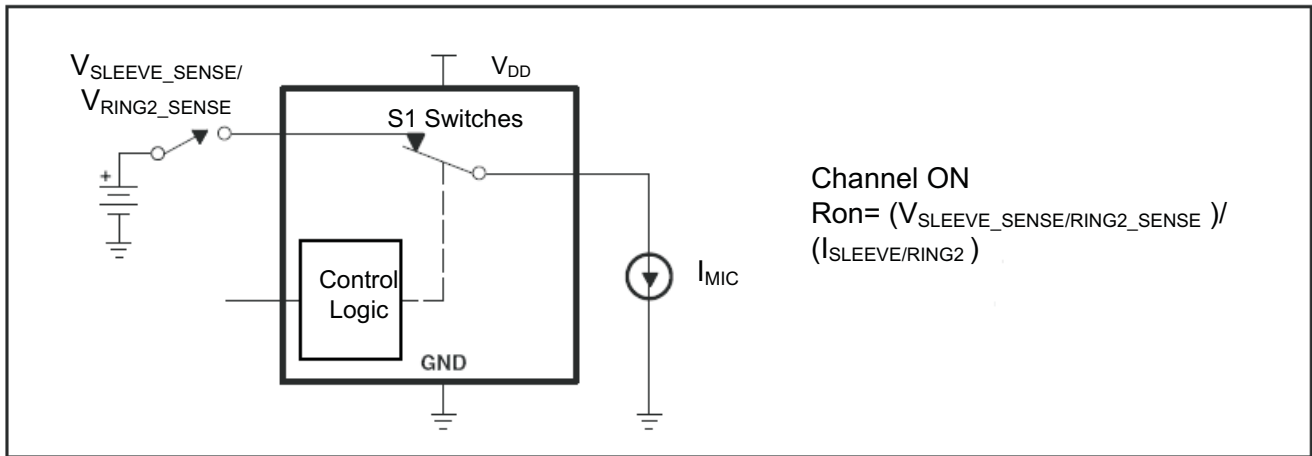

Figure 4. S1 Switch On Resistance Measurement

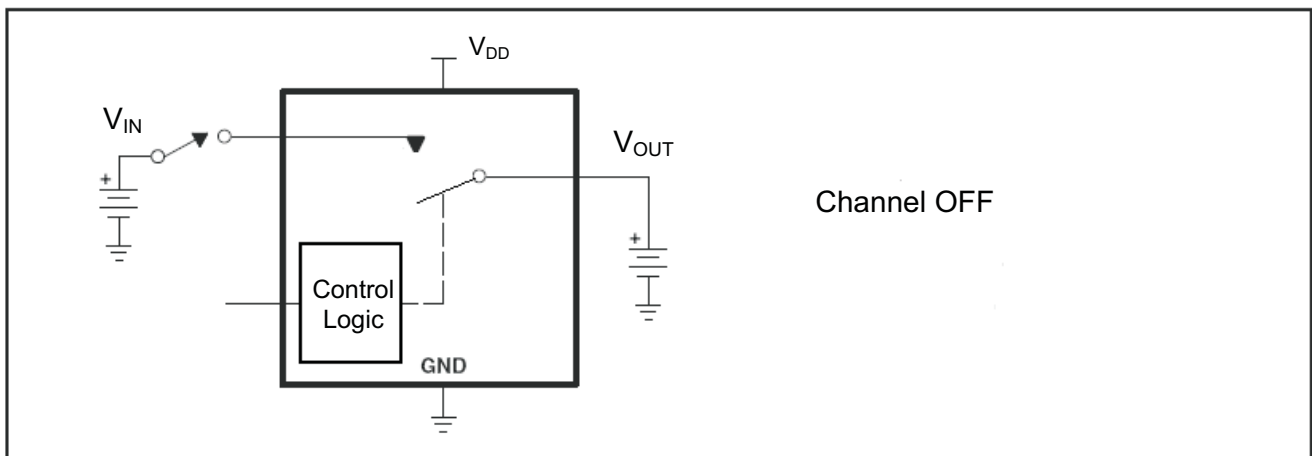

Figure 5. Switch Off Leakage Current Measurement

PARAMETER MEASUREMENT INFORMATION (continued)

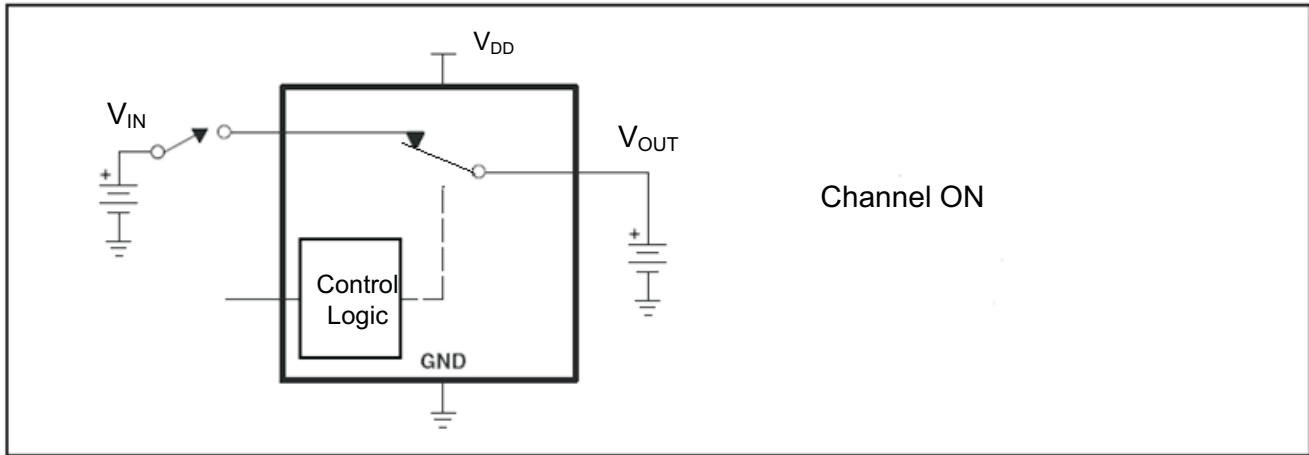

Figure 6. Switch On Leakage Current Measurement

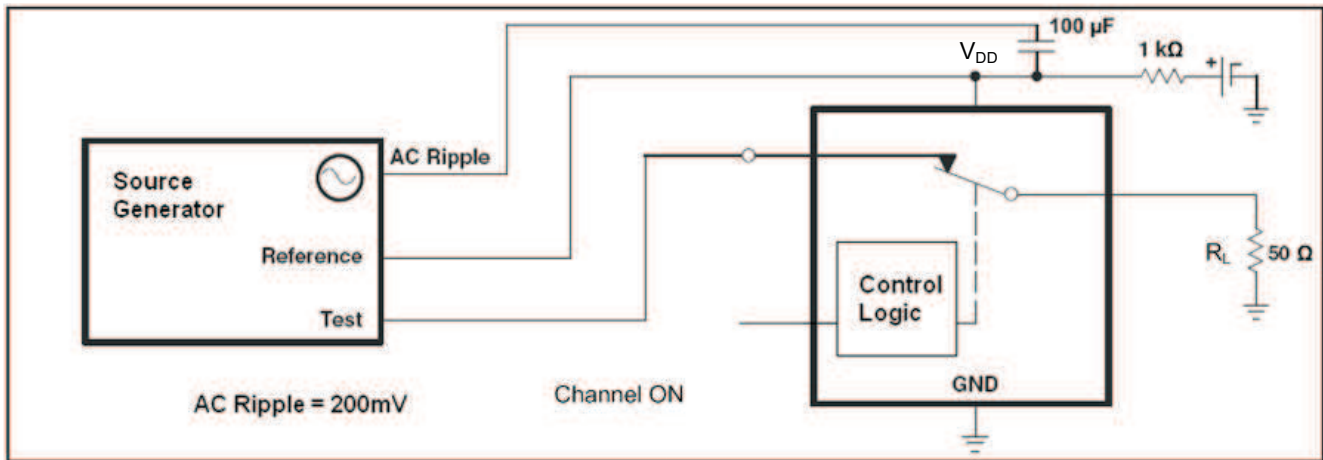

Figure 7. Power Supply Rejection Ratio (PSRR)

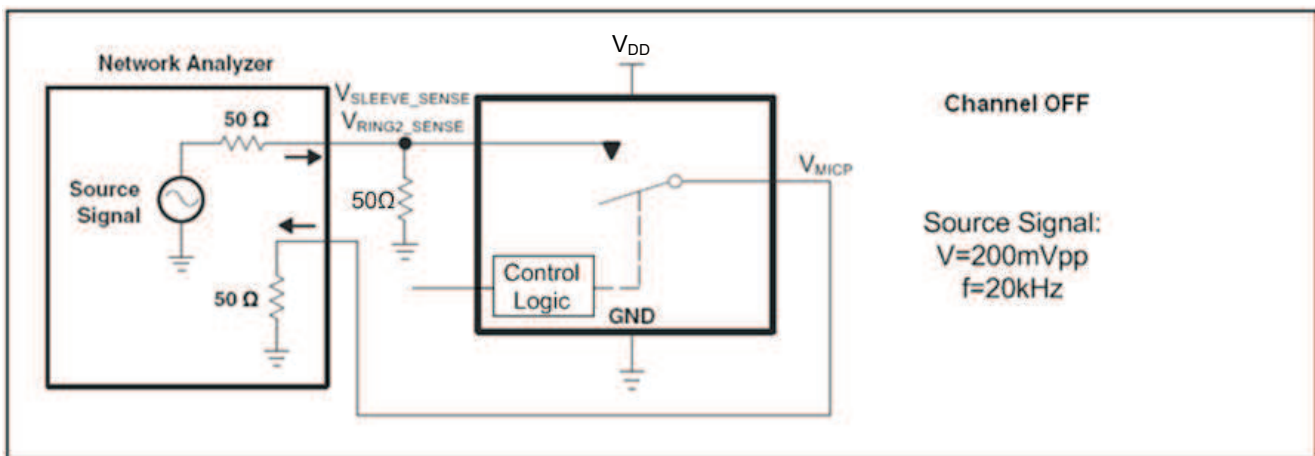

Figure 8. OFF-Isolation

PARAMETER MEASUREMENT INFORMATION (continued)

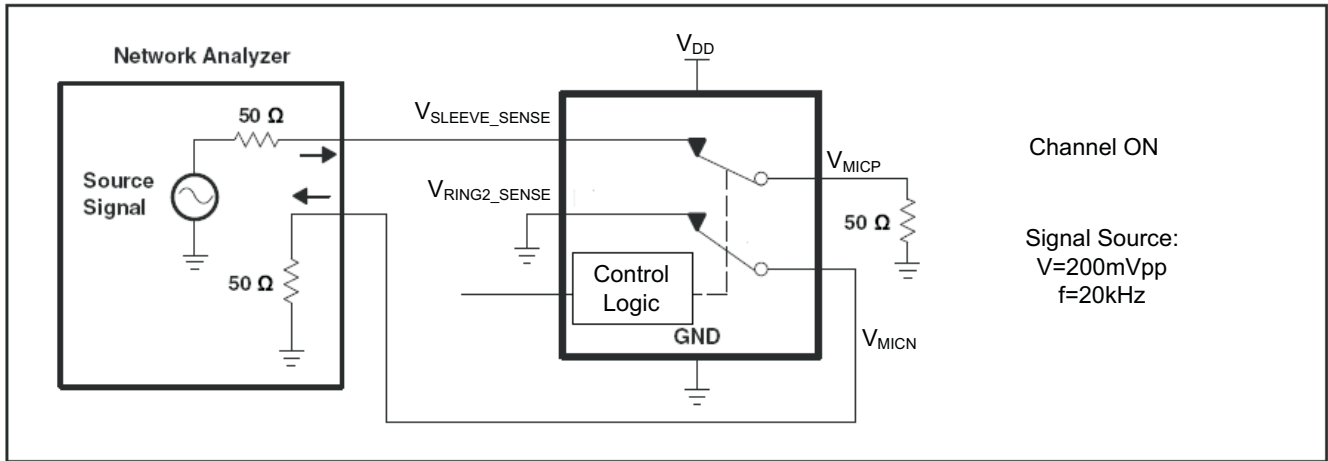
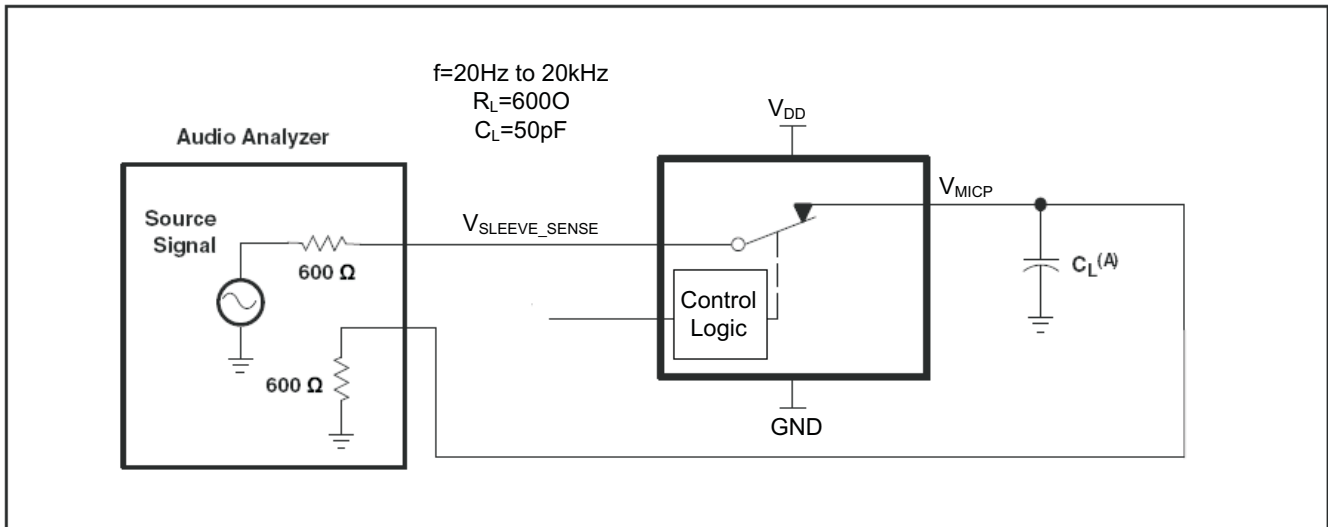

Figure 9. Channel Separation



A.  $C_L$  includes probe and jig capacitance.

Figure 10. Total Harmonic Distortion (THD)

PARAMETER MEASUREMENT INFORMATION (continued)

GND FET On Resistance

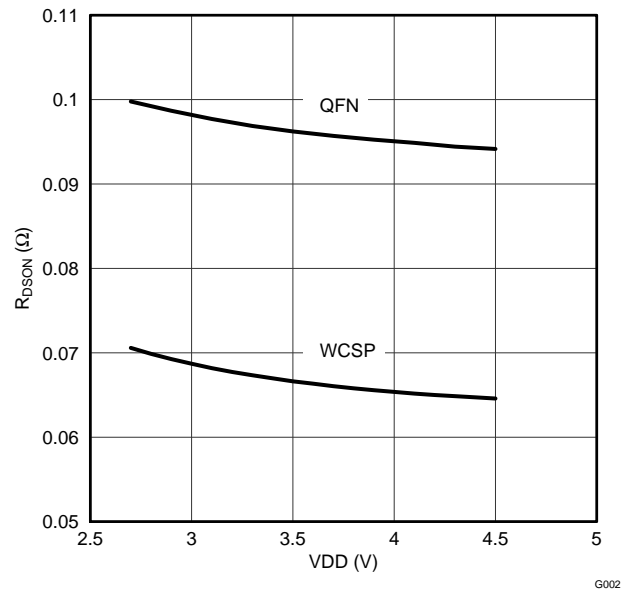

Figure 11. GND FET On Resistance

## DESCRIPTION OF OPERATION

### GENERAL OPERATION

The TS3A225E is an audio headset switch device that detects the existence and polarity of a microphone connected to a headset. Upon detection of a microphone the TS3A225E automatically connects a system analog microphone pin to the appropriate audio jack connection. The device also routes the system microphone GND to the proper jack connection.

The detection sequence is initiated via I<sup>2</sup>C command or the external trigger detection (DET\_TRIGGER) pin. The automatic routing feature can be disabled by I<sup>2</sup>C command. Additionally, all the switches of TS3A225E can be manually controlled by I<sup>2</sup>C register. See the I<sup>2</sup>C register usage section for details.

### EXTERNAL PIN CONNECTION

#### (1) HARDWARE MODE

The TS3A225E can be used in a non- I<sup>2</sup>C system in which the controls are performed via external pins. The following table summarizes how the external pins should be connected in a non- I<sup>2</sup>C system:

PIN	CONNECT TO	DETAILED DESCRIPTION
SCL/SDA	V <sub>DD</sub>	In a non- I <sup>2</sup> C system, these two pins should be tied directly to V <sub>DD</sub> to emulate the default state in an I <sup>2</sup> C commutation protocol.
I2C_ADDR_SEL	V <sub>DD</sub> or GND	In a non- I <sup>2</sup> C system this pin has no use and should be grounded.
/MIC_Present	None	This is an output pin and can be read to check whether microphone is detected. This pin will be driven low upon microphone detection.
DET_TRIGGER	Rising edge initiates detection	In a non- I <sup>2</sup> C system, this pin needs to be manually asserted to initiate a headset detection sequence. A rising edge on this pin triggers the detection.

#### (2) I<sup>2</sup>C Mode

In an I<sup>2</sup>C system, the external pins should be connected as follows:

PIN	CONNECT TO	NOTE													
SCL/SDA	I <sup>2</sup> C buses	SCL/SDA pins should be connected to the corresponding I2C buses in an I2C system													
I2C_ADDR_SEL	V <sub>DD</sub> or GND	This pin is used to modify the device I2C address in an I2C system to avoid address conflict. The address can be changed as follows: <table border="1" data-bbox="701 1268 1279 1470" style="margin-left: auto; margin-right: auto;"> <thead> <tr> <th>I2C_ADDR_SEL Pin</th> <th>Address</th> <th>Read/Write</th> </tr> </thead> <tbody> <tr> <td rowspan="2">0*</td> <td>8'h76</td> <td>Write</td> </tr> <tr> <td>8'h77</td> <td>Read</td> </tr> <tr> <td rowspan="2">1</td> <td>8'h78</td> <td>Write</td> </tr> <tr> <td>8'h79</td> <td>Read</td> </tr> </tbody> </table> <p style="text-align: center;">*This is the factory programmed value</p>	I2C_ADDR_SEL Pin	Address	Read/Write	0*	8'h76	Write	8'h77	Read	1	8'h78	Write	8'h79	Read
I2C_ADDR_SEL Pin	Address	Read/Write													
0*	8'h76	Write													
	8'h77	Read													
1	8'h78	Write													
	8'h79	Read													
/MIC_Present	None	By default, this is an output pin. This pin will be driven low upon microphone detection and will remain low until another detection event. In an I <sup>2</sup> S system, this pin can also serve as interrupt for I2C register update. See the I <sup>2</sup> C register usage section for more details.													
DET_TRIGGER	Rising edge initiates detection	In an I <sup>2</sup> C system, detection sequence can be initiated via the I2C DET_TRIGGER register or this DET_TRIGGER external pin. A rising edge on this pin triggers the detection.													

### MICROPHONE PRESENT INDICATOR

The TS3A225E detects whether or not a microphone is present on an inserted audio stereo jack. If a microphone is detected, the TS3A225E pulls the /MIC\_PRESENT pin low and also indicates the presence of the microphone in an I<sup>2</sup>C register. The /MIC\_PRESENT connection is an open-drain output with a maximum on resistance of 25 Ω. This makes the /MIC\_PRESENT pin compatible with HDA standards (if /MIC\_PRESENT is asserted low when connected to an external 5.1 kΩ pull-up resistor, the effective series resistance of the MIC\_PRESENT transistor + pull-up resistor will be changed by less than 0.5%).

The /MIC\_PRESENT pin can also be used as an interrupt flag in I<sup>2</sup>S based systems. The pin can be programmed via I<sup>2</sup>C to pull low when a microphone is present (the pin's default function), to act as an I<sup>2</sup>C interrupt when a microphone is detected, or it can be completely disabled.

## MICROPHONE POLARITY DETECTION

Microphone polarity is automatically detected by the TS3A225E when running the diagnostic sequence. Microphone polarity is accurately detected under all common connection scenarios for the TIP\_SENSE pin including a GND centered amplifier, a non-GND centered (AC-coupled) amplifier, or an amplifier with a tri-stated output.

Microphone detection is not guaranteed if either TIP or RING1 are transmitting audio signals during the detection sequence. To assure proper detection, do not output audio from the headphone amplifier until detection sequence is complete (500 ms after insertion).

It should also be noted that this device is backward compatible with headsets that include send/end functions. However, it should be specified that the user not to hold down the send/end button while the headset is being plugged since it may cause inaccurate microphone detection and the headset may need to be re-plugged.

Microphone polarity is defined by impedance to system GND as noted in the table below in a 4-prong headset:

Connection	Impedance to GND ( $\Omega$ )
R (Ring1)	16 ~ 1500
L (Tip)	16 ~ 1500
Mic (Ring2 or Sleeve)	600 ~ 3000

## SWITCH MANUAL CONTROL

In addition to fully automatic switching (the default mode), the TS3A225E's switches can also be manually controlled for increased flexibility. All switches are open by default, and each switch can be controlled individually via the CTRL2 register setting or based on one of the preset modes used in the CTRL1 register. The following outline the proper steps to perform manual switching:

**Step 1:** Disable auto switching by setting AUTO\_SW\_DIS in CTRL3 to 1.

**Step 2:** Change /Mic\_present bit to I<sup>2</sup>C interrupt by setting I2C\_INT register in CTRL3 to 1.

**Step 3:** Initialize detection by asserting the DET\_TRIGGER register or the DET\_TRIGGER external pin. After detection, the DAT1 registers store the detection result and they can be read to get the headset information. CTRL1 will stay in isolation mode '000' after detection since auto switching has been disabled.

**Step 4:** Manually control the switches by using one of the preset modes in CTRL1 ('010' to '110') or change the mode of CTRL1 to '111' to control each switch individually based on CTRL2 register settings. The /MIC\_PRESENT pin can be manually pulled down by setting **b4** of the CTRL3 register to '1'.

## STANDARD I2C INTERFACE DETAILS

The bidirectional I<sup>2</sup>C bus consists of the serial clock (SCL) and serial data (SDA) lines. Both lines must be connected to a positive supply via a pull-up resistor when connected to the output stages of a device. Data transfer may be initiated only when the bus is not busy.

I<sup>2</sup>C communication with this device is initiated by the master sending a START condition, a high-to-low transition on the SDA input/output while the SCL input is high (see ). After the start condition, the device address byte is sent, MSB first, including the data direction bit (R/W). This device does not respond to the general call address. After receiving the valid address byte, this device responds with an ACK, a low on the SDA input/output during the high of the ACK-related clock pulse.

The data byte follows the address ACK. The R/W bit is kept low for transfer from the master to the slave. The data byte is followed by an ACK sent from this device. Data are output only if complete bytes are received and acknowledged. The output data is valid at time (tpv) after the low-to-high transition of SCL, during the clock cycle for the ACK.

On the I<sup>2</sup>C bus, only one data bit is transferred during each clock pulse. The data on the SDA line must remain stable during the high pulse of the clock period, as changes in the data line at this time are interpreted as control commands (START or STOP) (see ).

A Stop condition, a low-to-high transition on the SDA input/output while the SCL input is high, is sent by the master (see Figure ). The number of data bytes transferred between the start and the stop conditions from transmitter to receiver is not limited. Each byte of eight bits is followed by one ACK bit. The transmitter must release the SDA line before the receiver can send an ACK bit.

A slave receiver that is addressed must generate an ACK after the reception of each byte. The device that acknowledges has to pull down the SDA line during the ACK clock pulse so that the SDA line is stable low during the high pulse of the ACK-related clock period (see Figure 12). Setup and hold times must be taken into account.

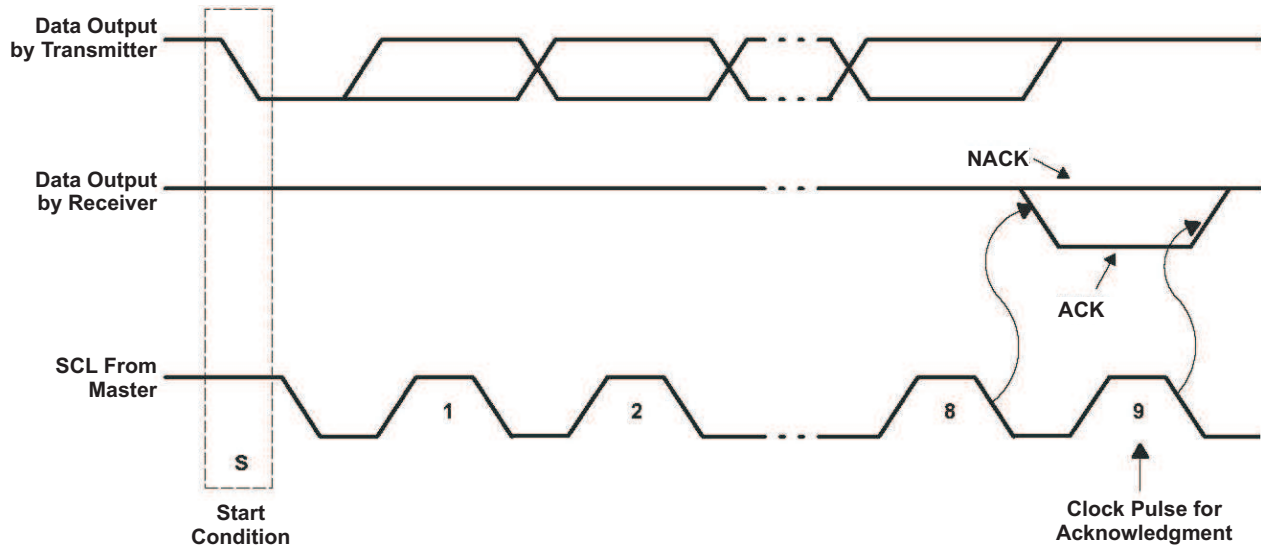

Figure 12. Acknowledgment on I<sup>2</sup>C Bus

### WRITES OPERATION

Data is transmitted to the TS3A225E by sending the device slave address and setting the LSB to a logic 0. The command byte is sent after the address and determines which register receives the data that follows the command byte. The next byte is written to the specified register on the rising edge of the ACK clock pulse. See Figure 13 and Figure 14 for the two modes of Write operations.

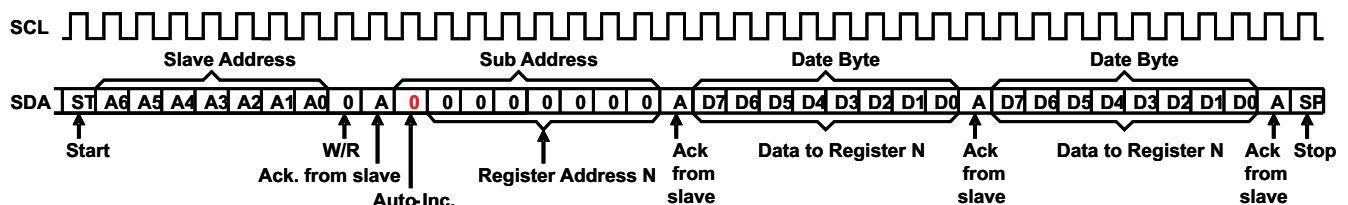

Figure 13. Repeated Data Write to a Single Register

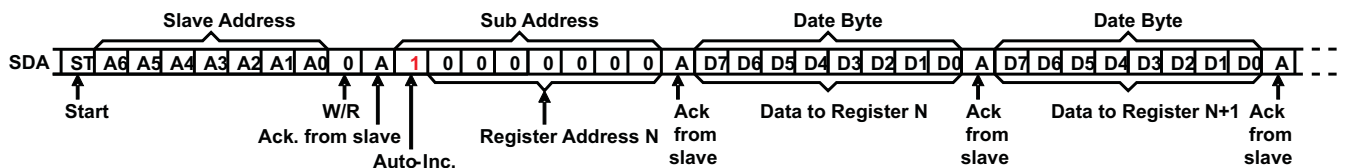

Figure 14. Burst Data Write to Multiple Registers

## READS OPERATION

The bus master first send the TS3A225E slave address with the LSB set to logic 0. The command byte is sent after the address and determines which register is accessed. After a restart, the device slave address is sent again but, this time, the LSB is set to logic 1. Data from the register defined by the command byte then is sent by the TS3A225E. Data is clocked into the SDA output shift register on the rising edge of the ACK clock pulse. See Figure 15 to Figure 18 for different modes of Reads Operation.

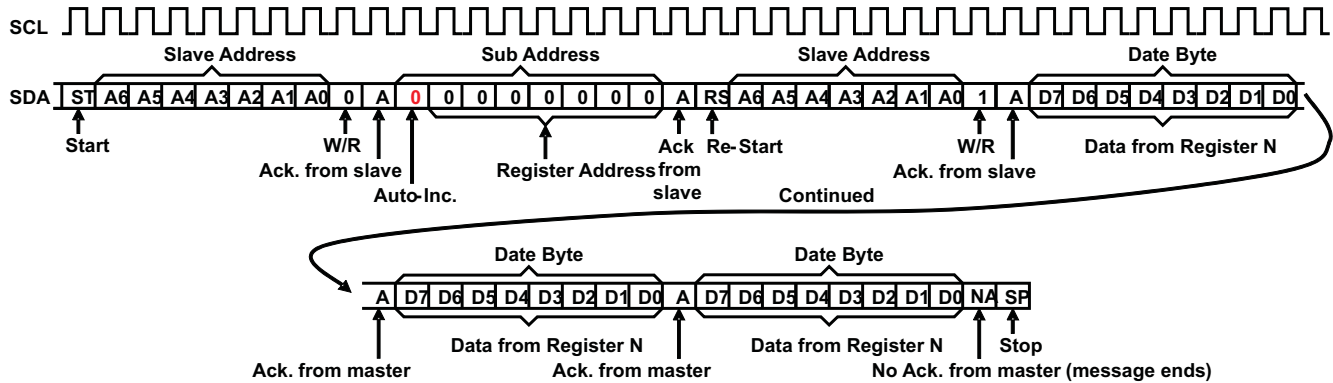

Figure 15. Repeated Data Read from a Single Register – Combined Mode

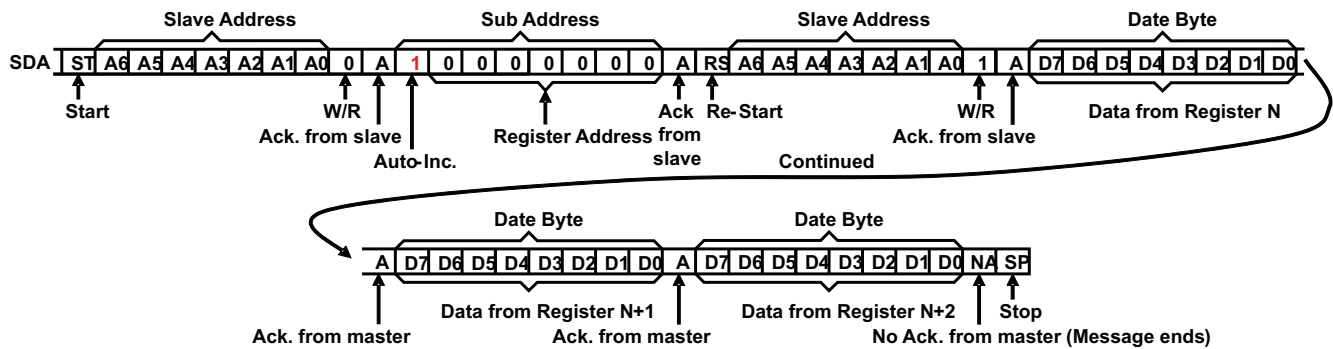

Figure 16. Burst Data Read from Multiple Registers – Combined Mode

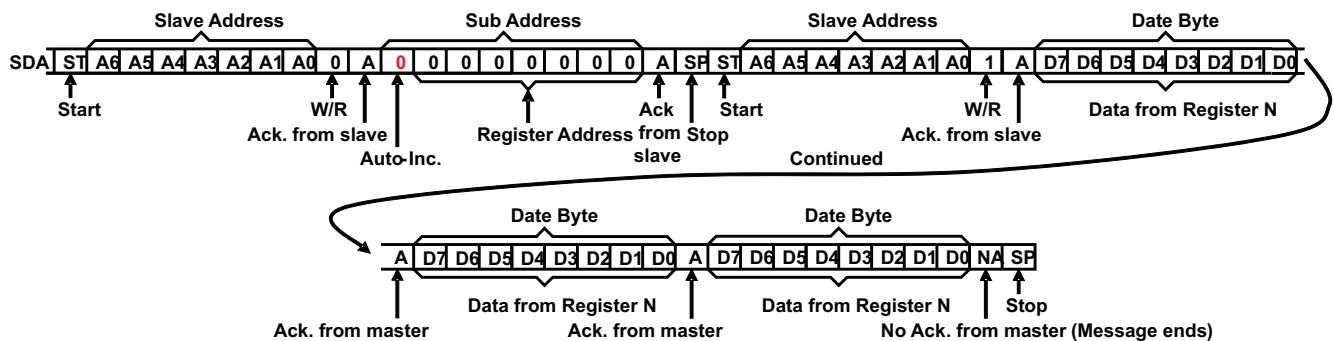

Figure 17. Repeated Data Read from a Single Register – Split Mode

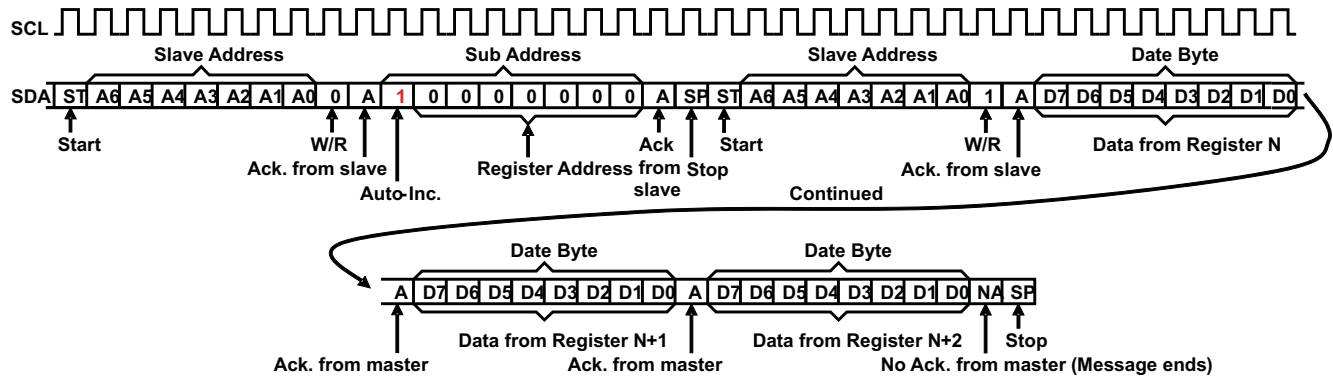

Figure 18. Burst Data Read from Multiple Registers – Split Mode

Notes:

1. SDA is pulled low on Ack. from slave or Ack. from master.
2. Register writes always require sub-address write before first data byte.
3. Repeated data writes to a single register continue indefinitely until Stop or Re-Start.
4. Repeated data reads from a single register continue indefinitely until No Ack. from master.
5. Burst data writes start at the specified register address, then advance to the next register address, even to the read-only registers and continue until Stop or Re-Start. For the read-only registers, data write appears to occur, though no data are changed by the writes.
6. Burst data reads start at the specified register address, then advance to the next register address and continues until No Ack. from master.

REGISTER MAP

Addr (xxh)	Name	Type	Reset Value	b7	b6	b5	b4	b3	b2	b1	b0
0x01	ID	R	NA								
0x02	CTRL1	R/W	0x00					BBM		MODE[2:0]	
0x03	CTRL2	R/W	0x00	S1NR	S1NS	S1PR	S1PS			FET1	FET2
0x04	CTRL3	R/W	0x00				/MIC_PRESENT MANUAL	DET_TRIG_DIS	I2C_INT	AUTO_DET_DIS	DET_TRIGGER
0x05	DAT1	R	0x00		GND_LOC		SLEEVE_Z[2:0]			RING2_Z[2:0]	
0x06	INT	R	0x00					DET_ERROR		MIC_PRESENT	STD_TSR
0x07	INT Mask	R/W	0x00				I2C_INT MASK	DET_ERROR MASK		MIC_PRESENT MASK	STD_TSR MASK

REGISTER DESCRIPTION

1. ID

Address : 0x01      Reset Value : N/A      Type : Read

NAME	SIZE(BITS)	DESCRIPTION
Device ID	8	Unique Revision Number

**2. CTRL1**
**Address : 0x02      Reset Value : 0x00      Type : Read and Write**

NAME	SIZE(BITS)	DESCRIPTION	Data [7:0]
RESERVED	4		
BBM	1	0: Disable break-before-make functionality	xxxx0xxx
		1: Enable break-before-make functionality	xxxx1xxx
MODE	3	000: Isolation. All Switch open. This is the default state.	xxxxx000
		001: Reserved	xxxxx001
		010: Normal Single Ended (FET1, S1NR, S1PS closed)	xxxxx010
		011: Reverse Single Ended (FET2, S1NS, S1PR closed)	xxxxx011
		100: Normal Differential (S1NR, S1PS closed)	xxxxx100
		101: Reversed Differential (S1NS, S1PR closed)	xxxxx101
		110: 3Prong (FET1, FET2, S1NS, S1NR closed)	xxxxx110
		111: Manual (I2C mode) with all switches open. Switch position controlled via CTRL2	xxxxx111

**3. CTRL2**
**Address : 0x03      Reset Value : 0x00      Type : Read and Write**

NAME	SIZE(BITS)	DESCRIPTION	Data [7:0]
S1NR	1	0: S1NR Switch Disabled when MODE[2:0] = 3'b111 in CTRL1	0xxxxxxx
		1: S1NR Switch Enabled when MODE[2:0] = 3'b111 in CTRL1	1xxxxxxx
S1MS	1	0: S1NS Switch Disabled when MODE[2:0] = 3'b111 in CTRL1	x0xxxxxx
		1: S1NS Switch Enabled when MODE[2:0] = 3'b111 in CTRL1	x1xxxxxx
S1PR	1	0: S1PR Switch Disabled when MODE[2:0] = 3'b111 in CTRL1	xx0xxxxx
		1: S1PR Switch Enabled when MODE[2:0] = 3'b111 in CTRL1	xx1xxxxx
S1PS	1	0: S1PS Switch Disabled when MODE[2:0] = 3'b111 in CTRL1	xxx0xxxx
		1: S1PS Switch Enabled when MODE[2:0] = 3'b111 in CTRL1	xxx1xxxx
Reserved	2		
FET1	1	0: FET1 Disabled when MODE[2:0] = 3'b111 in CTRL1	xxxxxx0x
		1: FET1 Enabled when MODE[2:0] = 3'b111 in CTRL1	xxxxxx1x
FET2	1	0: FET2 Disabled when MODE[2:0] = 3'b111 in CTRL1	xxxxxxx0
		1: FET2 Enabled when MODE[2:0] = 3'b111 in CTRL1	xxxxxxx1

**4. CTRL3**
**Address : 0x041      Reset Value : 0x00      Type : Read and Write**

NAME	SIZE(BITS)	DESCRIPTION	Data [7:0]
Reserved	3		
/MIC_PRESENT MANUAL	1	0: Default 1: Set this bit to 1 manually pull the /MIC_PRESENT output low	xxx0xxxx Xxx1xxxx
DET_TRIG_DIS	1	0: Enables initiation of a detect sequence through the external DET_TRIGGER pin (default) 1: Disables initiation of a detect sequence through the external DET_TRIGGER pin	xxxx0xxx xxxx1xxx
I2C_INT	1	0: /MIC_PRESENT pin used to indicate presence of microphone on output (default) 1: /MIC_PRESENT pin serves as interrupt for I2C register updates	xxxxx0xx xxxxx1xx
AUTO_SW_DIS	1	0: Enables auto switching after detection (default) 1: Disables auto switching after detection	xxxxxx0x xxxxxx1x
DET_TRIGGER	1	0: default 1: Initiates a detection through I2C control*	xxxxxxx0 xxxxxxx1

**5. DAT1**

**Address : 0x05      Reset Value : 0x00      Type : Read and Write**

NAME	SIZE(BITS)	DESCRIPTION	Data [7:0]
Reserved	1		
GND_LOC	1	0: GND Segment is located on Ring2 band	x0xxxxxx
		1: GND Segment is located on Sleeve band	x1xxxxxx
SLEEVE_Z	3	000: Impedance between Tip and Sleeve is <400Ω	xx000xxx
		001: 400Ω ≤ Impedance between Tip and Sleeve <800Ω	xx001xxx
		010: 800Ω ≤ Impedance between Tip and Sleeve <1200Ω	xx010xxx
		011: 1200Ω ≤ Impedance between Tip and Sleeve <1600Ω	xx011xxx
		100: 1600Ω ≤ Impedance between Tip and Sleeve <2000Ω	xx100xxx
		101: 2000Ω ≤ Impedance between Tip and Sleeve <2400Ω	xx101xxx
		110: 2400Ω ≤ Impedance between Tip and Sleeve <2800Ω	xx110xxx
		111: Impedance between Tip and Sleeve ≥ 2800 Ω	xx111xxx
RING2_Z	3	000: Impedance between Tip and Ring2 <400Ω	xxxxx000
		001: 400Ω ≤ Impedance between Tip and Ring2 <800Ω	xxxxx001
		010: 800Ω ≤ Impedance between Tip and Ring2 <1200Ω	xxxxx010
		011: 1200Ω ≤ Impedance between Tip and Ring2 <1600Ω	xxxxx011
		100: 1600Ω ≤ Impedance between Tip and Ring2 <2000Ω	xxxxx100
		101: 2000Ω ≤ Impedance between Tip and Ring2 <2400Ω	xxxxx101
		110: 2400Ω ≤ Impedance between Tip and Ring2 <2800Ω	xxxxx110
		111: Impedance between Tip and Ring2 ≥ 2800 Ω	xxxxx111

**6. INT**

**Address : 0x06      Reset Value : 0x00      Type : Read**

NAME	SIZE(BITS)	DESCRIPTION	Data [7:0]
Reserved	4		
DET_ERROR	1	0: default	xxxx0xxx
		1: Detection sequence completed without successful detection of either a standard plug or a plug with MIC	xxxx1xxx
Reserved	1		
MIC_PRESENT	1	0: default	xxxxxx0x
		1: A microphone detected on either RING2 or SLEEVE	xxxxxx1x
STD_TSR	1	0: default	xxxxxxx0
		1: A standard TSR headset detected, RING2 and SLEEVE shorted	xxxxxxx1

**7. INT MASK**

**Address : 0x07      Reset Value : 0x00      Type : Read and Write**



NAME	SIZE(BITS)	DESCRIPTION	Data [7:0]
Reserved	3		
I2C_INT_MASK	1	0: default	xxx0xxxx
		1: Tri-state /MIC_PRESENT pin	xxx1xxxx
DET_ERROR MASK	1	0: default	xxxx0xxx
		1: Mask DET_ERROR from setting an I2C interrupt	xxxx1xxx
Reserved	1		
MIC_PRESENT MASK	1	0: default	xxxxxx0x
		1: Mask MIC_PRESENT from setting an I2C interrupt	xxxxxx1x
STD_TSR MASK	1	0: default	xxxxxxx0
		1: Mask STD_TSR from setting an I2C interrupt	xxxxxxx1

APPLICATION INFORMATION

APPENDIX: TS3A225E APPLICATION GUIDELINE

The TS3A225E is an audio headset switch device. The device detects the presence of an analog microphone and switches a system analog microphone pin between different connectors in an audio stereo jack. There are two different headset connector configurations currently available: TRS and TRRS. The TRS is comprised of a tip, ring, and sleeve connections while the TRRS contains a tip, ring1, ring2, and sleeve connections. The additional ring connection in the TRRS provides a microphone connection to the headset. Currently, there are two configurations for the TRRS: the Standard and OMTP (Open Mobile Terminal Platform) headsets. The difference between these two configurations is that the GND and Microphone bands are switched. Table 1 below depicts the differences between the TRS and the 2 types of TRRS headsets and their range of internal impedance values between the bands.

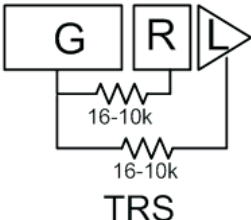
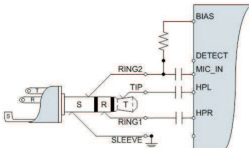
Table 2. Headset Configuration

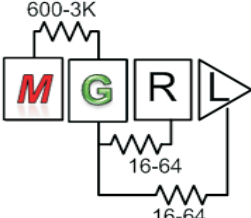
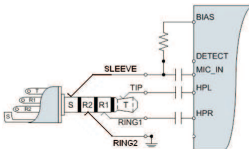
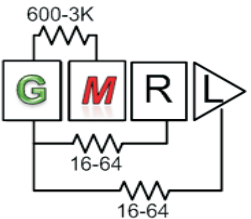
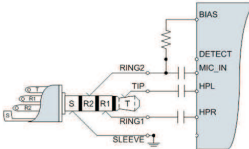
Physical Connector	Internal Impedance	Pin Configuration		Connector Structure	
		Pin Name	Configuration		
 <p>TRS</p>	 <p>TRS</p>	Tip	Audio Left		
		Ring	Audio Right		
		Sleeve	Ground		
 <p>TRRS</p>	 <p>Standard (Apple, HTC, RIM)</p>	Tip	Audio Left		
		Ring 1	Audio Right		
		Ring 2	Ground		
		 <p>OMTP (Nokia, Motorola, SEMC)</p>	Sleeve	Microphone	
			Tip	Audio Left	
			Ring 2	Audio Right	
		Ring 2	Ground		
		Sleeve	Microphone		

The TS3A225E detects one of the configurations above by going through a series of impedance detection steps. The device automatically connects the microphone line to the appropriate pin after the detection result becomes available. The device also routes the system microphone GND to the proper jack connection to establish appropriate GND return path. Therefore, TS3A225E provides the capability to use one single universal headset jack to accept both types of microphone headsets.

**Reference Schematic**

The following figure (Figure 19) is the reference circuit that is recommended to be used to connect the TS3A225E between the audio combo jack and audio CODEC. Table 2 below listed the suggested passive components to be used in the system.

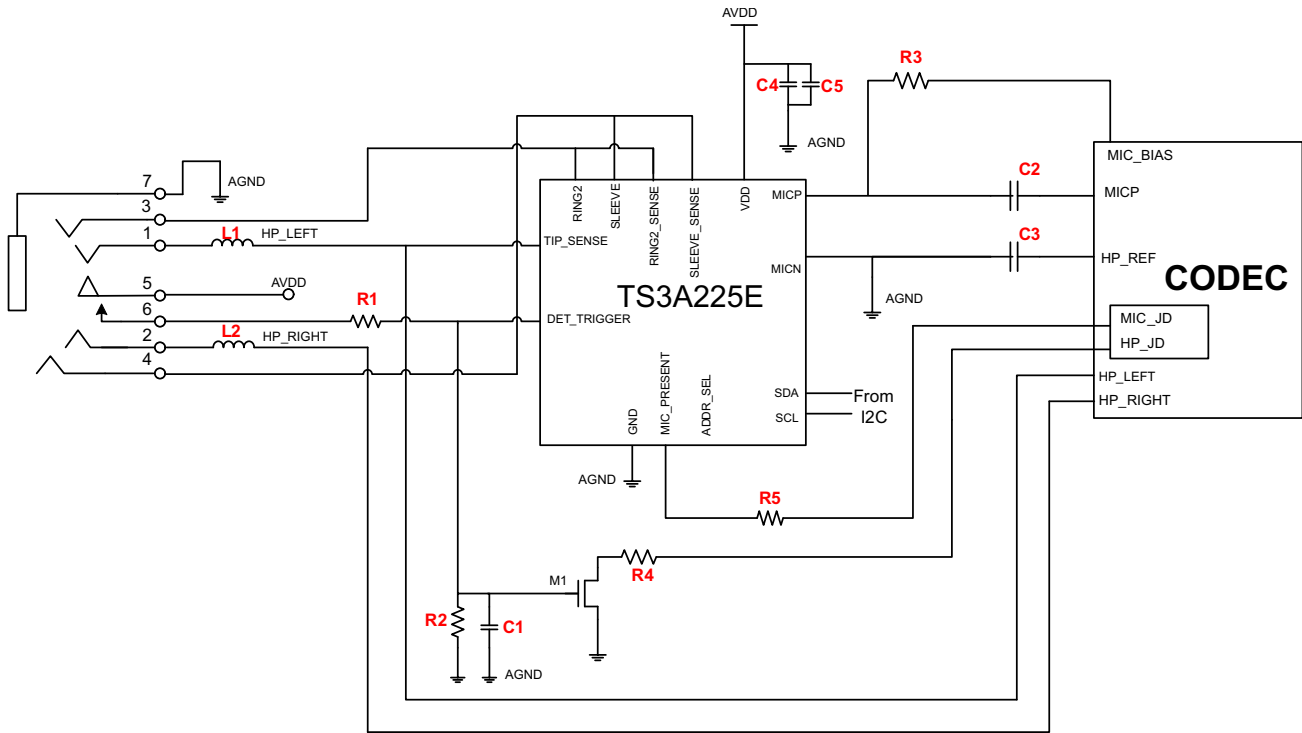

**Figure 19. TS3A225E Reference Schematic**

**Table 3. Components Description**

Capacitor	Value	Resistor	Value	Ferrite Bead	Value
C1	1 µF	R1	1 kΩ	L1, L2	N/A
C2	1 µF	R2	100 kΩ		
C3	1 µF	R3	2.2 kΩ		
C4	10 µF	R4	39.2 Ω		
C5	1 µF	R5	20 kΩ		

## Detailed Application Recommendation

The followings are the recommended usages for TS3A225E.

- To properly initiate the detection sequence of TS3A225E, the DET\_TRIGGER pin needs to be configured correctly. The detection is triggered with a low to high transition on the DET\_TRIGGER pin. To configure this function automatically through hardware, consider using an audio jack similar to the one shown in Figure 1 and connect pin 5 to VDD and pin 6 to GND through a 100k resistor. With this setup, the DET\_TRIGGER pin is normally pulled low without a headset plugged-in and goes high when jack is inserted. To smooth out the low-to-high transition and to mitigate “slow plug-in” issue (discussed in the next section), R and C are recommended to be added to the DET\_TRIGGER pin (R1 and C1). It’s recommended to have  $C1 > 1\mu\text{F}$ . The value of R1 can be adjusted depending on the audio jack used. A good default value to start with is  $1\text{k}\Omega$ .
- The DET\_TRIGGER signal can also be utilized to implement the headphone sense (HP\_JD) feature of the audio CODEC. When used together with a MOSFET (M1), this pin can be connected to the HP\_JD pin (or any other relevant pin) of the audio CODEC to indicate a headset has been plugged-in. The CODEC can then turn on the left and right channel audios after a specific amount of delay ( $>$  detection period of TS3A225E = 360ms). The value of R4 may change depending on CODEC used.
- The MIC\_PRESENT pin is an open-drain output and will be pulled low when a microphone is detected by TS3A225E. This pin can be connected directly to the MIC\_JD pin on the CODEC to indicate the system a microphone is connected. The value of R5 may change depending on the CODEC used.
- The SLEEVE and RING2 pins should be routed to the actual headset jack connections with low impedance traces (wide, short traces). SLEEVE\_SENSE and RING2\_SENSE should not use the same traces and they can be much narrower and higher in impedance as they will be fed into high impedance inputs looking into the CODEC. On the CODEC side of the switch, the MICn / HP\_REF connection should be fed into the HP\_REF input of the CODEC. Utilizing the HP\_REF input on CODECs typically improves cross talk by 10-15 dB. Not all CODECs have these inputs, but almost all newly released CODECs have this feature.
- The TIP\_SENSE pin goes to the left channel of the audio headphone (HP\_LEFT). The right channel does not go through the TS3A225E. Ferrite Beads (L1 and L2) are recommended on these 2 paths to filter out high frequency noises on the audio channels.
- Parallel 10uF and 1uF standard decoupling capacitor are recommended for the supply to decouple noises on the power rail.
- The SDA/SCL pins are connected to the I2C interfaces of the MCU. They maybe pulled up to VDD via resistors if no I2C control is needed. The ADDR\_SEL pin is a GPIO-controlled pin for changing TS3A225E’s slave address to avoid system address conflict. If this feature is not needed, ADDR\_SEL can be grounded.

### Special Note on Slow Headset Plug-In Issue

In real-world scenario a user might plug in the headset to the audio jack very slowly. This creates a challenging case for TS3A225E's detection mechanism and detection error might occur if care is not taken when designing the components around the TS3A225E. The main concern for slow plug-in is the detection process might have already begun before the headset gets fully inserted into the jack. If the detection is running with headset's plug out of position, the TS3A225E might retrieve false impedance information from the test and give incorrect detection result. To mitigate the slow plug-in issue, the following 3 steps can be implemented:

#### Jack Selection

Usage of proper audio jack in conjunction with TS3A225E is the most effective technique to alleviate the slow plug-in issue. One type of popular audio combo jack on the market has the pin composition similar to the one shown in Figure 20 below, where the DET\_TRIGGER mechanism has to be designed around the RING1 pin. While headset is being inserted, the tip of the headset touches the RING1 pin first, pushing out pin 5 to pin 6 and connect them together, generating a low-to-high transition on the DET\_TRIGGER pin and triggers the detection sequence of TS3A225E. However, the headset is not yet fully inserted at this moment (tip has not touched pin 1) and if the insertion is relatively slow the impedance detection of TS3A225E may complete before the tip of the headset touches pin 1. This may result in false impedance values read by TS3A225E and affects its proper switching mechanism.

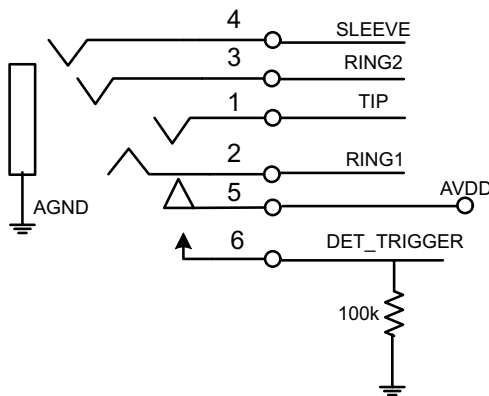

Figure 20. Poor Jack Usage

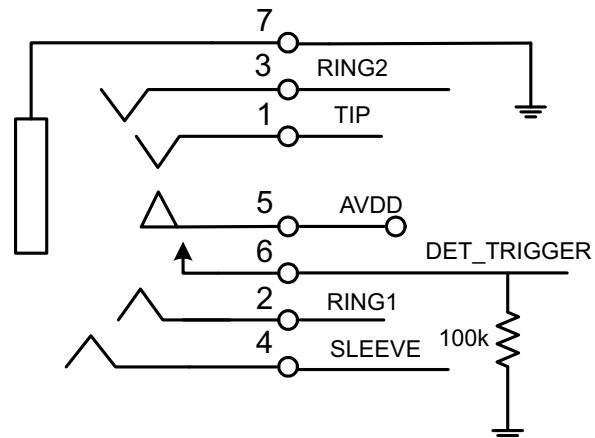

Figure 21. Recommended Audio Jack Selection

A more suitable audio jack to be used with TS3A225E is the one shown in Figure 21 above. This type of jack has the push-out mechanical structure located on the inner-most part of the jack. It thus allows the transition on DET\_TRIGGER pin to occur only after the headset has been fully inserted with the tip touching pin 1 and 5, which reduces the risk of early-triggering on TS3A225E's detection sequence.

#### RC Delay on DET\_TRIGGER

Another possible method to alleviate the slow-plug in issue is to introduce RC delay on the DET\_TRIGGER pin. As specified in the Reference Schematic (Figure 1) in the previous section, the combination of R1 and C1 produces a low-pass effect on the DET\_TRIGGER pin to slow down its transition from low to high. This delay provides more time for the headset to be fully inserted into the jack before the detection sequence of TS3A225E is triggered.

For effective delay implementation, it is recommended to use  $C1 > 1\mu\text{F}$ . The board layout space can be reserved for R1 and the value of R1 can be adjusted based on the actual measurement data. A good default value to start with is  $1\text{k}\Omega$ .

#### Internal Delay

The TS3A225E has built-in 120ms delay to address the slow plug-in issue. After the low-to-high transition on the DET\_TRIGGER pin, the TS3A225E does not start impedance detection sequence until 120ms later. This delay period gives some time buffer for the headset to be fully plugged-in.

### Special Note On Power Of Noise Issue

In computing, the Advanced Configuration and Power Interface (ACPI) specification provides an open standard for device configuration and power management by the operating system. The ACPI specification defines a number of different power states for an ACPI-compliant computer-system, ranging from G0 (system working) to G3 (system mechanical off with close to zero power consumption).

When TS3A225E is used in the ACPI-compliant computer-system, and if the user has a speaker (with amplifier) plugged into the audio jack when the system enters low-power state, audible noise interference may be heard during G1, G2, and G3 states. The G1, G2, and G3 states are defined as:

**G1:** Sleeping mode

**G2 (or S5) Soft Off:** G2 is almost the same as G3 Mechanical Off, but some components remain powered so the computer can "wake" from input from the keyboard, clock, modem, LAN, or USB device.

**G3: Mechanical Off:** The computer's power consumption approaches zero, to the point that the power cord can be removed and the system is safe for dis-assembly.

The root cause of this noise interference comes from the fact that the TS3A225E's VDD supply is disconnected during mode G1 to G3. The two Ground FET switches (FET1 and FET2) become open by default when no power is supplied to the device, and the ground return path lines become floating under this circumstance. With no established ground return path, the long speaker wire acts as an antenna and picks up random signals from the air and outputs the noise to the amplified speaker, creating undesirable buzzing noises.

To levitate this problem, the following circuitry is recommended:

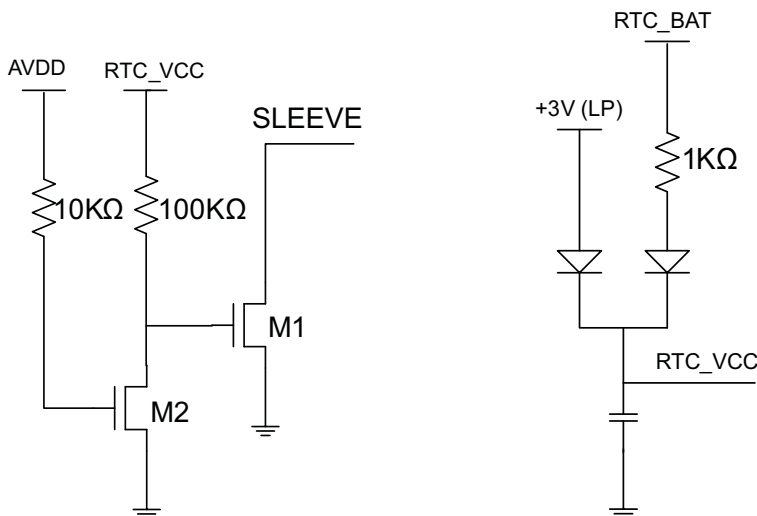

With the use of this circuitry, the SLEEVE pin will be pulled down to GND by the RTC\_VCC power source. The RTC\_VCC power source is generated by the Real Time Clock source running off a small on-board battery (RTC\_BAT) that is kept running even in G3 mode. With SLEEVE pin pulled down to GND, ground return path is established for the speaker and noises will be eliminated. Diodes are added from RTC\_BAT to +3V (LP) to prevent leakage when system is turning on.

During normal system operation, AVDD becomes available to turn on M2 and in turn shut off M1. The SLEEVE to GND path will then be controlled solely by the internal FET switches of TS3A225E.

## REVISION HISTORY

Changes from Original (August 2012) to Revision A	Page
• Added $V_{IO}$ and $V_{IO(TIP)}$ parameters to the RECOMMENDED OPERATING CONDITIONS. ....	7
• Deleted DETECTION SEQUENCE AND RESET section. ....	15

**PACKAGING INFORMATION**

Orderable Device	Status (1)	Package Type	Package Drawing	Pins	Package Qty	Eco Plan (2)	Lead finish/ Ball material (6)	MSL Peak Temp (3)	Op Temp (°C)	Device Marking (4/5)	Samples
TS3A225ERTER	ACTIVE	WQFN	RTE	16	3000	RoHS & Green	NIPDAU	Level-2-260C-1 YEAR	-40 to 85	ZTL	<a href="#">Samples</a>
TS3A225EYFFR	ACTIVE	DSBGA	YFF	16	3000	RoHS & Green	SNAGCU	Level-1-260C-UNLIM	-40 to 85	YP225E	<a href="#">Samples</a>

(1) The marketing status values are defined as follows:

**ACTIVE:** Product device recommended for new designs.

**LIFEBUY:** TI has announced that the device will be discontinued, and a lifetime-buy period is in effect.

**NRND:** Not recommended for new designs. Device is in production to support existing customers, but TI does not recommend using this part in a new design.

**PREVIEW:** Device has been announced but is not in production. Samples may or may not be available.

**OBSOLETE:** TI has discontinued the production of the device.

(2) **RoHS:** TI defines "RoHS" to mean semiconductor products that are compliant with the current EU RoHS requirements for all 10 RoHS substances, including the requirement that RoHS substance do not exceed 0.1% by weight in homogeneous materials. Where designed to be soldered at high temperatures, "RoHS" products are suitable for use in specified lead-free processes. TI may reference these types of products as "Pb-Free".

**RoHS Exempt:** TI defines "RoHS Exempt" to mean products that contain lead but are compliant with EU RoHS pursuant to a specific EU RoHS exemption.

**Green:** TI defines "Green" to mean the content of Chlorine (Cl) and Bromine (Br) based flame retardants meet JS709B low halogen requirements of <=1000ppm threshold. Antimony trioxide based flame retardants must also meet the <=1000ppm threshold requirement.

(3) MSL, Peak Temp. - The Moisture Sensitivity Level rating according to the JEDEC industry standard classifications, and peak solder temperature.

(4) There may be additional marking, which relates to the logo, the lot trace code information, or the environmental category on the device.

(5) Multiple Device Markings will be inside parentheses. Only one Device Marking contained in parentheses and separated by a "~" will appear on a device. If a line is indented then it is a continuation of the previous line and the two combined represent the entire Device Marking for that device.

(6) Lead finish/Ball material - Orderable Devices may have multiple material finish options. Finish options are separated by a vertical ruled line. Lead finish/Ball material values may wrap to two lines if the finish value exceeds the maximum column width.

**Important Information and Disclaimer:**The information provided on this page represents TI's knowledge and belief as of the date that it is provided. TI bases its knowledge and belief on information provided by third parties, and makes no representation or warranty as to the accuracy of such information. Efforts are underway to better integrate information from third parties. TI has taken and continues to take reasonable steps to provide representative and accurate information but may not have conducted destructive testing or chemical analysis on incoming materials and chemicals. TI and TI suppliers consider certain information to be proprietary, and thus CAS numbers and other limited information may not be available for release.

In no event shall TI's liability arising out of such information exceed the total purchase price of the TI part(s) at issue in this document sold by TI to Customer on an annual basis.

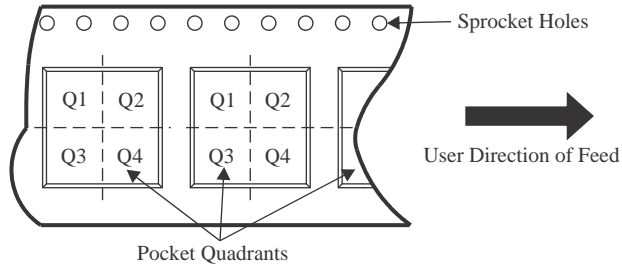

**TAPE AND REEL INFORMATION**

**QUADRANT ASSIGNMENTS FOR PIN 1 ORIENTATION IN TAPE**

\*All dimensions are nominal

Device	Package Type	Package Drawing	Pins	SPQ	Reel Diameter (mm)	Reel Width W1 (mm)	A0 (mm)	B0 (mm)	K0 (mm)	P1 (mm)	W (mm)	Pin1 Quadrant
TS3A225ERTER	WQFN	RTE	16	3000	330.0	12.4	3.3	3.3	1.1	8.0	12.0	Q2
TS3A225EYFFR	DSBGA	YFF	16	3000	180.0	8.4	1.65	1.65	0.81	4.0	8.0	Q1

**TAPE AND REEL BOX DIMENSIONS**

\*All dimensions are nominal

Device	Package Type	Package Drawing	Pins	SPQ	Length (mm)	Width (mm)	Height (mm)
TS3A225ERTER	WQFN	RTE	16	3000	346.0	346.0	33.0
TS3A225EYFFR	DSBGA	YFF	16	3000	182.0	182.0	20.0

## GENERIC PACKAGE VIEW

**RTE 16**

**WQFN - 0.8 mm max height**

3 x 3, 0.5 mm pitch

PLASTIC QUAD FLATPACK - NO LEAD

This image is a representation of the package family, actual package may vary.  
Refer to the product data sheet for package details.

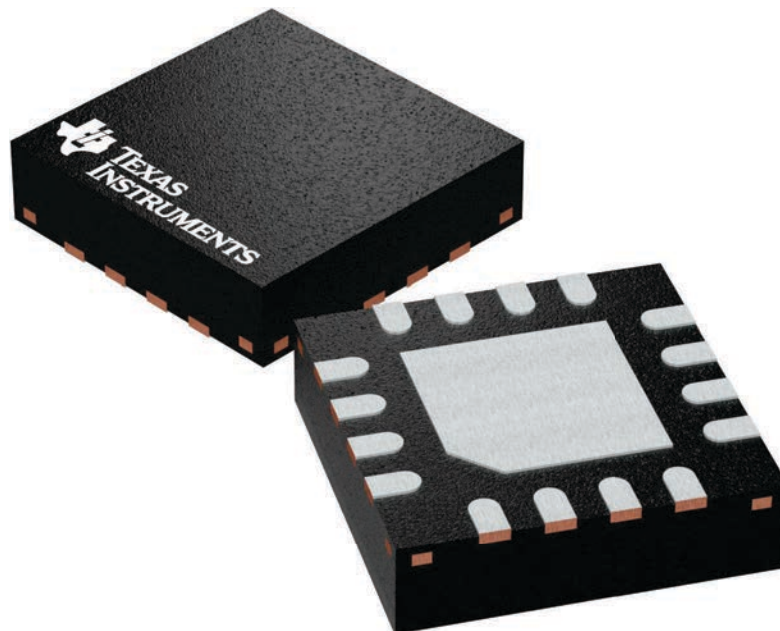

4225944/A

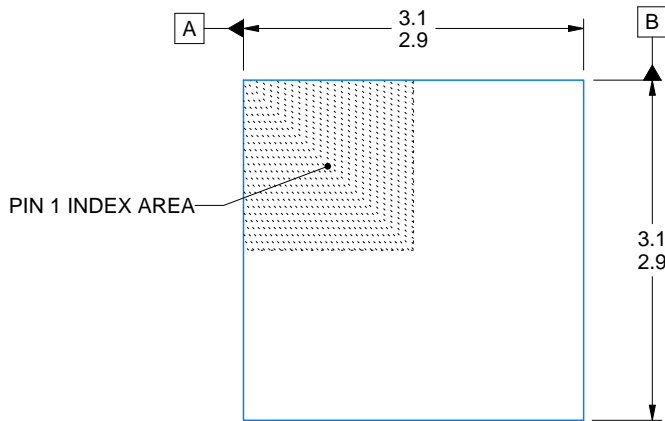

SIDE WALL METAL THICKNESS DIM A	
OPTION 1	OPTION 2
0.1	0.2

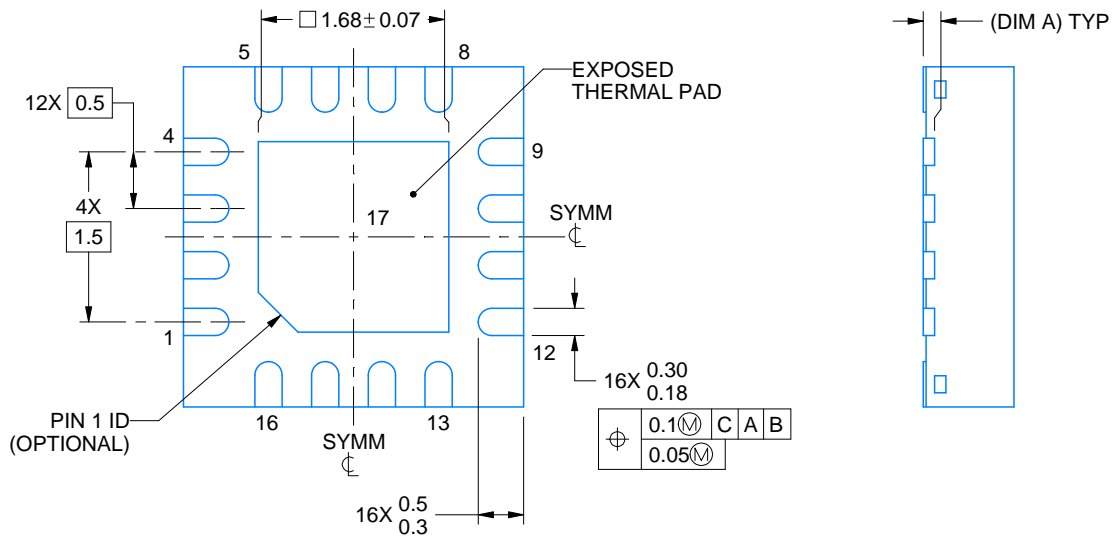
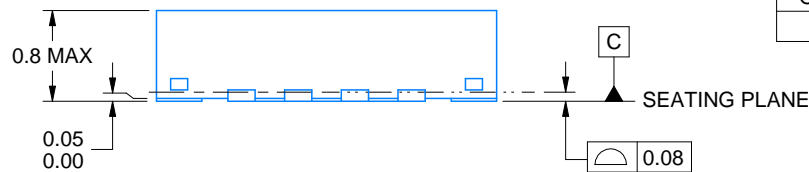

4219117/B 04/2022

NOTES:

1. All linear dimensions are in millimeters. Any dimensions in parenthesis are for reference only. Dimensioning and tolerancing per ASME Y14.5M.
2. This drawing is subject to change without notice.
3. The package thermal pad must be soldered to the printed circuit board for thermal and mechanical performance.



# EXAMPLE STENCIL DESIGN

RTE0016C

WQFN - 0.8 mm max height

PLASTIC QUAD FLATPACK - NO LEAD

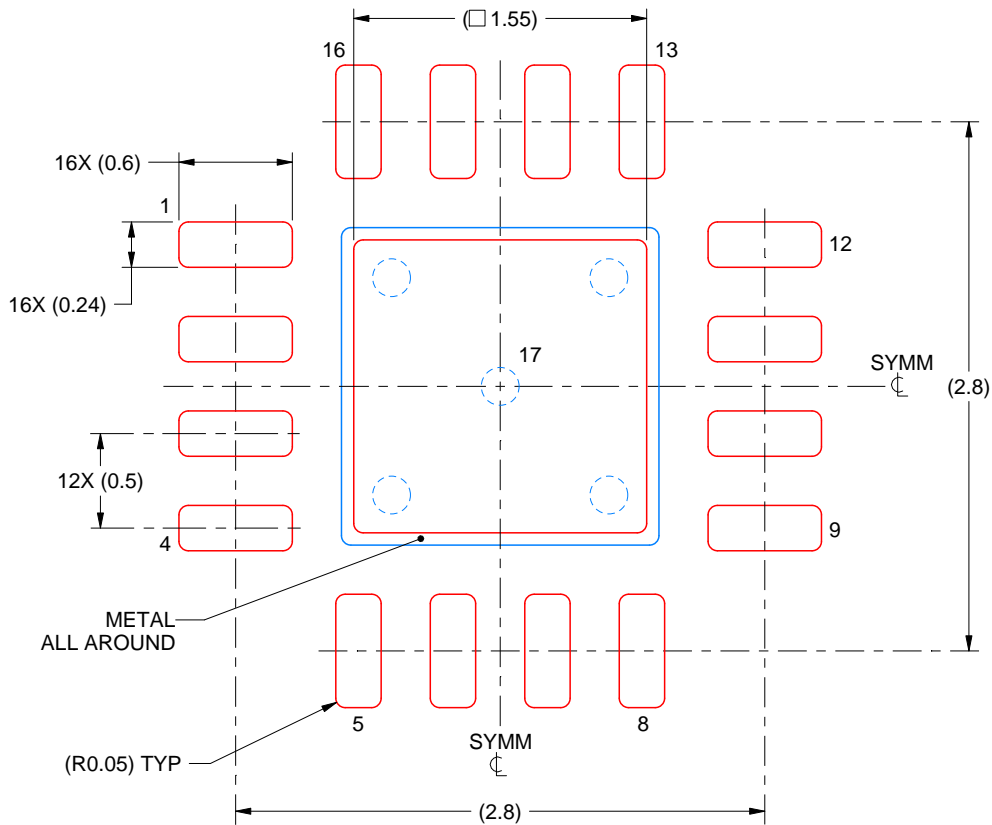

**SOLDER PASTE EXAMPLE**  
BASED ON 0.125 mm THICK STENCIL

EXPOSED PAD 17:  
85% PRINTED SOLDER COVERAGE BY AREA UNDER PACKAGE  
SCALE:25X

4219117/B 04/2022

NOTES: (continued)

6. Laser cutting apertures with trapezoidal walls and rounded corners may offer better paste release. IPC-7525 may have alternate design recommendations.

YFF0016

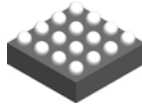

# PACKAGE OUTLINE

DSBGA - 0.625 mm max height

DIE SIZE BALL GRID ARRAY

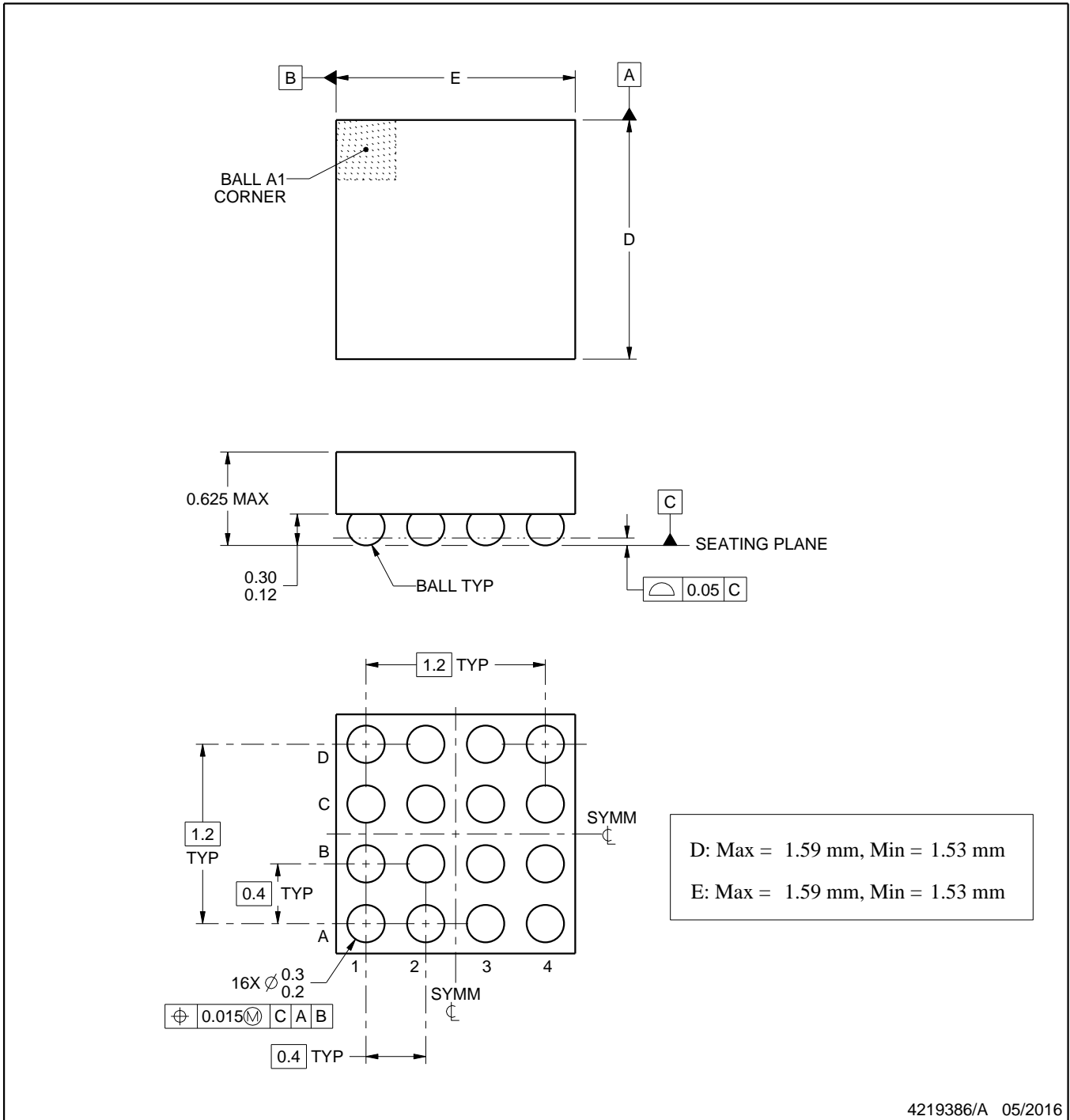

NOTES:

1. All linear dimensions are in millimeters. Any dimensions in parenthesis are for reference only. Dimensioning and tolerancing per ASME Y14.5M.
2. This drawing is subject to change without notice.

# EXAMPLE BOARD LAYOUT

YFF0016

DSBGA - 0.625 mm max height

DIE SIZE BALL GRID ARRAY

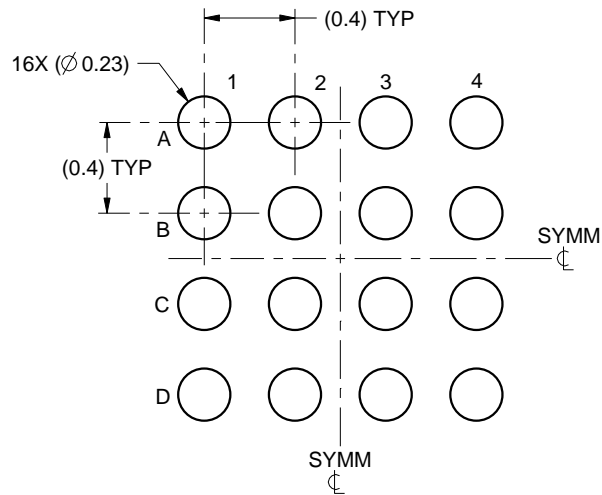

LAND PATTERN EXAMPLE  
SCALE:30X

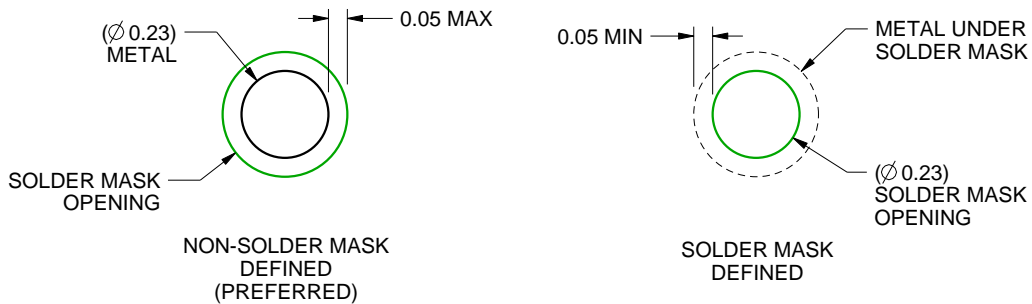

SOLDER MASK DETAILS  
NOT TO SCALE

4219386/A 05/2016

NOTES: (continued)

3. Final dimensions may vary due to manufacturing tolerance considerations and also routing constraints. For more information, see Texas Instruments literature number SNVA009 ([www.ti.com/lit/snva009](http://www.ti.com/lit/snva009)).

# EXAMPLE STENCIL DESIGN

YFF0016

DSBGA - 0.625 mm max height

DIE SIZE BALL GRID ARRAY

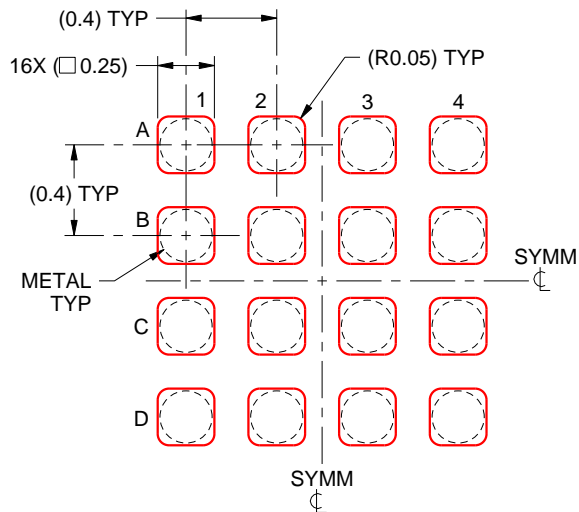

SOLDER PASTE EXAMPLE  
BASED ON 0.1 mm THICK STENCIL  
SCALE:30X

4219386/A 05/2016

NOTES: (continued)

4. Laser cutting apertures with trapezoidal walls and rounded corners may offer better paste release.

## IMPORTANT NOTICE AND DISCLAIMER

TI PROVIDES TECHNICAL AND RELIABILITY DATA (INCLUDING DATA SHEETS), DESIGN RESOURCES (INCLUDING REFERENCE DESIGNS), APPLICATION OR OTHER DESIGN ADVICE, WEB TOOLS, SAFETY INFORMATION, AND OTHER RESOURCES "AS IS" AND WITH ALL FAULTS, AND DISCLAIMS ALL WARRANTIES, EXPRESS AND IMPLIED, INCLUDING WITHOUT LIMITATION ANY IMPLIED WARRANTIES OF MERCHANTABILITY, FITNESS FOR A PARTICULAR PURPOSE OR NON-INFRINGEMENT OF THIRD PARTY INTELLECTUAL PROPERTY RIGHTS.

These resources are intended for skilled developers designing with TI products. You are solely responsible for (1) selecting the appropriate TI products for your application, (2) designing, validating and testing your application, and (3) ensuring your application meets applicable standards, and any other safety, security, regulatory or other requirements.

These resources are subject to change without notice. TI grants you permission to use these resources only for development of an application that uses the TI products described in the resource. Other reproduction and display of these resources is prohibited. No license is granted to any other TI intellectual property right or to any third party intellectual property right. TI disclaims responsibility for, and you will fully indemnify TI and its representatives against, any claims, damages, costs, losses, and liabilities arising out of your use of these resources.

TI's products are provided subject to [TI's Terms of Sale](#) or other applicable terms available either on [ti.com](https://www.ti.com) or provided in conjunction with such TI products. TI's provision of these resources does not expand or otherwise alter TI's applicable warranties or warranty disclaimers for TI products.

TI objects to and rejects any additional or different terms you may have proposed.

Mailing Address: Texas Instruments, Post Office Box 655303, Dallas, Texas 75265  
Copyright © 2024, Texas Instruments Incorporated

## Looking for pricing, stock, or lifecycle information?

Click below to explore more details on WIN SOURCE:

 [View TS3A225ERTER](#) on WIN SOURCE

 [Texas Instruments](#) Information

## Optimize Your Supply Chain with WIN SOURCE Solutions

-  Global Sourcing Solution
-  Obsolete Management
-  Cost Control Management
-  Shortage Management
-  Alternative Solution
-  Excess Inventory Management