



**THE DATASHEET OF  
TRSF3232ECDR**



# TRSF3232E 3-V TO 5.5-V Two-Channel RS-232 1-Mbit/s Line Driver and Receiver with $\pm 15$ -kV IEC ESD Protection in Small Package

## 1 Features

- Operates with 3-V to 5.5-V  $V_{CC}$  supply
- Operates up to 1 Mbit/s
- Low supply current: 300  $\mu$ A typical
- External capacitors:  $4 \times 0.1 \mu$ F
- Accept 5-V logic input with 3.3-V supply
- Latch-up performance exceeds 100 mA Per JESD 78, class II
- ESD protection for RS-232 pins
  - $\pm 15$ -kV Human-Body Model (HBM)
  - $\pm 15$ -kV IEC 61000-4-2 air-gap discharge
  - $\pm 8$ -kV IEC 61000-4-2 contact discharge
- Available in near chip scale QFN (3mmx3mm) package (85% smaller than SOIC-16)

## 2 Applications

- Industrial PCs
- Wired networking
- Data center and enterprise computing
- Battery-powered systems
- PDA's
- Notebooks
- Palmtop PCs
- Hand-held equipment

## 3 Description

The TRSF3232E consists of two line drivers, two line receivers, and a dual charge-pump circuit with  $\pm 15$ -kV ESD protection pin to pin (serial-port connection pins, including GND). This device provides the electrical interface between an asynchronous communication controller and the serial-port connector. The charge pump and four small external capacitors allow operation from a single 3-V to 5.5-V supply. The TRSF3232E operates at data signaling rates up to 1 Mbit/s and a driver output slew rate of 14 V/ $\mu$ s to 150 V/ $\mu$ s.

### Device Information

PART NUMBER	PACKAGE <sup>(1)</sup>	BODY SIZE (NOM)
TRSF3232E	D (SOIC)	9.90 mm x 3.91 mm
	DB (SSOP)	6.20 mm x 5.30 mm
	DW (SOIC)	10.3 mm x 7.50 mm
	PW (TSSOP)	5.00 mm x 4.40 mm
	RGT (VQFN)	3.00 mm x 3.00 mm

(1) For all available packages, see the orderable addendum at the end of the data sheet.

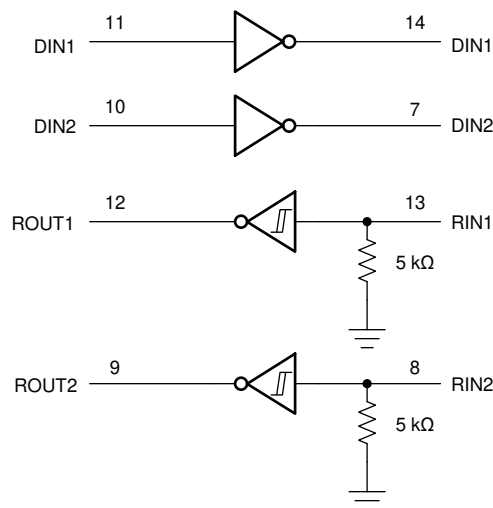

Logic Diagram (Positive Logic)



## Table of Contents

<b>1 Features</b> .....	1	8.1 Overview.....	10
<b>2 Applications</b> .....	1	8.2 Functional Block Diagram.....	10
<b>3 Description</b> .....	1	8.3 Feature Description.....	10
<b>4 Revision History</b> .....	2	8.4 Device Functional Modes.....	11
<b>5 Pin Configuration and Functions</b> .....	3	<b>9 Application and Implementation</b> .....	12
<b>6 Specifications</b> .....	4	9.1 Application Information.....	12
6.1 Absolute Maximum Ratings.....	4	9.2 Typical Application.....	12
6.2 ESD Ratings.....	4	<b>10 Power Supply Recommendations</b> .....	14
6.3 ESD Protection, Driver.....	4	<b>11 Layout</b> .....	14
6.4 ESD Protection, Receiver.....	4	11.1 Layout Guidelines.....	14
6.5 Recommended Operating Conditions.....	5	11.2 Layout Example.....	14
6.6 Thermal Information.....	5	<b>12 Device and Documentation Support</b> .....	15
6.7 Electrical Characteristics.....	5	12.1 Receiving Notification of Documentation Updates..	15
6.8 Electrical Characteristics, Driver.....	6	12.2 Support Resources.....	15
6.9 Electrical Characteristics, Receiver.....	6	12.3 Trademarks.....	15
6.10 Switching Characteristics, Driver.....	7	12.4 Electrostatic Discharge Caution.....	15
6.11 Switching Characteristics, Receiver.....	7	12.5 Glossary.....	15
6.12 Typical Characteristics.....	8	<b>13 Mechanical, Packaging, and Orderable Information</b> .....	15
<b>7 Parameter Measurement Information</b> .....	9		
<b>8 Detailed Description</b> .....	10		

## 4 Revision History

NOTE: Page numbers for previous revisions may differ from page numbers in the current version.

<b>Changes from Revision A (December 2020) to Revision B (June 2021)</b>	<b>Page</b>
• Added <i>Applications</i> : Industrial PCs, Wired networking, and Data center and enterprise computing.....	1
• Changed the table note in the <i>ESD Protection, Driver</i> table to make it applicable to D and PW packages.....	4
• Changed the table note in the <i>ESD Protection, Receiver</i> table to make it applicable to D and PW packages....	4
• Changed the thermal parameter values for D and PW packages in the <i>Thermal Information</i> table.....	5
<b>Changes from Revision * (August 2007) to Revision A (December 2020)</b>	<b>Page</b>
• Added Device Information table, ESD Ratings table, Feature Description section, Device Functional Modes, Application and Implementation section, Power Supply Recommendations section, Layout section, Device and Documentation Support section, and Mechanical, Packaging, and Orderable Information section.....	1
• Added Note to the <i>ESD Protection, Driver</i> .....	4
• Added Note to the <i>ESD Protection, Receiver</i> .....	4
• Added $t_{sk(p)}$ row for RGT package in the <i>Switching Characteristics, Driver</i> .....	7
• Added $t_{PLH}$ and $t_{PHL}$ rows for RGT package in the <i>Switching Characteristics, Receiver</i> .....	7
• Added $t_{sk(p)}$ row for RGT package in the <i>Switching Characteristics, Receiver</i> .....	7

## 5 Pin Configuration and Functions

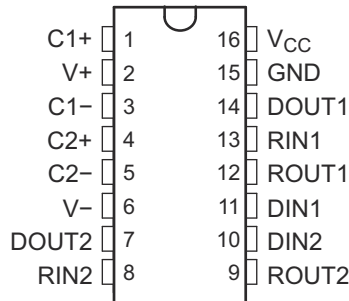

Figure 5-1. D, DB, DW, or PW Package (Top View)

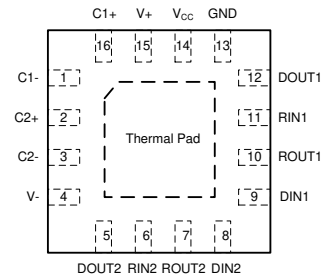

Figure 5-2. RGT, VQFN Package (Top View)

Table 5-1. Pin Functions

NAME	PIN		I/O <sup>(1)</sup>	DESCRIPTION
	D, DB, DW or PW	RGT		
C1+	1	16	-	Positive lead of C1 capacitor
V+	2	15	O	Positive charge pump output for storage capacitor only
C1-	3	1	-	Negative lead of C1 capacitor
C2+	4	2	-	Positive lead of C2 capacitor
C2-	5	3	-	Negative lead of C2 capacitor
V-	6	4	O	Negative charge pump output for storage capacitor only
DOUT2	7	5	O	RS232 line data output (to remote RS232 system)
RIN2	8	6	I	RS232 line data input (from remote RS232 system)
ROUT2	9	7	O	Logic data output (to UART)
DIN2	10	8	I	Logic data input (from UART)
DIN1	11	9	I	Logic data input (from UART)
ROUT1	12	10	O	Logic data output (to UART)
RIN1	13	11	I	RS232 line data input (from remote RS232 system)
DOUT1	14	12	O	RS232 line data output (to remote RS232 system)
GRD	15	13	-	Ground
V <sub>CC</sub>	16	14	-	Supply Voltage, Connect to external 3-V to 5.5-V power supply
Thermal Pad	-	Thermal Pad	-	Exposed thermal pad. Can be connected to GND or left floating.

(1) Signal Types: I = Input, O = Output, I/O = Input or Output.

## 6 Specifications

### 6.1 Absolute Maximum Ratings

over operating free-air temperature range (unless otherwise noted) see note <sup>(1)</sup>

		MIN	MAX	UNIT	
V <sub>CC</sub>	Supply voltage range <sup>(2)</sup>	-0.3	6	V	
V+	Positive-output supply voltage range <sup>(2)</sup>	-0.3	7	V	
V-	Negative-output supply voltage range <sup>(2)</sup>	0.3	-7	V	
V+ – V-	Supply voltage difference <sup>(2)</sup>		13	V	
V <sub>I</sub>	Input voltage range	Drivers	-0.3	6	V
		Receivers	-25	25	
V <sub>O</sub>	Output voltage range	Drivers	-13.2	13.2	V
		Receivers	-0.3	V <sub>CC</sub> + 0.3	
T <sub>J</sub>	Operating virtual junction temperature		150	°C	
T <sub>stg</sub>	Storage temperature range	-65	150	°C	

- (1) Stresses beyond those listed under "absolute maximum ratings" may cause permanent damage to the device. These are stress ratings only, and functional operation of the device at these or any other conditions beyond those indicated under "recommended operating conditions" is not implied. Exposure to absolute-maximum-rated conditions for extended periods may affect device reliability.
- (2) All voltages are with respect to network GND.

### 6.2 ESD Ratings

		VALUE	UNIT	
V <sub>(ESD)</sub>	Electrostatic discharge	Human-body model (HBM), per ANSI/ESDA/JEDEC JS-001 <sup>1</sup> .	±3000	V
		Charged-device model (CDM), per JEDEC specification JESD22-C101 <sup>2</sup>	±1500	

### 6.3 ESD Protection, Driver

PIN NAME	TEST CONDITIONS	TYP	UNIT
DOUT1, DOUT2	Human-body model (HBM)	±15	kV
	IEC 61000-4-2 Air-Gap Discharge <sup>(1)</sup>	±15	
	IEC 61000-4-2 Contact Discharge <sup>(1)</sup>	±8	

- (1) For RGT, D and PW packages only: A minimum of 1-μF capacitor is needed between V<sub>CC</sub> and GND to meet the specified IEC ESD level.

### 6.4 ESD Protection, Receiver

PIN NAME	TEST CONDITIONS	TYP	UNIT
RIN1, RIN2	HBM	±15	kV
	IEC 61000-4-2 Air-Gap Discharge <sup>(1)</sup>	±15	
	IEC 61000-4-2 Contact Discharge <sup>(1)</sup>	±8	

- (1) For RGT, D and PW packages only: A minimum of 1-μF capacitor is needed between V<sub>CC</sub> and GND to meet the specified IEC ESD level.

## 6.5 Recommended Operating Conditions

See note (1)

			MIN	NOM	MAX	UNIT
Supply voltage		$V_{CC} = 3.3\text{ V}$	3	3.3	3.6	V
		$V_{CC} = 5\text{ V}$	4.5	5	5.5	
$V_{IH}$ Driver high-level input voltage	DIN	$V_{CC} = 3.3\text{ V}$	2			V
		$V_{CC} = 5\text{ V}$	2.4			
$V_{IL}$ Driver low-level input voltage		DIN			0.8	V
$V_I$	Driver input voltage	DIN	0		5.5	V
	Receiver input voltage		-25		25	
$T_A$ Operating free-air temperature		TRSF3232EI	-40		85	°C
		TRSF3232EC	0		70	

(1) Test conditions are C1–C4 = 0.1  $\mu\text{F}$  at  $V_{CC} = 3.3\text{ V} \pm 0.3\text{ V}$ ; C1 = 0.047  $\mu\text{F}$ , C2–C4 = 0.33  $\mu\text{F}$  at  $V_{CC} = 5\text{ V} \pm 0.5\text{ V}$  (see Figure 9-1).

## 6.6 Thermal Information

THERMAL METRIC <sup>(1)</sup>		TRSF3232E					UNIT
		PW (TSSOP)	D (SOIC)	DW (SOIC)	DB (SSOP)	RGT (VQFN)	
		16 Pins	16 Pins	16 Pins	16 Pins	16 Pins	
$R_{\theta JA}$	Junction-to-ambient thermal resistance	108.2	85.9	57	46	48.8	°C/W
$R_{\theta JC(top)}$	Junction-to-case (bottom) thermal resistance	39.0	43.1	33.5	36.2	55.8	°C/W
$R_{\theta JB}$	Junction-to-board thermal resistance	54.4	44.5	37.1	43.8	23.2	°C/W
$\psi_{JT}$	Junction-to-top characterization parameter	3.3	10.1	7.5	4.2	1.7	°C/W
$\psi_{JB}$	Junction-to-board characterization parameter	53.8	44.1	37.1	42.9	23.2	°C/W
$R_{\theta JC(bot)}$	Junction-to-case (bottom) thermal resistance	N/A	N/A	N/A	N/A	9.0	°C/W

(1) For more information about traditional and new thermal metrics, see the [Semiconductor and IC package thermal metrics](#) application report.

## 6.7 Electrical Characteristics

over recommended ranges of supply voltage and operating free-air temperature (unless otherwise noted)

PARAMETER	TEST CONDITIONS <sup>(1)</sup>	MIN	TYP <sup>(2)</sup>	MAX	UNIT
$I_{CC}$ Supply current	No load, $V_{CC} = 3.3\text{ V}$ or $5\text{ V}$		0.3	1	mA

(1) Test conditions are C1–C4 = 0.1  $\mu\text{F}$  at  $V_{CC} = 3.3\text{ V} \pm 0.3\text{ V}$ ; C1 = 0.047  $\mu\text{F}$ , C2–C4 = 0.33  $\mu\text{F}$  at  $V_{CC} = 5\text{ V} \pm 0.5\text{ V}$  (see Figure 9-1).

(2) All typical values are at  $V_{CC} = 3.3\text{ V}$  or  $V_{CC} = 5\text{ V}$ , and  $T_A = 25^\circ\text{C}$ .

## 6.8 Electrical Characteristics, Driver

over recommended ranges of supply voltage and operating free-air temperature (unless otherwise noted)

PARAMETER	TEST CONDITIONS <sup>(1)</sup>		MIN	TYP <sup>(2)</sup>	MAX	UNIT
V <sub>OH</sub> High-level output voltage	DOUT at R <sub>L</sub> = 3 kΩ to GND,	DIN = GND	5	5.5		V
V <sub>OL</sub> Low-level output voltage	DOUT at R <sub>L</sub> = 3 kΩ to GND,	DIN = V <sub>CC</sub>	–5	–5.4		V
I <sub>IH</sub> High-level input current	V <sub>I</sub> = V <sub>CC</sub>			±0.01	±1	μA
I <sub>IL</sub> Low-level input current	V <sub>I</sub> at GND			±0.01	±1	μA
I <sub>OS</sub> <sup>(3)</sup> Short-circuit output current	V <sub>CC</sub> = 3.6 V, V <sub>O</sub> = 0 V			±35	±60	mA
	V <sub>CC</sub> = 5.5 V, V <sub>O</sub> = 0 V	RGT package only		±35	±60	
		D, DB, DW, PW packages		±35	±90	
r <sub>o</sub> Output resistance	V <sub>CC</sub> , V+, and V– = 0 V,	V <sub>O</sub> = ±2 V	300	10M		Ω

(1) Test conditions are C1–C4 = 0.1 μF at V<sub>CC</sub> = 3.3 V ± 0.3 V; C1 = 0.047 μF, C2–C4 = 0.33 μF at V<sub>CC</sub> = 5 V ± 0.5 V (see Figure 9-1).

(2) All typical values are at V<sub>CC</sub> = 3.3 V or V<sub>CC</sub> = 5 V, and T<sub>A</sub> = 25°C.

(3) Short-circuit durations should be controlled to prevent exceeding the device absolute power dissipation ratings, and not more than one output should be shorted at a time.

## 6.9 Electrical Characteristics, Receiver

over recommended ranges of supply voltage and operating free-air temperature (unless otherwise noted)

PARAMETER	TEST CONDITIONS <sup>(1)</sup>		MIN	TYP <sup>(2)</sup>	MAX	UNIT
V <sub>OH</sub> High-level output voltage	I <sub>OH</sub> = –1 mA		V <sub>CC</sub> – 0.6	V <sub>CC</sub> – 0.1		V
V <sub>OL</sub> Low-level output voltage	I <sub>OL</sub> = 1.6 mA				0.4	V
V <sub>IT+</sub> Positive-going input threshold voltage	V <sub>CC</sub> = 3.3 V			1.5	2.4	V
	V <sub>CC</sub> = 5 V			1.8	2.4	
V <sub>IT–</sub> Negative-going input threshold voltage	V <sub>CC</sub> = 3.3 V		0.6	1.2		V
	V <sub>CC</sub> = 5 V		0.8	1.5		
V <sub>hys</sub> Input hysteresis (V <sub>IT+</sub> – V <sub>IT–</sub> )				0.3		V
r <sub>i</sub> Input resistance	V <sub>I</sub> = ±3 V to ±25 V		3	5	7	kΩ

(1) Test conditions are C1–C4 = 0.1 μF at V<sub>CC</sub> = 3.3 V ± 0.3 V; C1 = 0.047 μF, C2–C4 = 0.33 μF at V<sub>CC</sub> = 5 V ± 0.5 V (see Figure 9-1).

(2) All typical values are at V<sub>CC</sub> = 3.3 V or V<sub>CC</sub> = 5 V, and T<sub>A</sub> = 25°C.

## 6.10 Switching Characteristics, Driver

over recommended ranges of supply voltage and operating free-air temperature (unless otherwise noted)

		TEST CONDITIONS <sup>(1)</sup>		MIN	TYP <sup>(2)</sup>	MAX	UNIT
Maximum data rate (see Figure 7-1)	R <sub>L</sub> = 3 kΩ, One DOUT switching	C <sub>L</sub> = 250 pF, V <sub>CC</sub> = 3 V to 4.5 V		1000			kbit/s
		C <sub>L</sub> = 1000 pF, V <sub>CC</sub> = 3.5 V to 5.5 V		1000			
t <sub>sk(p)</sub> Pulse skew <sup>(3)</sup>	C <sub>L</sub> = 1000 pF, R <sub>L</sub> = 3 kΩ, V <sub>CC</sub> = 5 V (see Figure 7-2)	RGT package only		70			ns
	C <sub>L</sub> = 150 pF to 2500 pF, R <sub>L</sub> = 3 kΩ to 7 kΩ (see Figure 7-2)	D, DB, DW, PW packages		300			
SR(tr) Slew rate, transition region (see Figure 7-1)	R <sub>L</sub> = 3 kΩ to 7 kΩ, C <sub>L</sub> = 150 pF to 1000 pF, V <sub>CC</sub> = 3.3 V			14		150	V/μs

(1) Test conditions are C<sub>1</sub>–C<sub>4</sub> = 0.1 μF at V<sub>CC</sub> = 3.3 V ± 0.3 V; C<sub>1</sub> = 0.047 μF, C<sub>2</sub>–C<sub>4</sub> = 0.33 μF at V<sub>CC</sub> = 5 V ± 0.5 V (see Figure 9-1).

(2) All typical values are at V<sub>CC</sub> = 3.3 V or V<sub>CC</sub> = 5 V, and T<sub>A</sub> = 25°C.

(3) Pulse skew is defined as |t<sub>PLH</sub> – t<sub>PHL</sub>| of each channel of the same device.

## 6.11 Switching Characteristics, Receiver

over recommended ranges of supply voltage and operating free-air temperature (unless otherwise noted)

		TEST CONDITIONS <sup>(1)</sup>		MIN	TYP <sup>(2)</sup>	MAX	UNIT
t <sub>PLH</sub> Propagation delay time, low- to high-level output	C <sub>L</sub> = 150 pF	RGT package		85			ns
		D, DB, DW, PW packages		300			
t <sub>PHL</sub> Propagation delay time, high- to low-level output	C <sub>L</sub> = 150 pF	RGT package		110			ns
		D, DB, DW, PW packages		300			
t <sub>sk(p)</sub> Pulse skew <sup>(3)</sup>	RGT package			25			ns
	D, DB, DW, PW packages			300			

(1) Test conditions are C<sub>1</sub>–C<sub>4</sub> = 0.1 μF at V<sub>CC</sub> = 3.3 V ± 0.3 V; C<sub>1</sub> = 0.047 μF, C<sub>2</sub>–C<sub>4</sub> = 0.33 μF at V<sub>CC</sub> = 5 V ± 0.5 V (see Figure 9-1).

(2) All typical values are at V<sub>CC</sub> = 3.3 V or V<sub>CC</sub> = 5 V, and T<sub>A</sub> = 25°C.

(3) Pulse skew is defined as |t<sub>PLH</sub> – t<sub>PHL</sub>| of each channel of the same device.

## 6.12 Typical Characteristics

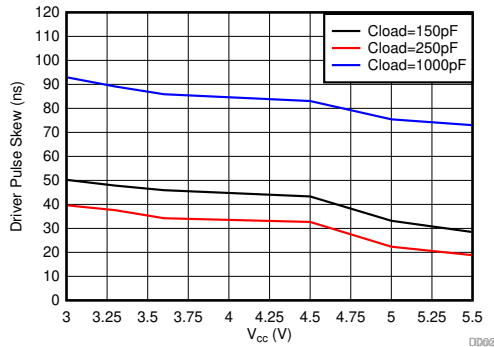

Figure 6-1. Driver pulse skew at T<sub>A</sub> = 25 °C (RGT package)

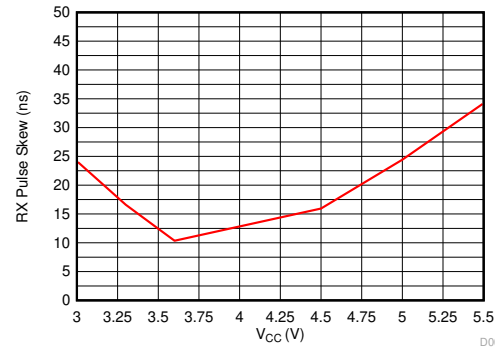

Figure 6-2. Receiver path skew at T<sub>A</sub> = 25 °C (t<sub>pHL</sub> - t<sub>pLH</sub>) (RGT package)

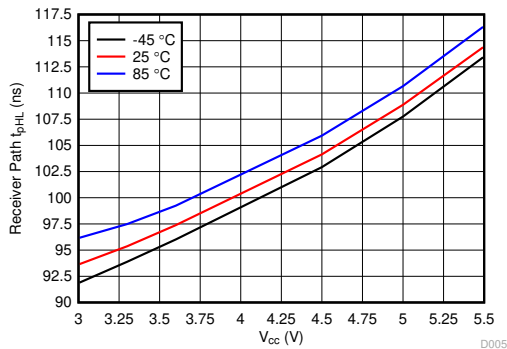

Figure 6-3. Receiver path high-to-low propagation delay, C<sub>L</sub> = 150 pF (RGT package)

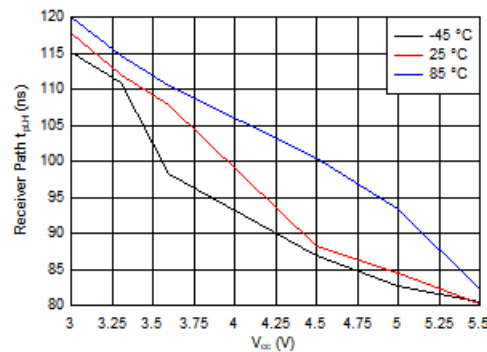
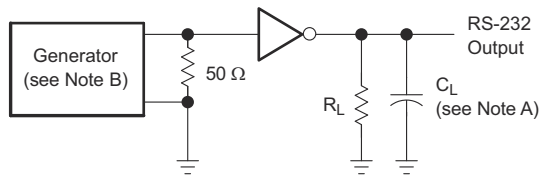

Figure 6-4. Receiver path low-to-high propagation delay, C<sub>L</sub> = 150 pF (RGT package)

## 7 Parameter Measurement Information



TEST CIRCUIT

$$SR(tr) = \frac{6\text{ V}}{t_{THL} \text{ or } t_{TLH}}$$

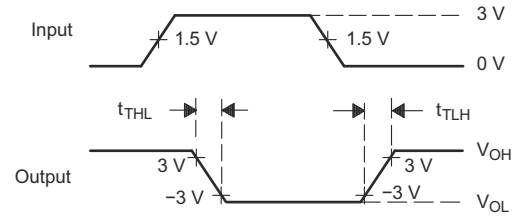

VOLTAGE WAVEFORMS

- NOTES: A. C<sub>L</sub> includes probe and jig capacitance.  
 B. The pulse generator has the following characteristics: PRR = 250 kbit/s, Z<sub>O</sub> = 50 Ω, 50% duty cycle, t<sub>r</sub> ≤ 10 ns, t<sub>f</sub> ≤ 10 ns.

**Figure 7-1. Driver Slew Rate**

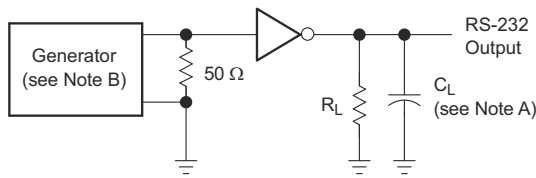

TEST CIRCUIT

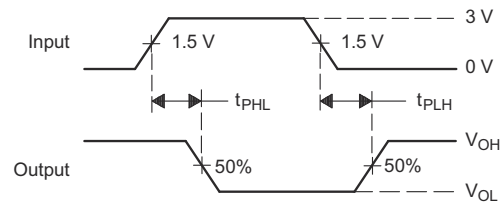

VOLTAGE WAVEFORMS

- NOTES: A. C<sub>L</sub> includes probe and jig capacitance.  
 B. The pulse generator has the following characteristics: PRR = 250 kbit/s, Z<sub>O</sub> = 50 Ω, 50% duty cycle, t<sub>r</sub> ≤ 10 ns, t<sub>f</sub> ≤ 10 ns.

**Figure 7-2. Driver Pulse Skew**

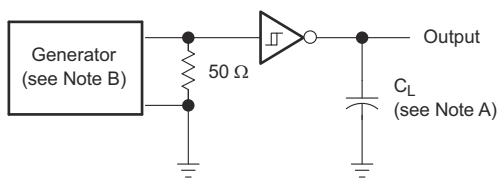

TEST CIRCUIT

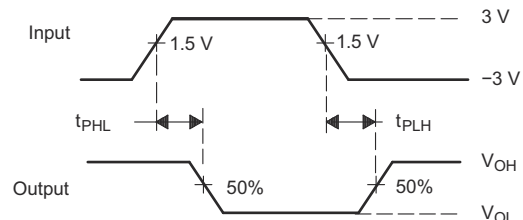

VOLTAGE WAVEFORMS

- NOTES: A. C<sub>L</sub> includes probe and jig capacitance.  
 B. The pulse generator has the following characteristics: Z<sub>O</sub> = 50 Ω, 50% duty cycle, t<sub>r</sub> ≤ 10 ns, t<sub>f</sub> ≤ 10 ns.

**Figure 7-3. Receiver Propagation Delay Times**

## 8 Detailed Description

### 8.1 Overview

The TRSF3232E device consists of two line drivers, two line receivers, and a dual charge-pump circuit with  $\pm 15$ -kV IEC ESD protection between serial-port connection terminals and GND. The device meets the requirements of TIA/EIA-232-F and provides the electrical interface between an asynchronous communication controller and the serial-port connector. The charge pump and four small external capacitors allow operation from one 3-V to 5.5-V supply. The device operates at data signaling rates up to 1 Mbps and a maximum of 150-V/ $\mu$ s driver output slew rate. Outputs are protected against shorts to ground.

### 8.2 Functional Block Diagram

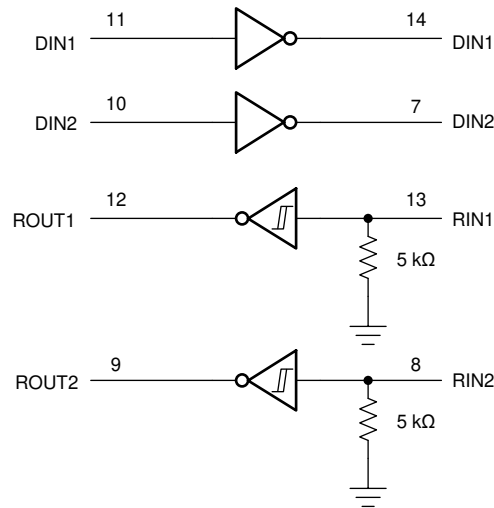

### 8.3 Feature Description

#### 8.3.1 Power

The power block increases, inverts, and regulates voltage at V+ and V– pins using a charge pump that requires four external capacitors.

#### 8.3.2 RS232 Driver

Two drivers interface the standard logic level to RS232 levels. Both DIN inputs must be valid high or low.

#### 8.3.3 RS232 Receiver

Two receivers interface RS232 levels to standard logic levels. An open input results in a high output on ROUT. Each RIN input includes an internal standard RS232 load.

## 8.4 Device Functional Modes

**Table 8-1. Each Driver**

INPUT DIN <sup>(1)</sup>	OUTPUT DOUT
L	H
H	L

(1) H = high level, L = low level

**Table 8-2. Each Receiver**

INPUT RIN <sup>(1)</sup>	OUTPUT ROUT
L	H
H	L
Open	H

(1) H = high level, L = low level,  
Open = input disconnected or connected driver off

### 8.4.1 V<sub>CC</sub> Powered by 3 V to 5.5 V

The device is in normal operation.

### 8.4.2 V<sub>CC</sub> Unpowered, V<sub>CC</sub> = 0 V

When the TRSF3232E device is unpowered, it can be safely connected to an active remote RS232 device.



### 9.2.1 Design Requirements

- Recommended  $V_{CC}$  is 3.3 V or 5 V
  - 3 V to 5.5 V is also possible
- Maximum recommended bit rate is 250 kbites

**Table 9-2.  $V_{CC}$  versus Capacitor Values**

$V_{CC}$	C1	C2, C3, C4
3.3 V $\pm$ 0.3 V	0.1 $\mu$ F	0.1 $\mu$ F
5 V $\pm$ 0.5 V	0.047 $\mu$ F	0.33 $\mu$ F
3 V to 5.5 V	0.1 $\mu$ F	0.47 $\mu$ F

### 9.2.2 Detailed Design Procedure

All DIN inputs must be connected to valid low or high logic levels. Select capacitor values based on  $V_{CC}$  level for best performance.

### 9.2.3 Application Performance Plots

$V_{CC}$  must be between 3 V and 5.5 V. Charge pump capacitors must be chosen using [Table 3](#)

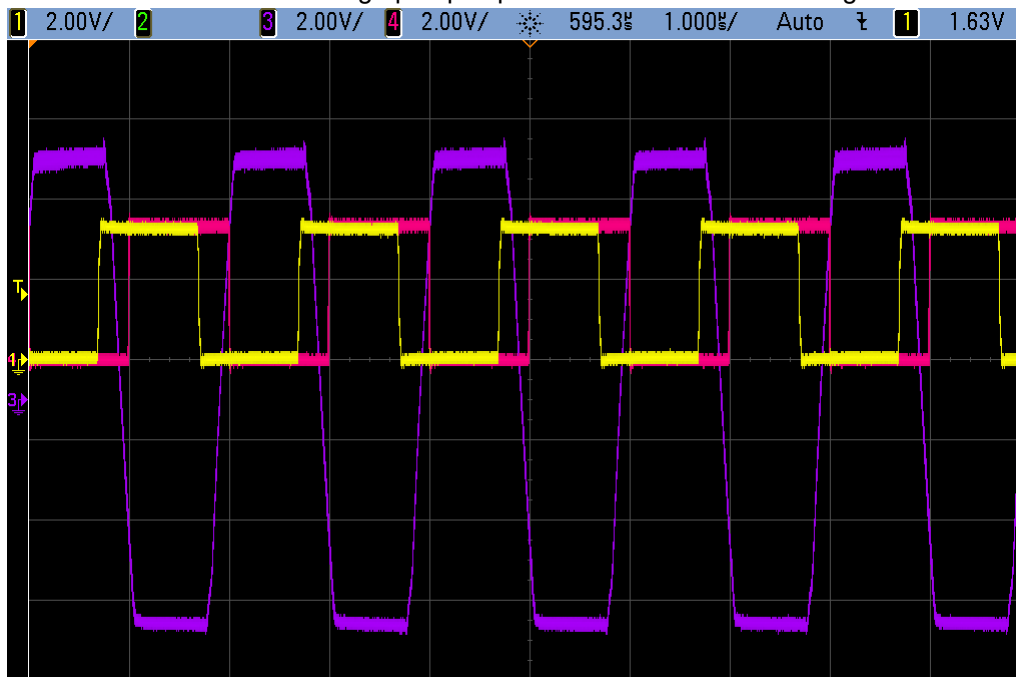

**Figure 9-2. 1 Mbps timing waveform from driver input to receiver output loopback. DOUT to RIN trace is in purple, DIN trace is in yellow and ROUT trace is in pink**

## 10 Power Supply Recommendations

The supply voltage,  $V_{CC}$ , should be between 3 V and 5.5 V. Select the charge-pump capacitors using [Table 3](#).

## 11 Layout

### 11.1 Layout Guidelines

Keep the external capacitor traces short, specifically on the C1 and C2 nodes that have the fastest rise and fall times.

### 11.2 Layout Example

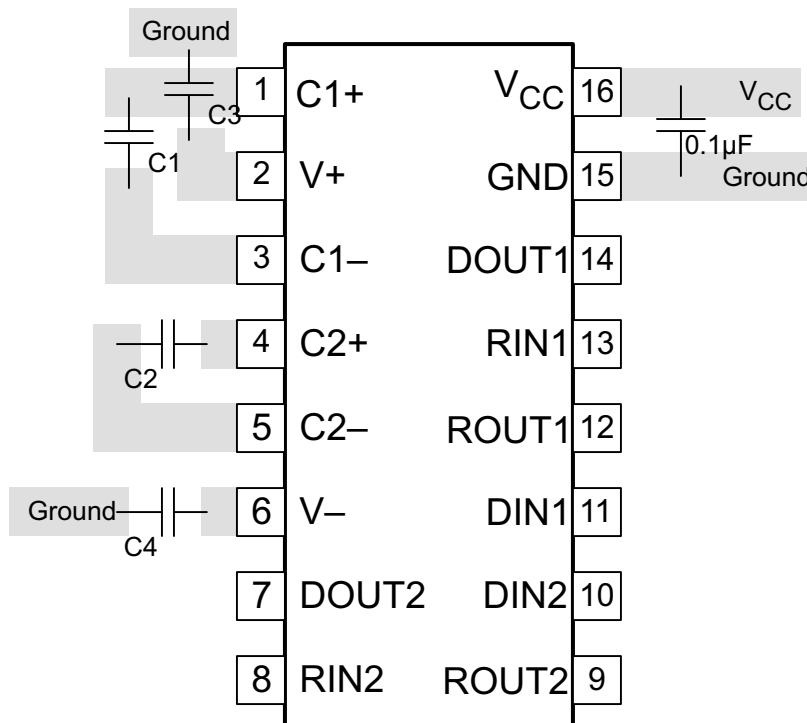

Figure 11-1. Layout Diagram

## 12 Device and Documentation Support

TI offers an extensive line of development tools. Tools and software to evaluate the performance of the device, generate code, and develop solutions are listed below.

### 12.1 Receiving Notification of Documentation Updates

To receive notification of documentation updates, navigate to the device product folder on [ti.com](http://ti.com). Click on *Subscribe to updates* to register and receive a weekly digest of any product information that has changed. For change details, review the revision history included in any revised document.

### 12.2 Support Resources

[TI E2E™ support forums](#) are an engineer's go-to source for fast, verified answers and design help — straight from the experts. Search existing answers or ask your own question to get the quick design help you need.

Linked content is provided "AS IS" by the respective contributors. They do not constitute TI specifications and do not necessarily reflect TI's views; see TI's [Terms of Use](#).

### 12.3 Trademarks

TI E2E™ is a trademark of Texas Instruments.  
All trademarks are the property of their respective owners.

### 12.4 Electrostatic Discharge Caution



This integrated circuit can be damaged by ESD. Texas Instruments recommends that all integrated circuits be handled with appropriate precautions. Failure to observe proper handling and installation procedures can cause damage.

ESD damage can range from subtle performance degradation to complete device failure. Precision integrated circuits may be more susceptible to damage because very small parametric changes could cause the device not to meet its published specifications.

### 12.5 Glossary

[TI Glossary](#) This glossary lists and explains terms, acronyms, and definitions.

## 13 Mechanical, Packaging, and Orderable Information

The following pages include mechanical, packaging, and orderable information. This information is the most current data available for the designated devices. This data is subject to change without notice and revision of this document. For browser-based versions of this data sheet, refer to the left-hand navigation.

**PACKAGING INFORMATION**

Orderable Device	Status (1)	Package Type	Package Drawing	Pins	Package Qty	Eco Plan (2)	Lead finish/ Ball material (6)	MSL Peak Temp (3)	Op Temp (°C)	Device Marking (4/5)	Samples
TRSF3232ECDBR	ACTIVE	SSOP	DB	16	2000	RoHS & Green	NIPDAU	Level-1-260C-UNLIM	0 to 70	RT32EC	<a href="#">Samples</a>
TRSF3232ECDR	ACTIVE	SOIC	D	16	2500	RoHS & Green	NIPDAU	Level-1-260C-UNLIM	0 to 70	TRSF3232EC	<a href="#">Samples</a>
TRSF3232ECPWR	ACTIVE	TSSOP	PW	16	2000	RoHS & Green	NIPDAU	Level-1-260C-UNLIM	0 to 70	RT32EC	<a href="#">Samples</a>
TRSF3232EIDBR	ACTIVE	SSOP	DB	16	2000	RoHS & Green	NIPDAU	Level-1-260C-UNLIM	-40 to 85	RT32EI	<a href="#">Samples</a>
TRSF3232EIDR	ACTIVE	SOIC	D	16	2500	RoHS & Green	NIPDAU	Level-1-260C-UNLIM	-40 to 85	TRSF3232EI	<a href="#">Samples</a>
TRSF3232EIDW	ACTIVE	SOIC	DW	16	40	RoHS & Green	NIPDAU	Level-1-260C-UNLIM	-40 to 85	TRSF3232EI	<a href="#">Samples</a>
TRSF3232EIDWR	ACTIVE	SOIC	DW	16	2000	RoHS & Green	NIPDAU	Level-1-260C-UNLIM	-40 to 85	TRSF3232EI	<a href="#">Samples</a>
TRSF3232EIPWR	ACTIVE	TSSOP	PW	16	2000	RoHS & Green	NIPDAU	Level-1-260C-UNLIM	-40 to 85	RT32EI	<a href="#">Samples</a>
TRSF3232EIRGTR	ACTIVE	VQFN	RGT	16	3000	RoHS & Green	NIPDAU	Level-1-260C-UNLIM	-40 to 85	F3232	<a href="#">Samples</a>

(1) The marketing status values are defined as follows:

**ACTIVE:** Product device recommended for new designs.

**LIFEBUY:** TI has announced that the device will be discontinued, and a lifetime-buy period is in effect.

**NRND:** Not recommended for new designs. Device is in production to support existing customers, but TI does not recommend using this part in a new design.

**PREVIEW:** Device has been announced but is not in production. Samples may or may not be available.

**OBSELETE:** TI has discontinued the production of the device.

(2) **RoHS:** TI defines "RoHS" to mean semiconductor products that are compliant with the current EU RoHS requirements for all 10 RoHS substances, including the requirement that RoHS substance do not exceed 0.1% by weight in homogeneous materials. Where designed to be soldered at high temperatures, "RoHS" products are suitable for use in specified lead-free processes. TI may reference these types of products as "Pb-Free".

**RoHS Exempt:** TI defines "RoHS Exempt" to mean products that contain lead but are compliant with EU RoHS pursuant to a specific EU RoHS exemption.

**Green:** TI defines "Green" to mean the content of Chlorine (Cl) and Bromine (Br) based flame retardants meet JS709B low halogen requirements of <=1000ppm threshold. Antimony trioxide based flame retardants must also meet the <=1000ppm threshold requirement.

(3) MSL, Peak Temp. - The Moisture Sensitivity Level rating according to the JEDEC industry standard classifications, and peak solder temperature.

(4) There may be additional marking, which relates to the logo, the lot trace code information, or the environmental category on the device.

<sup>(5)</sup> Multiple Device Markings will be inside parentheses. Only one Device Marking contained in parentheses and separated by a "~" will appear on a device. If a line is indented then it is a continuation of the previous line and the two combined represent the entire Device Marking for that device.

<sup>(6)</sup> Lead finish/Ball material - Orderable Devices may have multiple material finish options. Finish options are separated by a vertical ruled line. Lead finish/Ball material values may wrap to two lines if the finish value exceeds the maximum column width.

**Important Information and Disclaimer:**The information provided on this page represents TI's knowledge and belief as of the date that it is provided. TI bases its knowledge and belief on information provided by third parties, and makes no representation or warranty as to the accuracy of such information. Efforts are underway to better integrate information from third parties. TI has taken and continues to take reasonable steps to provide representative and accurate information but may not have conducted destructive testing or chemical analysis on incoming materials and chemicals. TI and TI suppliers consider certain information to be proprietary, and thus CAS numbers and other limited information may not be available for release.

In no event shall TI's liability arising out of such information exceed the total purchase price of the TI part(s) at issue in this document sold by TI to Customer on an annual basis.

**TAPE AND REEL INFORMATION**

**QUADRANT ASSIGNMENTS FOR PIN 1 ORIENTATION IN TAPE**



\*All dimensions are nominal

Device	Package Type	Package Drawing	Pins	SPQ	Reel Diameter (mm)	Reel Width W1 (mm)	A0 (mm)	B0 (mm)	K0 (mm)	P1 (mm)	W (mm)	Pin1 Quadrant
TRSF3232ECDBR	SSOP	DB	16	2000	330.0	16.4	8.35	6.6	2.4	12.0	16.0	Q1
TRSF3232ECDR	SOIC	D	16	2500	330.0	16.4	6.5	10.3	2.1	8.0	16.0	Q1
TRSF3232ECDR	SOIC	D	16	2500	330.0	16.4	6.5	10.3	2.1	8.0	16.0	Q1
TRSF3232ECPWR	TSSOP	PW	16	2000	330.0	12.4	6.9	5.6	1.6	8.0	12.0	Q1
TRSF3232EIDBR	SSOP	DB	16	2000	330.0	16.4	8.35	6.6	2.4	12.0	16.0	Q1
TRSF3232EIDR	SOIC	D	16	2500	330.0	16.4	6.5	10.3	2.1	8.0	16.0	Q1
TRSF3232EIDR	SOIC	D	16	2500	330.0	16.4	6.5	10.3	2.1	8.0	16.0	Q1
TRSF3232EIDWR	SOIC	DW	16	2000	330.0	16.4	10.75	10.7	2.7	12.0	16.0	Q1
TRSF3232EIPWR	TSSOP	PW	16	2000	330.0	12.4	6.9	5.6	1.6	8.0	12.0	Q1
TRSF3232EIPWR	TSSOP	PW	16	2000	330.0	12.4	6.9	5.6	1.6	8.0	12.0	Q1
TRSF3232EIRGTR	VQFN	RGT	16	3000	330.0	12.4	3.3	3.3	1.1	8.0	12.0	Q2

**TAPE AND REEL BOX DIMENSIONS**

\*All dimensions are nominal

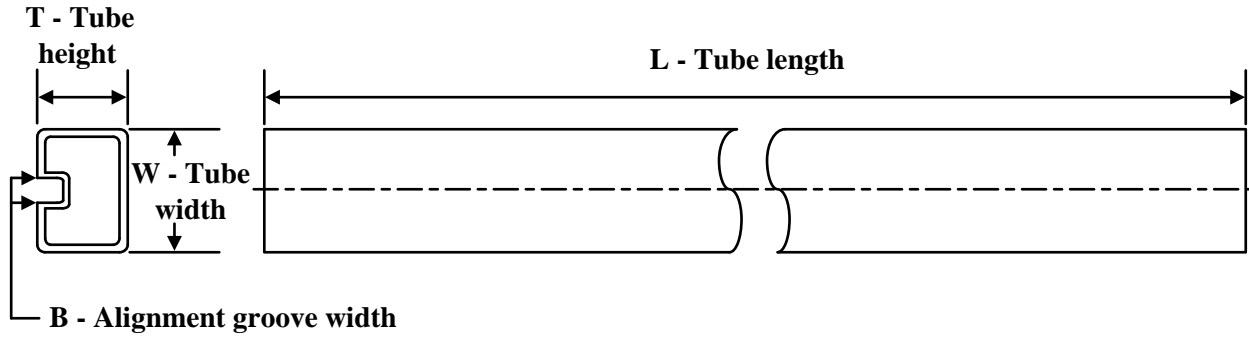
Device	Package Type	Package Drawing	Pins	SPQ	Length (mm)	Width (mm)	Height (mm)
TRSF3232ECDBR	SSOP	DB	16	2000	356.0	356.0	35.0
TRSF3232ECDR	SOIC	D	16	2500	356.0	356.0	35.0
TRSF3232ECDR	SOIC	D	16	2500	356.0	356.0	35.0
TRSF3232ECPWR	TSSOP	PW	16	2000	356.0	356.0	35.0
TRSF3232EIDBR	SSOP	DB	16	2000	356.0	356.0	35.0
TRSF3232EIDR	SOIC	D	16	2500	356.0	356.0	35.0
TRSF3232EIDR	SOIC	D	16	2500	356.0	356.0	35.0
TRSF3232EIDWR	SOIC	DW	16	2000	350.0	350.0	43.0
TRSF3232EIPWR	TSSOP	PW	16	2000	356.0	356.0	35.0
TRSF3232EIPWR	TSSOP	PW	16	2000	356.0	356.0	35.0
TRSF3232EIRGTR	VQFN	RGT	16	3000	367.0	367.0	35.0

**TUBE**

\*All dimensions are nominal

Device	Package Name	Package Type	Pins	SPQ	L (mm)	W (mm)	T (μm)	B (mm)
TRSF3232EIDW	DW	SOIC	16	40	506.98	12.7	4826	6.6

D (R-PDSO-G16)

PLASTIC SMALL OUTLINE



4040047-6/M 06/11

- NOTES:
- A. All linear dimensions are in inches (millimeters).
  - B. This drawing is subject to change without notice.
  - Body length does not include mold flash, protrusions, or gate burrs. Mold flash, protrusions, or gate burrs shall not exceed 0.006 (0,15) each side.
  - Body width does not include interlead flash. Interlead flash shall not exceed 0.017 (0,43) each side.
  - E. Reference JEDEC MS-012 variation AC.



NOTES:

1. All linear dimensions are in millimeters. Any dimensions in parenthesis are for reference only. Dimensioning and tolerancing per ASME Y14.5M.
2. This drawing is subject to change without notice.
3. This dimension does not include mold flash, protrusions, or gate burrs. Mold flash, protrusions, or gate burrs shall not exceed 0.15 mm per side.
4. This dimension does not include interlead flash. Interlead flash shall not exceed 0.25 mm per side.
5. Reference JEDEC registration MO-153.

# EXAMPLE BOARD LAYOUT

PW0016A

TSSOP - 1.2 mm max height

SMALL OUTLINE PACKAGE



LAND PATTERN EXAMPLE  
EXPOSED METAL SHOWN  
SCALE: 10X



SOLDER MASK DETAILS

4220204/A 02/2017

NOTES: (continued)

- 6. Publication IPC-7351 may have alternate designs.
- 7. Solder mask tolerances between and around signal pads can vary based on board fabrication site.

# EXAMPLE STENCIL DESIGN

PW0016A

TSSOP - 1.2 mm max height

SMALL OUTLINE PACKAGE



SOLDER PASTE EXAMPLE  
BASED ON 0.125 mm THICK STENCIL  
SCALE: 10X

4220204/A 02/2017

NOTES: (continued)

8. Laser cutting apertures with trapezoidal walls and rounded corners may offer better paste release. IPC-7525 may have alternate design recommendations.
9. Board assembly site may have different recommendations for stencil design.

# DB0016A



# PACKAGE OUTLINE

## SSOP - 2 mm max height

SMALL OUTLINE PACKAGE



4220763/A 05/2022

### NOTES:

1. All linear dimensions are in millimeters. Any dimensions in parenthesis are for reference only. Dimensioning and tolerancing per ASME Y14.5M.
2. This drawing is subject to change without notice.
3. This dimension does not include mold flash, protrusions, or gate burrs. Mold flash, protrusions, or gate burrs shall not exceed 0.15 mm per side.
4. Reference JEDEC registration MO-150.

# EXAMPLE BOARD LAYOUT

DB0016A

SSOP - 2 mm max height

SMALL OUTLINE PACKAGE



LAND PATTERN EXAMPLE  
EXPOSED METAL SHOWN  
SCALE: 10X



4220763/A 05/2022

NOTES: (continued)

- 5. Publication IPC-7351 may have alternate designs.
- 6. Solder mask tolerances between and around signal pads can vary based on board fabrication site.

# EXAMPLE STENCIL DESIGN

DB0016A

SSOP - 2 mm max height

SMALL OUTLINE PACKAGE



SOLDER PASTE EXAMPLE  
BASED ON 0.125 mm THICK STENCIL  
SCALE: 10X

4220763/A 05/2022

NOTES: (continued)

7. Laser cutting apertures with trapezoidal walls and rounded corners may offer better paste release. IPC-7525 may have alternate design recommendations.
8. Board assembly site may have different recommendations for stencil design.

## GENERIC PACKAGE VIEW

**DW 16**

**SOIC - 2.65 mm max height**

7.5 x 10.3, 1.27 mm pitch

SMALL OUTLINE INTEGRATED CIRCUIT

This image is a representation of the package family, actual package may vary.  
Refer to the product data sheet for package details.

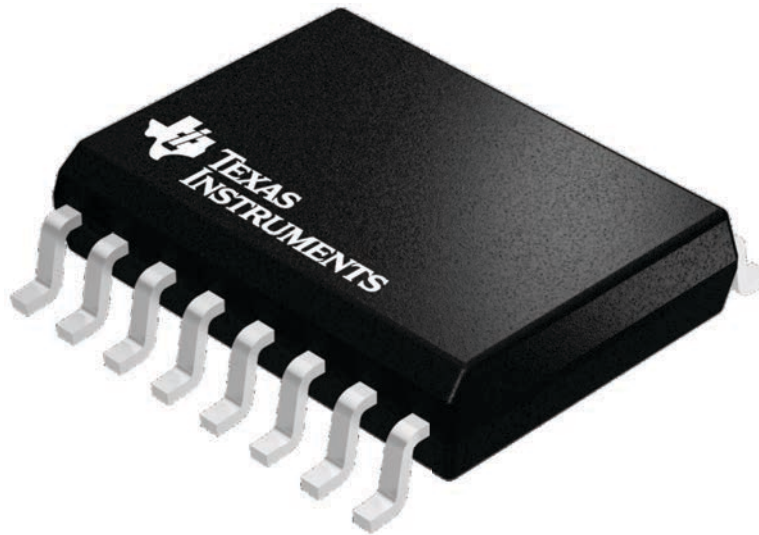

4224780/A



# DW0016A

# PACKAGE OUTLINE SOIC - 2.65 mm max height

SOIC

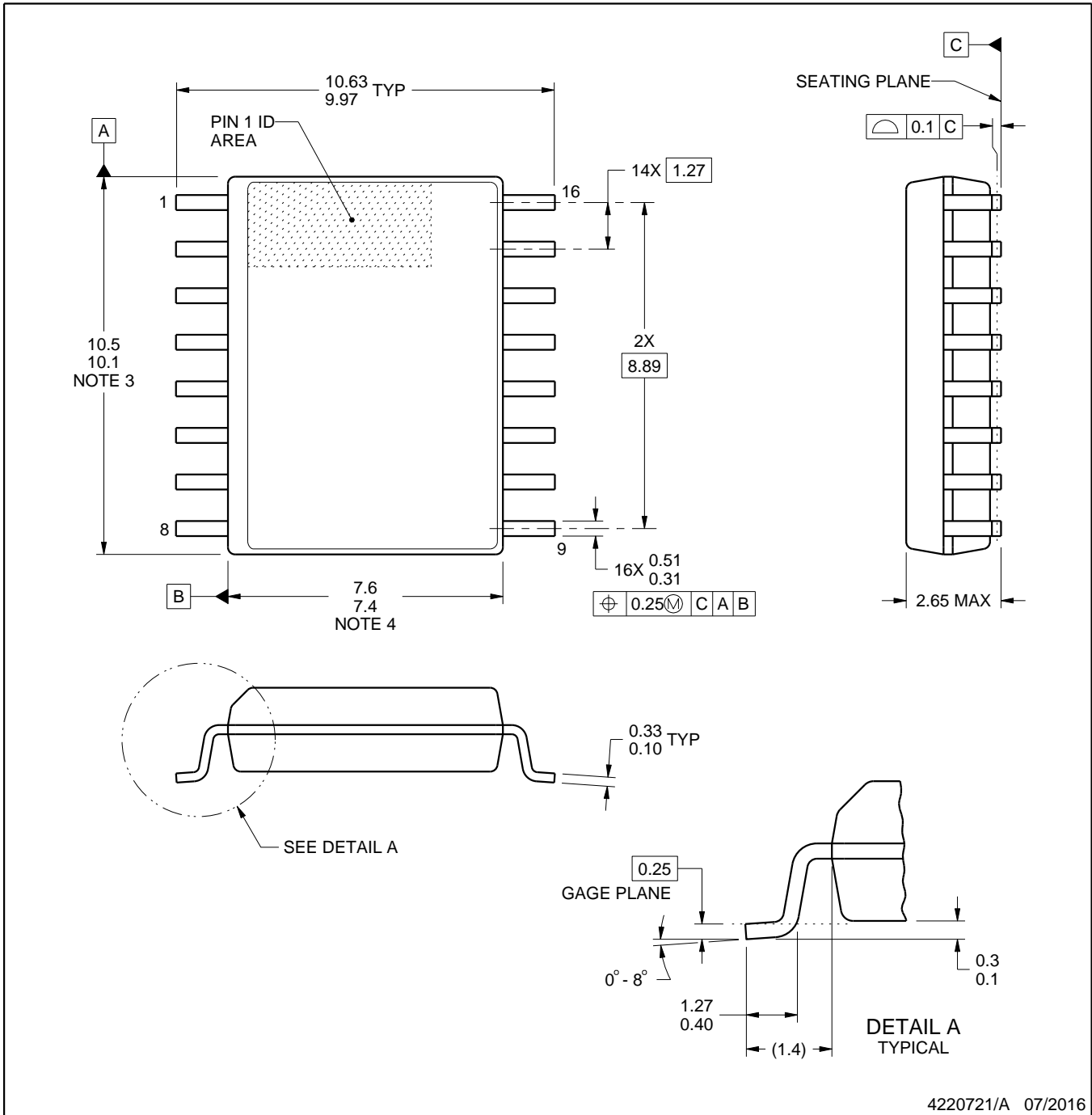

4220721/A 07/2016

## NOTES:

1. All linear dimensions are in millimeters. Dimensions in parenthesis are for reference only. Dimensioning and tolerancing per ASME Y14.5M.
2. This drawing is subject to change without notice.
3. This dimension does not include mold flash, protrusions, or gate burrs. Mold flash, protrusions, or gate burrs shall not exceed 0.15 mm, per side.
4. This dimension does not include interlead flash. Interlead flash shall not exceed 0.25 mm, per side.
5. Reference JEDEC registration MS-013.

# EXAMPLE BOARD LAYOUT

DW0016A

SOIC - 2.65 mm max height

SOIC



LAND PATTERN EXAMPLE  
SCALE:7X



SOLDER MASK DETAILS

4220721/A 07/2016

NOTES: (continued)

6. Publication IPC-7351 may have alternate designs.

7. Solder mask tolerances between and around signal pads can vary based on board fabrication site.

# EXAMPLE STENCIL DESIGN

DW0016A

SOIC - 2.65 mm max height

SOIC

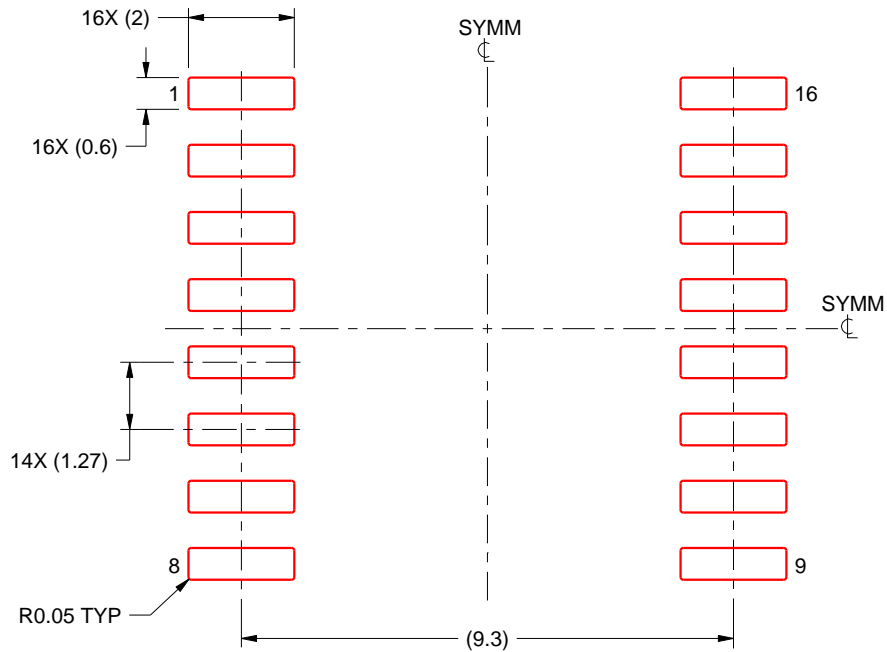

SOLDER PASTE EXAMPLE  
BASED ON 0.125 mm THICK STENCIL  
SCALE:7X

4220721/A 07/2016

NOTES: (continued)

8. Laser cutting apertures with trapezoidal walls and rounded corners may offer better paste release. IPC-7525 may have alternate design recommendations.
9. Board assembly site may have different recommendations for stencil design.

**RGT 16**

**GENERIC PACKAGE VIEW**

**VQFN - 1 mm max height**

PLASTIC QUAD FLATPACK - NO LEAD

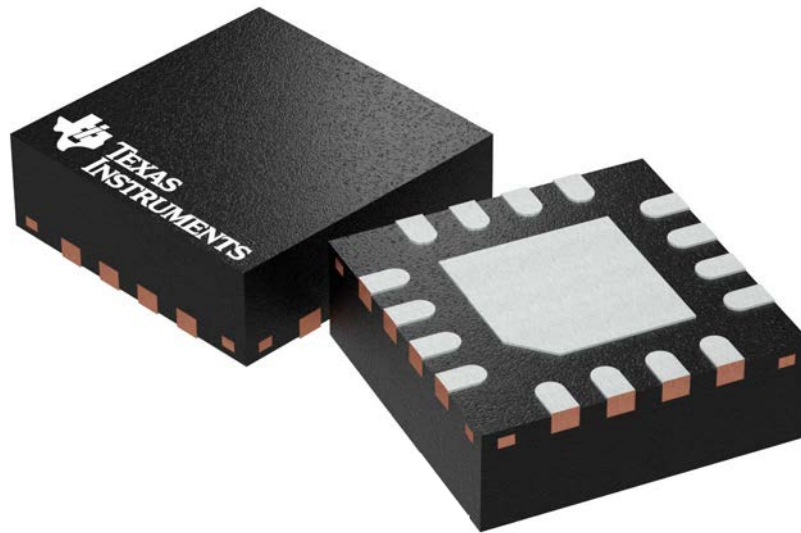

Images above are just a representation of the package family, actual package may vary.  
Refer to the product data sheet for package details.

4203495/1

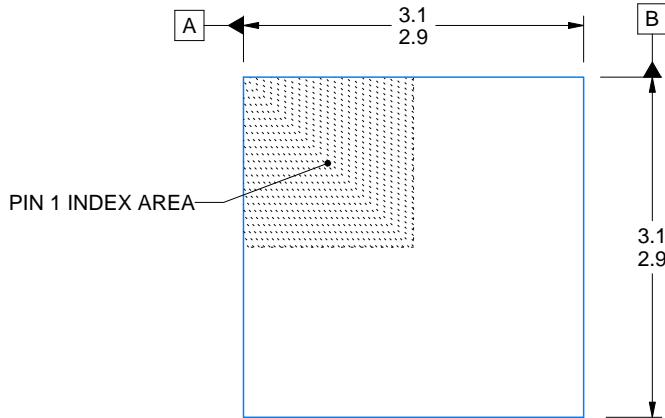
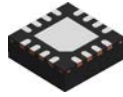

SIDE WALL METAL THICKNESS DIM A	
OPTION 1	OPTION 2
0.1	0.2

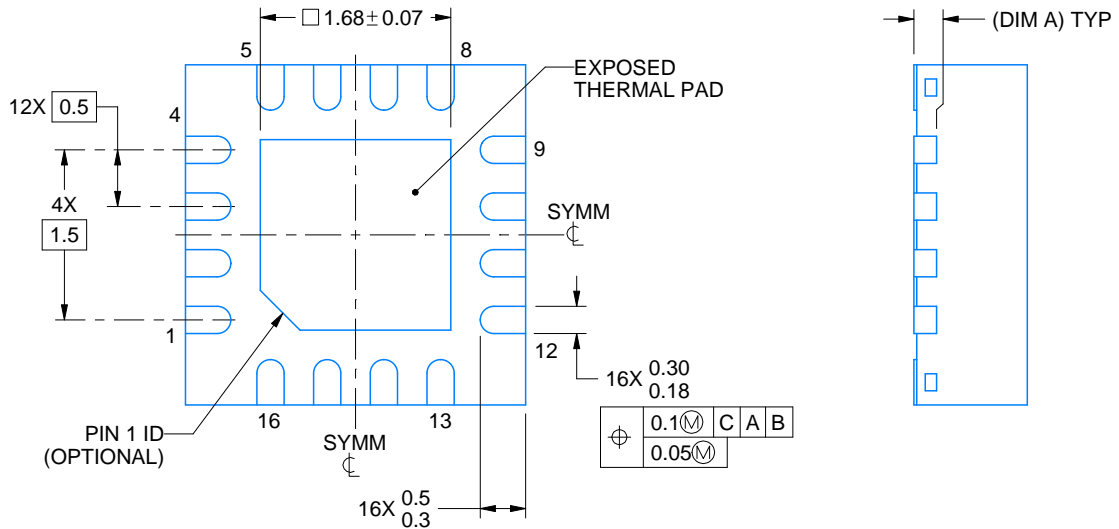
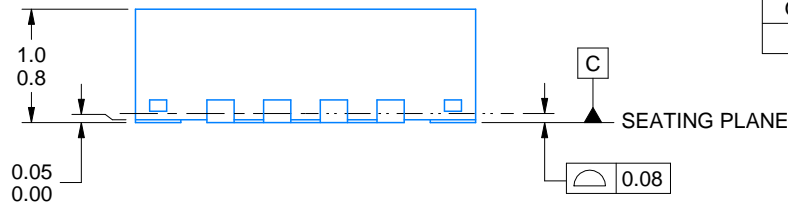

4222419/D 04/2022

NOTES:

1. All linear dimensions are in millimeters. Any dimensions in parenthesis are for reference only. Dimensioning and tolerancing per ASME Y14.5M.
2. This drawing is subject to change without notice.
3. The package thermal pad must be soldered to the printed circuit board for thermal and mechanical performance.

# EXAMPLE BOARD LAYOUT

RGT0016C

VQFN - 1 mm max height

PLASTIC QUAD FLATPACK - NO LEAD

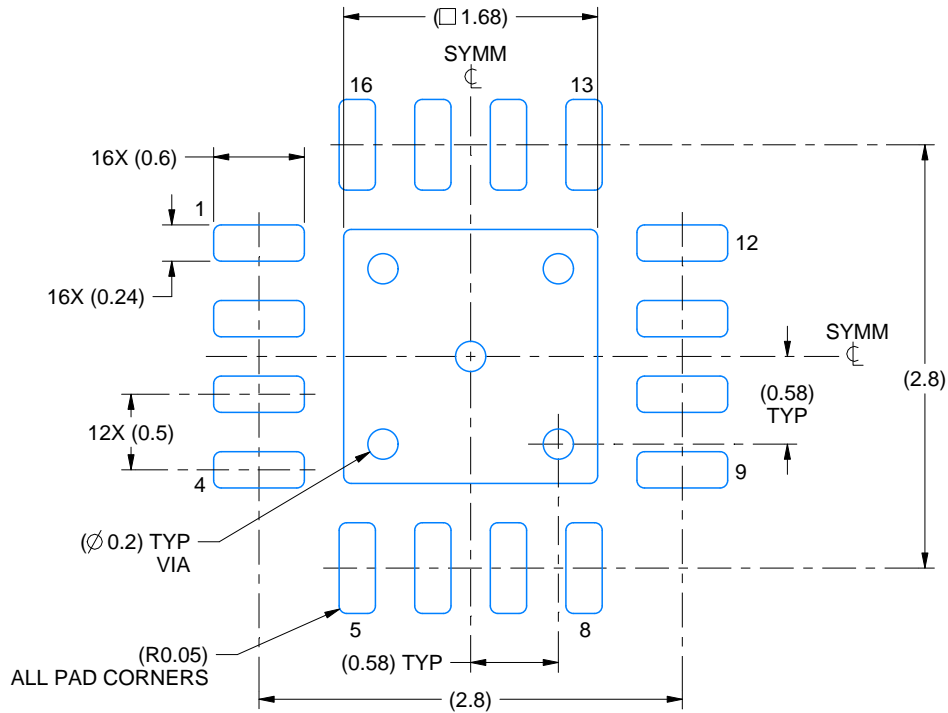

LAND PATTERN EXAMPLE  
EXPOSED METAL SHOWN  
SCALE:20X

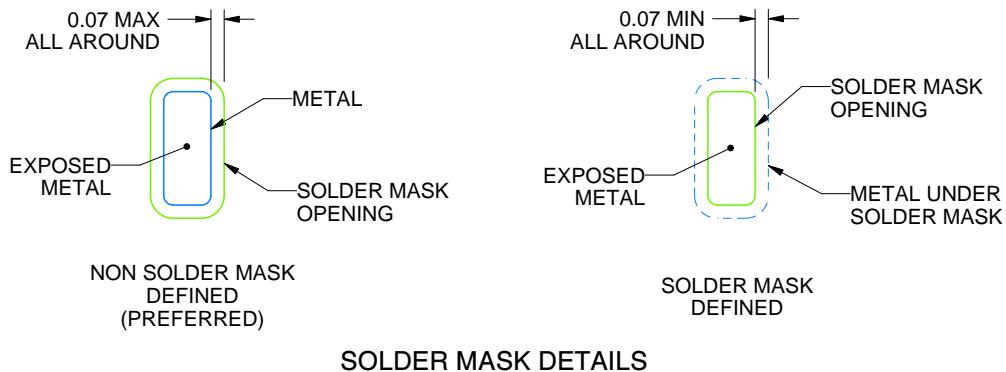

SOLDER MASK DETAILS

4222419/D 04/2022

NOTES: (continued)

4. This package is designed to be soldered to a thermal pad on the board. For more information, see Texas Instruments literature number SLUA271 ([www.ti.com/lit/slua271](http://www.ti.com/lit/slua271)).
5. Vias are optional depending on application, refer to device data sheet. If any vias are implemented, refer to their locations shown on this view. It is recommended that vias under paste be filled, plugged or tented.

# EXAMPLE STENCIL DESIGN

RGT0016C

VQFN - 1 mm max height

PLASTIC QUAD FLATPACK - NO LEAD

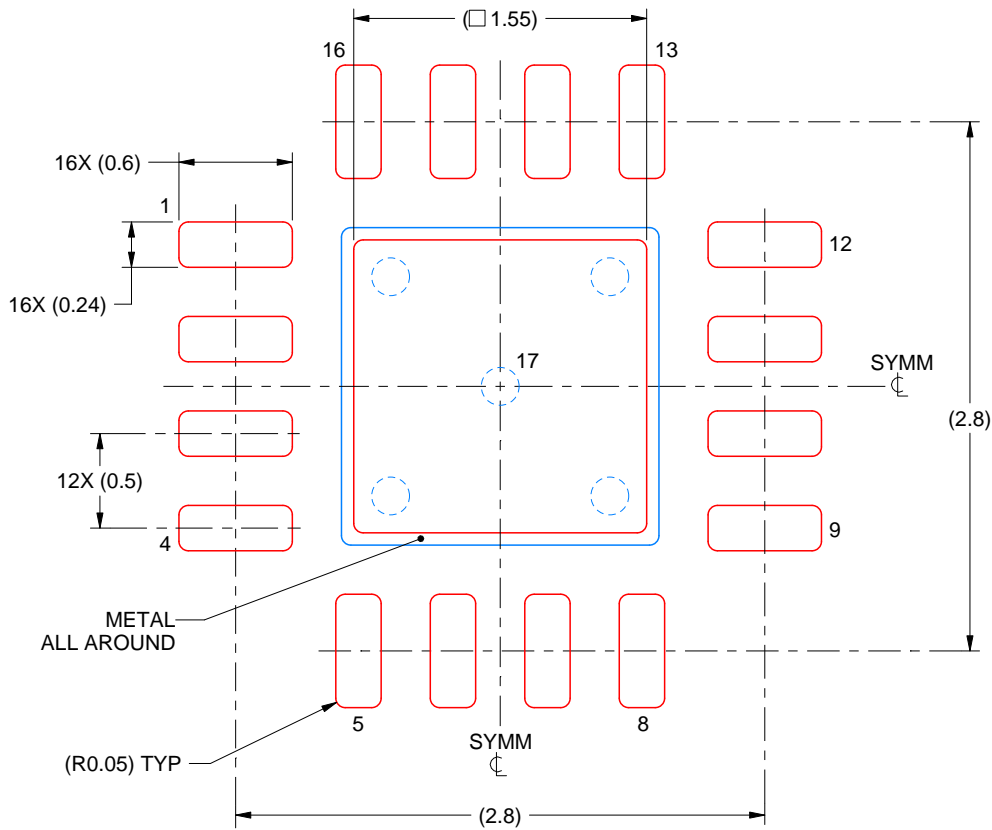

**SOLDER PASTE EXAMPLE**  
BASED ON 0.125 mm THICK STENCIL

EXPOSED PAD 17:  
85% PRINTED SOLDER COVERAGE BY AREA UNDER PACKAGE  
SCALE:25X

4222419/D 04/2022

NOTES: (continued)

6. Laser cutting apertures with trapezoidal walls and rounded corners may offer better paste release. IPC-7525 may have alternate design recommendations.

## IMPORTANT NOTICE AND DISCLAIMER

TI PROVIDES TECHNICAL AND RELIABILITY DATA (INCLUDING DATA SHEETS), DESIGN RESOURCES (INCLUDING REFERENCE DESIGNS), APPLICATION OR OTHER DESIGN ADVICE, WEB TOOLS, SAFETY INFORMATION, AND OTHER RESOURCES "AS IS" AND WITH ALL FAULTS, AND DISCLAIMS ALL WARRANTIES, EXPRESS AND IMPLIED, INCLUDING WITHOUT LIMITATION ANY IMPLIED WARRANTIES OF MERCHANTABILITY, FITNESS FOR A PARTICULAR PURPOSE OR NON-INFRINGEMENT OF THIRD PARTY INTELLECTUAL PROPERTY RIGHTS.

These resources are intended for skilled developers designing with TI products. You are solely responsible for (1) selecting the appropriate TI products for your application, (2) designing, validating and testing your application, and (3) ensuring your application meets applicable standards, and any other safety, security, regulatory or other requirements.

These resources are subject to change without notice. TI grants you permission to use these resources only for development of an application that uses the TI products described in the resource. Other reproduction and display of these resources is prohibited. No license is granted to any other TI intellectual property right or to any third party intellectual property right. TI disclaims responsibility for, and you will fully indemnify TI and its representatives against, any claims, damages, costs, losses, and liabilities arising out of your use of these resources.

TI's products are provided subject to [TI's Terms of Sale](#) or other applicable terms available either on [ti.com](https://www.ti.com) or provided in conjunction with such TI products. TI's provision of these resources does not expand or otherwise alter TI's applicable warranties or warranty disclaimers for TI products.

TI objects to and rejects any additional or different terms you may have proposed.

Mailing Address: Texas Instruments, Post Office Box 655303, Dallas, Texas 75265  
Copyright © 2024, Texas Instruments Incorporated

## Looking for pricing, stock, or lifecycle information?

Click below to explore more details on WIN SOURCE:

 [View TRSF3232ECDR on WIN SOURCE](#)

 [Texas Instruments](#) Information

## Optimize Your Supply Chain with WIN SOURCE Solutions

-  Global Sourcing Solution
-  Obsolete Management
-  Cost Control Management
-  Shortage Management
-  Alternative Solution
-  Excess Inventory Management