



**THE DATASHEET OF
TRS3253EIRSMR**



TRS3253E RS-232 Transceiver With Split Supply Pin for Logic Side

1 Features

- V_L Pin for Compatibility With Mixed-Voltage Systems Down to 1.8 V on Logic Side
- Enhanced ESD Protection on RIN Inputs and DOUT Outputs
 - ± 15 -kV IEC 61000-4-2 Air-Gap Discharge
 - ± 8 -kV IEC 61000-4-2 Contact Discharge
 - ± 15 -kV Human Body Model
- Low 300- μ A Supply Current
- Specified 1000-kbps Data Rate
- Auto Powerdown Plus Feature

2 Applications

- Hand-Held Equipment
- Cell Phones
- Battery-Powered Equipment
- Data Cables
- POS Equipment
- HDMI Switch Matrix
- Debug Ports

3 Description

The TRS3253E device is a three-driver and five-receiver RS-232 interface device, with split supply pins for mixed-signal operations without needing an external voltage translator. All RS-232 inputs and outputs are protected to ± 15 kV using the IEC 61000-4-2 Air-Gap Discharge method, ± 8 kV using the IEC 61000-4-2 Contact Discharge method, and ± 15 kV using the Human Body Model.

The charge pump requires only four capacitors for operation from a single 3.3-V or 5-V supply. The TRS3253E is capable of running at data rates up to 1000 kbps, while maintaining RS-232 compliant output levels.

The TRS3253E is available in a space-saving VQFN package (4-mm \times 4-mm RSM).

Auto-powerdown-plus automatically powers down drivers to reduce power after 30 seconds of inactivity. In powerdown state supply current is 10 μ A maximum.

Receiver input voltage status is available on $\overline{\text{INVALID}}$ logic output even when the device is in powerdown state.

Device Information⁽¹⁾

PART NUMBER	PACKAGE	BODY SIZE (NOM)
TRS3253ERSM	VQFN (32)	4.00 mm \times 4.00 mm

(1) For all available packages, see the orderable addendum at the end of the data sheet.

Simplified Diagram

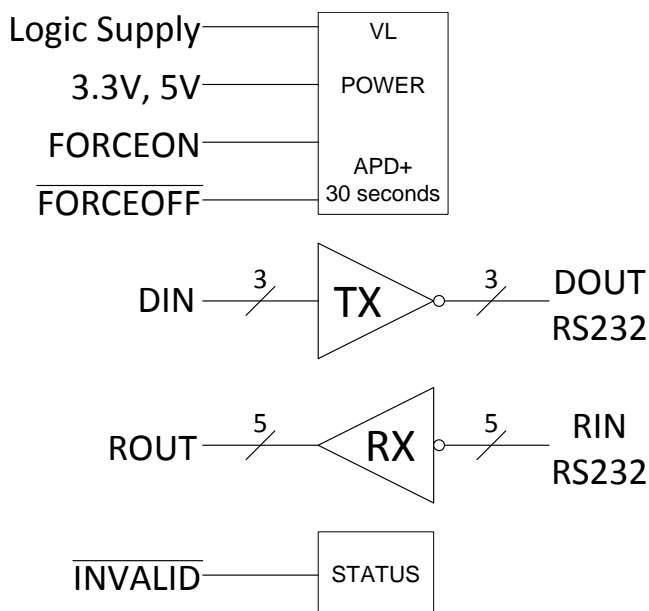

Table of Contents

1 Features 1 2 Applications 1 3 Description 1 4 Revision History 2 5 Pin Configuration and Functions 3 6 Specifications 5 6.1 Absolute Maximum Ratings 5 6.2 ESD Ratings 5 6.3 Recommended Operating Conditions 5 6.4 Thermal Information 6 6.5 Electrical Characteristics—Power 6 6.6 Electrical Characteristics—Driver 6 6.7 Electrical Characteristics—Receiver 6 6.8 Electrical Characteristics—Status 7 6.9 Switching Characteristics—Driver 7 6.10 Switching Characteristics—Receiver 7 6.11 Switching Characteristics—Power and Status 8 6.12 Typical Characteristics 9 7 Parameter Measurement Information 10	8 Detailed Description 13 8.1 Overview 13 8.2 Functional Block Diagram 13 8.3 Feature Description 13 8.4 Device Functional Modes 14 9 Application and Implementation 15 9.1 Application Information 15 9.2 Typical Application 15 10 Power Supply Recommendations 18 11 Layout 18 11.1 Layout Guidelines 18 11.2 Layout Example 18 12 Device and Documentation Support 19 12.1 Receiving Notification of Documentation Updates 19 12.2 Community Resources 19 12.3 Trademarks 19 12.4 Electrostatic Discharge Caution 19 12.5 Glossary 19 13 Mechanical, Packaging, and Orderable Information 19
--	--

4 Revision History

NOTE: Page numbers for previous revisions may differ from page numbers in the current version.

Changes from Revision C (June 2015) to Revision D	Page
<ul style="list-style-type: none"> • Changed "IEC61000-4-2, Contact Discharge" from "8 kV" to "15 kV" in Features, Description, Overview and ESD Ratings 5 	5

Changes from Revision B (December 2013) to Revision C	Page
<ul style="list-style-type: none"> • Added <i>Device Information</i> table, <i>Pin Functions</i> table, <i>ESD Ratings</i> table, <i>Thermal Information</i> table, <i>Typical Characteristics</i>, <i>Feature Description</i> section, <i>Device Functional Modes</i>, <i>Application and Implementation</i> section, <i>Power Supply Recommendations</i> section, <i>Layout</i> section, <i>Device and Documentation Support</i> section, and <i>Mechanical, Packaging, and Orderable Information</i> section. 1 	1

5 Pin Configuration and Functions

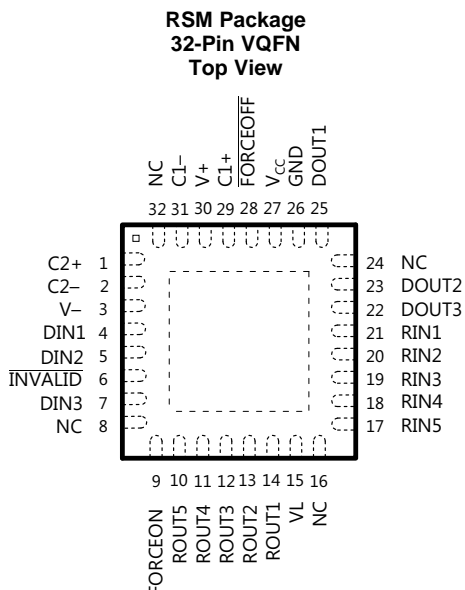

Power pad can be connected to GND or floating.

NC – No internal connection.

Pin Functions

PIN		I/O	DESCRIPTION
NAME	NO.		
C1+	29	—	Positive terminals of the voltage-doubler charge-pump capacitors
C2+	1		
C1-	31	—	Negative terminals of the voltage-doubler charge-pump capacitors
C2-	2		
DIN1	4	I	Driver inputs
DIN2	5		
DIN3	7		
DOUT1	25	O	RS-232 driver outputs
DOUT2	23		
DOUT3	22		
FORCEOFF	28	I	Auto-powerdown-plus control input
FORCEON	9	I	Auto-powerdown-plus control input
GND	26	—	Ground
INVALID	6	O	Invalid output pin. Active low when all RIN inputs are unpowered
NC	8	—	No connect pins (do not connect to these pins)
	16		
	24		
	32		
RIN1	21	I	RS-232 receiver inputs
RIN2	20		
RIN3	19		
RIN4	18		
RIN5	17		

Pin Functions (continued)

PIN		I/O	DESCRIPTION
NAME	NO.		
ROUT1	14	O	Receiver outputs. Swing between 0 and V_L
ROUT2	13		
ROUT3	12		
ROUT4	11		
ROUT5	10		
V_{CC}	27	—	3-V to 5.5-V supply voltage
V_L	15	—	Logic-level supply. All CMOS inputs and outputs are referenced to this supply
V+	30	O	5.5-V supply generated by the charge pump
V–	3	O	–5.5-V supply generated by the charge pump

6 Specifications

6.1 Absolute Maximum Ratings

over operating free-air temperature range (unless otherwise noted)⁽¹⁾

			MIN	MAX	UNIT
V _{CC} to GND			-0.3	6	V
V _L to GND			-0.3	V _{CC} + 0.3	
V+ to GND			-0.3	7	
V- to GND			0.3	-7	
V+ + V- ⁽²⁾				13	
V _I	Input voltage	DIN, $\overline{\text{FORCEOFF}}$, and FORCEON to GND	-0.3	6	V
		RIN to GND		±25	
V _O	Output voltage	DOUT to GND		±13.2	V
		ROUT to GND	-0.3	V _L + 0.3	
Continuous power dissipation		T _A = 85°C, 32-pin RSM (R _{θJA} = 37.2°C/W) ⁽³⁾		1747	mW
T _J	Junction temperature			150	°C
T _{stg}	Storage temperature		-65	150	°C

- (1) Stresses beyond those listed under *Absolute Maximum Ratings* may cause permanent damage to the device. These are stress ratings only, which do not imply functional operation of the device at these or any other conditions beyond those indicated under *Recommended Operating Conditions*. Exposure to absolute-maximum-rated conditions for extended periods may affect device reliability.
- (2) V+ and V- can have maximum magnitudes of 7 V, but their absolute difference cannot exceed 13 V.
- (3) Maximum power dissipation is a function of T_{J(max)}, R_{θJA}, and T_A. The maximum allowable power dissipation at any allowable ambient temperature is P_D = (T_{J(max)} - T_A) / R_{θJA}. Operating at the absolute maximum T_J of 150°C can affect reliability.

6.2 ESD Ratings

			VALUE	UNIT		
V _(ESD)	Electrostatic discharge	Human body model (HBM), per ANSI/ESDA/JEDEC JS-001 ⁽¹⁾	All pins except 17 to 23 and 25	±2000	V	
			Pins 17 to 23 and 25	±15000		
		Charged-device model (CDM), per JEDEC specification JESD22-C101 ⁽²⁾	All pins	±1500		
			IEC61000-4-2, Contact discharge	Pins 17 to 23 and 25		±8000
			IEC61000-4-2, Air-gap discharge	Pins 17 to 23 and 25		±15000

- (1) JEDEC document JEP155 states that 500-V HBM allows safe manufacturing with a standard ESD control process.
- (2) JEDEC document JEP157 states that 250-V CDM allows safe manufacturing with a standard ESD control process.

6.3 Recommended Operating Conditions

			MIN	MAX	UNIT
V _{CC}	Supply voltage		3	5.5	V
V _L	Supply voltage		1.65	V _{CC}	V
Input logic low	DIN, $\overline{\text{FORCEOFF}}$, FORCEON	V _L = 3 V or 5.5 V	0	0.8	V
		V _L = 2.3 V	0	0.6	
		V _L = 1.65 V	0	0.5	
Input logic high	DIN, $\overline{\text{FORCEOFF}}$, FORCEON	V _L = 5.5 V	2.4	V _L	V
		V _L = 3 V	2	V _L	
		V _L = 2.7 V	1.4	V _L	
		V _L = 1.95 V	1.25	V _L	
Operating temperature		TRS3253EIRSMR	-40	85	°C
Receiver input voltage			-25	25	V

6.4 Thermal Information

THERMAL METRIC ⁽¹⁾		TRS3253E	UNIT
		RSM (VQFN)	
		32 PINS	
R _{θJA}	Junction-to-ambient thermal resistance	37.2	°C/W
R _{θJC(top)}	Junction-to-case (top) thermal resistance	30.1	°C/W
R _{θJB}	Junction-to-board thermal resistance	7.8	°C/W
ψ _{JT}	Junction-to-top characterization parameter	0.4	°C/W
ψ _{JB}	Junction-to-board characterization parameter	7.6	°C/W
R _{θJC(bot)}	Junction-to-case (bottom) thermal resistance	2.4	°C/W

(1) For more information about traditional and new thermal metrics, see the [Semiconductor and IC Package Thermal Metrics](#) application report.

6.5 Electrical Characteristics—Power

over operating free-air temperature range, V_{CC} = V_L = 3 V to 5.5 V, C1–C4 = 0.1 μF (tested at 3.3 V ± 10%), C1 = 0.047 μF, C2–C4 = 0.33 μF (tested at 5 V ± 10%) (unless otherwise noted)⁽¹⁾

PARAMETER		TEST CONDITIONS	MIN	TYP ⁽²⁾	MAX	UNIT
I _I	Input leakage current	FORCEOFF, FORCEON		±0.01	±1	μA
I _{CC}	Supply current (T _A = 25°C)	Auto-powerdown plus disabled	No load, FORCEOFF and FORCEON at V _{CC}	0.5	1	mA
		Powered off	No load, FORCEOFF at GND	1	10	μA
		Auto-powerdown plus active	No load, FORCEOFF at V _{CC} , FORCEON at GND, All RIN are open or grounded	1	10	

(1) Testing supply conditions are C1–C4 = 0.1 μF at V_{CC} = 3.3 V ± 0.15 V; C1–C4 = 0.22 μF at V_{CC} = 3.3 V ± 0.3 V; and C1 = 0.047 μF and C2–C4 = 0.33 μF at V_{CC} = 5 V ± 0.5 V. (See [Figure 8](#))

(2) All typical values are at V_{CC} = 3.3 V or V_{CC} = 5 V, and T_A = 25°C.

6.6 Electrical Characteristics—Driver

over operating free-air temperature range, V_{CC} = V_L = 3 V to 5.5 V, C1–C4 = 0.1 μF (tested at 3.3 V ± 10%), C1 = 0.047 μF, C2–C4 = 0.33 μF (tested at 5 V ± 10%), T_A = T_{MIN} to T_{MAX} (unless otherwise noted)

PARAMETER	TEST CONDITIONS	MIN	TYP ⁽¹⁾	MAX	UNIT
V _{OH}	Output voltage swing	All driver outputs loaded with 3 kΩ to ground, V _{CC} = 3.1V to 5.5V	±5	±5.4	V
r _O	Output resistance	V _{CC} = V ₊ = V ₋ = 0, Driver output = ±2 V	300	10M	Ω
I _{OS}	Output short-circuit current	V _{T_OUT} = 0		±60	mA
I _{OZ}	Output leakage current	V _{T_OUT} = ±12 V, FORCEOFF = GND, V _{CC} = 3 V to 3.6 V		±25	μA
		V _{T_OUT} = ±12 V, FORCEOFF = GND, V _{CC} = 4.5 V to 5.5 V			
	Driver input hysteresis			0.5	V
	Input leakage current	DIN, FORCEOFF, FORCEON	±0.01	±1	μA

(1) Typical values are at V_{CC} = V_L = 3.3 V, T_A = 25°C

6.7 Electrical Characteristics—Receiver

over operating free-air temperature range, V_{CC} = V_L = 3 V to 5.5 V, C1–C4 = 0.1 μF (tested at 3.3 V ± 10%), C1 = 0.047 μF, C2–C4 = 0.33 μF (tested at 5 V ± 10%), T_A = T_{MIN} to T_{MAX} (unless otherwise noted)

PARAMETER	TEST CONDITIONS	MIN	TYP ⁽¹⁾	MAX	UNIT
I _{off}	Output leakage current	ROUT, receivers disabled	±0.05	±10	μA
V _{OL}	Output voltage low	I _{OUT} = 1.6 mA		0.4	V
V _{OH}	Output voltage high	I _{OUT} = -1 mA	V _L - 0.6	V _L - 0.1	V

(1) Typical values are at V_{CC} = V_L = 3.3 V, T_A = 25°C

Electrical Characteristics—Receiver (continued)

over operating free-air temperature range, $V_{CC} = V_L = 3\text{ V}$ to 5.5 V , $C1\text{--}C4 = 0.1\ \mu\text{F}$ (tested at $3.3\text{ V} \pm 10\%$), $C1 = 0.047\ \mu\text{F}$, $C2\text{--}C4 = 0.33\ \mu\text{F}$ (tested at $5\text{ V} \pm 10\%$), $T_A = T_{MIN}$ to T_{MAX} (unless otherwise noted)

PARAMETER		TEST CONDITIONS		MIN	TYP ⁽¹⁾	MAX	UNIT
V_{IT-}	Input threshold low	$T_A = 25^\circ\text{C}$	$V_L = 5\text{ V}$	0.8	1.2		V
			$V_L = 3.3\text{ V}$	0.6	1.5		
V_{IT+}	Input threshold high	$T_A = 25^\circ\text{C}$	$V_L = 5\text{ V}$		1.8	2.4	V
			$V_L = 3.3\text{ V}$		1.5	2.4	
V_{hys}	Input hysteresis				0.5		V
	Input resistance	$T_A = 25^\circ\text{C}$		3	5	7	k Ω

6.8 Electrical Characteristics—Status

over recommended ranges of supply voltage and operating free-air temperature (unless otherwise noted)

PARAMETER		TEST CONDITIONS		MIN	MAX	UNIT
$V_{IT+(valid)}$	Receiver input threshold for INVALID high-level output voltage	FORCEON = GND, $\overline{\text{FORCEOFF}} = V_L$			2.7	V
$V_{IT-(valid)}$	Receiver input threshold for INVALID high-level output voltage	FORCEON = GND, $\overline{\text{FORCEOFF}} = V_L$		-2.7		V
$V_{T(invalid)}$	Receiver input threshold for INVALID low-level output voltage	FORCEON = GND, $\overline{\text{FORCEOFF}} = V_L$		-0.3	0.3	V
V_{OH}	INVALID high-level output voltage	$I_{OH} = -1\text{ mA}$, FORCEON = GND, $\overline{\text{FORCEOFF}} = V_L$		$V_L - 0.6$		V
V_{OL}	INVALID low-level output voltage	$I_{OL} = 1.6\text{ mA}$, FORCEON = GND, $\overline{\text{FORCEOFF}} = V_L$			0.4	V

6.9 Switching Characteristics—Driver

over operating free-air temperature range, $V_{CC} = V_L = 3\text{ V}$ to 5.5 V , $C1\text{--}C4 = 0.1\ \mu\text{F}$ (tested at $3.3\text{ V} \pm 10\%$), $C1 = 0.047\ \mu\text{F}$, $C2\text{--}C4 = 0.33\ \mu\text{F}$ (tested at $5\text{ V} \pm 10\%$), $T_A = T_{MIN}$ to T_{MAX} (unless otherwise noted)

PARAMETER		TEST CONDITIONS		MIN	TYP ⁽¹⁾	MAX	UNIT
	Maximum data rate	$R_L = 3\text{ k}\Omega$, $C_L = 200\text{ pF}$, one driver switching		1000			kbps
	Time-to-exit powerdown	$ V_{T_OUT} > 3.7\text{ V}$			100		μs
$ t_{PHL} - t_{PLH} $	Driver skew ⁽²⁾				100		ns
	Transition-region slew rate	$V_{CC} = 3.3\text{ V}$, $T_A = 25^\circ\text{C}$, $R_L = 3\text{ k}\Omega$ to $7\text{ k}\Omega$, Measured from 3 V to -3 V or -3 V to 3 V	$C_L = 150\text{ pF}$ to 1000 pF	15		150	V/ μs

(1) Typical values are at $V_{CC} = V_L = 3.3\text{ V}$, $T_A = 25^\circ\text{C}$.

(2) Driver skew is measured at the driver zero crosspoint.

6.10 Switching Characteristics—Receiver

over operating free-air temperature range, $V_{CC} = V_L = 3\text{ V}$ to 5.5 V , $C1\text{--}C4 = 0.1\ \mu\text{F}$ (tested at $3.3\text{ V} \pm 10\%$), $C1 = 0.047\ \mu\text{F}$, $C2\text{--}C4 = 0.33\ \mu\text{F}$ (tested at $5\text{ V} \pm 10\%$), $T_A = T_{MIN}$ to T_{MAX} (unless otherwise noted)

PARAMETER		TEST CONDITIONS		MIN	TYP ⁽¹⁾	MAX	UNIT
t_{PHL}	Receiver propagation delay	Receiver input to receiver output, $C_L = 150\text{ pF}$		0.15			μs
t_{PLH}				0.15			
$t_{PHL} - t_{PLH}$	Receiver skew			50			ns
t_{en}	Receiver output enable time	From $\overline{\text{FORCEOFF}}$		200			
t_{dis}	Receiver output disable time	From $\overline{\text{FORCEOFF}}$		200			

(1) Typical values are at $V_{CC} = V_L = 3.3\text{ V}$, $T_A = 25^\circ\text{C}$.

6.11 Switching Characteristics—Power and Status

over recommended ranges of supply voltage and operating free-air temperature (unless otherwise noted) (see [Figure 7](#))

PARAMETER		MIN	TYP ⁽¹⁾	MAX	UNIT
t_{valid}	Propagation delay time, low- to high-level output		0.1		μs
t_{invalid}	Propagation delay time, high- to low-level output		50		
t_{en}	Supply enable time		25		
t_{dis}	Receiver or driver edge to auto-powerdown plus	15	30	60	s

(1) All typical values are at $V_{\text{CC}} = V_{\text{L}} = 3.3 \text{ V}$ and $T_{\text{A}} = 25^{\circ}\text{C}$.

6.12 Typical Characteristics

$V_{CC} = 3.3\text{ V}$

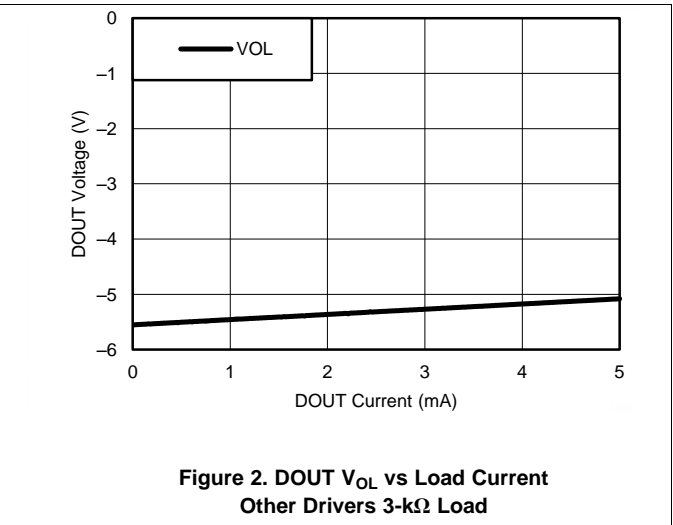
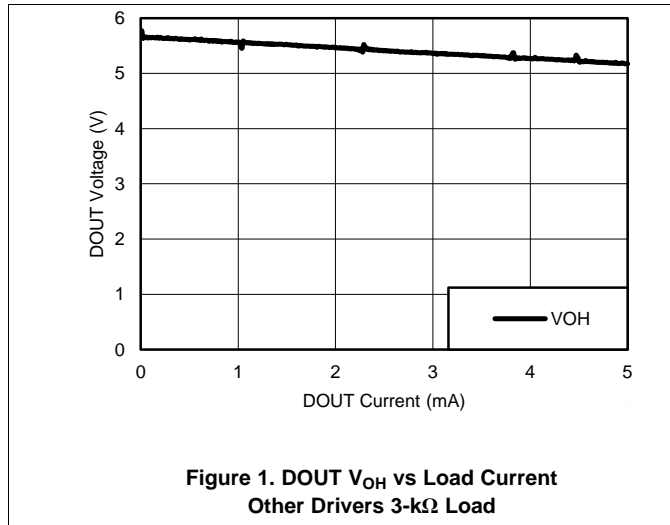

7 Parameter Measurement Information

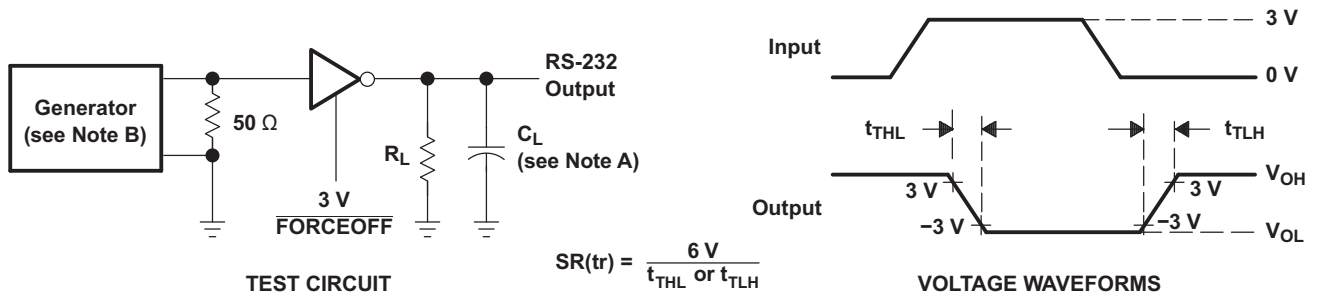

- A. C_L includes probe and jig capacitance.
- B. The pulse generator has the following characteristics: PRR = 250 kbit/s, $Z_O = 50\ \Omega$, 50% duty cycle, $t_r \leq 10\text{ ns}$, $t_f \leq 10\text{ ns}$.

Figure 3. Driver Slew Rate

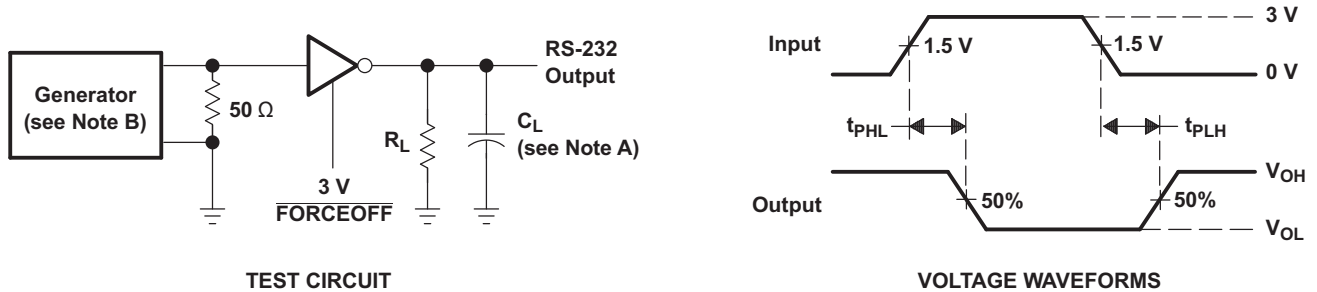

- A. C_L includes probe and jig capacitance.
- B. The pulse generator has the following characteristics: PRR = 250 kbit/s, $Z_O = 50\ \Omega$, 50% duty cycle, $t_r \leq 10\text{ ns}$, $t_f \leq 10\text{ ns}$.

Figure 4. Driver Pulse Skew

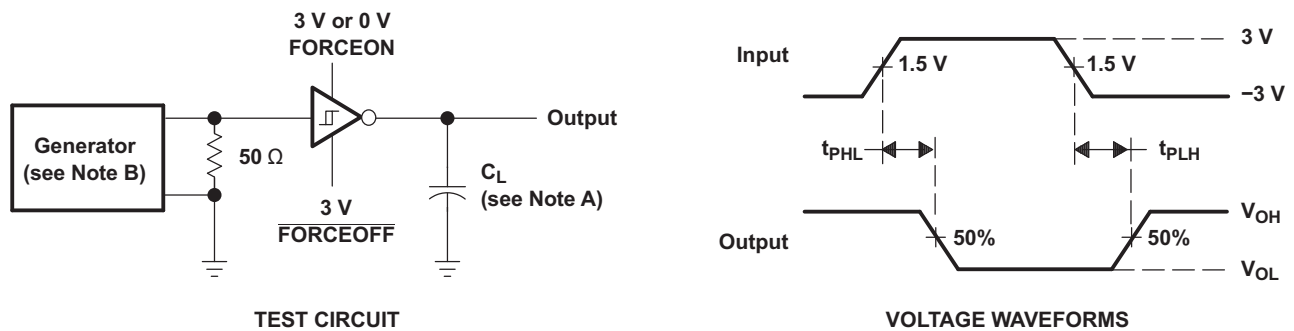

- A. C_L includes probe and jig capacitance.
- B. The pulse generator has the following characteristics: $Z_O = 50\ \Omega$, 50% duty cycle, $t_r \leq 10\text{ ns}$, $t_f \leq 10\text{ ns}$.

Figure 5. Receiver Propagation Delay Times

Parameter Measurement Information (continued)

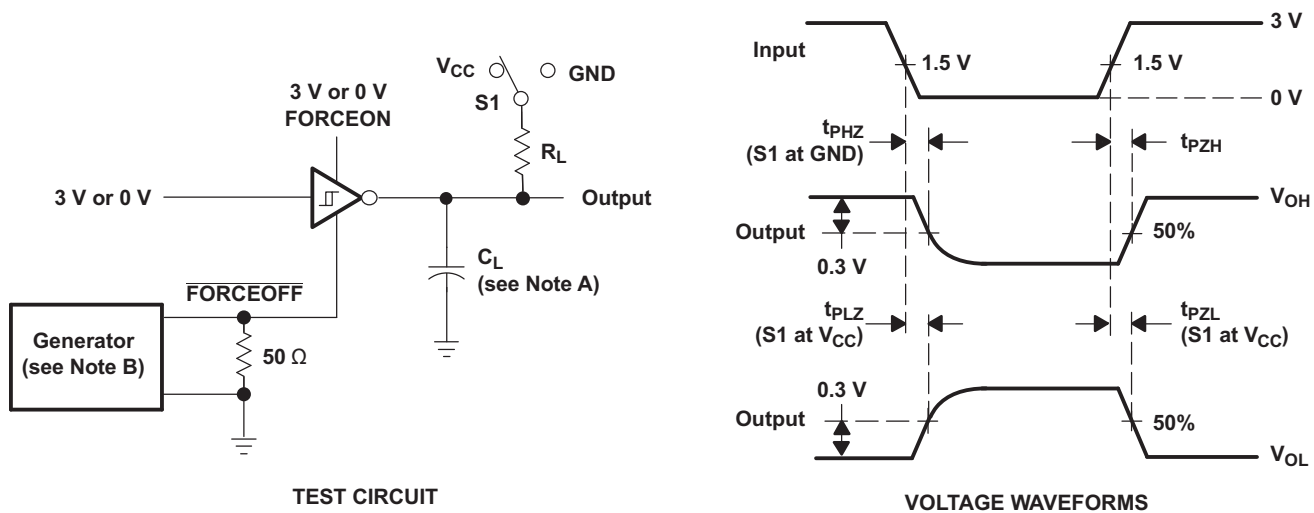

- A. C_L includes probe and jig capacitance.
- B. The pulse generator has the following characteristics: $Z_O = 50 \Omega$, 50% duty cycle, $t_r \leq 10 \text{ ns}$, $t_f \leq 10 \text{ ns}$.
- C. t_{PLZ} and t_{PHZ} are the same as t_{dis} .
- D. t_{PZL} and t_{PZH} are the same as t_{en} .

Figure 6. Receiver Enable and Disable Times

Parameter Measurement Information (continued)

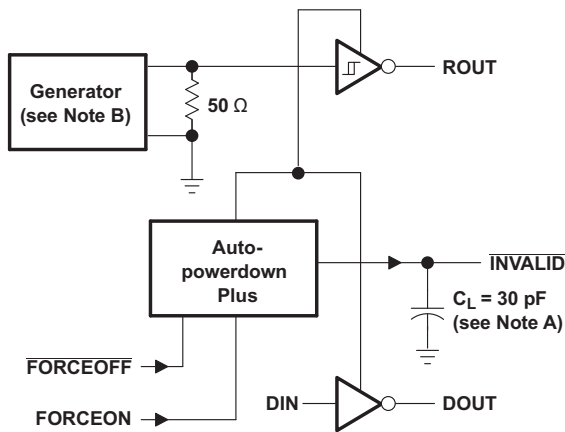

TEST CIRCUIT

- NOTES: A. C_L includes probe and jig capacitance.
 B. The pulse generator has the following characteristics: PRR = 5 kbit/s, $Z_0 = 50 \Omega$, 50% duty cycle, $t_r \leq 10$ ns, $t_f \leq 10$ ns.

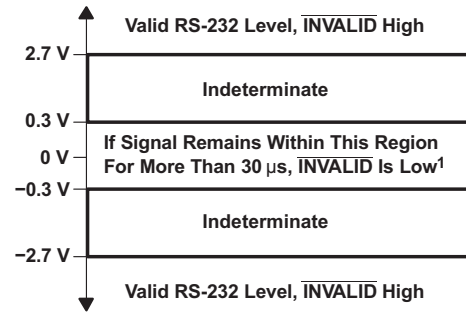

† Auto-powerdown plus disables drivers and reduces supply current to 1 μ A.

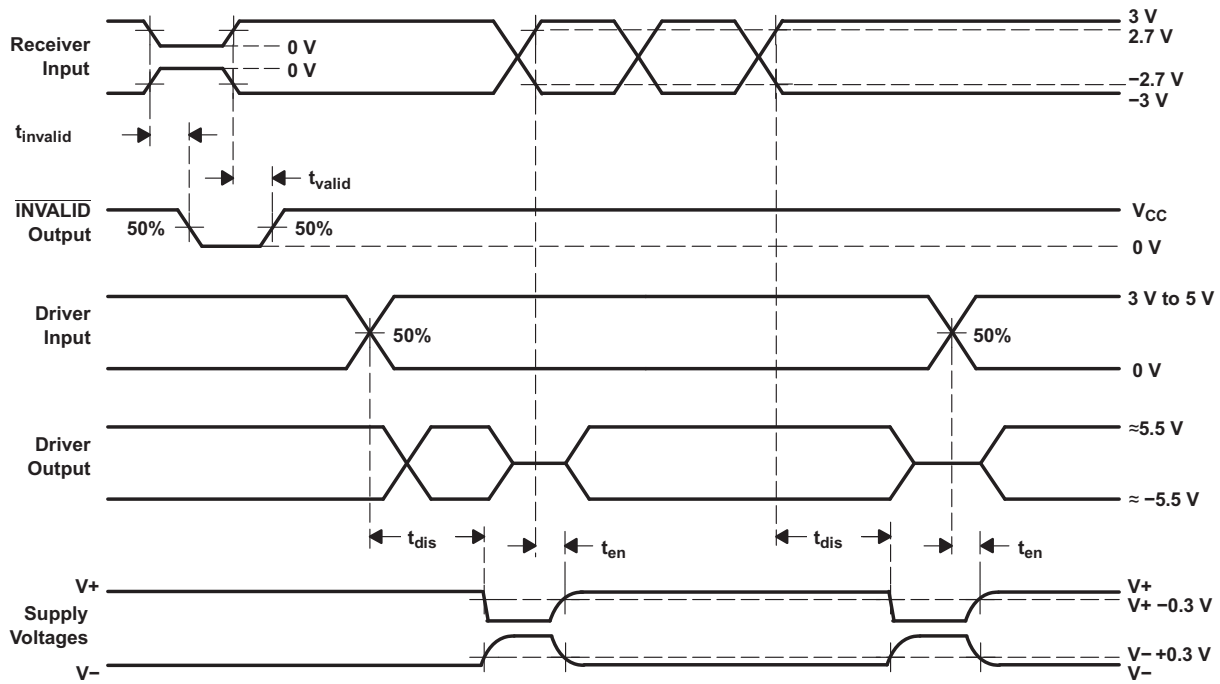

Voltage Waveforms and Timing Diagrams

Figure 7. $\overline{\text{INVALID}}$ Propagation-Delay Times and Supply-Enabling Time

8 Detailed Description

8.1 Overview

The TRS3253E is a three-driver and five-receiver RS-232 interface device, with split-supply pins for mixed-signal operations. All RS-232 inputs and outputs are protected to ± 15 kV using the IEC 61000-4-2 Air-Gap Discharge method, ± 8 kV using the IEC 61000-4-2 Contact Discharge method, and ± 15 kV using the Human-Body Model. The charge pump requires only four small 0.1- μ F capacitors for operation from a 3.3-V supply. The TRS3253E is capable of running at data rates up to 1000 kbps, while maintaining RS-232-compliant output levels. The TRS3253E is available in a space-saving VQFN package (4-mm \times 4-mm RSM).

The TRS3253E has a unique V_L pin that allows operation in mixed-logic voltage systems. Both driver input (DIN) and receiver output (ROUT) logic levels are pin programmable through the V_L pin. This eliminates the need for additional voltage level shifter while interfacing with low-voltage microcontroller or UARTs.

Auto-powerdown plus can be disabled when FORCEON and FORCEOFF are high. With auto-powerdown plus enabled, the device activates automatically when a valid signal change is applied to any receiver or driver input. After 30 seconds of inactivity the device will automatically power down to save power.

INVALID is high (valid data) if any receiver input voltage is greater than 2.7 V or less than -2.7 V, or has been between -0.3 V and 0.3 V for less than 30 μ s. INVALID is low (invalid data) if all receiver input voltages are between -0.3 V and 0.3 V for more than 30 μ s. Refer to Figure 7 for receiver input levels.

8.2 Functional Block Diagram

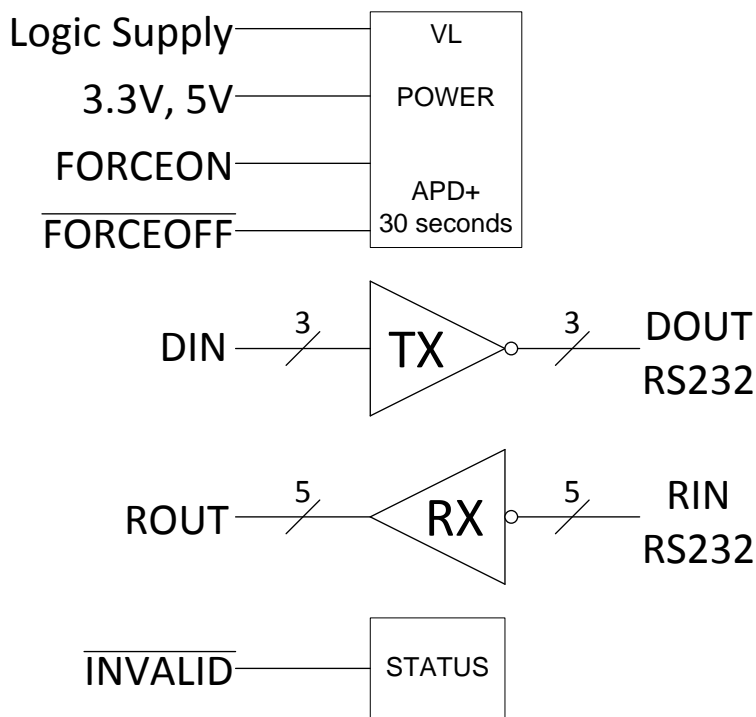

8.3 Feature Description

8.3.1 Power

The power block increases, inverts, and regulates voltage at $V+$ and $V-$ pins using a charge pump that requires four external capacitors. Logic voltage translation is controlled by voltage provided to V_L pin. Auto-powerdown-plus feature is controlled by FORCEON and FORCEOFF inputs. See Table 1 and Table 2.

When TRS3253E is unpowered, it can be safely connected to an active remote RS232 device.

Feature Description (continued)

8.3.2 RS232 Driver

Three drivers interface standard logic level to RS232 levels. All DIN inputs must be valid high or low.

8.3.3 RS232 Receiver

Five receivers interface RS232 levels to standard logic levels. An open input will result in a high output on ROUT. Each RIN input includes an internal standard RS232 load.

8.3.4 RS232 Status

The $\overline{\text{INVALID}}$ output goes low when all RIN inputs are unpowered for more than 30 μs . The $\overline{\text{INVALID}}$ output goes high when any receiver has a valid input. The $\overline{\text{INVALID}}$ output is active when V_L is powered irregardless of FORCEON and $\overline{\text{FORCEOFF}}$ inputs. See [Table 3](#).

8.4 Device Functional Modes

Table 1. Each Driver⁽¹⁾

INPUTS				OUTPUT	DRIVER STATUS
DIN	FORCEON	$\overline{\text{FORCEOFF}}$	TIME ELAPSED SINCE LAST RIN OR DIN TRANSITION	DOUT	
X	X	L	X	Z	Powered off
L	H	H	X	H	Normal operation with auto-powerdown plus disabled
H	H	H	X	L	
L	L	H	<30 s	H	Normal operation with auto-powerdown plus enabled
H	L	H	<30 s	L	
L	L	H	>30 s	Z	Powered off by auto-powerdown plus feature
H	L	H	>30 s	Z	

(1) H = high level, L = low level, X = irrelevant, Z = high impedance.

Table 2. Each Receiver⁽¹⁾

INPUTS			OUTPUT	RECEIVER STATUS
RIN	$\overline{\text{FORCEOFF}}$	TIME ELAPSED SINCE LAST RIN OR DIN TRANSITION	ROUT	
X	L	X	Z	Powered off
L	H	<30 s	H	Normal operation with auto-powerdown plus disabled/enabled
H	H	<30 s	L	
Open	H	<30 s	H	

(1) H = high level, L = low level, X = irrelevant, Z = high impedance (off), Open = input disconnected or connected driver off.

Table 3. $\overline{\text{INVALID}}$ ⁽¹⁾

INPUTS				OUTPUT
RIN1 – RIN5	FORCEON	$\overline{\text{FORCEOFF}}$	TIME ELAPSED SINCE LAST RIN OR DIN TRANSITION	$\overline{\text{INVALID}}$
Any L or H	X	X	X	H
All Open	X	X	X	L

(1) H = high level, L = low level, X = irrelevant, Z = high impedance (off), Open = input disconnected or connected driver off.

9 Application and Implementation

NOTE

Information in the following applications sections is not part of the TI component specification, and TI does not warrant its accuracy or completeness. TI's customers are responsible for determining suitability of components for their purposes. Customers should validate and test their design implementation to confirm system functionality.

9.1 Application Information

This device can be used in any application where an RS232 line driver or receiver is required. One benefit of this device is its ESD protection, which helps protect other components on the board when the RS232 lines are tied to a physical connector.

9.2 Typical Application

ROUT and DIN connect to UART or general purpose logic lines. FORCEON and $\overline{\text{FORCEOFF}}$ may be connected general purpose logic lines or tied to ground or V_L . INVALID may be connected to a general purpose logic line or left unconnected. RIN and DOUT lines connect to a RS232 connector or cable. DIN, FORCEON, and $\overline{\text{FORCEOFF}}$ inputs must not be left unconnected. For proper operation, add capacitors as shown in [Figure 8](#).

Typical Application (continued)

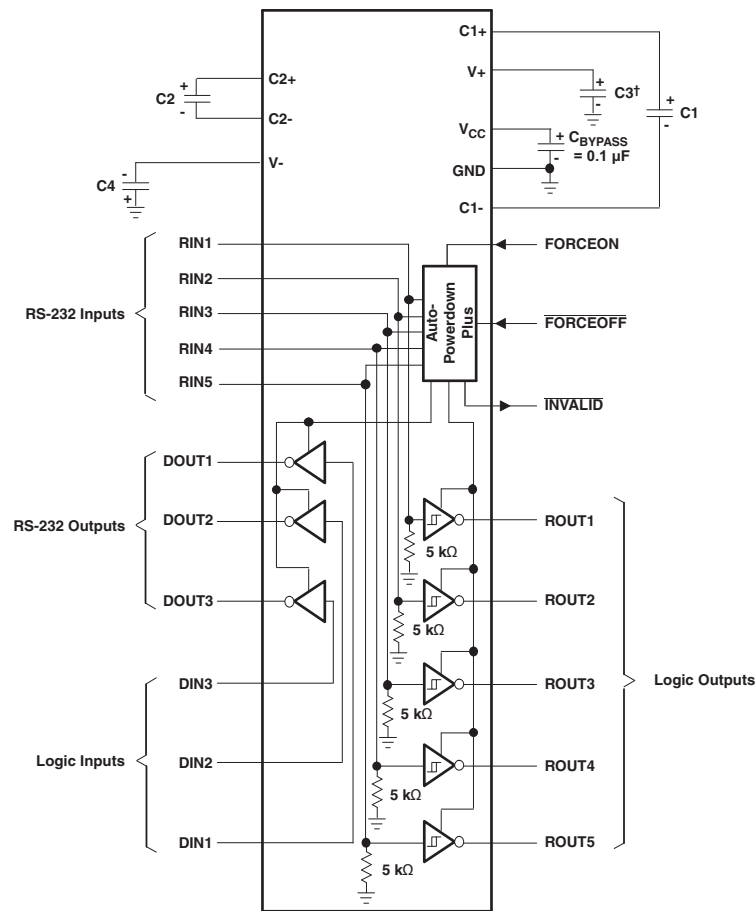

† C3 can be connected to V_{CC} or GND.

NOTES: A. Resistor values shown are nominal.
 B. Nonpolarized ceramic capacitors are acceptable. If polarized tantalum or electrolytic capacitors are used, they should be connected as shown.

V_{CC} vs CAPACITOR VALUES

V _{CC}	C1	C2, C3, and C4
3.3 V ± 0.3 V	0.1 μF	0.1 μF
5 V ± 0.5 V	0.047 μF	0.33 μF
3 V to 5.5 V	0.1 μF	0.47 μF

Figure 8. Typical Operating Circuit and Capacitor Values

9.2.1 Design Requirements

- Recommended V_{CC} is 3.3 V or 5 V. 3 V to 5.5 V is also possible
- Maximum recommended bit rate is 1000 kbps
- Use capacitors as shown in [Figure 8](#)

9.2.2 Detailed Design Procedure

- All DIN, FORCEOFF, and FORCEON inputs must be connected to valid low or high logic levels.
- Select capacitor values based on V_{CC} level for best performance.

9.2.3 Application Curve

Driver input as top waveform and driver output as bottom waveform.

- 3.3-V V_{CC}
- 1000-kbit/s data rate

10 Power Supply Recommendations

V_{CC} must be between 3.3 and 5 V. Capacitors must be selected according to the table in [Figure 8](#).

11 Layout

11.1 Layout Guidelines

Keep the external capacitor traces short. This is more important on C1 and C2 nodes that have the fastest rise and fall times.

11.2 Layout Example

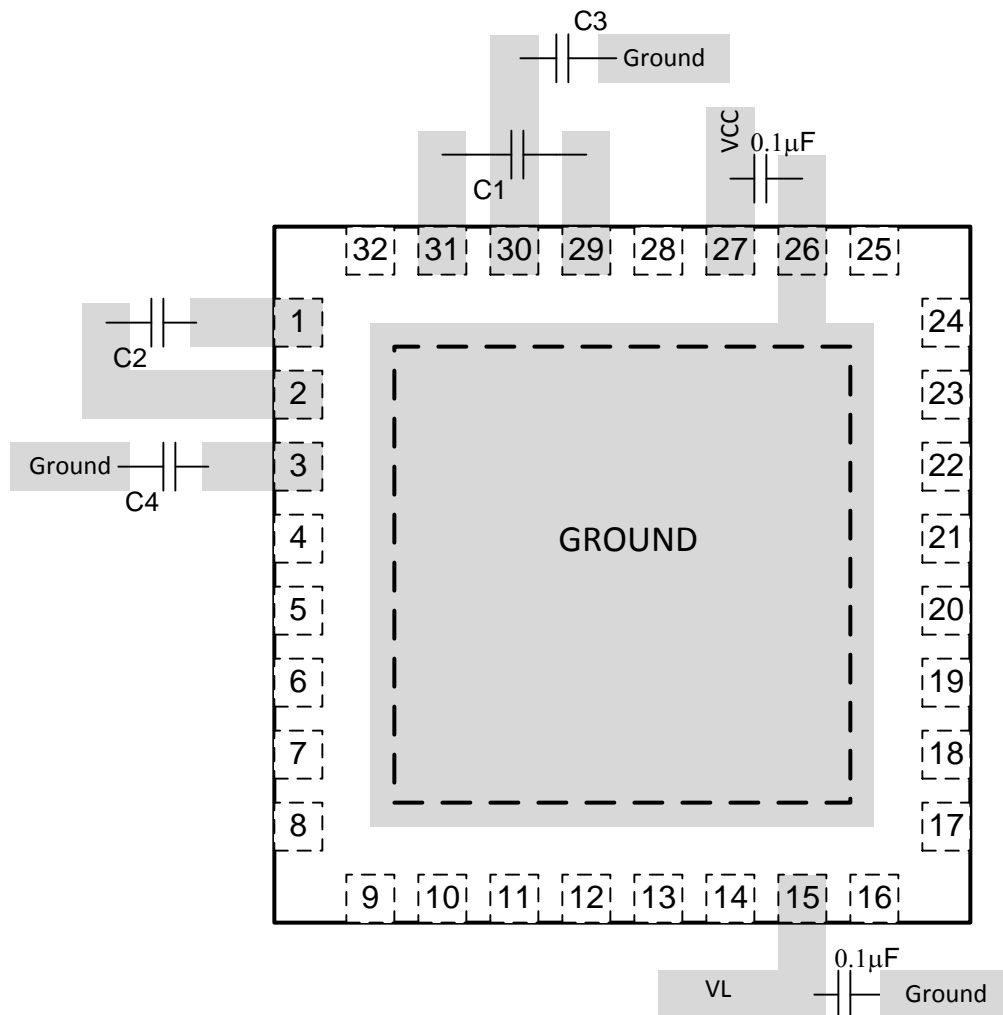

Figure 10. Layout Diagram

12 Device and Documentation Support

12.1 Receiving Notification of Documentation Updates

To receive notification of documentation updates, navigate to the device product folder on ti.com. In the upper right corner, click on *Alert me* to register and receive a weekly digest of any product information that has changed. For change details, review the revision history included in any revised document.

12.2 Community Resources

The following links connect to TI community resources. Linked contents are provided "AS IS" by the respective contributors. They do not constitute TI specifications and do not necessarily reflect TI's views; see TI's [Terms of Use](#).

TI E2E™ Online Community *TI's Engineer-to-Engineer (E2E) Community*. Created to foster collaboration among engineers. At e2e.ti.com, you can ask questions, share knowledge, explore ideas and help solve problems with fellow engineers.

Design Support *TI's Design Support* Quickly find helpful E2E forums along with design support tools and contact information for technical support.

12.3 Trademarks

E2E is a trademark of Texas Instruments.
All other trademarks are the property of their respective owners.

12.4 Electrostatic Discharge Caution



These devices have limited built-in ESD protection. The leads should be shorted together or the device placed in conductive foam during storage or handling to prevent electrostatic damage to the MOS gates.

12.5 Glossary

[SLYZ022](#) — *TI Glossary*.

This glossary lists and explains terms, acronyms, and definitions.

13 Mechanical, Packaging, and Orderable Information

The following pages include mechanical, packaging, and orderable information. This information is the most current data available for the designated devices. This data is subject to change without notice and revision of this document. For browser based versions of this data sheet, refer to the left hand navigation.

PACKAGING INFORMATION

Orderable Device	Status (1)	Package Type	Package Drawing	Pins	Package Qty	Eco Plan (2)	Lead finish/ Ball material (6)	MSL Peak Temp (3)	Op Temp (°C)	Device Marking (4/5)	Samples
TRS3253EIRSMR	ACTIVE	VQFN	RSM	32	3000	RoHS & Green	NIPDAU	Level-2-260C-1 YEAR	-40 to 85	RS53EI	Samples

(1) The marketing status values are defined as follows:

ACTIVE: Product device recommended for new designs.

LIFEBUY: TI has announced that the device will be discontinued, and a lifetime-buy period is in effect.

NRND: Not recommended for new designs. Device is in production to support existing customers, but TI does not recommend using this part in a new design.

PREVIEW: Device has been announced but is not in production. Samples may or may not be available.

OBSOLETE: TI has discontinued the production of the device.

(2) **RoHS:** TI defines "RoHS" to mean semiconductor products that are compliant with the current EU RoHS requirements for all 10 RoHS substances, including the requirement that RoHS substance do not exceed 0.1% by weight in homogeneous materials. Where designed to be soldered at high temperatures, "RoHS" products are suitable for use in specified lead-free processes. TI may reference these types of products as "Pb-Free".

RoHS Exempt: TI defines "RoHS Exempt" to mean products that contain lead but are compliant with EU RoHS pursuant to a specific EU RoHS exemption.

Green: TI defines "Green" to mean the content of Chlorine (Cl) and Bromine (Br) based flame retardants meet JS709B low halogen requirements of <=1000ppm threshold. Antimony trioxide based flame retardants must also meet the <=1000ppm threshold requirement.

(3) MSL, Peak Temp. - The Moisture Sensitivity Level rating according to the JEDEC industry standard classifications, and peak solder temperature.

(4) There may be additional marking, which relates to the logo, the lot trace code information, or the environmental category on the device.

(5) Multiple Device Markings will be inside parentheses. Only one Device Marking contained in parentheses and separated by a "-" will appear on a device. If a line is indented then it is a continuation of the previous line and the two combined represent the entire Device Marking for that device.

(6) Lead finish/Ball material - Orderable Devices may have multiple material finish options. Finish options are separated by a vertical ruled line. Lead finish/Ball material values may wrap to two lines if the finish value exceeds the maximum column width.

Important Information and Disclaimer: The information provided on this page represents TI's knowledge and belief as of the date that it is provided. TI bases its knowledge and belief on information provided by third parties, and makes no representation or warranty as to the accuracy of such information. Efforts are underway to better integrate information from third parties. TI has taken and continues to take reasonable steps to provide representative and accurate information but may not have conducted destructive testing or chemical analysis on incoming materials and chemicals. TI and TI suppliers consider certain information to be proprietary, and thus CAS numbers and other limited information may not be available for release.

In no event shall TI's liability arising out of such information exceed the total purchase price of the TI part(s) at issue in this document sold by TI to Customer on an annual basis.

OTHER QUALIFIED VERSIONS OF TRS3253E :

- Enhanced Product: [TRS3253E-EP](#)

NOTE: Qualified Version Definitions:

- Enhanced Product - Supports Defense, Aerospace and Medical Applications

TAPE AND REEL INFORMATION

QUADRANT ASSIGNMENTS FOR PIN 1 ORIENTATION IN TAPE

*All dimensions are nominal

Device	Package Type	Package Drawing	Pins	SPQ	Reel Diameter (mm)	Reel Width W1 (mm)	A0 (mm)	B0 (mm)	K0 (mm)	P1 (mm)	W (mm)	Pin1 Quadrant
TRS3253EIRSMR	VQFN	RSM	32	3000	330.0	12.4	4.25	4.25	1.15	8.0	12.0	Q2

TAPE AND REEL BOX DIMENSIONS

*All dimensions are nominal

Device	Package Type	Package Drawing	Pins	SPQ	Length (mm)	Width (mm)	Height (mm)
TRS3253EIRSMR	VQFN	RSM	32	3000	356.0	356.0	35.0

GENERIC PACKAGE VIEW

RSM 32

VQFN - 1 mm max height

4 x 4, 0.4 mm pitch

PLASTIC QUAD FLATPACK - NO LEAD

This image is a representation of the package family, actual package may vary.
Refer to the product data sheet for package details.

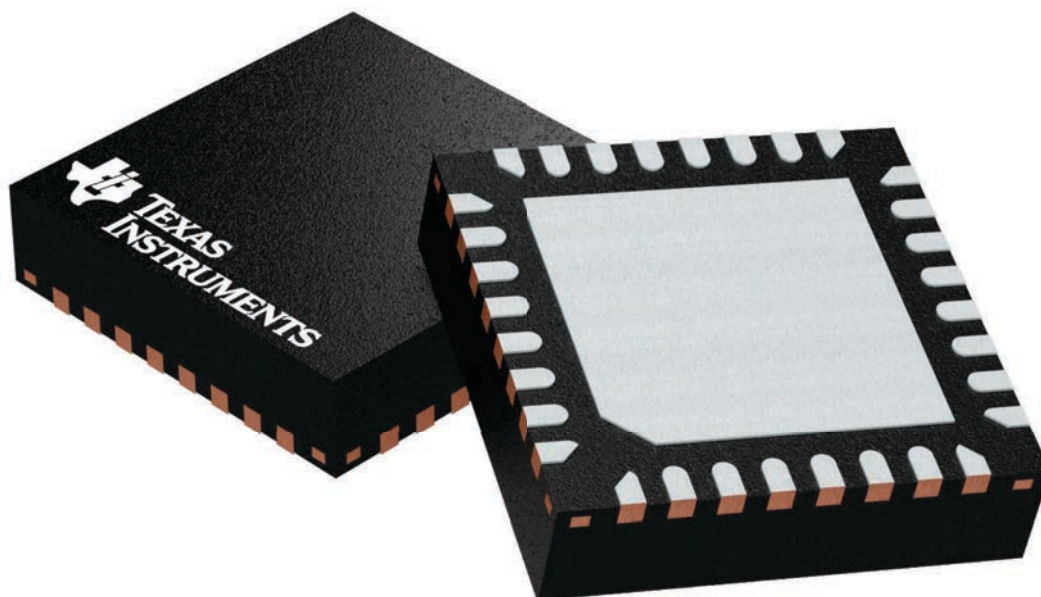

4224982/A

RSM0032B

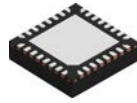

PACKAGE OUTLINE

VQFN - 1 mm max height

PLASTIC QUAD FLATPACK - NO LEAD

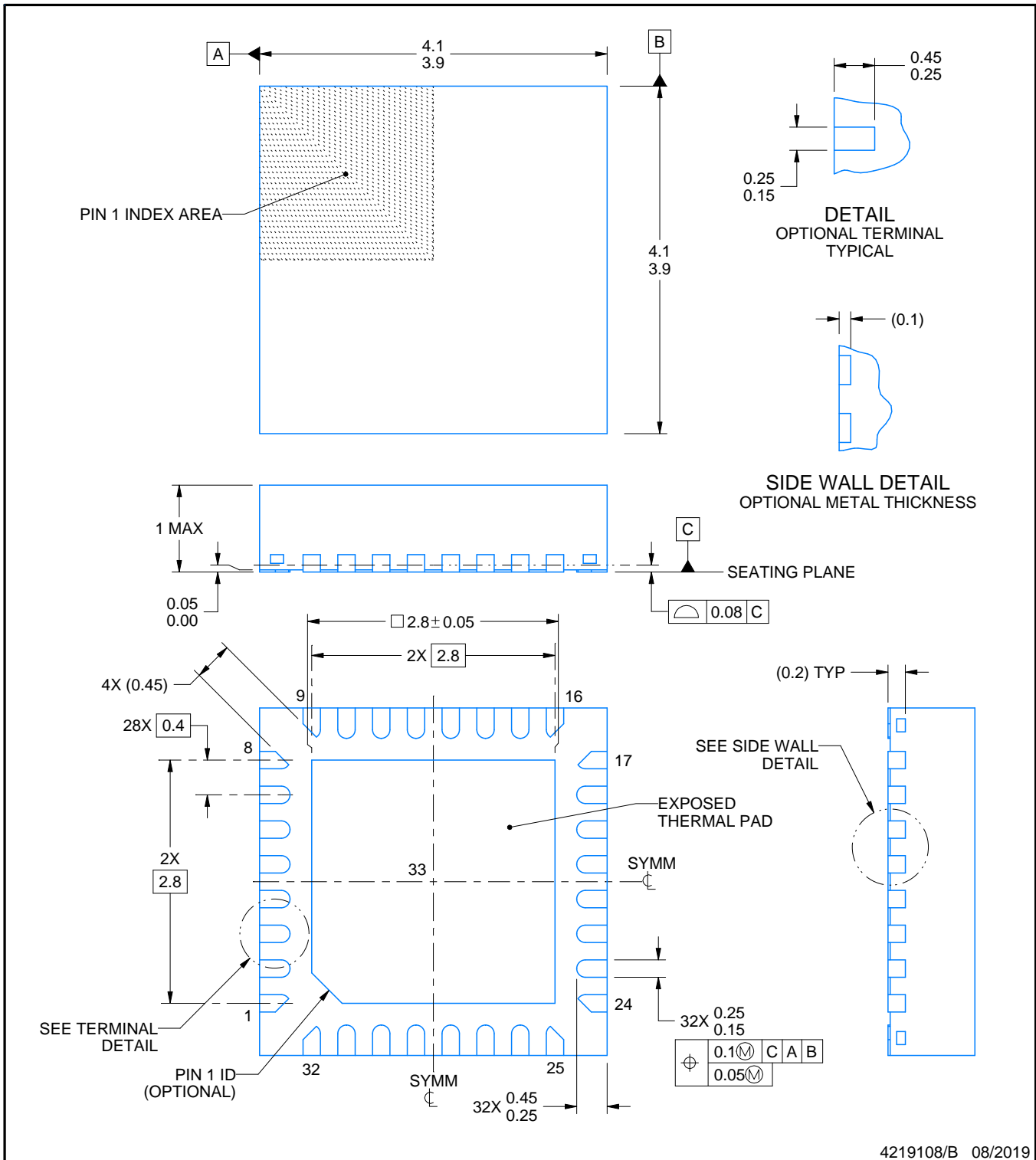

4219108/B 08/2019

NOTES:

1. All linear dimensions are in millimeters. Any dimensions in parenthesis are for reference only. Dimensioning and tolerancing per ASME Y14.5M.
2. This drawing is subject to change without notice.
3. The package thermal pad must be soldered to the printed circuit board for thermal and mechanical performance.

EXAMPLE BOARD LAYOUT

RSM0032B

VQFN - 1 mm max height

PLASTIC QUAD FLATPACK - NO LEAD

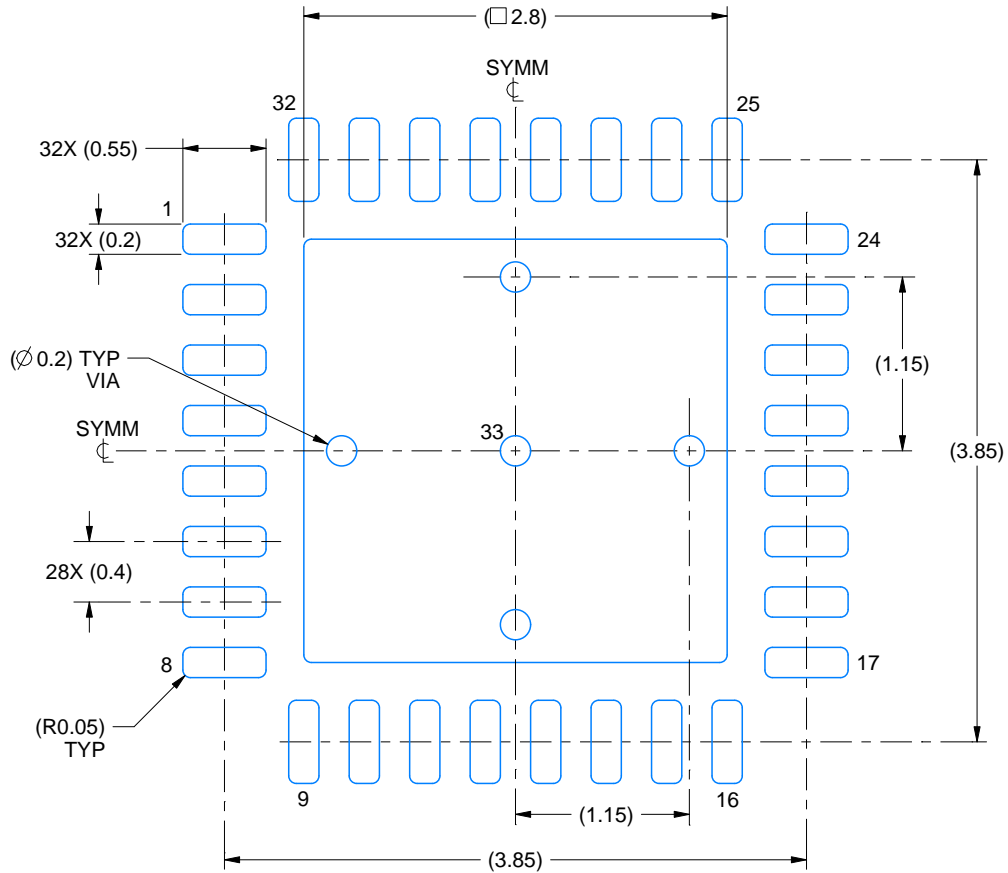

LAND PATTERN EXAMPLE
EXPOSED METAL SHOWN
SCALE:20X

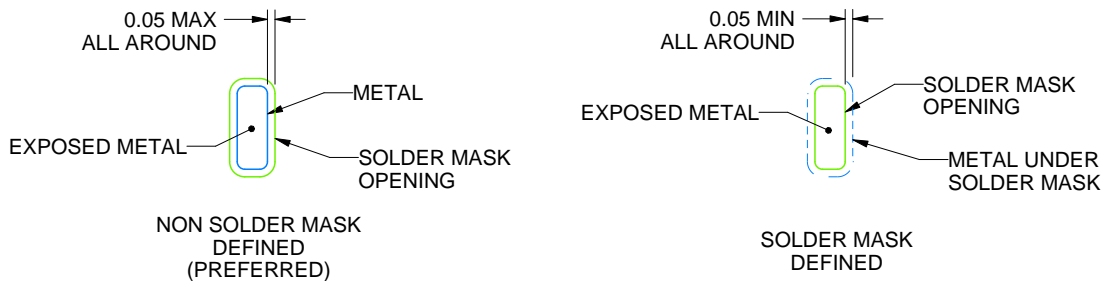

SOLDER MASK DETAILS

4219108/B 08/2019

NOTES: (continued)

4. This package is designed to be soldered to a thermal pad on the board. For more information, see Texas Instruments literature number SLUA271 (www.ti.com/lit/slue271).
5. Vias are optional depending on application, refer to device data sheet. If any vias are implemented, refer to their locations shown on this view. It is recommended that vias under paste be filled, plugged or tented.

IMPORTANT NOTICE AND DISCLAIMER

TI PROVIDES TECHNICAL AND RELIABILITY DATA (INCLUDING DATA SHEETS), DESIGN RESOURCES (INCLUDING REFERENCE DESIGNS), APPLICATION OR OTHER DESIGN ADVICE, WEB TOOLS, SAFETY INFORMATION, AND OTHER RESOURCES "AS IS" AND WITH ALL FAULTS, AND DISCLAIMS ALL WARRANTIES, EXPRESS AND IMPLIED, INCLUDING WITHOUT LIMITATION ANY IMPLIED WARRANTIES OF MERCHANTABILITY, FITNESS FOR A PARTICULAR PURPOSE OR NON-INFRINGEMENT OF THIRD PARTY INTELLECTUAL PROPERTY RIGHTS.

These resources are intended for skilled developers designing with TI products. You are solely responsible for (1) selecting the appropriate TI products for your application, (2) designing, validating and testing your application, and (3) ensuring your application meets applicable standards, and any other safety, security, regulatory or other requirements.

These resources are subject to change without notice. TI grants you permission to use these resources only for development of an application that uses the TI products described in the resource. Other reproduction and display of these resources is prohibited. No license is granted to any other TI intellectual property right or to any third party intellectual property right. TI disclaims responsibility for, and you will fully indemnify TI and its representatives against, any claims, damages, costs, losses, and liabilities arising out of your use of these resources.



TI's products are provided subject to [TI's Terms of Sale](#) or other applicable terms available either on ti.com or provided in conjunction with such TI products. TI's provision of these resources does not expand or otherwise alter TI's applicable warranties or warranty disclaimers for TI products.

TI objects to and rejects any additional or different terms you may have proposed.

Mailing Address: Texas Instruments, Post Office Box 655303, Dallas, Texas 75265
Copyright © 2022, Texas Instruments Incorporated

Looking for pricing, stock, or lifecycle information?

Click below to explore more details on WIN SOURCE:

-  [View TRS3253EIRSMR](#) on WIN SOURCE
-  [Texas Instruments](#) Information

Optimize Your Supply Chain with WIN SOURCE Solutions

-  Global Sourcing Solution
-  Obsolete Management
-  Cost Control Management
-  Shortage Management
-  Alternative Solution
-  Excess Inventory Management