



**THE DATASHEET OF
TRS3221ECPWR**



TRIS3221E 3-V TO 5.5-V Single-Channel RS-232 Line Driver/Receiver with ± 15 -kV IEC ESD Protection In Small Package

1 Features

- ESD Protection for RS-232 Pins
 - ± 15 -kV Human-Body Model (HBM)
 - ± 8 kV (IEC 61000-4-2, contact discharge)
 - ± 15 kV (IEC 61000-4-2, air-gap discharge)
- Meets or exceeds the requirements of TIA/EIA-232-F and ITU v.28 standards
- Operates with 3-V to 5.5-V V_{CC} supply
- Operates up to 250 kbit/s
- One driver and one receiver
- Near chip-scale package, 16-pin VQFN (RGT, 82% smaller than TSSOP package)
- Low standby current: 1 μ A Typical
- External capacitors: $4 \times 0.1 \mu$ F
- Accepts 5-V logic input with 3.3-V supply
- Alternative high-speed pin-compatible device (1 Mbit/s)
 - TRSF3221E
- Auto-powerdown feature automatically disables drivers for power savings

2 Applications

- [Industrial PCs](#)
- [Wired networking](#)
- [Data center and enterprise computing](#)
- [Battery-powered systems](#)
- [PDAs](#)
- [Notebooks](#)
- [Laptops](#)
- [Palmtop PCs](#)
- [Hand-held equipment](#)

3 Description

The TRIS3221E is a single driver, single receiver RS-232 solution operating from a single V_{CC} supply. The RS-232 pins provide IEC G1000-4-2 ESD protection. The device meets the requirements of TIA/EIA-232-F and provides the electrical interface between an asynchronous communication controller and the serial-port connector. The charge pump and four small external capacitors allow operation from a single 3-V to 5.5-V supply. These devices operate at data signaling rates up to 250 kbit/s and a maximum of 30-V/ μ s driver output slew rate.

Flexible control options for power management are available when the serial port is inactive. The auto-powerdown feature functions when FORCEON is low and FORCEOFF is high. During this mode of operation, if the device does not sense a valid RS-232 signal on the receiver input, the driver output is disabled. If FORCEOFF is set low and \overline{EN} is high, both the driver and receiver are shut off, and the supply current is reduced to 1 μ A. Disconnecting the serial port or turning off the peripheral drivers causes the auto-powerdown condition to occur. Auto-powerdown can be disabled when FORCEON and FORCEOFF are high.

With auto-powerdown enabled, the device is activated automatically when a valid signal is applied to the receiver input. The $\overline{INVALID}$ output notifies the user if an RS-232 signal is present at the receiver input. $\overline{INVALID}$ is high (valid data) if the receiver input voltage is greater than 2.7 V or less than -2.7 V, or has been between -0.3 V and 0.3 V for less than 30 μ s. $\overline{INVALID}$ is low (invalid data) if the receiver input voltage is between -0.3 V and 0.3 V for more than 30 μ s. Refer to [Figure 7-5](#) for receiver input levels.

Device Information

PART NUMBER	PACKAGE ⁽¹⁾	BODY SIZE (NOM)
TRIS3221E	SSOP (DB) (16)	6.20 mm x 5.30 mm
	TSSOP (PW) (16)	5.00 mm x 4.40 mm
	VQFN (RGT) (16)	3.00 mm x 3.00 mm

(1) For all available packages, see the orderable addendum at the end of the data sheet.

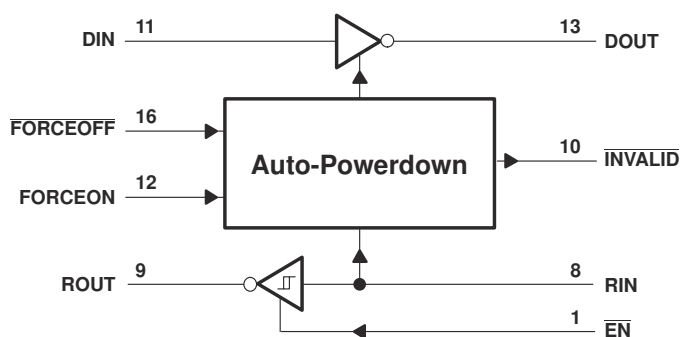

Simplified Schematic



Table of Contents

1 Features	1	8 Detailed Description	13
2 Applications	1	8.1 Overview.....	13
3 Description	1	8.2 Functional Block Diagram.....	13
4 Revision History	2	8.3 Feature Description.....	13
5 Pin Configuration and Functions	3	8.4 Device Functional Modes.....	14
6 Specifications	4	9 Application Information Disclaimer	15
6.1 Absolute Maximum Ratings.....	4	9.1 Application Information.....	15
6.2 ESD Ratings.....	4	9.2 Typical Application.....	15
6.3 ESD Ratings, IEC Specifications.....	4	9.3 Design Requirements.....	16
6.4 Recommended Operating Conditions.....	5	9.4 Detailed Design Procedure.....	16
6.5 Thermal Information.....	5	9.5 Application Curve.....	16
6.6 Electrical Characteristics.....	5	10 Layout	17
6.7 Driver Section Electrical Characteristics.....	6	10.1 Layout Guidelines.....	17
6.8 Driver Section Switching Characteristics.....	6	10.2 Layout Example.....	17
6.9 Receiver Section Electrical Characteristics.....	7	11 Device and Documentation Support	18
6.10 Receiver Section Switching Characteristics.....	7	11.1 Receiving Notification of Documentation Updates..	18
6.11 Auto-Powerdown Section Electrical Characteristics.....	8	11.2 Support Resources.....	18
6.12 Auto-Powerdown Section Switching Characteristics.....	8	11.3 Trademarks.....	18
6.13 Typical Characteristics.....	9	11.4 Electrostatic Discharge Caution.....	18
7 Parameter Measurement Information	10	11.5 Glossary.....	18
		12 Mechanical, Packaging, and Orderable Information	19

4 Revision History

NOTE: Page numbers for previous revisions may differ from page numbers in the current version.

Changes from Revision A (December 2020) to Revision B (July 2021)	Page
• Changed the <i>Applications</i> list.....	1
• Changed the table note for the <i>ESD Ratings, IEC Specifications</i> to make it applicable to all packages.....	4
• Changed the thermal information for PW and DB packages.....	5

Changes from Revision * (June 2007) to Revision A (December 2020)	Page
• Added <i>ESD Ratings, ESD Ratings, IEC Specifications</i> tables, <i>Thermal Information</i> table, <i>Typical Characteristics</i> section, <i>Detailed Description</i> section, <i>Application and Implementation</i> section, <i>Power Supply Recommendations</i> section, <i>Layout</i> section, <i>Device and Documentation Support</i> section, and <i>Mechanical, Packaging, and Orderable Information</i> section.....	1
• Deleted <i>Ordering Information</i> table.....	1
• Added the RGT (VQFN-16) package pinout	3
• Added data rate and $t_{sk(p)}$ rows for the RGT package in <i>Driver Section Switching Characteristics</i> table	6
• Added t_{pLH} , t_{pHL} , $t_{sk(p)}$ rows for the RGT package in <i>Receiver Section Switching Characteristics</i> table	7

5 Pin Configuration and Functions

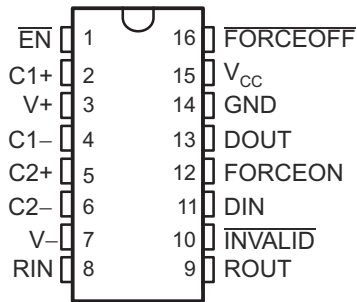

Figure 5-1. 16-Pin SSOP (DB) or TSSOP (PW) Packages, Top View

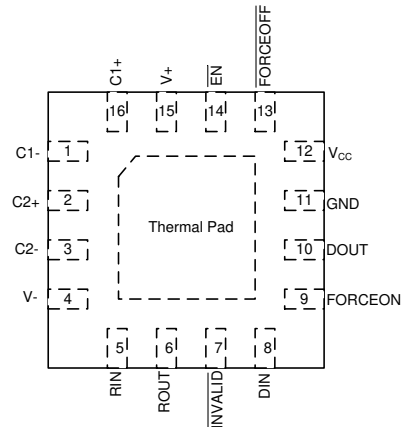

Figure 5-2. 16-pin VQFN (RGT) Package, Top View

Table 5-1. Pin Functions

NAME	PIN		TYPE	DESCRIPTION
	DB or PW	RGT		
C1+	2	16	—	Positive terminals of the voltage-doubler charge-pump capacitors
C2+	5	2	—	
C1-	4	1	—	Negative terminals of the voltage-doubler charge-pump capacitors
C2-	6	3	—	
DIN	11	8	I	Driver input
DOUT	13	10	O	RS-232 driver output
EN	1	14	I	Low input enables receiver ROUT output. High input sets ROUT to high impedance.
FORCEOFF	16	13	I	Automatic power-down control input
FORCEON	12	9	I	Automatic power-down control input
GND	14	11	GND	Ground
INVALID	10	7	O	Invalid output pin. Output is low when all RIN inputs are unpowered.
RIN	8	5	I	RS-232 receiver input
ROUT	9	6	O	Receiver output
V _{CC}	15	12	—	3-V to 5.5-V supply voltage
V+	3	15	O	5.5-V supply generated by the charge pump
V-	7	4	O	-5.5-V supply generated by the charge pump
Thermal Pad	None	Thermal Pad	-	Exposed thermal pad. Can be connected to GND or left floating.

6 Specifications

6.1 Absolute Maximum Ratings

over operating free-air temperature range (unless otherwise noted) ⁽¹⁾

		MIN	MAX	UNIT
V _{CC}	Supply voltage range ⁽²⁾	-0.3	6	V
V+	Positive output supply voltage range ⁽²⁾	-0.3	7	V
V-	Negative output supply voltage range ⁽²⁾	0.3	-7	V
V+ - V-	Supply voltage difference ⁽²⁾		13	V
V _I	Input voltage range	DIN, FORCEOFF, FORCEON, EN		V
		RIN		
V _O	Output voltage range	DOUT		V
		ROUT, INVALID		
T _J	Operating virtual junction temperature		150	°C
T _{stg}	Storage temperature range	-65	150	°C

- (1) Stresses beyond those listed under "absolute maximum ratings" may cause permanent damage to the device. These are stress ratings only, and functional operation of the device at these or any other conditions beyond those indicated under "recommended operating conditions" is not implied. Exposure to absolute-maximum-rated conditions for extended periods may affect device reliability.
- (2) All voltages are with respect to network GND.

6.2 ESD Ratings

			VALUE	UNIT
V _(ESD)	Electrostatic discharge	Human-body model (HBM), per ANSI/ESDA/JEDEC JS-001 ⁽¹⁾	±3000	V
			±15000	
		Charged-device model (CDM), per JEDEC specification JESD22-C101 ⁽²⁾	±1500	

- (1) JEDEC document JEP155 states that 500-V HBM allows safe manufacturing with a standard ESD control process.
- (2) JEDEC document JEP157 states that 250-V CDM allows safe manufacturing with a standard ESD control process.

6.3 ESD Ratings, IEC Specifications

NAME	TEST CONDITIONS	TYP	UNIT
R _{IN} , D _{OUT}	IEC 61000-4-2 Contact Discharge ⁽¹⁾	±8000	V
	IEC 61000-4-2 Air-Gap Discharge ⁽¹⁾	±15000	

- (1) A minimum of 1-μF capacitor is required between VCC and GND to meet the specified IEC ESD level

6.4 Recommended Operating Conditions

See [Figure 9-1](#), and note ⁽¹⁾

			MIN	NOM	MAX	UNIT
Supply voltage		V _{CC} = 3.3 V	3	3.3	3.6	V
		V _{CC} = 5 V	4.5	5	5.5	
V _{IH}	Driver and control high-level input voltage	DIN, FORCEOFF, FORCEON, $\overline{\text{EN}}$	V _{CC} = 3.3 V			V
			V _{CC} = 5 V			
V _{IL}	Driver and control low-level input voltage	DIN, FORCEOFF, FORCEON, $\overline{\text{EN}}$				0.8
V _I	Driver and control input voltage	DIN, FORCEOFF, FORCEON	0			5.5
V _I	Receiver input voltage		-25			25
T _A	Operating free-air temperature	TRS3221EC	0			70
		TRS3221EI	-40			85

(1) Test conditions are C1–C4 = 0.1 μF at V_{CC} = 3.3 V ± 0.3 V; C1 = 0.047 μF, C2–C4 = 0.33 μF at V_{CC} = 5 V ± 0.5 V.

6.5 Thermal Information

THERMAL METRIC ⁽¹⁾	TRS3221E			UNIT	
	DB (SSOP)	PW (TSSOP)	RGT (VQFN)		
	16 PINS	16 PINS	16 PINS		
R _{θJA}	Junction-to-ambient thermal resistance	105.8	110.9	52.1	°C/W
R _{θJC(top)}	Junction-to-case (top) thermal resistance	51.9	41.7	60.6	°C/W
R _{θJB}	Junction-to-board thermal resistance	57.6	57.2	26.8	°C/W
ψ _{JT}	Junction-to-top characterization parameter	14.1	4.2	2.5	°C/W
ψ _{JB}	Junction-to-board characterization parameter	56.8	56.6	26.8	°C/W
R _{θJC(bot)}	Junction-to-case (bottom) thermal resistance	N/A	N/A	12.0	°C/W

(1) For more information about traditional and new thermal metrics, see the *Semiconductor and IC Package Thermal Metrics* application report, [SPRA953](#).

6.6 Electrical Characteristics

over recommended ranges of supply voltage and operating free-air temperature (unless otherwise noted) (see [Figure 9-1](#))

PARAMETER		TEST CONDITIONS ⁽²⁾		MIN	TYP ⁽¹⁾	MAX	UNIT
I _I	Input leakage current	FORCEOFF, FORCEON, $\overline{\text{EN}}$			±0.01	±1	μA
I _{CC}	Supply current	Auto-powerdown disabled	No load, FORCEOFF and FORCEON at V _{CC}		0.3	1	mA
		Powered off	V _{CC} = 3.3 V or 5 V, T _A = 25°C		1	10	μA
		Auto-powerdown enabled	No load, FORCEOFF at V _{CC} , FORCEON at GND, All RIN are open or grounded		1	10	

(1) All typical values are at V_{CC} = 3.3 V or V_{CC} = 5 V, and T_A = 25°C.

(2) Test conditions are C1–C4 = 0.1 μF at V_{CC} = 3.3 V ± 0.3 V; C1 = 0.047 μF, C2–C4 = 0.33 μF at V_{CC} = 5 V ± 0.5 V.

6.7 Driver Section Electrical Characteristics

over recommended ranges of supply voltage and operating free-air temperature (unless otherwise noted) (see [Figure 9-1](#))

PARAMETER	TEST CONDITIONS ⁽³⁾			MIN	TYP ⁽¹⁾	MAX	UNIT
V _{OH} High-level output voltage	DOUT at R _L = 3 kΩ to GND, DIN = GND			5	5.4		V
V _{OL} Low-level output voltage	DOUT at R _L = 3 kΩ to GND, DIN = V _{CC}			-5	-5.4		V
I _{IH} High-level input current	V _I = V _{CC}				±0.01	±1	μA
I _{IL} Low-level input current	V _I = GND				±0.01	±1	μA
I _{OS} Short-circuit output current ⁽²⁾	V _{CC} = 3.6 V, V _O = 0 V				±35	±60	mA
	V _{CC} = 5.5 V, V _O = 0 V				±35	±60	
r _o Output resistance	V _{CC} , V+, and V- = 0 V, V _O = ±2 V			300	10M		Ω
I _{off} Output leakage current	FORCEOFF = GND	V _O = ±12 V, V _{CC} = 3 V to 3.6 V				±25	μA
		V _O = ±10 V, V _{CC} = 4.5 V to 5.5 V				±25	

(1) All typical values are at V_{CC} = 3.3 V or V_{CC} = 5 V, and T_A = 25°C.

(2) Short-circuit durations should be controlled to prevent exceeding the device absolute power-dissipation ratings, and not more than one output should be shorted at a time.

(3) Test conditions are C1–C4 = 0.1 μF at V_{CC} = 3.3 V ± 0.3 V; C1 = 0.047 μF, C2–C4 = 0.33 μF at V_{CC} = 5 V ± 0.5 V.

6.8 Driver Section Switching Characteristics

over recommended ranges of supply voltage and operating free-air temperature (unless otherwise noted) (see [Figure 9-1](#))

PARAMETER	TEST CONDITIONS ⁽³⁾			MIN	TYP ⁽¹⁾	MAX	UNIT
Maximum data rate	C _L = 1000 pF, R _L = 3 kΩ, See Figure 7-1	RGT package		250	500		kbit/s
		DB or PW package		150	250		
t _{sk(p)} Pulse skew ⁽²⁾	C _L = 1000 pF, R _L = 3 kΩ Figure 7-2	RGT package			50		ns
		DB or PW package			100		
SR(tr) Slew rate, transition region (see Figure 7-1)	V _{CC} = 3.3 V, R _L = 3 kΩ to 7 kΩ	C _L = 150 pF to 1000 pF		6		30	V/μs
		C _L = 150 pF to 2500 pF		4		30	

(1) All typical values are at V_{CC} = 3.3 V or V_{CC} = 5 V, and T_A = 25°C.

(2) Pulse skew is defined as |t_{PLH} - t_{PHL}| of each channel of the same device.

(3) Test conditions are C1–C4 = 0.1 μF at V_{CC} = 3.3 V ± 0.3 V; C1 = 0.047 μF, C2–C4 = 0.33 μF at V_{CC} = 5 V ± 0.5 V.

6.9 Receiver Section Electrical Characteristics

over recommended ranges of supply voltage and operating free-air temperature (unless otherwise noted) (see [Figure 9-1](#))

PARAMETER		TEST CONDITIONS ⁽²⁾	MIN	TYP ⁽¹⁾	MAX	UNIT
V _{OH}	High-level output voltage	I _{OH} = -1 mA	V _{CC} - 0.6	V _{CC} - 0.1		V
V _{OL}	Low-level output voltage	I _{OL} = 1.6 mA			0.4	V
V _{IT+}	Positive-going input threshold voltage	V _{CC} = 3.3 V		1.6	2.4	V
		V _{CC} = 5 V		1.9	2.4	
V _{IT-}	Negative-going input threshold voltage	V _{CC} = 3.3 V	0.6	1.1		V
		V _{CC} = 5 V	0.8	1.4		
V _{hys}	Input hysteresis (V _{IT+} - V _{IT-})			0.5		V
I _{off}	Output leakage current	$\overline{EN} = V_{CC}$		±0.05	±10	µA
r _i	Input resistance	V _I = ±3 V to ±25 V	3	5	7	kΩ

(1) All typical values are at V_{CC} = 3.3 V or V_{CC} = 5 V, and T_A = 25°C.

(2) Test conditions are C1–C4 = 0.1 µF at V_{CC} = 3.3 V ± 0.3 V; C1 = 0.047 µF, C2–C4 = 0.33 µF at V_{CC} = 5 V ± 0.5 V.

6.10 Receiver Section Switching Characteristics

over recommended ranges of supply voltage and operating free-air temperature (unless otherwise noted) (see [Figure 9-1](#))

PARAMETER		TEST CONDITIONS ⁽³⁾		TYP ⁽¹⁾	UNIT
t _{PLH}	Propagation delay time, low- to high-level output	C _L = 150 pF, See Figure 7-3	RGT package	100	ns
			DB or PW package	150	
t _{PHL}	Propagation delay time, high- to low-level output	C _L = 150 pF, See Figure 7-3	RGT package	125	ns
			DB or PW package	150	
t _{en}	Output enable time	C _L = 150 pF, R _L = 3 kΩ, See Figure 7-4		200	ns
t _{dis}	Output disable time	C _L = 150 pF, R _L = 3 kΩ, See Figure 7-4		200	ns
t _{sk(p)}	Pulse skew ⁽²⁾	See Figure 7-3	RGT package	25	ns
			DB or PW package	50	

(1) All typical values are at V_{CC} = 3.3 V or V_{CC} = 5 V, and T_A = 25°C.

(2) Pulse skew is defined as |t_{PLH} - t_{PHL}| of each channel of the same device.

(3) Test conditions are C1–C4 = 0.1 µF at V_{CC} = 3.3 V ± 0.3 V; C1 = 0.047 µF, C2–C4 = 0.33 µF at V_{CC} = 5 V ± 0.5 V.

6.11 Auto-Powerdown Section Electrical Characteristics

over recommended ranges of supply voltage and operating free-air temperature (unless otherwise noted) (see [Figure 7-5](#))

PARAMETER		TEST CONDITIONS	MIN	MAX	UNIT
$V_{T+(valid)}$	Receiver input threshold for INVALID high-level output voltage	FORCEON = GND, $\overline{FORCEOFF} = V_{CC}$		2.7	V
$V_{T-(valid)}$	Receiver input threshold for INVALID high-level output voltage	FORCEON = GND, $\overline{FORCEOFF} = V_{CC}$	-2.7		V
$V_{T(invalid)}$	Receiver input threshold for INVALID low-level output voltage	FORCEON = GND, $\overline{FORCEOFF} = V_{CC}$	-0.3	0.3	V
V_{OH}	$\overline{INVALID}$ high-level output voltage	$I_{OH} = -1\text{ mA}$, FORCEON = GND, $\overline{FORCEOFF} = V_{CC}$	$V_{CC} - 0.6$		V
V_{OL}	$\overline{INVALID}$ low-level output voltage	$I_{OL} = 1.6\text{ mA}$, FORCEON = GND, $\overline{FORCEOFF} = V_{CC}$		0.4	V

6.12 Auto-Powerdown Section Switching Characteristics

over recommended ranges of supply voltage and operating free-air temperature (unless otherwise noted) (see [Figure 7-5](#))

PARAMETER		TYP ⁽¹⁾	UNIT
t_{valid}	Propagation delay time, low- to high-level output	1	μs
$t_{invalid}$	Propagation delay time, high- to low-level output	30	μs
t_{en}	Supply enable time	100	μs

(1) All typical values are at $V_{CC} = 3.3\text{ V}$ or $V_{CC} = 5\text{ V}$, and $T_A = 25^\circ\text{C}$.

6.13 Typical Characteristics

$V_{CC} = 3.3\text{ V}$ and $T_A = 25\text{ }^\circ\text{C}$ unless specified otherwise.

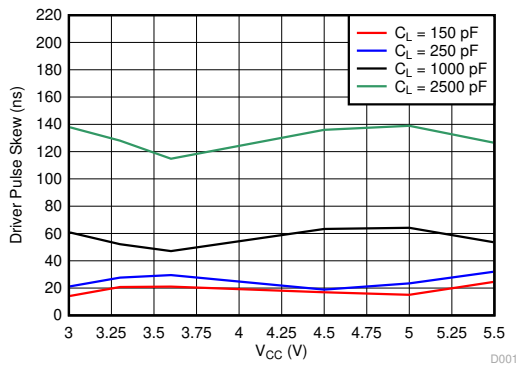

Figure 6-1. Driver Pulse Skew vs Load Capacitance and Supply Voltage at $T_A = 25\text{ }^\circ\text{C}$ (RGT Package)

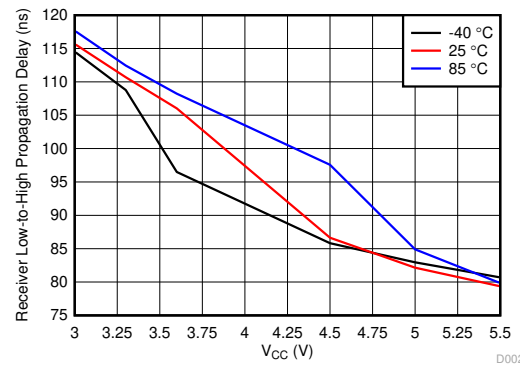

Figure 6-2. Receiver Path Low-to-High Propagation Delay vs T_A and Supply Voltage (RGT Package)

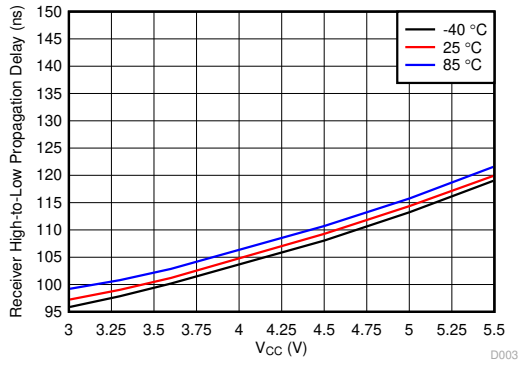

Figure 6-3. Receiver Path High-to-Low Propagation Delay vs T_A and Supply Voltage (RGT Package)

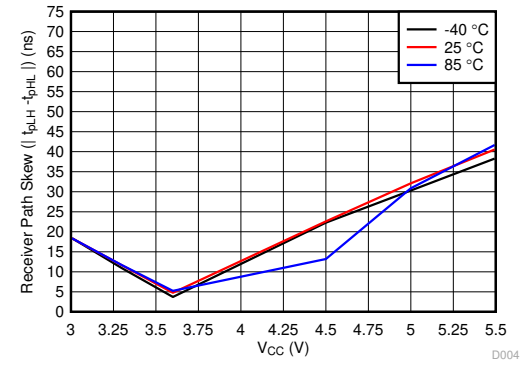
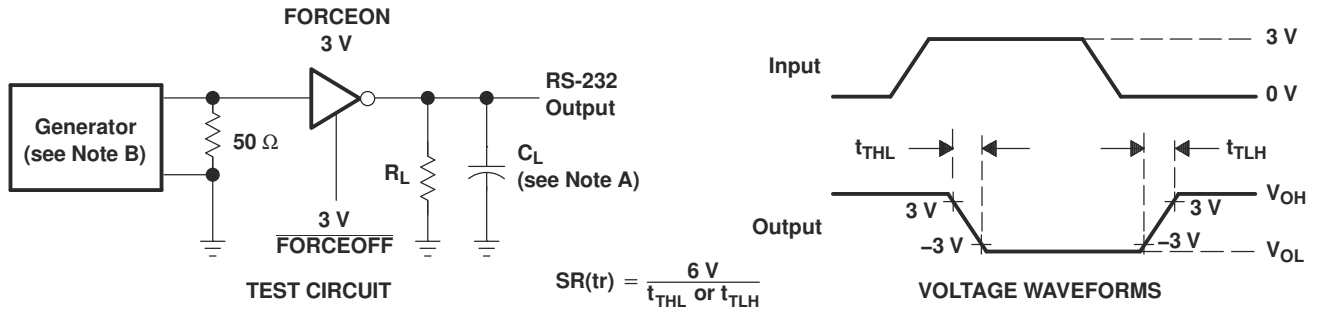

Figure 6-4. Receiver Pulse Skew ($|t_{pLH} - t_{pHL}|$) vs T_A and Supply Voltage (RGT Package)

7 Parameter Measurement Information



- NOTES: A. C_L includes probe and jig capacitance.
 B. The pulse generator has the following characteristics: PRR = 250 kbit/s, $Z_0 = 50 \Omega$, 50% duty cycle, $t_r \leq 10$ ns, $t_f \leq 10$ ns.

Figure 7-1. Driver Slew Rate

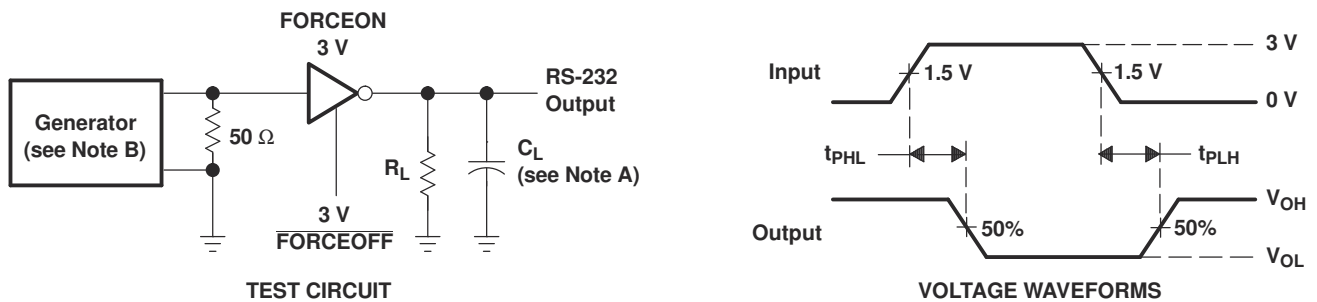

- NOTES: A. C_L includes probe and jig capacitance.
 B. The pulse generator has the following characteristics: PRR = 250 kbit/s, $Z_0 = 50 \Omega$, 50% duty cycle, $t_r \leq 10$ ns, $t_f \leq 10$ ns.

Figure 7-2. Driver Pulse Skew

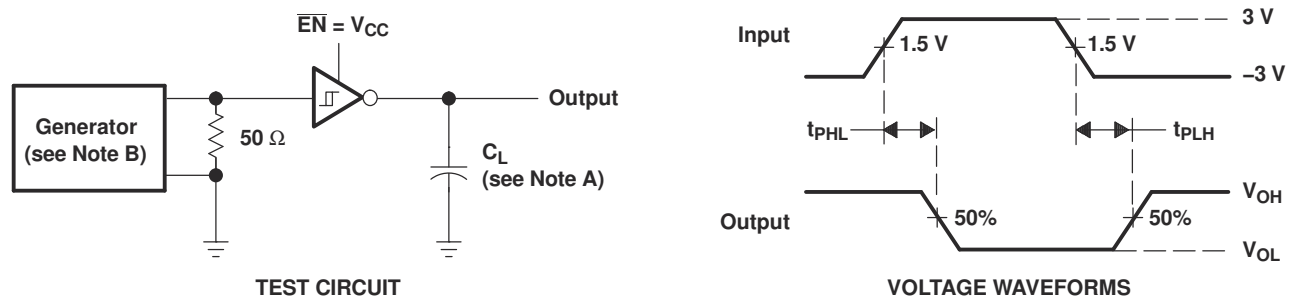

- NOTES: A. C_L includes probe and jig capacitance.
 B. The pulse generator has the following characteristics: $Z_0 = 50 \Omega$, 50% duty cycle, $t_r \leq 10$ ns, $t_f \leq 10$ ns.

Figure 7-3. Receiver Propagation Delay Times

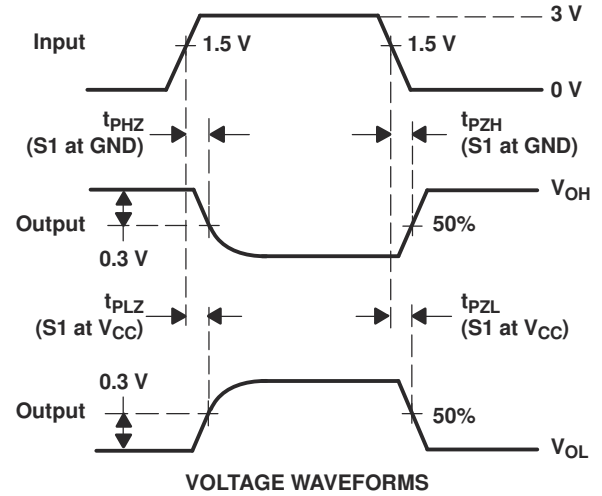
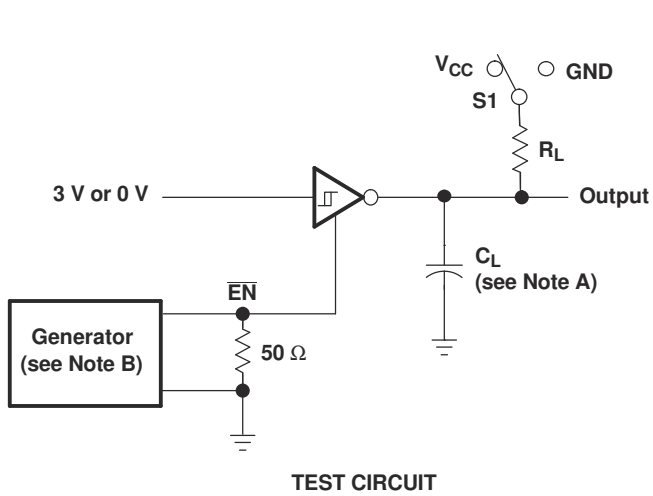

- NOTES:
- A. C_L includes probe and jig capacitance.
 - B. The pulse generator has the following characteristics: $Z_O = 50 \Omega$, 50% duty cycle, $t_r \leq 10 \text{ ns}$, $t_f \leq 10 \text{ ns}$.
 - C. t_{PLZ} and t_{PHZ} are the same as t_{dis} .
 - D. t_{PZL} and t_{PZH} are the same as t_{en} .

Figure 7-4. Receiver Enable and Disable Times

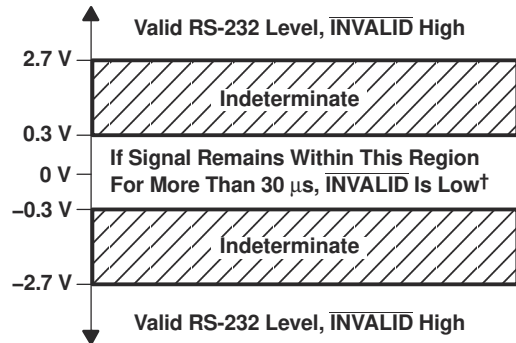
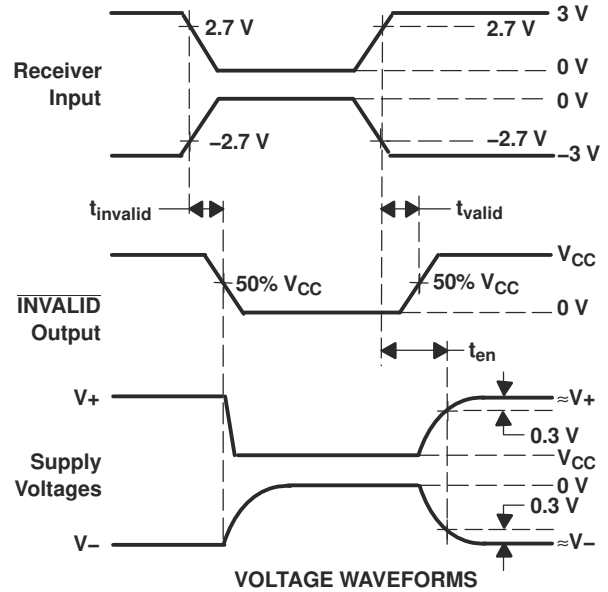
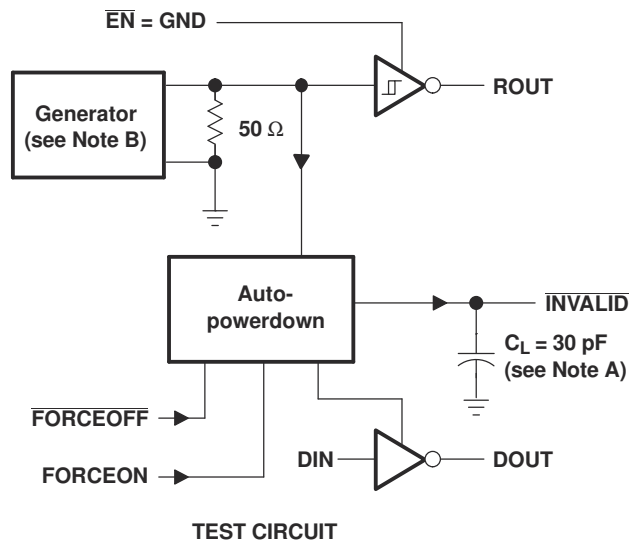

† Auto-powerdown disables drivers and reduces supply current to 1 μA.

NOTES: A. C_L includes probe and jig capacitance.

B. The pulse generator has the following characteristics: PRR = 5 kbit/s, $Z_O = 50 \Omega$, 50% duty cycle, $t_r \leq 10 \text{ ns}$, $t_f \leq 10 \text{ ns}$.

Figure 7-5. $\overline{\text{INVALID}}$ Propagation Delay Times and Driver Enabling Time

8 Detailed Description

8.1 Overview

The TRS3221E device is a one-driver and one-receiver RS-232 interface device. The RS-232 input and output are protected up to ± 15 kV using the Human-Body Model. The charge pump requires only four small 0.1- μ F capacitors for operation from a 3.3-V supply. The TRS3221E device is capable of running at data rates up to 250 kbps while maintaining RS-232-compliant output levels.

Automatic power down can be disabled when $\overline{\text{FORCEON}}$ and $\overline{\text{FORCEOFF}}$ are high. With automatic power down plus enabled, the device activates automatically when a valid signal is applied to any receiver input. The device can automatically power down the driver to save power when the RIN input is unpowered.

$\overline{\text{INVALID}}$ is high (valid data) if receiver input voltage is greater than 2.7 V or less than -2.7 V, or has been between -0.3 V and 0.3 V for less than 30 μ s. $\overline{\text{INVALID}}$ is low (invalid data) if receiver input voltages are between -0.3 V and 0.3 V for more than 30 μ s. Refer to [Figure 7-5](#) for receiver input levels.

8.2 Functional Block Diagram

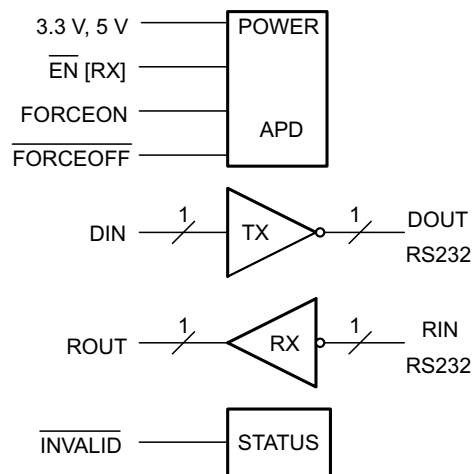

8.3 Feature Description

8.3.1 Power

The power block increases, inverts, and regulates voltage at V+ and V– pins using a charge pump that requires four external capacitors. The automatic power-down feature for the driver is controlled by $\overline{\text{FORCEON}}$ and $\overline{\text{FORCEOFF}}$ inputs. The receiver is controlled by the $\overline{\text{EN}}$ input (see [Table 8-1](#) and [Table 8-2](#)).

When the device is unpowered, it can be safely connected to an active remote RS232 device.

8.3.2 RS232 Driver

One driver interfaces standard logic level to RS232 levels. DIN input must be valid high or low.

8.3.3 RS232 Receiver

One receiver interfaces RS232 levels to standard logic levels. An open input results in a high output on ROUT. RIN input includes an internal standard RS232 load. A logic high input on the $\overline{\text{EN}}$ pin shuts down the receiver output.

8.3.4 RS232 Status

The $\overline{\text{INVALID}}$ output goes low when RIN input is unpowered for more than 30 μ s. The $\overline{\text{INVALID}}$ output goes high when the receiver has a valid input. The $\overline{\text{INVALID}}$ output is active when V_{CC} is powered regardless of $\overline{\text{FORCEON}}$ and $\overline{\text{FORCEOFF}}$ inputs (see [Table 8-3](#)).

8.4 Device Functional Modes

Table 8-1. Driver

INPUTS ⁽¹⁾				OUTPUT	DRIVER STATUS
DIN	FORCEON	FORCEOFF	VALID RIN RS-232 LEVEL	DOUT	
X	X	L	X	Z	Powered off
L	H	H	X	H	Normal operation with automatic power down disabled
H	H	H	X	L	
L	L	H	Yes	H	Normal operation with automatic power down enabled
H	L	H	Yes	L	
L	L	H	No	Z	Powered off by automatic power-down feature
H	L	H	No	Z	

(1) H = high level, L = low level, X = irrelevant, Z = high impedance, Yes = |RIN| > 2.7 V, No = |RIN| < 0.3 V

Table 8-2. Receiver

INPUTS ⁽¹⁾			OUTPUT	RECEIVER STATUS
RIN	EN	VALID RIN RS-232 LEVEL	ROUT	
X	H	X	Z	Output off
L	L	X	H	Normal operation
H	L	X	L	
Open	L	No	H	

(1) H = high level, L = low level, X = irrelevant, Z = high impedance (off), Open = input disconnected or connected driver off

Table 8-3. INVALID

INPUTS ⁽¹⁾				OUTPUT
RIN	FORCEON	FORCEOFF	EN	INVALID
L	X	X	X	H
H	X	X	X	H
Open	X	X	X	L

(1) H = high level, L = low level, X = irrelevant, Z = high impedance (off), Open = input disconnected or connected driver off

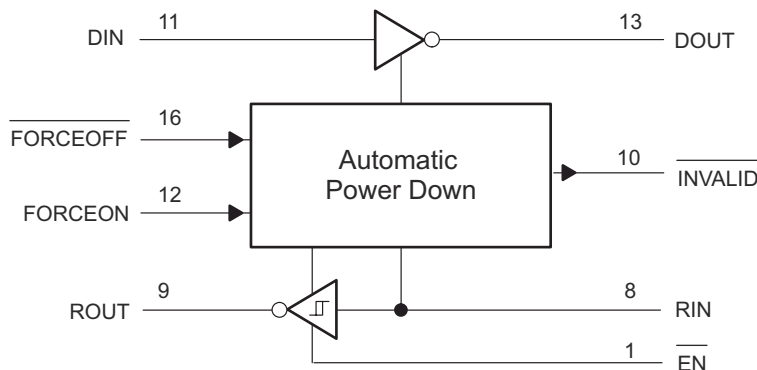

Figure 8-1. Logic Diagram

9 Application Information Disclaimer

Note

Information in the following applications sections is not part of the TI component specification, and TI does not warrant its accuracy or completeness. TI's customers are responsible for determining suitability of components for their purposes, as well as validating and testing their design implementation to confirm system functionality.

9.1 Application Information

The TRS3221E device is designed to convert single-ended signals into RS232-compatible signals, and RS232-compatible signals into single-ended signals.

This device can be used in any application where an RS232 line driver or receiver is required. One benefit of this device is its ESD protection, which helps protect other components on the board when the RS232 lines are tied to a physical connector

9.2 Typical Application

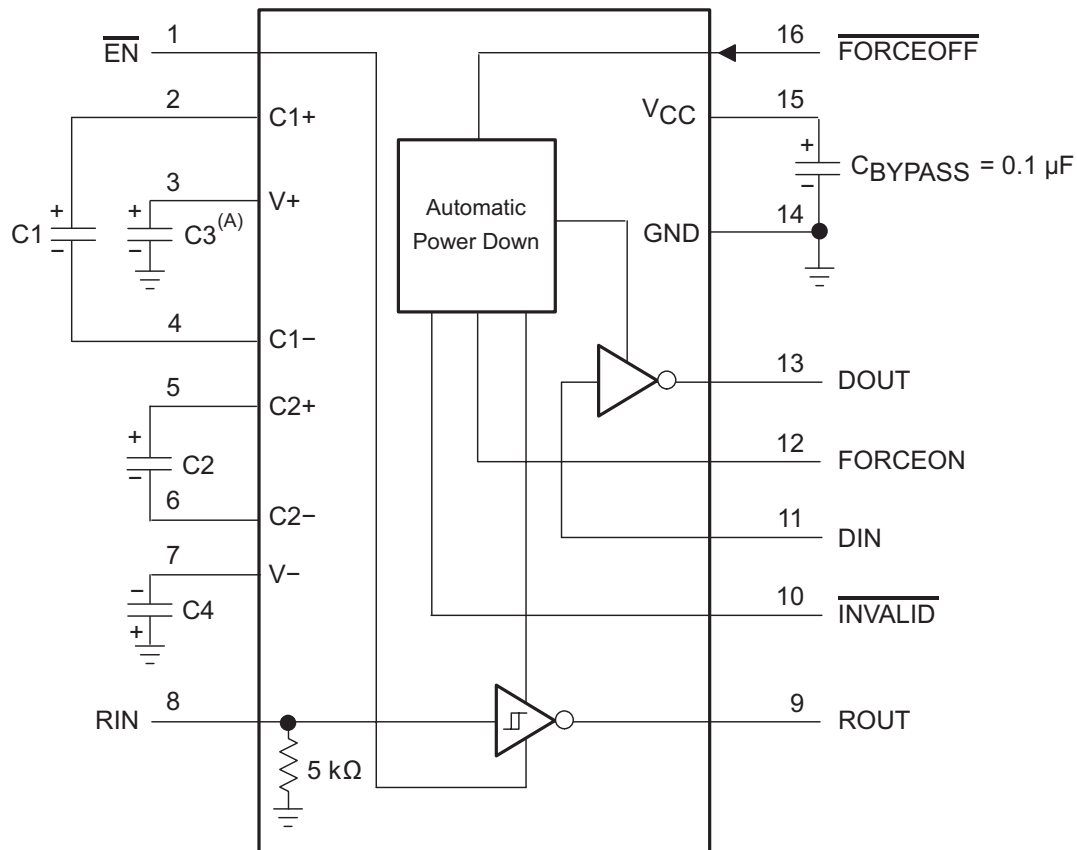

- A. C3 can be connected to V_{CC} or GND.
- B. Resistor values shown are nominal.
- C. Nonpolarized ceramic capacitors are acceptable. If polarized tantalum or electrolytic capacitors are used, they must be connected as shown.
- D. See [Table 9-1](#) for capacitor values.

Figure 9-1. Typical Operating Circuit and Capacitor Values

9.3 Design Requirements

- Recommended V_{CC} is 3.3 V or 5 V
 - 3 V to 5.5 V is also possible
 - Maximum recommended bit rate is 250 kbps
 - Use capacitors as shown in [Figure 9-1](#) and [Table 9-1](#)

Table 9-1. V_{CC} versus Capacitor Values

V_{CC}	C1	C2, C3, and C4
3.3 V \pm 0.3 V	0.1 μ F	0.1 μ F
5 V \pm 0.5 V	0.047 μ F	0.33 μ F
3 V to 5.5 V	0.1 μ F	0.47 μ F

9.4 Detailed Design Procedure

For proper operation, add capacitors as shown in [Figure 9-1](#) and [Table 9-1](#).

- DIN, $\overline{\text{FORCEOFF}}$ and FORCEON inputs must be connected to valid low or high logic levels
- Select capacitor values based on V_{CC} level for best performance

ROUT and DIN connect to UART or general purpose logic lines. FORCEON and $\overline{\text{FORCEOFF}}$ may be connected general purpose logic lines or tied to ground or V_{CC} . $\overline{\text{INVALID}}$ may be connected to a general purpose logic line or left unconnected. RIN and DOUT lines connect to a RS232 connector or cable. DIN, FORCEON, and $\overline{\text{FORCEOFF}}$ inputs must not be left unconnected.

9.5 Application Curve

V_{CC} of 3.3 V and 250 kbps alternative bit data stream

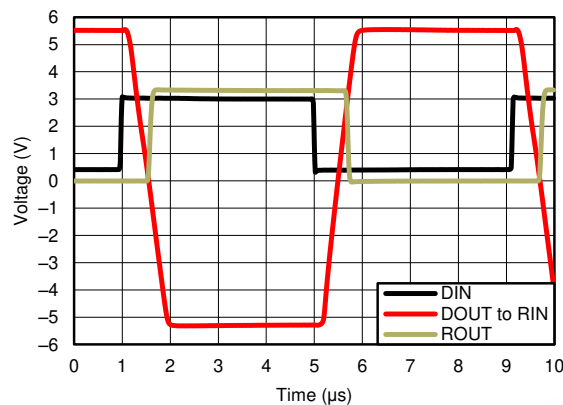

Figure 9-2. 250 kbps Driver to Receiver Loopback Timing Waveform, V_{CC} = 3.3 V

Power Supply Recommendations

V_{CC} must be between 3 V and 5.5 V. Charge pump capacitors must be chosen using [Table 9-1](#).

10 Layout

10.1 Layout Guidelines

Keep the external capacitor traces short. This is more important on C1 and C2 nodes, which have the fastest rise and fall times.

10.2 Layout Example

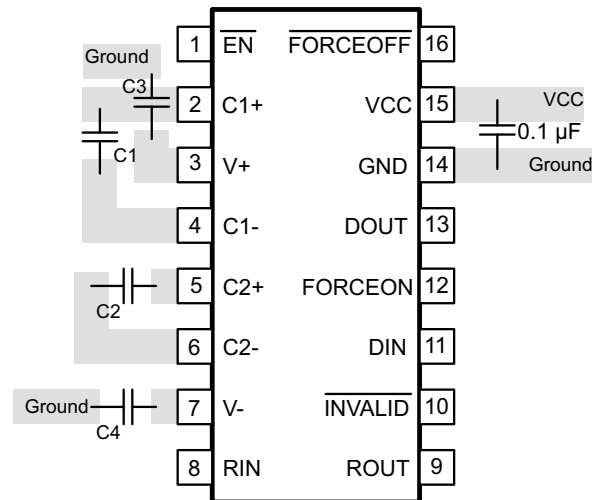

Figure 10-1. Layout Diagram

11 Device and Documentation Support

TI offers an extensive line of development tools. Tools and software to evaluate the performance of the device, generate code, and develop solutions are listed below.

11.1 Receiving Notification of Documentation Updates

To receive notification of documentation updates, navigate to the device product folder on ti.com. Click on *Subscribe to updates* to register and receive a weekly digest of any product information that has changed. For change details, review the revision history included in any revised document.

11.2 Support Resources

[TI E2E™ support forums](#) are an engineer's go-to source for fast, verified answers and design help — straight from the experts. Search existing answers or ask your own question to get the quick design help you need.

Linked content is provided "AS IS" by the respective contributors. They do not constitute TI specifications and do not necessarily reflect TI's views; see TI's [Terms of Use](#).

11.3 Trademarks

TI E2E™ is a trademark of Texas Instruments.

All trademarks are the property of their respective owners.

11.4 Electrostatic Discharge Caution



This integrated circuit can be damaged by ESD. Texas Instruments recommends that all integrated circuits be handled with appropriate precautions. Failure to observe proper handling and installation procedures can cause damage.

ESD damage can range from subtle performance degradation to complete device failure. Precision integrated circuits may be more susceptible to damage because very small parametric changes could cause the device not to meet its published specifications.

11.5 Glossary

[TI Glossary](#) This glossary lists and explains terms, acronyms, and definitions.

12 Mechanical, Packaging, and Orderable Information

The following pages include mechanical, packaging, and orderable information. This information is the most current data available for the designated devices. This data is subject to change without notice and revision of this document. For browser-based versions of this data sheet, refer to the left-hand navigation.

PACKAGING INFORMATION

Orderable Device	Status (1)	Package Type	Package Drawing	Pins	Package Qty	Eco Plan (2)	Lead finish/ Ball material (6)	MSL Peak Temp (3)	Op Temp (°C)	Device Marking (4/5)	Samples
TRS3221ECDBR	ACTIVE	SSOP	DB	16	2000	RoHS & Green	NIPDAU	Level-1-260C-UNLIM	0 to 70	RS21EC	Samples
TRS3221ECPWR	ACTIVE	TSSOP	PW	16	2000	RoHS & Green	NIPDAU	Level-1-260C-UNLIM	0 to 70	RS21EC	Samples
TRS3221EIDBR	ACTIVE	SSOP	DB	16	2000	RoHS & Green	NIPDAU	Level-1-260C-UNLIM	-40 to 85	RS21EI	Samples
TRS3221EIPWR	ACTIVE	TSSOP	PW	16	2000	RoHS & Green	NIPDAU	Level-1-260C-UNLIM	-40 to 85	RS21EI	Samples
TRS3221EIRGTR	ACTIVE	VQFN	RGT	16	3000	RoHS & Green	NIPDAU	Level-1-260C-UNLIM	-40 to 85	3221	Samples

(1) The marketing status values are defined as follows:

ACTIVE: Product device recommended for new designs.

LIFEBUY: TI has announced that the device will be discontinued, and a lifetime-buy period is in effect.

NRND: Not recommended for new designs. Device is in production to support existing customers, but TI does not recommend using this part in a new design.

PREVIEW: Device has been announced but is not in production. Samples may or may not be available.

OBSOLETE: TI has discontinued the production of the device.

(2) **RoHS:** TI defines "RoHS" to mean semiconductor products that are compliant with the current EU RoHS requirements for all 10 RoHS substances, including the requirement that RoHS substance do not exceed 0.1% by weight in homogeneous materials. Where designed to be soldered at high temperatures, "RoHS" products are suitable for use in specified lead-free processes. TI may reference these types of products as "Pb-Free".

RoHS Exempt: TI defines "RoHS Exempt" to mean products that contain lead but are compliant with EU RoHS pursuant to a specific EU RoHS exemption.

Green: TI defines "Green" to mean the content of Chlorine (Cl) and Bromine (Br) based flame retardants meet JS709B low halogen requirements of <=1000ppm threshold. Antimony trioxide based flame retardants must also meet the <=1000ppm threshold requirement.

(3) MSL, Peak Temp. - The Moisture Sensitivity Level rating according to the JEDEC industry standard classifications, and peak solder temperature.

(4) There may be additional marking, which relates to the logo, the lot trace code information, or the environmental category on the device.

(5) Multiple Device Markings will be inside parentheses. Only one Device Marking contained in parentheses and separated by a "~" will appear on a device. If a line is indented then it is a continuation of the previous line and the two combined represent the entire Device Marking for that device.

(6) Lead finish/Ball material - Orderable Devices may have multiple material finish options. Finish options are separated by a vertical ruled line. Lead finish/Ball material values may wrap to two lines if the finish value exceeds the maximum column width.

Important Information and Disclaimer: The information provided on this page represents TI's knowledge and belief as of the date that it is provided. TI bases its knowledge and belief on information provided by third parties, and makes no representation or warranty as to the accuracy of such information. Efforts are underway to better integrate information from third parties. TI has taken and continues to take reasonable steps to provide representative and accurate information but may not have conducted destructive testing or chemical analysis on incoming materials and chemicals. TI and TI suppliers consider certain information to be proprietary, and thus CAS numbers and other limited information may not be available for release.

In no event shall TI's liability arising out of such information exceed the total purchase price of the TI part(s) at issue in this document sold by TI to Customer on an annual basis.

TAPE AND REEL INFORMATION

QUADRANT ASSIGNMENTS FOR PIN 1 ORIENTATION IN TAPE

*All dimensions are nominal

Device	Package Type	Package Drawing	Pins	SPQ	Reel Diameter (mm)	Reel Width W1 (mm)	A0 (mm)	B0 (mm)	K0 (mm)	P1 (mm)	W (mm)	Pin1 Quadrant
TRS3221ECDBR	SSOP	DB	16	2000	330.0	16.4	8.35	6.6	2.4	12.0	16.0	Q1
TRS3221ECPWR	TSSOP	PW	16	2000	330.0	12.4	6.9	5.6	1.6	8.0	12.0	Q1
TRS3221ECPWR	TSSOP	PW	16	2000	330.0	12.4	6.9	5.6	1.6	8.0	12.0	Q1
TRS3221EIDBR	SSOP	DB	16	2000	330.0	16.4	8.35	6.6	2.4	12.0	16.0	Q1
TRS3221EIPWR	TSSOP	PW	16	2000	330.0	12.4	6.9	5.6	1.6	8.0	12.0	Q1
TRS3221EIPWR	TSSOP	PW	16	2000	330.0	12.4	6.9	5.6	1.6	8.0	12.0	Q1
TRS3221EIRGTR	VQFN	RGT	16	3000	330.0	12.4	3.3	3.3	1.1	8.0	12.0	Q2

TAPE AND REEL BOX DIMENSIONS

*All dimensions are nominal

Device	Package Type	Package Drawing	Pins	SPQ	Length (mm)	Width (mm)	Height (mm)
TRS3221ECDBR	SSOP	DB	16	2000	356.0	356.0	35.0
TRS3221ECPWR	TSSOP	PW	16	2000	356.0	356.0	35.0
TRS3221ECPWR	TSSOP	PW	16	2000	367.0	367.0	35.0
TRS3221EIDBR	SSOP	DB	16	2000	356.0	356.0	35.0
TRS3221EIPWR	TSSOP	PW	16	2000	356.0	356.0	35.0
TRS3221EIPWR	TSSOP	PW	16	2000	367.0	367.0	35.0
TRS3221EIRGTR	VQFN	RGT	16	3000	367.0	367.0	35.0



4220204/A 02/2017

NOTES:

1. All linear dimensions are in millimeters. Any dimensions in parenthesis are for reference only. Dimensioning and tolerancing per ASME Y14.5M.
2. This drawing is subject to change without notice.
3. This dimension does not include mold flash, protrusions, or gate burrs. Mold flash, protrusions, or gate burrs shall not exceed 0.15 mm per side.
4. This dimension does not include interlead flash. Interlead flash shall not exceed 0.25 mm per side.
5. Reference JEDEC registration MO-153.

EXAMPLE BOARD LAYOUT

PW0016A

TSSOP - 1.2 mm max height

SMALL OUTLINE PACKAGE



LAND PATTERN EXAMPLE
EXPOSED METAL SHOWN
SCALE: 10X



SOLDER MASK DETAILS

4220204/A 02/2017

NOTES: (continued)

- 6. Publication IPC-7351 may have alternate designs.
- 7. Solder mask tolerances between and around signal pads can vary based on board fabrication site.

EXAMPLE STENCIL DESIGN

PW0016A

TSSOP - 1.2 mm max height

SMALL OUTLINE PACKAGE

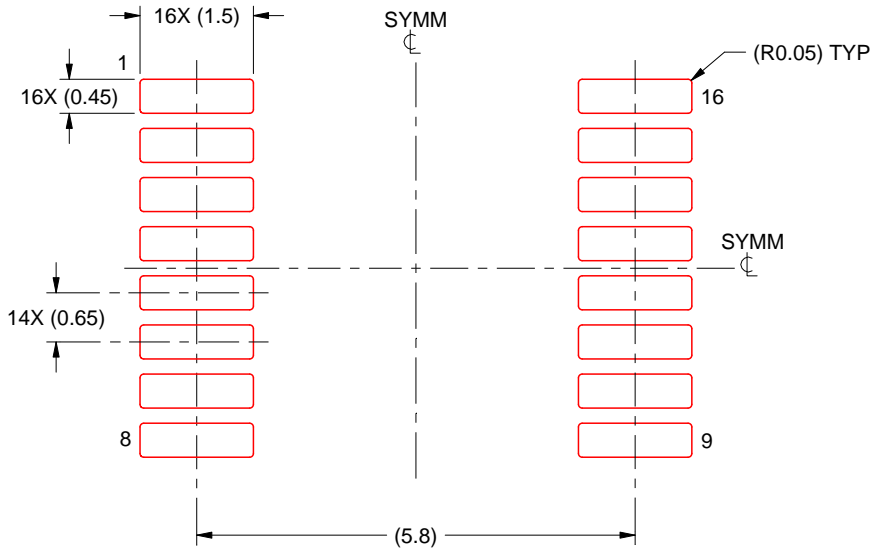

SOLDER PASTE EXAMPLE
BASED ON 0.125 mm THICK STENCIL
SCALE: 10X

4220204/A 02/2017

NOTES: (continued)

8. Laser cutting apertures with trapezoidal walls and rounded corners may offer better paste release. IPC-7525 may have alternate design recommendations.
9. Board assembly site may have different recommendations for stencil design.

DB0016A



PACKAGE OUTLINE

SSOP - 2 mm max height

SMALL OUTLINE PACKAGE

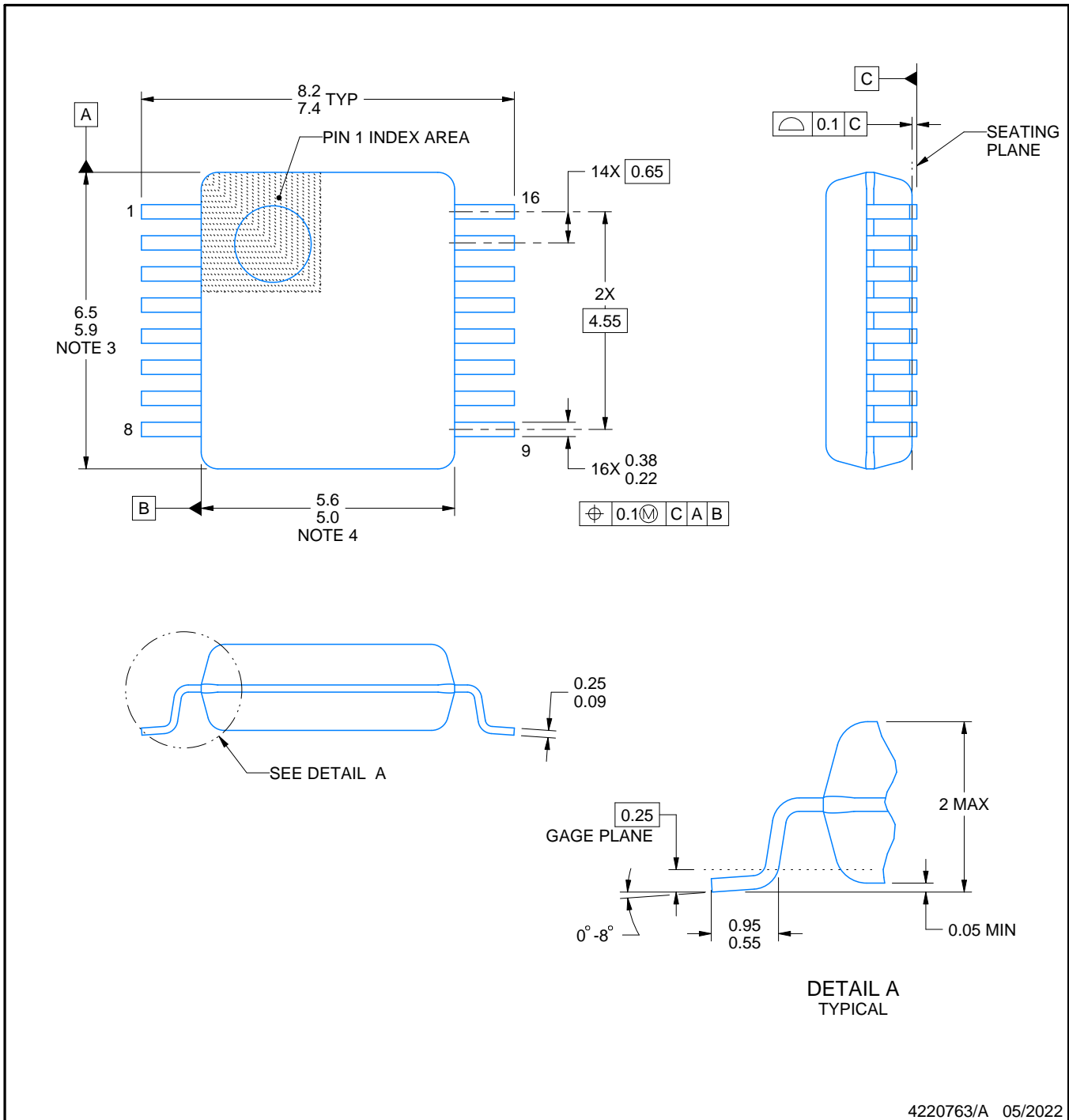

4220763/A 05/2022

NOTES:

1. All linear dimensions are in millimeters. Any dimensions in parenthesis are for reference only. Dimensioning and tolerancing per ASME Y14.5M.
2. This drawing is subject to change without notice.
3. This dimension does not include mold flash, protrusions, or gate burrs. Mold flash, protrusions, or gate burrs shall not exceed 0.15 mm per side.
4. Reference JEDEC registration MO-150.

EXAMPLE BOARD LAYOUT

DB0016A

SSOP - 2 mm max height

SMALL OUTLINE PACKAGE

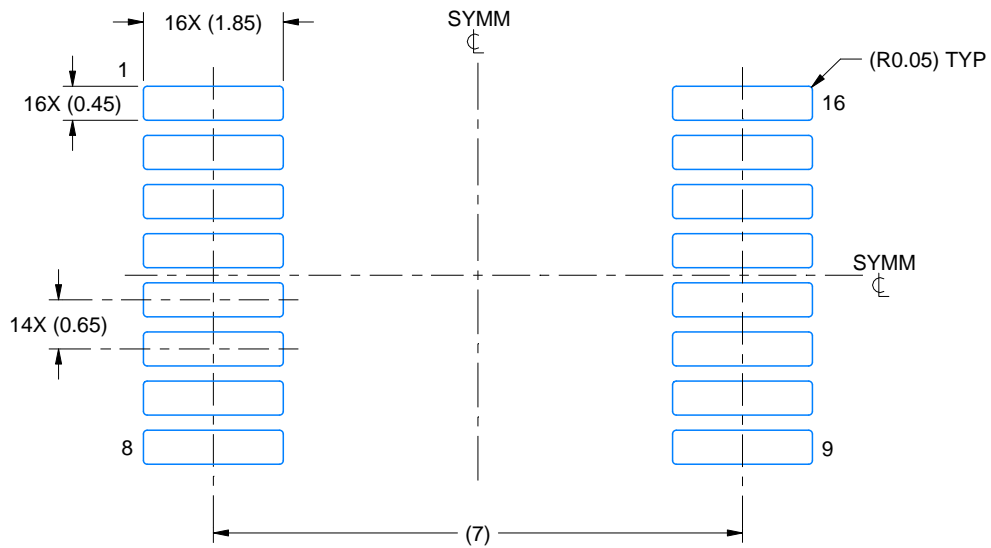

LAND PATTERN EXAMPLE
EXPOSED METAL SHOWN
SCALE: 10X

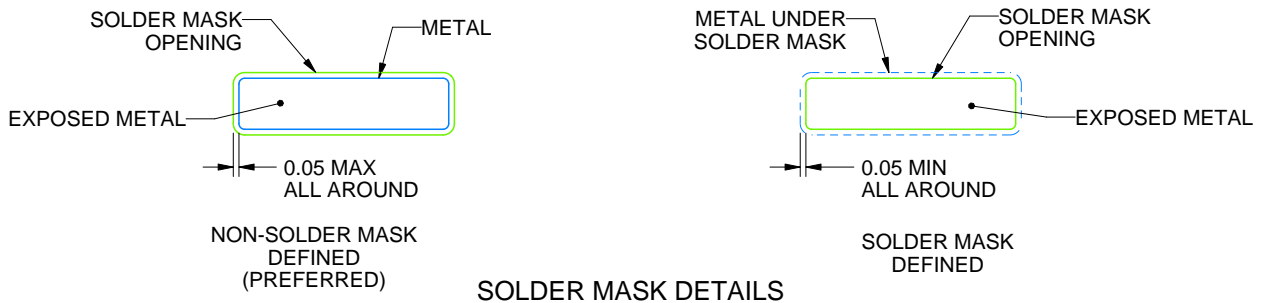

4220763/A 05/2022

NOTES: (continued)

- 5. Publication IPC-7351 may have alternate designs.
- 6. Solder mask tolerances between and around signal pads can vary based on board fabrication site.

EXAMPLE STENCIL DESIGN

DB0016A

SSOP - 2 mm max height

SMALL OUTLINE PACKAGE

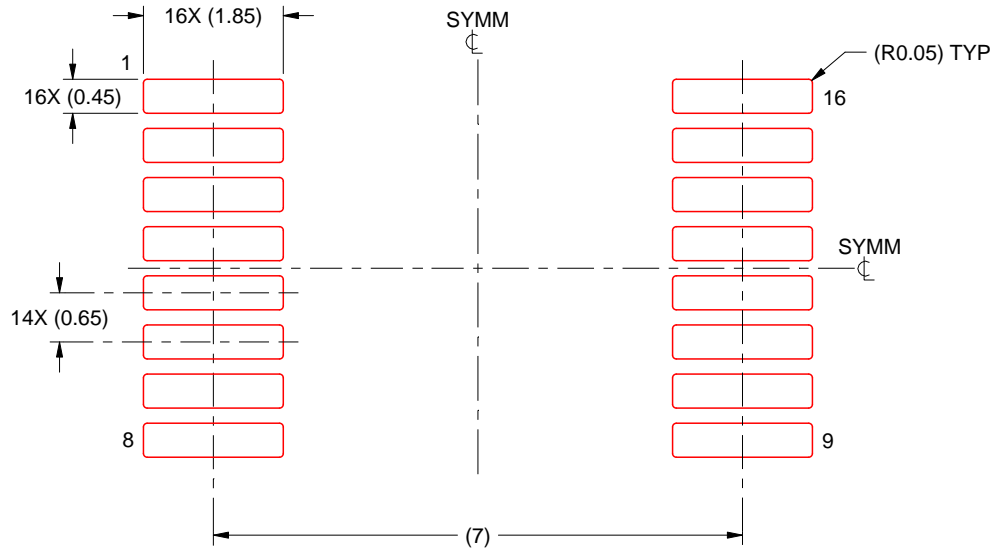

SOLDER PASTE EXAMPLE
BASED ON 0.125 mm THICK STENCIL
SCALE: 10X

4220763/A 05/2022

NOTES: (continued)

7. Laser cutting apertures with trapezoidal walls and rounded corners may offer better paste release. IPC-7525 may have alternate design recommendations.
8. Board assembly site may have different recommendations for stencil design.

RGT 16

GENERIC PACKAGE VIEW

VQFN - 1 mm max height

PLASTIC QUAD FLATPACK - NO LEAD

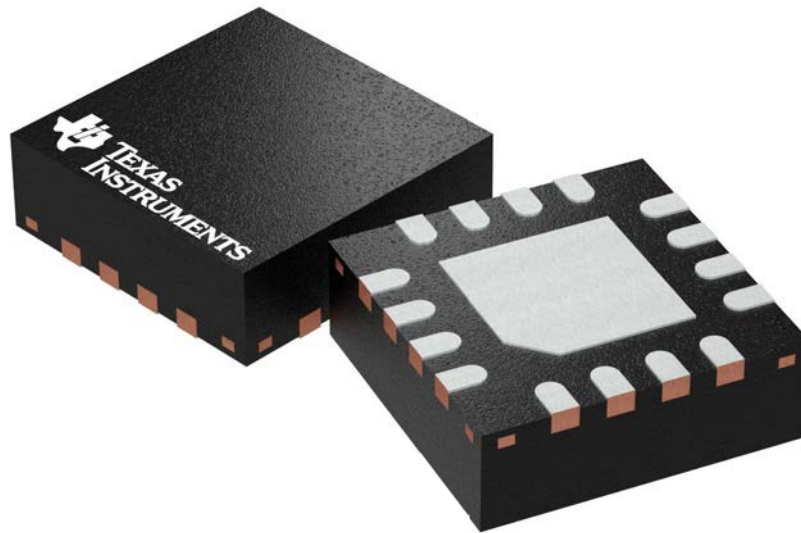

Images above are just a representation of the package family, actual package may vary.
Refer to the product data sheet for package details.

4203495/1

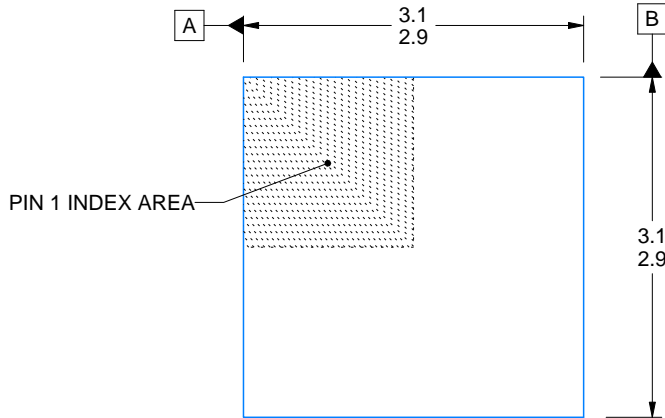
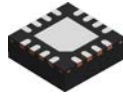

SIDE WALL METAL THICKNESS DIM A	
OPTION 1	OPTION 2
0.1	0.2

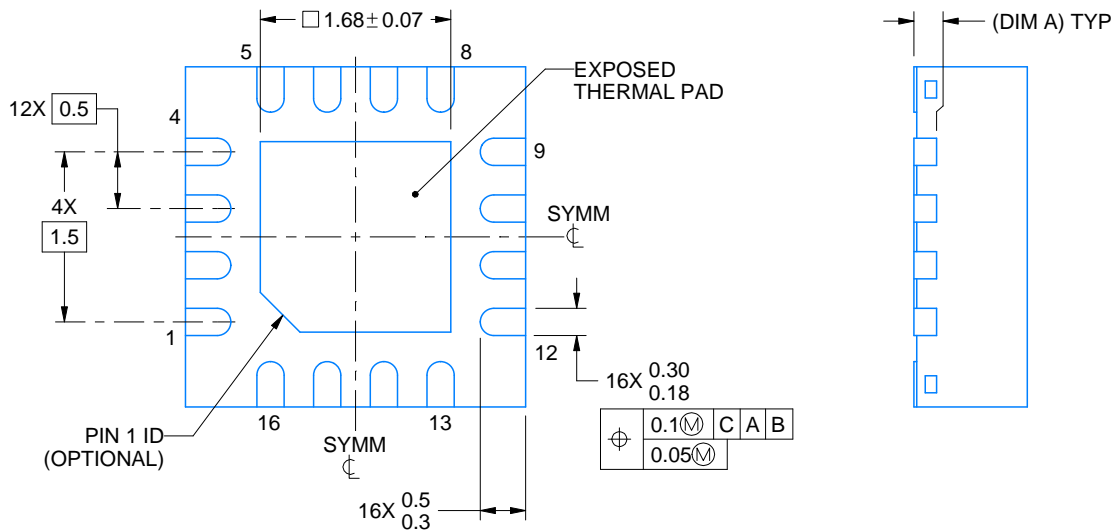
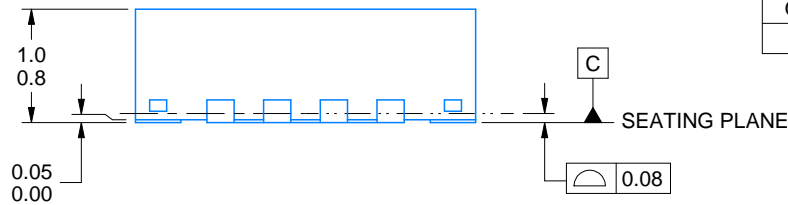

4222419/D 04/2022

NOTES:

1. All linear dimensions are in millimeters. Any dimensions in parenthesis are for reference only. Dimensioning and tolerancing per ASME Y14.5M.
2. This drawing is subject to change without notice.
3. The package thermal pad must be soldered to the printed circuit board for thermal and mechanical performance.

EXAMPLE BOARD LAYOUT

RGT0016C

VQFN - 1 mm max height

PLASTIC QUAD FLATPACK - NO LEAD

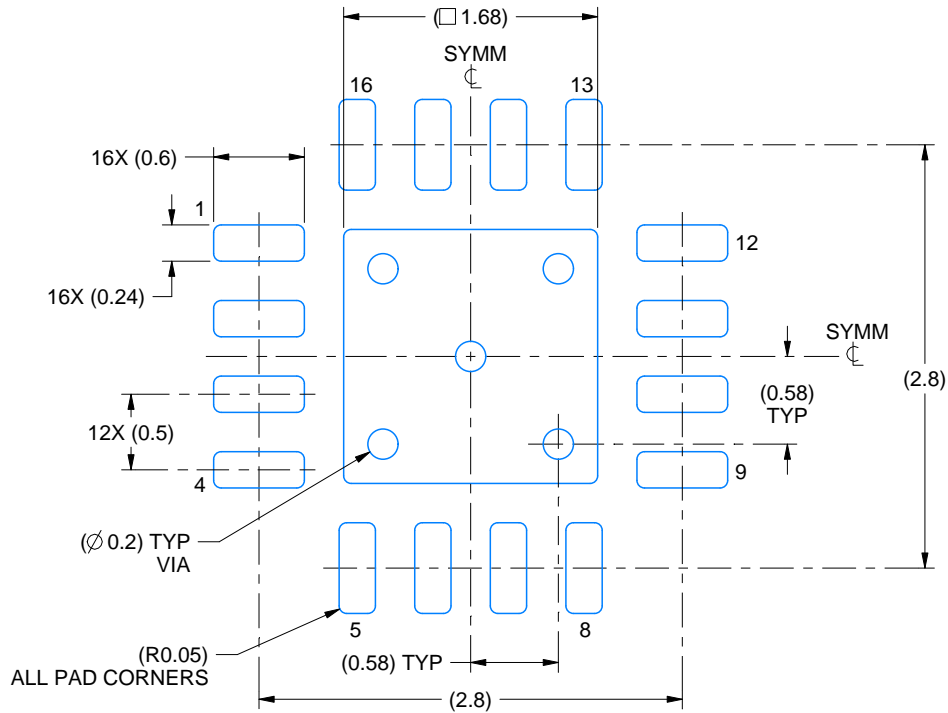

LAND PATTERN EXAMPLE
EXPOSED METAL SHOWN
SCALE:20X

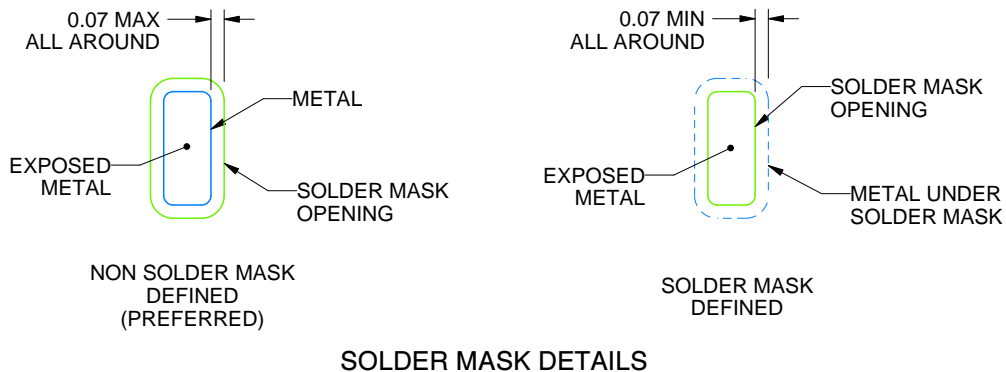

SOLDER MASK DETAILS

4222419/D 04/2022

NOTES: (continued)

4. This package is designed to be soldered to a thermal pad on the board. For more information, see Texas Instruments literature number SLUA271 (www.ti.com/lit/slua271).
5. Vias are optional depending on application, refer to device data sheet. If any vias are implemented, refer to their locations shown on this view. It is recommended that vias under paste be filled, plugged or tented.

EXAMPLE STENCIL DESIGN

RGT0016C

VQFN - 1 mm max height

PLASTIC QUAD FLATPACK - NO LEAD

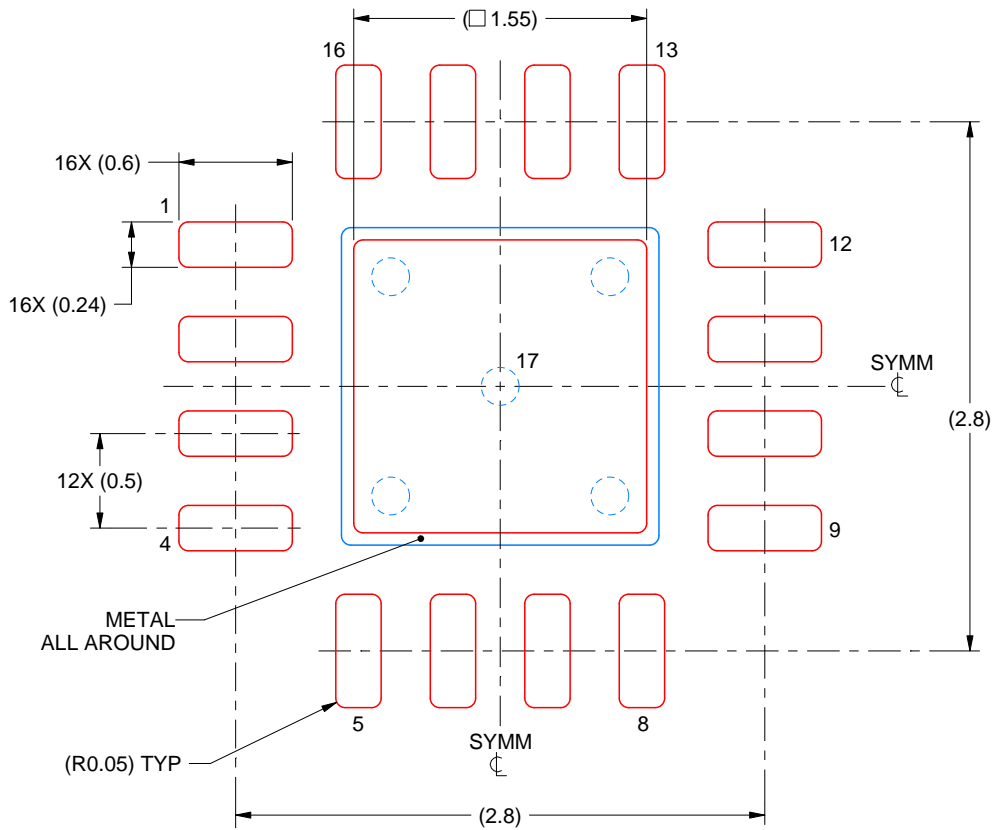

SOLDER PASTE EXAMPLE
BASED ON 0.125 mm THICK STENCIL

EXPOSED PAD 17:
85% PRINTED SOLDER COVERAGE BY AREA UNDER PACKAGE
SCALE:25X

4222419/D 04/2022

NOTES: (continued)

6. Laser cutting apertures with trapezoidal walls and rounded corners may offer better paste release. IPC-7525 may have alternate design recommendations.

IMPORTANT NOTICE AND DISCLAIMER

TI PROVIDES TECHNICAL AND RELIABILITY DATA (INCLUDING DATA SHEETS), DESIGN RESOURCES (INCLUDING REFERENCE DESIGNS), APPLICATION OR OTHER DESIGN ADVICE, WEB TOOLS, SAFETY INFORMATION, AND OTHER RESOURCES "AS IS" AND WITH ALL FAULTS, AND DISCLAIMS ALL WARRANTIES, EXPRESS AND IMPLIED, INCLUDING WITHOUT LIMITATION ANY IMPLIED WARRANTIES OF MERCHANTABILITY, FITNESS FOR A PARTICULAR PURPOSE OR NON-INFRINGEMENT OF THIRD PARTY INTELLECTUAL PROPERTY RIGHTS.

These resources are intended for skilled developers designing with TI products. You are solely responsible for (1) selecting the appropriate TI products for your application, (2) designing, validating and testing your application, and (3) ensuring your application meets applicable standards, and any other safety, security, regulatory or other requirements.

These resources are subject to change without notice. TI grants you permission to use these resources only for development of an application that uses the TI products described in the resource. Other reproduction and display of these resources is prohibited. No license is granted to any other TI intellectual property right or to any third party intellectual property right. TI disclaims responsibility for, and you will fully indemnify TI and its representatives against, any claims, damages, costs, losses, and liabilities arising out of your use of these resources.

TI's products are provided subject to [TI's Terms of Sale](#) or other applicable terms available either on ti.com or provided in conjunction with such TI products. TI's provision of these resources does not expand or otherwise alter TI's applicable warranties or warranty disclaimers for TI products.

TI objects to and rejects any additional or different terms you may have proposed.

Mailing Address: Texas Instruments, Post Office Box 655303, Dallas, Texas 75265
Copyright © 2022, Texas Instruments Incorporated

Looking for pricing, stock, or lifecycle information?

Click below to explore more details on WIN SOURCE:

 [View TRS3221ECPWR on WIN SOURCE](#)

 [Texas Instruments](#) Information

Optimize Your Supply Chain with WIN SOURCE Solutions

-  Global Sourcing Solution
-  Obsolete Management
-  Cost Control Management
-  Shortage Management
-  Alternative Solution
-  Excess Inventory Management