



**THE DATASHEET OF  
TRS213CDBR**



## FEATURES

- ESD Protection for RS-232 Bus Pins
  - $\pm 15$ -kV Human-Body Model (HBM)
- Meets or Exceeds the Requirements of TIA/EIA-232-F and ITU v.28 Standards
- Operates at 5-V  $V_{CC}$  Supply
- Four Drivers and Five Receivers
- Operates up to 120 kbit/s
- Low Supply Current in Shutdown Mode . . . 15  $\mu$ A Typ
- External Capacitors . . .  $4 \times 0.1$  F
- Designed to Be Interchangeable With Industry Standard '213 Devices
- Latch-Up Performance Exceeds 100 mA Per JESD 78, Class II

## APPLICATIONS

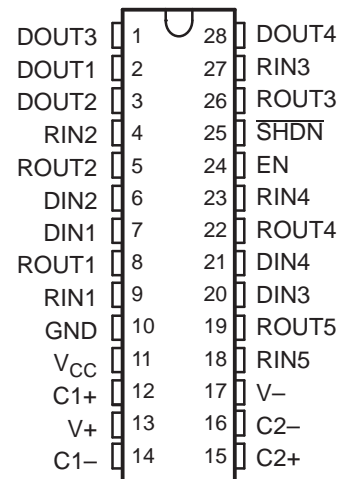
- Battery-Powered Systems
- PDAs
- Notebooks
- Laptops
- Palmtop PCs
- Hand-Held Equipment

## DESCRIPTION/ ORDER INFORMATION

The TRS213 device consists of four line drivers, five line receivers, and a dual charge-pump circuit with  $\pm 15$ -kV ESD protection pin to pin (serial-port connection pins, including GND). The device meets the requirements of TIA/EIA-232-F and provides the electrical interface between an asynchronous communication controller and the serial-port connector. The charge pump and four small external capacitors allow operation from a single 5-V supply. The devices operate at data signaling rates up to 120 kbit/s and a maximum of 30-V/ $\mu$ s driver output slew rate.

The TRS213 has an active-low shutdown ( $\overline{\text{SHDN}}$ ) and an active-high enable control (EN). In shutdown mode, the charge pumps are turned off,  $V+$  is pulled down to  $V_{CC}$ ,  $V-$  is pulled to GND, and the transmitter outputs are disabled. This reduces supply current typically to 1  $\mu$ A. Two receivers of the TRS213 are active during shutdown.

DB, DW, OR PW PACKAGE  
(TOP VIEW)



Please be aware that an important notice concerning availability, standard warranty, and use in critical applications of Texas Instruments semiconductor products and disclaimers thereto appears at the end of this data sheet.

**TRS213**  
**5-V MULTICHANNEL RS-232 LINE DRIVER/RECEIVER**  
**WITH  $\pm 15$ -kV ESD PROTECTION**

SLLS807–JUNE 2007

**ORDERING INFORMATION**

T <sub>A</sub>	PACKAGE <sup>(1)(2)</sup>		ORDERABLE PART NUMBER	TOP-SIDE MARKING
0°C to 70°C	SOIC – DW	Tube of 20	TRS213CDW	TRS213C
		Reel of 1000	TRS213CDWR	
	SSOP – DB	Tube of 50	TRS213CDB	TRS213C
		Reel of 2000	TRS213CDBR	
TSSOP – PW	Tape and reel	TRS213CPWR	TRS213C	
–40°C to 85°C	SOIC – DW	Tube of 20	TRS213IDW	TRS213I
		Reel of 1000	TRS213IDWR	
	SSOP – DB	Tube of 50	TRS213IDB	TRS213I
		Reel of 2000	TRS213IDBR	
	TSSOP – PW	Tape and reel	TRS213IPWR	TRS213I

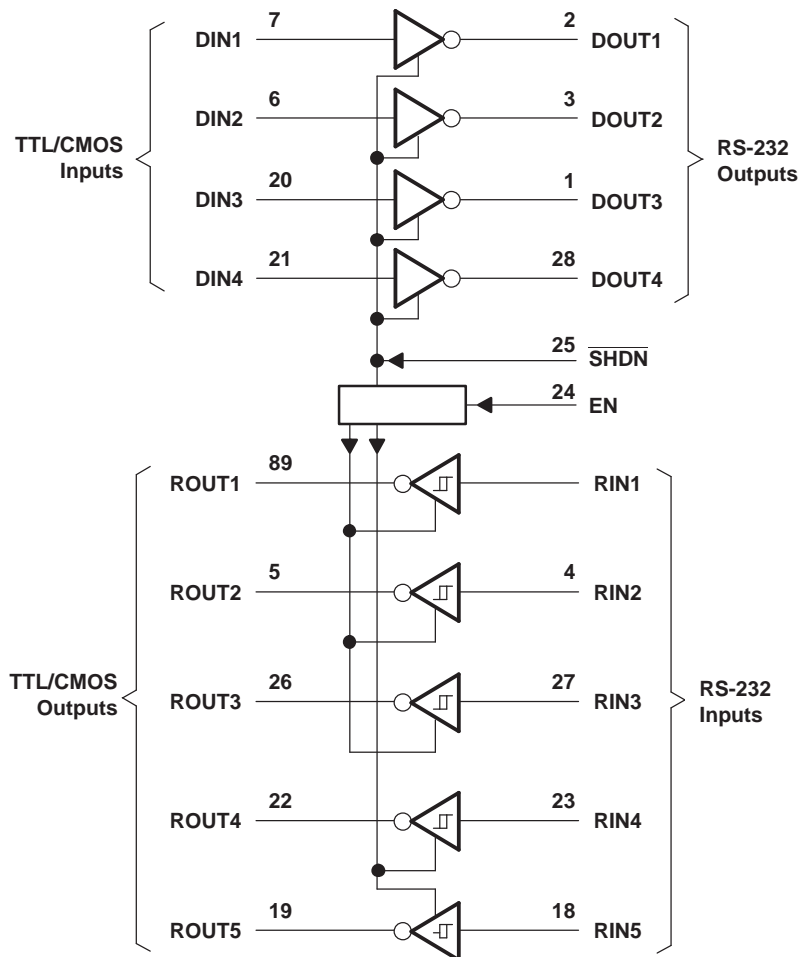
- (1) Package drawings, standard packing quantities, thermal data, symbolization, and PCB design guidelines are available at [www.ti.com/sc/package](http://www.ti.com/sc/package).
- (2) For the most current package and ordering information, see the Package Option Addendum at the end of this document, or see the TI website at [www.ti.com](http://www.ti.com).

**FUNCTION TABLE**

INPUTS		DRIVER D1–D4	RECEIVER		DEVICE STATUS
$\overline{\text{SHDN}}$	EN		R1–R3	R4–R5	
L	L	Z	Z	Z	Shutdown
L	H	Z	Z	Active <sup>(1)</sup>	Shutdown
H	L	All active	Z	Z	Normal operation
H	H	All active	Active	Active	Normal operation

- (1) See the V<sub>IT+</sub> and V<sub>IT-</sub> change in the Electrical Characteristics table.

**LOGIC DIAGRAM (POSITIVE LOGIC)**



# TRS213

## 5-V MULTICHANNEL RS-232 LINE DRIVER/RECEIVER WITH $\pm 15$ -kV ESD PROTECTION

SLLS807–JUNE 2007

### Absolute Maximum Ratings<sup>(1)</sup>

over operating free-air temperature range (unless otherwise noted)

		MIN	MAX	UNIT
V <sub>CC</sub>	Supply voltage range	-0.3	6	V
V+	Positive charge-pump voltage range <sup>(2)</sup>	V <sub>CC</sub> - 0.3	14	V
V-	Negative charge-pump voltage range <sup>(2)</sup>	0.3	-14	V
V <sub>I</sub>	Input voltage range	Drivers	V+ + 0.3	V
		Receivers	±30	
V <sub>O</sub>	Output voltage range	Drivers	V- - 0.3	V
		Receivers	-0.3	
DO <sub>UT</sub>	Short-circuit duration	Continuous		
θ <sub>JA</sub>	Package thermal impedance <sup>(3)(4)</sup>	DB package	62	C°/W
		DW package	46	
		PW package		
T <sub>J</sub>	Operating virtual junction temperature		150	C°
T <sub>stg</sub>	Storage temperature range	-65	150	C°

- (1) Stresses beyond those listed under "absolute maximum ratings" may cause permanent damage to the device. These are stress ratings only, and functional operation of the device at these or any other conditions beyond those indicated under "recommended operating conditions" is not implied. Exposure to absolute-maximum-rated conditions for extended periods may affect device reliability.
- (2) All voltages are with respect to network GND.
- (3) Maximum power dissipation is a function of T<sub>J</sub>(max), θ<sub>JA</sub>, and T<sub>A</sub>. The maximum allowable power dissipation at any allowable ambient temperature is P<sub>D</sub> = (T<sub>J</sub>(max) - T<sub>A</sub>)/θ<sub>JA</sub>. Operating at the absolute maximum T<sub>J</sub> of 150°C can affect reliability.
- (4) The package thermal impedance is calculated in accordance with JESD 51-7.

### Recommended Operating Conditions<sup>(1)</sup>

See [Figure 4](#)

			MIN	NOM	MAX	UNIT
Supply voltage			4.5	5	5.5	V
V <sub>IH</sub>	Driver high-level input voltage	DIN	2			V
	Control high-level input voltage	EN, $\overline{\text{SHDN}}$	2.4			
V <sub>IL</sub>	Driver and control low-level input voltage	DIN, EN, $\overline{\text{SHDN}}$			0.8	V
V <sub>I</sub>	Driver and control input voltage	DIN, EN, $\overline{\text{SHDN}}$	0		5.5	V
	Receiver input voltage	RIN	-30		30	
T <sub>A</sub>	Operating free-air temperature	TRS213C	0		70	°C
		TRS213I	-40		85	

- (1) Test conditions are C1–C4 = 0.1 μF at V<sub>CC</sub> = 5 V ± 0.5 V.

### Electrical Characteristics<sup>(1)</sup>

over operating free-air temperature range (unless otherwise noted)

PARAMETER	TEST CONDITIONS	MIN	TYP <sup>(2)</sup>	MAX	UNIT
I <sub>CC</sub>	Supply current No load, See <a href="#">Figure 6</a>		14	20	mA
I <sub>SHDN</sub>	Shutdown supply current T <sub>A</sub> = 25°C, See <a href="#">Figure 1</a>		15	50	μA

- (1) Test conditions are C1–C4 = 0.1 μF at V<sub>CC</sub> = 5 V ± 0.5 V.
- (2) All typical values are at V<sub>CC</sub> = 5 V, and T<sub>A</sub> = 25°C.

## DRIVER SECTION

### Electrical Characteristics<sup>(1)</sup>

over operating free-air temperature range (unless otherwise noted) (see Figure 4)

PARAMETER		TEST CONDITIONS	MIN	TYP <sup>(2)</sup>	MAX	UNIT
V <sub>OH</sub>	High-level output voltage	DOUT at R <sub>L</sub> = 3 k $\Omega$ to GND	5	9		V
V <sub>OL</sub>	Low-level output voltage	DOUT at R <sub>L</sub> = 3 k $\Omega$ to GND	–5	–9		V
I <sub>IH</sub>	Control high-level input current	EN, $\overline{\text{SHDN}}$ = 5 V		3	10	$\mu$ A
I <sub>IL</sub>	Driver low-level input current	DIN = 0 V		–15	–200	$\mu$ A
	Control low-level input current	EN, $\overline{\text{SHDN}}$ = 0 V		–3	–10	
I <sub>OS</sub> <sup>(3)</sup>	Short-circuit output current	V <sub>CC</sub> = 5.5 V, V <sub>O</sub> = 0 V		$\pm 10$	$\pm 60$	mA
r <sub>o</sub>	Output resistance	V <sub>CC</sub> , V+, and V– = 0 V, V <sub>O</sub> = $\pm 2$ V	300			$\Omega$

(1) Test conditions are C1–C4 = 0.1  $\mu$ F at V<sub>CC</sub> = 5 V  $\pm$  0.5 V

(2) All typical values are at V<sub>CC</sub> = 5 V, and T<sub>A</sub> = 25°C.

(3) Short-circuit durations should be controlled to prevent exceeding the device absolute power dissipation ratings, and not more than one output should be shorted at a time.

### Switching Characteristics<sup>(1)</sup>

over operating free-air temperature range (unless otherwise noted)

PARAMETER		TEST CONDITIONS	MIN	TYP <sup>(2)</sup>	MAX	UNIT
	Maximum data rate	C <sub>L</sub> = 50 pF to 1000 pF, One DO <sub>UT</sub> switching, R <sub>L</sub> = 3 k $\Omega$ to 7 k $\Omega$ , See Figure 3	120			kbit/s
t <sub>PLH(D)</sub>	Propagation delay time, low- to high-level output	C <sub>L</sub> = 2500 pF, All drivers loaded, R <sub>L</sub> = 3 k $\Omega$ , See Figure 3		2		$\mu$ s
t <sub>PHL(D)</sub>	Propagation delay time, high- to low-level output	C <sub>L</sub> = 2500 pF, All drivers loaded, R <sub>L</sub> = 3 k $\Omega$ , See Figure 3		2		$\mu$ s
t <sub>sk(p)</sub>	Pulse skew <sup>(3)</sup>	C <sub>L</sub> = 150 pF to 2500 pF, See Figure 3, R <sub>L</sub> = 3 k $\Omega$ to 7 k $\Omega$		300		ns
SR(tr)	Slew rate, transition region (see Figure 2)	C <sub>L</sub> = 50 pF to 1000 pF, V <sub>CC</sub> = 5 V, R <sub>L</sub> = 3 k $\Omega$ to 7 k $\Omega$	3	6	30	V/ $\mu$ s

(1) Test conditions are C1–C4 = 0.1  $\mu$ F at V<sub>CC</sub> = 5 V  $\pm$  0.5 V.

(2) All typical values are at V<sub>CC</sub> = 5 V, and T<sub>A</sub> = 25°C.

(3) Pulse skew is defined as (t<sub>PLH</sub> – t<sub>PHL</sub>) of each channel of the same device.

### ESD Protection

over operating free-air temperature range (unless otherwise noted)

PIN	TEST CONDITIONS	TYP	UNIT
DO <sub>UT</sub>	Human-Body Model	$\pm 15$	kV

# TRS213

## 5-V MULTICHANNEL RS-232 LINE DRIVER/RECEIVER WITH $\pm 15$ -kV ESD PROTECTION

SLLS807–JUNE 2007

### RECEIVER SECTION

#### Electrical Characteristics<sup>(1)</sup>

over operating free-air temperature range (unless otherwise noted) (see [Figure 6](#))

PARAMETER		TEST CONDITIONS		MIN	TYP <sup>(2)</sup>	MAX	UNIT	
V <sub>OH</sub>	High-level output voltage	I <sub>OH</sub> = -1 mA		V <sub>CC</sub> - 0.4			V	
V <sub>OL</sub>	Low-level output voltage	I <sub>OH</sub> = 1.6 mA		0.4			V	
V <sub>IT+</sub>	Positive-going input threshold voltage	V <sub>CC</sub> = 5 V, T <sub>A</sub> = 25°C	Active mode	1.7		2.4	V	
			Shutdown mode (R4–R5)	1.5		2.4		
V <sub>IT-</sub>	Negative-going input threshold voltage	V <sub>CC</sub> = 5 V, T <sub>A</sub> = 25°C	Active mode	0.8		1.2	V	
			Shutdown mode (R4–R5)	0.6		1.5		
V <sub>hys</sub> <sup>(3)</sup>	Input hysteresis (V <sub>IT+</sub> , V <sub>IT-</sub> )	V <sub>CC</sub> = 5 V		0.5		1	V	
r <sub>I</sub>	Input resistance	V <sub>CC</sub> = 5 V, T <sub>A</sub> = 25°C		3		5	7	kΩ
Output leakage current		EN = 0 V, 0 ≤ ROUT ≤ V <sub>CC</sub> , R1–R3		±0.05		±10	μA	

(1) Test conditions are C1–C4 = 0.1 μF at V<sub>CC</sub> = 5 V ± 0.5 V.

(2) All typical values are at V<sub>CC</sub> = 5 V, and T<sub>A</sub> = 25°C.

(3) No hysteresis in shutdown mode

#### Switching Characteristics<sup>(1)</sup>

over operating free-air temperature range (unless otherwise noted)

PARAMETER		TEST CONDITIONS		MIN	TYP <sup>(2)</sup>	MAX	UNIT
t <sub>PLH(R)</sub>	Propagation delay time, low- to high-level output	C <sub>L</sub> = 150 pF, See <a href="#">Figure 4</a>	SHDN = V <sub>CC</sub>	0.5		10	μs
			SHDN = 0 V, R4–R5	4		40	
t <sub>PHL(R)</sub>	Propagation delay time, high- to low-level output	C <sub>L</sub> = 150 pF, See <a href="#">Figure 4</a>		0.5		10	μs
t <sub>en</sub>	Output enable time	C <sub>L</sub> = 150 pF, See <a href="#">Figure 5</a>		600			ns
t <sub>dis</sub>	Output disable time	C <sub>L</sub> = 150 pF, See <a href="#">Figure 5</a>		200			ns

(1) Test conditions are C1–C4 = 0.1 μF at V<sub>CC</sub> = 5 V ± 0.5 V.

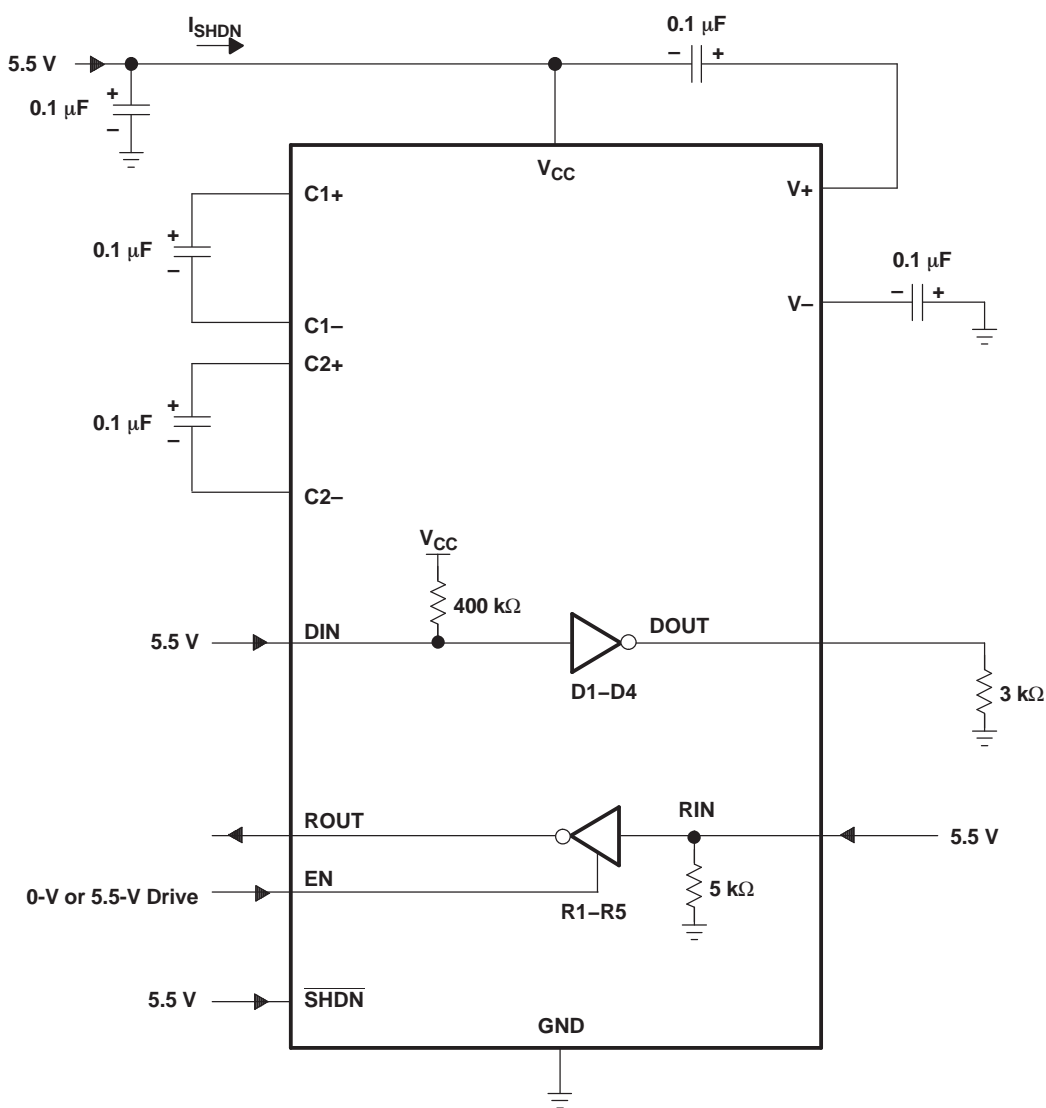
(2) All typical values are at V<sub>CC</sub> = 5 V, and T<sub>A</sub> = 25°C.

#### ESD Protection

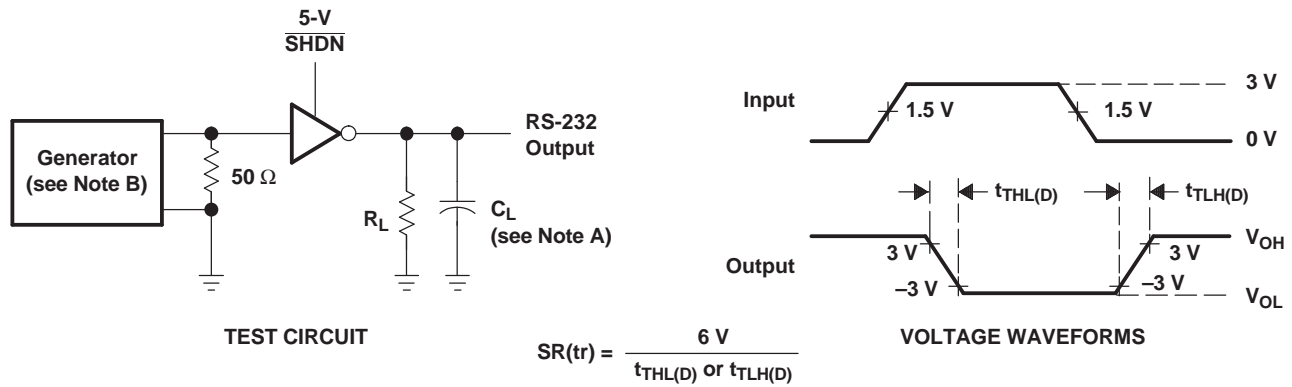
over operating free-air temperature range (unless otherwise noted)

PIN	TEST CONDITIONS	TYP	UNIT
RIN	Human-Body Model	±15	kV

**PARAMETER MEASUREMENT INFORMATION**

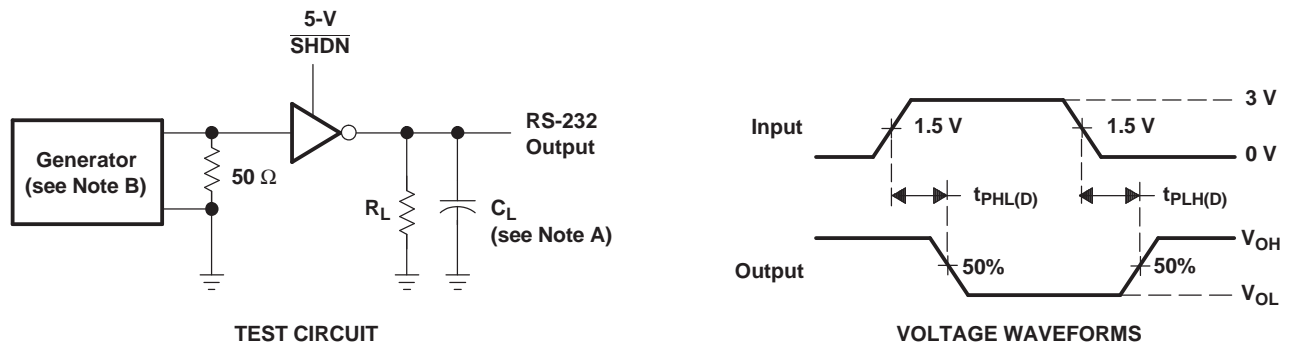


**Figure 1. Shutdown Current Test Circuit**



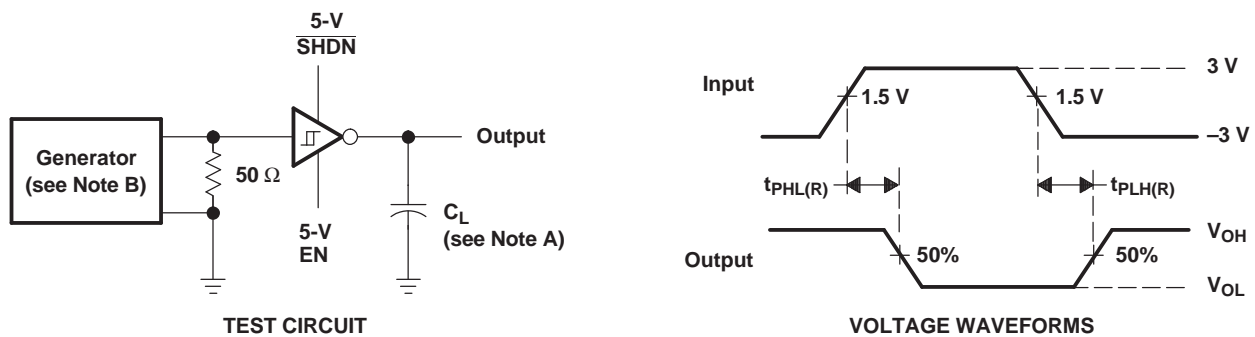
NOTES: A.  $C_L$  includes probe and jig capacitance.  
B. The pulse generator has the following characteristics:  $Z_O = 50\ \Omega$ , 50% duty cycle,  $t_r \leq 10\text{ ns}$ ,  $t_f \leq 10\text{ ns}$ .

Figure 2. Driver Slew Rate



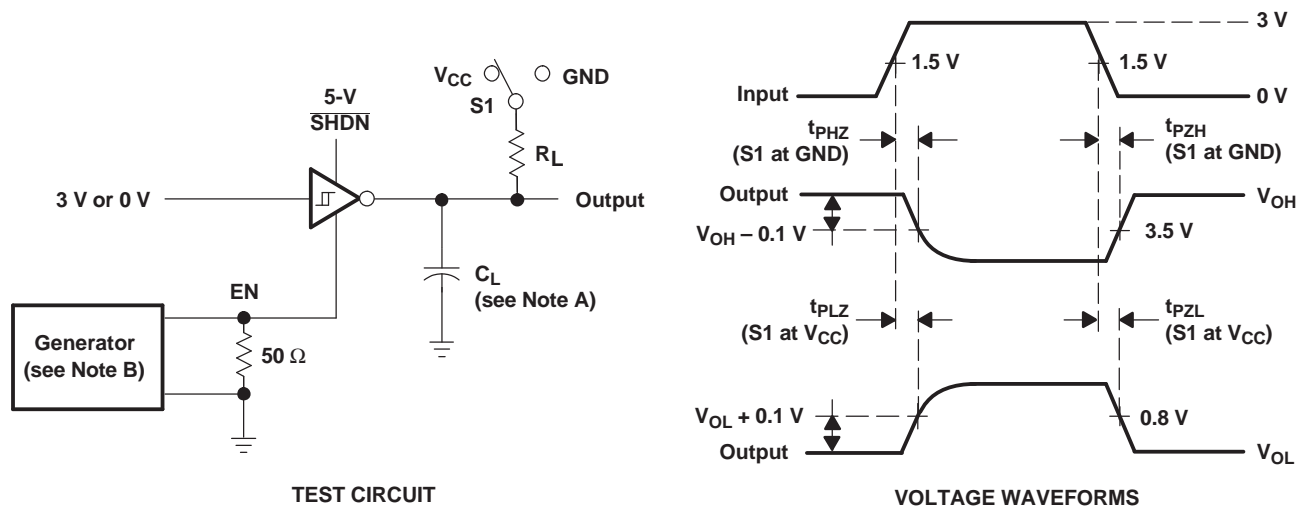
NOTES: A.  $C_L$  includes probe and jig capacitance.  
B. The pulse generator has the following characteristics:  $Z_O = 50\ \Omega$ , 50% duty cycle,  $t_r \leq 10\text{ ns}$ ,  $t_f \leq 10\text{ ns}$ .

Figure 3. Driver Pulse Skew and Propagation Delay Times



NOTES: A.  $C_L$  includes probe and jig capacitance.  
B. The pulse generator has the following characteristics:  $Z_O = 50\ \Omega$ , 50% duty cycle,  $t_r \leq 10\text{ ns}$ ,  $t_f \leq 10\text{ ns}$ .

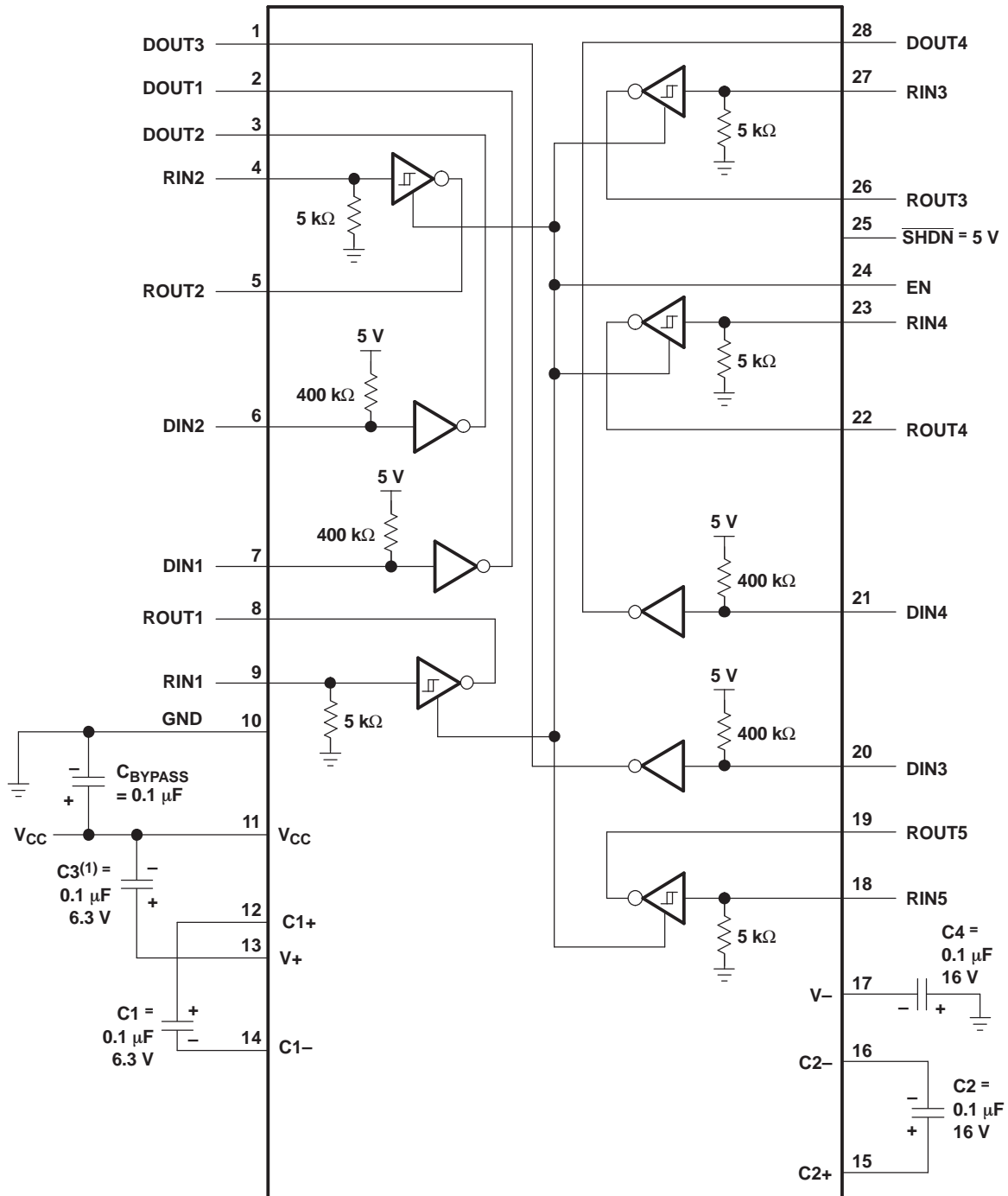
Figure 4. Receiver Propagation Delay Times



- NOTES:
- A.  $C_L$  includes probe and jig capacitance.
  - B. The pulse generator has the following characteristics:  $Z_O = 50 \Omega$ , 50% duty cycle,  $t_r \leq 10$  ns,  $t_f \leq 10$  ns.
  - C.  $t_{PLZ}$  and  $t_{PHZ}$  are the same as  $t_{dis}$ .
  - D.  $t_{PZL}$  and  $t_{PZH}$  are the same as  $t_{en}$ .

Figure 5. Receiver Enable and Disable Times

APPLICATION INFORMATION



(1) C3 can be connected to  $V_{CC}$  or GND.

NOTES: A. Resistor values shown are nominal.

B. Nonpolarized ceramic capacitors are acceptable. If polarized tantalum or electrolytic capacitors are used, they should be connected as shown.

Figure 6. Typical Operating Circuit and Capacitor Values

**PACKAGING INFORMATION**

Orderable Device	Status (1)	Package Type	Package Drawing	Pins	Package Qty	Eco Plan (2)	Lead finish/ Ball material (6)	MSL Peak Temp (3)	Op Temp (°C)	Device Marking (4/5)	Samples
TRS213IDBR	ACTIVE	SSOP	DB	28	2000	RoHS & Green	NIPDAU	Level-1-260C-UNLIM	-40 to 85	TRS213I	<a href="#">Samples</a>
TRS213IDWR	ACTIVE	SOIC	DW	28	1000	RoHS & Green	NIPDAU	Level-1-260C-UNLIM	-40 to 85	TRS213I	<a href="#">Samples</a>

(1) The marketing status values are defined as follows:

**ACTIVE:** Product device recommended for new designs.

**LIFEBUY:** TI has announced that the device will be discontinued, and a lifetime-buy period is in effect.

**NRND:** Not recommended for new designs. Device is in production to support existing customers, but TI does not recommend using this part in a new design.

**PREVIEW:** Device has been announced but is not in production. Samples may or may not be available.

**OBSOLETE:** TI has discontinued the production of the device.

(2) **RoHS:** TI defines "RoHS" to mean semiconductor products that are compliant with the current EU RoHS requirements for all 10 RoHS substances, including the requirement that RoHS substance do not exceed 0.1% by weight in homogeneous materials. Where designed to be soldered at high temperatures, "RoHS" products are suitable for use in specified lead-free processes. TI may reference these types of products as "Pb-Free".

**RoHS Exempt:** TI defines "RoHS Exempt" to mean products that contain lead but are compliant with EU RoHS pursuant to a specific EU RoHS exemption.

**Green:** TI defines "Green" to mean the content of Chlorine (Cl) and Bromine (Br) based flame retardants meet JS709B low halogen requirements of <=1000ppm threshold. Antimony trioxide based flame retardants must also meet the <=1000ppm threshold requirement.

(3) MSL, Peak Temp. - The Moisture Sensitivity Level rating according to the JEDEC industry standard classifications, and peak solder temperature.

(4) There may be additional marking, which relates to the logo, the lot trace code information, or the environmental category on the device.

(5) Multiple Device Markings will be inside parentheses. Only one Device Marking contained in parentheses and separated by a "~" will appear on a device. If a line is indented then it is a continuation of the previous line and the two combined represent the entire Device Marking for that device.

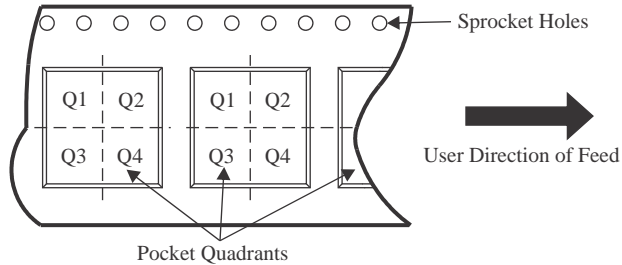
(6) Lead finish/Ball material - Orderable Devices may have multiple material finish options. Finish options are separated by a vertical ruled line. Lead finish/Ball material values may wrap to two lines if the finish value exceeds the maximum column width.

**Important Information and Disclaimer:**The information provided on this page represents TI's knowledge and belief as of the date that it is provided. TI bases its knowledge and belief on information provided by third parties, and makes no representation or warranty as to the accuracy of such information. Efforts are underway to better integrate information from third parties. TI has taken and continues to take reasonable steps to provide representative and accurate information but may not have conducted destructive testing or chemical analysis on incoming materials and chemicals. TI and TI suppliers consider certain information to be proprietary, and thus CAS numbers and other limited information may not be available for release.

In no event shall TI's liability arising out of such information exceed the total purchase price of the TI part(s) at issue in this document sold by TI to Customer on an annual basis.



**TAPE AND REEL INFORMATION**

**QUADRANT ASSIGNMENTS FOR PIN 1 ORIENTATION IN TAPE**


\*All dimensions are nominal

Device	Package Type	Package Drawing	Pins	SPQ	Reel Diameter (mm)	Reel Width W1 (mm)	A0 (mm)	B0 (mm)	K0 (mm)	P1 (mm)	W (mm)	Pin1 Quadrant
TRS213IDBR	SSOP	DB	28	2000	330.0	16.4	8.2	10.5	2.5	12.0	16.0	Q1
TRS213IDWR	SOIC	DW	28	1000	330.0	32.4	11.35	18.67	3.1	16.0	32.0	Q1

**TAPE AND REEL BOX DIMENSIONS**


\*All dimensions are nominal

Device	Package Type	Package Drawing	Pins	SPQ	Length (mm)	Width (mm)	Height (mm)
TRS213IDBR	SSOP	DB	28	2000	356.0	356.0	35.0
TRS213IDWR	SOIC	DW	28	1000	350.0	350.0	66.0

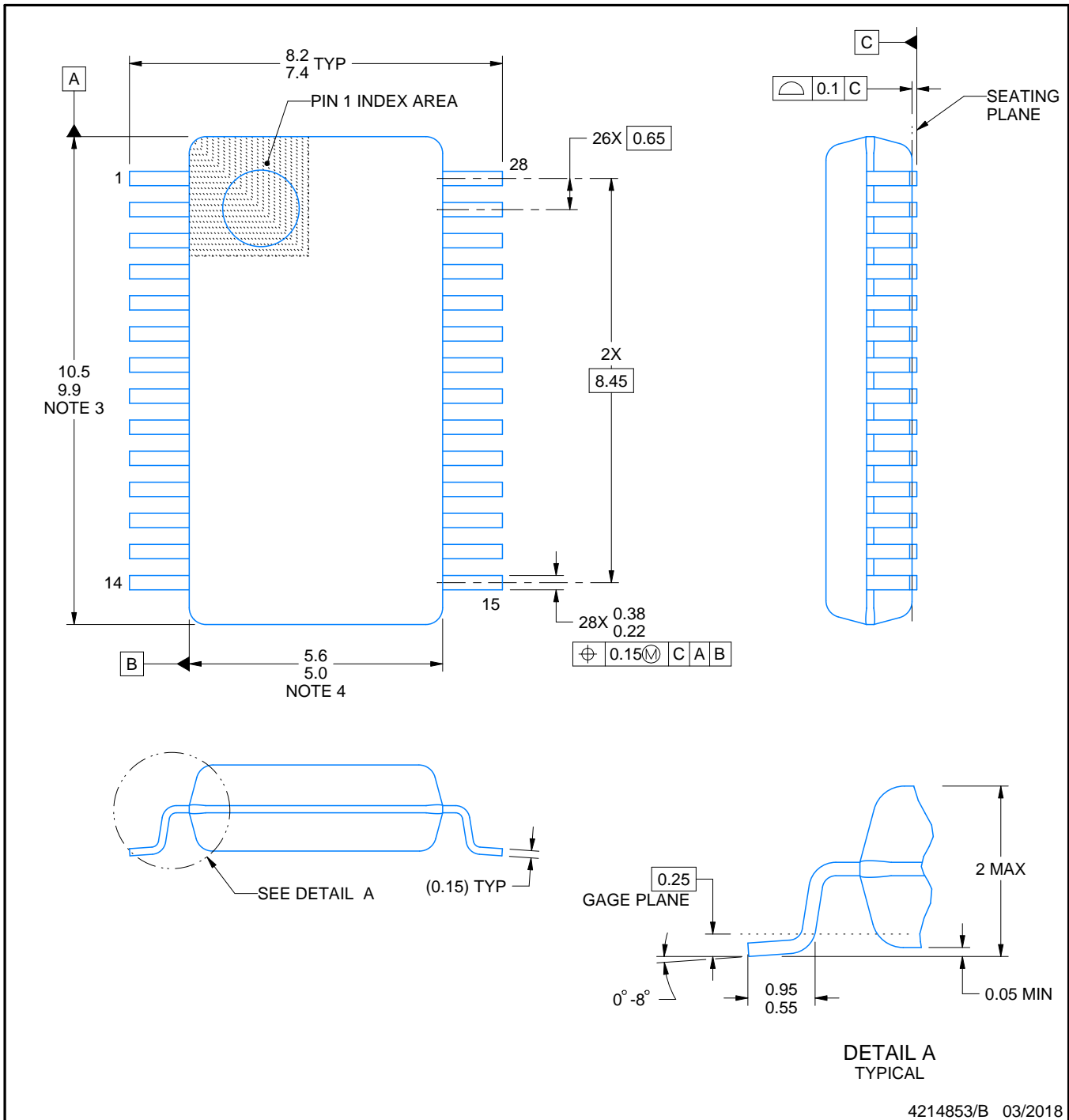
# DB0028A



# PACKAGE OUTLINE

## SSOP - 2 mm max height

SMALL OUTLINE PACKAGE



4214853/B 03/2018

### NOTES:

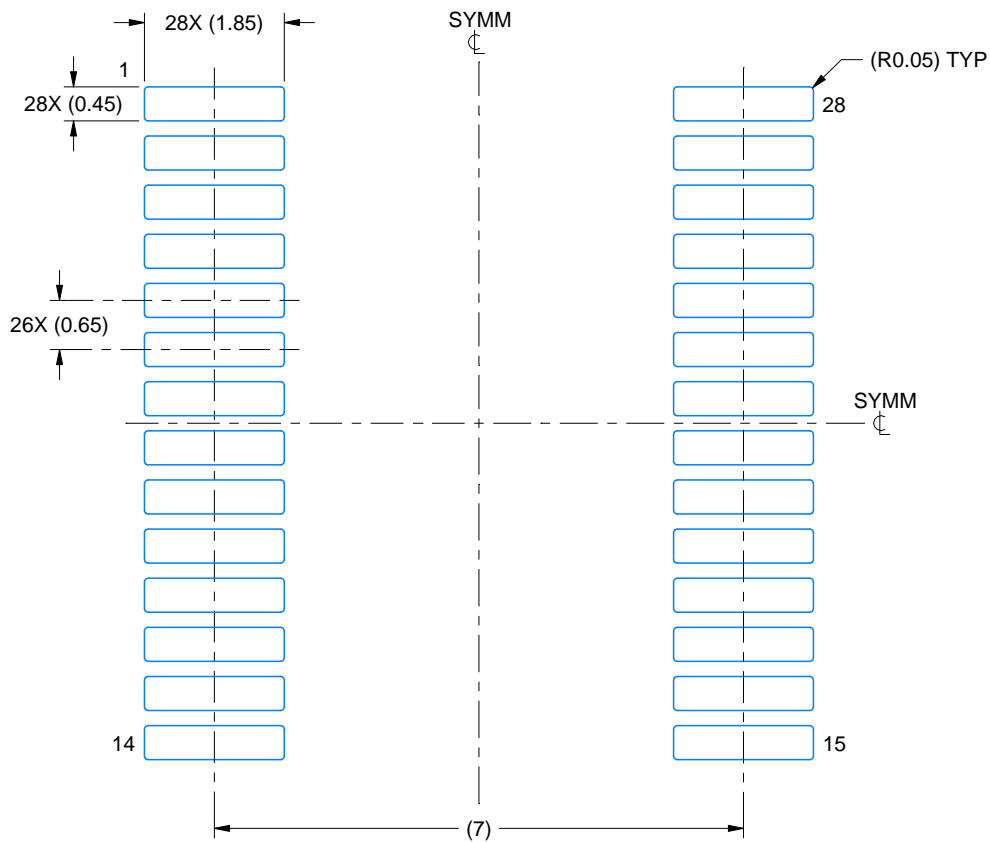
1. All linear dimensions are in millimeters. Any dimensions in parenthesis are for reference only. Dimensioning and tolerancing per ASME Y14.5M.
2. This drawing is subject to change without notice.
3. This dimension does not include mold flash, protrusions, or gate burrs. Mold flash, protrusions, or gate burrs shall not exceed 0.15 mm per side.
4. This dimension does not include interlead flash. Interlead flash shall not exceed 0.25 mm per side.
5. Reference JEDEC registration MO-150.

# EXAMPLE BOARD LAYOUT

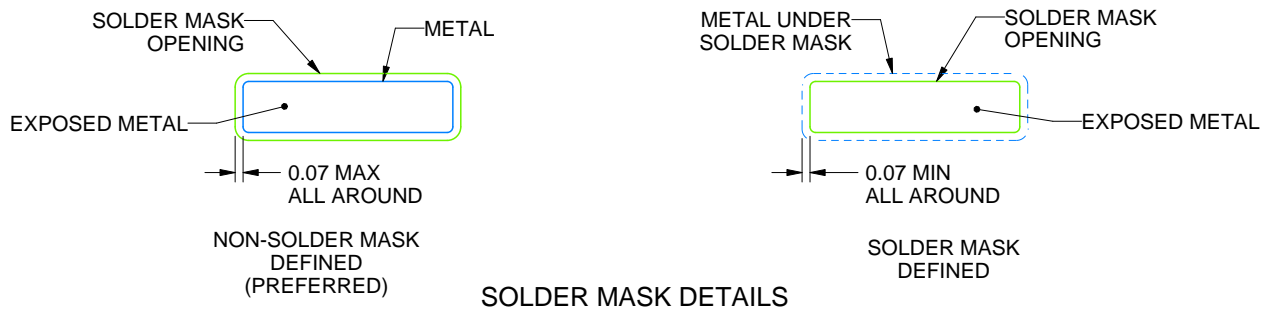
DB0028A

SSOP - 2 mm max height

SMALL OUTLINE PACKAGE



LAND PATTERN EXAMPLE  
EXPOSED METAL SHOWN  
SCALE: 10X



4214853/B 03/2018

NOTES: (continued)

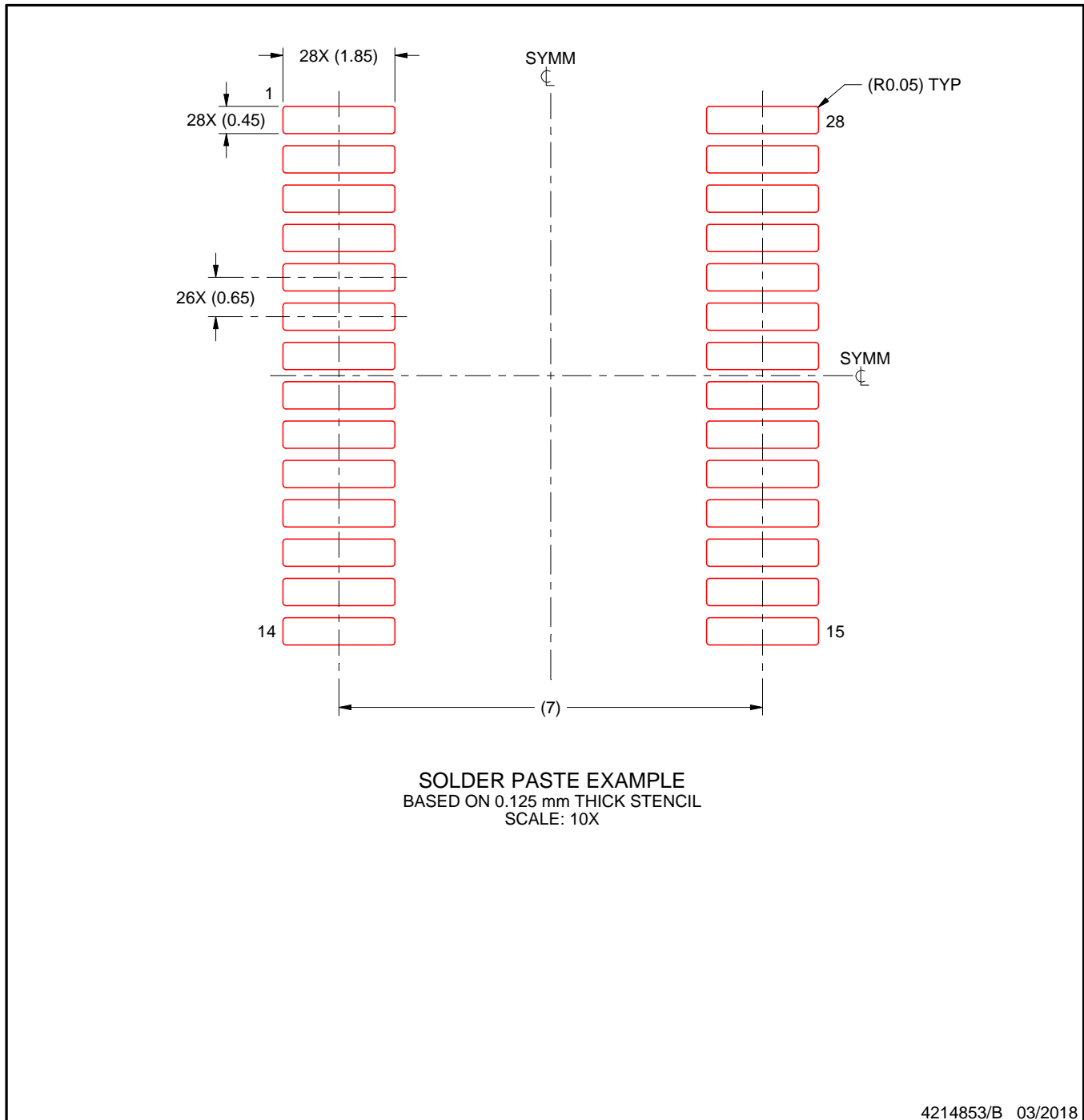
- 6. Publication IPC-7351 may have alternate designs.
- 7. Solder mask tolerances between and around signal pads can vary based on board fabrication site.

# EXAMPLE STENCIL DESIGN

DB0028A

SSOP - 2 mm max height

SMALL OUTLINE PACKAGE

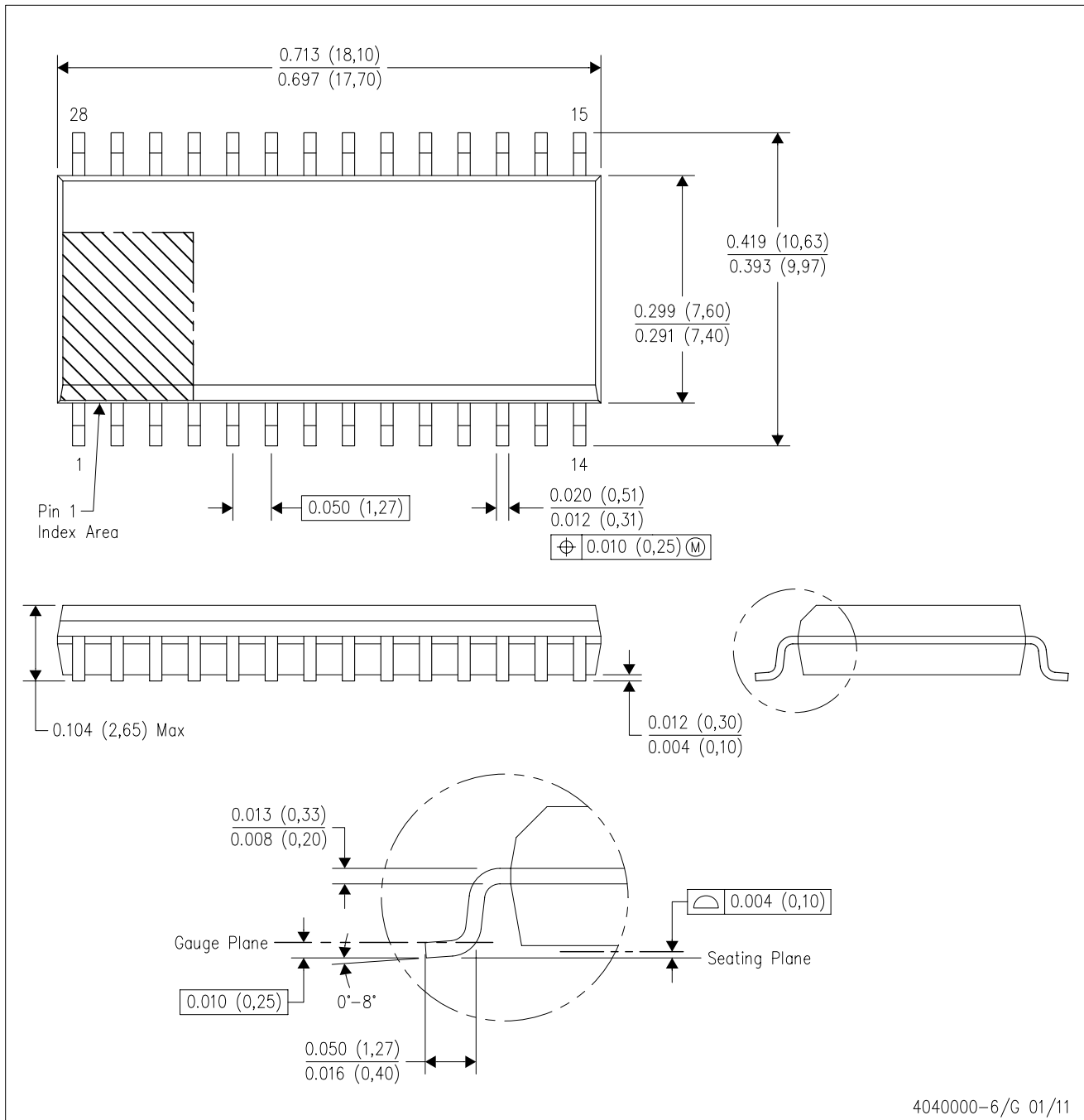


NOTES: (continued)

8. Laser cutting apertures with trapezoidal walls and rounded corners may offer better paste release. IPC-7525 may have alternate design recommendations.
9. Board assembly site may have different recommendations for stencil design.

DW (R-PDSO-G28)

PLASTIC SMALL OUTLINE



- NOTES:
- All linear dimensions are in inches (millimeters). Dimensioning and tolerancing per ASME Y14.5M-1994.
  - This drawing is subject to change without notice.
  - Body dimensions do not include mold flash or protrusion not to exceed 0.006 (0,15).
  - Falls within JEDEC MS-013 variation AE.

## IMPORTANT NOTICE AND DISCLAIMER

TI PROVIDES TECHNICAL AND RELIABILITY DATA (INCLUDING DATA SHEETS), DESIGN RESOURCES (INCLUDING REFERENCE DESIGNS), APPLICATION OR OTHER DESIGN ADVICE, WEB TOOLS, SAFETY INFORMATION, AND OTHER RESOURCES "AS IS" AND WITH ALL FAULTS, AND DISCLAIMS ALL WARRANTIES, EXPRESS AND IMPLIED, INCLUDING WITHOUT LIMITATION ANY IMPLIED WARRANTIES OF MERCHANTABILITY, FITNESS FOR A PARTICULAR PURPOSE OR NON-INFRINGEMENT OF THIRD PARTY INTELLECTUAL PROPERTY RIGHTS.

These resources are intended for skilled developers designing with TI products. You are solely responsible for (1) selecting the appropriate TI products for your application, (2) designing, validating and testing your application, and (3) ensuring your application meets applicable standards, and any other safety, security, regulatory or other requirements.

These resources are subject to change without notice. TI grants you permission to use these resources only for development of an application that uses the TI products described in the resource. Other reproduction and display of these resources is prohibited. No license is granted to any other TI intellectual property right or to any third party intellectual property right. TI disclaims responsibility for, and you will fully indemnify TI and its representatives against, any claims, damages, costs, losses, and liabilities arising out of your use of these resources.

TI's products are provided subject to [TI's Terms of Sale](#) or other applicable terms available either on [ti.com](https://www.ti.com) or provided in conjunction with such TI products. TI's provision of these resources does not expand or otherwise alter TI's applicable warranties or warranty disclaimers for TI products.

TI objects to and rejects any additional or different terms you may have proposed.

Mailing Address: Texas Instruments, Post Office Box 655303, Dallas, Texas 75265  
Copyright © 2024, Texas Instruments Incorporated

## Looking for pricing, stock, or lifecycle information?

Click below to explore more details on WIN SOURCE:

 [View TRS213CDBR](#) on WIN SOURCE

 [Texas Instruments](#) Information

## Optimize Your Supply Chain with WIN SOURCE Solutions

-  Global Sourcing Solution
-  Obsolete Management
-  Cost Control Management
-  Shortage Management
-  Alternative Solution
-  Excess Inventory Management