



THE DATASHEET OF TPS65149RSHR



Power Management Guide

 TEXAS INSTRUMENTS

POWER
TO DO ANYTHING.

www.ti.com/power

2018



Power Management Guide

Introduction and Contents

Texas Instruments (TI) offers complete power solutions with a full line of high-performance products. These products, which range from standard linear regulators to highly efficient DC/DC converters and battery management, are tailored to meet your design challenges. And, TI makes designing easier with leading-edge support tools such as WEBENCH® circuit design and selection simulation services, a broad selection of evaluation modules (EVMs), application notes, comprehensive technical documentation and more. Also, with more than 30,000 products in stock, the TI store is your one-stop shop for ICs and evaluation tools.

Included in this selection guide are design factors, featured products, graphic representations of portfolios, parametric tables and a device index to help you quickly find individual devices.

For information about HiRel and military versions of Power Management products, please visit:

www.ti.com/hirel

For information about automotive-qualified Power Management products, please visit:

www.ti.com/automotive

Table of Contents

3 Portable and Line Power Solutions

- 3 Line Power Solutions
- 3 Portable Power Solutions

4 Linear Regulators (LDOs)

- 4 Low- and Wide- V_{IN} LDOs
- 5 Automotive AEC-Q100 LDOs

6 Non-Isolated DC/DC Switching Regulators

- 6 Overview
- 7 Step-Down (Buck)
 - Single Channel
 - Multi-Channel
 - Buck Controllers
 - Processor V-Core Buck Controllers
 - Buck Charge Pumps
- 17 Step-Up (Boost)
- 20 Buck/Boost, Inverting or Split-Rail

22 Power Modules

- 22 Overview
- 23 Open-Frame Power Modules
- 24 QFN and MicroSiP™ Modules

26 Battery Management Products

- 26 Overview
- 26 Battery Charger ICs
- 29 Energy Harvesting & Solar Charging and Single-Cell Fuel Gauges
- 30 Multi-Cell Fuel Gauges, Battery Monitors and Peripherals
- 31 Battery and Charger Protection and Authentication Solutions

32 Power MOSFETs

- 32 Overview
- 33 N-Channel MOSFET Transistors
- 36 P-Channel MOSFET Transistors
- 37 Power MOSFET Modules

38 High-Voltage Power: AC/DC and Isolated DC/DC

- 38 MOSFET and IGBT Gate Drivers
 - Overview
 - Low-Side Drivers
 - Half-Bridge Drivers
 - Isolated Gate Drivers
 - Automotive-Grade Gate Drivers
- 44 Controllers and Converters
 - Overview
 - PWM and Resonant Controllers
 - Offline Converters and Synchronous Rectifier Controllers
- 50 Gallium Nitride (GaN) Solutions

53 Power Management Multi-Channel IC (PMIC) Solutions

55 LED Drivers

- 55 Overview
- 55 Automotive LED Drivers
 - Front Lighting
 - Rear Lighting
 - Other Signal and Convenience Lighting
 - Multi-Channel Indicator
- 60 RGB- and White-LED Drivers
- 61 Signage LED Display Drivers
- 62 General-Lighting LED Drivers
- 64 Flash LED Drivers

65 Display Power and Backlighting

- 65 LCD/OLED Display Power and Drivers
- 67 LED Backlighting

69 Supervisor and Reset ICs

71 Sequencers

72 Power Interface and Protection

- 72 Power Over Ethernet (PoE) Solutions
- 74 USB Power and Charging Port Controllers
- 78 Interface Protection

79 Power Switches

- 79 Overview
- 80 Load Switches, Power Muxes and eFuses
- 81 Hot-Swap Controllers
- 82 Ideal Diode/ORing Controllers, Smart High-Side Switches and Low-Side Switches

83 DDR Memory Power Solutions

84 Voltage References

85 Resources

- Device Index
- TI Worldwide Technical Support

Portable and Line Power Solutions

Line Power Solutions

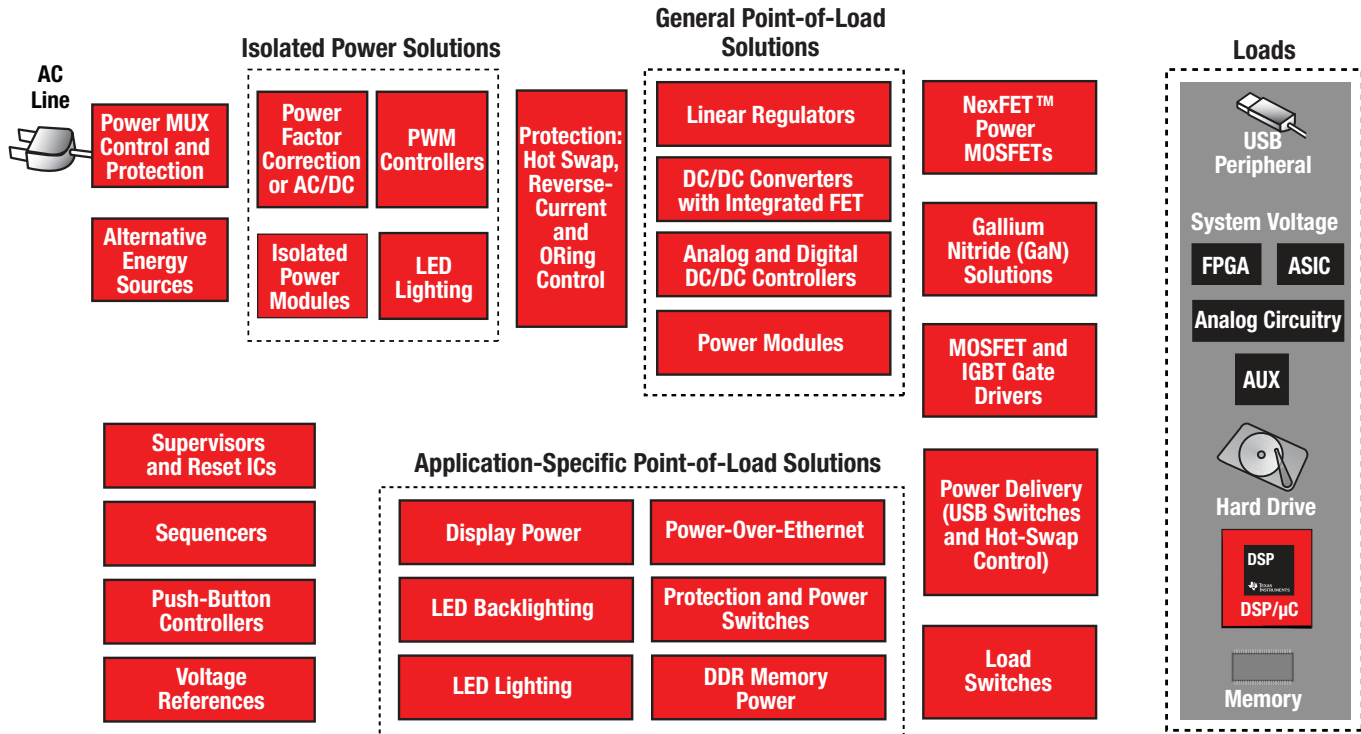

Portable Power Solutions

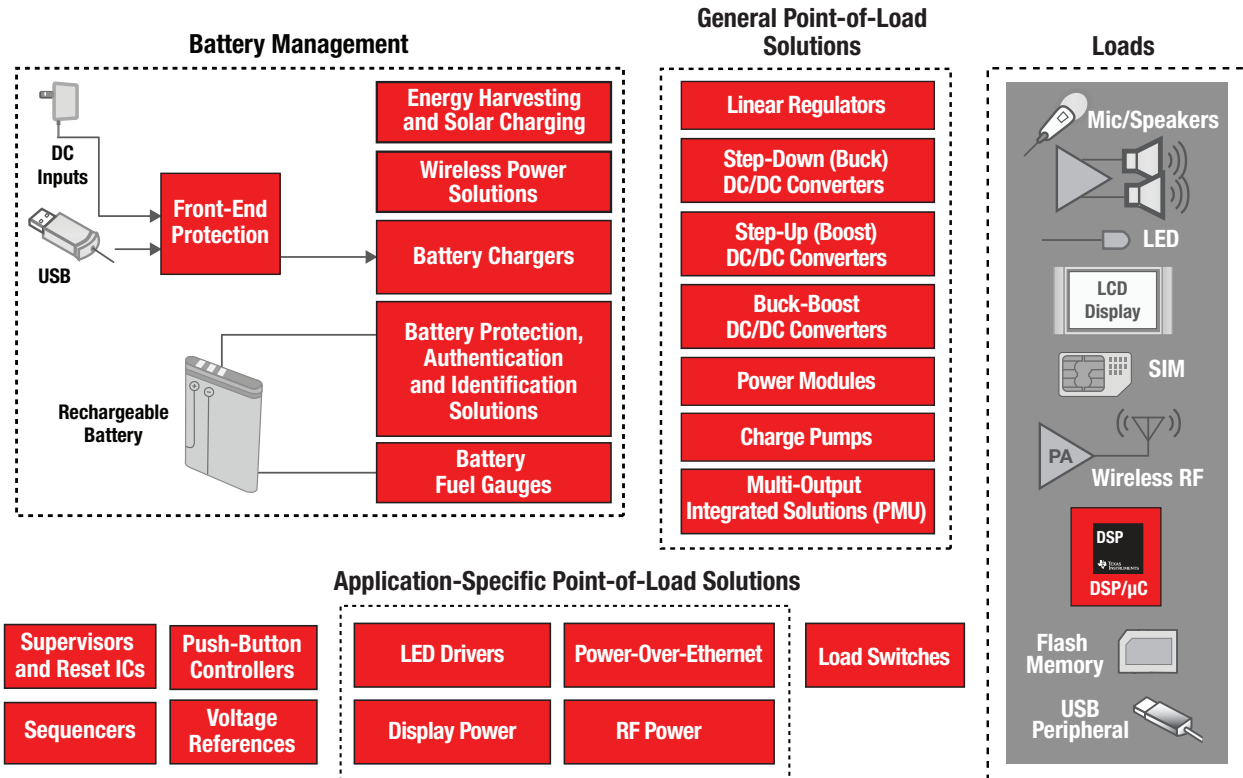

Linear Regulators (LDOs)

Overview and Selection Guide

Overview

Low-dropout linear regulators (LDOs) are a simple, effective way to regulate an output voltage powered from a higher input voltage. Texas Instruments (TI) has a broad portfolio of LDOs that feature small-size packaging, low quiescent current (low I_Q) to extend battery life, low-noise LDOs with high power-supply rejection ratio (PSRR), low intrinsic noise, high output current with fast transient response, and high-voltage LDOs for rugged automotive environments.

Reduce solution size: Use small-size, high-performance LDOs

The complexity and density of today's electronic designs equate to a limited amount of PCB space. To address the trend toward ever-smaller electronics, LDOs must deliver the same performance while consuming as little space as possible. TI offers many LDOs that address the high-performance requirements and tiny solution size.

Device	Regulated Outputs (#)	V_{IN} Range (V)	I_{OUT} (A)	Area (mm ²)	Price*
Low V_{IN}					
TPS7A05	1	1.4 to 5.5	200	0.42	0.18
LP5907	1	2.2 to 5.5	250	0.47	0.14
LP5910	1	1.3 to 3.3	300	0.49	0.14
TLV705	1	2 to 5.5	200	0.59	0.14
TPS7A10	1	0.6 to 3.6	300	0.88	0.30
TLV755P	1	1.44 to 5.5	500	1.00	0.19
TLV742P	1	2 to 5.5	200	1.00	0.09
TLV711	2	2 to 5.5	200	2.25	0.17
TLV757P	1	1.45 to 5.5	1000	1.00	0.26
Wide V_{IN}					
LM317L-N	1	4.2 to 40	100	2.34	0.21
TPS709	1	2.7 to 30	150	4.00	0.39
TPS715A	1	2.5 to 24	80	4.00	0.40

*Suggested resale price in U.S. dollars in quantities of 1,000.

New devices are listed in bold red.

Save power: Use low- I_Q LDOs

TI's low- I_Q LDOs can help save power across a variety of applications. By keeping quiescent current draw to a minimum, these LDOs extend battery life, manage standby power, and optimize battery backup systems.

Device	V_{IN} Range (V)	I_{OUT} (A)	I_Q (μ A)	Price*
Low V_{IN}				
TPS782	2.2 to 5.5	150	0.5	0.25
TPS781	2.2 to 5.5	150	0.5	0.34
TPS7A05	1.4 to 5.5	299	1	0.18
TPS706	2.7 to 6.5	150	1	0.23
TPS797	1.8 to 5.5	50	1	0.34
TPS7A10	0.6 to 3.6	300	5	0.30
Wide V_{IN}				
TPS709	2.7 to 30	150	1	0.39
TLV704	2.5 to 5	150	3	0.25
TPS7A16	3 to 60	100	5	1.39
TPS7A19	4 to 40	450	15	0.59

*Suggested resale price in U.S. dollars in quantities of 1,000.

New devices are listed in bold red.

Clean up your power supply: Use low-noise LDOs

TI's ultra-low-noise LDO solutions offer an easy and effective approach to powering the most sensitive loads. Low-noise LDOs eliminate voltage ripple and provide clean DC power to ensure the optimal signal integrity.

Device	Regulated Outputs (#)	V_{IN} Range (V)	I_{OUT} (A)	Noise (μ V _{RMS})	PSRR (dB)	Price*
Low V_{IN}						
TPS7A88	2	1.4 to 6.5	1000	3.8	48	1.80
TPS7A83A	1	1.1 to 6.5	2000	4.4	40	2.45
TPS7A92	1	1.4 to 6.5	2000	4.7	48	1.50
TPS7A90	1	1.4 to 6.5	500	4.7	48	0.60
LP5907	1	2.2 to 5.5	250	6.5	60	0.14
LP5912	1	1.6 to 6.5	500	12	40	0.40
TPS717	1	2.5 to 6.5	150	30	67	0.36
Wide V_{IN}						
TPS7A33	1	-36 to -3	1000	16	64	2.70
TPS7A30	1	-36 to -3	200	15	55	1.50
TPS7A39	2	-33 to -3.3, 3.3 to 33	150	15	56	2.88
TPS7A49	1	3 to 36	150	15	54	1.10
TPS7A47	1	3 to 36	1000	4	60	2.10
LP38798	1	3 to 20	800	5	65	1.30

*Suggested resale price in U.S. dollars in quantities of 1,000.

New devices are listed in bold red.

Robust LDOs with wide V_{IN} and current protection enhance system reliability

TI's wide input-voltage LDOs (up to 100 V) help manage large transient voltages for automation systems, appliances and HVAC applications. With additional high-performance features like fold-back current, reverse current, thermal robustness, and short-to-ground protection, wide- V_{IN} LDOs shelter any system from damaging situations.

Device	V_{IN} Range (V)	I_{OUT} (A)	Protection Features	Price*
Enhanced Power Protection				
TPS7A45	2.1 to 20	1500	Reverse current	1.30
TPS73801	2.2 to 20	1000	Reverse current & voltage	1.26
TPS709	2.7 to 30	150	Reverse current	0.39
TPS7A16	3 to 60	100	Under-voltage lockout	0.95
TPS7A4201	7 to 28	50	Reverse current	0.28
LM2936	5.5 to 60	50	Internal current limit, reverse polarity	0.62
Wide V_{IN} and Thermally Protected				
TPS7A19	4 to 40	450	Internal current limit	0.59
LP2985-N	2.2 to 16	150	Internal current limit	0.24
TPS7B69	4 to 40	150	Internal current limit	0.38
TLV760	4.2 to 30	100	Internal current limit	0.09
TPS7A4001	7 to 100	50	Internal current limit	1.05

*Suggested resale price in U.S. dollars

New devices are listed in bold red.

Linear Regulators (LDOs)

Selection Guide

Eliminate switching noise and achieve efficient, accurate regulation for FPGAs and processors with TI LDOs

In FPGAs and processors, switching noise can threaten performance. TI's LDOs achieve clean, accurate and efficient power for today's processors and FPGAs. The high-PSRR LDOs eliminate ripple, offer high output accuracy (1% max) and deliver low dropout of 250 mV and below. They also come in wide voltage ranges and small, robust packaging that work for many applications.

Device	Regulated Outputs (#)	V _{IN} Range (V)	I _{OUT} (A)	Power Supply Ripple Rejection (dB)	Accuracy (%)	Price*
TPS7A85A	1	1.1 to 6.5	4000	25	0.75	3.50
TPS74401	1	0.8 to 5.5	3000	50	1	2.50
TPS7A83A	1	1.1 to 6.5	2000	40	0.75	2.45
TPS7A91	1	1.4 to 6.5	1000	48	1	1.20
TLV757P	1	1.4 to 5.5	1000	45	1	0.26
TPS7A88	2	1.4 to 6.5	1000	48	1	1.80
TPS720	1	1.1 to 4.5	350	55	2	0.37

*Suggested resale price in U.S. dollars in quantities of 1,000.

New devices are listed in bold red.

Enhance your automotive power supply with high-performance AEC-Q100 LDOs

TI's AEC-Q100 LDOs optimize your automotive application with features such as low I_Q, low noise, high PSRR, and reverse-battery and current protection to provide a robust, clean power supply.

Device	Regulated Outputs (#)	V _{IN} Range (V)	I _{OUT} (mA)	Features	Package(s)	Automotive Grade	Price*
Low V_{IN} LDOs							
TPS7A52-Q1	1	1.1 to 6.5	2000	Low Noise/High PSRR, Enable	QFN	✓	2.65
TPS7A8101-Q1	1	2.2 to 6.5	1000	High PSRR, Enable	DFN	✓	1.18
TPS7A88-Q1	2	1.4 to 6.5	1000	Low Noise/High PSRR, Enable	QFN	✓	2.12
LP5912-Q1	1	1.6 to 6.5	500	Low Noise, Enable	DFN	✓	0.47
TPS720-Q1	1	1.1 to 4.5	350	Ultralow Dropout, Enable	DFN	✓	0.44
TLV733P-Q1	1	1.4 to 5.5	300	Enable	DFN	✓	0.20
TLV702-Q1	1	2 to 5.5	300	High PSRR, Enable	DFN, SOT23	✓	0.15
LP5907-Q1	1	2.2 to 5.5	250	Low Noise/High PSRR, Enable	SOT23	✓	0.17

Device	V _{IN} Range (V)	I _{OUT} (mA)	I _Q (μA)	Features	Automotive Grade	Price*
Off-Battery LDOs						
TPS7B82-Q1	3 to 40	300	3	Enable	✓	0.59
TPS7A16-Q1	3 to 60	100	5	Enable, Adj. PG Delay	✓	1.65
TPS7A66-Q1	4 to 40	150	12	Enable, Adj. PG Delay	✓	0.65
TPS7B69-Q1	4 to 40	150	15		✓	0.45
TPS7B68-Q1	4 to 40	500	19	Adj. Watchdog Timer, Adj. PG Delay/Threshold, Enable	✓	1.15
TPS7B63-Q1	4 to 40	300	19	Adj. Watchdog Timer, Adj. PG Delay/Threshold, Enable	✓	0.98
TPS798-Q1	3 to 50	50	40	Rev. Polarity Prot., Enable	✓	0.81

Device	Regulated Outputs (#)	V _{IN} Range (V)	I _{OUT} (mA)	Protection Features	Package(s)	Automotive Grade	Price*
Off-Board Power (Trackers and Antenna LDOs)							
TPS7B4253-Q1	1	4 to 40	300	Rev. Polarity, Short-to-Battery, Short-to-Ground, Therm. Shutdown	SO PowerPAD™	✓	0.85
TPS7B7701-Q1	1	4 to 40	300	Rev. Polarity, Short-to-Battery, Short-to-Ground, Therm. Shutdown	HTSSOP	✓	1.00
TPS7B7702-Q1	2	4 to 40	300	Rev. Polarity, Short-to-Battery, Short-to-Ground, Therm. Shutdown	HTSSOP	✓	1.75
TPS7B4254-Q1	1	4 to 40	150	Rev. Polarity, Short-to-Battery, Short-to-Ground, Therm. Shutdown	HTSSOP, SO PowerPAD	✓	0.70
TPS7B4250-Q1	1	4 to 40	50	Rev. Polarity, Short-to-Battery, Short-to-Ground, Therm. Shutdown	SOT-23	✓	0.40

*Suggested resale price in U.S. dollars in quantities of 1,000.

New devices are listed in bold red.

Non-Isolated DC/DC Switching Regulators

Overview

TI's large portfolio of non-isolated DC/DC point-of-load solutions address size, efficiency, performance or cost constraints. Our solutions range from discrete devices to integrated power solutions that contain magnetics within the IC package.

With operating voltages of up to 100 V, TI's wide- V_{IN} portfolio eliminates input protection components to reduce cost and solution size.

Step-Down DC/DC Converters — Integrated MOSFET technology has reached high levels of density over the past few years to provide higher efficiency in smaller packages. TI's DC/DC converters offer many compelling solutions up to 30 A.

Step-Up Boost Converters — The datasheet specifies the current limit of the integrated power MOSFET switches. A rough estimate for the actual output current achievable is a function of the duty cycle and can be estimated with the following formula:

$$I_{OUT} = 0.65 \times I_{Switch(min)} \times (V_{IN}/V_{OUT})$$

Buck-Boost Converters — A DC/DC converter must be able to regulate the output voltage at all possible input-voltage conditions, whether V_{IN} is higher or lower than V_{OUT} . TI's single-inductor buck-boost converters integrate four power MOSFETs on-chip to save space and to seamlessly transition in between the modes of operation.

Split-Rail Converters — Each member of the TPS6513x family of split-rail converters ($+V_{OUT1}/-V_{OUT2}$) creates regulated positive and negative supply voltages out of one input rail. This decreases BOM costs and space while providing best-in-class performance for industrial and automotive applications.

DC/DC Controllers — The output current is set by external MOSFETs, which allows the designer to optimize the efficiency and performance. Strong MOSFET drivers in TI's controllers can drive more external MOSFETs.

Charge Pumps — TI's family of low-voltage charge pumps provides a low-noise solution to boost the voltage without an inductor. Charge pumps achieve 90% peak efficiency and are useful for output currents under 300 mA.

Visit www.ti.com/power to find the latest point-of-load solutions by simply providing the voltages and output current of your system.

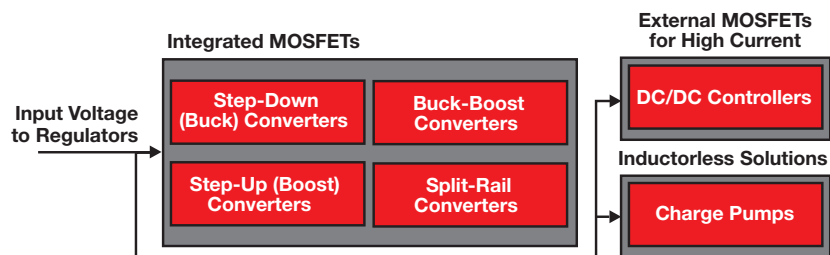

Step-Down DC/DC Converter Portfolio

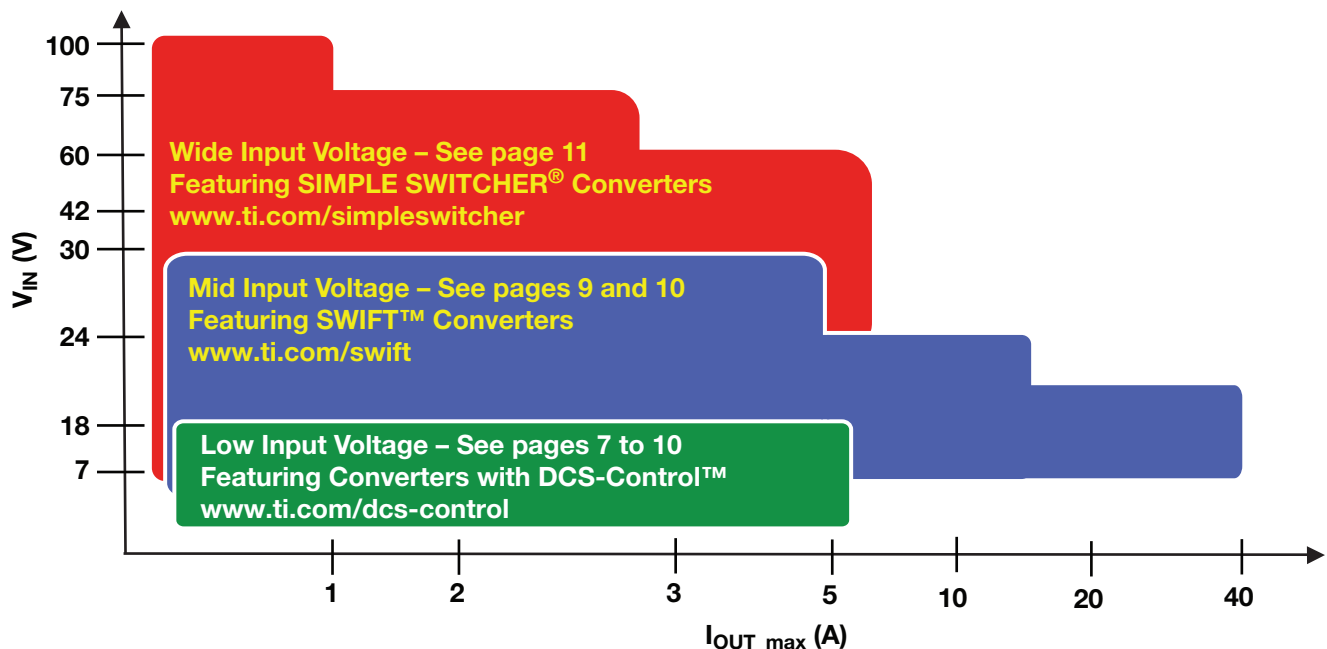

Non-Isolated DC/DC Switching Regulators

Step-Down (Buck)

Buck Converters, Single Channel

Device	I _{OUT} (A)	V _{IN} (V)	V _{OUT} (V) (Adj.)/Fixed	Switching Frequency (typ) (kHz)	Control Mode ¹	External Compensation	Synchronous Rectifier	Light-Load Efficiency	Power Good	Synch. to Ext. CLK Pin	Adjustable Soft Start	I _Q (typ) (µA)	Automotive Grade	Other Features	EVM	Package(s)	Price*
Low Input Voltage (<7 V_{IN} Max)																	
TPS62730	0.1	1.9 to 3.9	1.9/2.1/2.3	3000	DCS	✓	✓					25		Bypass switch; for BLE and RF4CE	✓	QFN	0.44
TPS62240	0.3	2 to 6	(0.6 to V _{IN})/1.2/1.8	2250	VM	✓						15		Forced PWM mode option	✓	TSOT-23, SON	0.42
TPS62740	0.3/0.4	2.2 to 5.5	1.8 to 3.3	3000	DCS	✓	✓	✓				0.36		Load switch; 4-pin Vselect	✓	WSON	0.68
TPS62743/431	0.3/0.4	2.2 to 5.5	1.2 to 3.3	3000	DCS	✓	✓					0.36		Smallest solution size	✓	WCSP8	0.72
TPS62746	0.3	2.2 to 5.5	1.2/1.8	1200	DCS	✓	✓					0.3		Integrated V _{IN} -switch for V _{batt} supervision	✓	WCSP8	0.68
TPS62748	0.3	2.2 to 5.5	1.2/1.8	1200	DCS	✓	✓					0.36		Integrated load switch	✓	WCSP8	0.68
LM3670	0.35	2.5 to 5.5	0.7 to 3.3	1000	VM	✓	✓					15			✓	SOT-23	0.36
TPS62619	0.35	2.3 to 5.5	1.2/1.3/1.5/1.8/2.15	6000	VM	✓	✓					31		0.4-mm solution height		WCSP	0.41
TPS62270	0.4	2 to 6	0.9/1.15/2.1/2.5/3.3	2250	VM	✓	✓					15		Vselect pin	✓	QFN	0.53
TPS62230	0.5	2.05 to 6	1.0 to 3.3	3000	VM	✓	✓					22	✓	Up to 90-dB PSRR, forced PWM mode option	✓	QFN	0.44
TPS62674	0.5	2.3 to 4.8	1.05/1.2/1.26/1.5/1.8	5500	VM	✓	✓					17		Spread spectrum	✓	WCSP	0.46
TPS62690	0.5	2.3 to 4.8	2.2/2.8/2.85	4000	VM	✓	✓					19		Spread spectrum	✓	WCSP	0.49
LM3671	0.6	2.7 to 5.5	1.1 to 3.3	2000	VM	✓	✓					16			✓	SOT-23, QFN	0.48
TPS62260	0.6	2 to 6	(0.6 to V _{IN})/1.2/1.8	2250	VM	✓	✓					15	✓	Forced PWM mode option	✓	SOT-23, QFN	0.48
TPS62620	0.6	2.3 to 5.5	1.2/1.225/1.5/1.8/1.82	6000	VM	✓	✓					31		Thermal shutdown protection	✓	WCSP	0.49
LM2830	1	3 to 5.5	(0.6 to 4.5)	1600, 3000	CM		✓					3300	✓	Enable		SOT-23, WSON	0.65
LM3691	1	2.3 to 5.5	0.75 to 3.3	4000	VM	✓	✓					64		Enable, soft start	✓	CSP	0.63
LMR10510	1	3 to 5.5	(0.6 to 4.5)	1600, 3000	CM							3300		Enable, soft start		LLP-6, SOT-23	0.30
TLV62568	1	2.5 to 5.5	(0.6 to V _{IN})	1500	CM	✓	✓	✓				35		SOT563 pkg 65% smaller than SOT23	✓	SOT-23, SOT563	0.38
TPS62801	1	1.8 to 5.5	(0.4 to 3.3)	4000	DCS	✓	✓					3		Ultra-small solution size, sel. Vout	✓	WCSP	0.70
TPS62821	1	2.4 to 5.5	(0.6 to 4.0)	2500	DCS	✓	✓	✓				5		1% accuracy over full temp	✓	QFN (1.5x2 mm)	0.55
TPS62290	1	2.3 to 6	(0.6 to V _{IN})/1.8/3.3	2250	VM	✓	✓					15	✓	Forced PWM mode option	✓	QFN	0.64
TPS62660	1	2.3 to 5.5	1.2/1.8	6000	VM	✓	✓					31		Active cap discharge	✓	WCSP	0.63
LM3281	1.2	3 to 5.5	3.3	6000	VM							15		Soft start, analog bypass	✓	CSP	0.30
TLV62080	1.2	2.5 to 5.5	(0.5 to 4.0)	2000	DCS	✓	✓	✓				30		Output discharge	✓	QFN	0.45
TPS62080	1.2	2.3 to 6	(0.5 to 4.0)/1.8/3.3	2000	DCS	✓	✓	✓				6		Snooze mode, active discharge	✓	SON	0.63
TPS62750	1.3	2.9 to 6	(0.8 to 0.85 × V _{IN})	2250	VM	✓	✓					780		Powered by USB; programmable input-current limit	✓	SON	0.72
LM2831	1.5	3 to 5.5	(0.6 to 4.5)	550, 1600, 3000			✓					2800			✓	SOT-23, WSON	0.75
LMR10515	1.5	3 to 5.5	(0.6 to 4.5)	1600, 3000	CM							3300		Enable, soft start		LLP-6, SOT-23	0.52
TPS62510	1.5	1.8 to 3.8	(0.6 to V _{IN})	1500	VM	✓	✓	✓	✓			22		Forced PWM option, output-voltage tracking	✓	QFN	0.73
TPS62060	1.6	2.3 to 6	(0.6 to V _{IN})/1.8/3.3	3000	VM	✓	✓					18		Output discharge	✓	QFN (2x2 mm)	0.73
LM2832	2	3 to 5.5	(0.6 to 4.5)	550, 1600, 3000	CM		✓					2800			✓	WSON, MSOP	0.80
LM2852	2	2.85 to 5.5	(0.8 to 3.3)	500, 1500	VM	✓						850			✓	HTSSOP	1.58
LMR10520	2	3 to 5.5	(0.6 to 4.5)	1600, 3000	CM							3300		Enable, soft start		LLP-6	0.55
TLV62084A	2	2.7 to 5.5	(0.5 to 4.0)	2000	DCS	✓	✓	✓				30		Pin-to-pin to TLV62080 (1.2 A)	✓	SON	0.58
TLV62569	2	2.5 to 5.5	(0.6 to V _{IN})	1500	CM	✓	✓	✓				35		SOT563 pkg 65% smaller than SOT23	✓	SOT-23, SOT563	0.44
TPS54218	2	2.95 to 6	(0.8 to 4.5)	200 to 2000	CM	✓	✓	✓	✓	✓		350		Enable	✓	16 QFN (3x3 mm)	0.80
TPS57112-Q1	2	2.95 to 6	(0.8 to 4.5)	200 to 2000	CM	✓	✓	✓	✓	✓		515	✓	Enable		16 WQFN (3x3 mm)	0.85
TPS62065	2	2.3 to 6	(0.6 to V _{IN})	3000	VM	✓	✓					18	✓	Output discharge	✓	2x2 QFN	0.76
TPS62097	2	2.5 to 6	(0.8 to V _{IN})	1500-2500	DCS	✓	✓	✓		✓		17	✓	Selectable freq., tracking, forced PWM mode option	✓	QFN	0.74
TPS62822	2	2.4 to 5.5	(0.6 to 4.0)	2500	DCS	✓	✓	✓				5		1% accuracy over full temp	✓	QFN (1.5x2 mm)	0.65
TPS62825	2	2.4 to 5.5	(0.6 to 4.0)	2500	DCS	✓	✓	✓				5		1% accuracy over full temp	✓	QFN (1.5x1.5 mm)	0.52
TPS62826	3	2.4 to 5.5	(0.6 to 4.0)	2500	DCS	✓	✓	✓				5		1% accuracy over full temp	✓	QFN (1.5x1.5 mm)	0.52
LM20123/33/43	3	2.95 to 5.5	(0.8 to 5)	250 to 1500	CM	✓	✓	✓	✓	✓		3500			✓	16 eTSSOP	1.36
LM2833	3	3 to 5.5	(0.6 to 4.5)	1500, 3000	CM		✓					3200			✓	MSOP, WSON	0.90

¹VM = voltage mode, CM = current mode, COT = constant on time, DCS = direct control with seamless transition into power-save mode.

*Suggested resale price in U.S. dollars in quantities of 1,000.

New devices are listed in bold red.

Non-Isolated DC/DC Switching Regulators

Step-Down (Buck)

Buck Converters, Single Channel (Continued)

Device	I _{OUT} (A)	V _{IN} (V)	V _{OUT} (V) (Adj./Fixed)	Switching Frequency (typ) (kHz)	Control Mode ¹	External Compensation	Synchronous Rectifier	Light-Load Efficiency	Power Good	Synch. to Ext. CLK Pin	Adjustable Soft Start	I _Q (typ) (μA)	Automotive Grade	Other Features	EVM	Package(s)	Price*
Low Input Voltage (<7 V_{IN} Max) (Continued)																	
LM2853	3	3 to 5.5	(0.8 to 3.3)	550	VM	✓	✓					850			✓	HTSSOP	1.84
TLV62085	3	2.5 to 6	(0.8 to 6.0)	2400	DCS	✓	✓	✓	✓			17		Short circuit protection	✓	QFN (2x2 mm)	0.67
TLV62090	3	2.5 to 5.5	(0.8 to V _{IN})	1400	DCS	✓	✓	✓	✓	✓		20		Output discharge	✓	QFN (3x3 mm)	0.67
TLV62585	3	2.5 to 5.5	(0.6 to V _{IN})	1500	CM	✓	✓	✓	✓			35		Short circuit protection	✓	SOT563, QFN (2x2 mm)	0.55
TPS53311	3	2.9 to 6	(0.6 to 4.2)	1000	VM	✓	✓	✓	✓			320		Enable, pre-biased, interleaving, output discharge	✓	16 QFN (3x3 mm)	2.15
TPS54318	3	2.95 to 6	(0.8 to 4.5)	200 to 2000	CM	✓	✓		✓	✓	✓	350		Enable, pre-biased	✓	16 QFN (3x3 mm)	1.00
TPS54319	3	2.95 to 6	(0.8 to 4.5)	300 to 2000	CM	✓	✓		✓	✓	✓	360		Enable, frequency tracking	✓	16 QFN (3x3 mm)	0.65
TPS54388-Q1	3	2.95 to 6	(0.8 to 4.5)	200 to 2000	CM	✓	✓		✓	✓	✓	515	✓	Enable	✓	16 WQFN (3x3 mm)	1.15
TPS62085	3	2.5 to 6	(0.8 to V _{IN})/1.8/3.3	2400	DCS	✓	✓	✓	✓			17		Short circuit protection	✓	QFN (2x2 mm)	0.82
TPS62088	3	2.4 to 5.5	(0.6 to 4.0)/1.2/1.8/3.3	4000	DCS	✓	✓	✓	✓			5		Smallest solution size with 240-nH inductor	✓	WCSP	0.70
TPS62090	3	2 to 5.5	(0.8 to V _{IN})/1.8/2.5/3.3	2800/1400	DCS	✓	✓	✓	✓	✓		20	✓	Frequency select	✓	QFN (3x3 mm)	0.82
TPS62360	3	2.5 to 5.5	(0.5 to 1.77)	2500	DCS	✓	✓					56		I ² C interface, differential sense	✓	WCSP	0.72
TPS62823	3	2.4 to 5.5	(0.6 to 4.0)	2500	DCS	✓	✓	✓	✓			5		1% accuracy over full temp	✓	QFN (1.5x2 mm)	0.75
TPS62826	3	2.4 to 5.5	(0.6 to 4.0)	2500	DCS	✓	✓	✓	✓			5		1% accuracy over full temp	✓	QFN (1.5x1.5 mm)	0.63
LM1770	4	2.8 to 5.5	(0.8 to 4.5)	500 to 2000		✓						400			✓	SOT-23	0.70
LM20124/34/44/54	4	2.95 to 5.5	(0.8 to 5)	250 to 1500	CM	✓	✓		✓	✓	✓	3500			✓	16 eTSSOP	1.50
LM2854	4	2.95 to 5.5	(0.8 to 5)	500, 1000	VM	✓						1700			✓	HTSSOP	2.21
TLV62095	4	2.5 to 5.5	(0.8 to V _{IN})	1400	DCS	✓	✓	✓	✓	✓		20		Output discharge, tracking	✓	QFN (3x3 mm)	0.70
TPS54478	4	2.95 to 6	(0.6 to 4.5)	200 to 2000	CM	✓	✓		✓	✓	✓	350		Enable, track, pre-biased	✓	16 QFN (3x3 mm)	1.30
TPS57114-Q1	4	2.95 to 6	(0.8 to 4.5)	200 to 2000	CM	✓	✓		✓	✓	✓	515	✓	Enable	✓	16 WQFN (3x3 mm)	1.48
TPS62095	4	2.5 to 5.5	(0.8 to V _{IN})	1400	DCS	✓	✓	✓	✓	✓		20		Output discharge, tracking	✓	QFN (3x3 mm)	0.97
TPS62366	4	2.5 to 5.5	(0.5 to 1.77)	2500	DCS	✓	✓					56		I ² C interface, different. sense	✓	WCSP	0.78
LM20125/45	5	2.95 to 5.5	(0.8 to 5)	250 to 1500	CM	✓	✓		✓	✓	✓	3500			✓	16 eTSSOP	1.56
TPS54519	5	2.95 to 6	(0.6 to 4.5)	200 to 2000	CM	✓	✓		✓	✓	✓	455		Enable, tracking, UVLO adjustable	✓	16 QFN (3x3 mm)	0.85
TPS53316	5	2.95 to 6	(0.6 to 5.5)	750/1100/2000	VM	✓	✓	✓	✓			320		Enable, pre-biased, output discharge	✓	16 QFN (3x3 mm)	2.55
LM1771	6	2.8 to 5.5	(0.8 to 4.5)	500 to 2000		✓						400			✓	VSSOP, WSON	0.75
LM20136/46	6	2.95 to 5.5	(0.8 to 5)	250 to 1500	CM	✓	✓		✓	✓	✓	3500			✓	16 eTSSOP	1.65
TPS54618-Q1	6	2.95 to 6	(0.8 to 4.5)	300 to 2000	CM	✓		✓	✓	✓	✓	250	✓	Enable, track, pre-biased	✓	16 QFN (3x3 mm)	2.01
TPS54678	6	2.95 to 6	(0.6 to 4.5)	200 to 2000	CM	✓		✓	✓	✓	✓	250		Enable, track, pre-biased	✓	16 QFN (3x3 mm)	1.70
TPS62480	6	2.4 to 5.5	(0.6 to 5.5)	2500	CM	✓	✓	✓	✓	✓	✓	23		Forced PWM option, Vselect pin	✓	QFN (3x2.5 mm)	1.15
TPS54719	7	2.95 to 6	(0.6 to 4.5)	200 to 2000	CM	✓	✓		✓	✓	✓	455		Enable, tracking, UVLO adjustable	✓	160QFN (3x3 mm)	1.30
TPS54917	9	3 to 4	(0.9 to 2.5)	280 to 1600	VM	✓	✓		✓	✓	✓	9800		Enable	✓	34 QFN (3.5x7 mm)	3.30
LM21212-1	12	2.95 to 5.5	(0.6 to 5.5)	1000	VM	✓	✓		✓	✓	✓	1500		Enable, soft start	✓	HTSSOP	3.30
LM21212-2	12	2.95 to 5.5	(0.6 to 5.5)	300 to 1500	VM	✓	✓		✓	✓	✓	1500		Enable, soft start	✓	HTSSOP	3.30
LM21215	15	2.95 to 5.5	(0.6 to 5.5)	500	VM	✓	✓		✓	✓	✓	1500		Enable, soft start	✓	HTSSOP	3.55
LM21215A	15	2.95 to 5.5	(0.6 to 5.5)	300 to 1500		✓	✓		✓	✓	✓	1500		Enable, soft start	✓	HTSSOP	3.55
LP8758-B0	16	2.5 to 5.5	1.1V/Adj.	3000	CM				✓			6		I ² C interface, enable, differential sense, spread-spectrum	✓	CSP	2.25

¹VM = voltage mode, CM = current mode, COT = constant on time, DCS = direct control with seamless transition into power-save mode.
*Suggested resale price in U.S. dollars in quantities of 1,000.

New devices are listed in bold red.

Non-Isolated DC/DC Switching Regulators

Step-Down (Buck)

Buck Converters, Single Channel (Continued)

Device	I _{OUT} (A)	V _{IN} (V)	V _{OUT} (V) (Adj.)/Fixed	Switching Frequency (typ) (kHz)	Control Mode ¹	External Compensation	Synchronous Rectifier	Light-Load Efficiency	Power Good	Synch. to Ext. CLK Pin	Adjustable Soft Start	I _Q (typ) (μA)	Automotive Grade	Other Features	EVM	Package(s)	Price*
Mid Input Voltage (7 to 30 V_{IN} Max)																	
TPS62120	0.075	2 to 15	(1.2 to 5.5)	800	DCS	✓	✓	✓				11		Ext. UVLO hysteresis	✓	SOT-23, QFN	0.47
TPS62125	0.3	3 to 17	(1.2 to 10)	1000	DCS	✓	✓	✓				5		Program. EN threshold and hysteresis	✓	QFN	0.50
TPS62745	0.3	3.3 to 10	Select. (1.8 to 3.3)	2500	DCS	✓	✓	✓				0.4		Integrated discharge function, integrated V _{IN} switch	✓	WSON	0.79
TPS62170	0.5	3 to 17	(0.9 to 6)/1.8/3.3/5	2500	DCS	✓	✓	✓				17	✓	Integrated discharge function	✓	QFN	0.49
TPS560200	0.5	4.5 to 17	0.8 to 6.5	600	D-CAP2™	✓	✓					60	✓	Enable, UVLO	✓	SOT23-5	0.32
TPS62175	0.5	4.75 to 28	(1 to 6)	1000	DCS	✓	✓	✓				4.8		Active output discharge, UVLO	✓	10 WSON (2x3 mm)	0.53
LM2736	0.75	3 to 18	(1.25 to 16)	550, 1600	CM							1500			✓	6 SOT	0.65
LMR12007	0.75	3 to 18	1.25 to 16	550, 1600								1500		Enable, soft start		TSOT23	0.75
TPS62050	0.8	2.7 to 10	(0.7 to 6)/1.5/1.8/3.3	850	VM	✓	✓	✓	✓			12		Low-battery indicator	✓	MSOP	0.83
LM2734	1	3 to 20	(0.8 to 18)	550 to 1600	CM							2100			✓	6 TSOP	0.95
LMR12010	1	3 to 20	0.8 to 17	1600, 3000	CM							1500		Enable, soft start		TSOT-23	0.79
TLV62150	1	4 to 17	(0.9 to 5)	2250	DCS	✓	✓	✓		✓		19		Tracking, voltage and frequency select	✓	QFN	0.58
TPS62150	1	3 to 17	(0.9 to 6)/1.8/3.3/5	2500/1250	DCS	✓	✓	✓		✓		17	✓	Tracking, voltage and frequency select, 40 dB PSRR	✓	QFN	0.74
TPS62160	1	3 to 17	(0.9 to 6)/1.8/3.3/5	2500/1250	DCS	✓	✓	✓				17	✓	Tracking, voltage and frequency select	✓	8 MSOP/WSON (2x2 mm)	0.70
TPS561201	1	4.5 to 17	0.76 to 7	580	D-CAP2	✓	✓					380/590		Enable, UVLO, OVP	✓	SOT23-6	0.25
TPS561208	1	4.5 to 17	0.76 to 7	580	D-CAP2	✓						380/590		Enable, UVLO, OVP, FPWM	✓	SOT23-6	0.25
LM2651	1.5	4 to 14	(3.3 to 13)/1.8/2.5/3.3	300		✓	✓	✓		✓					✓	16 TSSOP	1.47
LM2653	1.5	4 to 14	(1.5 to 5)	300		✓	✓	✓		✓					✓	16 TSSOP	1.50
LM27341	1.5	3 to 20	(1 to 18)	2000						✓		2400			✓	10 WSON, 10 MSOP	1.10
LM2738	1.5	3 to 20	(0.8 to 18)	550, 1600								16			✓	8 WSON, 8 MSOP	1.20
TPSM84203/05/12	1.5	4.5 to 28	3.3/ 5.0/ 12	400	CM	✓	✓							EMI tested, light load efficiency, spread spectrum	✓	TO-220	3.00
TPS5402	1.5	3.5 to 28	(0.8 to 26)	50 to 1100	CM	✓	✓	✓		✓		100		Light load efficiency, spread spectrum, OCP	✓	8 SOIC	0.60
TPS5403/05	1.7/2	4.5/6.5 to 28	3.3/5	50 to 1100	CM	✓	✓			✓		100		Light load efficiency, spread spectrum, OCP, fixed 3.3/5-V output	✓	8 SOIC	0.60
LM27342	2	3 to 20	(1 to 18)	2000						✓		2400			✓	10 WSON, 10 MSOP	1.20
TPS562200/09	2	4.5 to 17	(0.76 to 7)	650	D-CAP2	✓	✓/-					230		Enable, light load efficiency, OVP, UVLO	✓	SOT-23	0.40
TPS562201/08	2	4.5 to 17	(0.76 to 7)	580	D-CAP2	✓	✓/-					400		Enable, UVLO, OVP, FPWM (TPS562208)	✓	SOT-23	0.35
TPS562210A	2	4.5 to 17	0.76 to 7	650	D-CAP2	✓	✓	✓		✓		190		Enable, UVLO, OVP		DDF(8)	0.45
TPS562219A	2	4.5 to 17	0.76 to 7	650	D-CAP2	✓	✓	✓		✓		190		Enable, UVLO, OVP		DDF(8)	0.45
TPS62140	2	3 to 17	(0.9 to 6)	2500/1250	DCS	✓	✓	✓		✓		17		Tracking, voltage and frequency select, 40 dB PSRR	✓	16 QFN (3x3 mm)	0.81
TPS62147/148	2	3 to 17	(0.8 to 12)	2500/1000	DCS	✓	✓	✓		✓		18		Forced PWM option, 1% output accuracy	✓	QFN (3x2 mm)	0.81
TPS54239/239E	2	4.5 to 23	(0.76 to 7)	600	D-CAP2	✓	✓/-			✓		600		Enable, pre-biased soft start	✓	8 HSOIC	0.60
TPS54231/2/3	2	3.5 to 28	(0.8 to 25)	570/1000/300		✓	✓			✓		75	✓	Enable, UVLO adj., OVP, Q-grade (TPS54233)	✓	8 SOIC	0.55
TPS54202	2	4.5 to 28	0.6 to 26	500	CM	✓	✓					45		Enable, pre-bias start-up, UVLO adj., spread spectrum	✓	SOT-23	0.65
TPS54202H	2	4.5 to 28	0.6 to 26	500	CM	✓	✓					45		Enable, pre-bias start-up, UVLO adj.	✓	SOT-23	0.65
LM2655	2.5	4 to 14	(3.3 to 13)/3.3	300		✓	✓	✓		✓					✓	16 TSSOP	1.63
LM2650	3	4.5 to 18	(1.5 to 16)	300		✓	✓	✓		✓					✓	20 TSSOP	3.62
TLV62130A	3	3 to 17	(0.9 to 5.0)	2500/1250	DCS	✓	✓	✓		✓		19		Tracking, voltage and frequency select	✓	QFN	0.68
TPS54320	3	4.5 to 17	(0.8 to 15)	200 to 1200	CM	✓	✓		✓	✓		600		Enable, track, pre-biased	✓	14 QFN	1.70
TPS563200/09	3	4.5 to 17	(0.76 to 7)	650	D-CAP2	✓	✓/-					190		Enable, pre-biased output voltage, OVP, UVLO	✓	SOT-23	0.81/0.70
TPS563201/08	3	4.5 to 17	(0.76 to 7)	580	D-CAP2	✓	✓/-					400		Enable, UVLO, OVP, FPWM (TPS563208)	✓	SOT-23	0.45/0.45
TPS563210A	3	4.5 to 17	0.76 to 7	650	D-CAP2	✓	✓	✓		✓		190		Enable, UVLO, OVP	✓	DDF(8)	0.55

¹VM = voltage mode, CM = current mode, COT = constant on time, FF = feed forward, DCS = direct control with seamless transition into power-save mode.

*Suggested resale price in U.S. dollars in quantities of 1,000.

New devices are listed in bold red.

Non-Isolated DC/DC Switching Regulators

Step-Down (Buck)

Buck Converters, Single Channel (Continued)

Device	I _{OUT} (A)	V _{IN} (V)	V _{OUT} (V) (Adj./Fixed)	Switching Frequency (typ) (kHz)	Control Mode ¹	External Compensation	Synchronous Rectifier	Light-Load Efficiency	Power Good	Synch. to Ext. CLK Pin	Adjustable Soft Start	I _Q (typ) (μA)	Automotive Grade	Other Features	EVM	Package(s)	Price*
Mid Input Voltage (7 to 30 V_{IN} Max) (Continued)																	
TPS563219A	3	4.5 to 17	0.76 to 7	650	D-CAP2	✓	✓	✓	✓	✓	✓	190		Enable, UVLO, OVP	✓	DDF(8)	0.55
TPS54339/339E	3	4.5 to 23	(0.76 to 7)	600	D-CAP2	✓	-/✓	✓	✓	✓	✓	850		Enable, pre-biased soft start	✓	8 HSOIC	0.70
TPS54331	3	3.5 to 28	(0.8 to 25)	570	CM	✓	✓	✓	✓	✓	✓	110	✓	Enable, light load efficiency, UVLO adj.	✓	8 SOIC	0.65
TPS54302/08	3	4.5 to 28	0.6 to 26	400/350	CM	✓	✓	✓	✓	✓	✓	45		Enable, pre-bias start-up, UVLO adj.	✓	SOT-23	0.75/0.60
TPS54335A	3	4.5 to 28	0.8 to 25	50 to 1500	CM	✓	✓	✓	✓	✓	✓	310		Enable, UVLO adj.	✓	SO PowerPAD™ (8), WSON (10)	0.85
TPS54335-1A/-2A	3	4.5 to 28	0.8 to 25	50 to 1500	CM	✓	✓	✓	✓	✓	✓	310		Enable, UVLO adj.	✓	VSON (10)	0.90
TPS54336A	3	4.5 to 28	0.8 to 25	340	CM	✓	✓	✓	✓	✓	✓	310		Enable, UVLO adj.	✓	SO PowerPAD (8), WSON(10)	0.85
TPS62130A	3	3 to 17	(0.9 to 6)/1.8/3.3/5	2500/1250	DCS	✓	✓	✓	✓	✓	✓	17	✓	Tracking, voltage and frequency select, 40 dB PSRR	✓	QFN	0.88
TPS54332	3.5	3.5 to 28	(0.8 to 25)	1000	CM	✓	✓	✓	✓	✓	✓	82		Enable, light load efficiency, UVLO adj.	✓	8 HSOIC	0.65
TPS54424	4	4.5 to 17	(0.6 to 12)	200 to 1600	CM	✓	✓	✓	✓	✓	✓	580		EN, 0.85% Vref accuracy, pre-biased	✓	3.5x3.5 mm HotRod™	1.50
TPS62135/136	4	3 to 17	(0.8 to 12)	2500/1250	DCS	✓	✓	✓	✓	✓	✓	18		Forced PWM opt., 1% output accuracy	✓	QFN (3x2 mm)	0.88
TPS564201/08	4	4.5 to 17	0.76 to 7	580	D-CAP2	✓	✓/-	✓	✓	✓	✓	400/640		Enable, UVLO, OVP	✓	SOT23-6	0.65
TPS54427/8	4	4.5 to 18	(0.76 to 7)	700	D-CAP2	✓	-/✓	✓	✓	✓	✓	950		Enable, pre-biased soft start	✓	8 HSOIC, 10 SON	0.75/0.75
TPS56428	4	4.5 to 18	(0.6 to 5.5)	650	D-CAP2	✓	✓	✓	✓	✓	✓	250		Enable, pre-bias output	✓	8 HSOIC	0.80
LM21305	5	3 to 18	0.6	300 to 1500	CM	✓	✓	✓	✓	✓	✓	9000			✓	28 LLP	2.50
TPS54521	5	4.5 to 17	(0.8 to 15)	200 to 900	CM	✓	✓	✓	✓	✓	✓	600		Enable, pre-bias start-up, tracking	✓	QFN-14	0.95
TPS56520	5	4.5 to 17	(0.6 to 1.87)	500	D-CAP2	✓	✓	✓	✓	✓	✓	920		Adjustable current limit, dynamic voltage scaling, enable, pre-bias start-up, voltage margining	✓	20 HTSSOP	1.30
TPS56528	5	4.5 to 18	(0.76 to 5.5)	650	D-CAP2	✓	✓	✓	✓	✓	✓	250		Enable, pre-biased soft start	✓	8 HSOIC	0.95
TPS54527/8	5	4.5 to 18	(0.76 to 6)	700	D-CAP2	✓	-/✓	✓	✓	✓	✓	900		Enable, pre-biased soft start	✓	8 HSOIC	0.95
TPS54531	5	3.5 to 28	(0.8 to 25)	570	CM	✓	✓	✓	✓	✓	✓	110		Enable, UVLO adj., OVP, thermal shutdown	✓	8 SOIC	0.75
TPS565201/8	5	4.5 to 17	0.76 to 7	580	D-CAP2	✓	✓/-	✓	✓	✓	✓	320/590		Enable, UVLO, OVP	✓	SOT23-6	0.80
TPS53313	6	4.5 to 16	(0.6 to 10)	250 to 1500	VM	✓	✓	✓	✓	✓	✓	320		EN, ILIM, output discharge, pre-biased	✓	16 QFN (4x4 mm)	2.60
TPS54622	6	4.5 to 17	0.6 to 16	200 to 1600	CM	✓	✓	✓	✓	✓	✓	2		Enable, track, pre-biased	✓	14 QFN (3.5x3.5 mm)	1.90
TPS62180	6	4 to 15	(0.9 to 6)/3.3	2000	CM	✓	✓	✓	✓	✓	✓	28		Smallest 6-A buck solution	✓	DSBGA	1.26
TPS62184	6	4.0 to 17	(0.9 to 6)	2000	CM	✓	✓	✓	✓	✓	✓	28		Smallest 5-A buck solution	✓	DSBGA	1.26
TPS54627/8	6	4.5 to 18	(0.76 to 5.5)	650	D-CAP2	✓	-/✓	✓	✓	✓	✓	950		Enable, pre-biased soft start	✓	8 HSOIC	1.05
TPS56628	6	4.5 to 18	(0.76 to 5.5)	700	D-CAP2	✓	✓	✓	✓	✓	✓	950		Enable, pre-biased soft start	✓	8 HSOIC	1.05
TPS56720	7	4.5 to 17	(0.6 to 1.87)	500	D-CAP2	✓	✓	✓	✓	✓	✓	920		Adjustable current limit, dynamic voltage scaling, enable, pre-bias start-up, voltage margining	✓	20 HTSSOP	1.80
TPS54821	8	4.5 to 17	(0.6 to 15)	200 to 1600	CM	✓	✓	✓	✓	✓	✓	600		Enable, pre-bias start-up, tracking	✓	14 QFN	1.40
TPS54824	8	4.5 to 17	(0.6 to 12)	200 to 1600	CM	✓	✓	✓	✓	✓	✓	580		EN, 0.85% Vref accuracy, pre-biased	✓	3.5x3.5 mm HotRod	2.00
TPS568215/2150A	8	4.5 to 17	0.6 to 5.5	400, 800, 1200	D-CAP3™	✓	✓	✓	✓	✓	✓	600		Adjustable current limit, enable, pre-bias start-up, out of audio	✓	QFN-18	1.50/1.60
TPS51363	8	3 to 22	(0.6 to 2)	400 to 800	D-CAP2	✓	✓	✓	✓	✓	✓	560		Enable, output discharge	✓	28 QFN	2.10
TPS53513	8	4.5 to 18	0.6 to 5.5	250 to 1000	D-CAP3	✓	✓	✓	✓	✓	✓	1350		Enable, pre-biased and ILIM	✓	28 QFN (3.5x4.5 mm)	2.55
TPS56920	9	4.5 to 17	(0.6 to 1.87)	500	D-CAP2	✓	✓	✓	✓	✓	✓	920		Adjustable current limit, dynamic voltage scaling, enable, pre-bias start-up, voltage margining	✓	20 HTSSOP	1.70
TPS51362	10	3.0 to 22	(0.6 to 2)	800	D-CAP2	✓	✓	✓	✓	✓	✓	100		Enable, light load efficiency, output discharge	✓	28 QFN	2.30
TPS54020	10	4.5 to 17	0.6 to 5.0	200 to 1200	CM	✓	✓	✓	✓	✓	✓	600		Enable, track, pre-biased, 180° out of phase, ILIM	✓	15 QFN (3.5x3.5 mm)	3.45
TPS54A20	10	8 to 17	0.5 to 2.0	4000 to 10000	COT	✓	✓	✓	✓	✓	✓	5000		Enable, pre-biased, ILIM 2 phase 180° out of phase	✓	4x3.5 mm HotRod	3.25

¹VM = voltage mode, CM = current mode, COT = constant on time, FF = feed forward, DCS = direct control with seamless transition into power-save mode.

*Suggested resale price in U.S. dollars in quantities of 1,000.

New devices are listed in bold red.

Non-Isolated DC/DC Switching Regulators

Step-Down (Buck)

Buck Converters, Single Channel (Continued)

Device	I _{OUT} (A)	V _{IN} (V)	V _{OUT} (V) (Adj.)/Fixed	Switching Frequency (typ) (kHz)	Control Mode ¹	External Compensation	Synchronous Rectifier	Light-Load Efficiency	Power Good	Synch. to Ext. CLK Pin	Adjustable Soft Start	I _Q (typ) (μA)	Automotive Grade	Other Features	EVM	Package(s)	Price*
Mid Input Voltage (7 to 30 V_{IN} Max) (Continued)																	
TPS56C20	12	4.5 to 17	(0.6 to 1.87)	500	D-CAP2		✓	✓	✓		✓	920		Adjustable current limit, dynamic voltage scaling, enable, pre-bias start-up, voltage margining	✓	24 HTSSOP	2.20
TPS56C215	12	4.5 to 17	(0.6 to 5.5)	400, 800, 1200	D-CAP3		✓	✓	✓			800		EN, soft-start, pre-biased, ILIM	✓	3.5x3.5 mm HotRod	1.90
TPS53515	12	4.5 to 18	(0.6 to 5.5)	250 to 1000	D-CAP3		✓	✓	✓		✓	1350		EN, pre-biased and ILIM	✓	28 QFN (3.5x4.5 mm)	2.70
TPS53915	12	4.5 to 18	(0.6 to 5.5)	250 to 1000	D-CAP3		✓	✓	✓			1350		EN, PMBus prog.	✓	28 QFN (3.5x4.5 mm)	3.05
TPS51367	12	3.0 to 22	(0.6 to 2)	800	D-CAP2		✓	✓	✓		✓	100		Enable, Output Discharge	✓	28 QFN	2.7
TPS548A20	15	4.5 to 20	(0.6 to 5.5)	200 to 1000	D-CAP3		✓	✓	✓		✓	1350		EN, pre-biased, ILIM	✓	28 QFN (3.5x4.5 mm)	2.89
TPS549A20	15	4.5 to 20	(0.6 to 5.5)	200 to 1000	D-CAP3		✓	✓	✓		✓	1350		EN, pre-biased, ILIM, PMBus prog.	✓	28 QFN (3.5x4.5 mm)	3.18
TPS56121	15	4.5 to 14	(0.6 to 12)	300/500/1000	VM	✓	✓		✓		✓	2500		EN, pre-biased, ILIM	✓	22 QFN (5x6 mm)	3.50
TPS53353	20	4.5 to 15	(0.6 to 5.5)	250 to 1000	D-CAP TM		✓	✓	✓		✓	320		EN, pre-biased, ILIM	✓	22 QFN (5x6 mm)	3.50
TPS544B20	20	4.5 to 18	(0.6 to 5.5)	250 to 1000	D-CAP, D-CAP2		✓		✓			8000		EN, remote sense, ILIM, pre-biased, PMBus prog. with telemetry	✓	40 QFN (5x7 mm)	3.70
TPS544B25	20	4.5 to 18	(0.5 to 5.5)	200 to 1000	VM with FF	✓	✓		✓	✓		9500		EN, remote sense, ILIM, pre-biased, PMBus prog. with telemetry	✓	40 QFN (5x7 mm)	4.08
TPS56221	25	4.5 to 14	(0.6 to 12)	300/500/1000	VM	✓	✓		✓		✓	2500		EN, pre-biased, ILIM	✓	22 QFN (5x6 mm)	3.75
TPS53355	30	4.5 to 15	(0.6 to 5.5)	250 to 1000	D-CAP		✓	✓	✓		✓	320		EN, pre-biased, ILIM	✓	22 QFN (5x6 mm)	3.75
TPS544C20	30	4.5 to 18	(0.6 to 5.5)	250 to 1000	D-CAP, D-CAP2		✓		✓			8000		EN, remote sense, ILIM, pre-biased, PMBus prog. with telemetry	✓	40 QFN (5x7 mm)	3.90
TPS544C25	30	4.5 to 18	(0.5 to 5.5)	200 to 1000	VM with FF	✓	✓		✓	✓		7700		EN, remote sense, ILIM, pre-biased, PMBus prog. with telemetry	✓	40 QFN (5x7 mm)	4.49
TPS546C20A/23	35	4.5 to 18	(0.35 to 5.5)	200 to 1000	VM with FF	✓	✓		✓	✓		7700		Parallel 2X, EN, remote sense, ILIM, pre-biased, PMBus prog. with telemetry		40 QFN (5x7 mm)	4.92
TPS548D22	40	4.5 to 16	(0.6 to 5.5)	425, 650, 875, 1050	D-CAP3		✓	✓	✓			2000		EN, soft-start, remote sense, ILIM, pre-biased	✓	40 QFN (5x7 mm)	4.19

¹VM = voltage mode, CM = current mode, COT = constant on time, FF = feed forward, DCS = direct control with seamless transition into power-save mode.

New devices are listed in bold red.

*Suggested resale price in U.S. dollars in quantities of 1,000.

Device	I _{OUT} (A)	V _{IN} (V)	V _{OUT} (V) (Adj.)/Fixed	Switching Frequency (typ) (kHz)	Control Mode ¹	External Compensation	Synchronous Rectifier	Light-Load Efficiency	Power Good	Synch. to Ext. CLK Pin	Adjustable Soft Start	I _Q (typ) (μA)	Automotive Grade	Other Features	EVM	Package(s)	Price*
Wide Input Voltage (>30 V_{IN} Max)																	
LMR14203/06	0.3/0.6	4.5 to 42	(0.765 to 34)	1250	CM							1300		Enable		TSOT-23	0.90/0.99
LMR14006	0.6	4 to 40	(0.8 to 30)	1100, 2100	CM		✓					28		Enable, pre-bias start-up, UVLO adj.	✓	TSOT-6L	0.80
LMR14010A	1	4 to 40	0.8 to 30	700	CM		✓					30		Enable, pre-bias start-up		SOT23-6	1.00
LM34919/B/C	0.6	6/4.5 to 40/50	(2.5 to 35)	Up to 2600	COT			✓	✓			500	✓	Soft start	✓	10 micro SMD, 12 WSON, DSBGA	1.20/1.25
LMR23610/25/30	1/2.5/3	4 to 36	1 to 30	2200	CM	✓	✓	✓	✓			75	✓	Enable, pre-bias start-up, UVLO adj.	✓	8 SO PowerPAD TM	1.30/1.35/1.54
LMR23615/25/30	1.5/2.5/3	4 to 36	1 to 30	2200	CM	✓	✓	✓	✓			75	✓	Enable, pre-bias start-up, UVLO adj.	✓	WSON12 (3x3 mm)	1.30/1.35/1.54
LMR33620/30	2/3	3.8 to 38	(1 to 24)	400/1400/2100	CM	✓	✓	✓	✓			24	✓	Enable, pre-bias start-up	✓	8 SOIC (3x2 mm) QFN12	1.55/1.65
LM43600/01/02/03	0.5/1/2/3	3.5 to 36	1 to 28	200 to 2200	CM	✓	✓	✓	✓			33/33/27/27		Enable, tracking	✓	16 HTSSOP, WSON	1.50-1.85
LM53600/1-Q1	0.65/1	3.5 to 42	(3.3 to 9.9)/3.3/5	2100	CM	✓	✓	✓	✓			23	✓	Soft start, current limit, UVLO	✓	WSON	1.89/1.96
LM53602/3-Q1	2/3	3.5 to 42	(3.2 to 9.9)/3.3/5	2100	CM	✓	✓	✓	✓			38	✓	Soft start, current limit, UVLO	✓	HTSSOP	2.09/2.20
LM53625/35-Q1	2.5/3.5	3.5 to 42	(3.2 to 10)/3.3/5	2100	CM	✓	✓	✓	✓			15	✓	Enable, Soft start, UVLO, Spread Spectrum	✓	WQFN (5x4 mm)	2.14/2.30
LMS3635/55-Q1	3.5/5.5	3.5 to 42	(1-15)/3.3/5	400	CM	✓	✓	✓	✓			15	✓	Enable, Soft start, UVLO, Spread Spectrum	✓	WQFN (5x4 mm)	2.83/3.30

¹VM = voltage mode, CM = current mode, COT = constant on time, /ER = with emulated ripple

New devices are listed in bold red. Preview devices are listed in bold teal.

*Suggested resale price in U.S. dollars in quantities of 1,000.

Non-Isolated DC/DC Switching Regulators

Step-Down (Buck)

Buck Converters, Single Channel (Continued)

Device	I _{OUT} (A)	V _{IN} (V)	V _{OUT} (V) (Adj.)/Fixed	Switching Frequency (typ) (kHz)	Control Mode ¹	External Compensation	Synchronous Rectifier	Light-Load Efficiency	Power Good	Synch. to Ext. CLK Pin	Adjustable Soft Start	I _O (typ) (μA)	Automotive Grade	Other Features	EVM	Package(s)	Price*
Wide Input Voltage (>30 V_{IN} Max) (Continued)																	
LM73605/6	5/6	3.5 to 42	(1 to 34)	350 to 2200	CM	✓	✓	✓	✓	✓	✓	15	✓	Enable, Soft start, UVLO, Tracking		WQFN (6x4 mm)	2.55
LM25019/18/17	0.1/0.3/0.65	7.5 to 48	(1.25 to 40)	50 to 1000	COT		✓					1750		UVLO adj.,	✓	8 LLP, 8 PSOP	1.25/1.40/1.57
LM25011	2	6 to 42	(2.51 to 40)	Up to 2000	COT/ER				✓		✓	1200	✓	Ilim, adj. soft start	✓	10 MSOP	1.08
LMR14020/30/50	2/3.5/5	4 to 40	(1 to 36)	2500 max	CM			✓		✓	✓	40	✓	Enable, pre-bias start-up, tracking, UVLO adj.	✓	8 HSOIC	1.30/1.40/1.75
LMR14020-Q1	2	4 to 40	(1 to 36)	200 to 2500	CM			✓	✓	✓		40	✓	Enable, tracking, UVLO adj.	✓	HSOIC-8/ WSON(10)	1.53
LMR14030-Q1	3.5	4 to 40	(1 to 36)	200 to 2500	CM			✓	✓	✓		40	✓	Enable, tracking, UVLO adj.	✓	HSOIC-8/ WSON(10)	1.65
LMR14050-Q1	5	4 to 40	(1 to 36)	200 to 2500	CM			✓	✓	✓		40	✓	Enable, tracking, UVLO adj.	✓	HSOIC-8/ WSON(10)	2.07
TPS54040A/140A/240	0.5/1.5/2.5	3.5 to 42	(0.8 to 39)	100 to 2500	CM	✓		✓	✓	✓	✓	116	✓	Enable, tracking, automotive version is TPS57040/140	✓	10 MSOP, 10 SON (3x3 mm)	0.90/0.95/1.20
TPS54340/540	3.5/5	3.5 to 42	(0.8 to 39)	100 to 2500	CM	✓		✓	✓	✓	✓	138	✓	Enable, tracking	✓	8 HSOIC	1.50/1.75
TPS54341/541	3.5/5	4.5 to 42	(0.8 to 41)	100 to 2500		✓		✓	✓	✓	✓	152	✓	Enable, UVLO adj., boot pin charge FET, tracking	✓	10 WSON (4x4mm)	1.65/1.90
TPS5410/20/30/50	1/2/3/5	5.5 to 36	(1.23 to 31)	500	VM							3000	✓	Enable	✓	8 SOIC	1.32-2.00
LM2574/75/76	0.5/1/3	4 to 40	(3.3 to 37)	52/52/42 to 52/52/63	VM									Enable		14 SOIC/8 PDIP	1.04/0.78/1.19
LM2594/95/96	0.5/1/3	4.5 to 40	(3.3 to 37)	110 to 173	VM							5000		Enable		8 SOIC/8 PDIP	1.20/1.60/1.80
LM22674/75/76/77	0.5/1/3/5	4.5 to 42	(1.2 to 37)	500								3400		Enable		8 SO PowerPAD™	1.25/1.55/2.50
LM2674/75/76/77	0.5/1/3/5	6.5 to 40	(1.2 to 37)	260	VM							2500/2500/4200/4200		Enable		16 WSON/8 SOIC/8 PDIP	1.20/1.60/2.25
TPS54062	0.05	4.7 to 60	(0.8 to 58)	100 to 400	CM	✓	✓				✓	89		Enable, UVLO adj.	✓	8 MSOP	0.75
TPS54061	0.2	4.7 to 60	(0.8 to 58)	50 to 1100	CM	✓	✓	✓	✓	✓	✓	90	✓	Enable, UVLO adj.	✓	8 SON (3x3 mm)	0.90
LM5165	0.15	3 to 65	(1.23 to 65)	50 to 600	COT		✓	✓	✓	✓	✓	10	✓	Ilim, Enable, UVLO	✓	10 VSON	1.35
LM5166	0.5	3 to 65	(1.23 to 65)	50 to 600	COT		✓	✓	✓	✓	✓	10		Ilim, Enable, UVLO	✓	10 VSON	1.45
LM5019/18/17	0.1/0.3/0.65	7.5 to 100	(1.25 to 90)	50 to 1000	COT		✓					1750		UVLO adj.,	✓	8 LLP, 8 PSOP	1.25/1.40/1.57
LM5009/A	0.15	9.5/6 to 95	(2.5 to 85)	50 to 600	COT							485		Current limit	✓	8 LLP, 8 MSOP	1.10
LM5008/A	0.35	8/6 to 95	(2.5 to 75)	50 to 600	COT							485		Soft start	✓	8 LLP, 8 MSOP	1.18/1.20
LM5007	0.5	9 to 75	(2.5 to 73)	50 to 800	COT							500			✓	8 LLP, 8 MSOP	1.30
LM5006	0.65	6 to 75	(2.5 to 75)	50 to 800	COT							1000		UVLO adj.	✓	10 MSOP	1.40
LM5010/A	1	8/6 to 75	(2.5 to 70)	50 to 1000	COT						✓	650	✓	Soft start	✓	10 LLP, 14 eTSSOP	1.47
LM5005	2.5	7 to 75	(1.23 to 70)	50 to 500	CM	✓				✓	✓	3000		Enable	✓	20 eTSSOP	1.75
LM5574/5/6	0.5/1.5/3	6 to 75	(1.2 to 70)	50 to 500	CM							1000		Enable, tracking	✓	16 TSSOP	1.55
LMR36006/15	0.6/1.5	4.2 to 60	(1 to 57)	400/1000/2100	CM		✓	✓	✓			25	✓	Enable, pre-bias start-up	✓	12 QFN (3x2 mm)	1.65
LM46000/01/02	0.5/1/2	3.5 to 60	(1 to 28)	200 to 2200	CM		✓	✓	✓	✓		24		Enable, tracking, UVLO adj.	✓	16 HTSSOP	1.65
LM76002/3	2.5/3.5	3.5 to 65	(1 to 57)	300 to 2200	CM		✓	✓	✓	✓	✓	15	✓	Enable, Soft start, UVLO, Tracking	✓	WQFN (6x4 mm)	2.50/2.55
LM5160/A	2	4.5 to 65	(2 to 60)	50 to 1000	COT		✓				✓	2300		Enable, pre-bias start-up, UNLO adj.	✓	12 WSON	1.80
LM5161	1	6-100	(2 to 92)	50 to 1000	COT		✓		✓			2300	✓	Enable, UVLO adj., prebias-start up, adj. soft-start	✓	16 HTSSOP	1.80
LMR16006	0.6	4 to 60	(0.8 to 55)	2100	CM			✓				28		Enable, pre-bias start-up, UVLO adj.	✓	6 SOT	1.20
LMR16010/20/30	1/2/3	4.5 to 60	(1 to 50)	200 to 2500	CM			✓	✓	✓		40		Enable, pre-bias start-up, tracking, UVLO adj.	✓	8 SO PowerPAD	1.50/1.82/1.95
TPS54060A/160A/260	0.5/1.5/2.5	3.5 to 60	(0.8 to 58)	100 to 2500	CM	✓		✓	✓	✓	✓	116	✓	Enable, tracking, automotive version is TPS57140/60	✓	10 MSOP, 10 SON (3x3 mm)	1.10/1.35/1.50
TPS54360/560	3.5/5.0	4.5 to 60	(0.8 to 58)	100 to 2500	CM	✓		✓		✓		146	✓	Enable, UVLO adj., boot pin charge FET	✓	8 HSOIC	1.80/2.10
TPS54361/561	3.5/5.0	4.5 to 60	(0.8 to 59)	100 to 2500		✓		✓	✓	✓	✓	152	✓	Enable, UVLO adj., boot pin charge FET, tracking	✓	10 WSON (4x4 mm)	2.00/2.30
LM2574HV/75HV/76HV	0.5/1/3	4 to 60	(3.3 to 37)	52	VM							5000		Enable		8 DIP/14 SOIC/T0220	1.45-2.30
LM2591HV/92HV	1/2	4.5 to 60	(3.3 to 57)	110 to 173	VM							1000/10000				5 DPAK/T0-263/5 TO-220	2.00/2.40

¹VM = voltage mode, CM = current mode, COT = constant on time, /ER = with emulated ripple
 *Suggested resale price in U.S. dollars in quantities of 1,000.

New devices are listed in bold red. Preview devices are listed in bold teal.

Non-Isolated DC/DC Switching Regulators

Step-Down (Buck)

Buck Converters, Multi-Channel

Device	I _{OUT} (A)	V _{IN} (V)	V _{OUT} (V) (Adj.)/Fixed	Switching Frequency (kHz)	Control Mode ¹	Ext. Compensation	Synchronous Rectifier	Light-Load Efficiency	Power Good Pin	Sync Pin	Adj. Soft Start	I _Q (typ) (μA)	Automotive Grade	Other	EVM	Package(s)	Price*
Dual Channel																	
TPS62770	0.3/0.1	2.5 to 5.5	Select. (1.0 to 3.0)	1200	DCS		✓	✓				0.37		Ultra-low-I _Q buck and boost	✓	WCSP	0.70
TPS62400	0.4/0.6	2.5 to 6.0	(0.6 to V _{IN})/(1.1 to 1.9/3.3)	2250	VM		✓	✓				32	✓	EasyScale™ interface	✓	QFN	0.67
TPS62420	0.6/1	2.6 to 6.0	(0.6 to V _{IN})	2250	VM		✓	✓				32	✓	EasyScale interface	✓	QFN	0.73
TPS62410	0.8/0.8	2.6 to 6.0	(0.6 to V _{IN})	2250	VM		✓	✓				32	✓	EasyScale interface		QFN	0.73
TPS54290/1/2	1.5/2.5	4.5 to 18	(0.8 to 16.2/15.3/14)	300/600/1200	CM		✓					1800		Enable, phase interleaving, sync. rect.	✓	16 HTSSOP	2.40
TPS54294/5	2/2	4.5 to 18	(0.76 to 7)	700	D-CAP2™		✓		✓/-	-/✓		1300		Enable, sync. rect.	✓	16 HTSSOP, 16 QFN	1.00
TPS54283/6	2/2	4.5 to 28	(0.8 to 25.2)	300/600	CM							1800		Enable, phase interleaving		14 HTSSOP	1.70
LM26420	2/2	3.0 to 5.5	(0.8 to 4.5)	550/2200	CM							900	✓		✓	QFN, HTSSOP	1.50
LM2717-ADJ	2.2/3.2	4 to 20	(1.627 to 3.3)	300, 600							✓				✓	24 TSSOP	2.65
LM2717	2.2/3.2	4 to 20	3.3	300, 600							✓				✓	24 TSSOP	2.65
TPS55383/6	3/3	4.5 to 28	(0.8 to 25.2)	300/600	CM	✓						1800			✓	16 HTSSOP	2.65
TPS65283/65283-1	3.5/2.5	4.5 to 18	0.6 min	200 to 2000	CM	✓	✓	-/✓	✓			500		Adj. current limit, enable, UVLO adj.	✓	24 VQFN	1.50
TPS54494/5	4/2	4.5 to 18	0.76 to 7	700	D-CAP2		✓		✓/-	-/✓		1200		Enable, pre-biased soft start, OCL, UVLO, TSD	✓	16 HTSSOP, 16 QFN	1.30
TPS65279	5/5	4.5 to 18	0.6 to 15	200 to 1600	CM	✓	✓	✓	✓	✓	✓	10000		Enable, light load efficiency, phase interleaving	✓	32 HTSSOP, 36 QFN	1.90
TPS65279V	5/5	4.5 to 18	0.6 to 15	200 to 1600	CM	✓	✓	✓	✓	✓	✓	10000		Enable, light load efficiency, multiple outputs, phase interleaving	✓	32 HTSSOP, 36 QFN	1.90
Triple Channel																	
TPS65580/1	2.5/1.5/1.5	4.5 to 18	0.76 min	700	CM		✓	✓/-	✓			600		Enable, over current protection, thermal shutdown, UVLO fixed	✓	20 TSSOP	1.50
TPS65262/-1	3/1/1	4.5 to 18	0.6 min	600	CM	✓	✓	✓	✓		✓	790		Adjustable current limit, enable, phase interleaving, UVLO adj.	✓	32 VQFN	1.50
TPS65261/-1	3/2/2	4.5 to 18	0.6 min	250 to 2000	CM	✓	✓	✓	✓	✓	✓	600		Enable, light load efficiency, UVLO adj.	✓	32 VQFN	1.40
TPS65266/66-1	3/2/2	2.7 to 6.5	0.6 to 5.5	250 to 2400	CM		✓	-/✓	✓	✓	✓	340		Enable, phase interleaving, UVLO adj.	✓	32 QFN	1.60/1.80
TPS65263	3/2/2	4.5 to 18	0.6 min	600	CM	✓	✓	✓	✓		✓	740/600	✓	Adj. current limit, dynamic voltage scaling, enable, UVLO adj.	✓	32 VQFN	1.50
TPS65263Q1	3/2/2	4.5 to 18	0.6 min	200 to 2300	CM	✓	✓	✓	✓	✓	✓	1000	✓	Adj. current limit, dynamic voltage scaling, enable, UVLO adj.	✓	32 VQFN	2.12
TPS65266/66-1	3/2/2	2.7 to 6.5	0.6 to 5.5	250 to 2400	CM		✓	-/✓	✓	✓	✓	340		Enable, phase interleaving, UVLO adj.	✓	32 QFN	1.60/1.80
TPS65263-1Q1	3/2/2	4 to 18	0.6 to 16	200 to 2300	CM		✓	✓	✓	✓	✓	370	✓	Dynamic voltage scaling, enable, phase interleaving, UVLO adj.	✓	32 QFN	3.54
TPS65265	5/3/2	4.5 to 17	0.6 min	250 to 2300	CM	✓	✓	✓	✓	✓	✓	11.5			✓	32 VQFN	1.25
TPS652510	3/2/2	4.5 to 16	0.8 min	300 to 2200	CM	✓	✓	✓	✓	✓	✓	20000	✓	Adj. current limit, enable, phase interleaving, pre-bias start-up, UVLO adj.	✓	40 VQFN	1.60
TPS65251	3/2/2	4.5 to 18	0.8 to 17	300 to 2200	CM	✓	✓	✓	✓	✓	✓	20000	✓	Adj. current limit, enable, phase interleaving, UVLO adj.	✓	40 VQFN	1.60
TPS65250	3/2/2	4.5 to 18	0.8 to 17	300 to 2200	CM	✓	✓	✓	✓	✓	✓	1000		Adj. current limit, enable, UVLO adj.	✓	40 VQFN	1.60
TPS65251-1/-2/-3	3/2/2	4.5 to 18	0.8 to 17	300 to 2200	CM	✓	✓	✓	✓	✓	✓	600		Adj. current limit, enable, phase interleaving, UVLO adj.	✓	40 VQFN	1.60
TPS65257	3/2/2	4.5 to 18	0.8 to 15	300 to 2200	CM	✓	✓	✓	✓	✓	✓	700		Adj. current limit, enable, pre-bias start-up, UVLO adj.	✓	40 VQFN	2.30
TPS65287	3/2/2	4.5 to 18	0.8 to 17	300 to 2200	CM	✓	✓	✓	✓	✓	✓	700		Adj. current limit, enable, pre-bias start-up, UVLO adj.	✓	40 VQFN	2.30
TPS65288	3/2/2	4.5 to 18	0.8 to 17	300 to 2200	CM	✓	✓	✓	✓	✓	✓	700		Adj. current limit, enable, pre-bias start-up, UVLO adj.	✓	40 VQFN	2.30
Quad Channel																	
TPS65400	4/4/2/2	4.5 to 18	0.6 to 16	275 to 2200	CM	✓	✓	✓	✓	✓	✓	6300	✓	Adj. current limit, dynamic voltage scaling, enable, PMBus, phase interleaving, pre-bias start-up, UVLO adj.	✓	48 VQFN	2.10

¹VM = voltage mode, CM = current mode

*Suggested resale price in U.S. dollars in quantities of 1,000.

Non-Isolated DC/DC Switching Regulators

Step-Down (Buck)

Buck Controllers (External Switch)

All parts have soft start, short-circuit protection, and undervoltage lockout functions.

Device	Mode of Control ¹	V _{IN} (min/max) (V)	V _O (min/max) (V)	Driver Current (A)	Output Current (A) ²	Frequency (kHz)	V _{REF} Tol (%)	Internal Bootstrap	Package(s)	Pwr Good	Source and Sink ³	Pre-biased Operation	Ext Synchron Pin	Predictive Gate Drive™	DDR ⁴	Remote Sense	Automotive Grade	Price*
General-Purpose DC/DC Step-Down Controllers																		
TPS40000	VM	2.25 to 5.5	0.7 to 4	1	15	300/600	1	Yes	10 MSOP			Yes		Yes				1.20
TPS40007/9	VM	2.25 to 5.5	0.7 to 4	1	15	300/600	1	Yes	10 MSOP		Yes ⁵	Yes		Yes				0.99
TPS40040	VM	2.25 to 5.5	0.6 to 4.95	1	15	300	1	Yes	8 SON		Yes ⁵	Yes						0.85
TPS40041	VM	2.25 to 5.5	0.6 to 4.88	1	15	600	1	Yes	8 SON		Yes ⁵	Yes						0.85
TPS40042	VM	3 to 5.5	0.7 to 4.95	1.2	15	600	Ext	Yes	10 SON		Yes ⁵	Yes			Yes			0.90
TPS40190	VM	4.5 to 15	0.59 to 12.75	1.2	20	300	1	Yes	10 SON		Yes ⁵	Yes						0.90
LM2742	VM	1 to 16	0.6 to 13.5	1.6	20	50 to 2000	1.5		14 TSSOP	Yes								0.80
LM2743	VM	1 to 16	0.6 to 13.5	1.6	20	50 to 2000	2		14 TSSOP	Yes								0.80
TPS40100 ⁶	CM	4.5 to 18	0.7 to 5.5	1.3	20	600	1		24 QFN	Yes	Yes ⁵	Yes	Yes			Yes		1.60
TPS40101 ⁶	VM	4.5 to 18	0.7 to 5.5	1.3	20	1000	1		24 QFN	Yes	Yes ⁵	Yes	Yes			Yes		1.65
LM3754	VM	4.5 to 18	0.6 to 3.6	1.9	50	200 to 1000	1		32 LLP	Yes		Yes	Yes			Yes		2.95
TPS40192/3	VM	4.5 to 18	0.59 to 14.4	1.2	15/20	600/300	0.5	Yes	10 SON	Yes	Yes ⁵	Yes						0.85
LM3153	COT	8 to 18	3.3	0.2	12	750	1.5		14 HTSSOP		Yes	Yes						1.35
TPS40195 ⁷	VM	4.5 to 20	0.59 to 17	1.2	20	Adj. to 600	0.5	Yes	16 TSSOP, 16 QFN	Yes	Yes ⁵	Yes	Yes ⁸					0.99
TPS40400	VFF, PMBus™	3 to 20	0.6 to 12	2	25	Adj. to 2000	1	Yes	24 QFN	Yes	Yes	Yes	Yes			Yes		2.00
TPS40303/4/5	VM	3 to 20	0.6 to 18	2	25	300/600/1200	1	Yes	10 SON	Yes	Yes ⁵	Yes						0.85
LM27402	VM	3 to 20	0.6 to 19	2.6	30	200 to 1200	1		LLP-16, 16 TSSOP	Yes		Yes	Yes					1.10
LM27403	VM	3 to 20	0.6 to 19	2.6	30	200 to 1200	1		24 WQFN	Yes		Yes	Yes					0.95
TPS53125/6/7 (dual output)	D-CAP2™	4.5 to 26	0.76 to 5.5	1.5	15	350/700	1	Yes	24 QFN, 24 TSSOP		Yes	Yes						1.60
TPS53014/15	D-CAP2	4.5 to 28	0.76 to 7	1.5	25	500	1	Yes	10 MSOP	No/ Yes	Yes	Yes						0.90
TPS40075	VFF	4.5 to 28	0.7 to 23	1	20	Adj. to 1000	1	Yes	20 QFN	Yes	Yes ⁵	Yes	Yes	Yes		Yes		1.35
TPS40077	VFF	4.5 to 28	0.7 to 23	1	20	Adj. to 1000	1	Yes	16 PowerPAD™	Yes	Yes ⁵	Yes		Yes				1.35
TPS53819A	D-CAP2, PMBus	3 to 28	0.6 to 5.5	2	40	270 to 1000	0.5	Yes	16 QFN	Yes	Yes	Yes						0.99
LM3152	COT	6 to 33	3.3	0.2	12	500	1.5		14 HTSSOP		Yes	Yes						1.35
LM3485	Hysteretic	4.5 to 35	1.242 to V _{IN}	0.4	4	0 to 1400/1000	2		8 MSOP								✓	0.52
LM3489	Hysteretic	4.5 to 35	1.239 to V _{IN}	0.4	4	0 to 1400	2		8 MSOP								✓	0.54
LM3477	CM	2.97 to 35	1.265 to 30.8	1.0	6	500	1.5		8 MSOP									0.85
TPS40200 ⁸	VFF	4.5 to 52	0.7 to 46	0.2	3	Adj. to 500	1	Note 9	8 SOIC				Yes				✓	0.74
TPS40170	VFF	4.5 to 60	0.6 to 58	1.2	15	Adj. to 600	1	Yes	20 QFN	Yes	Yes ⁵	Yes	Yes				✓	1.50
LM(2)5141	CM	3.8 to 42/65	1.5/15	4	25	350 to 2600	1	Yes	40 QFN	Yes	Yes	Yes	Yes				✓	1.75
LM(2)5145	VM	6/(42)75	0.8/(40)60	3.5	25	100 to 1000	1.5	Yes	20 VQFN	Yes	Yes	Yes	Yes					2.30
LM(2)5117	ECM	5.5 to 42/65	0.8 to 41/62	2.2	20	50 to 750	1.5		20 TSSOP, 24 LLP				Yes				✓	1.70/2.10
LM(2)5085/A	COT	4.5 to 42/75	1.25/0.9 to V _{IN}	1.5	10	1000	2		8 MSOP, 8 LLP								✓	0.70/0.75/ 0.85
LM(2)5088	ECM	4.5 to 42/75	1.2 to 40/70	1.5	10	50 to 1000	1.5		e16 TSSOP				Yes				✓	1.25/1.47
LM(2)5115/A	V	4.5 to 42/75	0.75 to 13.5	2.5	20	100 to 1000	1.7		16 TSSOP				Yes					1.05/1.80
LM(2)5116	ECM	6 to 100	1.2 to 80	3.5	20	50 to 1000	1.5		20 eTSSOP				Yes					1.70/2.42
TPS40345	VM	3 to 20	0.6 to 18	2	25	600	1	Yes	10 SON	Yes	Yes ⁵	Yes						0.75

¹VM = Voltage-mode control, CM = Current-mode control, VFF = Voltage mode with voltage feed-forward compensation, ECM = Emulated current mode and COT = Constant ON-time control.

²Current levels of this magnitude can be supported with commonly available commercial FETs.

³The controller of choice for most applications will be the source/sink version, which has two-quadrant operation and will source or sink output current.

⁴DDR = Supports DDR memory.

⁵During soft start: source only.

⁶Provides advanced start-up sequencing and output voltage margining.

⁷Bidirectional 180° out-of-phase synchronization.

⁸Non-synchronous, drives P-FETs.

⁹Drives high-side P-FET.

*Suggested resale price in U.S. dollars in quantities of 1,000.

Non-Isolated DC/DC Switching Regulators

Step-Down (Buck)

Buck Controllers (Continued)

All parts have soft start, short-circuit protection, and undervoltage lockout functions.

Device	Mode Control ¹	Switched Outputs	Phases	V _{IN} (min/max) (V)	V _O (min/max) (V)	Driver Current (A)	Output Current (A) ²	Frequency (kHz)	V _{REF} Tol (%)	Package(s)	Pwr Good	Overshoot Protection	Source and Sink ³	Pre-biased Operation	Ext Synchron Pin	Remote Sense	Automotive Grade	Price*
Multiphase Synchronous DC/DC Buck Controllers																		
LM2642	CM	1 or 2	1 or 2	4.5/30	1.3/96% x V _{IN}	1.1	25/phase	300	1.8	28L TSSOP	Yes	Yes						1.48
LM2647	VFF	1 or 2	1 or 2	5.5/28	0.6/6.0	2	25/phase	Adj. 200 to 500	1.5	28L TSSOP	Yes	Yes						1.80
LM3000	ECM	1 or 2	1 or 2	3.3/18.5	0.6/80% x V _{IN}	—	25/phase	Adj. 200 to 1500	1.5	32L LLP	Yes	Yes	Yes					2.75
LM3754	VFF	1 or 2	1 or 2	4.5/18	0.6/3.6	4	25/phase	Adj. 200 to 1000	1	32L LLP	Yes	Yes	Yes	Yes	Yes			2.95
LM(2)5119	ECM	1	2	4.5/5.5 to 42/65	0.8 to 41.3/64	2.2	50	50 to 750	1.5	32 LLP					Yes	✓	2.60/3.25	
LM5642	CM	1 or 2	1 or 2	4.5/36	1.3/90% x V _{IN}	1.1	25/phase	200	1.7	28L TSSOP	Yes	Yes			Yes			1.75
LM5642x	CM	1 or 2	1 or 2	4.5/36	1.3/90% x V _{IN}	1.1	25/phase	375	1.7	28L TSSOP	Yes	Yes			Yes			1.75
TPS40132	CM	1	2	1/40	0.6/5.8	1	50	Adj. to 1000	0.8	32 QFN	Yes	Yes	Yes	Yes	Yes	Yes		2.95
TPS40140 ⁴	CM	1 or 2	1 or 2	2/40	0.7/5.8	1.2	25/phase	Adj. to 1000	0.5	36 QFN	Yes	Yes	Yes	Yes	Yes	Yes		3.05
TPS40180 ⁵	CM	1	1	2/40	0.7/5.8	1.2	25	Adj. to 1000	0.75	24 QFN	Yes	Yes	Yes	Yes	Yes	Yes		2.05
TPS40322	VFF	1 or 2	1 or 2	3/20	0.6/5.6	2	25/phase	Adj. to 1000	1	32 QFN	Yes	Yes	Yes	Yes	Yes	Yes		2.40
TPS40422	VFF/PMBus	1 or 2	1 or 2	4.5/20	0.6/5.6	2	25/phase	Adj. to 1000	1	40 QFN	Yes	Yes	Yes	Yes	Yes	Yes		3.10
TPS40425/8 ⁶	VFF/PMBus	1 or 2	1 or 2	4.5/20	0.6/5.0	2	25/phase	Adj. 200 to 1500	0.5	40 QFN	Yes	Yes	Yes	Yes	Yes	Yes		4.80
LM5140	CM	2	2	3.8/65	1.5/15	4	25/phase	Adj. 350 to 2600	1	40 QFN	Yes	Yes	Yes		Yes	✓	3.90	
TPS53647	DCAP+™/PMBUS	1	1, 2, 3, or 4	4.5/17	0.5/2.5	—	160	Adj. 300 to 1000	1	40 QFN	Yes	Yes	Yes	Yes	No	Yes		3.85
TPS53667	DCAP+™/PMBUS	1	1, 2, 3, 4, 5, or 6	4.5/17	0.5/2.5	—	240	Adj. 300 to 1000	1	40 QFN	Yes	Yes	Yes	Yes	No	Yes		4.25
TPS53681	DCAP+™/PMBUS	2	6+2/5+3	4.5/17	0.25/2.8125	—	320	Adj. 300 to 1000	1	40 QFN	Yes	Yes	Yes	Yes	No	Yes		4.65

Device	Switched Outputs	LDO Outputs	Phases	V _{IN} (min/max) (V)	V _O (min/max) (V)	Driver Current (A)	Output Current (A) ²	Frequency (kHz)	V _{REF} Tol (%)	Control Method	Internal Bootstrap	Package(s)	Overshoot Protection	Power Good	ULQ™ ⁷	Price*
DC/DC Synchronous Buck Controllers with Light-Load Efficiency																
TPS53128/29	2	0	1	4.5/24	0.76/24	1.5	15	350/700	1	D-CAP™ Mode	Yes	24 QFN, 28 TSSOP	Yes			1.70
TPS51220A	2	2	1	4.5/32	1.0/12.0	2	20	200 to 1000	1	Current or D-CAP™ Mode	Yes	32 QFN	Yes	Yes		2.25
TPS51225/B/C	2	2	1	5.5/24	3.3/5.0 ⁸	1.7	10	300 to 335	1	D-CAP Mode	Yes	20 QFN	Yes	Yes		1.05
TPS51275/B/C	2	2	1	5.0/24	3.3/5.0 ⁸	1.7	20	330 to 335	1	D-CAP Mode	Yes	20 QFN	Yes	Yes		1.05
TPS51285A/B	2	2	1	5.0/24	3.3/5.0 ⁸	1.7	20	400 to 475	1	D-CAP Mode	Yes	20 QFN	Yes	Yes	Yes	1.05
TPS53211	1	0	1	4.5/15	0.8/0.7 x V _{IN}	2	25	200 to 600	0.5	Voltage	Yes	16 QFN	Yes	Yes		2.00
TPS53119	1	0	1	4.5/26	0.6/5.5	2	25	250 to 970	0.5	D-CAP Mode	Yes	16 QFN	Yes	Yes		0.75
TPS53219A	1	0	1	4.5/28	0.6/5.5	2	25	Select up to 1000	0.5	D-CAP Mode	Yes	16 QFN	Yes	Yes		0.85
TPS59124	2	0	1	3/28	0.76/5.5	3	10	300, 360, 420	1	D-CAP Mode	Yes	24 QFN	Yes	Yes		1.90

¹CM = Current-mode control, ECM = Emulated current mode and VFF = voltage mode with voltage feed-forward compensation.

²Current levels of this magnitude can be supported with commonly available commercial FETs.

³The controller of choice for most applications will be the source/sink version, which has two-quadrant operation and will source or sink output current.

⁴Stackable to 16 phases.

⁵Stackable to 8 phases, reference is trimmable.

⁶Stackable to 4 phases.

⁷ULQ = Ultralow quiescent-current mode.

⁸Fixed range: OUT1 = 5.0 V ±10% and OUT2 = 3.3 V ±10%.

*Suggested resale price in U.S. dollars in quantities of 1,000.

Processor V-Core Buck Controllers

Device	Mode of Control	Conversion Voltage Range (V)	Regulated Outputs	Phases	Max. Output Current (A)	Selectable Frequency	VID	CPU	Platform	Package	Price*
TPS59610	D-CAP+™	3 to 28	1	1	30	200 kHz to 500 kHz	IMVP6+	Tunnel Creek	Embedded	5x5-mm 32 QFN	1.40
TPS59620	D-CAP+	3 to 28	1	2	60	200 kHz to 500 kHz	IMVP6+	Penryn	Embedded	6x6-mm 40 QFN	2.20
TPS51611	D-CAP+	3 to 28	1	1	30	250 kHz to 500 kHz	IMVP6.5	Arrandale	Client	5x5-mm 32 QFN	1.25
TPS59621	D-CAP+	3 to 28	1	2	60	200 kHz to 500 kHz	IMVP6.5	Arrandale	Client	6x6-mm 40 QFN	1.80
TPS59640	D-CAP+	3 to 28	2	3+1	90	200 kHz to 600 kHz	IMVP7	Sandy Bridge	Client/Server	6x6-mm 48 QFN	2.25
TPS59650	D-CAP+	3 to 28	2	3+2	90	200 kHz to 600 kHz	IMVP7	Ivy Bridge	Client/Server	6x6-mm 48 QFN	2.65
TPS59641	D-CAP+	3 to 28	2	3+1	90	200 kHz to 600 kHz	VR 12.1	Baytrail-M/D/I	Client	6x6-mm 48 QFN	2.25
TPS51631/A	D-CAP+	3 to 28	1	3	90	300 kHz to 1 MHz	VR 12.5	Haswell/Broadwell/Broadwell-DE	Client/Tablet	4x4-mm 32 QFN	1.65

*Suggested resale price in U.S. dollars in quantities of 1,000.

Non-Isolated DC/DC Switching Regulators

Step-Down (Buck)

Processor V-Core Buck Controllers (Continued)

Device	Mode of Control	Conversion Voltage Range (V)	Regulated Outputs	Phases	Max. Output Current (A)	Selectable Frequency	VID	CPU	Platform	Package	Price*
TPS51622A	D-CAP+	4.5 to 28	1	2	40	300 kHz to 1 MHz	VR 12.6	Haswell/Broadwell-U/Y	Client/Tablet	4x4-mm 32 QFN	1.60
TPS51624	D-CAP+	4.5 to 28	1	2	40	300 kHz to 1.5 MHz	VR 12.6	—	Client/Tablet	4x4-mm 32 QFN	1.65
TPS51678	D-CAP+, I ² C	4.5 to 28	1	2	40	300 kHz to 1.5 MHz	VR 12.6	Broadwell-Y	Client/Tablet	4x4-mm 32 QFN	1.85
TPS51633	D-CAP+	4.5 to 28	1	3	90	300 kHz to 1 MHz	VR 12.6	Broadwell-H	Client	4x4-mm 32 QFN	1.85
TPS51623	D-CAP+	4.5 to 28	1	2	60	300 kHz to 1 MHz	VR 12.1	Braswell-M/D/I	Client	4x4-mm 32 QFN	1.20
TPS53622	D-CAP+, PMBus™	4.5 to 17	2	2	70	300 kHz to 860 MHz	VR13	Skylake, Broadwell-DE, Denverton	Server, Microserver	5x5-mm 40 QFN	2.95
TPS53625	D-CAP+	4.5 to 28	1	2	60	300 kHz to 1 MHz	VR12.0	Denverton, Avoton, Rangeley	Microserver	4x4-mm 32 QFN	2.00
TPS53626	D-CAP+	4.5 to 28	1	2	60	300 kHz to 1 MHz	VR13	Skylake, Broadwell-DE, Denverton	Server, Microserver	4x4-mm 32 QFN	2.15
TPS53640	D-CAP+, PMBus	4.5 to 17	1	3	120	300 kHz to 1 MHz	VR 12.5	Broadwell – EN/EP	Server	5x5-mm 40 QFN	2.80
TPS53640A	D-CAP+, PMBus	4.5 to 17	1	4	160	300 kHz to 1 MHz	VR 12.5	Broadwell – EN/EP	Server	5x5-mm 40 QFN	3.10
TPS53631	D-CAP+, PMBus	4.5 to 17	1	3	120	300 kHz to 1 MHz	VR 12.5	Broadwell – EN/EP	Server	5x5-mm 40 QFN	2.80
TPS53641	D-CAP+, PMBus	4.5 to 17	1	4	160	300 kHz to 1 MHz	VR 12.5	Broadwell – EN/EP	Server	5x5-mm 40 QFN	3.30
TPS53661	D-CAP+, PMBus	4.5 to 17	1	6	240	300 kHz to 1 MHz	VR 12.5	Broadwell – EN/EP	Server	5x5-mm 40 QFN	3.80
TPS53659	D-CAP+, PMBus	4.5 to 17	2	7	280	300 kHz to 1 MHz	VR13	Skylake-EN/EP, Skylake-D, Denverton	Server	5x5-mm 40 QFN	4.35
TPS53679	D-CAP+, PMBus	4.5 to 17	2	5	200	300 kHz to 1 MHz	VR13	Skylake-EN/EP	Server	5x5-mm 40 QFN	5.00

*Suggested resale price in U.S. dollars in quantities of 1,000.

Inductorless DC/DC Regulators (Charge Pumps) Family of Products

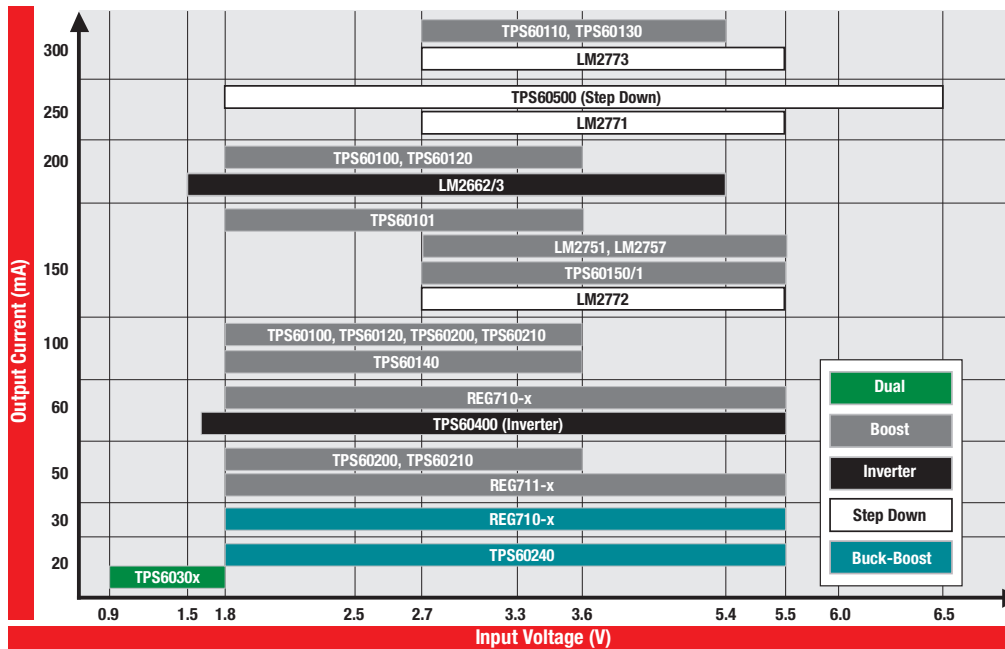

Buck Charge Pumps (Inductorless)

Device	I _{OUT} (mA)	V _{IN} (V)	V _{OUT} Adj. (V)	V _{OUT} Fixed (V)	Efficiency (%)	Switching Frequency (max) (kHz)	Quiescent Current (typ) (µA)	Shutdown Current (typ) (µA)	Features						Package(s)	EVM	Automotive Grade	Price*
									Shutdown	Low Battery	Power Good	Undervoltage Lockout	Current Limit	Thermal Limit				
LM2772	150	2.7 to 5.5	—	1.2	—	1100	45	—	✓						QFN-10	✓	0.33	
TPS60500	250	1.8 to 6.5	0.8 to 3.3	1.5, 1.8, 3.3	90	1200	40	0.05	✓		✓	✓	✓	✓	MSOP-10	✓	0.49	
LM2771	250	2.7 to 5.5	—	1.5	—	1100	45	—	✓						QFN-10		0.36	
LM2773	300	2.5 to 5.5	1.6 to 1.8	—	—	1150	48	—	✓						micro SMD-9	✓	0.36	

¹Device parameter, feature and/or price may vary with each device number in family.

*Suggested resale price in U.S. dollars in quantities of 1,000.

Non-Isolated DC/DC Switching Regulators

Step-Up (Boost)

DC/DC Step-Up Converters (Integrated Switch) Family of Products

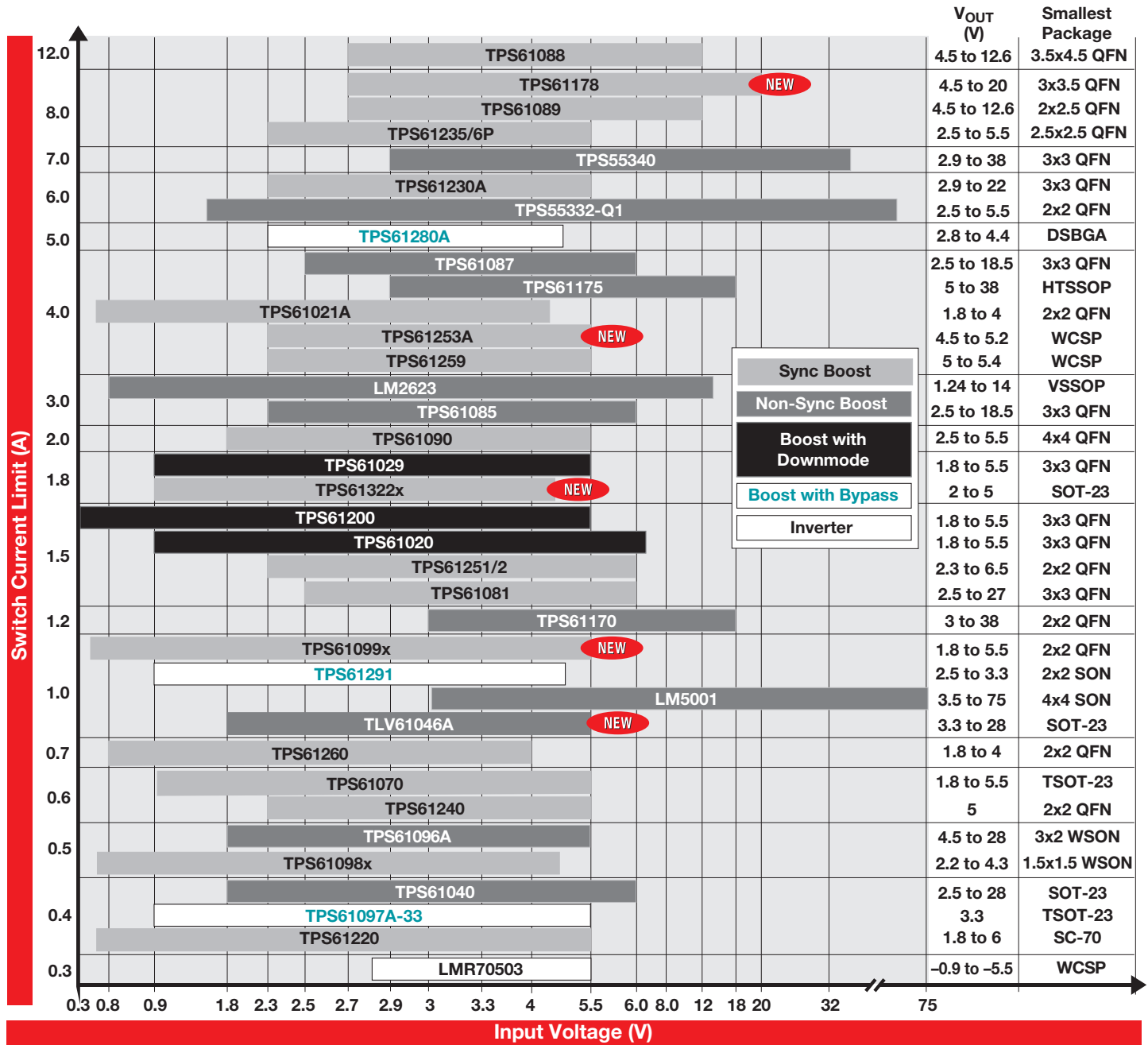

Non-Isolated DC/DC Switching Regulators

Step-Up (Boost)

Step-Up Regulators (Up to 10-A Switch Limit)

Device	Output/Switch Current ¹ (A)	Input Voltage (V)	Output Voltage (V)	Features	Automotive Grade	Package(s)	Price*
Boost							
TPS61220	0.4	0.7 to 5.5	1.8 to 6.0	Startup into load at 0.7-V input voltage, 5- μ A quiescent current		SC70 2x2	0.38
TPS61097A-33	0.4	0.9 to 5.5	3.3	0.9-Vin, 3.3-Vout Boost Converter with Bypass Switch, 5-nA Shutdown Current		SOT-23 3x3	0.70
TPS61040	0.4	1.8 to 6.0	1.8 to 28	28-V, 400-mA Switch Boost Converter in SOT-23 for LCD and White LED Applications	✓	SOT-23 3x3	0.50
TPS61098x	0.5	0.7 to 4.5	2.2 to 4.4	300-nA Iq, Boost + LDO/Load Switch (dual output)		SON 1.5x1.5	0.52
TPS61096A	0.5	1.8 to 5.5	4.5 to 28	28-V Output Voltage Boost Converter with 1- μ A Quiescent Current, Adjustable Current Limit		WSON 3x2	0.80
TPS61240	0.6	2.3 to 5.5	5.0 to 5.0	3.5-MHz High Efficiency Step-Up Converter	✓	WSON, DSBGA	0.40
TPS6107x	0.6	0.9 to 5.5	0.9 to 5.5	90% Efficient Synchronous Boost Converter With 600-mA Switch	✓	SOT-23 3x3	0.45
TPS61260	0.7	0.8 to 4.0	1.8 to 4.0	Tiny Low Input Voltage Boost Converter with Adjustable Output Voltage		WSON 2x2	0.38
TPS61046	0.9	1.6 to 5.5	4.0 to 28	28-V Output Voltage Boost Converter in WCSP Package		WCSP 0.8x1.2	0.42
TLV61046A	1	1.8 to 5.5	3.3 to 28	28-V Output Voltage Boost Converter with Power Diode and Isolation Switch		SOT-23 3x3	0.35
TPS61099x	1	0.5 to 5.5	1.8 to 5.5	Synchronous Boost Converter with 800-nA Ultra-Low Quiescent Current		WCSP, QFN	0.58
TPS61291	1	0.9 to 5.0	2.5 to 3.3	Low Iq Boost Converter with 15-nA quiescent current in bypass mode		SON 2x2	0.58
LM5001	1	3.1 to 75	1.26 to 75	High-Voltage Switch-Mode Regulator	✓	SOIC 4.9x3.91	1.50
TPS61093	1.1	1.6 to 6.0	1.7 to 17.0	Low-Input Boost Converter With Integrated Power Diode and Input/Output Isolation	✓	SON 2.5x2.5	1.00
TPS61170	1.2	3.0 to 18	3.0 to 38	1.2-A High-Voltage Boost Converter in 2-mm x 2-mm2 QFN Package	✓	QFN 2x2	0.80
LM27313	0.8	2.7 to 14.0	4.0 to 28	1.6-MHz Boost Converter With 30-V Internal FET Switch in SOT-23	✓	SOT-23 3x3	0.60
TPS61252	1.5	2.3 to 6.0	3.0 to 6.5	Tiny 1.5-A Boost Converter With Adjustable Input Current Limit		WSON 2x2	0.65
TPS61020	1.5	0.9 to 6.5	1.8 to 5.5	96% Efficient Synchronous Boost Converter	✓	SON 3x3	0.78
TPS61200	1.5	0.3 to 5.5	1.8 to 5.5	0.3-V Input Voltage Boost Converter with 1.3-A Switches and 'Down Mode' in 3x3 QFN		VSON 3x3	0.90
TPS61081	1.5	2.5 to 6.0	2.5 to 27	27-V, 1.2-A switch, 1.2-MHz Boost Converter with integrated power diode		VSON 3x3	1.15
LM2733	1.5	2.7 to 14.0	4.0 to 40	0.6- and 1.6-MHz Boost Converters With 40-V Internal FET Switch in SOT-23		SOT-23 3x3	0.65
TPS61322x	1.8	0.9 to 4.5	1.8 to 5.5	6.5- μ A Quiescent Current, 1.8-A Switch Current Boost Converter		SOT-23 3x3	0.30
TPS61029	1.8	0.9 to 6.5	1.8 to 5.5	Adjustable, 1.8-A Switch, 96% Efficient Boost Converter with Down-Mode, QFN-10	✓	VSON 3x3	0.85
TPS61090	2	1.8 to 5.5	1.8 to 5.5	2-A Switch, 96% Efficient Boost Converter		VQFN 4x4	0.90
LM5000	2	3.1 to 40	1.3 to 75	3.1- to 40-V Wide Vin, 2-A Current Mode Non-Synchronous Boost Regulator		TSSOP, WSON	1.80
LM2735	2	2.7 to 5.5	3.0 to 24	520-kHz/1.6-MHz, Space-Efficient Boost and SEPIC DC-DC Regulator	✓	MSOP, SOT-23, WSON	0.75
TPS61256C	2.2	2.3 to 5.5	5.0 to 5.0	3.5-MHz High Efficiency Step-Up Converter In Chip Scale Packaging		WCSP 1.2x1.3	0.48
LM2623	2.85	0.8 to 14	1.24 to 14	0.8-V to 14-V Wide Input Range Boost Converter	✓	WSON, VSSOP	0.50
TPS61085	3	2.3 to 6.0	2.5 to 18.5	18.5-V, 2-A, 650-kHz/1.2-MHz Step-Up DC-DC Converter w/ Forced PWM Mode	✓	VSSOP, TSSOP	0.73
TPS61253A	4	2.3 to 5.5	5.0 to 5.0	3.8-MHz, 5-V/4-A Boost Converter in 1.2- x 1.3-mm WCSP		WCSP 1.2x1.3	0.45
TPS61030	4	1.8 to 5.5	1.8 to 5.5	96% Efficient Synchronous Boost Converter With 4-A Switch		QFN, TSSOP	1.15
TPS61021A	4	0.5-4.4	1.8 to 4.0	3-A Boost Converter with 0.5-V Ultra Low Input Voltage		WSON 2x2	0.58
TPS61259	4	2.3 to 5.5	4.5 to 5.2	3.5-MHz High Efficiency Step-Up Converter In Chip Scale Packaging		WCSP 1.2x1.3	0.48
TPS61087	4	2.5 to 6.0	2.5 to 18.5	18.5-V, 3.2-A, 650-kHz/1.2-MHz Step-Up DC-DC Converter with Forced PWM Mode	✓	VSON, WSON	0.78
TPS61175	4	2.9 to 18	2.9 to 38	3-A High Voltage Boost Converter with Soft-start and Programmable Switching Frequency	✓	HTSSOP 5x4.4	1.30
TPS61230	5	2.3 to 5.5	2.5 to 5.5	High-Efficiency Synchronous Step Up Converters with 5-A Switches		SON 3x3	0.95
TPS61280A	5	2.3 to 4.8	2.8 to 4.4	TPS6128xA Low Voltage Front-end Power Management IC		DSBGA 1.7x1.7	0.58
TPS55332-Q1	5.7	1.5 to 60	2.5 to 50	Automotive 1.5- to 60-V Wide Input Range, 3-A Boost Converter with Voltage Supervisor	✓	HTSSOP 6.5x4.4	2.46
TPS61230A	6	2.5 to 4.5	2.5 to 5.5	5-V/6-A High Efficiency Step-Up Converter		VQFN 2x2	0.68
TPS55340	6.6	2.9 to 38	3.0 to 38	Integrated 5-A Wide Input Range Boost/SEPIC/Flyback DC-DC Regulator	✓	WQFN HTSSOP	1.40
TPS61089	8	2.7 to 12.1	4.5 to 12.7	12.6-V, 7-A Fully-Integrated Synchronous Boost Converters, Adjustable Current Limit		VQFN 2x2.5	1.10
TPS61236P	8	2.3 to 5.5	2.5 to 5.5	3- to 5-V/3-A booster with 97% efficiency, adjustable current limit		QFN 2.5x2.5	0.78
TPS61022	8	0.5 to 5.5	2.2 to 5.5	7-A Boost Converter with 0.5-V Ultra-low Input Voltage		QFN 2.0x2.0	0.85
TPS61178	8	2.7 to 20	4.5 to 20	20-V Fully Integrated Sync Boost with Load Disconnect, Adjustable Current Limit		QFN 3.0x3.5	1.80
TPS61088	12	2.7 to 12.0	4.5 to 12.6	10-A peak current limit, 3.3- to 9-V/3-A booster, adjustable current limit	✓	QFN 3.5x4.5	1.60
TPS40210 ²	6	4.5 to 52	0.70 to 300	4.5-V to 52-V Input Current Mode Boost Controller	✓	HVSSOP, VSON	0.75
MC33063A ²	10	3.0 to 40	1.25 to 300	1.5-A Peak Boost/Buck/Inverting Switching Regulators	✓	SOIC, SON, PDIP	0.18
LM5020 ²	10	13 to 100	1.25 to 300	13- to 100-V Wide Vin, Current Mode PWM Boost Controller		VSSOP, WSON	1.00
LM5022 ²	10	3.0 to 60	1.25 to 300	2.2-MHz 60-V Low Side Controller for Boost, SEPIC and Flyback	✓	VSSOP 3.0x3.0	0.90
LM3478 ²	10	2.97 to 40	1.26 to 500	40-V Wide Vin Low-Side N-Channel Controller for Switching Regulator	✓	SOIC, VSSOP	0.75
TPS43060 ²	15	4.5 to 40	4.5 to 60	Low Iq, Synchronous Boost Controller with Wide Input Voltage and 7.5-V Gate Drive for Standard FETs		WQFN 3x3	1.25
LM5150-Q1 ²	15	1.5 to 42	6.8 to 10.5	Wide Vin Automotive Low Iq Boost Controller For Automotive Start-Stop System	✓	WQFN 4x4	0.85
LM5122 ²	20	3.0 to 65	3.0 to 100	Wide-Input Synchronous Boost Controller With Multiple Phase Capability	✓	HTSSOP 6.5x4.4	1.80
LM25122-Q1 ²	20	3.0 to 42	3.0 to 50	Automotive Grade, 3- to 42-V Wide Vin, Synchronous Boost Controller with Multiphase Capability	✓	HTSSOP 6.5x4.4	1.75
LM5121 ²	20	3.0 to 65	3 to 100	Wide Input Synchronous Boost Controller with Disconnection Switch Control	✓	HTSSOP 6.5x4.4	1.80

¹ Switch current is for boost and buck-boost. Output current is for charge pump.

² Designates controller device.

*Suggested resale price in U.S. dollars in quantities of 1,000.

New devices are listed in **bold red**.
Preview devices are listed in **bold teal**.

Non-Isolated DC/DC Switching Regulators

Step-Up (Boost)

Step-Up Regulators (Up to 10-A Switch Limit) (Continued)

Device	Output/Switch Current ¹ (A)	Input Voltage (V)	Output Voltage (V)	Features	Automotive Grade	Package(s)	Price*
Buck-Boost							
TPS5065-Q1	1.5	1.5 to 40	5.0 to 5.0	Automotive 1.5 V to 40 V, 500-mA Buck/Boost Converter with 5-V Fixed Output Voltage	✓	HTSSOP 6.5x4.4 mm	1.55
TPIC74100-Q1	3.5	1.5 to 40	5.0 to 5.0	Automotive 1.5 V to 40 V, 1A Buck/Boost Converter with 5-V Fixed Output Voltage	✓	HTSSOP 6.5x4.4 mm	1.70
TPS5516x-Q1	3.5	2.0 to 36	5.0 to 12.0	36-V, 1-A Output, 2-MHz, Single Inductor, Synchronous Buck/Boost Voltage Regulator	✓	HTSSOP 6.5x4.4 mm	1.95
LM25118 ²	10.0	3.0 to 42	1.23 to 38	3–42-V Wide Vin, Current Mode Non-Synchronous Buck-Boost Controller	✓	HTSSOP 6.5x4.4 mm	2.00
LM5118 ²	10.0	3.0 to 75	1.25 to 70	3–75-V Wide Vin, Current Mode Non-Synchronous Buck-Boost Controller	✓	HTSSOP 6.5x4.4 mm	2.38
LM5175 ²	20.0	3.5 to 42	0.8 to 55	42-V Wide VIN Synchronous 4-Switch Buck-Boost Controller	✓	HTSSOP QFN	3.10
LM5176 ²	20.0	2.5 to 55	0.8 to 55	55-V Wide VIN Synchronous 4-Switch Buck-Boost Controller	✓	HTSSOP 9.7x4.4 mm	3.00
LM5170-Q1 ²	40.0	3.0 to 100	3.0 to 100	Multiphase Bidirectional Current Controller	✓	TQFP 7x7 mm	5.84
Charge Pumps							
LM2664	0.04	1.8 to 5.5	–1.8 to –5.0	Switched Capacitor Voltage Converter		SOT23 3x3 mm	0.27
TPS60150	0.14	2.7 to 5.5	5.0 to 5.0	5-V, 140-mA Charge-Pump		WSON 2x2 mm	0.50
LM2775	0.2	2.7 to 5.5	5.0 to 5.0	Switched Capacitor 5-V Boost Converter	✓	WSON 2x2 mm	0.47
TPS6024x	0.02	1.8 to 5.5	2.7 to 5.0	170-µVrms Zero-Ripple Switched Capacitor Buck-Boost Converter for VCO Supply		VSSOP 3x3 mm	0.55
TPS6031x	0.02	0.9 to 1.8	3.0 to 3.3	Single-Cell to 3-V/3.3-V, 20mA Dual Output, High-efficiency Charge Pump With Snooze Mode		MSOP 3x3 mm	0.65

¹Switch current is for boost and buck-boost. Output current is for charge pump.

²Designates controller device.

*Suggested resale price in U.S. dollars in quantities of 1,000.

New devices are listed in **bold red**.
Preview devices are listed in **bold teal**.

Device ¹	Switch Current Limit (typ) (mA)	V _{IN} (V)	V _{OUT} Adj. (V)	V _{OUT} Fixed (V)	Peak Efficiency (%)	Switching Frequency (typ) (kHz)	Recommended Inductor Size (µH)	Quiescent Current (typ) (µA)	Shutdown Current (typ) (µA)	Integrated LDO I _{OUT} (mA)/V _{OUT} (V)	Synchronous Rectification	Features ²	Package(s)	EVM	Price*
Step-Up (Boost) Regulators with Integrated LDO (Dual Output)															
TL499A	—	1.1 to 10	2.9 to 30	—	85	—	—	—	15	100/Adj.			8 SOIC		1.20
TPS61120	1300	1.8 to 5.5	2.5 to 5.5	—	95	500	10	20	0.2	200/Adj.	✓	PG, LBI, UVLO	16 TSSOP, (4x4) QFN	✓	1.65
TPS61121	1300	1.8 to 5.5	—	1.5, 3.3	95	500	10	20	0.2	200/1.5	✓	PG, LBI, UVLO	16 TSSOP, (4x4) QFN		2.00

¹All devices listed have thermal and/or short-circuit protection except TL499A.

²UVLO = undervoltage lockout; LBI = low-battery indicator; PG = Power Good.

*Suggested resale price in U.S. dollars in quantities of 1,000.

Inverting Regulators

Device ¹	Switch Current Limit (typ) (mA)	V _{IN} (V)	V _{OUT} Adj. (V)	V _{OUT} Fixed (V)	Peak Efficiency (%)	Switching Frequency (typ) (kHz)	Recommended Inductor Size (µH)	Quiescent Current (typ) (µA)	Shutdown Current (typ) (µA)	Integrated LDO I _{OUT} (mA)/V _{OUT} (V)	Synchronous Rectification	Features ²	Package(s)	EVM	Price*
LMR70503	300	2.8 to 5.5	–0.9 to –5.5	—	79	500	—	0.245 mA	0.01	—		UVLO	(1.64x0.86) CSP	✓	1.15
TL497A	500	4.5 to 12	–1.2 to –25	—	85	—	—	11 mA	6000	—			14 TSSOP, 14 SOIC		0.90
TPS63700	1000	2.7 to 5.5	–2 to –15	—	84	1400	4.7	330	0.2	—		UVLO	(3x3) SON	✓	0.79
MC34063A	1500	3 to 38	–1.25 to –36.3	—	—	100	—	330	0.2	—		UVLO	8 SOIC, (4x4 mm) QFN	✓	0.21
TPS63710	2100	3.1 to 14	–1 to –5.5	—	91	1500	2.2	15 mA	5	—	✓	Low 1/f-noise reference system	(3x3) SON		1.30

¹All devices listed have thermal and/or short-circuit protection except TL497A.

²UVLO = undervoltage lockout.

*Suggested resale price in U.S. dollars in quantities of 1,000.

New devices are listed in **bold red**.

Non-Isolated DC/DC Switching Regulators

Buck/Boost, Inverting or Split-Rail

Buck/Boost Converters (Integrated Switch)

Device	I_{OUT}^1 (mA)	Switch-Current Limit (typ) (mA)	V_{IN} (V)	V_{OUT} Adj. (V)	V_{OUT} Fixed (V)	Peak Efficiency (%)	Switching Frequency (typ) (kHz)	Recommended Inductor Size (μ H)	Quiescent Current (typ) (μ A)	Shutdown Current (typ) (μ A)	Adj. Input-Current Limit	Load Disconnect During Shutdown	Synch. to Ext. CLK Pin	Power Good Pin	Undervoltage Lockout	Package(s)	EVM	Automotive Grade	Price*
LM2611	300	1200	2.7 to 14	—	-5	96	1400	22	270	0.01					✓	SOT-23	✓		0.95
TPS61130	300	1300	1.8 to 6.5	2.5 to 5.5	1.5, 3.3	90	500	22	40	0.2		✓		✓	✓	QFN, TSSOP	✓		1.63
TPS55065-Q1	500	2500	1.5 to 40	—	5	83	440	33	100	10				✓	✓	20 HTSSOP	✓	✓	1.55
TPS63030	500	1000	1.8 to 5.5	1.2 to 5.5	3.3	96	2400	2.2	29	0.1		✓	✓		✓	10 QFN	✓		0.72
TPS63050²	500	1000	2.5 to 5.5	2.5 to 5.5	3.3	96	2500	1.5	43	0.1	✓	✓		✓	✓	12 WCSP, HotRod™ QFN	✓		0.70
TPS63000	800	1800	1.8 to 5.5	1.2 to 5.5	3.3, 5.0	90	1400	2.2	30	0.1		✓	✓		✓	10 QFN	✓	✓	0.85
TPS63010	800	2200	2 to 5.5	1.2 to 5.5	2.8, 2.9, 3.3, 3.4	96	2400	1.5	40	0.1		✓	✓		✓	20 WCSP	✓		0.86
TPIC74100-Q1	1000	2500	1.5 to 40	—	5	83	440	33	100	10				✓	✓	20 HTSSOP	✓	✓	1.70
TPIC74101-Q1	1000	2500	1.5 to 40	—	5	83	380	33	110	10				✓	✓	20 HTSSOP	✓	✓	1.70
TPS55165-Q1	1000	3500	2 to 36	5.7 to 9	5, 12	85	2000	4.7	10	1		✓		✓	✓	20 HTSSOP	✓	✓	2.20
LM3668	1000	1850	2.8 to 5.5	2.8 to 5	2.8, 3.3	96	2200	2.2	45	0.01			✓		✓	12 QFN	✓		2.25
TPS63060	1300	2250	2.5 to 12	2.5 to 8	5	93	2400	1	37	0.3		✓	✓	✓	✓	10 SON	✓		0.90
TPS63024	1500	3000	2.3 to 5.5	2.3 to 3.6	2.9/3.3	97	2500	1	35	0.1		✓			✓	20 WCSP	✓		0.87
TPS63070	2000	3600	2.0 to 16	2.5 to 9	5	97	2400	1.5	54	2		✓	✓	✓	✓	15 QFN	✓		1.00
TPS630250	2000	4500	2.3 to 5.5	2.3 to 3.6	2.9/3.3	97	2500	1	35	0.1		✓			✓	20 WCSP, 14 QFN	✓		1.05
TPS63020	2000	4000	1.8 to 5.5	1.2 to 5.5	3.3	96	2400	1.5	30	0.1		✓	✓	✓	✓	14 QFN	✓	✓	1.10
TPS63027	2000	4500	2.3 to 5.5	1.0 to 5.5	—	96	2500	1	35	0.1		✓			✓	25 WCSP	✓		1.05

¹ $V_{OUT} = 3.3 V$, boost mode

²Adjustable average input-current limit and soft start.

*Suggested resale price in U.S. dollars in quantities of 1,000.

New devices are listed in bold red.

Buck/Boost or Inverting Controllers (External Switch)

Device	V_{IN} (min/max) (V)	V_O (min/max) (V)	Frequency Range (kHz)	f_{sync}	On/Off Pin	Topology	Package(s)	Price*
LM5020	13/100	Set by external feedback network	50 to 1000	✓	✓	Flyback, inverting, buck, boost, forward	10 MSOP, 10 LLP	0.99
LM(2)5118	3.0/(42/75)	1.23/38 or 70	50 to 500	✓	✓	Buck-boost	20 eTSSOP	2.00/2.38
LM5175	3.5/42	0.8/55	100 to 600	✓	✓	Synchronous buck-boost	28 HTSSOP	4.25
LM5176	3.5/60	0.8/55	100 to 600	✓	✓	Synchronous buck-boost	28 HTSSOP	3.00
SM72442	4.75/5.25	—	220	—	—	Buck-boost	28 TSSOP	3.95
SM72445	4.75/5.25	—	110, 135 or 215	—	—	Buck-boost	28 TSSOP	3.95

*Suggested resale price in U.S. dollars in quantities of 1,000.

New devices are listed in bold red.

Split-Rail (+ V_{POS} /- V_{NEG}) Integrated Solutions

Device	V_{IN}		$-V_{NEG}$		$+V_{POS}$		I_{OUT} (max) (mA)	Package(s)	Automotive Grade	Price*
	(min) (V)	(max) (V)	(min) (V)	(max) (V)	(min) (V)	(max) (V)				
LM27762	2.7	5.5	-5	-1.5	5	1.5	250	SON		0.79
TPS65130	2.7	5.5	-15	-2	3.2	15	300	QFN		1.10
TPS65131	2.7	5.5	-15	-2	3.2	15	750	QFN		1.20
TPS65131-Q1	2.7	5.5	-15	-2	3.2	15	750	QFN	✓	1.40
TPS65132	2.5	5.5	-6	-4	4	6	150	CSP, QFN		0.45
TPS65133	2.9	5	-5	-5	5	5	250	SON		0.95
TPS65135	2.5	5.5	-7	-2.5	3	6	80	QFN		0.90

*Suggested resale price in U.S. dollars in quantities of 1,000.

Non-Isolated DC/DC Switching Regulators

Buck/Boost, Inverting or Split-Rail

Buck/Boost or Inverting Charge Pumps (Inductorless)

Device	I _{OUT} (mA)	V _{IN} (V)	V _{OUT} Adj. (V)	V _{OUT} Fixed (V)	Efficiency (%)	Switching Frequency (max) (kHz)	Quiescent Current (typ) (μA)	Shutdown Current (typ) (μA)	Features						Package(s)	EVM	Automotive Grade	Price*
									Shutdown	Low Battery	Power Good	Undervoltage Lockout	Current Limit	Thermal Limit				
Buck-Boost Regulators																		
REG710	30	1.8 to 5.5	—	2.5 to 5.0	90	1000	65	0.01	✓				✓	✓	SOT-23	✓	0.43	
REG71050	60	2.7 to 5.5	—	5.0	90	1000	65	0.01	✓				✓	✓	TSOT-23, TQFN-6	✓	0.43	
REG711	50	1.8 to 5.5	—	2.5 to 5.0	90	1000	60	0.01	✓				✓	✓	MSOP-8		0.39	
TPS60240	25	1.8 to 5.5	—	3.3	90	160	250	0.1	✓				✓	✓	MSOP-8		0.55	
Inverting Regulators																		
LM2776	200	2.7 to 5.5	—	-V _{IN}	92	2000	100	0.1	✓			✓	✓	✓	SOT-23	✓	0.35	
LM27761	250	2.7 to 5.5	-5.0 to -1.5	—	92	2000	370	7	✓			✓	✓	✓	WSO-8	✓	0.67	
LM27762	250	2.7 to 5.5	±1.5 to ±5	—	86	2000	390	0.5	✓			✓	✓	✓	WSO-12	✓	0.79	
LM2660	100	2.5 to 5.5	—	2V _{IN}	88	10, 80	120	—							SO-8		0.50	
LM2662/3	200	2.5 to 5.5	—	2V _{IN}	86	20, 150	300	10		LM2663					SO-8		0.75	
TPS60400	60	1.6 to 5.5	—	-V _{IN}	95	50 to 250	125	—							SOT-23	✓	0.43	
TPS60401	60	1.6 to 5.5	—	—	98	20	65	—							SOT-23	✓	0.43	
TPS60402	60	1.6 to 5.5	—	—	97	50	120	—							SOT-23	✓	0.43	
TPS60403	60	1.6 to 5.5	—	—	95	250	425	—							SOT-23	✓	0.43	
LMC7660	20	1.5 to 10	-10 to -1.5	—	97	10	120	—							SOIC-8, PDIP-8		0.35	

¹Device parameter, feature and/or price may vary with each device number in family.

*Suggested resale price in U.S. dollars in quantities of 1,000.

Power Modules Overview

Design with TI's comprehensive power module portfolio for wide input-voltage and output-current ranges, flexible packaging options and easy-to-use integrated solutions for a variety of non-isolated, industrial, medical, and communications applications.



Open-Frame PTH08T2xx "T2" Power Modules

High-current modules for applications that require up to 50 A.

- High output current of up to 50 A
- TurboTrans™ feature for tunable transient response
- Current sharing (50-A version)



QFN Power Modules

Easy-to-use high-power-density modules for applications requiring a small footprint.

- Input-voltage range: 2.95 to 60 V
- Output current up to 30 A
- Feature-rich and flexible
- Only three external components required

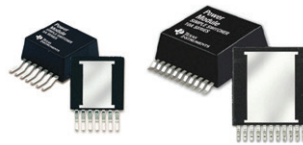

Leaded SIMPLE SWITCHER® Modules

Easy-to-use modules for applications requiring high input voltages of up to 42 V.

- Single exposed bottom
- Supports 5-V, 12-V and 24-V rails
- Output current up to 10 A

MicroSiP™ Modules

Smallest total-solution footprint.

- With integrated caps and inductor: Like TPS826x family (6 MHz) and TPS82740
- With integrated inductor only: Like TPS82084/85 (6-V input) and TPS82130/40/50 (17-V input)
- Ultra-low power, like TPS82740 with only 360-nA I_Q (operating)
- Up to 36-V input with LMZM23601



TI's power modules include all the key components needed to implement a DC/DC power solution that can simplify design, reduce solution size and lower development time. Products have voltages up to 60 V and currents up to 50 A. For more information, visit www.ti.com/powermodules

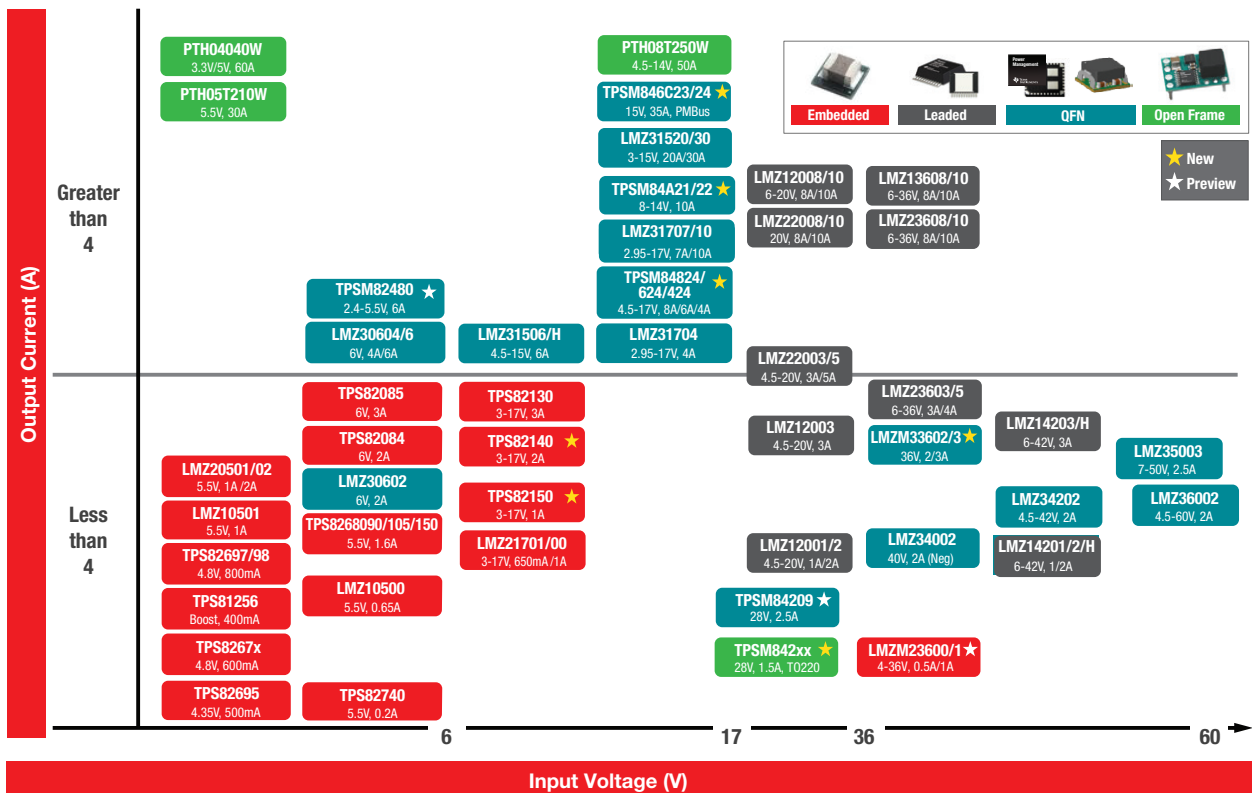

Power Modules

Non-Isolated Modules

Open-Frame Power Modules (POLA™ and Others)

Input Voltage, V_{IN}	24 V	PTN78000	PTN78060	PTN78060	PTN78020						
	12 V	PTN78000	PTN78060 PTH08000 PTH08080	PTH08T260 PTN78060	PTH08T230 PTN78020	PTH08T230 PTH12000 PTH12050 PTV12010 PTR08060	PTH08T240 PTH12060 PTH12010 PTV12020	PTH08T220 PTH12020	PTH08T210 PTH12030	PTH08T250 PTV08040 PTH12040	
	5 V	PTN04050	PTH04000 PTH04070	PTH04T260 PTH04000 PTH04070	PTH04T230 PTH05000	PTH04T230 PTH05050 PTV05010 PTR08060	PTH04T240 PTH05060 PTH05010 PTR08100	PTH04T220 PTH05020 PTV05020	PTH05T210 PTH05030	PTH08T250 PTH04040	
	3.3 V		PTH04000 PTH04070	PTH04T260 PTH04000 PTH04070	PTH04T230 PTH03000	PTH04T230 PTH03050 PTV03010	PTH04T240 PTH03060 PTH03010	PTH04T220 PTH03020 PTV03020	PTH03030	PTH04040	
		1 A	2 A	3 A	5 A	8 A	15 A	20 A	30 A	60 A	
		Output Current, I_{OUT}									

Open-Frame Buck and Boost Modules

Device ¹	Input Bus Voltage	Description	P_{OUT} or I_{OUT}	V_O Range (V)	V_O Adj.	Auto-Track™ Sequencing	POLA™	DDR-QDR	Price*
PTH03000W	3.3 V	3.3-V Input 6-A POL	6 A	0.8 to 2.5	✓				7.59
PTH03010W	3.3 V	3.3-V Input 15-A POL with Auto-Track™ Sequencing	15 A	0.8 to 2.5	✓	✓	✓		14.04
PTH03020W	3.3 V	3.3-V Input 22-A POL with Auto-Track Sequencing	22 A	0.8 to 2.5	✓	✓	✓		18.15
PTH03030W	3.3 V	3.3-V Input 30-A POL with Auto-Track Sequencing	30 A	0.8 to 2.5	✓	✓	✓		20.57
PTH03050W	3.3 V	3.3-V Input 6-A POL with Auto-Track Sequencing	6 A	0.8 to 2.5	✓	✓	✓		8.35
PTH03060W	3.3 V	3.3-V Input 10-A POL with Auto-Track Sequencing	10 A	0.7 to 2.5	✓	✓	✓		11.86
PTH04000W	3.3 V/5 V	3-V to 5.5-V Input 3-A POL with Auto-Track Sequencing	3 A	0.9 to 3.6	✓	✓	✓		5.45
PTH04070W	3.3 V/5 V	3-V to 5.5-V Input 3-A POL	3 A	0.9 to 3.6	✓				4.71
PTH04040W	3.3 V/5 V	3-V to 5.5-V Input 60-A POL with Auto-Track Sequencing	60 A	0.8 to 3.6	✓	✓	✓		52.94
PTH04T220/221W	3.3 V/5 V	2.2- to 5.5-V Input, 16-A T2 2nd Gen PTH POL with TurboTrans™	16 A	0.7 to 3.6	✓	✓	✓		13.86
PTH04T230/231W	3.3 V/5 V	2.2- to 5.5-V Input, 6-A T2 2nd Gen PTH POL with TurboTrans	6 A	0.7 to 3.6	✓	✓			8.69
PTH04T240/241W	3.3 V/5 V	2.2- to 5.5-V Input, 10-A T2 2nd Gen PTH POL with TurboTrans	10 A	0.7 to 3.6	✓	✓			11.88
PTH04T260/261W	3.3 V/5 V	2.2- to 5.5-V Input, 6-A T2 2nd Gen PTH POL with TurboTrans	3 A	0.7 to 3.6	✓	✓			6.88
PTH05000W	5 V	5-V Input 6-A POL	6 A	0.8 to 3.6	✓				7.59
PTH05010W	5 V	5-V Input 15-A POL with Auto-Track Sequencing	15 A	0.8 to 3.6	✓	✓	✓		14.04
PTH05020W	5 V	5-V Input 22-A POL with Auto-Track Sequencing	22 A	0.8 to 3.6	✓	✓	✓		18.15
PTH05030W	5 V	5-V Input 30-A POL with Auto-Track Sequencing	30 A	0.8 to 3.6	✓	✓	✓		20.57
PTH05050W	5 V	5-V Input 6-A POL with Auto-Track Sequencing	6 A	0.8 to 3.6	✓	✓	✓		8.35
PTH05060W	5 V	5-V Input 10-A POL with Auto-Track Sequencing	10 A	0.8 to 3.6	✓	✓	✓		11.86
PTH05T210W	5 V	5-V Input, 30-A T2 2nd Gen PTH POL with TurboTrans	30 A	0.7 to 3.6	✓	✓	✓		27.23
PTH08000W	5 V/12 V	4.5-V to 18-V Input, 2.25-A POL with Auto-Track Sequencing	2.25 A	0.9 to 5.5	✓	✓	✓		5.45
PTH08080W	5 V/12 V	4.5-V to 18-V Input, 2.25-A POL	2.25 A	0.9 to 5.5	✓				4.71
PTH08T210W	12 V	5.5- to 14-V Input, 30-A T2 2nd Gen PTH POL with TurboTrans	30 A	0.7 to 3.6	✓	✓	✓		21.78
PTH08T220/221W	5 V/12 V	4.5- to 14-V Input, 16-A T2 2nd Gen PTH POL with TurboTrans	16 A	0.7 to 5.5	✓	✓	✓		15.25
PTH08T230/231W	5 V/12 V	4.5- to 14-V Input, 6-A T2 2nd Gen PTH POL with TurboTrans	6 A	0.7 to 5.5	✓	✓			8.69
PTH08T240/241W	5 V/12 V	4.5- to 14-V Input, 10-A T2 2nd Gen PTH POL with TurboTrans	10 A	0.7 to 5.5	✓	✓			13.07
PTH08T240F	5 V/12 V	4.5- to 14-V Input, 10-A T2 2nd Gen PTH POL for 3-GHz DSP Systems	10 A	0.7 to 2.0	✓	✓	✓		13.07
PTH08T250/255W	5 V/12 V	4.5- to 14-V Input, 50-A T2 2nd Gen PTH POL with TurboTrans	50 A	0.7 to 5.5	✓	✓	✓		43.56
PTH08T260/261W	5 V/12 V	4.5- to 14-V Input, 3-A T2 2nd Gen PTH POL with TurboTrans	3 A	0.7 to 5.5	✓	✓			6.88
PTH12000L/W	12 V	12-V Input 6-A POL	6 A	0.8 to 1.8/1.2 to 5.5	✓				7.59
PTH12010L/W	12 V	12-V Input 12-A POL with Auto-Track Sequencing	12 A	0.8 to 1.8/1.2 to 5.5	✓	✓	✓		14.04
PTH12020L/W	12 V	12-V Input 18-A POL with Auto-Track Sequencing	18 A	0.8 to 1.8/1.2 to 5.5	✓	✓	✓		18.15
PTH12030L/W	12 V	12-V Input 26-A POL with Auto-Track Sequencing	26 A	0.8 to 1.8/1.2 to 5.5	✓	✓	✓		25.72
PTH12040W	12 V	12-V Input 50-A POL with Auto-Track Sequencing	50 A	0.8 to 5.5	✓	✓	✓		42.35
PTH12050L/W	12 V	12-V Input 6-A POL with Auto-Track Sequencing	6 A	0.8 to 1.8/1.2 to 5.5	✓	✓	✓		8.35
PTH12060L/W	12 V	12-V Input 10-A POL with Auto-Track Sequencing	10 A	0.8 to 1.8/1.2 to 5.5	✓	✓	✓		11.86

¹See www.ti.com/power for a complete product offering.

*Suggested resale price in U.S. dollars in quantities of 1,000.

Power Modules

Non-Isolated Modules

Open-Frame Buck and Boost Modules (Continued)

Device ¹	Input Bus Voltage	Description	P _{OUT} or I _{OUT}	V _O Range (V)	V _O Adj.	Auto-Track™ Sequencing	POLA™	DDR-QDR	Price*
PTH03010Y	3.3 V	3.3-V Input 15-A DDR Terminating Module	15 A	Follows V _{REF}	✓		✓	✓	17.55
PTH03050Y	3.3 V	3.3-V Input 6-A DDR Terminating Module	6 A	Follows V _{REF}	✓		✓	✓	8.35
PTH03060Y	3.3 V	3.3-V Input 10-A DDR Terminating Module	10 A	Follows V _{REF}	✓		✓	✓	11.86
PTH05010Y	5 V	5-V Input 15-A DDR Terminating Module	15 A	Follows V _{REF}	✓		✓	✓	17.55
PTH05050Y	5 V	5-V Input 6-A DDR Terminating Module	6 A	Follows V _{REF}	✓		✓	✓	10.44
PTH05060Y	5 V	5-V Input 10-A DDR Terminating Module	10 A	Follows V _{REF}	✓		✓	✓	14.83
PTH12010Y	12 V	12-V Input 12-A DDR Terminating Module	12 A	Follows V _{REF}	✓		✓	✓	17.55
PTH12050Y	12 V	12-V Input 6-A DDR Terminating Module	6 A	Follows V _{REF}	✓		✓	✓	10.44
PTH12060Y	12 V	12-V Input 8-A DDR Terminating Module	8 A	Follows V _{REF}	✓		✓	✓	14.83
PTN04050C	3.3 V/5 V	3-V/5-V Input, 12-W Output Step-Up (Boost) ISR	12 W	5 to 15	✓				10.89
PTN78000W/H	V _O + 2 to 36 V	Wide-Input, Wide-Output 1.5-A Positive Step-Down ISR	1.5 A	2.5 to 12/12 to 22	✓				9.08
PTN78060W/H	V _O + 2 to 36 V	Wide-Input, Wide-Output 3-A Positive Step-Down ISR	3 A	2.5 to 12/12 to 22	✓				13.31
PTN78020W/H	V _O + 2 to 36 V	Wide-Input, Wide-Output 6-A Positive Step-Down ISR	6 A	2.5 to 12/12 to 22	✓				16.94
PTR08060W	5 V/12 V	4.5- to 14-V Input, 6-A POL	6 A	0.6 to 5.5	✓				6.00
PTR08100W	5 V/12 V	4.5- to 14-V Input, 10-A POL	10 A	0.6 to 5.5	✓				8.00
PTV03010W	3.3 V	5-V Input 8-A Vertical SIP with Auto-Track Sequencing	8 A	0.8 to 2.5	✓	✓	✓		10.44
PTV03020W	3.3 V	5-V Input 18-A Vertical SIP with Auto-Track Sequencing	18 A	0.8 to 2.5	✓	✓	✓		17.55
PTV05010W	5 V	5-V Input 8-A Vertical SIP with Auto-Track Sequencing	8 A	0.8 to 3.6	✓	✓	✓		10.44
PTV05020W	5 V	5-V Input 18-A Vertical SIP with Auto-Track Sequencing	18 A	0.8 to 3.6	✓	✓	✓		17.55
PTV08T250W	12 V	8-V to 14-V Input, 50-A T2 2nd Gen PTH POL with TurboTrans	50 A	0.8 to 3.6	✓	✓			48.13
PTV12010L/W	12 V	12-V Input 8-A Vertical SIP with Auto-Track Sequencing	8 A	0.8 to 1.8/1.2 to 5.5	✓	✓	✓		10.44
PTV12020L/W	12 V	12-V Input 18-A Vertical SIP with Auto-Track Sequencing	16 A	0.8 to 1.8/1.2 to 5.5	✓	✓	✓		14.04

¹See www.ti.com/power for a complete product offering.

*Suggested resale price in U.S. dollars in quantities of 1,000.

QFN and MicroSiP™ Power Modules

Device	I _{OUT} (A)	V _{IN} (V)	V _{OUT} (V)	Peak Efficiency (%)	Features	Switching Frequency (kHz)	Quiescent Current (μA)	Shutdown Current (typ) (μA)	CISPR22 Class B EMI	PMBus	Package Type	Package Size (mm)	Price*
Low Input Voltage (2.3 to 6 V)													
TPS82740A	0.2	2.2 to 5.5	1.8 to 2.5	95	EN, light load, fixed V _{out} , int Cin/Cout	2000	0.36	0.07	No		Embedded	2.3 x 2.9 x 1.1	1.30
TPS82740B	0.2	2.2 to 5.5	2.6 to 3.3	95	EN, light load, fixed V _{out} , int Cin/Cout	2000	0.36	0.07	No		Embedded	2.3 x 2.9 x 1.1	1.30
TPS82695	0.5	2.3 to 5.5	2.5 to 2.85	95	EN, light load, fixed V _{out} , int Cin/Cout	4000	24	0.5	No		Embedded	2.3 x 2.9 x 1.0	0.92
TPS82671	0.6	2.3 to 4.8	1.0 to 1.9	90	Spread spectrum, int Cin/Cout	5500	17	0.5	No		Embedded	2.3 x 2.9 x 1.0	0.94
LMZ10500/1	0.65/1	2.7 to 5.5	0.6 to 3.6	95	EN, SS	2000	6500	11	Yes		Embedded	2.6 x 3 x 1.5	1.30/1.50
TPS81256	0.7	2.5 to 5.5	5	91	Boost Converter; True load disconnect, int Cin/Cout	4000	37	5	No		Embedded	2.6 x 2.9 x 1.0	1.10
TPS82693	0.8	2.3 to 4.8	2.2 to 3.2	95	Spread spectrum, int Cin/Cout	3000	21	0.5	No		Embedded	2.3 x 2.9 x 1.0	1.05
LMZ20501/2	1/2	2.7 to 5.5	0.8 to 3.6	91	EN, SS, PG, Eco-mode™	3000	64	1	Yes		Embedded	3.5 x 3.5 x 1.75	1.70/1.90
TPS8268180	1.6	2.5 to 1.5	0.9 to 1.8	90	Spread spectrum, int Cin/Cout	3000	7000	0.5	No		Embedded	2.3 x 2.9 x 1.0	1.20
LMZ30602/4/6	2/4	2.95 to 6	0.8 to 3.6	96	PG, Sync, SS	500 to 2000	—	70	Yes		QFN	9 x 11 x 2.8	2.95/3.80/4.50
TPS82084	2	2.5 to 6	0.8 to 6	95	EN, PG, Light Load	2400	17	0.7	No		Embedded	2.8 x 3.0 x 1.3	1.44
TPS82085	3	2.5 to 6	0.8 to 6	95	EN, PG, Light Load	2400	17	0.7	No		Embedded	2.8 x 3.0 x 1.3	1.65
LMZ10503/04/05	3/4/5	2.95 to 5.5	0.8 to 5	96	EN, SS	750 to 1160	5200	260	Yes		TO-PMOD-7	—	3.95/4.50/4.94
TPSM82480	6	2.4 to 5.5	0.6 to 5	96	EN, PG, SS/TR, VSEL, MODE, ThermalGood	2200	23	0.5	No		QFN	3.6 x 7.9 x 1.5	3.10
Mid Input Voltage (2.95 to 28 V)													
LMZ21700/1	0.65/1	3 to 17	0.9 to 6	95	EN, SS, PG, Eco-mode	2000	17	1.5	Yes		Embedded	3.5 x 3.5 x 1.75	1.55/1.75
TPS82150	1	3 to 17	0.9 to 6	95	EN, SS/TR, light load	2000	20	1.5	No		Embedded	2.8 x 3.0 x 1.5	1.50
TPS82140	2	3 to 17	0.9 to 6	95	EN, SS/TR, light load	2000	20	1.5	No		Embedded	2.8 x 3.0 x 1.5	1.65
TPSM84209	2	4.5 to 28	1.2 to 6	—	EN	750	—	—	—		QFN	4 x 4.5 x 2	2.10
TPS82130	3	3 to 17	0.9 to 6	95	EN, SS/TR, light load	2000	20	1.5	No		Embedded	2.8 x 3.0 x 1.5	1.82
LMZ12001/02/03	1/2/3	4.5 to 20	0.8 to 6	92	EN, SS	1000	1000	25	Yes		TO-PMOD-7	—	4.46/5.10/5.94
LMZ12001/02/03EXT	1/2/3	4.5 to 20	0.8 to 6	92	EN, SS, Extended Temp	1000	—	—	Yes		TO-PMOD-7	—	9.50/11.40/13.79
LMZ31503/6	3/6	4.5 to 14.5	0.8 to 5.5	94	PG, Sync, SS	330 to 780	—	2	Yes		QFN	9 x 15 x 2.8	4.25/5.45
TPSM84424	4	4.5 to 17	0.6 to 10	94	PG, Sync, SS	200 to 1000	580	3	Yes		QFN	7.5 x 7.5 x 5.3	3.95

*Suggested resale price in U.S. dollars in quantities of 1,000.

New devices are listed in bold red.

Power Modules

Non-Isolated Modules

QFN and MicroSiP™ Power Modules (Continued)

Device	I _{OUT} (A)	V _{IN} (V)	V _{OUT} (V)	Peak Efficiency (%)	Features	Switching Frequency (kHz)	Quiescent Current (μA)	Shutdown Current (typ) (μA)	CISPR22 Class B EMI	PMBus	Package Type	Package Size (mm)	Price*
Mid Input Voltage (2.95 to 28 V) (Continued)													
LMZ31704/7/10	4/7/10	2.95 to 17	0.6 to 5.5	95	PG, Sync, SS, Current Share	200 to 1200	—	2	Yes		QFN	10 x 10 x 4.3	5.25/6.5/8.95
LMZ22003/5	3/5	6 to 20	0.8 to 5	92	EN, SS, Freq Sync	650 to 950	—	—	Yes		TO-PMOD-7	—	5.50/6.25
TPSM84824	8	4.5 to 17	0.6 to 10	94	PG, Sync, SS	200 to 1000	580	3	Yes		QFN	7.5 x 7.5 x 5.3	4.95
LMZ12008/10	8/10	6 to 20	0.8 to 6	92	EN, SS	—	2600	70	Yes		TO-PMOD-11	—	9.25/10.5
TPSM84A21/2	10	8 to 14	0.55 to 2.05	86	PG, Sync, SS	4000	—	—	Yes		QFN	9 x 15 x 2.3	7.50
LMZ31520/30	20/30	4.5 to 14.5	0.6 to 2.8	95	PG, SS	300 to 850	—	0.7	Yes		QFN	15 x 16 x 5.8	14.00/17.00
TPSM846C23	35	4.5 to 15	0.35 to 2	94	PG, Sync, SS, Current Share	300 to 1000	—	—	Yes	Yes	QFN	15 x 16 x 6.4	14.00
TPSM846C24	35	4.5 to 15	0.35 to 2	94	PG, Sync, SS, Current Share	300 to 1000	—	—	Yes		QFN	15 x 16 x 6.4	12.75
Wide Input Voltage (4 to 60 V)													
LMZM23600/1	0.5/1	4 to 36	2.5 to 15/ 5/3.3	95	EN, Fixed Vout, FPWM/PFM Mode, Sync	750/1000	30	2	Yes		Embedded	3.0 x 3.8 x 1.6	1.95/2.40
LMZ14201H/02H/03H	1/2/3	6 to 42	5 to 24	97	EN, SS, Wide Vout	up to 1000	1000	25	Yes		TO-PMOD-7	—	6.18/7.13/8.95
LMZM33602/3	2/3	4 to 36	1 to 18		PG, Sync, SS	200 to 1200	—	—	Yes		QFN	7 x 9 x 4	4.95/4.20
LMZ34002	2	4.5 to 40	-3 to -17	86	PG, Sync, SS	400 to 900	—	1.3	Yes		QFN	9 x 11 x 2.8	6.75
LMZ34202	2	4.5 to 42	2.5 to 7.5	95	PG, Sync, SS	200 to 1000	—	2.4	Yes		QFN	10 x 10 x 4.3	4.60
LMZ36002	2	4.5 to 60	2.5 to 7.5	95	PG, Sync, SS	200 to 1000	—	2.4	Yes		QFN	10 x 10 x 4.3	5.60
LMZ35003	2.5	7 to 50	2.5 to 15	93	PG, Sync, SS	400 to 1000	—	1.3	Yes		QFN	9 x 11 x 2.8	7.95
LMZ23603/5	3/5	6 to 36	0.8 to 6	92	EN, SS, Freq Sync	650 to 950	2600	70	Yes		TO-PMOD-7	—	9.85/12.50
LMZ13608/10	8/10	6 to 36	0.8 to 6	92	EN, SS	—	3000	32	Yes		TO-PMOD-11	—	15.68/17.10
LMZ23608/10	8/10	6 to 36	0.8 to 6	94	EN, SS, Freq Sync, Current Share	350 to 600	3000	32	Yes		TO-PMOD-11	—	16.50/18.00

*Suggested resale price in U.S. dollars in quantities of 1,000.

New devices are listed in bold red.

Battery Management Products Overview

TI's battery management products, tools and expertise make it easier for engineers to design more efficient, longer lasting and more reliable battery-powered applications. TI brings cutting-edge solutions for new battery chemistries and technologies in automotive, industrial and personal-electronics applications. Innovations include faster and cooler battery chargers, automotive monitoring and protection ICs with advanced precision and integration that provides accurate and reliable gauges.

Battery Management Fundamentals

In addition to battery-management experts, easy-to-use tools and training, TI offers evaluation boards, reference designs and educational videos for a streamlined development cycle that lets you get your products to market faster.

For more information, visit www.ti.com/battery

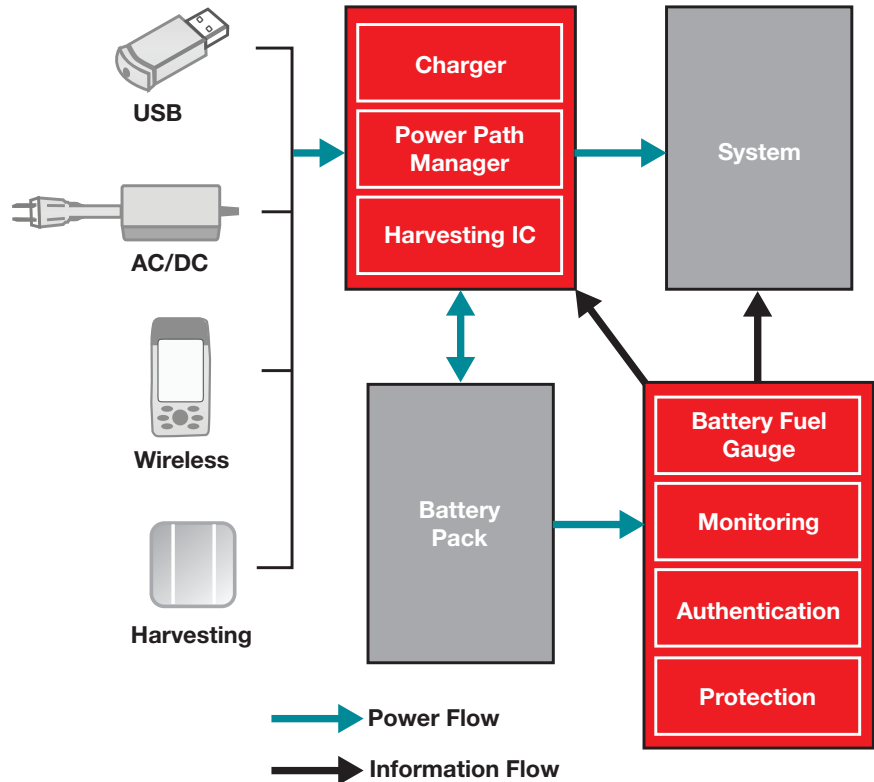

Battery Charger ICs

Device	Number of Cells	V _{IN} Absolute Max (V)	V _{IN} OVP (V)	Charge Current (A)	Charge Voltage (V)	Control Interface	Topology	Integrated Power FET	Temperature Monitor	Packaging		EVM	Comments	Automotive Grade	Price*
										WCSP	QFN/MLP				
Multi-Chemistry (Li-Ion and NiCd/NiMH)															
bq25120A	1	20	5.5	0.30	3.6 to 4.65	I ² C/Stand Alone	Linear	Yes	Yes	25		✓	Integrated battery management unit, with buck converter, LDO, pushbutton controller, battery voltage monitor, JEITA, power path, 700-nA low I _q		1.60
bq24030/31/35	1	18	6.4	2	4.2/4.1/4.2	Stand Alone	Linear	Yes	Yes	20		✓	Dual input, regulated 4.4-V output for AC input condition, power path	✓	1.80
bq24032A/38	1	18	6.4	2	4.2/ (4.24/4.36)	Stand Alone	Linear	Yes	Yes	20		✓	Dual Input, regulated 4.4-V output for AC input condition, power path		1.80
bq24040/41	1	30	6.6/7.1	1	4.2	Stand Alone	Linear	Yes	Yes	10		✓			0.45
bq24045	1	30	6.6/7.1	1	4.35	Stand Alone	Linear	Yes	Yes	10		✓			0.45
bq24050/52	1	30	6.6	0.8	4.2	Stand Alone	Linear	Yes	Yes	10		✓	JEITA charging (100K NTC — bq24052)		0.50
bq24072/72T	1	28	6.6	1.5	4.3 / 4.2	Stand Alone	Linear	Yes	Yes	16		✓	V _{OUT} tracks V _{BAT} , V _{IN} _DPPM, power path		1.00
bq24073	1	28	6.6	1.5	4.2	Stand Alone	Linear	Yes	Yes	16		✓	V _{IN} _DPPM, power path		1.00
bq24074	1	28	10.5	1.5	4.2	Stand Alone	Linear	Yes	Yes	16		✓	V _{IN} _DPPM, power path		1.00
bq24075T/79T	1	28	6.6	1.5	4.2/4.1	Stand Alone	Linear	Yes	Yes	16		✓	SYSOFF pin disconnects battery, V _{IN} _DPPM, powers system and charges battery, Power path	✓	1.00
bq24090/91	1	12	6.6	1	4.2	Stand Alone	Linear	Yes	Yes	10		✓	10K NTC (100K NTC — bq24091)		0.40
bq24092/93	1	12	6.6	1	4.2	Stand Alone	Linear	Yes	Yes	10		✓	JEITA, 10K NTC (JEITA, 100K NTC — bq24093)		0.40
bq24095	1	12	6.6	1	4.35	Stand Alone	Linear	Yes	Yes	10		✓	10K NTC		0.40
bq24157	1	20	6.5	1.25	3.5 to 4.4	I ² C	Switching	Yes	No	20		✓	USB OTG supported with boost, no battery detect on power up, safety timer disabled		0.50
bq24158	1	20	6.5	1.25	3.5 to 4.4	I ² C	Switching	Yes	No	20		✓	USB OTG supported with boost, no battery detect on power up (bq24158)		0.50
bq24160/A	1	20	10.5/6.5(USB)	2.5/1.5	3.5 to 4.4	I ² C	Switching	Yes	Yes	49	24	✓	Dual input, D+/D- detect, JEITA, 3-V V _{BAT} _SHORT, power path		1.95

*Suggested resale price in U.S. dollars in quantities of 1,000.

Battery Management Products

Selection Guide

Battery Charger ICs (Continued)

Device	Number of Cells	VIN Absolute Max (V)	VIN OVP (V)	Charge Current (A)	Charge Voltage (V)	Control Interface	Topology	Integrated Power FET	Temperature Monitor	Packaging		EVM	Comments	Automotive Grade	Price*
										WCSP	QFN/MLP				
Multi-Chemistry (Li-Ion and NiCd/NiMH) (Continued)															
bq24161/B	1	20	10.5/6.5(USB)	2.5/1.5	3.5 to 4.4	I ² C	Switching	Yes	Yes	49		✓	Dual input, USB selection pin, std temp, power path		1.95
bq24163	1	20	10.5/6.5(USB)	2.5/1.5	3.5 to 4.4	I ² C	Switching	Yes	No	49	24	✓	Dual input, D+/D- detect, JEITA, Power path		1.95
bq24165	1	20	10.5/6.5(USB)	2.5/1.5	4.2	Stand Alone	Switching	Yes	No	49		✓	Dual input, IUSB1/2/3 USB select, no temp monitor, JEITA, power path		1.95
bq24166	1	20	10.5/6.5(USB)	2.5/1.5	4.2	Stand Alone	Switching	Yes	Yes	49		✓	Dual input, IUSB1/2/3 USB select, temp monitor, std temp, power path		1.95
bq24190	1	20	18	4.5	3.5 to 4.4	I ² C/Stand Alone	Switching	Yes	Yes		24	✓	D+/D-, 1.3-A OTG, standard temp., 12-mW battery FET		1.50
bq24192	1	20	18	4.5	3.5 to 4.4	I ² C/Stand Alone	Switching	Yes	Yes		24	✓	PSEL, 1.3-A OTG, standard temp., 12-mW battery FET		1.50
bq24192I	1	20	18	4.5	3.5 to 4.4	I ² C/Stand Alone	Switching	Yes	Yes		24	✓	PSEL, 1.3-A OTG, standard temp., 4.1-V and 1.5-A default charging		1.50
bq24193	1	20	18	4.5	3.5 to 4.4	I ² C/Stand Alone	Switching	Yes	Yes		24	✓	PSEL, 1.3-A OTG, JEITA, 12-mW battery FET		1.50
bq24196	1	20	18	2.5	3.5 to 4.4	I ² C/Stand Alone	Switching	Yes	Yes		24	✓	PSEL, 1.3-A OTG, standard temp., 12-mW battery FET		1.25
bq24195L	1	20	18	2.5	3.5 to 4.4	I ² C/Stand Alone	Switching	Yes	Yes		24	✓	D+/D-, 5.1-V, 1.0-A synchronous boost for power bank		1.15
bq24195	1	20	18	4.5	3.5 to 4.4	I ² C/Stand Alone	Switching	Yes	Yes		24	✓	D+/D-, 5.1-V, 2.1-A synchronous boost for power bank		1.25
bq24232	1	28	10.5	0.5	4.2	Stand Alone	Linear	Yes	Yes		16	✓	SYSOFF pin disconnects battery, VIN_DPPM, powers system and charges battery, power path		1.00
bq24232H	1	28	10.5	0.5	4.35	Stand Alone	Linear	Yes	Yes		16	✓	Higher voltage battery pack flexibility (4.35 V), USB friendly, powers system and charges battery, power path		1.15
bq24250	1	20	10.5	2.0	3.5 to 4.4	I ² C/Stand Alone	Switching	Yes	Yes	30	24	✓	EN1-2 for detection, JEITA, power path		1.25
bq24253	1	20	10.5	2.0	4.2	Stand Alone	Switching	Yes	Yes	30	24	✓	D+/D- detection, JEITA, power path		1.25
bq24295	1	16	6.4	3	3.5 to 4.4	I ² C/Stand Alone	Switching	Yes	Yes		24	✓	D+/D-, USB and non-standard port detection, 1.5-A, 4.5-V-5.5 V adjustable OTG voltage for power bank		0.80
bq24296	1	16	6.4	3	3.5 to 4.4	I ² C/Stand Alone	Switching	Yes	Yes		24	✓	PSEL, Compatible to BC1.2, standard temp., shipping mode		0.90
bq24297	1	16	6.4	3	3.5 to 4.4	I ² C/Stand Alone	Switching	Yes	Yes		24	✓	D+/D-, USB and non-standard port detection, 1.5-A, 4.5-V-5.5 V adjustable OTG voltage		0.90
bq25040	1	30	6.9	1.1	4.2	Stand Alone	Linear	Yes	Yes		10	✓	USB compliant w/50-mA integrated LDO		0.55
bq25050	1	30	6.5	1	4.2	Single Wire	Linear	Yes	Yes		10	✓	Single-wire interface, power path		0.60
bq25060	1	30	10.5	1	4.2	Stand Alone	Linear	Yes	Yes		10	✓	USB compliant w/50-mA integrated LDO, power path		0.65
bq25100	1	30	6.6	0.25	4.2	Stand Alone	Linear	Yes	Yes	6		✓	Small linear charger with programmable termination down to 1-mA and 75-nA battery leakage. 4.2-V battery		0.75
bq25100A	1	30	6.6	0.25	4.3	Stand Alone	Linear	Yes	Yes	6		✓	Small linear charger with programmable termination down to 1-mA and 75-nA battery leakage. 4.3-V battery		0.75
bq25100H	1	30	6.6	0.25	4.35	Stand Alone	Linear	Yes	Yes	6		✓	Small linear charger with programmable termination down to 1-mA and 75-nA battery leakage. 4.35-V battery		0.75
bq25101	1	30	6.6	0.25	4.2	Stand Alone	Linear	Yes	Yes	6		✓	Small linear charger with /CHG pin, 1-mA termination support and 75-nA battery leakage. 4.2-V battery		0.75
bq24130	1 to 3	20	Adj	4	Adj	Stand Alone	Switching	Yes	Yes		20	✓	Supports Li-Ion and Super Cap		1.95
bq24133	1 to 3	20	Adj	2.5	4.2/Cell	Stand Alone	Switching	Yes	Yes		24	✓	Power Path		1.20
bq24170	1 to 3	20	Adj	4	4.2/Cell	Stand Alone	Switching	Yes	Yes		24	✓	Power Path		1.70
bq24171	1 to 3	20	Adj	4	Adj	Stand Alone	Switching	Yes	Yes		24	✓	JEITA, Power Path		1.70
bq24172	1 to 3	20	Adj	4	Adj	Stand Alone	Switching	Yes	Yes		24	✓	Adjustable charge voltage, power path		1.70
bq24707A	1 to 4	30	Adj	8	Adj	SMBus	Switching	No	No		20	✓	Programmable switching frequency		2.90
bq24735	1 to 4	30	Adj	8	Adj	SMBus	Switching	No	No		20	✓	Intel™ CPU Turbo Mode support		3.00
bq24617	1 to 5	33	32	10 (Ext)	Adj	Stand Alone	Switching	No	Yes		24	✓	600 kHz		2.40
bq24600	1 to 6	33	32	10 (Ext)	Adj	Stand Alone	Switching	No	Yes		16	✓	1200 kHz		2.40
bq24610	1 to 6	33	32	10 (Ext)	Adj	Stand Alone	Switching	No	Yes		24	✓	600 kHz		2.40
bq24616	1 to 6	33	32	10 (Ext)	Adj	Stand Alone	Switching	No	Yes		24	✓	JEITA		2.40
bq24618	1 to 6	33	32	10 (Ext)	Adj	Stand Alone	Switching	No	Yes		24	✓	USB VIN and adapter		2.40
bq24715	2 to 3	30	26	8	Adj	SMBus	Switching	No	No		20	✓	NVDC charger		1.60
bq24725A	1 to 4	30	Adj	8	Adj	SMBus	Switching	No	No		20	✓	Programmable switching frequency, enhanced safety, battery learn		1.70
bq24770	1 to 4	30	26	8	Adj	SMBus	Switching	No	No		28	✓	NVDC charger		1.50
bq24773	1 to 4	30	26	8	Adj	I ² C	Switching	No	No		28	✓	NVDC charger		1.50
bq24780S	1 to 4	30	26	8	Adj	SMBus	Switching	No	No		28	✓	Intel™ CPU Turbo Mode support		1.20
bq25703A	1 to 4	30	26	8	Adj	I ² C	Switching	No	No		32	✓	Buck-boost NVDC charger with wide range of input sources. Power/current monitoring		2.20

*Suggested resale price in U.S. dollars in quantities of 1,000.

Battery Management Products

Selection Guide

Battery Charger ICs (Continued)

Device	Number of Cells	V _{IN} Absolute Max (V)	V _{IN} OVP (V)	Charge Current (A)	Charge Voltage (V)	Control Interface	Topology	Integrated Power FET	Temperature Monitor	Packaging			EVM	Comments	Automotive Grade	Price*
										WCS	QFN/MLP	DIP				
Multi-Chemistry (Li-Ion and NiCd/NiMH) (Continued)																
bq25890	1	22	14	5	3.8 to 4.6	i ² C/Stand Alone	Switching	Yes	Yes		24	✓	MaxCharge™ Technology, D+/D-, 2.4-A OTG, JEITA, 11-mW battery FET		1.50	
bq25892	1	22	14	5	3.8 to 4.6	i ² C/Stand Alone	Switching	Yes	Yes		24	✓	MaxCharge Technology, PSEL, 2.4-A OTG, JEITA, 11-mW battery FET		1.50	
bq25896	1	22	14	3	3.8 to 4.6	i ² C/Stand Alone	Switching	Yes	Yes		24	✓	MaxCharge Technology, PSEL, 2.0-A OTG, JEITA, 11-mW battery FET		1.50	
bq25895	1	22	14	5	3.8 to 4.6	i ² C/Stand Alone	Switching	Yes	Yes		24	✓	MaxCharge Technology, D+/D-, 3.1-A OTG, JEITA, 11-mW battery FET		1.40	
bq25898	1	22	14	4	3.8 to 4.6	i ² C/Stand Alone	Switching	Yes	Yes	42		✓	MaxCharge Technology, PSEL, 2.4-A OTG, JEITA, 5-mW battery FET. WCS		1.40	
bq25898C	1	22	14	3	3.8 to 4.6	i ² C	Switching	Yes	No	42		✓	3-A Slave Charger, WCS		1.40	
bq25898D	1	22	14	4	3.8 to 4.6	i ² C/Stand Alone	Switching	Yes	Yes	42		✓	MaxCharge Technology, D+/D-, 2.4-A OTG, JEITA, 5-mW battery FET, WCS		1.40	
bq25600	1	22	13.5	3	3.85 to 4.62	i ² C	Switching	Yes	Yes	30		✓	Wide Vin, Power Path, DPM, PSEL, 1.2-A OTG, JEITA, 19.5-mΩ battery FET		1.30	
bq25600C	1	22	13.5	3	3.85 to 4.62	i ² C	Switching	Yes	No	30		✓	Wide Vin, Power Path, DPM, 19.5-mΩ battery FET		1.20	
bq25600D	1	22	13.5	3	3.85 to 4.62	i ² C	Switching	Yes	Yes	30		✓	Wide Vin, Power Path, DPM, D+/D-, 1.2-A OTG, JEITA, 19.5-mΩ battery FET		1.30	
bq25601	1	20	13.5	3	3.85 to 4.62	i ² C	Switching	Yes	Yes		24	✓	Wide Vin, Power Path, DPM, PSEL, 1.2-A OTG, JEITA, 19.5-mΩ battery FET, P2P bq24296		1.25	
bq25606	1	20	13.5	3	4.2/4.4	Stand Alone	Switching	Yes	Yes		24	✓	Wide Vin, Power Path, DPM, PSEL, 1.2-A OTG, JEITA, 19.5-mΩ battery FET, standalone		1.15	
bq25910	1	20	14	6	3.5 to 4.78	i ² C	Switching	Yes	Yes	36		✓	Three-level switch-mode parallel charger, superior efficiency 95.4% at 1 A with 5 Vin, 93.3% at 3 A with 9 Vin		2.10	
Inductorless Flash Charger ICs																
bq25871	1	22	7	7	4.2 to 4.98	i ² C	Switching	Yes	Yes	42		✓	Flash charger, 13-mΩ FETs, extensive programmable safety protection		1.30	
bq25872	1	40	14	7	4.2 to 4.98	i ² C	Switching	Yes	Yes	42		✓	Flash charger, 13-mΩ FETs, extensive programmable safety protection		1.30	
bq25970	1	40	12.35	8	3.5 to 4.65	i ² C	Switching	Yes	Yes	56		✓	Three-level switched cap charger, output current is 2x of input current		2.50	
LiFePO₄																
bq25070	1	30	10.5	1	3.5	Stand Alone	Linear	Yes	Yes	10		✓	LiFePO ₄ , 50-mA LDO		0.75	
bq25071	1	30	10.5	1	3.5	Stand Alone	Linear	Yes	Yes	10		✓	LiFePO ₄ , 50-mA LDO		0.75	
bq24620	1 to 7	33	32	10 (Ext)	Adj	Stand Alone	Switching	No	Yes	16		✓	LiFePO ₄ , 300 kHz		2.00	
bq24630	1 to 7	33	32	10 (Ext)	Adj	Stand Alone	Switching	No	Yes	24		✓	LiFePO ₄ , 300 kHz, power selector		2.00	
Super Cap																
bq24640	1 to 9	33	32	10 (Ext)	Adj	Stand Alone	Switching	No	Yes	16		✓	SuperCap		2.00	
NiCd/NiMH Chemistry																
bq2002/C/E/F	Multiple	7	—	>2	6	Stand Alone	Current-limited	No	Yes		8	8		Trickle charge		0.85
bq2004/E/H	Multiple	7	—	>2	5.5	Stand Alone	Switching	No	Yes		16	16		Selectable timers and pulse-trickle rates		2.15
bq2005	Multiple	7	—	>2	5.5	Stand Alone	Switching	No	Yes		20	20		Sequential fast charge of two battery packs		2.15
bq24400/1	Multiple	7	—	>2	5.5	Stand Alone	Switching	No	Yes		8	8				1.55
Lead-Acid Chemistry																
bq24450	Multiple	40	—	>2	—	Stand Alone	Linear	No	No		16	16		Temp-compensated internal reference		2.75
bq2031	Multiple	7	—	>2	—	Stand Alone	Switching	No	Yes		16	16	✓	Three user-selectable charge algorithms to accommodate cyclic and standby applications		2.80

*Suggested resale price in U.S. dollars in quantities of 1,000.

Battery Management Products

Selection Guide

Battery Charger ICs (Continued)

Device	Number of Cells	V _{IN} Absolute Max (V)	V _{IN} OVP (V)	Charge Current (A)	Charge Voltage (V)	Control Interface	Topology	Integrated Power FET	Temperature Monitor	Packaging				EVM	Comments	Price*
										QFN/MLP	TSSOP	SOIC	DIP			
Multi-Chemistry (Li-Ion and NiCd/NiMH)																
bq2000/T	Multiple	7	—	—	—	Stand Alone	Switching	Yes	Yes		8	8	8	✓	Charges NiCd, NiMH, and Li-Ion	1.45
bq24650	1 to 6	33	32	10 A (Ext)	Adj	Stand Alone	Switching	No	Yes	16				✓	Max power point tracking	2.00
bq24765	2 to 4	30	—	—	—	Stand Alone	Switching	Yes	No	34				✓	SMBus charger with integrated power FETs	3.00

*Suggested resale price in U.S. dollars in quantities of 1,000.

Energy Harvesting & Solar Charging

Device	Number of Cells	V _{IN} Absolute Max (V)	V _{IN} OVP (V)	Charge Current (A)	Charge Voltage (V)	Control Interface	Topology	Integrated Power FET	Temperature Monitor	Packaging				EVM	Comments	Price*
										QFN/MLP	TSSOP	SOIC	DIP			
Solar/Energy Harvesting (Li-Ion)																
bq24210	1	20	7.7	0.800	4.2	Stand Alone	Linear	Yes	Yes	10				✓	Solar panel V _{IN}	1.10
bq25504	1	5.5	Adj	0.1	2.5 to 5.25	Stand Alone	Boost	Yes	Yes	16				✓	Energy harvester, ultra-low power and quiescent current, high efficiency, dynamic MPPT	2.05
bq25505	1	5.5	Adj	0.1	2.5 to 5.25	Stand Alone	Boost	Yes	Yes	16				✓	Energy harvester, 330-nA ultra-low power and quiescent current, high efficiency, dynamic MPPT, autonomous power-path multiplexing	2.25
bq25570	1	5.5	Adj	0.1	2.5 to 5.25	Stand Alone	Boost-Buck	Yes	Yes	16				✓	Energy harvester, <488-nA ultra-low power and quiescent current, high efficiency, dynamic MPPT	3.20
bq24650	1 to 6	33	32	10 (Ext)	Adj	Stand Alone	Switching	No	Yes	16				✓	Max power point tracking	2.00
bq25895	1	22	14	5	3.8 to 4.6	I ² C/Stand Alone	Switching	Yes	Yes	24				✓	MPPT Reference Design TIDA-01556 on ti.com, integrated ADC, D+/-D-, JEITA, 11-mW battery FET	1.40

*Suggested resale price in U.S. dollars in quantities of 1,000.

Single-Cell Fuel Gauges

Device	Min Max Series Cell	SHA-1 Authentication	System or Pack	Communication Protocol	Other Features	Package	Price*
Lithium-Ion, Lithium-Polymer Chemistry							
bq27220	1	—	System / Pack	I ² C	ROM based pack/system side CEDV gauge, 3 preprogrammed selectable profiles + space for custom profiles, low power consumption	9-pin CSP	0.93
bq27621	1	-	System/ Pack	I ² C	DVC fuel gauge with no sense resistor, low power consumption	9-pin CSP	0.85
bq27421	1	—	System	I ² C	ROM based Impedance Track™ fuel gauge with preprogrammed profile and integrated sense resistor	9-pin CSP	1.05
bq27426	1	—	System	I ² C	ROM based System-side fuel gauge with Impedance Track technology, 3 pre-programmed profiles, low power consumption	9-pin CSP	0.99
bq27411	1	—	Pack	I ² C	ROM based pack side Impedance Track fuel gauge with preprogrammed profile	12-pin QFN	1.15
bq27441	1	—	System	I ² C	ROM based system side Impedance Track fuel gauge with preprogrammed profile	12-pin QFN	1.15
bq27320	1	—	System / Pack	I ² C	Flash based pack/system side fuel gauge with CEDV technology	15-pin CSP	1.18
bq27520	1	—	System	I ² C	System Side Impedance Track fuel gauge	15-pin CSP	1.20
bq27546-G1	1	Yes	Pack	I ² C/HDQ	Flash based pack-side fuel gauge with Impedance Track technology	12-pin CSP	1.20
bq27542-G1	1	Yes	Pack	I ² C/HDQ	Flash based pack-side fuel gauge with Impedance Track technology	15-pin CSP	1.25
bq2753x	1	—	System	I ² C	Flash based Impedance Track technology fuel gauge with charger control	15-pin CSP	1.30
bq27742-G1	1	Yes	Pack	I ² C/HDQ	Flash based Impedance Track fuel gauge with integrated protector	15-pin CSP	1.35
bq27750	1	Yes	Pack	I ² C/HDQ	Flash based Impedance Track fuel gauge with integrated AFE and support 1mOhm sense resistor	12-pin QFN	1.45

*Suggested resale price in U.S. dollars in quantities of 1,000.

Battery Management Products

Selection Guide

Multi-Cell Fuel Gauges

Device	Approx. Battery Capacity (mAh)	Min Max Series Cell	Number of LEDs	Communication Protocol	Other Features	Package	Price*
Lithium-Ion, Lithium-Polymer, LiFePO₄ Chemistry							
bq28z610	100 to 14000	1 to 2	—	I ² C	1-2 series Impedance Track™ fuel gauge	12-pin SON	1.65
bq78z100	100 to 14000	1 to 2	—	HDQ	1-2 series Impedance Track fuel gauge	12-pin SON	1.90
bq34z100-G1	Up to 650 Ah	1 to 16	4	I ² C or HDQ	Wide-range fuel gauge with Impedance Track technology	14-pin TSSOP	1.90
bq78350-R1	100 to 320000	3 to 15	5	SMBus	CEDV Li-Ion gas gauge & battery management companion controller	32-pin QFN	2.01
bq4050	100 to 29000	1 to 4	5	SMBus	1-4 series CEDV Li-Ion battery pack manager, battery fuel (gas) gauge	32-pin QFN	2.20
bq40z50-R2	100 to 29000	1 to 4	5	SMBus	1-4 series Impedance Track Li-Ion battery pack manager, battery fuel (gas) gauge	32-pin QFN	2.70
bq20z655-R1	800 to 32000	2 to 4	3, 4, 5 or LCD	SMBus	Impedance Track fuel gauge with LCD integrated protector	44-pin TSSOP	5.20
Lead Acid Chemistry							
bq34z100-G1	Up to 29000	1 to 16	4	I ² C or HDQ	Wide-range fuel gauge with Impedance Track technology	14-pin TSSOP	1.90
bq34110	Up to 32000	1 to 16	—	I ² C or HDQ	Multi-Chemistry High-cell Count Battery Fuel Gauge w/Integrated Rarely Discharged Module	14-pin TSSOP	1.90
Super Cap							
bq33100	—	2 to 5	—	SMBus	Fully integrated 2, 3, 4 and 5 series super capacitor manager	24-pin TSSOP	4.20

*Suggested resale price in U.S. dollars in quantities of 1,000.

Battery Monitors

Device	Number of Cells	Stackable	Communication Protocol	Protection Features	Description	Package	Automotive Grade	Price*
bq76920	3 to 5	No	I ² C	V, I, T	Battery Monitor with digital I ² C interface, integrated ADCs and hardware protection	20-pin TSSOP		1.50
bq76930	6 to 10	No	I ² C	V, I, T	Battery Monitor with digital I ² C interface, integrated ADCs and hardware protection	30-pin TSSOP		2.75
bq76940	9 to 15	No	I ² C	V, I, T	Battery Monitor with digital I ² C interface, integrated ADCs and hardware protection	44-pin TSSOP		3.95
bq76925	3 to 6	No	I ² C	V, I, T	Host-controlled monitor with cell balancing and integrated short circuit fault	20TSSOP/24VQFN		0.99
bq76PL536A	3 to 6	Up to 192	SPI	V, T	3- to 6-Cell ESS and UPS stackable monitor and cell-balancing AFE	64-pin HTQFP		3.98
bq76PL536A-Q1	3 to 6	Up to 192	SPI	V, T	3- to 6-Cell automotive-qualified EV and UPS stackable monitor and cell-balancing AFE	64-pin HTQFP	✓	4.69
bq76PL455A-Q1	6 to 16	Up to 256	UART	V, T	16-Cell EV/HEV Integrated Battery Monitor and Protector - Highly accurate monitoring, integrated protection	80-pin TQFP	✓	10.00
bq77PL900	5 to 10	No	I ² C	V, I, T	Dual-mode analog front-end standalone voltage, current and temperature pack protector	48-pin SSOP		2.95
bq79606-Q1	3 to 6	Up to 300	UART	V, T	6-Cell SafeTI™ precision monitor with integrated hardware protector for automotive battery packs	48-pin PQFP	✓	7.99
bq76PL455A	6 to 16	Up to 256	UART	V, T	16-Cell ESS/UPS integrated battery monitor and protector - Highly accurate monitoring, integrated protection	80-pin TQFP		9.49

*Suggested resale price in U.S. dollars in quantities of 1,000.

Peripherals

Device	Description	Package	Automotive Grade	Price*
bq76200	High-Side N-Channel FET Driver	16-pin TSSOP		1.00
EMB1428Q	Switch Matrix Gate Driver used for Active Cell Balancing	48-pin WQFN	✓	3.63
EMB1499Q	Bidirectional Current DC/DC Controller used for Active Cell Balancing	28-pin HTSSOP	✓	2.00

Suggested resale price in U.S. dollars in quantities of 1,000.

Battery Management Products

Selection Guide

Battery Charger Protection

Device	V _{IN} Max (V)	OVP (V)	OCF	Battery OVP (V)	LDO Output (V)	Max Operating Current (µA)	Package(s)	EVM	Comments	Price*
bq24300/5	30	10.5	Fixed 300 mA	4.35	5.5/5.0	400/500/500	8-QFN/SON	✓	Reverse polarity protection	0.30
bq24308	30	6.3	Fixed 700 mA or Prog. <1.5 A	4.35	5	500	8-QFN/SON	✓	Reverse polarity protection	0.30
bq24311	30	5.85	30 mA to 500 mA	5.85	—	500	8-QFN/SON	✓	Fault indication	0.35
bq24312	30	5.85	Prog. <1.5 A	4.35	—	500	8/12-QFN/SON		Fault indication	0.35
bq24313	30	10.5	Prog. <1.5 A	4.35	—	500	8/12-QFN/SON		Fault indication	0.35
bq24314/A	30	5.85	Prog. <1.5 A	4.35	—	600	8/12-QFN/SON	✓	Fault indication	0.35
bq24314C	30	5.85	Prog. <1.5 A	4.45	—	600	8/12-QFN/SON	✓	Fault indication	0.35
bq24315	30	5.85	Prog. <1.5 A	4.35	5.5	600	8-QFN/SON	✓	Fault indication	0.35
bq24316	30	6.8	Prog. <1.5 A	4.35	—	600	8/12-QFN/SON	✓	Fault indication	0.35
bq24380	30	6.3	No OCP	4.35	5.5	250	8-QFN/SON	✓	Fault indication	0.25
bq24381	30	7.1	No OCP	4.35	5	300	8-QFN/SON	✓	Fault indication	0.25
bq24382	30	10.5	No OCP	4.35	5	300	8-QFN/SON		Fault indication	0.25
bq24350	30	6.17	Fixed 1.2 A	4.35	5.5	500	8-QFN/SON	✓	Integrated charge FET	0.40
bq24351	30	10.5	Fixed 1.2 A	4.35	6.38	500	8-QFN/SON	✓	Integrated charge FET	0.40
bq24352	30	7.1	Fixed 1.2 A	4.35	5.5	500	8-QFN/SON	✓	Integrated charge FET	0.40

*Suggested resale price in U.S. dollars in quantities of 1,000.

Battery (Li-Ion) Protection

Device	Number of Series Cells	Overvoltage Range (V)	Protection Features	Description	Package(s)	Automotive Grade	Price*
bq297xy	1	3.85 to 4.60 (50-mV steps)	V, I, T	Li-Ion/Li Polymer Advanced Single-Cell Battery Protector IC Family	6-pin SON		0.20
bq2980	1	3.75 to 5.20 (50-mV steps)	V, I, T	Advanced Single-Cell Battery Protector IC with High side NFET driving ideal for fast charging applications	8-pin RUG		0.50
bq29200	2	4.35	V	Overvoltage safety with cell balancing	8-pin SON		0.30
bq29209	2	4.3	V	Overvoltage safety with cell balancing	8-pin SON		0.30
bq29209-Q1	2	4.3	V	Overvoltage safety with cell balancing for eCall	8-pin SON	✓	0.35
bq2945xy	2 or 3	3.850 to 4.60	V	Overvoltage safety for chemical fuse activation	6-pin SON		0.25
bq2947xy	2 to 4	3.850 to 4.60	V	Overvoltage safety for chemical fuse activation	8-pin SON		0.28
bq2961xy	2 to 4	3.850 to 4.60 (50-mV steps)	V	Overvoltage safety for chemical fuse activation with LDO	8-pin SON		0.30
bq2946xy	1	3.850 to 4.60	V	Overvoltage safety for chemical fuse activation	6-pin SON		0.16
bq7716xy	2 to 4	3.85 to 4.65	V	Overvoltage protection with external delay capacitor	8-pin QFN		0.51
bq7718xy	2 to 5	3.85 to 4.65	V	Overvoltage protection with internal delay timer	8-pin QFN		0.69

*Suggested resale price in U.S. dollars in quantities of 1,000.

Authentication and Identification

Device	Interface	Pins	Security	Temp (°C)	Package	Price*
bq2022A	SDQ™	3	ID number	-40 to 85	3 SOT-23, 3 TO-92	0.90
bq2024	SDQ	3	ID number	-40 to 85	3 SOT-23	0.95
bq2026	SDQ	3	CRC	-20 to 70	3 SOT-23, 3 TO-92	0.90
bq2028	HDQ	12	ID number	-40 to 85	12 DSBGA	1.10
bq26100	SDQ	6	SHA-1 Authentication	-40 to 85	6 VSON	0.95

*Suggested resale price in U.S. dollars in quantities of 1,000.

Power MOSFETs Overview

TI's premier power management innovation called NexFET™ technology combines vertical current flow with a lateral power MOSFET. It provides a low on resistance and requires an extremely low gate charge with industry-standard package outlines—a combination not previously possible with existing silicon platforms.

NexFET technology delivers high performance for both N- and P-channel power MOSFET devices. Designers are able to achieve 90% power supply efficiencies from light to full loads with high output currents and low duty cycles, representing a breakthrough in discrete designs.

	NexFET™ Technology	Industry Standard
Control FET	$R_{DS(on)} = 5.8 \text{ m}\Omega$	$R_{DS(on)} = 6.6 \text{ m}\Omega$
	$Q_G = 6.5 \text{ nC}$	$Q_G = 12.3 \text{ nC}$
Sync FET	$R_{DS(on)} = 2.5 \text{ m}\Omega$	$R_{DS(on)} = 2.3 \text{ m}\Omega$
	$Q_G = 13.2 \text{ nC}$	$Q_G = 39.8 \text{ nC}$

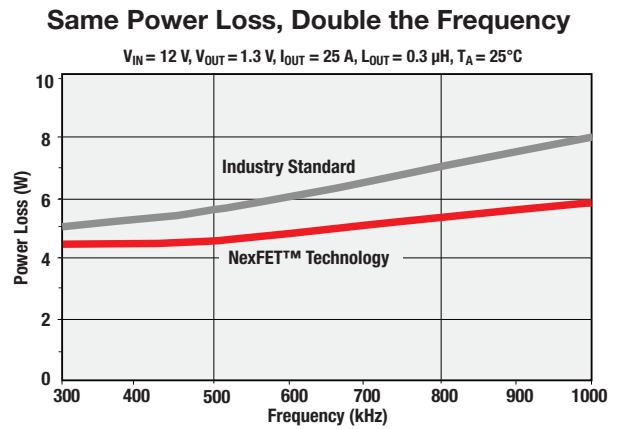
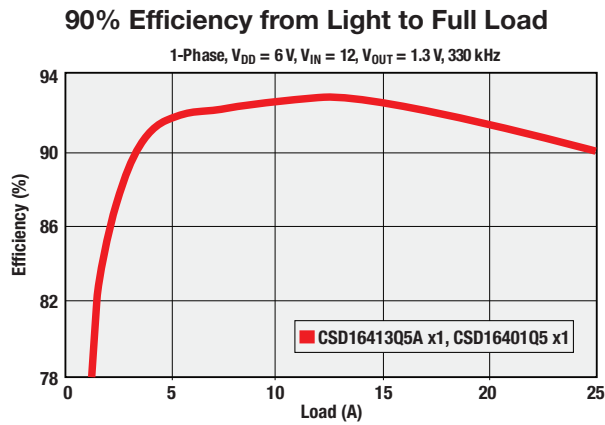

System Block Diagram of TI Electronics in a Power System Design

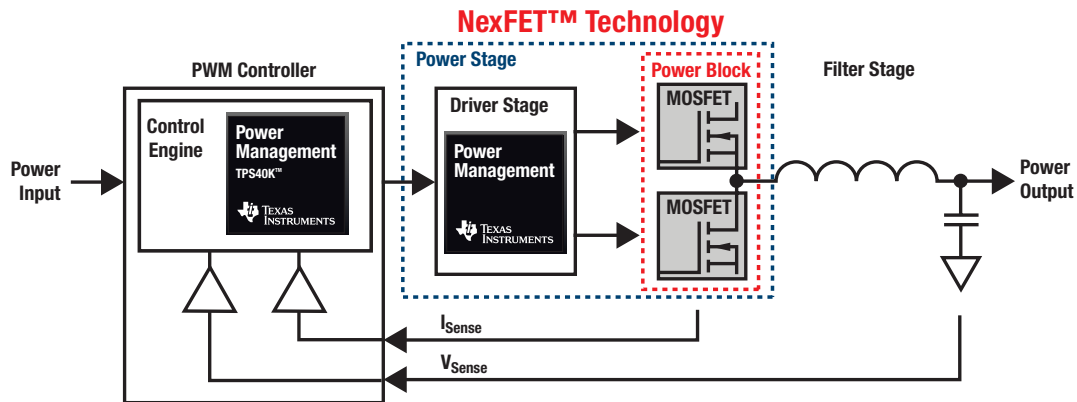

Power MOSFETs

Selection Guide

N-Channel MOSFET Transistors

Device	V _{DS} (V)	V _{GS} (V)	Typical V _{GS(th)} (V)	Maximum R _{DS(on)} (mΩ)		I _D , Package Limited (A)	I _D , Silicon Limited at T _C = 25°C (A)	I _{DM} (max), Pulsed Drain Current (A)	Typical Q _G (nC)	Typical Q _{GD} (nC)	Price*
				at 10 V	at 4.5 V						
LGA 0.64x73 (CSP)											
Single											
CSD15380F3	20	10	1.1	—	1460	—	—	1.6	0.216	0.027	0.05
CSD13380F3	12	8	0.85	—	76	—	—	13.5	0.91	0.15	0.05
LGA 0.6x1 (CSP)											
Single											
CSD17381F4	30	12	0.85	109	117	—	—	10	1.04	0.133	0.06
CSD17382F4	30	10	0.9	—	67	—	—	14.8	2.1	0.63	0.06
CSD17483F4	30	12	0.85	230	260	—	—	5	1.01	0.13	0.04
CSD17484F4	30	12	0.85	—	128	—	—	18	0.92	0.075	0.07
CSD13381F4	12	8	0.85	—	180	—	—	7	1.06	0.14	0.04
CSD13383F4	12	10	1	—	44	—	—	27	2	0.6	0.07
LGA 0.77x1.53 (CSP)											
Single											
CSD18541F5	60	20	1.75	65	75	—	—	21	11	1.6	0.11
CSD17585F5	30	20	1.3	27	33	—	—	34	1.9	0.39	0.10
CSD13385F5	12	8	0.8	—	19	—	—	41	3.9	0.39	0.10
WLP 1x1 (CSP)											
Single											
CSD13302W	12	10	1	—	17.1	—	—	29	6	2.1	0.09
WLP 1x1.5 (CSP)											
Single											
CSD13306W	12	10	1	—	10.2	—	—	44	8.6	3	0.14
WLP 1.7x2.3 (CSP)											
Dual-FET Common Source											
CSD86311W1723	25	10	1	—	42	—	4.5	4.5	3.1	0.33	0.37
WLP 2.2x1.15 (CSP)											
Dual-FET Common-Drain LGA											
CSD83325L	12	10	0.95	—	5.9	—	—	52	8.4	1.9	0.19
WLP 1.35x1.35 (CSP)											
Dual-FET Common-Drain LGA											
CSD85302L	20	10	0.9	—	24	—	—	37	6	1.4	0.16
WLP 3.4x1.5 (CSP)											
Dual-FET Common-Drain LGA											
CSD87501L	30	20	1.8	3.9	5.5	—	—	72	15	6	0.31
SO-8 Dual											
CSD88537ND	60	20	3	15	—	—	16	62	14	2.3	0.45
CSD88539ND	60	20	3	28	—	15	11.7	46	14	2.3	0.30
SON 2x2 (QFN)											
Dual Independent											
CSD85301Q2	20	10	0.9	—	27	5	—	26	4.2	1	0.16
CSD87502Q2	30	20	1.6	32.4	42	5	—	23	2.2	0.5	0.17
Single											
CSD17318Q2	30	10	0.9	—	16.9	22	25	68	6	1.3	0.13
CSD13202Q2	12	8	0.8	—	9.3	22	—	76	5.1	0.76	0.14
CSD15571Q2	20	20	1.45	15	19.2	22	—	52	2.5	0.66	0.11
CSD17571Q2	30	20	1.6	24	29	22	—	39	2.4	0.6	0.13
CSD16301Q2	25	10	1.1	—	29	5	—	20	2	0.4	0.14
CSD17313Q2	30	10	1.3	—	32	5	—	20	2.1	0.4	0.15
CSD19538Q2	100	20	3.2	59	—	14.4	13.1	34.4	4.3	0.8	0.21

*Suggested resale price in U.S. dollars in quantities of 1,000.

Power MOSFETs

Selection Guide

N-Channel MOSFET Transistors (Continued)

Device	V _{DS} (V)	V _{GS} (V)	Typical V _{GS(th)} (V)	Maximum R _{DS(on)} (mΩ)		I _D , Package Limited (A)	I _D , Silicon Limited at T _C = 25°C (A)	I _{DM} (max), Pulsed Drain Current (A)	Typical Q _G (nC)	Typical Q _{GD} (nC)	Price*
				at 10 V	at 4.5 V						
SON 3x3 (QFN)											
CSD18543Q3A	60	20	2	9.9	15.6	35	60	156	11.1	1.7	0.27
CSD19537Q3	100	20	3	14.5	—	50	53	219	16	2.9	0.41
CSD19538Q3A	100	20	3.2	61	—	15	13.7	36	4.3	0.8	0.20
SON 3.3x3.3 (QFN)											
Dual FET Common Drain											
CSD87313DMS	30	10	0.9	—	5.5	—	—	—	28	6	0.66
Dual FET Common Source											
CSD87503Q3E	30	20	1.7	16.9	21.9	10	—	89	13.4	5.8	0.31
Single											
CSD17575Q3	30	20	1.4	2.3	3.2	60	182	240	23	5.4	0.35
CSD17581Q3A	30	20	1.3	3.8	4.7	60	101	154	20	4	0.25
CSD17577Q3A	30	20	1.4	4.8	6.4	35	83	239	13	2.8	0.21
CSD17578Q3A	30	20	1.5	7.3	9.4	20	54	142	7.9	1.7	0.19
CSD17579Q3A	30	20	1.5	10.2	14.2	20	39	106	5.3	1.2	0.17
CSD16327Q3	25	10	1.2	—	4.8	60	—	112	6.2	1.1	0.36
CSD16340Q3	25	10	0.85	—	5.5	60	—	115	6.5	1.2	0.37
SON 5x6 (QFN)											
Single											
CSD16570Q5B	25	20	1.5	0.59	0.82	100	456	400	95	31	0.82
CSD17570Q5B	30	20	1.5	0.69	0.92	100	407	400	93	34	0.83
CSD17573Q5B	30	20	1.4	1	1.45	100	332	400	49	11.9	0.60
CSD17576Q5B	30	20	1.4	2	2.9	100	184	400	25	5.4	0.43
CSD17581Q5A	30	20	1.3	3.4	4.2	60	123	256	20	4	0.27
CSD17577Q5A	30	20	1.4	4.2	5.8	60	83	280	13	2.8	0.23
CSD17578Q5A	30	20	1.5	6.9	9.3	25	59	132	7.9	2	0.21
CSD17579Q5A	30	20	1.5	9.7	13.3	25	46	105	5.4	1.2	0.19
CSD16415Q5	25	16	1.5	1.15	1.8	100	—	200	21	5.2	0.91
CSD16556Q5B	25	20	1.4	1.07	1.5	100	263	400	37	13	0.85
CSD17556Q5B	30	20	1.4	1.4	1.8	100	215	400	28.5	6.9	0.87
CSD18510Q5B	40	20	1.7	0.96	1.6	100	300	400	118	21	0.81
CSD18511Q5A	40	20	1.8	2.3	3.5	100	159	400	63	11.2	0.44
CSD18512Q5B	40	20	1.6	1.6	2.3	100	211	400	75	13.3	0.64
CSD18513Q5A	40	20	1.8	3.4	5.3	100	124	400	45	8.8	0.37
CSD18514Q5A	40	20	1.8	4.9	7.9	50	89	237	29	5	0.27
CSD18531Q5A	60	20	1.8	4.6	5.8	100	134	300	36	5.9	0.58
CSD18532NQ5B	60	20	2.8	3.4	—	100	163	400	49	7.9	0.84
CSD18532Q5B	60	20	1.8	3.2	4.3	100	172	400	44	—	0.84
CSD18533Q5A	60	20	1.9	5.9	8.5	100	103	267	29	5.4	0.46
CSD18534Q5A	60	20	1.9	9.8	12.4	50	69	229	17	3.5	0.33
CSD18537NQ5A	60	20	3	13	—	50	54	151	14	2.3	0.28
CSD18540Q5B	60	20	1.9	2.2	3.3	100	221	400	41	6.7	0.86
CSD18563Q5A	60	20	2	6.8	10.8	100	93	251	15	2.9	0.58
CSD19502Q5B	80	20	2.7	4.1	—	100	157	400	48	8.6	0.89
CSD19531Q5A	100	20	2.7	6.4	—	100	110	337	37	6.6	0.60
CSD19532Q5B	100	20	2.6	4.9	—	100	140	400	48	8.7	0.89
CSD19533Q5A	100	20	2.8	9.5	—	100	75	231	27	4.9	0.48
CSD19534Q5A	100	20	2.8	15.1	—	40	44	137	17	3.2	0.34

*Suggested resale price in U.S. dollars in quantities of 1,000.

Power MOSFETs

Selection Guide

N-Channel MOSFET Transistors (Continued)

Device	V _{DS} (V)	V _{GS} (V)	Typical V _{GS(th)} (V)	Maximum R _{DS(on)} (mΩ)		I _D , Package Limited (A)	I _D , Silicon Limited at T _C = 25°C (A)	I _{DM} (max), Pulsed Drain Current (A)	Typical Q _G (nC)	Typical Q _{GD} (nC)	Price*
				at 10 V	at 4.5 V						
T0-220											
Single											
CSD18502KCS	40	20	1.8	2.9	4.3	100	212	400	52	8.4	0.81
CSD18503KCS	40	20	1.9	4.5	6.8	100	142	358	30	4.6	0.58
CSD18504KCS	40	20	1.9	7	10	100	89	238	19	3.5	0.45
CSD18511KCS	40	20	1.8	2.6	4.2	110	194	400	64	9.7	0.56
CSD18532KCS	60	20	1.8	4.2	5.3	100	169	400	44	6.9	0.81
CSD18533KCS	60	20	1.9	6.3	9	100	118	293	28	3.9	0.58
CSD18534KCS	60	20	1.9	9.5	13.3	100	73	164	19	3.1	0.45
CSD18535KCS	60	20	1.9	2	2.9	200	279	400	63	10.4	1.19
CSD18536KCS	60	20	1.8	1.6	2.2	200	349	400	83	14	1.79
CSD18537NKCS	60	20	3	14	—	50	56	147	14	2.3	0.40
CSD19501KCS	80	20	2.6	6.6	—	100	129	305	38	5.8	0.72
CSD19503KCS	80	20	2.8	9.2	—	100	94	247	28	5.4	0.59
CSD19505KCS	80	20	2.6	3.1	—	150	208	400	76	11	1.24
CSD19506KCS	80	20	2.5	2.3	—	150	273	400	120	20	1.87
CSD19531KCS	100	20	2.7	7.7	—	100	110	285	38	7.5	0.72
CSD19533KCS	100	20	2.8	10.5	—	100	86	207	27	5.4	0.60
CSD19534KCS	100	20	2.8	16.5	—	100	54	138	16.4	3.3	0.46
CSD19535KCS	100	20	2.7	3.6	—	150	187	400	78	13	1.24
CSD19536KCS	100	20	2.5	2.7	—	150	259	400	118	17	1.87
D2PAK											
Single											
CSD18511KTT	40	20	1.8	2.6	4.2	110	194	400	64	9.7	0.61
CSD18542KTT	60	20	1.8	4	5.1	200	170	400	44	6.9	0.76
CSD18535KTT	60	20	1.9	2	2.9	200	279	400	63	10.4	1.24
CSD18536KTT	60	20	1.8	1.6	2.2	200	349	400	108	14	1.84
CSD19505KTT	80	20	2.6	3.1	—	200	212	400	76	11	1.29
CSD19506KTT	80	20	2.5	2.3	—	200	291	400	120	20	1.92
CSD19532KTT	100	20	2.6	5.6	—	200	136	400	44	17	0.91
CSD19535KTT	100	20	2.7	3.4	—	200	197	400	75	11	1.29
CSD19536KTT	100	20	2.5	2.4	—	200	272	400	118	17	1.92

*Suggested resale price in U.S. dollars in quantities of 1,000.

Power MOSFETs

Selection Guide

P-Channel MOSFET Transistors

Device	V _{DS} (V)	V _{GS} (V)	Typical V _{GS(th)} (V)	Maximum R _{DS(on)} (mΩ)			I _D (max) Continuous (A)	I _{DM} (max), Pulsed Drain Current (A)	Typical Q _G (nC)	Typical Q _{GS} (nC)	Typical Q _{GD} (nC)	Price*
				at 4.5 V	at 2.5 V	at 1.8 V						
LGA 0.64x73 (CSP)												
Single FET												
CSD25501F3	-20	-20	-0.75	76	125	260	-3.6	-13.6	1.02	0.45	0.09	0.06
CSD25480F3	-20	-12	-0.95	159	260	840	-1.7	-10.4	0.7	0.26	0.1	0.05
CSD23280F3	-12	-6	-0.65	116	165	250	-1.8	-11.4	0.95	0.3	0.068	0.05
LGA 0.6x1 (CSP)												
Single FET												
CSD25481F4	-20	-12	-0.95	105	175	800	-2.5	-10	0.913	0.24	0.153	0.06
CSD25483F4	-20	-12	-0.95	245	390	1070	-1.6	-6.5	0.96	0.25	0.16	0.05
CSD25484F4	-20	-12	-0.95	109	180	825	-2.5	-22	1.09	0.35	0.15	0.07
CSD23381F4	-12	-8	-0.95	175	300	970	-2.3	-9	1.14	0.3	0.19	0.05
CSD23382F4	-12	-8	-0.8	76	105	199	-3.5	-22	1.04	0.5	0.15	0.07
LGA 0.77x1.53 (CSP)												
Single FET												
CSD25485F5	-20	-12	-0.95	42	70	250	-5.3	-31	2.7	0.67	0.56	0.10
CSD23285F5	-12	-6	-0.65	35	47	80	-3.3	-31	3.2	0.66	0.48	0.10
LGA 1.2x1.2 (CSP)												
CSD22205L	-8	-6	-0.7	9.9	15	40	-7.4	-71	6.5	1.2	1.0	0.13
WLP 1x1 (CSP)												
Single FET												
CSD23202W10	-12	-6	-0.6	53	66	92	-2.2	-25	2.9	0.55	0.28	0.11
CSD25213W10	-20	-6	-0.85	47	67	—	-1.6	-16	2.2	0.74	0.14	0.09
WLP 1x1.5 (CSP)												
Single FET												
CSD23203W	-8	-6	-0.8	19.4	26.5	53	-3	-54	4.9	1.3	0.6	0.14
CSD25211W1015	-20	-6	-0.8	33	44	—	-3.2	-9.5	3.4	1.1	0.2	0.14
CSD25304W1015	-20	-8	-0.8	32.5	45.5	92	-3	-41	3.3	0.7	0.5	0.14
Dual Common Source												
CSD75208W1015	-20	-6	-0.8	108	150	285	-1.6	-22	1.9	0.48	0.23	0.15
WLP 1.5x1.5 (CSP)												
Single FET												
CSD22206W	-8	-6	-0.7	5.7	9.1	—	-5	-108	11.2	2.1	1.8	0.23
CSD22204W	-8	-6	-0.7	9.9	14	—	-5	-80	18.9	3.2	4.2	0.18
CSD22202W15	-8	-6	-0.8	12.2	17.4	—	-5	-48	6.5	1.6	1	0.18
CSD25202W15	-20	-6	-0.75	26	32	52	-4	-38	5.8	1.1	0.8	0.19
Dual Common Source												
CSD75207W15	-20	-6	-0.8	27	39	81	-3.9	-24	2.9	0.7	0.4	0.20
SON 2x2 (QFN)												
Single FET												
CSD25310Q2	-20	-8	-0.85	23.9	32.5	89	-9.6	-48	3.6	1.1	0.5	0.15
SON 3.3x3.3 (QFN)												
Single FET												
CSD25404Q3	-20	-12	-0.9	6.5	12.1	150	-18	-240	10.8	2.8	2.2	0.38
CSD25402Q3A	-20	-12	-0.9	8.9	15.9	300	-15	-82	7.5	2.4	1.1	0.29

*Suggested resale price in U.S. dollars in quantities of 1,000.

Power MOSFETs

Selection Guide

CSD9xxx NexFET™ Power Stage integrates enhanced gate drivers with two MOSFETs in TI's PowerStack™ package

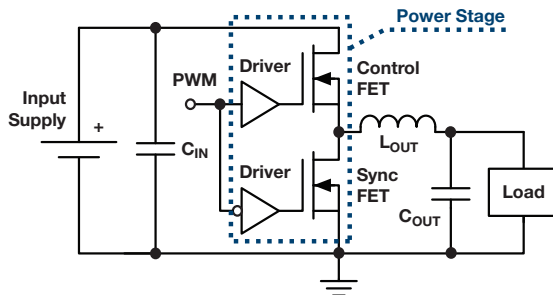

CSD8xxx NexFET Power Block and Power Block II families contain an optimized MOSFET pair in innovative packages

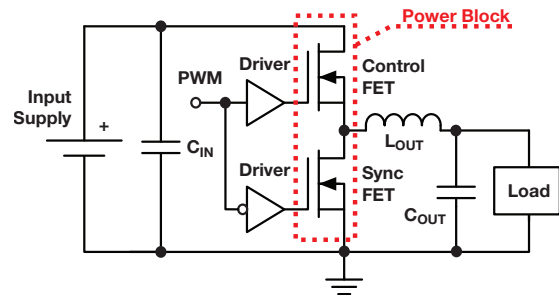

NexFET™ Power-Stage MOSFETs

Device	Max V _{IN} (V)	Power Loss (W)	P _{LOSS} Current (A)	Current Sense	Temperature Sense	DualCool™ Package	Maximum Current (A)	Price*
SON 3x3								
CSD95379Q3M	16	1.8	12	No	No	No	20	0.59
SON 3.5x4.5								
CSD95375Q4M	16	2.2	15	No	No	No	25	0.79
CSD95377Q4M	16	1.6	15	No	No	No	35	0.88
CSD97394Q4M	24	2.2	12	No	No	No	20	0.64
CSD97395Q4M	24	2.3	15	No	No	No	25	0.77
CSD97396Q4M	24	2	15	No	No	No	30	0.84
SON 5x6								
CSD95372AQ5M	16	3.3	30	No	Yes	No	60	1.54
CSD95372BQ5M	16	2.8	30	Yes	Yes	No	60	1.87
CSD95372BQ5MC	16	2.8	30	Yes	Yes	Yes	60	2.06
CSD95373AQ5M	16	2.6	25	No	Yes	No	45	1.21
CSD95373BQ5M	16	2.6	25	Yes	Yes	No	45	1.65
CSD95378BQ5M	16	2.8	30	Yes	Yes	No	60	1.87
CSD95378BQ5MC	16	2.8	30	Yes	Yes	Yes	60	2.06
CSD95472Q5MC	16	2.3	30	Yes	Yes	Yes	60	2.15
CSD96370Q5M	13.2	2.6	25	No	No	No	40	1.28
CSD96371Q5M	13.2	2.4	25	No	No	No	50	1.36
CSD97370AQ5M	22	2.8	25	No	No	No	40	1.28
CSD97370Q5M	22	2.8	25	No	No	No	40	1.28
CSD95480RWJ	16	2.3	30	Yes	Yes	No	70	2.20
CSD95481RWJ	16	2.7	30	Yes	Yes	No	60	1.91
CSD95482RWJ	16	1.6	20	Yes	Yes	No	40	1.78
CSD95490Q5MC	16	2.25	30	Yes	Yes	Yes	75	2.48
CSD95491Q5MC	16	2.6	30	Yes	Yes	Yes	60	1.96
SON 4x5								
CSD95492QVM	16	0.89	12	Yes	Yes	No	20	1.36
CSD95495QVM	16	2.3	25	Yes	Yes	No	50	1.72
CSD95496QVM	16	1.8	20	Yes	Yes	No	40	1.54

*Suggested resale price in U.S. dollars in quantities of 1,000.

NexFET Power-Block MOSFETs

Device	Attributes	V _{DS} (V)	V _{GS} (V)	Power Loss (W)	P _{LOSS} Current (A)	Maximum Current (A)	Price*
LGA							
CSD87381P	N-Channel	30	10	1	8	15	0.30
CSD87588N	N-Channel	30	20	2.1	15	25	0.46
CSD87384M	N-Channel	30	10	3.7	25	30	0.63
SON 3x3							
CSD86330Q3D	N-Channel	25	10	1.9	15	20	0.70
CSD87330Q3D	N-Channel	30	10	2	15	20	0.59
CSD87331Q3D	N-Channel	30	10	1.3	10	15	0.46
CSD87333Q3D	N-Channel	30	10	1.5	8	15	0.44
CSD87334Q3D	N-Channel	30	10	1.6	12	20	0.55
CSD87335Q3D	N-Channel	30	10	1.5	15	25	0.64
SON 5x6							
CSD86350Q5D	N-Channel	25	10	2.8	25	40	0.95
CSD86360Q5D	N-Channel	25	10	2.6	25	50	0.99
CSD87350Q5D	N-Channel	30	10	3	25	40	0.95
CSD87351Q5D	N-Channel	30	10	2.5	20	32	0.79
CSD87351ZQ5D	N-Channel	30	10	2.5	20	32	0.79
CSD87352Q5D	N-Channel	30	10	1.8	15	25	0.66
CSD87353Q5D	N-Channel	30	10	3.3	25	40	1.08
CSD87355Q5D	N-Channel	30	10	2.8	25	45	0.95
CSD88584Q5DC	N-Channel	40	20	2.4	35	50	2.24
CSD88599Q5DC	N-Channel	60	20	3.0	30	40	2.50

*Suggested resale price in U.S. dollars in quantities of 1,000.

High-Voltage Power: AC/DC and Isolated DC/DC MOSFET and IGBT Gate Drivers

TI's portfolio of over 100 gate drivers delivers the industry's fastest switching power while meeting a large range of specifications. Benefits include robust designs with fast turn-on/off times at high switching frequencies, which reduces power loss and achieves better system performance. TI's family of gate drivers include low-side drivers, half-bridge drivers and isolated drivers.

Low-Side Gate Drivers

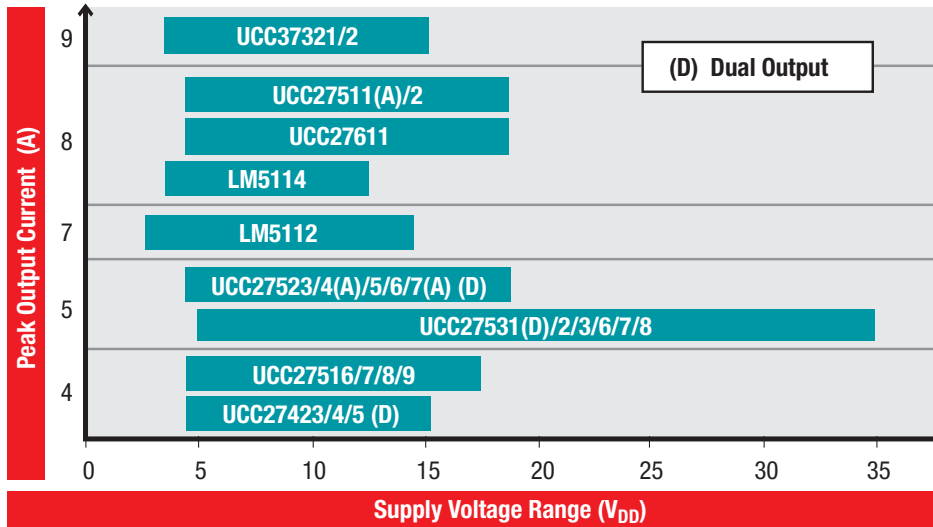

Product Highlights

UCC2751x and UCC2752x

- A version for select products
- AEC-Q100 qualified for select products
- Asymmetrical drive and split-output options available on select single-channel drivers
- Best-in-class propagation delay and higher V_{DD} compatibility with MOSFET power switches
- Both families feature TTL and CMOS input thresholds

UCC27531, UCC27531-Q1

- Available in D and DBV packaging
- FET and IGBT single-gate drivers
- 2.5 A and 5 A, 35-V maximum V_{DD}

Low-Side Gate Drivers

Device	No. of Channels	Power Switch	Peak I _{OUT} Source/Sink (A)	V _{CC} Range (V)	Rise/Fall Time (ns)	Prop Delay (ns)	Input Threshold	Channel Input Logic	Special Features	Automotive Grade	Price*
UCC27524A	2	MOSFET, IGBT, GaNFET	5/5	4.5 to 18	7/6	13	TTL	Dual, Non-Inverting	Enable Pin, Negative Voltage Handling on Input, 1-ns delay matching between channels	✓	0.75
UCC27525	2	MOSFET, IGBT, GaNFET	5/5	4.5 to 18	7/6	13	TTL	Inverting, Non-Inverting	Enable Pin, 1-ns delay matching between channels		0.75
UCC27526	2	MOSFET, IGBT, GaNFET	5/5	4.5 to 18	7/6	13	TTL	Flexible	1-ns delay matching between channels		0.75
UCC27528	2	MOSFET, IGBT, GaNFET	5/5	4.5 to 18	7/6	17	CMOS	Dual, Non-Inverting	Negative Voltage Handling on Input	✓	0.75
UCC27523	2	MOSFET, IGBT, GaNFET	5/5	4.5 to 18	7/6	13	TTL	Dual, Inverting	Enable Pin, 1-ns delay matching between channels		0.75
UCC27511	1	MOSFET, IGBT, GaNFET	4/8	4.5 to 18	8/7	13	Dual input TTL, CMOS	Inverting, Non-Inverting	Split Output	✓	0.49
UCC27512	1	MOSFET, IGBT, GaNFET	4/8	4.5 to 18	8/7	13	Dual input TTL, CMOS	Inverting, Non-Inverting			0.49
UCC27516	1	MOSFET, IGBT, GaNFET	4/4	4.5 to 18	8/7	13	TTL	Inverting, Non-Inverting			0.49
UCC27517A	1	MOSFET, IGBT, GaNFET	4/4	4.5 to 18	8/7	13	TTL	Inverting, Non-Inverting	Negative Voltage Handling on Input	✓	0.49
UCC27518	1	MOSFET, IGBT, GaNFET	4/4	4.5 to 18	8/7	17	CMOS	Inverting	Enable Pin	✓	0.49
UCC27519	1	MOSFET, IGBT, GaNFET	4/4	4.5 to 18	8/7	17	CMOS	Non-Inverting	Enable Pin	✓	0.49
UCC27531	1	MOSFET, IGBT, SiCFET	-2.5/5	10 to 32	15/7	17	CMOS, TTL	Non-Inverting, Single	Split Output, Negative Voltage Handling on Input, Enable Pin	✓	0.75
UCC27532	1	MOSFET, IGBT, SiCFET	-2.5/5	10 to 32	15/7	17	CMOS	Single, Non-Inverting	Split Output, Negative Voltage Handling on Input	✓	0.75
UCC27533	1	MOSFET, IGBT, SiCFET	-2.5/5	10 to 32	15/8	15	TTL	Dual, Inverting, Non-Inverting	Negative Voltage Handling on Input		0.75
UCC27536	1	MOSFET, IGBT, SiCFET	-2.5/5	10 to 32	15/8	15	TTL	Single, Inverting	Enable Pin, Negative Voltage Handling on Input		0.75

*Suggested resale price in U.S. dollars in quantities of 1,000.

High-Voltage Power: AC/DC and Isolated DC/DC

MOSFET and IGBT Gate Drivers

Low-Side Gate Drivers (Continued)

Device	No. of Channels	Power Switch	Peak I _{OUT} Source/Sink (A)	V _{CC} Range (V)	Rise/Fall Time (ns)	Prop Delay (ns)	Input Threshold	Channel Input Logic	Special Features	Automotive Grade	Price*
UCC27537	1	MOSFET, IGBT, SiC FET	-2.5/5	10 to 32	15/8	15	TTL	Single, Non-Inverting	Enable Pin, Negative Voltage Handling on Input		0.75
UCC27538	2	MOSFET, IGBT, SiC FET	-2.5/5	10 to 32	15/8	15	TTL	Dual, Non-Inverting	Split Output, Negative Voltage Handling on Input		0.75
UCC27611	1	MOSFET, IGBT, GaNFET	-4/6	4 to 18	5/5	14	TTL	Inverting, Non-Inverting	Split Output		0.85
UCC37321	1	MOSFET, IGBT, GaNFET	9/9	4 to 15	20/20	30	TTL/CMOS	Inverting	Enable Pin		0.99
UCC37322	1	MOSFET, IGBT, GaNFET	9/9	4 to 15	20/20	30	TTL/CMOS	Non-Inverting	Enable Pin		0.99
LM5112	2	MOSFET	7/3	3.5 to 15	14/12	25	CMOS	Inverting, Non-Inverting	Negative Output Voltage Capability	✓	0.45
LM5111	2	MOSFET	5/3	3.5 to 15	14/12	25	TTL	Inverting, Non-Inverting, Combination	UVLO Configured to Drive PFET through OUT_A		0.58
LM5110	2	MOSFET	5/2	3.5 to 15	14/12	25	TTL	Inverting, Non-Inverting, Combination	Negative Output Voltage Capability		0.58
LM5114A/B	1	MOSFET, IGBT, GaNFET	1.3/7.6	4 to 12.6	8/3.2	12	TTL/CMOS	Inverting, Non-Inverting	Controllable Rise and Fall Times		0.60
LM5134	2	MOSFET, GaNFET	4.5/7.6 / 0.66/0.82	4 to 12.6	5.3/4.7	12	TTL/CMOS	Inverting, Non-Inverting	Pilot Output		0.60
UCD7100PWP	1	MOSFET	4/4	4.5 to 16	10/10	20	TTL/CMOS				0.99
UCD7201PWP	2	MOSFET	4/4	4.5 to 16	10/10	20	TTL/CMOS				1.20
TPS2812	2	MOSFET	2/2	4 to 40	25/25	40	CMOS	Non-Inverting	Internal Regulator		0.90
TPS2814	2	MOSFET	2/2	4 to 14	25/25	40	CMOS	2 Input AND	2-Input Gates Each Channel		0.90
SM72482	2	MOSFET	5/3	3.5 to 15	14/12	25	TTL	Inverting, Non-Inverting, Combination	PFET Drive Capability		0.62
SM74101	1	MOSFET	7/3	3.5 to 15	14/12	25	CMOS	Inverting, Non-Inverting			0.50
TPS2811	2	MOSFET	2/2	4 to 14	14/15	25	CMOS	Inverting	Internal Regulator		0.87
TPS2813	2	MOSFET	2/2	4 to 14	14/15	25	CMOS	Inverting, Non-Inverting	Internal Regulator		1.05
TPS2815	2	MOSFET	2/2	4 to 14	14/15	25	CMOS	2 Input NAND	2-Input Gates Each Channel		0.75
TPS2816	1	MOSFET	2/2	4 to 14	14/14	24	CMOS	Inverting, Active Pullup	Internal Regulator		0.75
TPS2817	1	MOSFET	2/2	4 to 14	14/14	24	CMOS	Non-Inverting, Active Pullup	Internal Regulator		0.75
TPS2818	1	MOSFET	2/2	4 to 14	14/14	24	CMOS	Inverting	Internal Regulator		0.75
TPS2819	1	MOSFET	2/2	4 to 14	14/14	24	CMOS	Non-Inverting	Internal Regulator		0.75
UCC27321	1	MOSFET, IGBT, GaNFET	9/9	4 to 15	20/20	25	TTL/CMOS	Inverting	Enable Pin	✓	1.10
UCC27322	1	MOSFET, IGBT, GaNFET	9/9	4 to 15	20/20	25	TTL/CMOS	Non-Inverting	Enable Pin	✓	1.10
UCC27323	2	MOSFET, IGBT, GaNFET	4/4	4.5 to 15	20/15	25	TTL/CMOS	Inverting			0.75
UCC27324	2	MOSFET, IGBT, GaNFET	4/4	4.5 to 15	20/15	25	TTL/CMOS	Non-Inverting			0.75
UCC27325	2	MOSFET, IGBT, GaNFET	4/4	4.5 to 15	20/15	25	TTL/CMOS	Inverting, Non-Inverting			0.75
UCC27423	2	MOSFET, IGBT	4/4	4 to 15	20/15	25	TTL/CMOS	Inverting	Enable Pin	✓	0.75
UCC27424	2	MOSFET, IGBT	4/4	4 to 15	20/15	25	TTL/CMOS	Non-Inverting	Enable Pin	✓	0.75
UCC27425	2	MOSFET, IGBT	4/4	4 to 15	20/15	25	TTL/CMOS	Inverting, Non-Inverting	Enable Pin	✓	0.75
UCC27527	2	MOSFET, IGBT, GaNFET	5/5	4.5 to 18	7/6	17	CMOS	Dual, Flexible, Inverting, Non-Inverting	Negative Voltage Handling on Input		0.75

*Suggested resale price in U.S. dollars in quantities of 1,000.

High-Voltage Power: AC/DC and Isolated DC/DC MOSFET and IGBT Gate Drivers

Half-Bridge Gate Drivers

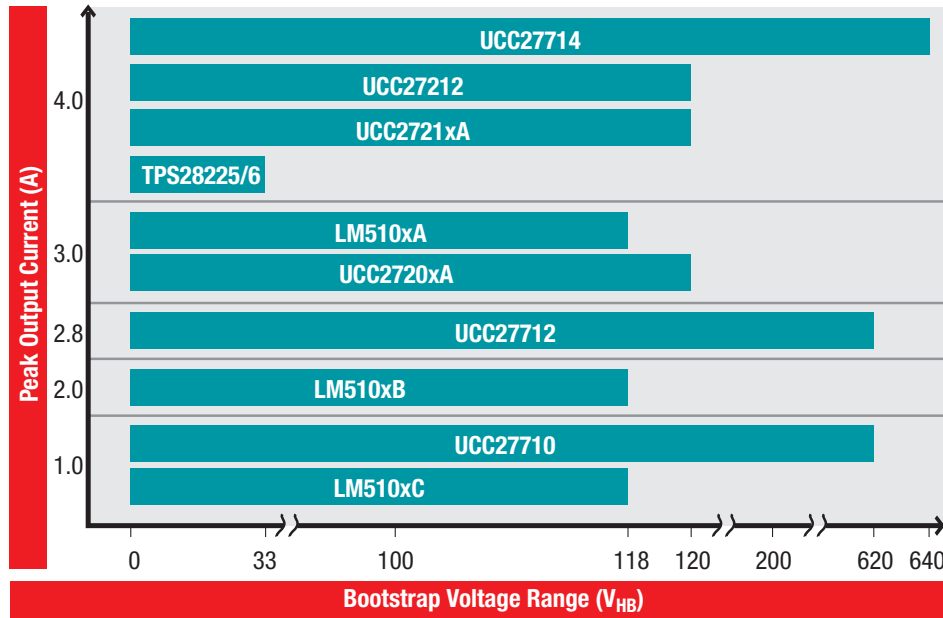

Product Highlights

UCC2771x Family

- 600-V high-side and low-side gate drivers
- Stable propagation delay versus temperature
- Robust negative voltage capability

LM510xx Family

- Drive capability scales with power-converter requirements

UCC2721x

- 4-A next generation of popular UCC2720x
- 120-V boot voltage
- -10-V input voltage capability and ESD enhancements

Half-Bridge Gate Drivers

Device	No. of Channels	Power Switch	Bus Voltage (V)	Peak I _{OUT} Source/Sink (A)	V _{CC} Range (V)	Rise/Fall Time (ns)	Prop Delay (ns)	Input Threshold	Special Features	Automotive Grade	Price*
TPS28225	2	MOSFET	to 24	6/6	4.5 to 8	10/5	14	TTL	Synchronous Rectification	✓	0.59
TPS2849	2	MOSFET	to 29	4/4	10 to 15	120	20	TTL	Dead Time Control, Synchronous Rectification		1.25
UCC27222	2	MOSFET	to 12	3.3/3.3	3.7 to 20	20/20	82/103	TTL	Dead Time Control, Soft Switching, Synchronous Rectification		1.70
UCC27223	2	MOSFET	to 20	3.3/3.3	-0.3 to 20	25/35	82/103	TTL	Dead Time Control, Soft Switching, Synchronous Rectification		1.70
TPS2833	2	MOSFET	to 28	2.4/2.4	4.5 to 15	50/50	75	CMOS	Dead Time Control, Synchronous Rectification		1.00
TPS2837	2	MOSFET	to 28	2.4/2.4	4.5 to 15	30/30	70	TTL	Dead Time Control, Synchronous Rectification		1.25
TPS28226	2	MOSFET	to 24	2/4	6.8 to 8	10/10	14	TTL/CMOS	Synchronous Rectification		0.60
LM5100A/B/C	2	MOSFET	to 100	3/3	9 to 14	8/8	25	CMOS			1.25
LM5101A/B/C	2	MOSFET	to 100	3/3	9 to 14	8/8	25	TTL			1.25
LM5104	2	MOSFET	to 100	2/2	9 to 14	10/10	35	TTL			1.10
LM5105	2	MOSFET	to 100	2/2	8 to 14	10/10	25	TTL			0.90
LM5106	3	MOSFET	to 100	1.8/1.8	8 to 14	15/10	32	TTL	Dead Time Control		0.64
LM5109B	2	MOSFET	to 110	1/1	8 to 14	15/15	25	TTL			0.60
SM72295	4	MOSFET	to 100	3/3	8 to 14	8/8	22	TTL			1.90
UCC27212	2	MOSFET, IGBT, GaNFET	to 120	4/4	5 to 17	7.2/5.5	20	TTL	Negative Voltage Handling		1.50
UCC27200/A	2	MOSFET	to 110	3/3	8 to 17	8/7	20	CMOS		✓	1.30
UCC27201/A	2	MOSFET	to 110	3/3	8 to 17	8/7	20	TTL	Negative Voltage Handling	✓	1.30
UCC27210	2	MOSFET, IGBT, GaNFET	to 110	4/4	8 to 17	12/9	20	CMOS	Negative Voltage Handling		1.50
UCC27211/A	2	MOSFET, IGBT, GaNFET	to 110	4/4	8 to 17	12/9	20	TTL	Negative Voltage Handling		1.50
SM74104	2	MOSFET	to 110	1.8/1.8	9 to 14	15/15	25	TTL			1.10
UCC27710	2	MOSFET, IGBT	to 620	2.8/2.8	10 to 22	40/20	100	TTL/CMOS	Interlock, Negative Voltage Handling		0.80
UCC27712	2	MOSFET, IGBT	to 620	2.8/2.8	10 to 22	16/10	100	TTL/CMOS	Interlock, Negative Voltage Handling		0.90
UCC27714	2	MOSFET, IGBT	to 600	4/4	10 to 18	15/15	90	TTL/CMOS	Negative Voltage Handling		1.75

*Suggested resale price in U.S. dollars in quantities of 1,000.

New devices are listed in bold red.

High-Voltage Power: AC/DC and Isolated DC/DC

MOSFET and IGBT Gate Drivers

Isolated Gate Drivers

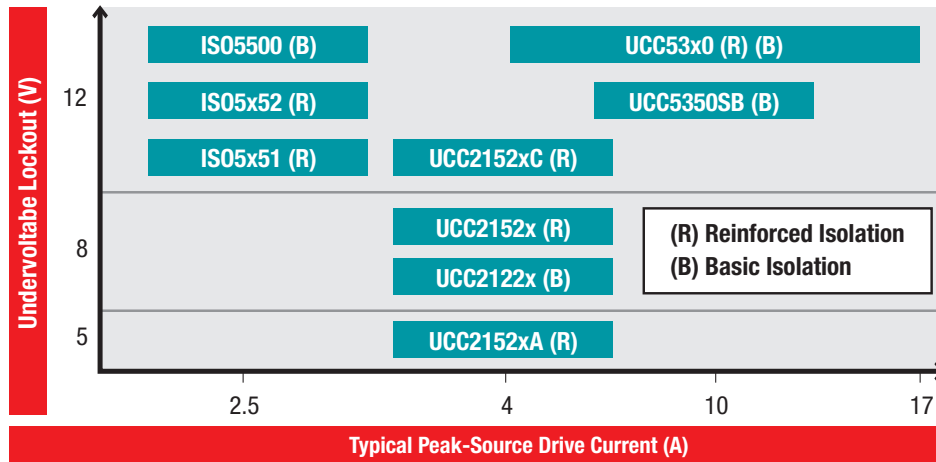

Product Highlights

UCC2152x

- 5.7-kV_{RMS} reinforced isolation
- Peak drive current (source/sink): 4 A/6 A
- Short propagation delay for better response/control

UCC53x0

- 3-kV_{RMS} and 5.7-kV_{RMS} variants
- Single-channel isolated family
- Propagation delay: 65 ns
- Drives MOSFET and IGBT

ISO54/585x

- 5.7-kV_{RMS} reinforced isolation
- Single-channel driver family (source/sink): 2.5 A/5 A
- Safety features: Miller clamp, Desat detect, fault feedback, auto soft-shutdown on short
- Drives IGBT and SiC FET

Isolated Gate Drivers

Device	Description	UL 1577 Isolation Voltage (Single) (Vrms)	DIN V VDE V 0884-10 Transient Overvoltage Rating (Vpk)	DIN V VDE V 0884-10 Surge Voltage Rating (Vpk)	DIN V VDE V 0884-10 Working Voltage (Vpk)	Number of Channels(#)	Power Switch	Output V _{CC} /V _{DD} (max) (V)	Output V _{CC} /V _{DD} (min) (V)	Input V _{CC} (min) (V)	Input V _{CC} (max) (V)	Peak Output Current (A)	Prop Delay (ns)	Operating Temperature Range (°C)	Package Group	Estimated Package Size (WxL) (mm ²)	Automotive Grade	Price*
UCC5310	2-A/1-A, 3-kV _{RMS} Single-Channel Isolated Gate Driver With Miller Clamp	3000	4242	4242	990	1	IGBT, SiC	33	13.2	3	15	4.3	60	-40 to 125	SOIC	8-SOIC (3.9 x 4.9) (30 mm ²)		0.91
UCC5320	2-A/2-A, 3-kV _{RMS} Single-Channel Isolated Gate Driver for Bipolar Supply (E) or With Split Output (S)	3000	4242	4242	990	1	IGBT, SiC	33	13.2	3	15	4.3	60	-40 to 125	SOIC	8-SOIC (3.9 x 4.9) (30 mm ²)		0.91
UCC5350	5-A/5-A, 3-kV _{RMS} Single-Channel Isolated Gate Driver With Miller Clamp	3000	4242	4242	990	1	IGBT, SiC	33	13.2	3	15	10	60	-40 to 125	SOIC	8-SOIC (3.9 x 4.9) (30 mm ²)		1.00
UCC5350SB	5-A/5-A, 3-kV _{RMS} Single-Channel Isolated Gate Driver With Split Output	3000	4242	4242	990	1	IGBT, SiC, MOSFET	33	9.5	3	15	10	65	-40 to 125	SOIC	8-SOIC (3.9 x 4.9) (30 mm ²)		1.00
UCC5390	10-A/10-A 3-kV _{RMS} Single-Channel Isolated Gate Driver for Bipolar Supply (E) or With Split Output (S)	3000	4242	4242	990	1	IGBT, SiC	33	13.2	3	15	17	60	-40 to 125	SOIC	8-SOIC (3.9 x 4.9) (30 mm ²)		1.05
ISO5451	Reinforced Isolated IGBT Gate Driver with High CMTI & Miller Clamp	5700	8000	6000	1420	1	IGBT	30	15	3	5.5	5	110	-40 to 125	SOIC	16-SOIC (7.5 x 10.3) (98 mm ²)		2.00
ISO5452	Isolated IGBT Gate Driver with High CMTI, Split Outputs & Safety Features	5700	8000	6000	1420	1	IGBT	30	15	2.25	5.5	5	110	-40 to 125	SOIC	16-SOIC (7.5 x 10.3) (98 mm ²)		2.25
ISO5500	2.5-A Isolated IGBT/MOSFET Gate Driver	4243	6000	6000	680	1	IGBT	30	15	3	5.5	2.5	300	-40 to 125	SOIC	16-SOIC (7.5 x 10.3) (98 mm ²)		3.00
ISO5851	Reinforced Isolated IGBT Gate Driver with High CMTI & Miller Clamp	5700	8000	8000	2121	1	IGBT	30	15	3	5.5	5	110	-40 to 125	SOIC	16-SOIC (7.5 x 10.3) (98 mm ²)		3.20

*Suggested resale price in U.S. dollars in quantities of 1,000.

New devices are listed in bold red.

High-Voltage Power: AC/DC and Isolated DC/DC MOSFET and IGBT Gate Drivers

Isolated Gate Drivers (Continued)

Device	Description	UL 1577 Isolation Voltage (Single) (Vrms)	DIN V VDE V 0884-10 Transient Overvoltage Rating (Vpk)	DIN V VDE V 0884-10 Surge Voltage Rating (Vpk)	DIN V VDE V 0884-10 Working Voltage (Vpk)	Number of Channels(#)	Power Switch	Output V_{CC}/V_{DD} (max) (V)	Output V_{CC}/V_{DD} (min) (V)	Input V_{CC} (min) (V)	Input V_{CC} (max) (V)	Peak Output Current (A)	Prop Delay (ns)	Operating Temperature Range (°C)	Package Group	Estimated Package Size (WxL) (mm ²)	Automotive Grade	Price*
ISO5852S	Reinforced Isolated IGBT Gate Driver with High CMTI, Split Outputs & Safety Features	5700	8000	8000	2121	1	IGBT	30	15	2.25	5.5	5	110	-40 to 125	SOIC	16-SOIC (7.5 x 10.3) (98 mm ²)		3.50
UCC21520	2-Channel Isolated Gate Driver	5700	8000	12800	1414	2	Si FETSiC	30	4.5	3	18	4/6	30	-40 to 125	SOIC	16-SOIC (7.5 x 10.3) (98 mm ²)	✓	1.75
UCC21225A	Dual-Channel Isolated Gate Driver	2500	3535	3535	792	2	MOSFET	25	6.5	3	18	6	19	-40 to 125	VLGA	13-NPL LGA (5x5) (25 mm ²)		1.96

*Suggested resale price in U.S. dollars in quantities of 1,000.

New devices are listed in bold red.

Automotive-Grade Gate Drivers

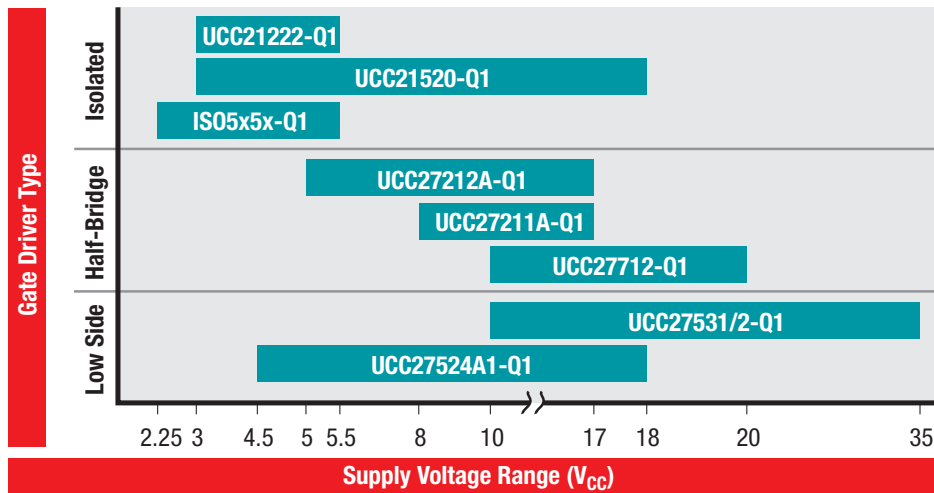

Product Highlights

UCC21222-Q1

- Dual channel
- 3-kV_{RMS} basic isolation
- 4-A/6-A drive current
- 25-ns propagation delay

ISO54/585x-Q1

- Single channel
- Safety features: Miller clamp, Desat detect, fault feedback
- Drives IGBT and SiC FET

UCC27712-Q1

- 620 V, 1.8-A/2.8-A drive current
- 100-ns propagation delay

UCC27524A1-Q1

- Dual channel
- 18 V, 5-A/5-A drive current
- 13-ns propagation delay

Automotive-Grade Featured Products

Device	Description	Features	Benefits	Applications	Automotive Grade
UCC21520	2-channel isolated gate driver	Dual-driver, 5-kV RMS input-to-output, 1.5-kV ch-to-ch iso, 4-A source/6-A sink, CMTI > 50 V/ns, 30-ns prop delay, 8-V UVLO	Drop-in replacement, high(er) drive can eliminate buffer stages, flexible settings to prevent shoot-through in half bridge, provides high noise immunity for fast/high current designs	AC/DC and isolated DC/DC converters, high-frequency inverters, motor drives, UPS, solar power, Si and SiC MOSFET gate applications	✓
UCC27712	620-V, 1.8-A, 2.8-A high-side low-side gate driver with interlock	Best-in-class prop delay (100 ns typical), output enable, separate logic/power grounds, 8-pin SOIC	Prevents cross conduction, supports higher power applications for increased robustness, higher negative-voltage tolerance, ability to handle high dv/dt for increased overall system efficiency	Motor drive, bridge converters in offline AC/DC power supplies, server, telecom, it, industrial infrastructures, DC/AC inverters	✓
UCC27201A	120-V boot, 3-A peak, high-frequency, high-side/low-side driver	Dual channel with independent inputs, internal bootstrap diode, up to 1-MHz operation, tight propagation delay matching below high side and low side drive, -18-V negative voltage handling	Improved MTBF calculations, design margin reduces the need of external components, supports higher power density designs, better flux balance	Power supplies, half- and full-bridge applications, isolated bus architecture, two-switch and active-clamp converters	✓
UCC27531 UCC27531D	2.5-A, 5-A, 35-V _{MAX} V _{DD} FET and IGBT single-gate driver	Fastest propagation time (17-ns typical), UVLO setting and rail-to-rail output voltage, negative input-voltage handling, split output	Built-in level shifting, inverting and non-inverting configurations, matches parasitic and improves layout, reduced overall cost	Solar inverters, motor control, UPS, HEV/EV chargers, switch-mode power, intelligent power modules	✓

High-Voltage Power: AC/DC and Isolated DC/DC

MOSFET and IGBT Gate Drivers

Automotive-Grade Featured Products (Continued)

Device	Description	Features	Benefits	Applications	Automotive Grade
UCC27517A	4-A, single channel high-speed low-side gate driver with negative input voltage handling ability	Ability to handle negative voltages (–5 V) at inputs, fast propagation delay (13-ns typical), fast rise and fall times (9-ns and 7-ns typical), hysteretic-logic thresholds for high-noise immunity	Extremely-low pulse-transmission distortion with accurate timing & loop control, compatibility with emerging wide band-gap power devices, allows inverting or non-inverting option at the input	Switch-mode power supplies, DC/DC converters, solar power, motor control, UPS	✓
UCC27524A	Dual 5-A, high-speed, low-side gate driver with negative input-voltage capability	Two independent gate-drive channels, independent-enable function for each output, fast propagation delays (13-ns typical), fast rise and fall times (7-ns and 6-ns typical), 1-ns typical delay matching between 2-channels	Extremely-low pulse-transmission distortion allows accurate timing & loop control, outputs low when IN floats improves system reliability and allows to pass abnormal condition tests easily for safety certification, high peak current allows fast switching and low rise/fall times (7-ns/6-ns typical with 1.8-nF load)	Switch-mode power supplies, DC/DC converters, solar power, motor control, UPS	✓

Automotive-Grade Gate Drivers

Device	Description	Max V _{CC} (V)	Peak Current (A)	Prop Delay (ns)	Pin/Package	Automotive Grade
IS05452-Q1	High-CMTI 2.5-A/5-A Isolated IGBT, MOSFET Gate Driver With Split Outputs and Protection Features	6	5	76	16SOIC	✓
IS05852S-Q1	High-CMTI 2.5-A/5-A Isolated IGBT, MOSFET Gate Driver With Split Outputs and Protection Features	6	5	76	16SOIC	✓
TPS28225-Q1	Automotive catalog 8-pin high frequency 4-A sink synchronous MOSFET driver	8.8	6	14	SOIC, SON	✓
UCC21222-Q1	4-Asource, 6-A sink peak current, 3.0-kVrms Isolated Dual-Channel Gated Driver	6	6	25	16SOIC	✓
UCC21520-Q1	2-channel isolated gate driver	30	4/6	30	SOIC	✓
UCC27201A-Q1	Automotive 120-V boot, 3-A peak, high frequency, high-side/low-side driver	17	3	20	SO PowerPAD™	✓
UCC27211A-Q1	120-V boot, 4-A peak, high frequency high-side and low-side driver	17	4	20	SO PowerPAD	✓
UCC27321-Q1	Automotive Single 9-A High Speed Low-Side MOSFET Driver With Enable	15	9	25	8MSOP, 8SOIC	✓
UCC27425-Q1	Automotive Dual 4-A High Speed Low-Side MOSFET Driver With Enable	16	4	25	8MSOP, 8SOIC	✓
UCC27511A-Q1	Single-channel high-speed, low-side gate driver with –5-V input voltage handling ability with split output	18	8	13	6SOT-23	✓
UCC27519A-Q1	Single-channel 4-A high-speed, low-side gate driver with non-inverting configuration and CMOS input with –5-V input voltage handling ability	18	4	13	5SOT-23	✓
UCC27524A-Q1	Dual-channel 5-A high-speed, low-side gate driver with negative input voltage capability	18	5	14	8MSOP, 8SOIC	✓
UCC27528-Q1	UCC27528-Q1 dual 5-A high-speed low-side gate driver based on CMOS input	18	5	17	SOIC	✓
UCC27531-Q1	Single-channel 2.5-A/5-A, 35-V max V _{DD} , FET and IGBT gate driver with split output and with 5-V negative input voltage handling ability	35	5	17	6SOT-23	✓
UCC27712-Q1	Automotive 620-V, 1.8-A source, 2.8-A sink, High-Side Low-Side Gate Driver With Interlock	20	2.8	100	8SOIC	✓

*Suggested resale price in U.S. dollars in quantities of 1,000.

New devices are listed in bold red.

High-Voltage Power: AC/DC and Isolated DC/DC Controllers and Converters

The TI portfolio of isolated power-conversion solutions covers the complete end-to-end power-supply building blocks from front-end PFC controllers to PWM controllers. These solutions support the most popular isolated-power topologies, including the advanced phase-shifted full-bridge. The portfolio also includes a variety of MOSFET gate drivers that support both primary and secondary MOSFET-driver

applications, including synchronous-rectifier driver topologies and many other power-supply support products.

Power-Supply Solutions

- PFC controllers:
 - Transition mode or critical conduction mode
 - Continuous-conduction mode
 - Interleaved
 - Bridgeless

- PWM controllers:
 - Single-ended: Flyback, forward, active-clamp
 - Double-ended: Half-bridge, phase-shifted full-bridge, push-pull, LLC hard-switching full-bridge
 - UCD3K digital control solutions

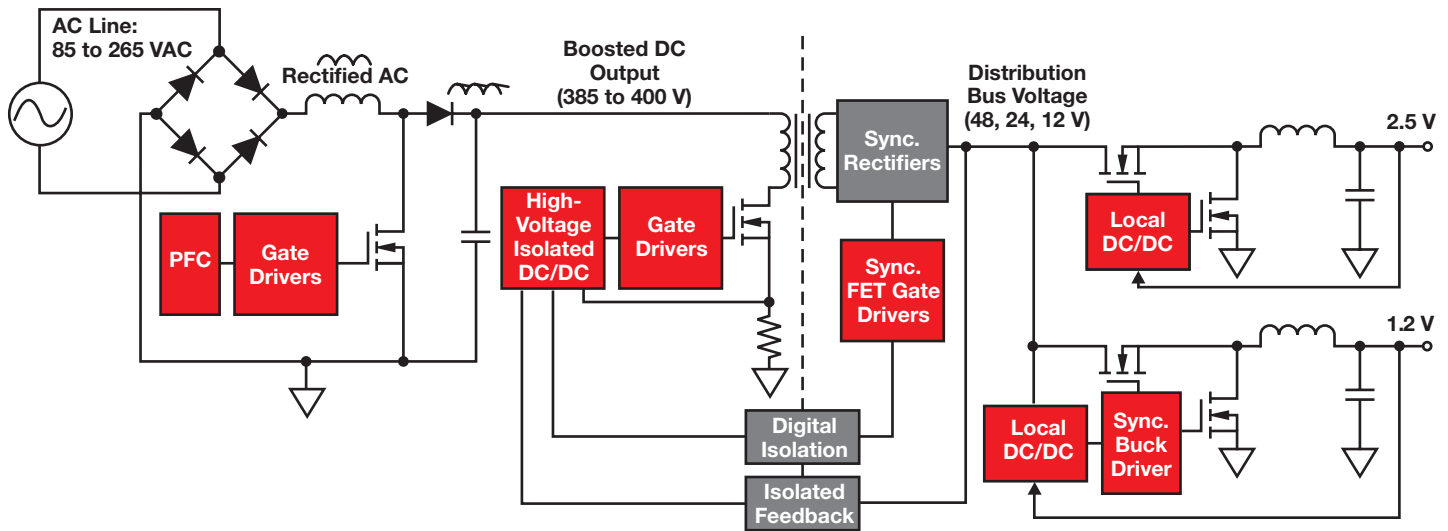

PFC Controllers and PFC + Isolated DC/DC

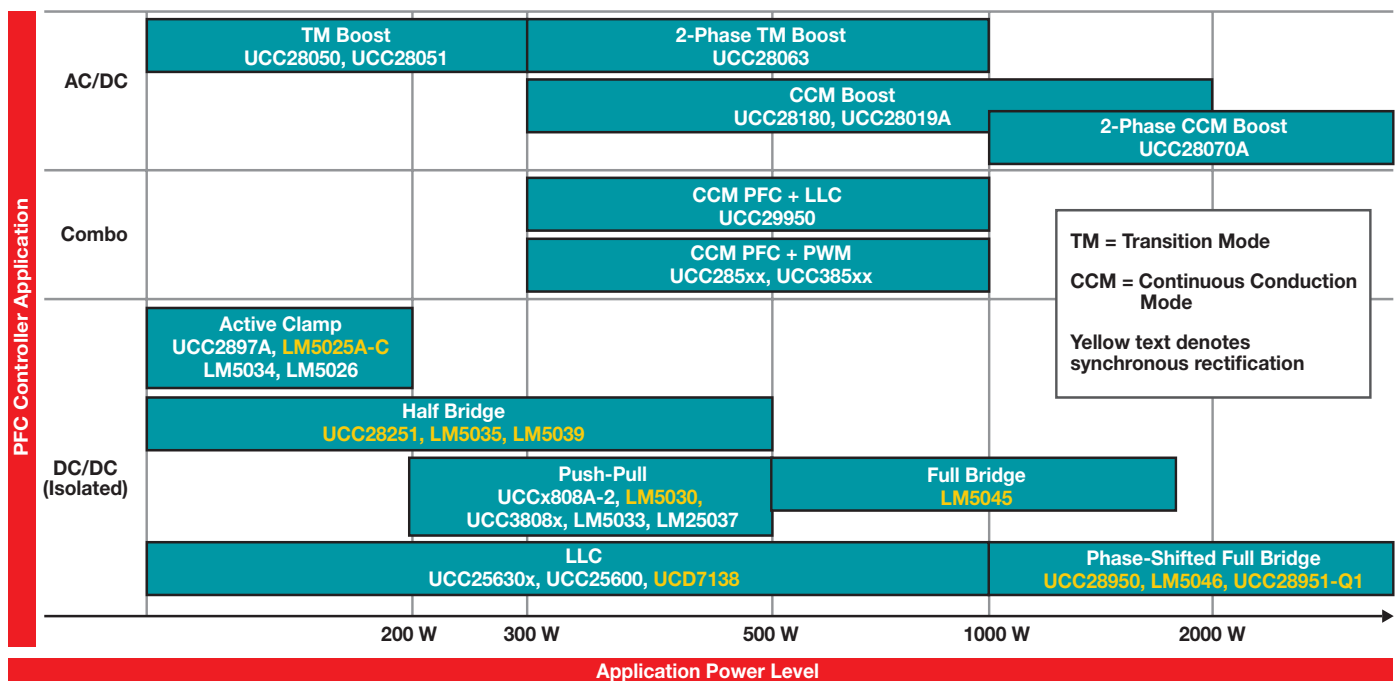

High-Voltage Power: AC/DC and Isolated DC/DC Controllers and Converters

Offline Flyback Controllers (Up to 150 W)

UCC28600/10 LM5021 LM5023 8-Pin Green-Mode Controllers	UCC28740 SSR Flyback with 700-V Startup	UCC28700/1 PSR Flyback	UCC28710/1/2 PSR Flyback with 700-V Startup	UCC28730 PSR Flyback with 700-V Startup and Wakeup	UCC28630/1/2/3/4 High Power PSR Flyback with 700-V Startup, Wakeup, peak power and x-cap discharge	UCC28780 Active Clamp Flyback Controller
Features/Level of Integration 						

Low- to Medium-Power AC/DC and DC/DC PWMs (25 W to 350 W)

General Purpose PWMs for Boost, Buck, Buck- Boost, Active Clamp Forward and Flyback	UC284xA, UC384xA, TL384x I-Mode, PWM Controllers	UCC28C4x/A 8-Pin, Low-Power BiCMOS, I-Mode PWM Controller	UCC2813-1/2/3/4 Low-Power BiCMOS, I-Mode PWM Controllers	UCC2800/1/2/3/4/5 Low-Power BiCMOS, I-Mode PWM Controllers		
Active Clamp Forward	UCC2897A Advanced I-Mode, Active Clamp, HV Start-Up	LM5025 Voltage-Mode, Active Clamp, HV Start-Up	LM5026 I-Mode, Active Clamp, HV Start-Up			
Push-Pull, Half-Bridge, Full-Bridge and LLC	LM5030 100-V Push-Pull Controller	LM25037 Dual-Mode PWM Controller with Alternating Outputs	UCC28251 Half-Bridge Controller with Pre-Bias	UCC38083 Current-Mode Push-Pull PWM with Programmable Slope Compensation	LM5045 Full-Bridge Controller with Integrated Drivers, Pre-Bias, HV Start-Up	UCC25630x Resonant Half-Bridge Controller
Features/Level of Integration 						

Medium- to High-Power AC/DC and DC/DC PWMs (>300 W)

General-Purpose PWMs for Push-Pull, Half- Bridge, and Full-Bridge	TL494 PWM Control Circuit	TL594 PWM Control Circuit	UC3846 Current-Mode PWM Controller	UC3525A/B Regulated Pulse- Width Modulators	
Active-Clamp, Push-Pull and Half-Bridge	LM5034 Dual Interleaved, Active Clamp, HV Start-Up	LM5030 100-V Push-Pull Controller	UCC28251 Half Bridge with Pre-Bias	LM5039 Half-Bridge, HV Start-Up	LM5035 Half-Bridge with Synchronous Rectifier Driver, HV Start-Up
LLC	UCC25630x LLC Resonant Controller with high-voltage Start Up Enabling Low Standby Power		UCC25600 Resonant Half-Bridge Controller		
Full-Bridge and Phase-Shifted Full-Bridge	LM5045 Full-Bridge Controller with Integrated Drivers, HV Start-Up, Pre-Bias	UCC2895 BiCMOS, Advanced Phase Shift, PWM Controller	UCC28950 Green Mode, Phase Shift, Full Bridge with Synchronous Rectification	LM5046 Phase Shift, Full Bridge, Integrated Drivers, HV Start-Up, Pre-Bias	UCC28951-Q1 Phase-Shifted, Full- Bridge Controller for Wide Input Voltage
Features/Level of Integration 					

High-Voltage Power: AC/DC and Isolated DC/DC Controllers and Converters

Automotive Qualified Controllers

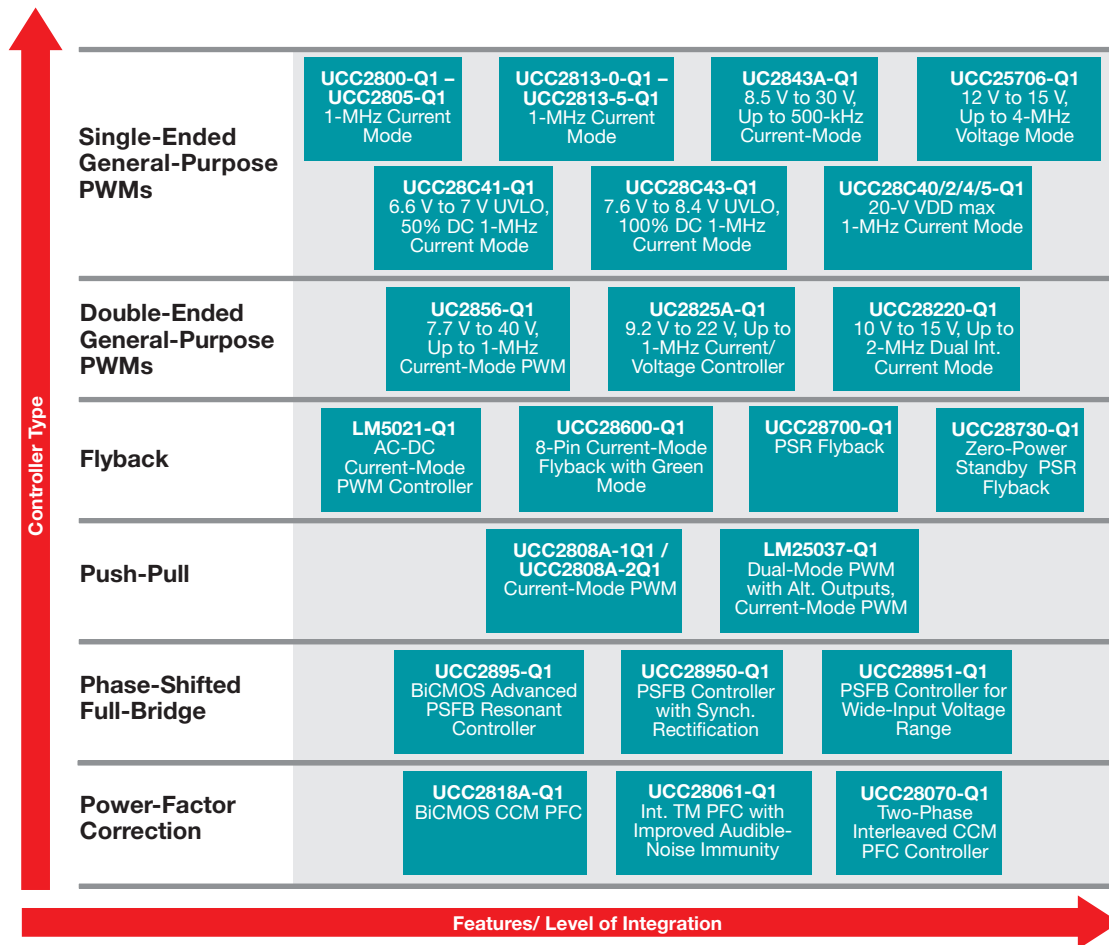

PWM and Resonant Controllers

Device ¹	Typical Power Level (W)	Control Method			Topologies	Maximum Switching Frequency	Supply Voltage (V)	700-V Start-Up Circuit	110-V Start-Up Circuit	Soft Start	Output Drive (Sink/Source) (A)	Package(s)	Automotive Grade	Price*
		Voltage Mode	Current Mode	Avg. Current Mode										
Offline Flyback Controllers														
UCC28710/1/2	Up to 45		✓		PSR Flyback	100 kHz	9 to 35	✓		✓	0.025/0.4	7-SOIC		0.42
UCC28700/1	Up to 45		✓		PSR Flyback	130 kHz	9 to 35			✓	0.025/0.4	6-SOT-26	✓	0.35
UCC28704	Up to 45		✓		PSR Flyback	85 kHz	9 to 35			✓	0.032/0.4	6-SOT-26		0.34
UCC28720	Up to 10		✓		PSR Flyback	80 kHz	9 to 35	✓		✓	0.037/1	7-SOIC		0.40
UCC28722	Up to 10		✓		PSR Flyback	80 kHz	9 to 35			✓	0.037/1	6-SOT-23		0.25
UCC28730	Up to 45		✓		PSR Flyback	83 kHz	9 to 35	✓		✓	0.029/0.4	7-SOIC	✓	0.48
UCC28740	Up to 45		✓		SSR Flyback	100 kHz	9 to 35	✓		✓	0.025/0.4	7-SOIC		0.37
UCC28780	25 to 100		✓		Active Clamp Flyback	1 MHz	11.5 to 34			✓	—	16-SOIC/16-VQFN		0.60
UCC28610	12 to 65		✓		SSR Flyback	133 kHz	9 to 20				—	8-SOIC		0.40
LM5023	Up to 100		✓		SSR QR Flyback	130 kHz	8 to 15			✓	0.3/0.7	8-MSOP		0.38
UCC28630/1/2/3/4	Up to 150		✓		PSR Flyback	120 kHz	8 to 18	✓			1/2	7-SOIC		0.60
UCC28600	Up to 150		✓		SSR QR Flyback	130 kHz	Up to 21			✓	1/0.75	8-SOIC	✓	0.40

¹ Has alternative reduced temperature range versions UC3xxx, UCC3xxx, and SG3xxx.

² Value varies by part number suffix. Please check datasheet.

*Suggested resale price in U.S. dollars in quantities of 1,000.

New devices are listed in bold red.

High-Voltage Power: AC/DC and Isolated DC/DC Controllers and Converters

PWM and Resonant Controllers (Continued)

Device ¹	Typical Power Level (W)	Control Method			Topologies	Maximum Switching Frequency	Supply Voltage (V)	700-V Start-Up Circuit	110-V Start-Up Circuit	Soft Start	Output Drive (Sink/Source) (A)	Package(s)	Automotive Grade	Price*
		Voltage Mode	Current Mode	Avg. Current Mode										
General-Purpose Single-Ended Controllers														
LM5020	10 to 100	✓			Buck, Boost, Flyback (SEPIC, Cuk)	1 MHz	13 to 100	✓	✓		1	10-MSOP/QFN		0.90
LM5021	10 to 100	✓			Flyback (SEPIC, Cuk), Forward (D > 50%)	1 MHz	8 to 30		✓		0.3/0.7	8-MSOP	✓	0.50
LM5022	25 to 100	✓			Buck, Boost, Flyback (SEPIC, Cuk)	2 MHz	6 to 60		✓		1	10-MSOP		1.13
TPS40210	25 to 60	✓			Buck, Boost, Flyback (SEPIC, Cuk)	1 MHz	4.5 to 52		✓		0.5	10-VSSOP		0.75
LM3478	25 to 100	✓			Buck, Boost, Flyback (SEPIC, Cuk)	1 MHz	2.97 to 40		✓		1	8-VSSOP/QFN		0.75
LM3481	25 to 100	✓			Buck, Boost, Flyback (SEPIC, Cuk)	1 MHz	2.97 to 48		✓		1	10-VSSOP		0.80
UCC2800/1/2/3/4/5 ¹	Up to 250	✓	✓		Buck, Boost, Flyback (SEPIC, Cuk), Fwd (Including 2-Switch Fwd), Forward (D > 50%)	1 MHz	Up to 11		✓		1/1	8-TSSOP/SOIC/DIL (PDIP)	✓	1.40
UCC2807-1-2-3 ¹	Up to 250	✓	✓		Buck, Boost, Flyback (SEPIC, Cuk), Forward (D > 50%)	1 MHz	Up to 13.5		✓		1/1	8-SOIC/DIL (PDIP)		1.65
UCC2809-1-2 ¹	Up to 250	✓	✓		Buck, Boost, Flyback (SEPIC, Cuk), Forward (D > 50%)	1 MHz	Up to 19		✓		0.8/0.4	8-MSOP/TSSOP/SOIC/DIL (PDIP)		0.95
UCC2813-0/1/2/3/4/5 ¹	Up to 250	✓	✓		Buck, Boost, Flyback (SEPIC, Cuk), Fwd (Including 2-Switch Fwd) ² , Forward (D > 50%) ²	1 MHz	Up to 11		✓		1/1	8-TSSOP/SOIC/DIL (PDIP)	✓	1.05
UCC3884	50 to 250	✓	✓		Buck, Boost, Flyback (SEPIC, Cuk), Forward (D > 50%)	1 MHz	8.9 to 15		✓		1/0.5	16-SOIC/DIL (PDIP)		1.60
UCC28C40/1/2/3/4/5 ¹	Up to 250	✓	✓		Buck, Boost, Flyback (SEPIC, Cuk), Forward (D > 50%)	1 MHz	Up to 18		✓		1/1	8-MSOP/SOIC/DIL (PDIP)	✓	0.75
TL2842B/3B/4B/5B ¹	Up to 250	✓	✓		Buck, Boost, Flyback (SEPIC, Cuk), Forward (D > 50%)	500 kHz	Up to 30				1/1	8/14-SOIC, 8-DIL (PDIP)		0.38
UC2842A/3A/4A/5A ¹	Up to 250	✓	✓		Buck, Boost, Flyback (SEPIC, Cuk), Forward (D > 50%)	500 kHz	Up to 30				1/1	8/14-SOIC, 8-DIL (PDIP)	✓	0.48
UC28023	50 to 750	✓	✓		Buck, Boost, Flyback (SEPIC, Cuk), Forward (D > 50%)	1 MHz	9 to 30		✓		1.5/1.5	16-SOIC-W/DIL (PDIP)		1.35
UC3823A/B	50 to 750	✓	✓		Buck, Boost, Flyback (SEPIC, Cuk), Forward (D > 50%)	1 MHz	9 to 22		✓		2/2	16-SOIC-W/DIL (PDIP), 20-PLCC		4.90
General Purpose Double-Ended Controllers														
LM25037	50 to 500	✓	✓		Push-Pull, Half-Bridge, Full-Bridge	2 MHz	5.5 to 75		✓		1.2	16-TSSOP	✓	1.41
LM5032	50 to 500	✓	✓		Flyback (SEPIC, Cuk), Fwd (Including 2-Switch Fwd)	1 MHz	13 to 100	✓	✓		2.5/2.5	16-TSSOP		1.40
SG2524 ¹	50 to 500	✓			Buck, Boost, Flyback (SEPIC, Cuk), Fwd (Including 2-Switch Fwd), Forward (D > 50%), Interleaved Fwd/Flyback/Boost, Push-Pull, Half-Bridge, Full-Bridge	722 kHz	8 to 40				0.05/0.05	16-SOIC/DIL (PDIP)		0.33
TL494 or TL594	50 to 500	✓			Buck, Boost, Flyback (SEPIC, Cuk), Fwd (Including 2-Switch Fwd), Forward (D > 50%), Interleaved Fwd/Flyback/Boost, Push-Pull, Half-Bridge, Full-Bridge	300 kHz	7 to 40				0.2/0.2	16-SOIC/DIL (PDIP)		0.17
UC2524A ¹	50 to 500	✓			Push-Pull, Half-Bridge, Full-Bridge	450 kHz	8 to 40		✓		0.2/0.2	16-SOIC/DIL (PDIP)		0.70
UC2525A ¹	50 to 500	✓			Push-Pull, Half-Bridge, Full-Bridge	500 kHz	8 to 35		✓		0.4/0.4	16-SOIC/DIL (PDIP)		0.74
UC2526A ¹	50 to 500	✓			Push-Pull, Half-Bridge, Full-Bridge	600 kHz	8 to 35		✓		0.2/0.2	18-SOIC/DIL (PDIP)		1.20
UC28025	50 to 500	✓	✓		Push-Pull, Half-Bridge, Full-Bridge	1 MHz	8.4 to 30		✓		1.5/1.5	16-SOIC/DIL (PDIP)		1.35
UC2825 ¹	50 to 500	✓	✓		Push-Pull, Half-Bridge, Full-Bridge	1 MHz	9 to 30		✓		1.5/1.5	16-SOIC/DIL (PDIP)		1.84
UC2825A/B ¹	50 to 500	✓	✓		Push-Pull, Half-Bridge, Full-Bridge	1 MHz	9 to 22		✓		2/2	16-SOIC/DIL (PDIP)		3.51
UC2846 ¹	50 to 500	✓	✓		Push-Pull, Half-Bridge, Full-Bridge	500 kHz	8 to 40		✓		0.5/0.5	16-SOIC/DIL (PDIP)		1.66
UC2856 ¹	50 to 500	✓	✓		Push-Pull, Half-Bridge, Full-Bridge	1 MHz	8 to 40		✓		1.5/1.5	16-SOIC/DIL (PDIP)		2.26
UCC2806 ¹	50 to 500	✓	✓		Push-Pull, Half-Bridge, Full-Bridge	1 MHz	7 to 15		✓		0.5/0.5	16-SOIC/SSOP/TSSOP/DIL (PDIP)		5.57
UCC2810 ¹	50 to 500	✓	✓		Buck, Boost, Flyback (SEPIC, Cuk), Fwd (Including 2-Switch Fwd), Interleaved Fwd/Flyback/Boost	1 MHz	8.3 to 11		✓		1/1	16-SOIC/DIL (PDIP)		1.90
UCC28220	50 to 500	✓	✓		Interleaved Fwd/Flyback/Boost	1 MHz/ch.	8 to 15		✓		0.01/0.01	16-TSSOP/SOIC	✓	1.90
UCC28221	50 to 500	✓	✓		Interleaved Fwd/Flyback/Boost	1 MHz/ch.	36 to 110	✓	✓		0.01/0.01	16-SOIC, 20TSSOP		2.40
Push-Pull Controllers														
LM5033	50 to 500	✓			Push-Pull, Half-Bridge, Full-Bridge	1 MHz	15 to 100		✓	✓	1.5/1.5	10-VSSOP/WSON		0.85
LM5030	50 to 500	✓			Push-Pull, Half-Bridge, Full-Bridge	1 MHz	14 to 90		✓	✓	1.5/1.5	10-VSSOP/WSON		0.99
UCC28089	50 to 500	✓			Interleaved Fwd/Flyback/Boost, Push-Pull, Half-Bridge, Full-Bridge	1 MHz	8 to 15		✓		0.5/1.0	8-SOIC		0.91
UC2827-1 ¹	50 to 500	✓			Push-Pull, Half-Bridge, Full-Bridge	500 kHz	8.4 to 20		✓		1.0/0.8	24-SOIC-W/DIL (PDIP), 28-PLCC		3.70
UC2827-2 ¹	50 to 500	✓			Push-Pull, Half-Bridge, Full-Bridge	500 kHz	8.4 to 20		✓		1.0/0.8	24-SOIC-W/DIL (PDIP), 28-PLCC		4.44
UCC2808-1/-2/A-1/A-2	50 to 500	✓			Push-Pull, Half-Bridge, Full-Bridge	1 MHz	4.3 to 15		✓		1.0/0.5	8-TSSOP/SOIC/DIL (PDIP)	✓	1.30
LM5041/A/B	50 to 500	✓	✓		Push-Pull, Half-Bridge, Full-Bridge	1 MHz	15 to 100	✓	✓		1.5/1.5	16-TSSOP/QFN		1.30
UCC28083/4/5/6	50 to 500	✓	✓		Push-Pull, Half-Bridge, Full-Bridge	2 MHz	8.3 - 15		✓		1.0/0.5	8-TSSOP/SOIC/DIL (PDIP)		1.18

¹ Has alternative reduced temperature range versions UC3xxx, UCC3xxx, and SG3xxx.

² Value varies by part number suffix. Please check datasheet.

*Suggested resale price in U.S. dollars in quantities of 1,000.

New devices are listed in bold red.

High-Voltage Power: AC/DC and Isolated DC/DC Controllers and Converters

PWM and Resonant Controllers (Continued)

Device ¹	Typical Power Level (W)	Control Method			Topologies	Maximum Switching Frequency	Supply Voltage (V)	700-V Start-Up Circuit	110-V Start-Up Circuit	Soft Start	Output Drive (Sink/Source) (A)	Package(s)	Automotive Grade	Price*
		Voltage Mode	Current Mode	Avg. Current Mode										
Active-Clamp Forward Controllers														
LM5025/A/B/C	50 to 300	✓			Act-Clamp Fwd/Flyback	1 MHz	8 to 90		✓	✓	3/3	16-TSSOP/QFN		1.08
LM5026	50 to 300		✓		Act-Clamp Fwd/Flyback	1 MHz	8 to 100		✓	✓	3/3	16-TSSOP/QFN		1.25
LM5034	50 to 300		✓		Dual Interleaved Act-Clamp Fwd, Flyback (SEPIC, Cuk), Fwd (Including 2-Switch Fwd)	2 MHz	8 to 100		✓	✓	2.5/2.5	20-TSSOP		1.45
UCC2891 or UCC2893	50 to 300		✓		Act-Clamp Fwd/Flyback	1 MHz	18 to 110		✓	✓	2.5/2.5	16-TSSOP/SOIC		1.28
UCC2892 & UCC2894	50 to 300		✓		Act-Clamp Fwd/Flyback	1 MHz	8.5 to 16			✓	2.5/2.5	16-TSSOP/SOIC		1.28
UCC2897A	50 to 300		✓		Forward (D > 50%), Act-Clamp Fwd/Flyback	1 MHz	18 to 110		✓	✓	2/2	20-TSSOP/QFN		1.20
Half-Bridge and Full-Bridge Controllers														
LM5036	50 to 700	✓			Half-Bridge w/ Bias	1 MHz	18 to 100		✓	✓	2/1.5	28-QFN		2.00
LM5035/B/C	50 to 700	✓			Half-Bridge	2 MHz	13 to 105		✓	✓	2/2	28-TSSOP, 20-HTSSOP, 24-QFN		1.90
LM5039	50 to 700	✓			Half-Bridge	2 MHz	13 to 105		✓	✓	2/2	20-HTSSOP, 24-QFN		1.75
LM5045	50 to 1000	✓	✓		Full-Bridge	2 MHz	14 to 100		✓	✓	1.5/2	28-HTSSOP/QFN		2.00
UCC28250/1	50 to 1000		✓		Push-Pull, Half-Bridge, Full-Bridge	1 MHz	4.3 to 20			✓	0.2/0.2	20-TSSOP/QFN		1.70
Phase-Shifted Full-Bridge Controllers														
LM5046	200 to 1000	✓	✓		Phase-Shifted Full Bridge	2 MHz	14 to 100		✓	✓	1.5/2	28-HTSSOP/QFN		2.45
UCC28951	200 to 6000	✓	✓	✓	Phase-Shifted Full Bridge	1 MHz	9 to 17			✓	0.1/0.1	20-SOIC-W/DIL (PDIP)/PLCC	✓	3.52
UCC28950	200 to 6000	✓	✓	✓	Phase-Shifted Full Bridge	1 MHz	8 to 20			✓	0.2/0.2	24-TSSOP	✓	3.15
UCC2895 ¹	200 to 6000	✓	✓	✓	Phase-Shifted Full Bridge	1 MHz	8 to 20			✓	0.2/0.2	24-TSSOP	✓	3.99
LLC Controllers														
UCC25600	200 to 1000	✓	✓		Resonant LLC, Half-Bridge	350 kHz	11.5 to 18			✓	0.4/0.8	8-SOIC		0.45
UCC256301/2/3/4	200 to 1000	✓	✓		Resonant LLC, Half-Bridge	1 MHz	13 to 26	✓		✓	0.6/1.2	14-SOIC		0.95
Power Factor Correction Controllers														
UCC29950	> 300				CCM Boost LLC and Combo Controller	350 kHz	11 to 18			✓	1.6/1	16-SOIC		0.75
UCC28510 to UCC28517	> 300				CCM PFC + PWM	500 kHz	12 to 17			✓	3/2	20-SOIC/DIL (PDIP)		1.80
UCC28500 to UCC28503 ¹	> 300				CCM PFC + PWM	200 kHz	12 to 17			✓	1.2/1.2	20-SOIC/DIL (PDIP)		3.29
UCC29910A	< 135				Buck PFC	100 kHz	3 to 3.6			✓	0.0015/0.006	14-TSSOP		1.30
UCC28050/1 ¹	< 300				Single Phase Transition Mode (TM) PFC	200 kHz	13.5 to 182				0.75/0.75	8-SOIC/DIL (PDIP)		0.23
UCC28810/1	< 300				Single Phase Transition Mode (TM) PFC	250 kHz	13.5 to 182			✓	0.75/0.75	8-SOIC		0.28
UCC28056	< 300				Single Phase Transition Mode (TM) PFC	600 kHz	8.5 to 34			✓	1/0.7	16-SOIC		0.32
UCC28060/1	< 600				Interleaved Transition Mode (TM) PFC	500 kHz	14 to 21			✓	1.8/1	16-SOIC	✓	1.28
UCC28063/A	< 600				Interleaved Transition Mode (TM) PFC	500 kHz	14 to 21			✓	1.8/1	16-SOIC		0.75
UCC28064	< 600				Interleaved Transition Mode (TM) PFC	500 kHz	14 to 21			✓	1.8/1	16-SOIC		1.30
UCC2853A	< 1000				Single Phase Critical Conduction Mode (CCM) PFC	63 kHz	12 to 40				1/1	8-SOIC		1.20
UCC2817/8/9/A/-1 ¹	< 1000				Single Phase Critical Conduction Mode (CCM) PFC	250 kHz	10 to 17			✓	1.2/1.2	16-SOIC/TSSOP/DIL (PDIP)	✓	1.27
UCC28019A	< 1000				Single Phase Critical Conduction Mode (CCM) PFC	65 kHz	11.5 to 21			✓	2/1.5	8-SOIC/DIL (PDIP)		0.50
UCC28180	< 1000				Single Phase Critical Conduction Mode (CCM) PFC	250 kHz	12.5 to 21			✓	2/1.5	8-SOIC		0.45
UCC28070/A	> 1000				Interleaved Critical Conduction Mode (CCM) PFC	300 kHz	11.2 to 21			✓	0.75/0.75	20-TSSOP/SOIC	✓	1.80
Wide-Input Range Voltage Mode Controllers														
UCC25701/2	25 to 250	✓			Flyback (SEPIC, Cuk), Fwd (Including 2-Switch Fwd), Forward (D > 50%)	700 kHz	8.8 to 15			✓	1.2/1.2	14-TSSOP/SOIC/DIL (PDIP)		3.10
UCC25705/6	25 to 250	✓			Boost, Flyback (SEPIC, Cuk), Fwd (Including 2-Switch Fwd), Forward (D > 50%)	4 MHz	8.0 to 15				0.1/0.1	8-MSOP/SOIC/DIL (PDIP)	✓	0.90
Intermediate Bus Controllers														
UCC28230/1	150 to 500				Half-Bridge, Full-Bridge	2 MHz	-0.3 to 20			✓	0.2/0.2	12-SON, 14-TSSOP		1.20
Secondary-Side, Post Regulation														
LM(2)5115/A	—		✓		Synchronous Secondary-Side Post Regulator	1 MHz	4.5 to 42/75			✓	2/2.5	16-TSSOP/QFN		1.05/1.80

¹Has alternative reduced temperature range versions UC3xxx, UCC3xxx, and SG3xxx.

²Value varies by part number suffix. Please check datasheet.

*Suggested resale price in U.S. dollars in quantities of 1,000.

New devices are listed in bold red.

High-Voltage Power: AC/DC and Isolated DC/DC Controllers and Converters

Offline Converters

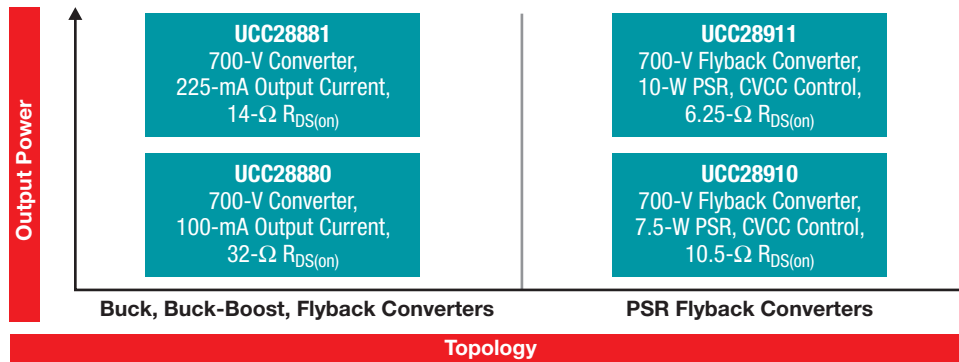

Device	Typical Power Level (W)	Control Method		Topologies	Maximum Switching Frequency	FET Voltage Rating (V)	FET RDS(on) (Ω)	Soft Start	Package(s)	Price*
		Hysteresis	Current Mode							
UCC28880	Up to 3	✓		Buck, Buck-Boost, Flyback	62 kHz	700	32	✓	7-SOIC	0.55
UCC28881	Up to 4.5	✓		Buck, Buck-Boost, Flyback	62 kHz	700	14	✓	7-SOIC	0.62
UCC28910	Up to 7.5		✓	PSR Flyback	115 kHz	700	10.5	✓	7-SOIC	0.58
UCC28911	Up to 10		✓	PSR Flyback	115 kHz	700	6025	✓	7-SOIC	0.60

*Suggested resale price in U.S. dollars in quantities of 1,000.

Synchronous Rectification (SR) Controllers

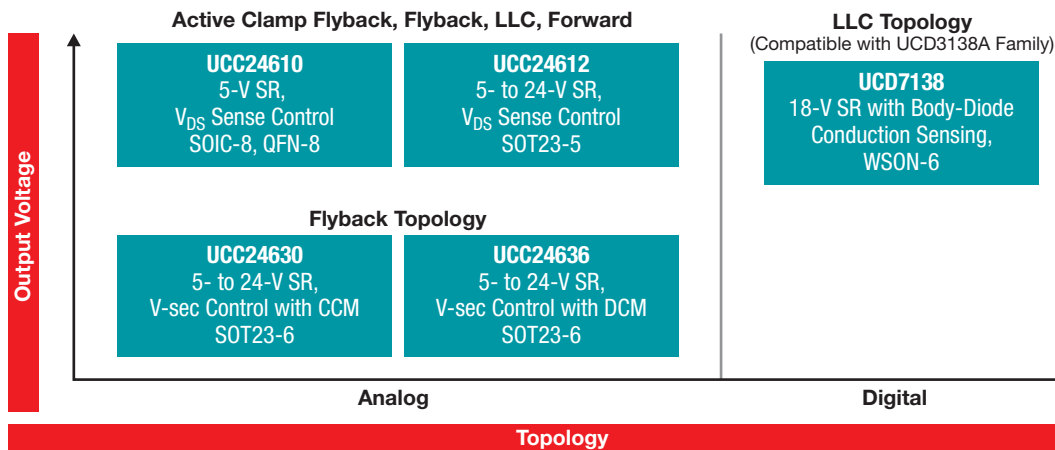

Device	Control Method			Topologies	Maximum Switching Frequency	Maximum V _{DS} (V)	Supply Voltage (V)	Technology	Package(s)	Price*
	V _{DS} Sensing	Volt-Sec Balance	Body Diode Conduction							
UCC24610	✓			CCM/DCM/QR Flyback, Active Clamp Flyback, LLC, Forward	600 kHz	50	4.5 to 5.5	Analog	8-SOIC/8-SON	0.49
UCC24612	✓			CCM/DCM/QR Flyback, Active Clamp Flyback, LLC, Forward	1 MHz	230	4 to 28	Analog	5-SOT-23	0.40
UCC24630		✓		DCM/ CCM Flyback	200 kHz	—	3.75 to 28	Analog	6-SOT-23	0.40
UCC24636		✓		DCM Flyback	130 kHz	—	3.75 to 28	Analog	6-SOT-23	0.40
UCD7138			✓	LLC with UCD3138	2 MHz	45	4.5 to 18	Digital	6-SON	0.75

*Suggested resale price in U.S. dollars in quantities of 1,000.

New devices are listed in **bold red**.

High-Voltage Power: AC/DC and Isolated DC/DC Gallium Nitride (GaN) Solutions

Overview

GaN is not just a dream of the future. The technology is ready to use today.

GaN is enabling designers to achieve new levels of performance and efficiency in power electronics systems. GaN's inherent advantages enable engineers to rethink power density in ways that were not possible before and to meet the world's increasing power demands. These advantages include:

- Low C_G/Q_G gate capacitance/charge (1 nC-Ω vs. 4 nC-Ω for Si): Provides faster turn-on and turn-off, higher switching speed, reduced gate-drive losses
- Low C_{OSS}/Q_{OSS} output capacitance/charge (5 nC-Ω vs. 25 nC-Ω for Si): Provides faster switching, and reduced switching losses
- Low $R_{DS(on)}$ (5 mΩ-cm² vs. >10 mΩ-cm² for Si): Provides lower conduction losses for a given FET size
- Zero Q_{rr} : Reduces hard-switching losses for totem-pole topologies and also reduces ringing on switch node and lowers EMI

These superior device properties of GaN allow faster switching frequencies and slew rates in SMPS applications. These device properties have the indirect effect of shrinking inductors, capacitors, magnetics, and other passive components that often take up the majority of volume in a power supply without compromising its ability to deliver power.

Regardless of the type of GaN used, gate-drive design is critical to achieving the best overall performance. There are several key parameters when designing with GaN:

- Bias voltage: It is important to bias the gate with the optimal voltage to get the best switching performance, while protecting the gate against potential overvoltage conditions.
- Loop inductance: Because of GaN's high slew rate and switching frequency, any parasitic inductance in the design introduces losses and ringing in the system. There are many sources of inductance in a design, including leads and internal bond wires in both the GaN FET and driver packages, as well as printed circuit board (PCB) traces. To limit the ringing and losses, it is important to minimize inductance in the gate and power loops. GaN power-stage solutions, like the LMG3410, minimize these parasitic inductances by integrating the driver into the package and using a low-inductance QFN package.
- Propagation delay: Short propagation delays and good matching are important to minimize deadtimes in high-frequency operation. A propagation delay in the order of 25 ns and matching of 1 to 2 ns is a great starting point for high-frequency (1 MHz or higher) designs.

GaN Power Stage

GaN power stage solutions such as LMG3410 and LMG5200 integrate the driver, GaN FETs and other features in a single package. These solutions not only simplify the circuit design and PCB layout, they also help achieve the highest performance in the system. The LMG3410, for instance, can operate GaN FETs at very high slew rates (>100 V/ns) with minimal ringing on the switch node. This reduces both EMI and voltage stress on the GaN FET.

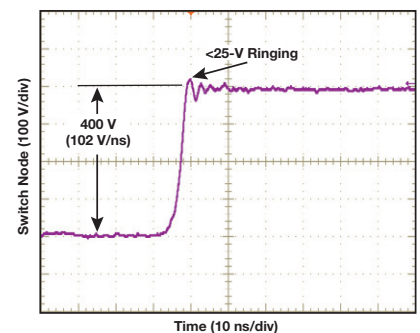

GaN Drivers

TI offers a complete range of GaN FET drivers. These include low-side and half-bridge solutions. The LMG1020 low-side drivers enables fast switching speed with sub-nanosecond pulses in applications such as LiDAR. The LMG1210 is a 50-MHz half-bridge driver that is well suited for many high-speed designs, including DC/DC converters, class-D audio amplifiers, motor drives, and RF-envelope tracking.

TI-GaN Solution has 3x Power Density versus Silicon

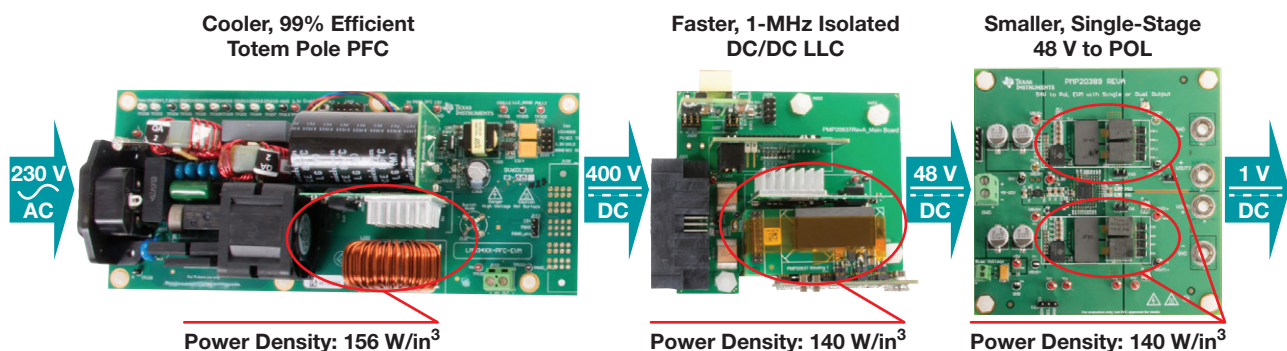

High-Voltage Power: AC/DC and Isolated DC/DC Gallium Nitride (GaN) Solutions

600-V GaN Power Stage

LMG3410

The LMG3410 combines a 600-V, 70-mΩ GaN FET with a smart driver to deliver high power density and an easy-to-design integrated solution. The LMG3410 power stage coupled with TI's analog and digital power-conversion controllers enables designers to create smaller, more efficient and higher-performing designs compared to silicon-based solutions. These benefits are especially important in high-voltage industrial, telecom, enterprise-computing and renewable-energy applications.

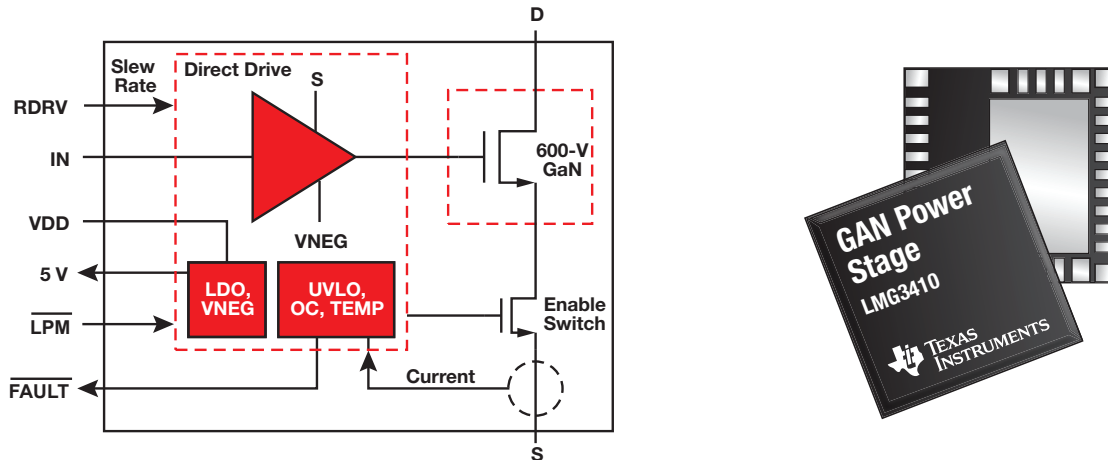

Get more information: www.ti.com/product/LMG3410

80-V GaN Half-Bridge Power Stage

LMG5200

The LMG5200 is a 80-V GaN power stage that integrates an optimized driver and two 18-mΩ GaN FETs in a half-bridge configuration. The GaN half bridge supports hard-switched and resonant switching applications in an easy-to-use 9-pin QFN package. The LMG5200 simplifies board design while minimizing the gate and power-loop inductances. This power stage can be used to design 48-V motor drives with over 98.5% efficiency.

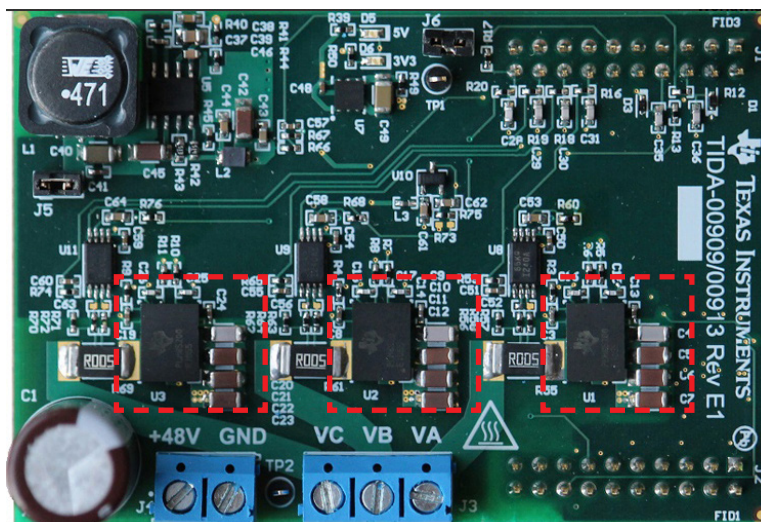

48 V at 10 A with 98.5% efficiency (Board dimensions: 54 x 79 mm).

Get more information: www.ti.com/product/LMG5200

High-Voltage Power: AC/DC and Isolated DC/DC

Gallium Nitride (GaN) Solutions

Low-Side Gate Driver with 60-MHz/1-ns Speed

LMG1020

The LMG1020 device is a single, low-side GaN driver designed for driving GaN FETs and logic-level MOSFETs in high-speed applications. The design simplicity of the LMG1020 minimizes propagation delay to less than 2.5 ns. The LMG1020 is recommended for applications such as LiDAR, time-of-flight laser drivers and Class-E wireless chargers.

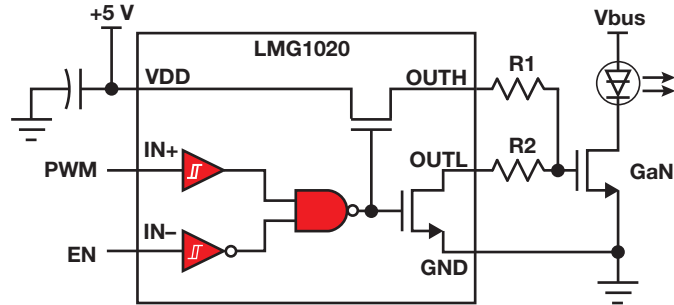

Simplified LiDAR driver-stage diagram.

Get more information: www.ti.com/product/LMG1020

200-V Half-Bridge GaN Driver with Adjustable Dead-Time

LMG1210

The LMG1210 high-performance GaN-FET driver was designed for applications requiring high switching speeds of up to 50 MHz. This driver offers adjustable dead-time control in addition to high efficiency. Applications include high-density DC/DC converters, class-D audio amplifiers, motor drivers, and RF envelope tracking.

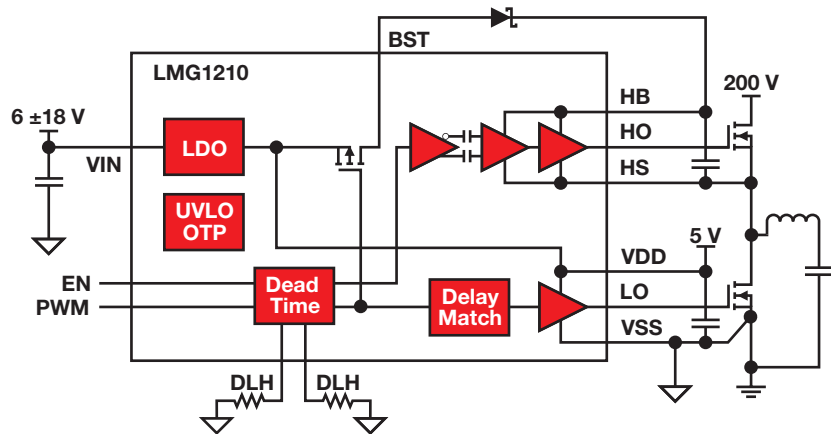

Simplified DC/DC converter.

Get more information: www.ti.com/product/LMG1210

GaN Solutions

Solution	Devices	Type	Part Number
High-Voltage Solutions			
High-Voltage GaN Evaluation Platform	LMG3410	Evaluation Module	LMG3410-HB-EVM, LMG34XX-BB-EVM
500-W LLC (400/12 V)	LMG3410, UCD3138	Reference Design	PMP20289
1-kW CCM Totem-Pole PFC	LMG3410, UCD3138	Reference Design	PMP20873
1-kW LLC (400/48 V)	LMG3410, UCD3138	Reference Design	PMP20637
1.6-kW CRM Totem-Pole PFC	LMG3410, C2000™	Reference Design	TIDA-00961
3-kW Interleaved CCM Totem-Pole PFC	LMG3410, C2000	Reference Design	TIDM-1007
Sub-200-V Solutions			
GaN Power-Stage Evaluation Platform	LMG5200	Evaluation Module	LMG5200EVM-02
48-V to POL DC/DC Converter	LMG5200, TPS53632G	Evaluation Module	LMG5200POLEVM-10
48-V to POL DC/DC Converter	LMG5200, UCD3138	Reference Design	PMP4497
Triple-Rail High-V _{IN} DC/DC Converter	LMG5200, UCD3138	Reference Design	PMP4486
48-V, 3-Phase, 10-A Motor Drive	LMG5200, C2000	Reference Design	TIDA-00909
3-Phase, 200-V AC Servo Drive	LMG3410, C2000	Reference Design	TIDA-00915

Power Management Multi-Channel IC (PMIC) Solutions Selection Guide

TI's portfolio of scalable dual-rail to fully-integrated PMICs harness TI's leading power technology and reduce system complexity with fewer components. Built-in sequencing, monitoring, and voltage scaling help simplify the design versus a fully discrete solution. TI also provides optimized solutions and support for processors, FPGAs, and application-specific subsystems.

Automotive PMICs

www.ti.com/pmic

Processor	Power Management IC	Description	Regulated Outputs (#)	V _{IN} (min) (V)	V _{IN} (max) (V)	Package(s)	Automotive Grade	Configurability
ADAS—Camera and Radar								
Processor Power www.ti.com/powerfpga								
TDA3x	TPS65917-Q1	Automotive 3.15-V to 5.5-V, 5 Buck & 5 LDO Power Management IC (PMIC)	10	3.135	5.25	VQFN	✓	Factory programmable, Software Configurable
TDA2Ex	TPS65917-Q1	Automotive 3.15-V to 5.5-V, 5 Buck & 5 LDO Power Management IC (PMIC)	10	3.135	5.25	VQFN	✓	Factory programmable, Software Configurable
	TPS659039-Q1	Automotive 3.15-V to 5.5-V, 7 Buck & 6 LDO Power Management IC (PMIC) for ARM Cortex™ A15 Processors	14	3.135	5.25	NFBGA	✓	Factory programmable, Software Configurable
AWR12x/14x/16x	LP87524B-Q1	4-A + 2.5-A + Two 1.5-A Buck Converters with Integrated Switches for nanoRadar	4	2.8	5.5	VQFN-HR	✓	User Programmable
Infineon TC2x/3x	TPS653850-Q1	Multirail Power Supply for Microcontrollers in Safety-Relevant Applications	5	2.3	40	HTSSOP	✓	Factory programmable, User programmable
NXP Freescale MPC56/57	TPS653850-Q1	Multirail Power Supply for Microcontrollers in Safety-Relevant Applications	5	2.3	40	HTSSOP	✓	Factory programmable, User programmable
STMicro SPC5	TPS653850-Q1	Multirail Power Supply for Microcontrollers in Safety-Relevant Applications	5	2.3	40	HTSSOP	✓	Factory programmable, User programmable
Renesas RH850	TPS653850-Q1	Multirail Power Supply for Microcontrollers in Safety-Relevant Applications	5	2.3	40	HTSSOP	✓	Factory programmable, User programmable
Subsystem Power								
Camera (Power over Coax)	TPS65000-Q1	2.25-MHz Step-Down Converter with Dual LDOs Power Management IC (PMIC)	3	2.3	6	WQFN	✓	Hardware Configurable, Factory Programmable
Multi-Camera, Radar and LiDAR	TPS65311-Q1	High-Voltage Power-Management IC for Automotive Safety Applications	5	4	40	VQFN	✓	N/A
Sensor Fusion - Safety Island	TPS653850-Q1	Multirail Power Supply for Microcontrollers in Safety-Relevant Applications	5	2.3	40	HTSSOP	✓	Factory programmable, User programmable
Infotainment and Cluster								
Processor Power www.ti.com/powerfpga								
J6 Entry	TPS65917-Q1	Automotive 3.15-V to 5.5-V, 5 Buck & 5 LDO Power Management IC (PMIC)	10	3.135	5.25	VQFN	✓	Factory programmable, Software Configurable
J6 Eco	TPS65917-Q1	Automotive 3.15-V to 5.5-V, 5 Buck & 5 LDO Power Management IC (PMIC)	10	3.135	5.25	VQFN	✓	Factory programmable, Software Configurable
J6	TPS659039-Q1	Automotive 3.15-V to 5.5-V, 7 Buck & 6 LDO Power Management IC (PMIC) for ARM Cortex A15 Processors	14	3.135	5.25	NFBGA	✓	Factory programmable, Software Configurable
	TPS43330A-Q1	Automotive 2-V to 40-V, Low-Iq Single Boost & Dual Synchronous Buck Controller	3	2	40	HTSSOP	✓	N/A
Subsystem Power								
Wide V _{IN} or Direct-to-Battery	TPS65321A-Q1	Automotive 3.6-V to 36-V, 3.2-A Buck Converter with Wide-Vin 280-mA LDO Regulator	2	3.6	36	HTSSOP	✓	Hardware Configurable
	TPS65320D-Q1	Automotive 3.6-V to 36-V, 3.2-A Buck Converter with Auto-Sourced 280-mA LDO Regulator	2	3.6	36	HTSSOP	✓	Hardware Configurable
	TPS43340-Q1	Automotive 4-V to 40-V, Dual Synchronous Buck Controller, 2-A Buck Converter, and 300-mA LDO	4	4	40	HTQFP	✓	N/A
	TPS43350-Q1	Automotive 4-V to 40-V, Low Iq Dual Synchronous Buck Controller	2	4	40	HTSSOP	✓	N/A
Active Safety								
Processor Power www.ti.com/powerfpga								
Infineon TC2x/3x	TPS653850-Q1	Multirail Power Supply for Microcontrollers in Safety-Relevant Applications	5	2.3	40	HTSSOP	✓	Factory programmable, User programmable
NXP Freescale MPC56/57	TPS653850-Q1	Multirail Power Supply for Microcontrollers in Safety-Relevant Applications	5	2.3	40	HTSSOP	✓	Factory programmable, User programmable
STMicro SPC5	TPS653850-Q1	Multirail Power Supply for Microcontrollers in Safety-Relevant Applications	5	2.3	40	HTSSOP	✓	Factory programmable, User programmable
Renesas RH850	TPS653850-Q1	Multirail Power Supply for Microcontrollers in Safety-Relevant Applications	5	2.3	40	HTSSOP	✓	Factory programmable, User programmable
TMS570	TPS65381A-Q1	Multirail Power Supply for Microcontrollers in Safety-Relevant Applications	5	5.8	40	HTSSOP	✓	User Programmable

Power Management Multi-Channel IC (PMIC) Solutions

Selection Guide

Industrial PMICs

www.ti.com/pmic

Processor	Power Management IC	Description	Regulated Outputs (#)	V _{IN} (min) (V)	V _{IN} (max) (V)	Package(s)	Configurability
Smart Meters							
Processor Power www.ti.com/powerfpga							
AM335x	TPS650250	Power Management IC (PMIC) for Li-Ion Powered Systems	6	2.5	6	VQFN	Hardware Configurable
	TPS65910	Integrated Power Management IC (PMIC) w/ 4 DC/DCs, 8 LDOs and RTC in 6x6mm QFN Family	13	1.7	5.5	VQFN	Factory programmable, Software Configurable
I.MX 7	TPS65023	Power Management IC (PMIC) with 3DC/DCs, 3 LDOs, I2C Interface and DVS	6	2.5	6	WQFN	Hardware Configurable, Software Configurable
Building and Factory Automation							
Processor Power www.ti.com/powerfpga							
AM335x	TPS65218D0	Power Management IC (PMIC) for ARM Cortex-A8/A9 SoCs and FPGA	7	2.2	5.5	HTQFP, VQFN	Factory Programmable, User Programmable
	TPS65217	Power Management IC (PMIC) w/ 3 DC/DCs, 4 LDOs, Linear Battery Charger & White LED Driver	9	2.75	5.8	VQFN	Factory programmable, User programmable, Software Configurable
	TPS650250	Power Management IC (PMIC) for Li-Ion Powered Systems	6	2.5	6	VQFN	Hardware Configurable
	TPS65910	Integrated Power Management IC (PMIC) w/ 4 DC/DCs, 8 LDOs and RTC in 6x6mm QFN Family	13	1.7	5.5	VQFN	Factory programmable, Software Configurable
AM437x	TPS65218D0	Power Management IC (PMIC) for ARM Cortex-A8/A9 SoCs and FPGA	7	2.2	5.5	HTQFP, VQFN	Factory Programmable, User Programmable
AM438x	TPS65218D0	Power Management IC (PMIC) for ARM Cortex-A8/A9 SoCs and FPGA	7	2.2	5.5	HTQFP, VQFN	Factory Programmable, User Programmable
AM571x	TPS659037	Power Management IC (PMIC) for ARM Cortex A15 Processors	14	3.135	5.25	NFBGA	Factory programmable, Software Configurable
AM572x	TPS65916	TPS65916 Power Management Unit (PMU) for Processor	10	3.135	5.25	VQFN	Factory programmable, Software Configurable
	TPS659037	Power Management IC (PMIC) for ARM Cortex A15 Processors	14	3.135	5.25	NFBGA	Factory programmable, Software Configurable
AM574x	TPS659037	Power Management IC (PMIC) for ARM Cortex A15 Processors	14	3.135	5.25	NFBGA	Factory programmable, Software Configurable
AM576x	TPS65916	TPS65916 Power Management Unit (PMU) for Processor	10	3.135	5.25	VQFN	Factory programmable, Software Configurable
IMx7	TPS65023	Power Management IC (PMIC) with 3DC/DCs, 3 LDOs, I2C Interface and DVS	6	2.5	6	WQFN	Hardware Configurable, Software Configurable
TMS570	TPS65381A-Q1	Multirail Power Supply for Microcontrollers in Safety-Relevant Applications	5	5.8	40	HTSSOP	User Programmable

Personal Electronics PMICs

www.ti.com/pmic

Processor	Power Management IC	Description	Regulated Outputs (#)	V _{IN} (min) (V)	V _{IN} (max) (V)	Package(s)	Configurability
Phones, PCs and Notebooks, Tablets and ebooks							
Processor Power www.ti.com/powerfpga							
DLP2000	DLPA1000	Power Management and LED Driver IC for DLP2000 Projectors	4	-0.3	7	DSBGA	Factory Programmable
Skylake	TPS650830	Programmable Mid-Input Voltage Range Power Management IC (PMIC) for Skylake Processors	8	5.4	24	NFBGA	Factory programmable, Software Configurable
Apollo lake	TPS650940	Programmable Mid Input Voltage Range Power Management IC (PMIC) for Apollo Lake Processors (LPDDR4)	12	5.6	21	QFN	Factory programmable, Software Configurable
Subsystem Power							
E-Ink	TPS65185	PMIC for E-Ink® Vizplex™ Enabled Electronic Paper Display w/Active Discharge	6	3	5.9	VQFN	Factory Programmable
Image Sensors	TPS68470	Power Management IC (PMIC) with Flash LED Driver and Ref Clock Generation for Compact Camera Module	8	2.97	3.63	DSBGA	Factory Programmable, User Programmable

LED Drivers

Overview and Automotive LED Drivers: Front Lighting

LED Drivers Overview

TI's comprehensive LED driver portfolio includes LED drivers, controllers, and matrix solutions for automotive, personal electronics, and industrial applications. TI enables designers to create energy efficient, high performing, flexible lighting solutions with high-performance devices, tools and design resources to speed your time to market. Visit www.ti.com/led to view all products and www.ti.com/led_training to watch training videos on LED-driver basics, system requirements and overcoming design challenges.

Automotive LED Drivers

Overview

TI's automotive LED driver portfolio delivers integrated LED drivers, controllers, and matrix solutions that enable innovative styling and enhance system reliability in headlight, rear light, convenience lighting, and interior lighting designs. TI's LED products provide a high level of system integration to reduce PCB footprint, improve reliability, and streamline the design process.

Visit www.ti.com/autoled to view all products.

Front Lighting

TI's automotive LED-driver portfolio provides solutions for everything from full-LED ECU-headlamp platforms to simple single-feature headlamps like fog lights or daytime running lights. Our broad portfolio includes buck LED drivers, multi-topology controllers and the LED matrix manager.

Buck LED Drivers

Buck LED drivers provide an ideal current source for the LEDs. TI's automotive LED-driver portfolio include both dual- and single-channel solutions that use hysteretic and quasi-hysteretic

control topologies to handle dynamic LED loads and to enable advanced dimming capabilities.

Multi-Topology LED-Driver Controllers

Multi-topology LED-driver controllers can be configured as a buck-boost LED driver to provide a stable constant-current output for the LEDs regardless of fluctuations in the car's battery voltage in a single power stage or as a boost controller to convert the fluctuating battery voltage into a stable DC input supply in a solution with two power

stages. TI's LED-driver controllers are point-of-load solutions that are highly configurable and modular with advanced dimming capabilities in addition to diagnostic and protection features.

LED Matrix Manager

An LED matrix manager uses integrated bypass switches to shunt current around individual LEDs while dimming to provide pixel-level control of the LEDs to implement dynamic headlight functions like sequential turn-signals and adaptive front lighting. The LED matrix manager also provides comprehensive LED fault detection and protection.

LED Drivers

Automotive LED Drivers: Front Lighting

Automotive Front-Lighting Solutions

Device	Max LED Current (A)	Input Voltage Range (V)	Maximum Output Voltage (V)	Number of Channels	Switching Frequency	Topology	Features	Packaging	Price*
Buck Converter									
TPS92518/HV-Q1	5	6.5 to 42/65	39/62	2	1 kHz to 2 Mhz	Buck	SPI communications interface, PWM and analog dimming, quasi-hysteretic control, high-side current sense	24 HTSSOP	1.20/1.31
TPS92515/515HV-Q1	2	5.5 to 42/65	39/62	1	Adj: 50 kHz to 2 MHz	Buck	Integrated N-channel MOSFET, PWM and analog dimming, constant off-time control, high-side current sense	10 HVSSOP	0.85/0.96
LM3409/09HV-Q1	5	6.0 to 42/75	42/75	1	Adj: 50 kHz to 2 MHz	Buck	PWM and analog dimming, 100% duty cycle achievable, constant off-time control, high-side current sense	10 HVSSOP/14 PDIP	0.55/0.60
LM3406HV-Q1	1.5	6.0 to 75	73	1	Adj: 20 kHz to 1 MHz	Buck	Integrated N-channel MOSFET, PWM and analog dimming, true average output current control	14 HTSSOP	1.05
Multi-Topology Converter									
TPS92692-Q1	5	4.5 to 65	65	1	Prog: 80 kHz to 800 kHz	Boost, Buck-Boost, SEPIC, Buck, Flyback	Spread spectrum, LED current monitoring output (IMON), $\pm 4\%$ LED current accuracy, PWM, analog and analog to PWM dimming, fixed frequency peak current mode control, high-side or low-side current sense	20 HTSSOP	1.00
TPS92691-Q1	5	4.5 to 65	65	1	Prog: 80 kHz to 700 kHz	Boost, Buck-Boost, SEPIC, Buck, Flyback, Cuk	LED current monitoring output (IMON), $\pm 3\%$ LED current accuracy, PWM and analog dimming, fixed frequency peak current mode control, high-side or low-side current sense	16 HTSSOP	0.88
LM3429-Q1	5	4.5 to 75	72	1	Prog: 100 kHz to 1 MHz	Boost, Buck-Boost, SEPIC, Buck, Flyback	PWM and analog dimming, predictive off-time control, high-side current sense	14 HTSSOP	1.11
LM3424-Q1	5	4.5 to 75	72	1	Prog: 25 kHz to 1 MHz	Boost, Buck-Boost, SEPIC, Buck, Flyback	PWM and analog dimming, peak current mode control, high-side current sense	20 HTSSOP	1.34
LM3423-Q1	5	4.5 to 75	72	1	Prog: 100 kHz to 1 MHz	Boost, Buck-Boost, SEPIC, Buck, Flyback	PWM and analog dimming, predictive off time control, high-side current sense	20 HTSSOP	1.29
LM3421-Q1	5	4.5 to 75	72	1	Prog: 100 kHz to 1 MHz	Boost, Buck-Boost, SEPIC, Buck, Flyback	PWM and analog dimming, predictive off time control, high-side sense	16 HTSSOP	1.17
LED Matrix Manager									
TPS92662-Q1	1.25	4.5 to 60	62V	12	—	Switch	UART serial communications interface, crystal oscillator, I ² C interface, 10-bit PWM dimming, LED open/short detection and protection	48 HTQFP	2.00
TPS92661-Q1	2	4.5 to 5.5	60V	12	—	Switch	UART serial communications interface, 10-bit PWM dimming, LED open/short detection and protection	48 HTQFP	4.21

*Suggested resale price in U.S. dollars in quantities of 1,000.

LED Drivers

Automotive LED Drivers: Rear Lighting

Integrated solutions with full diagnostic and thermal management features

TI's portfolio of linear LED drivers consists of reliable, low-EMI solutions for rear stop, turn and backup lighting. The portfolio offers a full range of devices with full diagnostics (e.g., LED open, short and single-LED short) and thermal

management features as well as different output-channel counts and output-current capabilities. The TPS92830-Q1 automotive LED controller is able to support higher power and greater system thermal performance simultaneously by

removing the integrated MOSFET used in traditional LED drivers. TI's family of single-channel TPS9261x-Q1 LED drivers provides much more flexibility for engineers designing an array of different applications for exterior lighting.

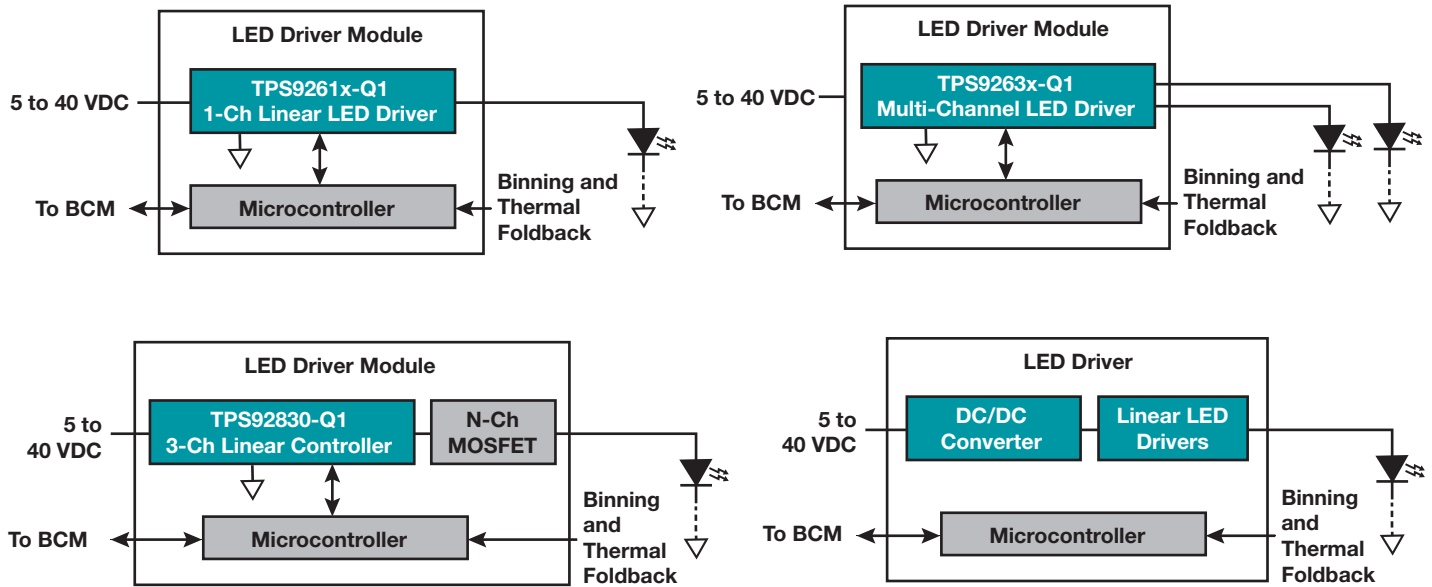

Rear-Lighting LED Drivers

Device	No. of Channels	FET Integrated	V _{IN} (V)	Output Current per Channel (mA)	Output Current Accuracy (%)	Diagnostics and Protections	Package
TPS92830-Q1	3	No	4.5 to 40	Decided by ext. FET	2.5	Open, Short, Output current derating	TSSOP-28
TPS92610-Q1	1	Yes	4.5 to 40	450	4.5	Open, Short, Single LED short, Thermal shutdown	HTSSOP-14
TPS92611-Q1	1	Yes	4.5 to 40	300	4.5	Open, Short, Thermal shutdown	MSOP-8
TPS92612-Q1	1	Yes	4.5 to 40	150	4.5	Short protection, Thermal shutdown	SOT23-5
TPS92630-Q1	3	Yes	4.5 to 40	150	1.5	Open, Short, Single LED short, Thermal foldback	HTSSOP-16
TPS92638-Q1	8	Yes	4.5 to 40	70	3	Open, Short, Thermal foldback	HTSSOP-20

LED Drivers

Automotive LED Drivers: Other Signal and Convenience Lighting

Flexible and Easy-to-Use LED Solutions

LEDs are now widely used outside of the traditional exterior lighting applications. These LEDs enhance the driver's experience with additional safety-enhancing and stylistic lighting options. TI's new TPS9261x-Q1 family of single-channel linear-LED drivers enables more styling possibilities for signal- and convenience-lighting applications, such as the ones

outlined in the diagram below. Higher current accuracy, fewer system components, and more system protection have become the most critical design considerations for automotive design engineers. TI's TPS9261x-Q1 LED-driver family offers differentiated output capabilities, packages, and diagnostic features, allowing design engineers to

simplify their system by replacing many discrete components that would typically be used to achieve the same functionality. To learn more about TI's automotive LED driver portfolio, visit www.ti.com/autoled



Applications for TPS9261x-Q1 family of single-channel linear-LED drivers

LED Drivers

Automotive LED Drivers: Multi-Channel Indicator

A complete portfolio to provide solutions for automotive LED-indicator applications

Many applications in a car implement multiple LEDs to indicate necessary and useful information to drivers and passengers. For example, there are clusters, HVAC control panels, faceplates,

shift-by-wire and so on. LEDs in such applications typically need more features than exterior lighting applications like RGB LED drivers, such as color mixing, better control of output current on each

channel, more complicated diagnostic features, etc. TI provides a complete portfolio to support all requirements to help customers achieve expected system performance.

Multi-Channel Indicator LED Drivers

Device	Topology	No. of Channels	Breakdown Voltage (V)	Output Current per Channel (mA)	Current-Control Features	Diagnostics and Protections	Package
TPIC6C596	Shift Register	8	33	100	—	—	TSSOP-16, SOIC-16, PDIP-16
TPIC2810	Shift Register	8	40	100	—	—	SOIC-16
TLC6C598-Q1	Shift Register	8	40	50	—	—	TSSOP-16, SOIC-16
TLC6C5912-Q1	Shift Register	12	40	50	—	—	TSSOP-20, SOIC-20
TLC6C5816-Q1	Shift Register	16	40	50	PWM	Configurable	HTSSOP-28
TLC6C5724-Q1	Constant Current	24	7	50	PWM, DC, BC	Open, Short, Short to GND, Channel off diagnostic, Adjacent pin short	HTSSOP-38
TLC6C5716-Q1	Constant Current	16	7	50	PWM, DC, BC	Open, Short, Short to GND, Channel off diagnostic, Adjacent pin short	HTSSOP-38
TLC6C5712-Q1	Constant Current	12	7	75	PWM, DC	Open, Short, Short to GND, Channel off diagnostic, Adjacent pin short	HTSSOP-28
TLC5941-Q1	Constant Current	16	17	90	PWM, DC	Open	HTSSOP-28
TLC5926-Q1	Constant Current	16	17	120	PWM, DC	Open, Individual channel OTP	HTSSOP-24
TLC5927-Q1	Constant Current	16	17	120	PWM, DC	Open, Short, Individual channel OTP	HTSSOP-24
TLC5916-Q1	Constant Current	8	17	120	PWM, DC	Open, Individual channel OTP	SOIC-16
TLC5917-Q1	Constant Current	8	17	120	PWM, DC	Open, Short, Individual channel OTP	SOIC-16
TLC59116-Q1	Constant Current	16	17	120	PWM, DC	Open, Individual channel OTP	TSSOP-28

LED Drivers

RGB- and White-LED Drivers

Overview

TI's RGB- and white-LED solutions focus on delivering indication, programmable LED blinking rates and edges, autonomous LED control, and LED power for

today's growing application space for LEDs. Whether you need a multichannel device to control multiple LEDs independently or RGB color and sequencing effects, TI has a solution for you.

RGB and white LEDs can enhance the end user experience through simple color notification or pattern animation in personal electronics, home automation and wearable products.

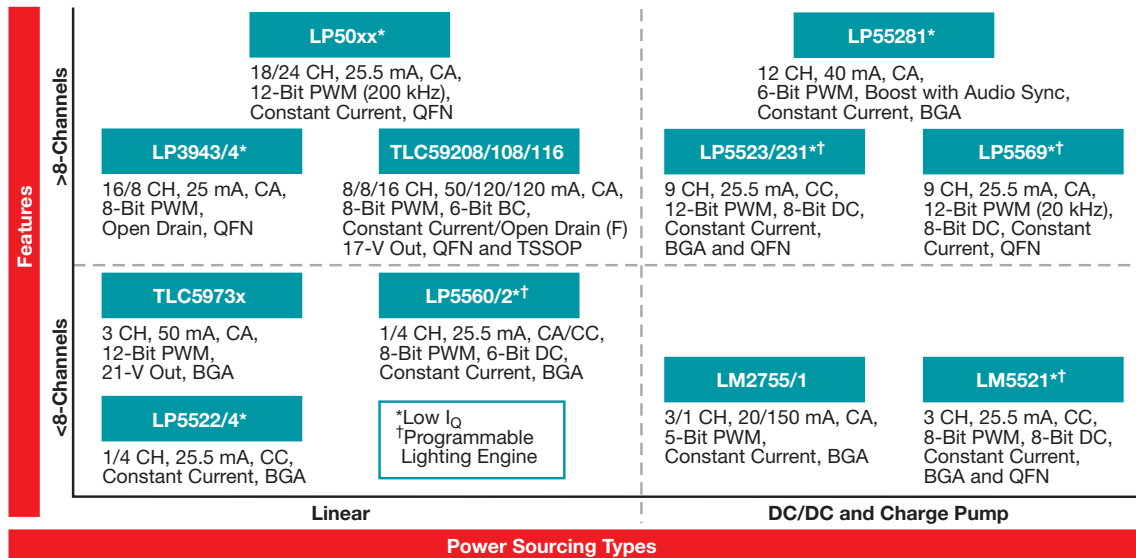

RGB- and White-LED Drivers

Device	V _{IN} (V)	V _{OUT} (V)	Type	Number of Channels	Number of LEDs	LED Configuration	Current Regulation	I _{OUT} (max) (A)	Programmable Lighting Engine	Dimming ¹	Package	Price*
LP5560	2.7 to 5.5	2.7 to 5.5	Linear	1	1	Single	✓	0.0195		Single-Wire	DSBGA (4)	0.28
LP5520	2.9 to 5.5	5 to 20	Boost	3	18	Parallel, Series	✓	0.18		SPI or I ² C	DSBGA (25)	1.65
LP5522	2.7 to 5.5	2.7 to 5.5	Linear	1	1	Single	✓	0.02		Single-Wire	DSBGA (6)	0.40
TLC5973	3 to 5.5		Linear	3	3	Parallel, Series	✓	0.15		Single-Wire	SOIC (8)	0.32
TLC59731	3 to 5.5		Linear	3	3	Parallel, Series	✓	0.15		Single-Wire	SOIC (8)	0.30
LM2755	2.7 to 5.5	3 to 5.5	Charge Pump	3	3	Parallel	✓	0.09		I ² C	DSBGA (18)	0.51
LP5521	2.7 to 5.5	2.7 to 5.5	Charge Pump	3	3	Parallel	✓	0.0765	✓	I ² C	DSBGA (20)/WQFN (24)	0.40/0.60
LP5562	2.7 to 5.5	2.7 to 5.5	Linear	4	4	Parallel	✓	0.11	✓	I ² C	DSBGA (12)	0.38
LP5524	2.7 to 5.5	2.7 to 5.5	Linear	4	4	Parallel	✓	0.1		Direct PWM	DSBGA (9)	0.29
LP3950	3 to 4.5	4.1 to 5.3	Boost	6	6	Parallel		0.15		SPI or I ² C	TLGA (32)	2.03
LP3952	2.7 to 5.5	4 to 5.3	Boost	6	6	Parallel	✓	0.5		I ² C	DSBGA (36)	1.16
TLC5960	10 to 28	0 to 34	Linear	8		Parallel, Series				Direct PWM	TSSOP (38)	1.10
TLC6C598	3 to 5.5		Linear	8		Parallel		0.4		Serial	TSSOP (16)	0.31
TLC59108	3 to 5.5		Linear	8		Parallel, Series	✓	0.96		I ² C	TSSOP (20)/VQFN (20)	0.75
TLC59108F	3 to 5.5		Linear	8		Parallel, Series		0.96		I ² C	TSSOP (20)/VQFN (20)	0.75
TLC59208F	3 to 5.5		Linear	8		Parallel, Series		0.4		I ² C	TSSOP (16)/VQFN (16)	0.65
LP3944	2.3 to 5.5		Linear	8	8	Parallel		0.2		I ² C	WQFN (24)	0.70
LP5523	2.7 to 5.5	2.7 to 5.5	Charge Pump	9	9	Parallel	✓	0.23	✓	I ² C	DSBGA (25)	0.70
LP55231	2.7 to 5.5	2.7 to 5.5	Charge Pump	9	9	Parallel	✓	0.23	✓	I ² C	WQFN (24)	0.75
LP5569	2.5 to 5.5	2.5 to 5.5	Charge Pump	9	9	Parallel	✓	0.23	✓	I ² C	WQFN (24)	0.68
LP8501	2.5 to 5.5	2.5 to 5.5	Charge Pump	9	9	Parallel	✓	0.23	✓	I ² C	DSBGA (25)	0.75
LP55281	2.7 to 5.5	4 to 5.3	Boost	12	13	Parallel	✓	0.4		SPI or I ² C	DSBGA (36)	0.90
TLC6C5912	3 to 5.5		Linear	12		Parallel		0.6		Serial	TSSOP (20)	0.45
LP3954	2.7 to 5.5	4 to 5.3	Boost	12	13	Parallel	✓	0.4		SPI or I ² C	DSBGA (36)	2.27
TLC59116	3 to 5.5		Linear	16		Parallel, Series	✓	1.92		I ² C	TSSOP (28)/VQFN (32)	1.00
TLC59116F	3 to 5.5		Linear	16		Parallel, Series	✓	1.92		I ² C	TSSOP (28)/VQFN (32)	1.00
LP3943	2.3 to 5.5		Linear	16	16	Parallel		0.4		I ² C	WQFN (24)	0.84
LP5018	2.7 to 5.5		Linear	18	18	Parallel	✓	0.63		I ² C	VQFN (32)	0.73
LP5024	2.7 to 5.5		Linear	24	24	Parallel	✓	0.84		I ² C	VQFN (32)	0.82

¹May be via ENABLE pin, CONTROL pin or analog feedback network.

*Suggested resale price in U.S. dollars in quantities of 1,000.

LED Drivers

Signage LED Display Drivers

The LED display is becoming popular in variety of applications including outdoor displays, indoor displays like cinema screens, and micro-LED displays for portable electronics.

TI's complete portfolio of LED display drivers offers a wide array of solutions with differentiated features to support any application:

- The TLC592x family of LED display drivers uses simple on/off control for flexible system design with high-power image processors.
- The TLC594x and TLC595x LED display driver families use an integrated PWM generator for higher control intelligence and reduced controller power.
- The TLC5958x LED display driver family integrates the PWM controller and SRAM to support high multiplexing and achieve even higher display performance and system integration.

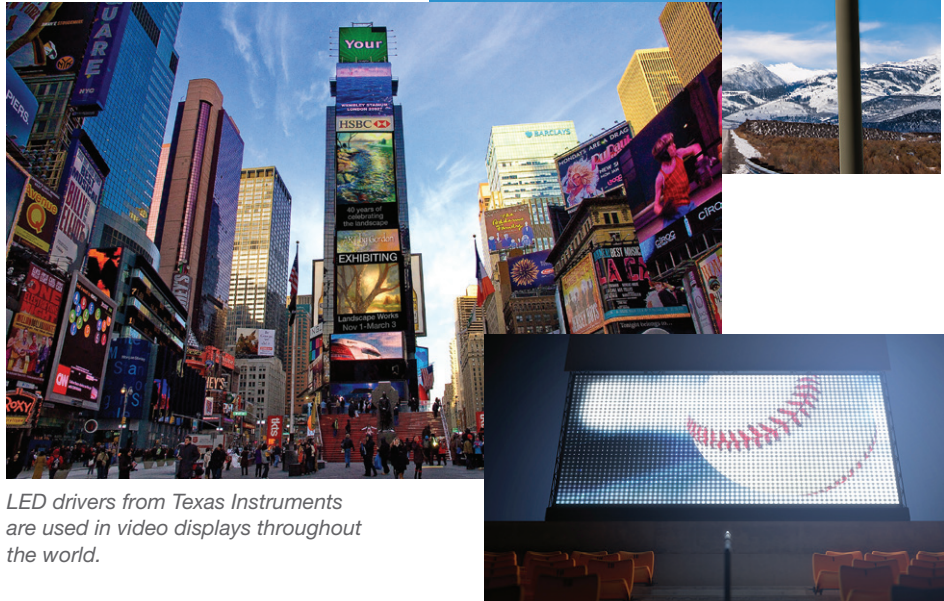

LED drivers from Texas Instruments are used in video displays throughout the world.

Get more information: www.ti.com/signage

Signage LED Display Drivers

Device	No. of Chan.	V _{IN} Min (V)	V _{IN} Max (V)	Output Current I _{LED} (mA)	Channel-to-Channel Accuracy (%)	Dev.-to-Dev. Accuracy (%)	Recharged FET	Short Detection	Open Detection	Overtemperature Detection	Brightness Control (Bits)	Dot Correction (Bits)	PWM Grayscale Control (Bits)	Interface	Comments	Price*
TLC59210	8	3	5.5	200	—	—								Parallel	Clear function and clock pin for data latch	0.60
TLC5921	16	4.5	5.5	80	±1	±4 (max)		✓	✓					SPI		1.25
TLC5922	16	3	5.5	80	±1	±4			✓	✓		7		SPI		1.35
TLC5923	16	3	5.5	80	±1	±4			✓	✓		7		SPI		1.40
TLC5924	16	3	5.5	80	±1	±4	✓	✓	✓			7		SPI		1.50
TLC5925	16	3	5	45	±4 (max)	±6 (max)				✓				SPI		0.50
TLC59281	16	3	5.5	35	±1	±1								SPI		0.43
TLC59283	16	3	5.5	45	±1.4	±2	✓							SPI	4-channel grouped delay	0.55
TLC5929	16	3	5.5	50	±1	±2		✓	✓	✓	7			SPI	Full protection/monitor for remote-controlled systems	0.85
TLC59401	16	3	5.5	120 ¹ /80 ²	±1	+2/-2.7			✓	✓		6	12	SPI		1.20
TLC5941	16	3	5.5	80	±1	+2/-2.7			✓	✓		6	12	SPI		0.95
TLC5946	16	3	5.5	40	±1	±2			✓	✓		6	12	SPI	4-channel grouped delay, LED open auto-off	0.95
TLC5947	24	3	5.5	30	±2	±2				✓			12	SPI	30-V V _{LED} , internal oscillator	1.95
TLC5948A	16	3	5.5	60 ¹ /45 ²	±0.6	±1	✓	✓	✓		7	7	16E/C ³	SPI	Full protection/monitor for remote-controlled systems	1.30
TLC5949	16	3	3.6	45	±0.6	±1	✓	✓	✓		7		12E/C ³	SPI	Full protection/monitor for remote-controlled systems	1.25
TLC5951	24	3	5.5	40	±1.5	±3	✓	✓	✓		8	7	12, 10, 8	SPI	For 8 RGB LED lamps	1.55
TLC5954	48	3	3.6	34.9	±1	±2		✓	✓		MC 3, BC 7 ⁴			SPI	Ref removal; power save mode	2.40
TLC5955	48	3	5.5	31.9	±2	±2		✓	✓		MC 3, BC 7 ⁴	7	16	SPI	Rref removal; Low knee voltage	2.85
TLC59581	48	3	5.5	25	±1	±1	✓	✓	✓		BC 3, CC 9 ⁴		16	SPI	Integrated SRAM; LGSE	4.50

¹Output current with V_{CC} > 3.6 V.

²Output current with V_{CC} ≤ 3.6 V.

³16E = 16-bit enhanced-spectrum PWM. 16E/C or 12E/C = 16-bit or 12-bit enhanced-spectrum or conventional PWM selectable.

⁴MC = Maximum current control, BC = Global brightness control, CC = Group color brightness control.

*Suggested resale price in U.S. dollars in quantities of 1,000.

LED Drivers

General-Lighting LED Drivers

TI delivers the industry's broadest portfolio of general-lighting LED drivers that are well suited to address all design challenges associated with LED

lighting—high performance with long LED life and passing EMI requirements. Our comprehensive industrial lighting IC portfolio covers a broad range of LED

drivers, including DC/DC, AC/DC and AC/Linear solutions with advanced dimming capabilities and high power-conversion efficiency.

General-Lighting LED Drivers

Device	Max LED Current (A)	Input Voltage Range (V)	Max Output Voltage (V)	Number of Channels	Switching Frequency	Topology	Features	Packaging	Price*
DC/DC High-Brightness LED Drivers									
TPS92513/513HV	1.5	4.5 to 42/60	40/58	1	Prog: 100 kHz to 2 MHz	Buck	Current mode control, PWM and analog dimming, frequency synchronization	10 HVSSOP	0.28/0.34
TPS92512/512HV	2.5	4.5 to 42/60	40/58	1	Prog: 100 kHz to 2 MHz	Buck	Current mode control, PWM and analog dimming, frequency synchronization	10 HVSSOP	0.46/0.50
TPS92511	0.5	4.5 to 65	65	1	Prog: 50 kHz to 500 kHz	Buck	Pulse level modulation, no external current sense resistor and no loop compensation, PWM dimming, analog dimming and thermal foldback supported	8 HSOP	0.44
TPS92660	5	8.6 to 80	78	2	Prog: 50 kHz to 1 MHz	Buck + Linear	2-string LED driver with I2C/EEPROM current trim for high CRI lighting, PWM dimming	20 HTSSOP	1.48
TPS92560	2	6.5 to 42	42	1	Adj: 50kHz to 1.5 MHz	Boost, SEPIC	Integrated active low-side input rectifiers, no external loop compensation, compatible with electronic transformers	10 HVSSOP	0.34
TPS92640/41	5	7 to 85	83	1	Prog: 50kHz to 1 MHz	Buck	Synchronous buck controller, PWM and analog dimming, wide dimming range up to 20000:1 with shunt FET PWM dimming (641 only)	14/16 TSSOP	1.25/1.36
LM3463	1.5	12 to 95	95	6	—	Linear	6 output channels, dynamic headroom control, PWM and analog dimming	48 WQFN	2.67
LM3464/64A	1.5	12 to 80/95	80/95	4	—	Linear	4 output channels, dynamic headroom control, PWM and analog dimming	28 HTSSOP	2.27/2.41
LM3466	1.5	6 to 70	70	1	—	Linear	LED string current equalization	8 HSOP / 7 TO-220	0.57
TPS92510	1.5	3.5 to 60	58	1	Prog: 100 kHz to 2.5 MHz	Buck	Thermal foldback, PWM dimming, frequency synchronization	10 HVSSOP	0.74
LM3414/14HV	1	4.5 to 42/65	42/65	1	Prog: 250 kHz to 1 MHz	Floating Buck	Pulse level modulation, no external current sense resistor and no loop compensation, PWM dimming, analog dimming and thermal foldback supported	8 HSOP/WSOP	0.67/0.75
LM3405/05A	1	3 to 15/22	13.5/20	1	1.6 MHz	Buck	Internally compensated current-mode control, PWM dimming	6 SOT/8 VSSOP	0.37/0.40
LM3401	4	4.5 to 35	33	1	Adj: 100 kHz to 1.5 MHz	Buck	PWM dimming, 100% duty cycle capable, no external loop compensation, low-side current sense	8 VSSOP	0.46
LM3404/04HV	1	6.0 to 42/75	40/73	1	Adj: 20 kHz to 1 MHz	Buck	Fast PWM dimming, no loop compensation, supports ceramic capacitor and capacitor-less outputs	8 SOIC/HSOP	0.74/0.81
LM3402/02HV	0.5	6.0 to 42/75	40/73	1	Adj: 20 kHz to 1 MHz	Buck	Fast PWM dimming, no loop compensation, supports ceramic capacitor and capacitor-less outputs	8 VSSOP/HSOP	0.71/0.76

*Suggested resale price in U.S. dollars in quantities of 1,000.

LED Drivers

General-Lighting LED Drivers

General-Lighting LED Drivers (Continued)

Device	Bias Supply		LED Voltage (max) (V)	Switching Frequency	DC/DC or AC/DC Control	Isolated Applications	Non-Isolated Applications	Topology	LED Configuration	Dimming	PFC	EVM	Package(s)	Price*
	V _{CC} (min) (V)	V _{CC} (max) (V)												
AC/DC High-Brightness LED Drivers														
TPS92410	9.5	450	Configurable	—	AC/DC		✓	Linear	Series	TRIAC, TE, Analog	✓	✓	13 SOIC	0.65
TPS92411	7.5	100	Configurable	—	AC/DC		✓	Switch	Series	TRIAC, TE	✓	✓	5 SOT23, 8 HSOP	0.23
TPS92561	6.5	42	Configurable	Adj: 50 kHz to 500 kHz	AC/DC		✓	Boost	Series	TRIAC, TE	✓	✓	8 HVSSOP	0.50
TPS92074	11	18	Configurable	Adj: 50 kHz to 300 kHz	AC/DC		✓	Buck	Series	External	✓		6 SOT, 8 SOIC	0.35
TPS92075	11	18	Configurable	Adj: 50 kHz to 300 kHz	AC/DC		✓	Buck	Series	TRIAC, TE	✓	✓	6 SOT, 8 SOIC	0.40
LM3447	7.5	17.5	Configurable	68 kHz	AC/DC	✓	✓	Flyback/ Buck-Boost	Series	TRIAC, TE, Analog	✓	✓	14 TSSOP	0.50
TPS92023	11.5	18	Configurable	Adj: 40 kHz to 380 kHz	DC/DC	✓	✓	Resonant Half-Bridge	Multi-String	—			8 SOIC	0.65
TPS92315	9	35	Configurable	Adj: 1 kHz to 130 kHz	AC/DC	✓	✓	Flyback	Series	External		✓	6 SOT23	0.35
TPS92560	6.5	42	Configurable	Adj: 50 kHz to 500 kHz	AC/DC, DC/DC		✓	Boost	Series	External	✓	✓	10 HVSSOP	0.72
TPS92314/14A	13	35	Configurable	Adj: 60 kHz to 150 kHz	AC/DC	✓	✓	Flyback/Buck	Series	External	✓	✓	8 SOIC	0.40
TPS92310	13	36	Configurable	Adj: 60 kHz to 150 kHz	AC/DC	✓	✓	Flyback/Buck	Series	External	✓	✓	10 VSSOP	0.40
LM3450/50A	8.5	20	Configurable	Adj: 60 kHz to 120 kHz	AC/DC	✓	✓	Flyback/Boost	Series	TRIAC, TE	✓	✓	16 TSSOP	1.00
TPS92210	9	20	Configurable	Adj: 26 kHz to 140 kHz	AC/DC	✓	✓	Flyback	Series	TRIAC	✓	✓	8 SOIC	0.60
LM3444	8	13	Configurable	Adj: 30 kHz to 300 kHz	AC/DC	✓	✓	Flyback/Buck/Boost/ Buck-Boost	Series	External	✓	✓	10 VSSOP, 8 SOIC	0.35
LM3445	8	12	Configurable	Adj: 30 kHz to 300 kHz	AC/DC	✓	✓	Flyback/Buck/Boost/ Buck-Boost	Series	TRIAC, TE	✓	✓	10 VSSOP, 14 SOIC	0.40

*Suggested resale price in U.S. dollars in quantities of 1,000.

LED Drivers

Flash LED Drivers

Flash LED Drivers

Series or Parallel LED Configuration—

Drives the driver topology. Inductive boost converters provide the necessary high voltage to a series LED string. This requires only one current regulation loop and two connection points for the LED string.

Charge pumps typically drive parallel LEDs; but unless each LED is current-regulated, each leg requires a current-set resistor.

Current Regulation — Avoids brightness variations in LED strings or legs that consist of LEDs with different forward voltages (V_f).

Overvoltage Protection (OVP) —

Protects the inductive driver from destruction in case faulty LEDs open the LED string.

Dimming — LED drivers typically feature analog and/or digital dimming to adjust the LED brightness.

Flash LED Drivers

Device ¹	V _{IN} (V)	Max. Number of LEDs	IR Mode	I _{OUT} (max) (mA)	Typical Switch Current (mA)	Super-Capacitor Support	Down Mode when V _{IN} > V _{OUT}	Control Interface	LED Temperature Monitoring	Power Save Mode	Battery Voltage-Droop Monitoring	Package(s)	Features and Differentiators	Total Solution Size (mm ²)	Price*
LM36010	2.5 to 5.5	1	✓	1500	2800		✓	I ² C	✓		✓	DSBGA-8	4-MHz synchronous boost with ultra-small solution size	7	0.30
LM36011	2.5 to 5.5	1	✓	1500	—		✓	I ² C	✓		✓	DSBGA-8	Inductorless high-current LED driver with strobe and torch modes	4	0.30
LM3643	2.5 to 5.5	2	✓	1500	2800		✓	I ² C	✓	✓	✓	WCSP-12	Independent current control, 12-mA current steps, 358-mA torch current	18	0.40
LM3644	2.5 to 5.5	2	✓	2500	2800		✓	I ² C	✓	✓	✓	WCSP-12	Independent current control, 12-mA current steps, 358-mA torch current	18	0.40
LM3644TT	2.5 to 5.5	2	✓	2500	2800		✓	I ² C	✓	✓	✓	WCSP-12	Independent current control, 12-mA current steps, 500-mA torch current	18	0.40
LM3648	2.5 to 5.5	1	✓	1500	2800		✓	I ² C	✓	✓	✓	WCSP-12	IVFM, Temp Monitoring, 12-mA current steps, 357-mA torch current	18	0.38
LM3648TT	2.5 to 5.5	1	✓	1500	2800		✓	I ² C	✓	✓	✓	WCSP-12	IVFM, Temp Monitoring, 12-mA current steps, 500-mA torch current, 1.6-s timeout	18	0.38
TPS61050	2.5 to 5.5	1		1200	2000			I ² C				QFN-10, WCSP-12	Voltage-mode selection pin	25	0.45
TPS61310	2.5 to 5.5	3		1500	—		✓	I ² C	✓	✓	✓	WCSP-20	HW-reset input, dual-wire camera-module interface, Power Good	25	0.55
TPS61325	2.5 to 5.5	3		4100	—	✓	✓	I ² C	✓	✓		WCSP-20	Dual-wire camera-module interface, super-capacitor balancing, flash ready output	25	0.85
TPS61300	2.5 to 5.5	3		4100	1850	✓	✓	I ² C	✓	✓		WCSP-20	Voltage-mode selection pin (TPS61300/1) DC light-mode selection pin (TPS61300) Flash ready output, HW-reset input (TPS61301/5)	25	1.70
LM3561	2.5 to 5.5	1		600	1000/1500		✓	I ² C	✓			WCSP-12	600-mA compact solution with integrated protection features	15	0.55
LM3554	2.5 to 5.5	2		1200	1000/1500/2000/2500		✓	I ² C	✓		✓	WCSP-16	1.2-A inductive driver with protection features and voltage mode	23	0.46
LM3555	2.5 to 5.5	2		500	1250/1500/1750/2000			I ² C	✓			WCSP-12	Series driver with 90% efficiency and indicator LED	31	0.35
LM3556	2.5 to 5.5	1		1500	1700/1900/2500/3100		✓	I ² C	✓		✓	WCSP-16	4-MHz LED driver with tiny solution size and integrated protection features	18	0.50
LM3559	2.5 to 5.5	2		1800	1400/2100/2700/3200		✓	I ² C	✓		✓	WCSP-16	1.8-A inductive flash LED driver with programmable indicator blinking	26	0.55
LM3560	2.5 to 5.5	2		2000	1600/2300/3000/3600		✓	I ² C	✓			WCSP-16	1.8-A inductive flash LED driver with programmable indicator blinking	26	0.80
LM3550	2.5 to 5.5	4		5000	—	✓		I ² C				LLP	Super-cap flash LED driver with optimal mode to limit power dissipation	—	0.70
LM3642	2.5 to 5.5	1		1500	1700/1900		✓	I ² C	✓		✓	WCSP-9	4-MHz LED driver with tiny solution size and integrated protection features	18	0.35
LM3646	2.5 to 5.5	1		1500	1000/3100		✓	I ² C	✓		✓	WCSP-20	4-MHz LED driver with tiny solution size and integrated protection features	22	0.45
LM3565	2.5 to 5.5	1		930	2300/2600/2900/3300		✓	I ² C	✓		✓	WCSP-16	4-MHz dual series LED driver with tiny solution size and integrated protection features	26	0.44

¹All of these devices have TX-Mask and safety timer DC/Flash.

*Suggested resale price in U.S. dollars in quantities of 1,000.

Display Power and Backlighting

Overview and LCD/OLED Display Power and Drivers

Overview

TI's display power and backlighting portfolio includes display power supplies, backlighting, level shifters, and gamma buffers. TI's high-performance devices enable the highest efficiency at lowest power losses while minimizing solution real estate and achieving best picture quality in a wide variety of applications for personal electronics, automotive and industrial. TI also provides a selection of technical content that includes application notes, reference designs, whitepapers and training videos. Visit www.ti.com/display to view all products and www.ti.com/display_training to watch training videos on display basics, system requirements and overcoming design challenges.

LCD/OLED Display Power and Drivers

Integrated Solutions for Large-Size LCDs (TV, digital kiosk)

Device	V _{IN} (V)	Boost I _{Limit} (min) (A)	Buck I _{Limit} (min) (A)	Features ¹						Price*
				Isolation Switch	V _{GH}	V _{GL}	GVS/GPM	V _{COM}	Other	
TPS65160/A	12	2.8	2	External	Driver	Driver	—	—		1.84
TPS65161	12	2.8	2.5	External	Driver	Driver	—	—		1.12
TPS65161B	12	3.7	2.5	External	Driver	Driver	—	—		1.84
TPS65162	12	2.8	2.8	Integrated	Driver	Driver	Yes	2 op amps		2.21
TPS65168	12	3.5	2.6	Integrated	Controller	Controller	—	—	I ² C programmable, additional bucks for V _{CORE} and HVDD, V _{GH} temp. compensation, reset generator	1.71
TPS65170	12	2.8	1.5	External	Controller	Controller	—	—	Reset generator	1.05
TPS65176	12	3.5	2.5	External	Controller	Controller	—	—		1.15
TPS65178	12	3.5	2.6	Integrated	Controller	Controller	—	P-VCOM	I ² C programmable, additional bucks for HVDD, V _{CORE} and VEPI, V _{GH} temp. compensation, 6-ch gamma buffer	1.71
TPS65177A	12	4.25	2.8	Integrated	Controller	Controller	Yes	—	I ² C programmable, additional bucks for V _{CORE} and HVDD, V _{GH} temp. compensation	1.33
TPS65175/C	12	3.5	2.6	Integrated	Controller	Controller	Yes	P-VCOM, 1 op amp	I ² C programmable, additional buck for HVDD, V _{GH} temp. compensation, 6-ch gamma buffer, reset generator, 12-ch level shifter	1.60

¹V_{GH} = Positive gate driver supply voltage, V_{GL} = Negative gate driver supply voltage, GVS = Gate-voltage shaping for V_{GH}, GPM = Gate pulse modulation, V_{COM} = LCD common voltage reference.

*Suggested resale price in U.S. dollars in quantities of 1,000.

Integrated Solutions for Medium-Size LCDs (Monitor, notebook, tablet, HMI, MMI, CID, cluster)

Device	V _{IN} (V)	Boost I _{Limit} (min) (A)	Features ¹								Automotive Grade	Price*
			Overvoltage Protection	Isolation Switch	V _{Logic}	V _{GH}	V _{GL}	GVS/GPM	V _{COM}	Other		
TPS65100	2.7 to 5.8	1.6	Yes	—	Yes	Yes	Yes	—	1 buffer			1.20
TPS65100-Q1	2.7 to 5.8	1.6	Yes	—	Yes	Yes	Yes	—	1 buffer		✓	1.40
TPS65140	2.7 to 5.8	1.6	Yes	—	Yes	Yes	Yes	—	—	PG generator		1.36
TPS65140-Q1	2.7 to 5.8	1.6	Yes	—	Yes	Yes	Yes	—	—	PG generator	✓	1.58
TPS65142	2.3 to 6	1.8	Yes	—	—	Yes	Yes	Yes	1 buffer	/XAO generator, 6-channel backlight driver integrated		1.30
TPS65145	2.7 to 5.8	0.96	Yes	—	Yes	Yes	Yes	—	—	PG generator		1.26
TPS65145-Q1	2.7 to 5.8	0.96	Yes	—	Yes	Yes	Yes	—	—	PG generator	✓	1.48
TPS65146	2.5 to 6	2	Yes	—	Yes	Yes	Yes	Yes	1 buffer	/XAO generator, LCD discharge		1.30
TPS65148	2.5 to 6	4	Yes	External	—	Yes	Yes	Yes	1 buffer	/XAO generator, additional LDO for external gamma buffer		1.36
TPS65149	3 to 6	4.0	Yes	External	Yes	Yes	—	—	P-VCOM	V _{GH} temp. compensation, /RST generator, /XAO generator 10-channel level shifter		1.52
TPS65150	1.8 to 6	2	Yes	External	—	Yes	Yes	Yes	1 buffer			1.00
TPS65150-Q1	1.8 to 6	2	Yes	External	—	Yes	Yes	Yes	1 buffer		✓	1.53
TPS65165	2.5 to 6	4.4	Yes	—	—	Yes	Yes	Yes	2 op amps, 1 buffer			1.80
TPS65642/A	2.6 to 6	2.5	Yes	Integrated	Yes	Yes	Yes	Yes	P-VCOM, 2 op amps	I ² C programmable, additional buck for V _{IO1} , additional LDO for V _{IO2} , V _{GH} temp. compensation, /RST generator, /XAO generator, 14-ch 10-bit gamma buffer		1.60
TPS65154	2 to 5.5	2.4	Yes	Integrated	Yes	Yes	Yes	Yes	P-VCOM, 1 op amp	I ² C programmable, /RST generator, /XAO generator, 6-channel backlight driver integrated		1.60

¹V_{GH} = Positive gate driver supply voltage, V_{GL} = Negative gate driver supply voltage, GVS = Gate-voltage shaping for V_{GH}, GPM = Gate pulse modulation, V_{COM} = LCD common voltage reference.

*Suggested resale price in U.S. dollars in quantities of 1,000.

Display Power and Backlighting

LCD/OLED Display Power and Drivers

Integrated Solutions for Small-Size LCDs and AMOLEDs (Smartphone, tablet, HMI, wearable, MMI)

Device	Display	V _{IN} (min) (V)	V _{IN} (max) (V)	AV _{DD} (max) (V)	Isolation Switch	V _{Logic1} (min) (V)	V _{GH} ¹ (I _{GH})	V _{GL} ¹ (I _{GL})	Other	Package	Automotive Grade	Price*
TPS65120	Small-form-factor LCD unipolar	2.5	5.5	5.6	Internal	Fixed 3.3	Integrated 20 V max. (6 mA)	Inverter -18 V max. (6 mA)	—	QFN-16		1.10
TPS65130	OLED, CCD sensor, LCD bipolar	2.7	5.5	-15/15	External	—	Boost 15 V max. (0.7 A I-Limit)	Inverter -15 V max. (0.7 A I-Limit)	—	QFN-24		1.10
TPS65131/Q1	OLED, CCD sensor, LCD bipolar	2.7	5.5	-15/15	External	—	Boost 15 V max. (1.8 A I-Limit)	Inverter -15 V max. (1.8 A I-Limit)	—	QFN-24	✓	1.20/1.40
TPS65631W	AMOLED	2.9	4.5	—	Internal	—	Boost fixed 4.6 V (300 mA)	Inverter -1.4 down to -4.4 V max. (250 mA)	0.5% V _{pos} accuracy	QFN-10		0.95
TPS65632	AMOLED	2.9	4.5	7.7	Internal	—	Boost fixed 4.6 V (300 mA)	Inverter -1.5 down to -5.4 V max. (300 mA)	0.5% V _{pos} accuracy, fixed AVDD of 7.7 V	QFN-16		0.85
TPS65135	SFF/MFF, LCD bipolar	2.5	5.5	-7/6	Internal	—	—	—	80-mA output	QFN-16		0.90
TPS65132	SFF/MFF, LCD bipolar	2.5	5.5	—	Internal	—	—	—	150-mA output, single inductor	CSP-15, QFN-20		0.45

¹V_{GH} = Positive gate driver supply voltage, V_{GL} = Negative gate driver supply voltage.

Contact factory for panel-specific AMOLED solutions not shown above at display_contact@list.ti.com

*Suggested resale price in U.S. dollars in quantities of 1,000.

LCD Support IC Solutions (Scan Drivers/Level Shifters)

Device	Description	Number of Channels			V _{GH1} ¹ (max) (V)	V _{GH2} ¹ (max) (V)	V _{GL} ¹ (max) (V)	V _{COM} ¹	GVS/GPM ¹	Charge Sharing	Other	Package	Price*
		Clock	Discharge	Additional									
TPS65192	10-channel level shifter for LCD displays	6	1	3	38	38	-13	—	✓		QFN-28	1.19	
TPS65194	13-channel level shifter for LCD displays	6	1	6	38	38	-15	—	✓	Integrated state machine	QFN-24	0.80	
TPS65193	5-channel level shifter (dual-channel scan driver) for LCD displays	2 pairs	—	1	35	—	-28	—		✓	QFN-24	0.80	
TPS65196	15-channel level shifter for LCD displays	8	1	6	38	38	-23	—	✓	Integrated state machine, soft-start	QFN-28	1.50	
TPS65198	13-channel level shifter for LCD displays	6	1	6	38	38	-23	1 op amp	✓	Integrated state machine	QFN-28	1.00	
TPS65197	10-channel level shifter for LCD displays	6	2	2	45	—	-20	—		✓	QFN-28	1.00	
TPS65680	18-channel pattern-programmable, universal level shifter with OCP for GOA/GIP displays	12	—	6	40	—	-18	—	✓	✓	Simple 2-wire interface to TCON	QFN-32	1.70

¹V_{GH} = Positive gate driver supply voltage, V_{GL} = Negative gate driver supply voltage, GVS = Gate-voltage shaping for V_{GH}.

GPM = Gate pulse modulation, V_{COM} = LCD common voltage reference.

*Suggested resale price in U.S. dollars in quantities of 1,000.

Solutions for E-Readers

Device ¹	V _{IN} (V)	LDO 1	LDO 2	Charge Pump 1	Charge Pump 2	Application	Communication Interface	V _{COM} Adjust	Active Discharge	P2P with TPS65181/2	Package	Price*
TPS65185	3 to 6	15 V, 120 mA	-15 V, 120 mA	22 V, 10 mA	-20 V, 12 mA	Power supply for Active Matrix E Ink® Vizplex® panels	i ² C	User programmable (internal)	Yes	No	QFN-48 (0.5 mm 7x7 or 0.4 mm 6x6)	1.75
TPS65186	3 to 6	15 V, 120 mA	-15 V, 120 mA	22 V, 10 mA	-20 V, 12 mA	Power Supply for Active Matrix E Ink Vizplex panels	i ² C	User programmable (internal)	No	Yes	QFN-48 (0.5 mm 7x7)	1.75

¹See datasheets for more specifications.

*Suggested resale price in U.S. dollars in quantities of 1,000.

Gamma and V_{COM} Buffers

Device	Gamma Channels	V _{COM} Channels	Automotive Grade	Package	Memory	Price*
BUF12800	12	0		24 TSSOP		2.05
BUF16821	16	2		28 TSSOP	✓	2.15
BUF16821-Q1	16	2	✓	28 TSSOP	✓	2.54
BUF20800	18	2		38 TSSOP		2.95
BUF20800-Q1	18	2	✓	38 TSSOP		3.48

*Suggested resale price in U.S. dollars in quantities of 1,000.

Device	Gamma Channels	V _{COM} Channels	Automotive Grade	Package	Memory	Price*
BUF22821	22 (+2)	2		38 TSSOP	✓	3.25
BUF08821	8	1		20 TSSOP		1.90
BUF08630	8	1		20 QFN		2.00
LM8342	0	1		10 SON	✓	0.66

*Suggested resale price in U.S. dollars in quantities of 1,000.

Display Power and Backlighting

LED Backlighting

Backlight WLED Drivers

Device	V _{IN} (V)	Synchronous	Type	V _{OUT} Mode	LED Configuration	Switch Current Limit (typ) (mA)	Output Overvoltage Protection (min) (V)	Load-Disconnect During Shutdown	Dimming Control	Quiescent Current (typ) (mA)	Shutdown Current (typ) (µA)	Package(s)	Notes	Automotive Grade	Price*
TPS61041	1.8 to 6		Inductive		Series	250	28		PWM	0.028	0.1	SOT-23		✓	0.60
TPS61040	1.8 to 6		Inductive		Series	400	28		PWM	0.028	0.1	SOT-23		✓	0.60
TPS61043	1.8 to 6		Inductive		Series	400	17	✓	PWM	0.038	0.1	QFN-8			0.60
TPS61042	1.8 to 6		Inductive		Series	500	27.5	✓	PWM	0.038	0.1	QFN-8			0.60
TPS61045	1.8 to 6		Inductive	✓	Series	375	28	✓	PWM	0.040	0.1	QFN-8			0.65
TPS61046	1.6 to 5.5		Inductive	✓	—	900	28	✓	PWM	0.1	0.1	WCSP-6			0.70
TPS61140	2.5 to 6	✓	Inductive	✓	2 Series	1000	28		PWM	2	1.5	QFN-10			1.00
TPS61150A	2.5 to 6	✓	Inductive		2 Series	1000	28		PWM	2	1.9	QFN-10	Two independently controlled channels		1.00
TPS61166	2.5 to 6	✓	Inductive		Series	1100	19	✓	PWM	1.5	1	QFN-10			1.35
TPS61160	2.7 to 18		Inductive		Series	700	26		PWM/1-Wire	1.8	1	QFN-6			0.72
TPS61161	2.7 to 18		Inductive		Series	700	38		PWM/1-Wire	1.8	1	QFN-6		✓	0.76
TPS61165	3 to 18		Inductive		Series	1200	38		PWM/1-Wire	2.3	1	QFN-6/SOT-23		✓	1.10
TPS61169	2.7 to 5.5		Inductive		Series	1800	36		PWM	.3	1	SC70			0.32
TPS61060	2.7 to 6	✓	Inductive		Series	400	14		PWM	<1	1	QFN-8/WCSP-8			0.70
TPS61061	2.7 to 6	✓	Inductive		Series	400	18		PWM	<1	1	QFN-8/WCSP-8			0.70
TPS61062	2.7 to 6	✓	Inductive		Series	400	22		PWM	<1	1	QFN-8/WCSP-8			0.70
TPS61163A	2.7 to 6.5		Inductive		Series	1500	38	✓	PWM/1-Wire	1.2	1	WCSP-9	2 regulated current sinks		0.50
TPS61183	4.5 to 24		Inductive		6 Channels	2000	38		PWM	4	11	QFN-20	6 regulated current sinks		1.85
TPS61185	4.2 to 24		Inductive		8 Channels	2000	38	✓	PWM	<3	<10	QFN-24	8 regulated current sinks		1.80
TPS61193	4.5 to 40		Inductive		3P12S	1800	45	✓	PWM	5	4.5	HTSSOP-20	3 regulated current sinks	✓	1.00
TPS61194	4.5 to 40		Inductive		4P12S	1800	45	✓	PWM	5	4.5	HTSSOP-20	4 regulated current sinks	✓	1.00
TPS61195	4.5 to 21		Inductive		8 Channels	3500	50	✓	PWM/I ² C	<3	<10	QFN-28	8 regulated current sinks		1.95
TPS61176	2.7 to 6.5		Inductive		6 Channels	1000	38	✓	PWM	<3	<4	QFN-16	Hybrid dimming output current		1.10
TPS61199	8 to 30		Inductive		8 Channels	—	100	✓	PWM	<1.5	<10	SOP-20/HTSSOP-20	Boost controller + 8 current sinks		1.85
LP8543	4.5 to 22		Inductive		7P10S	2500	V _{BOOST} + 1.6 V		PWM/I ² C/ALS	<3.5, Boost ON	—	QFN-24	7 current sinks		2.30
TPS61196	8 to 30		Inductive		6 Channels	—	>100	✓	PWM	<1.5	<15	HTSSOP-28	Boost controller + 6 independently controlled channels		1.85
LP8545	4.5 to 22		Inductive		6P10S	2500	V _{BOOST} + 1.6 V		PWM/I ² C	<4, Boost ON	—	QFN-24			0.99
LP8550	4.5 to 22		Inductive		6P10S	2500	V _{BOOST} + 1.6 V		PWM/I ² C	<3, Boost ON	—	micro SMD-25			0.82
LP8553	4.5 to 22		Inductive		4P10S	2500	V _{BOOST} + 1.6 V		PWM/I ² C	<3, Boost ON	—	micro SMD-25			0.82
LP8556	2.7 to 20		Inductive		6P10S	2600	V _{BOOST} + 1.6 V		PWM/I ² C	2.2	—	micro SMD-25/ QFN-24	6 current sinks + hybrid LED dimming		0.95
LP8557	2.7 to 5.5		Inductive		6P7S	2400	V _{BOOST} + 1.6 V		PWM/I ² C	2.2	—	WCSP-16	6 current sinks + hybrid LED dimming		0.82
LP8860	3 to 40		Inductive		6P12S	9000	48		PWM/I ² C	2.5	1	HLQFP-32		✓	1.45
LP8861	4.5 to 40		Inductive		4P12S	1800	45		PWM	5	4.5	HTSSOP-20		✓	1.00
LP8862	4.5 to 40		Inductive		2P12S	1800	45		PWM	5	4.5	HTSSOP-20		✓	1.00
LP8863	3 to 42		Inductive		6P16S	External FET	48	✓	PWM, I ² C	15	2	HTSSOP 38		✓	1.30
LM3528	2.5 to 5.5		Inductive	✓	2P6S	770	19.25	✓	PWM/I ² C	0.25	1.8	WCSP-12	Independently controlled LED channels		1.00
LM3530	2.7 to 5.5		Inductive		10 Series	839	40	✓	PWM/I ² C	1.35	1	WCSP-12			0.47
LM3532	2.7 to 5.5		Inductive		3P10S	1000	40	✓	PWM/I ² C	1.35	1	WCSP-16	Independently controlled LED channels		0.45
LM3535	2.7 to 5.5		Charge pump		8P	—	—	✓	PWM/I ² C/ALS	1.1	1.7	WCSP-20			0.65
LM3537	2.7 to 5.5		Charge pump		8P	—	—	✓	I ² C	1.1	0.2	WCSP-30			0.85
LM3538	2.7 to 5.5		Charge pump		8P	—	—	✓	I ² C	1.1	0.2	WCSP-30			0.80
LM36272	2.5 to 5		Inductive		2P8S	1800	27	✓	PWM/I ² C	5	2.8	WCSP-24	Includes LCD Bias supply		1.20
LM36273	2.5 to 5		Inductive		3P8S	1800	27	✓	PWM/I ² C	5	2.8	WCSP-24	Includes LCD Bias supply		1.20
LM36274	2.5 to 5		Inductive		4P8S	1800	27	✓	PWM/I ² C	5	2.8	WCSP-24	Includes LCD Bias supply		1.20
LM3630A	2.7 to 5.5		Inductive		2P10S	1200	40	✓	PWM/I ² C	—	1.8	WCSP-12	Independently controlled LED channels		0.36

*Suggested resale price in U.S. dollars in quantities of 1,000.

Display Power and Backlighting

LED Backlighting

Backlight WLED Drivers (Continued)

Device	V _{IN} (V)	Synchronous	Type	V _{OUT} Mode	LED Configuration	Switch Current Limit (typ) (mA)	Output Overvoltage Protection (min) (V)	Load-Disconnect During Shutdown	Dimming Control	Quiescent Current (typ) (mA)	Shutdown Current (typ) (µA)	Package(s)	Notes	Automotive Grade	Price*
LM3631	2.7 to 5		Inductive		2P8S	900	28.8	✓	PWM/ ² C	0.06	1	WCSP-24	Includes LCD Bias supply + 2 LDO's		1.20
LM3632A	2.7 to 5		Inductive		2P8S	900	28.8	✓	PWM/ ² C	1.1	1	WCSP-30	Includes LCD Bias supply + LED camera flash		0.95
LM3633	2.7 to 5.5		Inductive		3P10S	1000	40	✓	PWM/ ² C	1.35	1	WCSP-20	Includes 6 low-side indicator drivers		0.70
LM36922	2.5 to 5.5		Inductive		2P8S	1500	28	✓	PWM/ ² C	—	1.2	WCSP-12			0.45
LM36922H	2.5 to 5.5		Inductive		2P11S	1500	38	✓	PWM/ ² C	—	1.2	WCSP-12			0.45
LM36923	2.5 to 5.5		Inductive		3P8S	1500	28	✓	PWM/ ² C	—	1.2	WCSP-12			0.45
LM36923H	2.5 to 5.5		Inductive		3P11S	1500	38	✓	PWM/ ² C	—	1.2	WCSP-12			0.45
LM3697	2.7 to 5.5		Inductive		3P7S	1000	39	✓	PWM/ ² C	—	1.8	WCSP-12			0.40
LM2756	2.7 to 5.5		Charge pump		8P	—	—	✓	I ² C	2.1	3.7	WCSP-20			1.40
LM8502	2.7 to 5.1	✓	Inductive		10P	—	—	✓	PWM/ ² C/ALS	—	—	WCSP-30	Includes LED camera flash		1.50
TPS60230	2.7 to 6.5		Charge pump		Parallel	—	—		PWM	0.200	0.1	QFN-16			0.48
TPS60250/5	2.7 to 6		Charge pump		Parallel	—	—		I ² C	6.7	1.3	QFN-16			0.80
TPS60251	3 to 6		Charge pump		Parallel	—	—		I ² C	6.7	1.3	QFN-24			0.80
TPS75103	2.7 to 5.5		Current sink		Parallel	—	—		PWM	0.18	0.1	WCSP-9			0.65
TCA6507	1.65 to 3.6		Parallel		Parallel	—	—		PWM	—	—	WCSP-12/QFN-12			0.80
TPS61177	2.5 to 24		Inductive		6P12S	2.2	40		PWM	3.5	10	VQFN 20			0.66
TPS61187	4.5 to 24		Inductive		6P11S	2	40		PWM	4	11	TQFN 20			0.78
TPS61197	8 to 30		Inductive		Series	External FET	300		PWM	2	25	SOIC 16			0.68
TPS61500	3 to 18		Inductive		Series	3.8	40		PWM	3.5	1.5	TSSOP 14			0.80

*Suggested resale price in U.S. dollars in quantities of 1,000.

Device	No. of Chan.	V _{IN} Min (V)	V _{IN} Max (V)	Output Current I _{LED} (mA)	Channel-to-Channel Accuracy (%)	Dev.-to-Dev. Accuracy (%)	Short Detection	Open Detection	Overtemperature Detection	Comments	Price*
LED Drivers											
TLC5960	8	10	28	350 ¹	0.3	±1	✓	✓	✓	4 iHVM™ outputs, 4 PWM controls, external FET	1.10

¹TLC5960 output current is limited by external FET.

*Suggested resale price in U.S. dollars in quantities of 1,000.

Device	Typical Power Level	Topology	Maximum Practical Frequency (kHz)	Start-Up Current (µA)	Operating Current (mA)	Supply Voltage (V)	UVLO: On/Off (V)	Max Duty Cycle (%)	Soft Start	Output Drive (Sink/Source) (A)	Package(s)	Price*
LLC Controllers												
UCC25600	200 W to 1 kW	Half-bridge	350	100	7.5	11.5 to 18	11.1/8.9	Variable	✓	0.4/0.8	8-SOIC	0.80
UCC25710	80 W to 500 W	Half-bridge	300	—	—	12 to 18	10/8.5	—	✓	0.4/0.8	20-SOIC	1.50

Note: UCC2xxx devices are extended temperature-range versions of the UCC3xxx devices.

*Suggested resale price in U.S. dollars in quantities of 1,000.

Supervisors and Reset ICs

Overview and Selection Guide

Supervisory Circuits and Reset ICs Family of Products

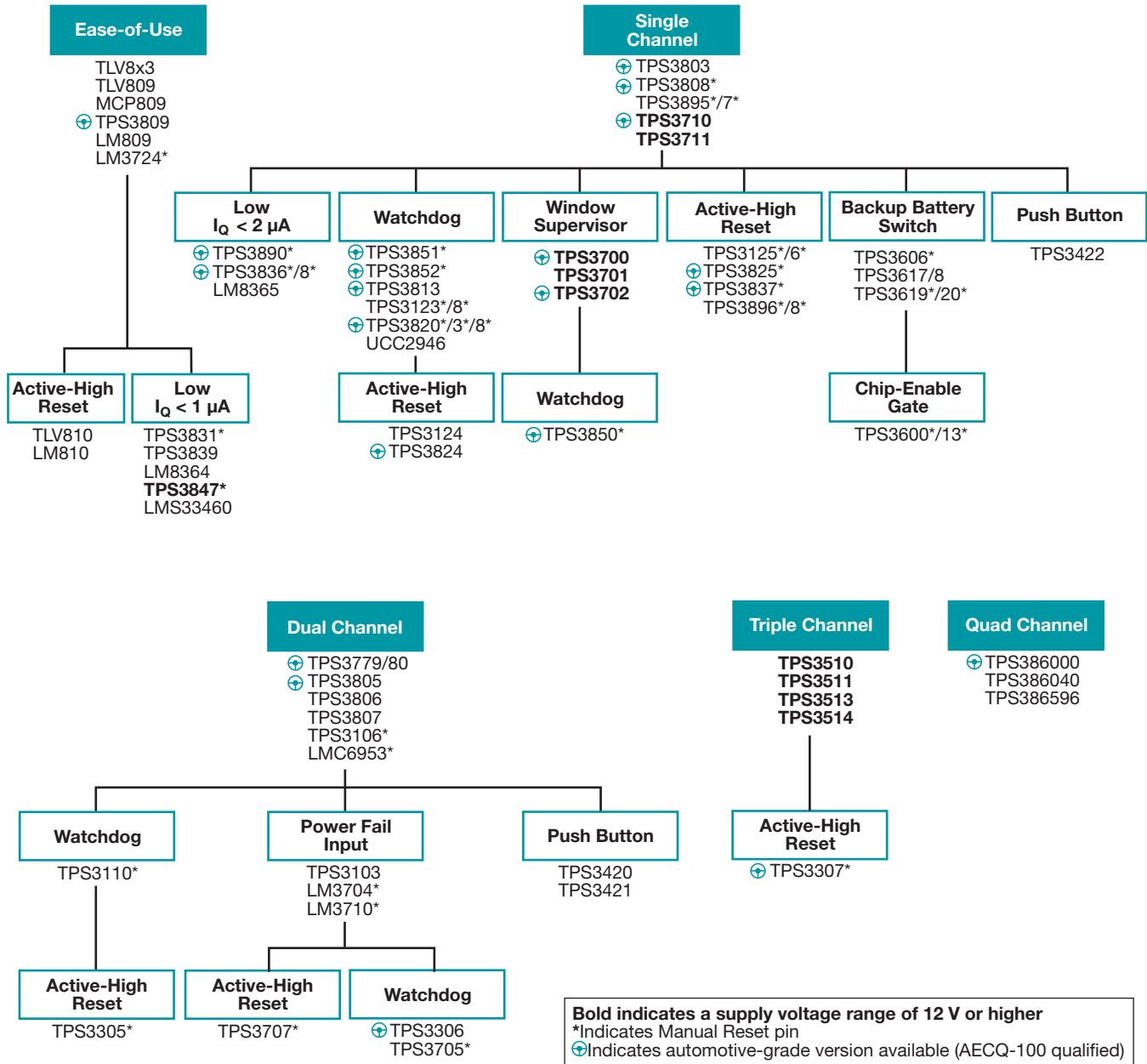

For more information, please visit: www.ti.com/supervisors

Supervisor and Reset ICs

Selection Guide

Supervisors and Reset ICs

Device	Number of Supervisors	Supervised Voltages	Package(s)	V _{DD} Range (V)	I _{DD} (typ) (µA)	Time Delay (ms)	Watchdog Timer WDI (sec)	Reset Threshold Accuracy (%)	Manual Reset/Enable Reset	Active-Low Reset/Output	Active-High Reset/Output	Reset Output Topology ¹	Power-Fail PFI/PFO	Overvoltage Detection	Overcurrent Detection	Chip-Enabled Gating	Comments	Automotive Grade	Price*
Ease-of-Use																			
TLV8x3	1	2.5/3.3/5.0	SOT-23-3	1.1 to 6	9	200		±2.2	✓			OD							0.20
TLV809	1	2.5/3.0/3.3/5.0	SOT-23-3	2.0 to 6.0	9	200		±2.2	✓			PP							0.25
MCP809	1	3.0	SOT-23-3	1.0 to 5.5	15	240		±1.5	✓			OD							0.19
TLV810	1	2.5/3.3/5.0	SOT-23-3	1.1 to 6	9	200		±2.2		✓		PP							0.20
TPS3809	1	2.5/5.0	SOT-23-3	1.8 to 6.5	10	200		±2.2	✓			PP						✓	0.70
LM809	1	2.63, 2.93, 3.08, 4.38, 4.63	SOT-23-3	1.0 to 6	15	240		±1.5	✓			PP							0.23
LM810	1	4.63	SOT-23-3	1.0 to 6	15	240		±1.5		✓		PP							0.23
LM3724	1	2.32, 3.08, 4.63	SOT-23-5	1.0 to 5.5	6	190		±2.5	✓	✓		OD							0.75
TPS3831	1		SON-4	0.6 to 6.5	0.15	200		-2.5 / +1.5	✓	✓		PP					Nano Iq, Ultra small		0.30
TPS3839	1		SON-4, SOT-23-3	0.6 to 6.5	0.15	200		-2.5 / +1.5		✓		PP					Nano Iq, Ultra small		0.21
TPS3847	1	12	SOT-23-5	4.5 to 18	0.38	20		±2.5	✓	✓		PP					Wide Vin		0.85
LM8364	1	2.0	SOT-23-5	1.0 to 6	0.65			±2.5		✓		OD							0.24
LMS33460	1	3.0	SC-70-5	1.0 to 7	1			±5		✓		OD							0.17
Single Channel																			
TPS3890	1	Adj./1.2/1.5/1.8/2.5/3.0/3.3/5.0	SON-6	1.5 to 5.5	2.1	Prog		0.5	✓	✓		OD					Ultra small	✓	0.55
TPS3895/7	1	Adj.	SON-6	1.7 to 6.5	6	Prog		0.25	✓	✓		PP/OD					Ultra small		0.60
TPS3896/8	1	Adj.	SON-6	1.7 to 6.5	6	Prog		0.25	✓	✓		PP/OD					Ultra small		0.60
TPS3836/8	1	1.8/2.5/3.0/3.3	SOT-23-5, SON-6	1.6 to 6.0	0.22	10/200		2.5	✓	✓		PP/OD					Nano Iq	✓	0.85
TPS3837	1	1.8/2.5/3.0/3.3	SOT-23-5	1.6 to 6.0	0.22	10/200		2.4	✓	✓		PP					Nano Iq	✓	0.85
LM8365	1	2.75, 4.5	SOT-23-5	1.0 to 6	0.65	Prog		±2.5		✓		OD					Low Iq		0.25
TPS3803	1	Adj./1.5	SC-70-5	1.3 to 6.0	3			1.5		✓		OD						✓	0.25
TPS3808	1	Adj./0.9/1.2/1.5/1.8/2.5/3.0/3.3/5.0/EEPROM	SOT-23-6, SON-6	1.8 to 6.5	2.4	Prog		0.5	✓	✓		OD						✓	0.70
TPS3710	1	Adj.	ThinSOT23-6	1.8 to 18	7			0.25		✓		OD					Wide Vin	✓	0.59
TPS3711	1	Adj.	ThinSOT23-6	1.8 to 36	7			0.25		✓		OD					Wide Vin		0.79
TPS3125	1	1.2/1.5/1.8/3.0	SOT-23-5	0.75 to 3.3	14	180		3.6	✓	✓	✓	PP							0.80
TPS3126	1	1.2/1.5/1.8	SOT-23-5	0.75 to 3.3	14	180		3.5	✓	✓	✓	OD							0.80
TPS3825	1	3.3/5.0	SOT-23-5	1.1 to 5.5	15	200		2.2	✓	✓	✓	PP						✓	0.55
Window Supervisor																			
TPS3850	1	Adj./1.2/1.8/3.0/3.3/5.0	DFN-10	1.6 to 6.5	10	Prog.	Adj. Window	±0.8		✓		OD		✓				✓	0.75
TPS3700	2	Adj.	ThinSOT23-6, SON-6	1.8 to 18	5.5			0.25		✓	✓	OD		✓			Window watchdog	✓	0.70
TPS3701	2	Adj.	ThinSOT23-6, SON-6	1.8 to 36	7			0.25		✓	✓	OD		✓			Window watchdog		0.89
TPS3702	2	1.0/1.2/1.8/3.3/5.0	ThinSOT23-6	1.8 to 18	7			0.25		✓	✓	OD		✓			Window watchdog	✓	0.79
Supervisor + Watchdog Timer																			
TPS3851	1	1.8/2.5/3.0/3.3/5.0	DFN-8	1.6 to 6.5	10	200	Adj.	±0.8	✓	✓		OD						✓	0.65
TPS3852	1	3.3	DFN-8	1.6 to 6.5	10	200	Adj. Window	±0.8	✓	✓		OD					Window watchdog	✓	0.65
TPS3813	1	2.5/3.0/3.3/5.0	SOT-23-6	2.0 to 6.0	9	25	Adj. Window	2.2		✓		OD					Window watchdog	✓	0.90
TPS3123	1	1.2/1.5/1.8	SOT-23-5	0.75 to 3.3	14	180	1.4	3.6	✓	✓		PP							0.85
TPS3124	1	1.2/1.5/1.8	SOT-23-5	0.75 to 3.3	14	180	1.4	3.6	✓	✓	✓	PP							0.85
TPS3128	1	1.2/1.5/1.8	SOT-23-5	0.75 to 3.3	14	180	1.4	3.5	✓	✓		OD							0.85
TPS3820/8	1	3.3/5.0	SOT-23-5	1.1 to 5.5	15	25/200	0.2/1.6	2.4	✓	✓		PP/OD						✓	0.65
TPS3823	1	2.5/3.0/3.3/5.0	SOT-23-5	1.1 to 5.5	15	200	1.6	2.4	✓	✓		PP						✓	0.65
TPS3824	1	2.5/3.0/3.3/5.0	SOT-23-5	1.1 to 5.5	15	200	1.6	2.2		✓	✓	PP						✓	0.65
UCC2/3946	1	Adjustable	TSSOP-8	2.1 to 5.5	12	200	1.6	2	✓	✓		PP						✓	1.65
Multiple Channels																			
TPS3779/80	2	Adj.	SON-6, SOT-23-6	1.5 to 6.5	1.8			1		✓		PP/OD					Different Hysteresis Options	✓	0.50
TPS3805	2	Adj./3.3	SC-70-5	1.3 to 6.0	3			1.5		✓		PP						✓	0.34
TPS3806	2	Adj./2.0/3.3	SOT-23-6	1.3 to 6.0	3			2		✓		OD							0.45

¹ PP = push-pull, OD = open drain.

*Suggested resale price in U.S. dollars in quantities of 1,000.

Supervisor and Reset ICs

Selection Guide

Supervisors and Reset ICs (Continued)

Device	Number of Supervisors	Supervised Voltages	Package(s)	V _{DD} Range (V)	I _{DD} (typ) (μA)	Time Delay (ms)	Watchdog Timer WDI (sec)	Reset Threshold Accuracy (%)	Manual Reset/Enable Reset	Active-Low Reset/Output	Active-High Reset/Output	Reset Output Topology ¹	Power-Fail PFI/PFO	Overvoltage Detection	Overcurrent Detection	Chip-Enabled Gating	Comments	Automotive Grade	Price*
Multiple Channels (Continued)																			
TPS3807	2	3/3.5	SC-70-5	1.8 to 6.5	3.5	20		1	✓	✓		OD							0.95
TPS3106	2	Adj./0.9/1.6/3.3	SOT-23-6	0.4 to 3.3	1.2	130		0.75	✓	✓		OD							0.90
LMC6953	2	3.3, 3.5	SOIC-8	1.5 to 6	800	0.0005		±3	✓	✓		OD							1.44
TPS3110	2	Adj./0.9/1.2/1.5/3.3	SOT-23-6	0.4 to 3.3	1.2	130	1.1	0.75	✓	✓		PP							0.99
TPS3305	2	1.8/2.5/3.3/5.0	SO-8, MSOP-8	2.7 to 6.0	15	200	1.6	2.7	✓	✓	✓	PP							1.00
TPS3307	3	Adj./1.8/2.5/3.3/5.0	SO-8, MSOP-8	2.0 to 6.0	15	200		2.7	✓	✓	✓	PP						✓	1.05
TPS3510/1	3	3.3/5.0/12.0	SO-8, DIP-8	4.0 to 15	1 mA	300		9.1	✓	✓		OD	✓	✓			PC power supplies		0.45
TPS3513/4	3	3.3/5.0/12.0	SO-14, DIP-14	4.5 to 15	1 mA	300		9.1	✓	✓		OD	✓	✓	✓		PC power supplies		0.70
TPS3860x0	4	Adj. (includes negative rail)	QFN	1.8 to 6.5	9	Prog	0.6	0.25	✓	✓	✓	PP/OD		✓				✓	1.95
TPS386596	4	Adj./3.0	MSOP-8	1.8 to 6.5	7.5	Prog		0.25	✓	✓		OD		✓					1.25
Power Fail Input																			
TPS3103	2	1.2/1.5/2.0/3.3	SOT-23-6	0.4 to 3.3	1.2	130		0.75	✓	✓		OD	✓						0.90
TPS3705	2	3.0/3.3/5.0	SO-8, MSOP-8	2.0 to 6.0	30	200	1.6	2.1	✓	✓		PP	✓						0.80
TPS3707	2	2.5/3.0/3.3/5.0	SO-8, MSOP-8	2.0 to 6.0	20	200		2.2	✓	✓	✓	PP	✓						0.75
TPS3306	2	1.5/1.8/2.0/2.5/3.3/5.0	SO-8, MSOP-8	2.7 to 6.0	15	100	0.8	2.7	✓	✓		OD	✓					✓	1.05
LM3704	2	2.32, 3.08, 3.6	VSSOP-10	1.0 to 5.5	28	28, 200		±2	✓	✓		PP/OD	✓						0.77
LM3710	2	2.32, 3.08, 4.63	VSSOP-10	1.0 to 5.5	28	28, 200	0.0062 to 25.6	±2	✓	✓		PP/OD	✓						1.10
Battery Backup Switchover Supply Supervisors																			
TPS3600	1	2.0/2.5/3.3/5.0	TSSOP-14	1.6 to 5.5	20	100	0.8	2.3	✓	✓		PP	✓			✓			2.15
TPS3606-33	1	3.3	MSOP-10	1.6 to 5.5	20	100	0.8	2	✓	✓		PP	✓						1.45
TPS3613-01	1	Adjustable	MSOP-10	1.6 to 5.5	20	100		1.7	✓	✓	✓	PP				✓			1.50
TPS3617/8	1	4.55	MSOP-8	1.6 to 5.5	15	100	0.8	2		✓		PP	✓				TPS3617 includes battery freshness seal		1.33
TPS3619/20	1	3.3/5.0	MSOP-8	1.6 to 5.5	15	100		2	✓	✓		PP	✓				TPS3619 includes battery freshness seal		1.10

¹PP = push-pull, OD = open drain.

*Suggested resale price in U.S. dollars in quantities of 1,000.

Sequencers

Selection Guide

Sequencers

Device	Number of Supervisors	Supervised Voltages	Number of Sequenced Outputs	Package(s)	V _{DD} Range (V)	I _{DD} (typ) (μA)	Time Delay (ms)	Comments	Price*
LM3880	—	—	3	SOT23-6	2.7 to 5.5	25	Fixed		0.50
LM3881	—	—	3	MSOP-8	2.7 to 5.5	80	Prog		0.50
TPS386000	4	Prog. by resistors	—	QFN-20	1.8 to 6.5	11	Prog		0.95
UCD9090A	11	Prog. by software GUI	10	QFN-48	3 to 3.6	50 mA	Prog	With NV logging	3.96
UCD90120A	13	Prog. by software GUI	12	QFN-64	3 to 3.6	50 mA	Prog		4.95
UCD90124A	13	Prog. by software GUI	12	QFN-64	3 to 3.6	50 mA	Prog	With fan control	6.45
UCD90160A	16	Prog. by software GUI	—	QFN-64	3 to 3.6	50 mA	Prog	with NV logging	6.20
UCD90910	10	Prog. by software GUI	10	QFN-64	3.3 to 12	50 mA	Prog	With fan control	5.90
UCD90240	24	Prog. by software GUI	24	BGA-157	3.15 to 3.63	31.4 mA	Prog	With blackbox logging and 100 fault logs	10.00
UCD90320	32	Prog. by software GUI	32	BGA-169	3.15 to 3.63	31.4 mA	Prog	With blackbox logging and 100 fault logs	13.30

*Suggested resale price in U.S. dollars in quantities of 1,000.

Power Interface and Protection

Power Over Ethernet (PoE) Solutions

Power Sourcing Type

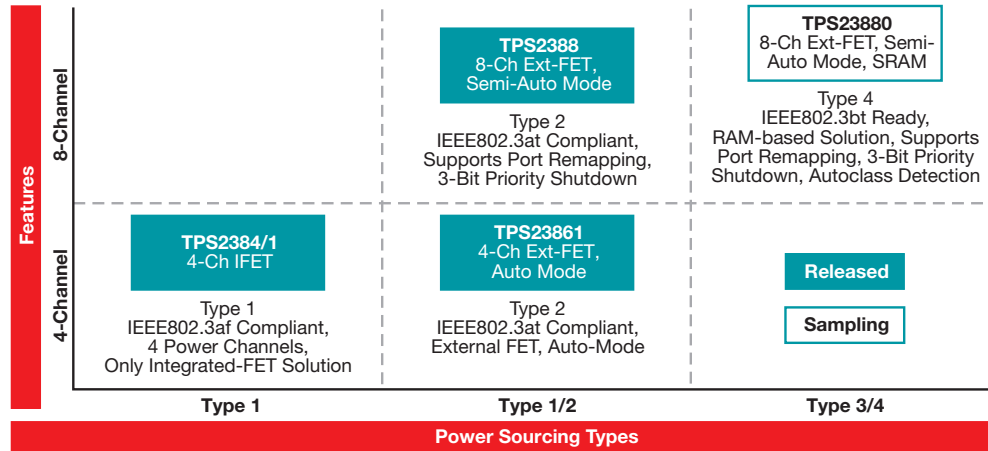

Power Delivery Type

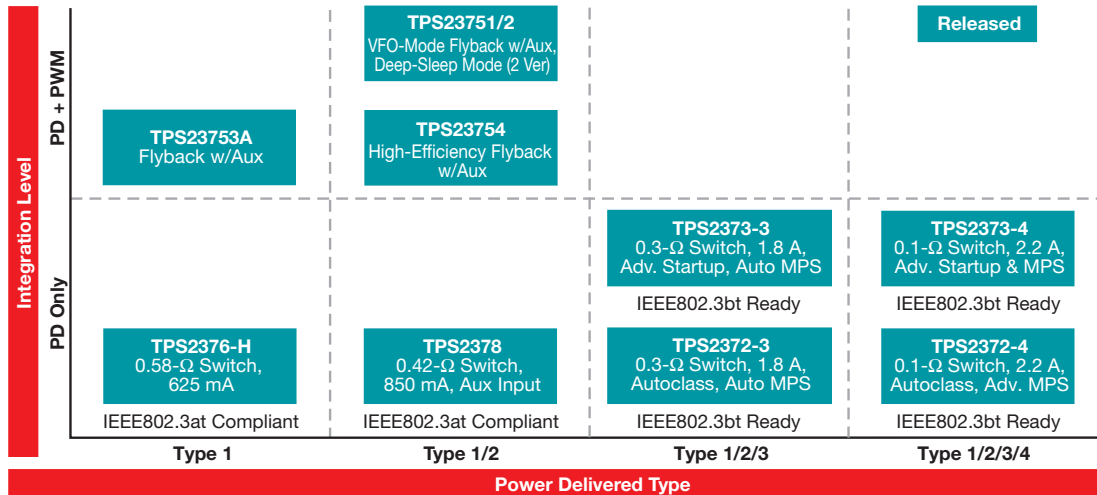

Special Note: Ethernet Alliance Logo Program

Ethernet Alliance (EA) started a certification program in 2017 which tests for compliance to IEEE802.3 PoE standards. Systems with successful test results are granted use of the EA Logo. The following designs have passed these certification tests. For more information, please refer to <https://ethernetalliance.org/poecert/>

PoE EVM/Reference Designs with EA Logos Granted

EVM/Ref Design Number	Description	Device	PD/PSE	Class	EA Logo
PMP9175	Class 3, 5-V/2.3-A isolated flyback, 90% efficient, featuring TPS23753A	TPS23753A	PD	3	
PMP11254	Class 4, 12-V/2.1-A isolated non-synchronous flyback, featuring TPS23751	TPS23751	PD	4	
TPS23754EVM-383	Class 4, 12-V/2.1-A, active-clamp forward EVM	TPS23754	PD	4	
TIDA-01411	Type 2, 6-kV lightning surge rated design, featuring TPS23861	TPS23861	PSE	4	

Power Interface and Protection

Power Over Ethernet (PoE) Solutions

PoE Premiere Reference Designs

Reference Design/EVM Number	Description	Device	PD/PSE	Class
Power Sourcing Equipment (PSE)				
TIDA-00465	Single-port Class 4 PSE	TPS23861	PSE	4
TIDA-01411	Class 4 PSE with 6-kV lightning surge protection	TPS23861	PSE	4
TPS23861EVM-612	IEEE802.3at PSE evaluation module	TPS23861	PSE	4
TPS2388EVM-612	IEEE802.3at PSE evaluation module	TPS2388	PSE	4

For more reference designs, see Tools & Software at: www.ti.com/poe

Reference Design/EVM Number	Description	Device	PD/PSE	Class	Input Voltage (V)	Output	Efficiency (%)
Power Delivery Equipment (PD)							
PMP8803	Class 3 Low-cost flyback converter	TPS23753A	PD	3	36 to 57	12 V at 1 A	90
PMP9175	Class 3 High-efficiency converter	TPS23753A	PD	3	36 to 57	5 V at 2.3 A	90
PMP11254	Class 4 Flyback converter	TPS23751	PD	4	42.5 to 57	12 V at 2.125 A	91
TIDA-00617	Class 4 High-efficiency flyback converter	TPS23751	PD	4	21.6 to 57	5 V at 5 A	92
TIDA-01463	Class 6 PoE lighting driver with autotransformer and ultra-low standby power	TPS2372-4	PD	6	42.5 to 57	40 V at 1.15 A	—
TPS2372-4EVM-006	IEEE802.3bt PD with autotransformer evaluation module (PD only)	TPS2372-4	PD	8	36 to 57	—	—
TPS2373-4EVM-758	IEEE802.3bt PD with advanced start-up, ACF DC/DC	TPS2373-4	PD	8	36 to 57	5 V at 14 A	91
TIDA-00741	Non-standard, UPOE 51W flyback converter	TPS2378	PD	Non-Standard	42.4 to 57	12 V at 3.8 A	92

PoE Power Sourcing Equipment (PSE) Controllers

Device	Applications	Port Count	Abs Max V _{IN} (V)	Operating Temp (°C)	PoE Standards Supported	Modes of Operation	Interface	Disconnect	Measurements	Power FET	Package	Price*
TPS2384	Quad IEEE 802.3af PoE PSE controller with integrated FETs	4	80	-40 to 125	802.3af	Auto, Semi-Auto, Manual	i ² C	Both AC and DC	Current, voltage, capacitance and temperature	Internal	64-pin LQFP	4.75
TPS23861	Quad IEEE 802.3at PoE PSE controller	4	70	-40 to 125	802.3at	Autonomous, Auto, Semi-Auto, Manual	Optional i ² C	DC	Current, voltage and temperature	External	28-pin TSSOP	1.75
TPS2388	Octal IEEE 802.3at PoE PSE controller	8	70	-40 to 125	802.3at	Semi-Auto, Manual	i ² C	DC	Current, voltage and temperature	External	56-pin VQFN	3.50
TPS23880	Octal IEEE 802.3bt-ready PoE PSE controller	8	70	-40 to 125	802.3bt	Auto, Semi-Auto, Manual	i ² C	DC	Current, voltage and temperature	External	56-Pin VQFN	TBA

*Suggested resale price in U.S. dollars in quantities of 1,000.

Preview devices are listed in **bold teal**.

PoE Powered Device (PD) Controllers

Device	Description	PoE Standards Supported	Power Level (W)	Maximum Classification Supported	Abs Max V _{IN} (V)	Operating Temp (°C)	Inrush Current Limiting (mA)	Current Limit (mA)	Second Gate Driver for Maximum Efficiency	Package(s)	Price*
PD Controllers with Integrated DC/DC Controllers											
TPS23750/70	Integrated PD with PWM controller	802.3af	13	3	100	-40 to 125	140	450	No	TSSOP-20	1.25/1.12
TPS23751/2	PD with Green Mode/Deep Sleep Mode PWM	802.3at	25	4	100	-40 to 125	140	1000	No	TSSOP-20	1.10
TPS23753A	PD+controller with AUX ORing	802.3af	13	3	100	-40 to 125	140	450	No	TSSOP-14	0.90
TPS23754/6	High-efficiency flyback/forward with Aux	802.3at	25	4	100	-40 to 125	140	970	Yes	TSSOP-20 PowerPAD™	1.20/1.25
TPS23757	PD + high-efficiency controller	802.3af	13	3	100	-40 to 125	140	465	Yes	TSSOP-20	1.20

Device	Description	PoE Standards Supported	Power Level (W)	Maximum Classification Supported	Abs Max V _{IN} (V)	Operating Temp (°C)	Inrush Current Limiting (mA)	Current Limit (mA)	UVLO (V)	Package(s)	Price*
PD Interface Front-End Controllers											
TPS2376-H	600-mA capable PD controller	802.3af	25	Nonstandard	100	-40 to 85	Programmable	625 (min)	Adjustable	SOIC-8	0.59
TPS2378	PD with AUX control	802.3at	25	4	100	-40 to 85	140	850 (min)	32/38.1	SOIC-8	0.65
TPS2379	PD with high power	Nonstandard	+25	Nonstandard	100	-40 to 85	140	850 (min)	32/38.1	SOIC-8	1.00
TPS2372-3/-4	PD with autotransformer	802.3bt	51/71.3	6 / 8	100	-40 to 125	200/335	1850/2200 (typ)	32/38.1	VQFN-20	1.10/1.35
TPS2373-3/-4	PD with advanced startup	802.3bt	51/71.3	6 / 8	100	-40 to 125	200/335	1850/2200 (typ)	32/38.1	VQFN-20	1.25/1.50

*Suggested resale price in U.S. dollars in quantities of 1,000.

New devices are listed in **bold red**.

Power Interface and Protection

USB Power and Charging Port Controllers

1 & 2 Channels, 4.5- to 5.5-V USB Switches

Channels	Rated Current Amps	Enable Polarity	Output Discharge	SOIC	MSOP DGN PowerPAD™	MSOP DGK	SOT-23	SON DRC
1	0.5	L	Y				TPS2041CDBV	
		H	Y				TPS2051CDBV	
	1	L	Y		TPS2061CDGN		TPS2061CDBV	
			N		TPS2065CDGN		TPS2065CDBV	
		H	Y		TPS2065CDGN-2		TPS2065CDBV-2	
	1.5	L	Y		TPS2068CDGN			
		H	Y		TPS2069CDGN		TPS2069CDBV	
	2	L	Y		TPS2000CDGN	TPS2000CDGK		
		H	Y		TPS2001CDGN	TPS2001DDGK	TPS2001DDBV	
	2	0.5	H	Y		TPS2052CDGN		
1		L	Y	TPS2062CD	TPS2062CDGN			
			N					TPS2062CDRB-2
		H	Y	TPS2066CD	TPS2066CDGN			
			N		TPS2066CDGN-2			
1.5		L	Y		TPS2060CDGN			
		H	Y		TPS2064CDGN			
2		L	Y					TPS2002CDRC
		H	Y					TPS2003CDRC

Value devices are listed in **bold red**.

Fixed I_{LIMIT} Single Channel, 2.7- to 5.5-V USB Switches

Rated Current Amps	Enable Polarity	Output Discharge	SOIC D	MSOP DGN PowerPAD™	SOT-23 DBV	P
0.1	L	N	TPS2049D			
0.2	L	N	TPS2020D, TPS2020IDRQ1			
	H	N	TPS2030D, TPS2030DRQ1			TPS2030P
0.25	L	N	TPS2045AD			
	H	N	TPS2055AD			
0.5	L	N	TPS2041BD	TPS2041BDGN	TPS2530BV, TPS2041BDBV, TPS2041BMDBVTEP, TPS2041BQDBVVRQ1	
	H	N	TPS2051BD, TPS2051BQDRQ1	TPS2051BDGN	TPS2051BDBV	
0.6	L	N	TPS2021D, TPS2021DRQ1			TPS2021P
	H	N	TPS2031D			TPS2031P
1	L	N	TPS2022D, TPS2022DRQ1, TPS2061D	TPS2061DGN	TPS2061DBV	
	H	N	TPS2065D, TPS2032D, TPS2032DRQ1	TPS2065DGN-1, TPS2065DGN, TPS2065DGNRQ1	TPS2065DBV	
1.5	L	N	TPS2023D, TPS2068D, TPS2068IDGNRQ1	TPS2068DGN		TPS2023P
	H	N	TPS2033D	TPS2069DGN		
2	L	N	TPS2024D, TPS2024IDRQ1			TPS2024P
	H	N	TPS2034D			TPS2034P

Automotive Q100 devices are listed in **bold teal**. Value devices are listed in **bold red**.

Most TI USB switches are recognized by UL under UL2367. Please consult datasheet for latest status.

Power Interface and Protection

USB Power and Charging Port Controllers

Fixed I_{LIMIT} Dual Channels, 2.7- to 5.5-V USB Switches

Rated Current Amps	Enable Polarity	Output Discharge	SOIC D	MSOP DGN PowerPAD™	SON DRC
0.25	L	N	TPS2046BD		
	H	N	TPS2056AD		
0.5	L	N	TPS2042BD, TPS2042BQDRQ1	TPS2042BDGN	TPS2042BDRB
	H	N	TPS2052BD	TPS2052BDGN	TPS2052BDRB
1	L	Y	TPS2062D-1		
		N	TPS2062AD, TPS2062D	TPS2062QDGNRQ1, TPS2062DGN	TPS2062ADBR
	H	Y		TPS2066DGN-1	
		N	TPS2066AD, TPS2066D	TPS2066DGN, TPS2066DGNRQ1	TPS2066ADBR
1.5	L	N		TPS2060DGN	TPS2060DBR
	H	N		TPS2064DGN	TPS2064DBR

Automotive Q100 devices are listed in bold teal.

Fixed I_{LIMIT} with Boost Converter USB Switches

V Operating	USB Channels	I_{LIMIT} Adj. Range (Amps/Channel)	3.3-V LDO	Enable Polarity	$F_{VARIABLE}$ Eco-mode™	QFN20	SON10 DRC
1.8 to 5.5	1	0.13 to 1.4	No	H	Yes		TPS2500
	2	0.1 to 1.1	Yes		No		TPS2501
					Yes	TPS2505	

Fixed I_{LIMIT} 3 & 4 Channels, 2.7- to 5.5-V USB Switches

V Operating	Channels	Rated Current Amps	Enable Polarity	SOIC D16
2.7 to 5.5	3	0.25	L	TPS2047BD
			H	TPS2057AD
		0.5	L	TPS2043BD
			H	TPS2053BD
		1	L	TPS2063D
			H	TPS2067D
	4	0.25	L	TPS2048AD
			H	TPS2058AD
		0.5	L	TPS2044BD
			H	TPS2054BD

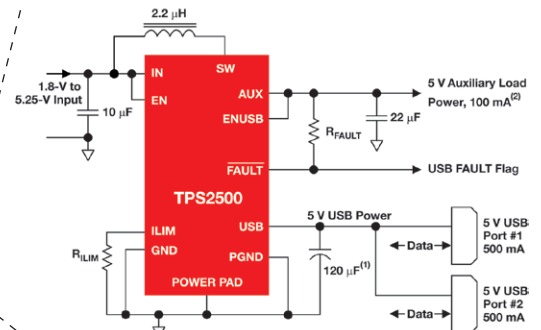

TPS2500 application diagram.

Precision Adjustable Limit Switches

Channels	$I_{CONT.}$ Adj. Range (Amps/Channel)	V Operating	V_{ABSMAX}	Number of Programmable Thresholds	Latch Off Retry	Output Discharge	Active Reverse Current Blocking Threshold (mV)	R_{ON} (mΩ)	Packages	Device						
1	0.1 to 1.0	2.5 to 6.5	7	1	Retry	No	135	85	SOT 23-6	TPS2551QDBVRQ1						
	85							SOT 23-6	TPS2552DBV							
	100							SON6 2x2 mm	TPS2552DRV							
	85							SOT 23-6	TPS2552DBV-1							
	100							SON6 2x2 mm	TPS2552DRV-1							
	85							SOT 23-6	TPS2553DBV							
	100							SON6 2x2 mm	TPS2553QDBVRQ1							
	100							SON6 2x2 mm	TPS2553DRV							
	85							SOT 23-6	TPS2553DBV-1							
	100							SON6 2x2 mm	TPS2553DRV-1							
	0.28 to 2.0							2.5 to 5.5	6	1	Retry	No	N/A	70	SOT 23-6	TPS25221DBV
															SON6	TPS25221DRV
	0.075 to 2.5							2.5 to 6.5	20	1	Latch Off	No	N/A	60	WSO6 2x2 mm	TPS25200DRV TPS25200QDRVRQ1
	0.5 to 2.5 Dual Adjustable, Selectable							4.5 to 5.5	7	2	Retry	Yes	N/A	73	SON10 3x3 mm	TPS2555DRC
								SON10 3x3 mm	TPS2554DRC							
0.5 to 5.0	2.5 to 6.5	7	1	Retry	No	N/A	22	SON8 3x3 mm	TPS2556DRB TPS2556QDRBRQ1							
								SON8 3x3 mm	TPS2557DRB TPS2557QDRBRQ1							
1.2 to 4.7							13	SON10 3x3 mm	TPS2559DRC							
2	0.25 to 2.8	2.5 to 6.5	7	1	Retry	No	N/A	45	SON10 3x3 mm	TPS2560DRC						
								SON10 3x3 mm	TPS2561DRC TPS2561QDRCRQ1							
								SON10 3x3 mm	TPS2560ADRC							
								SON10 3x3 mm	TPS2561ADRC							
								SON10 3x3 mm	TPS2561AQDRCRQ1							

Most TI USB switches are recognized by UL under UL2367. Please consult datasheet for latest status.

Automotive Q100 devices are listed in bold teal. Value devices are listed in bold red.

Power Interface and Protection

USB Power and Charging Port Controllers

USB Charge Port Controllers (USB CPC) Features Matrix

Device	Typ. R _{ON} (mΩ)	I _{CONT} Max (A)	iOS ID(s) (A)	1.2/1.2 V Divide Mode	BC1.2 Mode(s) Supported	S3 Mouse HID Wake	Power Wake, Port Power Mgmt	Cable Comp	Short to V _{BATT} Protect	IMON	Package
TPS254900-Q1	45	3.1	N/A	No	SDP, CDP	No	No	Linear	Yes	Yes	QFN 20
TPS2549/49-Q1	47	3.1	2.4	Yes	SDP, CDP	No	No	Linear	No	Yes	QFN 16
TPS2513A/4A/3AQ1/4A-Q1	N/A	N/A	2.4	Yes	DCP	No	No	No	No	No	SOT-23
TPS2513/14	N/A	N/A	1, 2	Yes	DCP	No	No	No	No	No	SOT-23
TPS2511/-Q1	70	2.7	1, 2	Yes	DCP	No	No	1 Step	No	No	MSOP 8
TPS2547	73	3.1	1, 2	Yes	SDP, CDP	LS/FS	Yes	No	No	No	QFN 16
TPS2546/-Q1	73	2.7	1, 2	Yes	SDP, CDP	LS/FS	Yes	No	No	No	QFN 16
TPS2544	73	2.7	1, 2	Yes	SDP, CDP	LS/FS	No	No	No	No	QFN 16
TPS2543/-Q1	73	2.7	1, 2	No	SDP, CDP	LS	Yes	No	No	No	QFN 16
TPS2540A/1A	73	2.5	1	No	SDP, CDP	No	No	No	No	No	QFN 16
TPS2540/1	73	2.5	1	No	SDP, CDP	No	No	No	No	No	QFN 16

All devices with switches (except TPS254900-Q1) are UL recognized or recognition is pending. TPS254900 is AEC-Q100 Qualified.
 iOS devices with up to date SW will recognize any of the charge current IDs (divider modes).
 SDP = BC1.2 Standard downstream port, supports USB 2.0 (500 mA) and USB 3.0 (900 mA).

Automotive Q100 devices are listed in bold teal. New devices are listed in bold red.
 CDP = BC1.2 Charging downstream port, supports data and charging to 1.5 A.
 DCP = BC1.2 Dedicated charging port, supports charging to 1.5 A but not data (wall charger).
 TPS2513/A = 2 Channels; TPS2514/A = 1 Channel; TPS2513A/14A support 2.7/2.7V divider mode.

USB Charging Port Controllers

Device	Internal Power Switch	CDP	SDP	DCP/Auto					S3 Mouse HID Wake	Load Detect	UL Listed	Package(s)
				BC1.2 Mode	Divide Mode 1 2.0/2.7 V	Divide Mode 2 2.7/2.0 V	1.2/1.2 V	Divide Mode 3 2.7/2.7 V				
TPS2513A/3AQ100/4A	No	No	No	Yes	Yes	Yes	Yes	Yes	No	No	No	SOT-23
TPS2513/14	No	No	No	Yes	Yes	Yes	Yes	No	No	No	No	SOT-23
TPS2511/Q100	Yes	No	No	Yes	Yes	Yes	Yes	No	No	50% of I _{LIMIT}	Yes	MSOP 8
TPS2546	Yes	Yes	Yes	Yes	Yes	Yes	Yes	No	LS/FS	50 mA	Yes	QFN 16
TPS2544	Yes	Yes	Yes	Yes	Yes	Yes	Yes	No	LS/FS	No	Yes	QFN 16
TPS2543/Q100	Yes	Yes	Yes	Yes	Yes	Yes	No	No	LS	50 mA	Yes	QFN 16
TPS2547	Yes	Yes	Yes	Yes	Yes	Yes	Yes	No	LS/FS	50 mA	Yes	QFN 16

All switch devices are UL recognized.
 SDP = BC1.2 standard downstream port, supports USB 2.0 (500 mA) and USB 3.0 (900 mA).
 CDP = BC1.2 charging downstream port, supports charging to 1.5 A.
 DCP = BC1.2 dedicated charging port, a stand-alone charger with no data path (wall charger).
 Divider mode 2 allows charging to 2.1 A.

TPS2547 pin/function compatible with TPS2546 (with improved 3-A current switch and removal of CDP-SDP auto switch).
 TPS2546 pin/function compatible to TPS2543; TPS2544 pin/function compatible to TPS2543/6.
 TPS2513/A = 2 channels; TPS2514/A = 1 channel; TPS2513A/14A support 2.7/2.7-V divider mode.

Most TI USB switches are recognized by UL under UL2367. Please consult datasheet for latest status.

USB Type C Controller with Power Switch

Device	Power Role	Data Role	Internal Power Path	External Power Path Control	Alternate Mode	V _{BUS} Application	V _{CONN} Application	Package
TPS25810	Source	DFP	Type-C 5-V 3-A Power Supply	No	No	Yes	Yes	QFN 20
TPS25820	Source	DFP	Type-C 5-V 1.5-A Power Supply	No	No	Yes	Yes	WSON 12
TPS25740B	Source	DFP	N/A	Yes	No	Yes	No	QFN 24
TPS65981	Source, Sink, DRP	DFP, UFP, DRD	Type C PD 20-V 3-A Power Supply	Yes	Yes	Yes	Yes	QFN 56
TPS65986	Source, Sink, DRP	DFP, UFP, DRD	Type C PD 20-V 3-A Power Supply	Yes	Yes	Yes	Yes	BGA 96

USB Type C Short-to-V_{BUS} Protection

Device	Description	CC1/CC2 20-V Short-to-V _{BUS}	SBU1/SBU2 or D+/D- 20-V Short-to-V _{BUS}	CC1/CC2 IEC ESD	SBU1/SBU2 IEC ESD	D+/D- IEC ESD	V _{CONN} Support	V _{BUS} Protection	Package
TPD8S300	USB Type-C™ Port Protector: Short-to-V _{BUS} Overvoltage and IEC ESD Protection	✓	✓	✓	✓	4CH ESD	600-mA Support	N/A	QFN-20 (3x3 mm)
TPD6S300	USB Type-C Port Protector: Short-to-V _{BUS} Overvoltage and IEC ESD Protection	✓	✓	✓	✓	2CH ESD	600-mA Support	N/A	QFN-20 (3x3 mm)
TPD2S300	USB Type-C Short-to-V _{BUS} and IEC ESD Protector for CC	✓		✓		N/A	Adjustable	N/A	WCSP-9 (1.4x1.4 mm)
TPS65990	USB Type-C Bi-Directional Power Mux with CC and SBU Short-to-V _{BUS} Protection and Dead Battery LDO	✓	✓	✓	✓	N/A	Provides 600-mA w/OCV	5-A OCP, OVP, RCP, FRS, Sink/Source, LDO	QFN-38 (4x6 mm)

Power Interface and Protection

USB Power and Charging Port Controllers

Overview of USB Charging Handshakes

TI USB charging controllers support, to varying degrees, four of the most common USB charging schemes found in popular handheld media and cellular devices:

- USB Battery Charging Specification BC1.2
- Chinese Telecommunications Industry Standard YD/T 1591-2009
- Divider Mode 1 and Divider Mode 2
- 1.2-V mode

YD/T 1591-2009 is a subset of the BC1.2 specification which supports the vast majority of devices that implement USB charging. Divider Modes 1 and 2 and 1.2-V charging schemes support popular devices from specific manufacturers. BC1.2 lists three different port types as listed below.

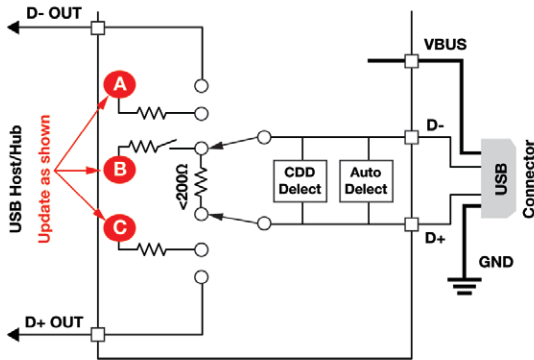

USB charging controller handshake interface.

Handshaking Schemes Supported by TI USB Charging Controllers

Mode	Switch		Node (V)		
	D-	D+	A	B	C
BC1.2	200 Ω to D+	200 Ω to D-	—	—	—
Divider 1	2.7 V	2.0 V	2.7	—	2.0
Divider 2	2.0 V	2.7 V	2.0	—	2.7
Divider 3	2.7 V	2.7 V	2.7	—	2.7
1.2 V	1.2 V	1.2 V	—	1.2	—

DCP BC1.2 and YD/T 1591-2009

Both standards define that the D+ and D- data lines should be shorted together at the host with a maximum series impedance of 200 Ω as shown here in the table and figure.

DCP Divider Charging Scheme

Some charging controllers support Divider Modes 1 and 2. The DCP interface configurations for Divider 1 and Divider 2 are shown in the table and figure. Divider 1 charging applies 2.0 V and 2.7 V to D+ and D- data lines, respectively. This is reversed in Divider Mode 2. Divider Mode 3 applies 2.7 V to D+ and D- and supports 2.4-A charging.

DCP 1.2-V Charging Scheme

1.2-V charging scheme is used by some handheld devices to enable fast charging at 2.0 A. Certain devices (as shown) support this scheme in the DCP-Auto mode before the device enters BC1.2 shorted mode. To simulate this charging scheme, D+/D- lines are shorted and pulled up to 1.2 V for a fixed duration; then the device moves to DCP shorted mode as defined in BC1.2 specification.

Most TI USB switches are recognized by UL under UL2367. Please consult datasheet for latest status.

Power Interface and Protection

Interface Protection

Current Sense Amplifiers

Device	Description	Common-Mode Range		Gain (V/V)	Output Type	Input Offset (+/-)(max) (μ V)	CMRR (min) (dB)	Quiescent Current (+/-)(typ) (mA)	V_S		Package(s)	Automotive Grade	Price*
		(min) (V)	(max) (V)						(min) (V)	(max) (V)			
INA226	High-side measurement, bi-directional current power monitor with I ² C interface	0	36	1	I ² C	10	126	0.33	2.7	5.5	MSOP-10		1.30
INA210	Voltage output, high/low-side measurement, bi-directional zero-drift series current power monitor	-0.3	26	200	Voltage	35	105	0.065	2.7	26	μ QFN-10, SC70-6		0.65
INA219	Zero-drift, bi-directional current power monitor	0	26	Programmable	I ² C	50	100	0.7	3	5.5	SOIC-8, SOT-23-8		0.80
INA230	Precision digital/current/voltage/power monitor	0	28	1	I ² C	50	100	330	2.7	5.5	QFN-16		1.15
INA282	Wide common mode range, bidirectional, high accuracy current power monitor	-14	80	50	Voltage	70	120	0.6	2.7	18	SOIC-8	✓	1.25
LMP8640	Precision high-voltage current sense amplifier	-2	76	20, 50, 100	Voltage	900	60	0.72	2.7	12	SOT-6		0.89
LMP8645	Precision high-voltage current sense amplifier	-2	76	Programmable	Voltage	1000	60	0.61	2.7	12	SOT-6		0.89
LMP8646	Precision current limiter	-2	76	Programmable	Voltage	1000	95	0.38	2.7	12	SOT-6		1.20

*Suggested resale price in U.S. dollars in quantities of 1,000.

Protection and Monitoring with I²C/PMBus™

Device	V_{IN} Range (V)	Enable/Shutdown	UV	OV	Fault	PG	Latch	Auto Retry	Interface	FET SOA Protection	Package(s)
LM25066/A	2.9 to 17	1H	✓	✓	✓	✓	Prog	Prog	I ² C, SMBus, PMBus	Yes	24-pin LLP
LM25066i/A	2.9 to 17	1H	✓	✓	✓	✓	Prog	Prog	I ² C, SMBus, PMBus	Yes	24-pin LLP
TPS2480/1	9 to 24	1H	✓			✓	Prog	Prog	I ² C	Yes	20-pin TSSOP
TPS2482/3	9 to 36	1H	✓			✓	Prog	Prog	I ² C	Yes	20-pin TSSOP
LM5066	10 to 80	1H	✓	✓	✓	✓	Prog	Prog	I ² C, SMBus, PMBus	Yes	28-pin eTSSOP
LM5066i	10- to 80-V hotswap power monitor with Intel node-manager compliance	1H	✓	✓	✓	✓	Prog	Prog	I ² C, SMBus, PMBus	Yes	28-pin eTSSOP
LM5064	-10 to -80	1H	✓	✓	✓	✓	Prog	Prog	I ² C, SMBus, PMBus	Yes	28-pin eTSSOP

*Suggested resale price in U.S. dollars in quantities of 1,000.

Monitoring with I²C/PMBus

Device	V_{IN} Range (V)	Enable/Shutdown	Fault	Telemetry Data				Interface	Package(s)
				V_{IN}	I_{IN}	P_{IN}	Temp		
LM25056/A	3 to 17	1H	✓	✓	✓	✓	✓	I ² C, SMBus, PMBus	24-pin LLP
LM5056	10 to 80	1H	✓	✓	✓	✓	✓	I ² C, SMBus, PMBus	28-pin TSSOP

*Suggested resale price in U.S. dollars in quantities of 1,000.

Power Switches

Overview

Power Switches provide an electrical connection from a voltage source to a load. A power switch saves power across multiple voltage rails and protects subsystems from damage. It also provides enhanced component protection, inrush current protection, and minimizes printed-circuit board (PCB) size. There are several power-switch topologies and each addresses a different application.

- **Load switches** establish the power-switch foundation by providing safe and reliable distribution of power. They do power distribution, power sequencing, inrush current control and reduce current leakage.
- **Power MUX** devices are similar to load switches and can seamlessly switch between different input-power sources while providing protection features.
- **eFuses and hot-swap controllers** offer additional power-path protection features such as current sense monitoring, current limiting, under- and overvoltage protection, and thermal shutdown. They are ideal for hot-plug and transient events that could damage a system.
- **Ideal diode controllers** provide protection against reverse polarity conditions by monitoring an external FET, which significantly reduces power loss and blocks reverse current.
- **Smart high-side switches** provide diagnostic telemetry that monitors the output load current and detects short-circuit and open-load events.
- **Low-side switches** connect the load to ground, instead of power supply to load, and by including an integrated flyback diode, they help to eliminate inductive load transients by dissipating current in a circular loop.

For more information, see “Basics of Power Switches” at www.ti.com/lit/SLVA927

Power Switches Topology

Feature	Load Switch	Power Mux	eFuse	Hot Swap	Ideal Diode Controller	Smart High-Side Switch	Low-Side Switch
Voltage Range	0 to 18 V	2.8 to 5.5 V	1.62 to 55 V	±80 V	±75 V	0.3 to 40 V	0 to 100 V
Maximum Operating Current	15 A	1 A	12 A	—	—	Varies	1 A
Inrush Current Control	✓		✓	✓		✓	
Adjustable Current Limit	✓	✓	✓	✓	✓	✓	
Reverse Current Blocking	✓	✓	✓	✓	✓		
Analog Current Monitoring			✓	✓		✓	
Digital Current Monitoring				✓			
Short-Circuit Protection		✓	✓	✓		✓	
Overvoltage Protection			✓	✓		✓	
Reverse-Polarity Protection			✓	✓	✓	✓	
Power-Good Signal	✓		✓	✓		✓	
Inductive-Load Compatibility						✓	✓
Load-Dump Compatibility				✓	✓	✓	✓
Thermal Shutdown	✓	✓	✓	✓		✓	

Power Switches

Selection Guide

Load Switches

Part Number	V _{IN} (min) (V)	V _{IN} (max) (V)	I _{MAX} (A)	R _{ON} (typ) (mΩ)	Number of Channels	Shutdown Current (ISD) (typ) (μA)	Soft Start	Rise Time (typ) (μs)	Features	Operating Temperature Range (°C)	Package Group	Automotive Grade
TPS22810	2.7	18	3	79	1	0.5	Adjustable Rise Time	115	Quick Output Discharge, Thermal Shutdown, Under Voltage Lock Out	-40 to 105	SOT-23, WSON	✓
TPS22901	1	3.6	0.5	83	1	0.88	Fixed Rise Time	25	N/A	-40 to 85	DSBGA	
TPS22902B	1	3.6	0.5	83	1	0.88	Fixed Rise Time	146	Quick Output Discharge	-40 to 85	DSBGA	
TPS22908	1	3.6	1	30	1	1	Fixed Rise Time	105	Quick Output Discharge	-40 to 85	DSBGA	
TPS22915B	1.05	5.5	2	38	1	0.5	Fixed Rise Time	89	Quick Output Discharge	-40 to 85	DSBGA	
TPS22916C	1.0	5.5	2	60	1	0.01	Fixed Rise Time	900	Quick Output Discharge, Reverse Current Protection, Small package size: 0.78mm x 0.78mm	-40 to 85	DSBGA	
TPS22917	1.0	5.5	2	80	1	0.010	Adjustable Rise Time	88	Quick Output Discharge	-40 to 125	SOT-23	
TPS22918	1.0	5.5	2	52	1	0.5	Adjustable Rise Time	135	Quick Output Discharge	-40 to 105	SOT-23	✓
TPS22925	0.65	3.6	3	10.3	1		Fixed Rise Time		Quick Output Discharge, Reverse Current Protection	-40 to 105	DSBGA	
TPS22953	0.7	5.7	5	14	1	0.01	Adjustable Rise Time	140	Automatic Restart, Power Good, Reverse Current Protection, Thermal Shutdown, Under Voltage Lock Out, Vbias	-40 to 105	WSON	
TPS22954	0.7	5.7	5	14	1	0.01	Adjustable Rise Time	140	Automatic Restart, Power Good, Quick Output Discharge, Thermal Shutdown, Under Voltage Lock Out, Vbias	-40 to 105	WSON	
TPS22959	0.8	5.5	15	4.4	1	1.1	Fixed Rise Time	2663	Quick Output Discharge, Vbias	-40 to 85	WSON	
TPS22963C	1	5.5	3	13.8	1	0.76	Fixed Rise Time	890	Reverse Current Protection	-40 to 85	DSBGA	
TPS22964C	1	5.5	3	13.8	1	0.76	Fixed Rise Time	890	Quick Output Discharge, Reverse Current Protection	-40 to 85	DSBGA	
TPS22968	0.8	5.5	4	25	2	0.5	Adjustable Rise Time	65	Quick Output Discharge, Reverse Current Protection, Vbias	-40 to 105	WSON	✓
TPS22970	0.65	3.6	4	4.7	1	1	Fixed Rise Time	985	Quick Output Discharge, Thermal Shutdown	-40 to 85	DSBGA	
TPS22971	0.65	3.6	3	6.7	1	1.1	Adjustable Rise Time	35	Power Good, Quick Output Discharge, Thermal Shutdown	-40 to 85	DSBGA	
TPS22975	0.6	5.7	6	16	1	2.3	Adjustable Rise Time	140	Quick Output Discharge, Thermal Shutdown, Vbias	-40 to 105	WSON	
TPS22976	0.6	5.7	6	14	2	0.005	Adjustable Rise Time	149	Quick Output Discharge, Reverse Current Protection, Thermal Shutdown, Vbias	-40 to 105	WSON	
TPS22990	0.6	5.5	10	3.9	1	5	Adjustable Rise Time	30.5	Power Good, Quick Output Discharge, Vbias	-40 to 105	WSON	

New devices are listed in bold red.

Power Muxes

Device	IN1, IN2 Input Voltage (min) (V)	IN1, IN2 Input Voltage (max) (V)	IN1 Output Current (max) (A)	IN2 Output Current (max) (A)
TPS2113A	2.8	5.5	1.25, 2.0	1.25, 2.0
TPS2115A	2.8	5.5	1.25, 2.0	1.25, 2.0

eFuses (Integrated FET)

Device	Description	V _{IN} (min) (V)	V _{IN} (max) (V)	Current Limit (min) (A)	Current Limit (max) (A)	Features	UL Recognition	Operating Temperature Range (°C)	Package Group	Automotive Grade
TPS24750/1	18-V, 12-A, 3-mΩ with IMON and PG	2.5	18	0.01	12	Current Sense/Monitor, Fault Reporting, Overvoltage Protection, Power Good, Reverse Current Protection, Thermal Shutdown, Under Voltage Lock Out	No	-40 to 125	WQFN	
TPS25921A/L	18-V, 1.6-A, 90-mΩ with Adjustable ±2% Accurate Current Limit	4.5	18	0.4	1.6	Fault Reporting, Overvoltage Protection, Thermal Shutdown, Under Voltage Lock Out	Yes	-40 to 85	SOIC	
TPS25940	18-V, 5-A, 42-mΩ with Integrated Reverse Current Protection and DevSleep Support	2.7	20	0.6	5.3	Current Sense/Monitor, Fault Reporting, Overvoltage Protection, Power Good, Power MUXing, Reverse Current Protection, Thermal Shutdown, Under Voltage Lock Out	Yes	-40 to 125	WQFN	✓
TPS25942A	18-V, 5-A, 42-mΩ Current Limiting Power MUX w/Integrated Reverse Current Protection, IMON & PG	2.7	18	0.6	5.2	Current Sense/Monitor, Fault Reporting, Overvoltage Protection, Power Good, Power MUXing, Reverse Current Protection, Thermal Shutdown, Under Voltage Lock Out	Yes	-40 to 125	WQFN	
TPS25942L	18-V, 5-A, 42-mΩ Current Limiting Power MUX w/Integrated Reverse Current Protection, IMON & PG	2.7	18	0.6	5.2	Current Sense/Monitor, Fault Reporting, Overvoltage Protection, Power Good, Power MUXing, Reverse Current Protection, Thermal Shutdown, Under Voltage Lock Out	Yes	-40 to 125	WQFN	

New devices are listed in bold red.

Power Switches

Selection Guide

eFuses (Integrated FET) (Continued)

Device	Description	V _{IN} (min) (V)	V _{IN} (max) (V)	Current Limit (min) (A)	Current Limit (max) (A)	Features	UL Recognition	Operating Temperature Range (°C)	Package Group	Automotive Grade
TPS25944A	18-V, 5-A, 42-mΩ Circuit Breaking Power MUX w/Integrated Reverse Current Protection, IMON & PG	2.7	18	0.6	5.2	Current Sense/Monitor, Fault Reporting, Overvoltage Protection, Power Good, Power MUXing, Reverse Current Protection, Thermal Shutdown, Under Voltage Lock Out	Yes	-40 to 125	WQFN	
TPS25944L	18-V, 5-A, 42-mΩ Circuit Breaking Power MUX w/Integrated Reverse Current Protection, IMON & PG	2.7	18	0.6	5.2	Current Sense/Monitor, Fault Reporting, Overvoltage Protection, Power Good, Power MUXing, Reverse Current Protection, Thermal Shutdown, Under Voltage Lock Out	Yes	-40 to 125	WQFN	
TPS2595xx	12-V eFuse With Overvoltage Protection	2.7	18	0.5	4		Yes	-40 to 125	WSON	
TPS2660x	60-V, 2-A Industrial eFuse With Integrated Reverse-Input Polarity Protection	4.2	55	0.1	2.23	Adjustable Rise Time, Analog IMON Output, Current Sense/Monitor, Fault Reporting, Low Iq Shutdown, No RSENSE Required, No Reverse Current When Off, Output Clamp, Over Current Reporting, Over Temp Reporting, Overvoltage Protection, Power MUXing, Reverse Current Blocking, Reverse Current Protection, Thermal Shutdown, Undervoltage Protection, dV/dT	Yes	-40 to 125	HTSSOP, VQFN	
TPS2662x	60-V, 2-A Industrial eFuse With Integrated Input and Output Reverse-Input Polarity Protection	4.2	57	0.025	0.870	Adjustable Rise Time, Analog IMON Output, Current Sense/Monitor, Fault Reporting, Low Iq Shutdown, No RSENSE Required, No Reverse Current When Off, Output Clamp, Over Current Reporting, Over Temp Reporting, Overvoltage Protection, Power MUXing, Reverse Current Blocking, Reverse Current Protection, Thermal Shutdown, Undervoltage Protection, dV/dT	Yes	-40 to 125	HTSSOP, VQFN	

New devices are listed in bold red.

Hot-Swap Selection Tree

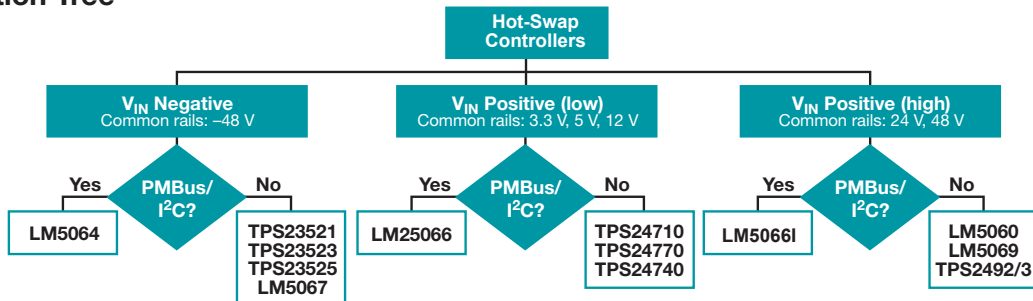

Hot-Swap Controllers

Device	Common Rails (V)	V _{IN} (min) (V)	V _{IN} (max) (V)	Current-Limit Function Enabled	PMBus/i ² C	Features	Operating Temperature Range (°C)	Automotive Grade	Package Group
Negative V_{IN} (Common rails: -48 V)									
LM5064	-48	-80	-10	Always	✓	6% ILIM, -100 V (abs max), UV/OV: 2.8%, IGATE = 52 μA, SOA protection	-40 to 125		HTSSOP
LM5067	-48	-80	-9	Always		-10 V to -80 V, HS, SOA	-40 to 125		SOIC, VSSOP
TPS23521	-48	-80	-10	Always		HS, -200 V (abs max), UV/OV: 1.5%, IGATE = 400 μA, dual ILIM, SS disconnect	-40 to 125		TSSOP
TPS23523	-48	-80	-10	Always		HS + 10R, -200 V (abs max), UV/OV: 1.5%, IGATE = 400 μA, dual ILIM, SS disconnect	-40 to 125		TSSOP
TPS23525	-48	-80	-10	Always		HS + 20R, -200 V (abs max), UV/OV: 1.5%, IGATE = 400 μA, dual ILIM, SS disconnect	-40 to 125		TSSOP
Positive V_{IN} (Low common rails: 3.3 V, 5 V, 12 V)									
LM25066A	3.3, 5, 12	2.9	17	Always	✓	2.9 V to 17 V, HS, SOA	-40 to 125		WQFN
TPS24710	3.3, 5, 12	2.5	18	Startup Only		2.5 V to 18 V, programmable ILIM, SOA	-40 to 85		VSSOP
TPS24740	3.3, 5, 12	2.5	18	Startup Only		2.5 V to 18 V, HP, HS, ideal diode	-40 to 125		VQFN
TPS24770	3.3, 5, 12	2.5	18	Startup Only		2.5 V to 18 V, HP, HS, SOA, IMON	-40 to 125		VQFN
Positive V_{IN} (High common rails: 24 V, 48 V)									
LM5060	24, 48	5.5	65	Startup Only		5.5 V to 65 V, low I _Q	-40 to 125	✓	VSSOP
LM5066I	24, 48	10	80	Always	✓	10 V to 80 V, HS, SOA	-40 to 125		HTSSOP
LM5069	24, 48	9	80	Always		10 V to 80 V, HS, SOA	-40 to 125		VSSOP
TPS2492	24, 48	9	80	Always		9 V to 80 V, HP, HS, SOA, IMON	-40 to 125		TSSOP
TPS2493	24, 48	9	80	Always		9 V to 80 V, HP, HS, SOA, IMON	-40 to 125		TSSOP

New devices are listed in bold red.

Power Switches

Selection Guide

Ideal Diode/ORing Controllers

Device	V _{IN} (min) (V)	V _{IN} (max) (V)	V _{absmin} (min) (V)	I _Q (typ) (mA)	Operating Temperature Range (°C)	Package Group	Automotive Grade
LM74700-Q1	3	65	-65	0.03	-40 to 125	SOT-23	✓
LM74610-Q1	0.48	No Limit	-45	0	-40 to 125	VSSOP	✓
LM5051	36	100	-100	0.69	-40 to 125	SOIC	
LM5050-1	5	75	-0.3	0.40	-40 to 125	SOT-23-THIN	✓
TPS2419	0.8	16.5	-0.3	1.2	-40 to 85	SOIC, TSSOP	

New devices are listed in bold red.

Smart High-Side Switches

Device	V _{CC} (min) (V)	V _{CC} (max) (V)	Number of Channels	R _{ON} at 25°C (typ) (mΩ)	Features	Operating Temperature Range (°C)	Automotive Grade
TPS27S100	3.5	40	1	80	Current Sense Output, Digital Output, Programmable Current Limit, Thermal Shutdown, Undervoltage Lock Out	-40 to 125	
TPS1HA08-Q1	3	40	1	8	Current Sense Output, Programmable Current Limit, Thermal Shutdown, Undervoltage Lock Out	-40 to 125	✓
TPS2HB08-Q1	3	40	2	8	Current Sense Output, Programmable Current Limit, Thermal Shutdown, Undervoltage Lock Out	-40 to 125	✓
TPS2HB16-Q1	3	40	2	16	Current Sense Output, Programmable Current Limit, Thermal Shutdown, Undervoltage Lock Out	-40 to 125	✓
TPS2HB35-Q1	3	40	2	35	Current Sense Output, Programmable Current Limit, Thermal Shutdown, Undervoltage Lock Out	-40 to 125	✓
TPS2HB50-Q1	3	40	2	50	Current Sense Output, Programmable Current Limit, Thermal Shutdown, Undervoltage Lock Out	-40 to 125	✓
TPS1H100-Q1	3.5	40	1	80	Current Sense Output, Digital Output, Programmable Current Limit, Thermal Shutdown, Undervoltage Lock Out	-40 to 125	✓
TPS2H160-Q1	3.4	40	2	160	Current Sense Output, Digital Output, Programmable Current Limit, Thermal Shutdown, Undervoltage Lockout	-40 to 125	✓
TPS4H160-Q1	3.4	40	4	160	Current Sense Output, Digital Output, Programmable Current Limit, Thermal Shutdown, Undervoltage Lockout	-40 to 125	✓
TPS1H200-Q1	3.4	40	1	200	Digital Output, Programmable Current Limit, Thermal Shutdown	-40 to 125	✓
TPS2H000-Q1	3.4	40	2	1000	Current Sense Output, Digital Output, Programmable Current Limit, Thermal Shutdown, Undervoltage Lockout	-40 to 125	✓
TPS4H000-Q1	3.4	40	4	1000	Current Sense Output, Digital Output, Programmable Current Limit, Thermal Shutdown, Undervoltage Lockout	-40 to 125	✓
TPS1H000-Q1	3.4	40	1	1000	Digital Output, Programmable Current Limit, Thermal Shutdown	-40 to 125	✓

New devices are listed in bold red.

Low-Side Switches

Device	Drivers Per Package	Switching Voltage (max) (V)	Peak Output Current (mA)	Output Voltage (max) (V)	I _{OUT/CH} (max) (mA)	Package(s)	Automotive Grade
TPL7407LA	7	30	500	32	600	TSSOP	
ULN2003A	7	50	500	50	500	PDIP, SOIC, TSSOP	
ULN2803A	8	50	500	50	500	SOIC	
ULQ2003A-Q1	7	50	500	50	500	SOIC, TSSOP	✓

New devices are listed in bold red.

DDR Memory Power Solutions

Application and Selection Guide

TI DDR Power Application

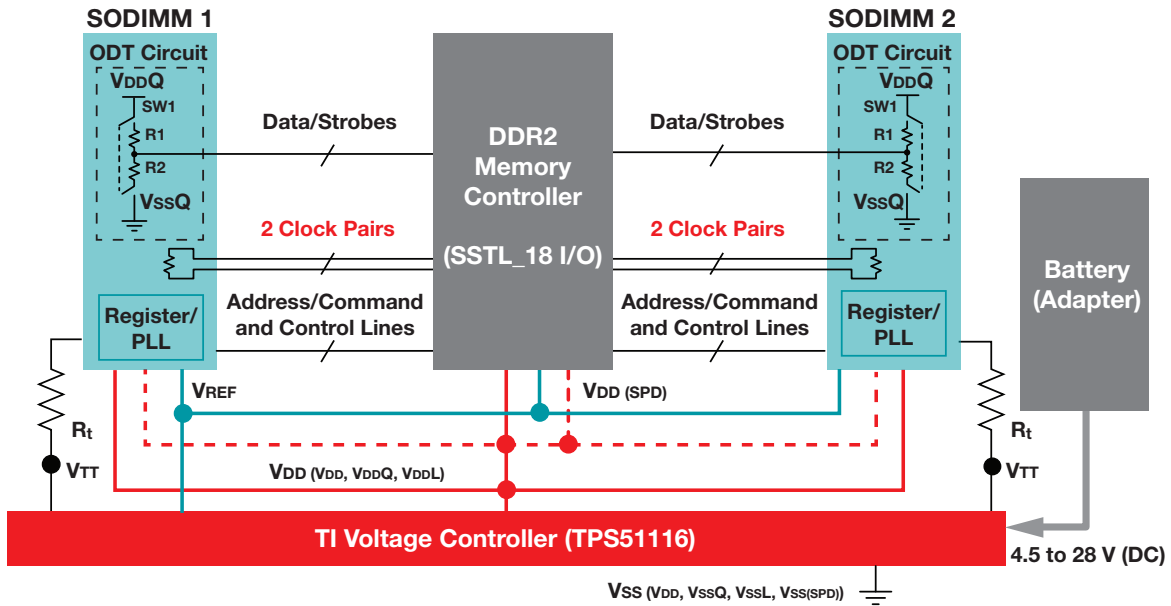

DDR Memory Power Solutions

Device	V _{IN} (V)	I _{OUT} (A)	Provides	DDR Type	Automotive Grade
Plug-in Modules					
PTH03010/50/60W	2.95 to 3.65	6/10/15	VTT	1, 2, 3	
PTH05010/50/60W	4.5 to 5.5	6/10/15	VTT	1, 2, 3	
PTH12010/50/60L	10.8 to 13.2	6/10/12	VTT	1, 2, 3	
Controllers					
TPS40042	2.25 to 5.5	Up to 15	VTT	1, 2, 3, 4, LV3, LP3	
TPS40057	8 to 40	Up to 20	VTT	1, 2, 3	
TPS53647	4.5 to 17	Up to 240	VDDQ	1, 2, 3, 4, LV3, LP3	
TPS40425/8	4.5 to 20	Up to 40	VDDQ	1, 2, 3, 4, LV3, LP3	
Controller + LDO					
TPS51116/59116, TPS51216/716/916	3 to 28 ¹	Up to 25 A for VDDQ, 3 (2-A VTT for TPS51216/916)	VTT, VDDQ, VREF	1, 2, 3, 4, LV3, LP3	
Dual Controller					
TPS51020	4.5 to 28	Up to 15	VTT, VDDQ, VREF	1, 2	
Termination Voltage (Source and Sink) LDOs					
TPS51100	1.2 to 3.6 ²	Up to 3	VTT, VREF	1, 2, 3, 4, LV3, LP3	
TPS51200	1.1 to 3.5 ³	Up to 3	VTT, VREF	1, 2, 3, 4, LV3, LP3	✓
TPS51206	VTT+0.4 V to 3.5 V	Up to 2	VTT, VREF	1, 2, 3, 4, LV3, LP3	
LP2995	2.2 to 5.5	1.5	VTT, VREF	1	
LP2996	1.8 to 5.5	1.5	VTT, VREF	1, 2	
LP2996A	1.5 to 5.5	1.5	VTT, VREF	1, 2, 3	
LP2997	1.8 to 5.5	0.5	VTT, VREF	1, 2	
LP2998	1.35 to 5.5	1.5	VTT, VREF	1, 2, 3	✓
Switchers with Integrated FETs					
TPS54372/672	3 to 6	3/6	VTT	1, 2, 3	✓
TPS53317/A	3 to 6	6	VTT	1, 2, 3, 4, LV3, LP3, LP4	
TPS54972	3 to 4	9	VTT	1, 2, 3	
TPS51362/7	3 to 22 ¹	10/12	VDDQ	1, 2, 3, LV3, LP3	
TPS560200	4.5 to 17	0.5	VPP	4	
TPS54116-Q1	2.95 to 6	4/1	VTT, VDDQ, VREF	1, 2, 3, LV3, LP4	✓

¹Needs 4.5- to 5.5-V bias.

²Needs 4.75- to 5.25-V bias.

³Needs 2.4- to 3.5-V bias.

Voltage References

Overview and Selection Guide

Voltage References

TI's broad voltage-reference portfolio offers performance features such as low-temperature coefficients, precise initial accuracy, low noise, and excellent

long-term stability. Series and shunt references support a wide variety of applications, including high-precision references for data converters with up to 20-bit precision accuracy and

low-noise references for sensor conditioning. Voltage references are also commonly used as voltage monitors, current limiters, and programmable current sources.

Voltage References

Device	Output Voltage (V)	Adjustable	Initial Accuracy (%)	Temp Drift (ppm/°C)	I _Q (typ) (µA)	Package	Automotive Grade	Price*
Shunt V_{REF}								
ATL431/2 B/A	2.5	Up to 36 V	0.5 / 1	92	20	3SOT-23		0.16
REF1112	1.25	—	0.2	50	1.2	3SOT-23		0.85
TL431/2 B/A/Std	2.5	Up to 36 V	0.5 / 1 / 2	92	400	3SOT-23, 5SOT-23, 8SOIC, 8PDIP, 8SOP	✓	0.06
TLV431 B/A/Std	1.24	Up to 6 V	0.5 / 1 / 1.5	138	55	3SOT-23, 5SOT-23, 3SOT-89, 3TO-92	✓	0.15
TLVH431/2 B/A/Std	1.24	Up to 18 V	0.5 / 1 / 1.5	138	60	6SC-70, 3SOT-23, 5SOT-23, 3SOT-89, 3TO-92	✓	0.18
LM4040/1 A/B/C/D	1.225, 2.048, 2.5, 3.0, 4.096, 5.0, 8.192, 10.0	Up to 10 V	0.1 / 0.2 / 0.5 / 1	100	60	SC-70, 3SOT-23, 3TO-92	✓	0.31
LM4050/1 A/B/C	1.225, 2.048, 2.5, 4.096, 5.0, 8.192, 10.0	Up to 10 V	0.1 / 0.2 / 0.5	50	60	3SOT-23	✓	0.75
Series V_{REF}								
REF50xx High/A	2.048, 2.5, 3.0, 4.096, 4.5, 5.0, 10.0	—	0.05 / 1	3 / 8	800	8SOIC, 8VSSOP	✓	1.35
REF34xx	2.5, 3.0, 3.3, 4.096, 5.0	—	0.05	6	72	6SOT-23	✓	1.25
REF33xx	1.25, 1.8, 2.048, 2.5, 3.0, 3.3	—	0.15	30	3.9	3SC-70, 3SOT-23, uQFN-8		0.68
REF20xx	2.5/1.25, 3/1.5, 3.3/1.65, 4.096/2.048	—	0.05	8	360	5SOT-23		1.40
REF30xx	1.25, 2.048, 2.5, 3.0, 3.3, 4.096	—	0.2	75	42	3SOT-23		0.48
REF31xx	1.25, 2.048, 2.5, 3.0, 3.3, 4.096	—	0.2	20	100	3SOT-23	✓	0.99
LM4120 A/Std	1.8, 2.048, 2.5, 3.0, 3.3, 4.096, 5	—	0.2 / 0.5	50	160	5SOT-23		0.70
LM4128 A/B/C/D	1.8, 2.048, 2.5, 3.0, 3.3, 4.096	—	0.1 / 0.2 / 0.5 / 1	75	60	5SOT-23	✓	0.68
LM4132 A/B/C/D	1.8, 2.048, 2.5, 3.0, 3.3, 4.096	—	0.05 / 0.1 / 0.2 / 0.4	20	60	5SOT-23	✓	0.85

*Suggested resale price in U.S. dollars in quantities of 1,000.

Resources

Device Index

Device	Page	Device	Page	Device	Page	Device	Page	Device	Page
ATL431/2 B/A	.84	bq24350	.31	bq27421	.29	CSD16340Q3	.34	CSD19506KCS	.35
bq2000/T	.29	bq24351	.31	bq27426	.29	CSD16415Q5	.34	CSD19506KTT	.35
bq2002/C/E/F	.28	bq24352	.31	bq27441	.29	CSD16556Q5B	.34	CSD19531KCS	.35
bq2004/E/H	.28	bq24380	.31	bq27520	.29	CSD16570Q5B	.34	CSD19531Q5A	.34
bq2005	.28	bq24381	.31	bq2753x	.29	CSD17313Q2	.33	CSD19532KTT	.35
bq2022A	.31	bq24382	.31	bq27542-G1	.29	CSD17318Q2	.33	CSD19532Q5B	.34
bq2024	.31	bq24400/1	.28	bq27546-G1	.29	CSD17381F4	.33	CSD19533KCS	.35
bq2026	.31	bq24450	.28	bq27621	.29	CSD17382F4	.33	CSD19533Q5A	.34
bq2028	.31	bq24600	.27	bq27742-G1	.29	CSD17483F4	.33	CSD19534KCS	.35
bq2031	.28	bq24610	.27	bq27750	.29	CSD17484F4	.33	CSD19534Q5A	.34
bq20z655-R1	.30	bq24616	.27	bq28z610	.30	CSD17556Q5B	.34	CSD19535KCS	.35
bq24030/31/35	.26	bq24617	.27	bq29200	.31	CSD17570Q5B	.34	CSD19535KTT	.35
bq24032A/38	.26	bq24618	.27	bq29209	.31	CSD17571Q2	.33	CSD19536KCS	.35
bq24040/41	.26	bq24620	.28	bq29209-Q1	.31	CSD17573Q5B	.34	CSD19536KTT	.35
bq24045	.26	bq24630	.28	bq2945xy	.31	CSD17575Q3	.34	CSD19537Q3	.34
bq24050/52	.26	bq24640	.28	bq2946xy	.31	CSD17576Q5B	.34	CSD19538Q2	.33
bq24072/72T	.26	bq24650	.29	bq2947xy	.31	CSD17577Q3A	.34	CSD19538Q3A	.34
bq24073	.26	bq24707A	.27	bq2961xy	.31	CSD17577Q5A	.34	CSD22202W15	.36
bq24074	.26	bq24715	.27	bq297xy	.31	CSD17578Q3A	.34	CSD22204W	.36
bq24075T/79T	.26	bq24725A	.27	bq2980	.31	CSD17578Q5A	.34	CSD22205L	.36
bq24090/91	.26	bq24735	.27	bq33100	.30	CSD17579Q3A	.34	CSD22206W	.36
bq24092/93	.26	bq24765	.29	bq34110	.30	CSD17579Q5A	.34	CSD23202W10	.36
bq24095	.26	bq24770	.27	bq34z100-G1	.30	CSD17581Q3A	.34	CSD23203W	.36
bq24130	.27	bq24773	.27	bq4050	.30	CSD17581Q5A	.34	CSD23280F3	.36
bq24133	.27	bq24780S	.27	bq40z50-R2	.30	CSD17585F5	.33	CSD23285F5	.36
bq24157	.26	bq25040	.27	bq76200	.30	CSD18502KCS	.35	CSD23381F4	.36
bq24158	.26	bq25050	.27	bq76920	.30	CSD18503KCS	.35	CSD23382F4	.36
bq24160/A	.26	bq25060	.27	bq76925	.30	CSD18504KCS	.35	CSD25202W15	.36
bq24161/B	.27	bq25070	.28	bq76930	.30	CSD18510Q5B	.34	CSD25211W1015	.36
bq24163	.27	bq25071	.28	bq76940	.30	CSD18511KCS	.35	CSD25213W10	.36
bq24165	.27	bq25100	.27	bq76PL455A	.30	CSD18511KTT	.35	CSD25304W1015	.36
bq24166	.27	bq25100A	.27	bq76PL455A-Q1	.30	CSD18511Q5A	.34	CSD25310Q2	.36
bq24170	.27	bq25100H	.27	bq76PL536A	.30	CSD18512Q5B	.34	CSD25402Q3A	.36
bq24171	.27	bq25101	.27	bq76PL536A-Q1	.30	CSD18513Q5A	.34	CSD25404Q3	.36
bq24172	.27	bq25120A	.26	bq7716xy	.31	CSD18514Q5A	.34	CSD25480F3	.36
bq24190	.27	bq25504	.29	bq7718xy	.31	CSD18531Q5A	.34	CSD25481F4	.36
bq24192	.27	bq25505	.29	bq77PL900	.30	CSD18532KCS	.35	CSD25483F4	.36
bq24192L	.27	bq25570	.29	bq78350-R1	.30	CSD18532NQ5B	.34	CSD25484F4	.36
bq24193	.27	bq25600	.28	bq78z100	.30	CSD18532Q5B	.34	CSD25485F5	.36
bq24195	.27	bq25600C	.28	bq79606-Q1	.30	CSD18533KCS	.35	CSD25501F3	.36
bq24195L	.27	bq25600D	.28	BUF08630	.66	CSD18533Q5A	.34	CSD75207W15	.36
bq24196	.27	bq25601	.28	BUF08821	.66	CSD18534KCS	.35	CSD75208W1015	.36
bq24210	.29	bq25606	.28	BUF12800	.66	CSD18534Q5A	.34	CSD83325L	.33
bq24232	.27	bq25703A	.27	BUF16821	.66	CSD18535KCS	.35	CSD85301Q2	.33
bq24232H	.27	bq25871	.28	BUF16821-Q1	.66	CSD18535KTT	.35	CSD85302L	.33
bq24250	.27	bq25872	.28	BUF20800	.66	CSD18536KCS	.35	CSD86311W1723	.33
bq24253	.27	bq25890	.28	BUF20800-Q1	.66	CSD18536KTT	.35	CSD86330Q3D	.37
bq24295	.27	bq25892	.28	BUF22821	.66	CSD18537NKCS	.35	CSD86350Q5D	.37
bq24296	.27, 28	bq25895	.28, 29	CSD13202Q2	.33	CSD18537NQ5A	.34	CSD86360Q5D	.37
bq24297	.27	bq25896	.28	CSD13302W	.33	CSD18540Q5B	.34	CSD87313DMS	.34
bq24300/5	.31	bq25898	.28	CSD13306W	.33	CSD18541F5	.33	CSD87330Q3D	.37
bq24308	.31	bq25898C	.28	CSD13380F3	.33	CSD18542KTT	.35	CSD87331Q3D	.37
bq24311	.31	bq25898D	.28	CSD13381F4	.33	CSD18543Q3A	.34	CSD87333Q3D	.37
bq24312	.31	bq25910	.28	CSD13383F4	.33	CSD18563Q5A	.34	CSD87334Q3D	.37
bq24313	.31	bq25970	.28	CSD13385F5	.33	CSD19501KCS	.35	CSD87335Q3D	.37
bq24314/A	.31	bq26100	.31	CSD15380F3	.33	CSD19502Q5B	.34	CSD87350Q5D	.37
bq24314C	.31	bq27220	.29	CSD15571Q2	.33	CSD19503KCS	.35	CSD87351Q5D	.37
bq24315	.31	bq27320	.29	CSD16301Q2	.33	CSD19505KCS	.35	CSD87351ZQ5D	.37
bq24316	.31	bq27411	.29	CSD16327Q3	.34	CSD19505KTT	.35	CSD87352Q5D	.37

Resources

Device Index

Device	Page	Device	Page	Device	Page	Device	Page	Device	Page
CSD87353Q5D	37	LM(2)5119	15	LM2773	16	LM36273	67	LM5046	44, 45, 48
CSD87355Q5D	37	LM(2)5141	14	LM2775	19	LM36274	67	LM5050-1	82
CSD87381P	37	LM(2)5145	14	LM2776	21	LM3630A	67	LM5051	82
CSD87384M	37	LM1770	8	LM27761	21	LM3631	68	LM5056	78
CSD87501L	33	LM1771	8	LM27762	20, 21	LM3632A	68	LM5060	81
CSD87502Q2	33	LM20123/33/43	7	LM2830	7	LM3633	68	LM5064	78, 81
CSD87503Q3E	34	LM20124/34/44/54	8	LM2831	7	LM3642	64	LM5066	78
CSD87588N	37	LM20125/45	8	LM2832	7	LM3643	64	LM5066i	78, 81
CSD88537ND	33	LM20136/46	8	LM2833	7	LM3644	64	LM5067	81
CSD88539ND	33	LM21212-1	8	LM2852	7	LM3644TT	64	LM5069	81
CSD88584Q5DC	37	LM21212-2	8	LM2853	8	LM3646	64	LM5100A/B/C	40
CSD88599Q5DC	37	LM21215	8	LM2854	8	LM3648	64	LM5101A/B/C	40
CSD95372AQ5M	37	LM21215A	8	LM2936	4	LM3648TT	64	LM5104	40
CSD95372BQ5M	37	LM21305	10	LM3000	15	LM3668	20	LM5105	40
CSD95372BQ5MC	37	LM22674/75/76/77	12	LM3152	14	LM3670	7	LM5106	40
CSD95373AQ5M	37	LM25011	12	LM3153	14	LM3671	7	LM5109B	40
CSD95373BQ5M	37	LM25019/18/17	12	LM317L-N	4	LM3691	7	LM5110	39
CSD95375Q4M	37	LM25037	44, 45, 47	LM3281	7	LM36922	68	LM5111	39
CSD95377Q4M	37	LM25056/A	78	LM3401	62	LM36922H	68	LM5112	38, 39
CSD95378BQ5M	37	LM25066/A	78	LM3402/02HV	62	LM36923	68	LM5114A/B	39
CSD95378BQ5MC	37	LM25066A	81	LM3404/04HV	62	LM36923H	68	LM5118	19
CSD95379Q3M	37	LM25066I/A	78	LM3405/05A	62	LM3697	68	LM5121	18
CSD95472Q5MC	37	LM25118	19	LM3406HV-Q1	56	LM3704	69, 71	LM5122	18
CSD95480RWJ	37	LM25122-Q1	18	LM3409/09HV-Q1	56	LM3710	69, 71	LM5134	39
CSD95481RWJ	37	LM2574/75/76	12	LM3414/14HV	62	LM3724	69, 70	LM5140	15
CSD95482RWJ	37	LM2574HV/75HV/76HV	12	LM3421-Q1	56	LM3754	14, 15	LM5150-Q1	18
CSD95490Q5MC	37	LM2591HV/92HV	12	LM3423-Q1	56	LM3880	71	LM5160/A	12
CSD95491Q5MC	37	LM2594/95/96	12	LM3424-Q1	56	LM3881	71	LM5161	12
CSD95492QVM	37	LM2611	20	LM3429-Q1	56	LM4040/1	84	LM5165	12
CSD95495QVM	37	LM2623	17, 18	LM3444	63	LM4050/1	84	LM5166	12
CSD95496QVM	37	LM2642	15	LM3445	63	LM4120	84	LM5170-Q1	19
CSD96370Q5M	37	LM26420	13	LM3447	63	LM4128	84	LM5175	19, 20
CSD96371Q5M	37	LM2647	15	LM3450/50A	63	LM4132	84	LM5176	19, 20
CSD97370AQ5M	37	LM2650	9	LM3463	62	LM43600/01/02/03	11	LM53600/1-Q1	11
CSD97370Q5M	37	LM2651	9	LM3464/64A	62	LM46000/01/02	12	LM53602/3-Q1	11
CSD97394Q4M	37	LM2653	9	LM3466	62	LM5000	18	LM53625/35-Q1	11
CSD97395Q4M	37	LM2655	9	LM3477	14	LM5001	17, 18	LM5574/5/6	12
CSD97396Q4M	37	LM2660	21	LM3478	18, 47	LM5005	12	LM5642	15
DLPA1000	54	LM2662/3	16, 21	LM3481	47	LM5006	12	LM5642x	15
EMB1428Q	30	LM2664	19	LM3485	14	LM5007	12	LM73605/6	12
EMB1499Q	30	LM2674/75/76/77	12	LM3489	14	LM5008/A	12	LM74610-Q1	82
INA210	78	LM2717	13	LM34919/B/C	11	LM5009/A	12	LM74700-Q1	82
INA219	78	LM2717-ADJ	13	LM3528	67	LM5010/A	12	LM76002/3	12
INA226	78	LM27313	18	LM3530	67	LM5019/18/17	12	LM809	69, 70
INA230	78	LM2733	18	LM3532	67	LM5020	18, 20, 47	LM810	69, 70
INA282	78	LM2734	9	LM3535	67	LM5021	45, 47	LM8342	66
ISO5451	41	LM27341	9	LM3537	67	LM5022	18, 47	LM8364	69, 70
ISO5452	41	LM27342	9	LM3538	67	LM5023	45, 46	LM8365	69, 70
ISO5452-Q1	43	LM2735	18	LM3550	64	LM5025/A/B/C	48	LM8502	68
ISO5500	41	LM2736	9	LM3554	64	LM5026	44, 45, 48	LMC6953	69, 71
ISO5851	41	LM2738	9	LM3555	64	LM5030	44, 45, 47	LMC7660	21
ISO5852S	42	LM27402	14	LM3556	64	LM5032	47	LMG1020	50, 52
ISO5852S-Q1	43	LM27403	14	LM3559	64	LM5033	44, 47	LMG1210	50, 52
LM(2)5085/A	14	LM2742	14	LM3560	64	LM5034	44, 45, 48	LMG3410	50-52
LM(2)5088	14	LM2743	14	LM3561	64	LM5035/B/C	48	LMG5200	50-52
LM(2)5115/A	14, 48	LM2755	60	LM3565	64	LM5036	48	LMP8640	78
LM(2)5116	14	LM2756	68	LM36010	64	LM5039	44, 45, 48	LMP8645	78
LM(2)5117	14	LM2771	16	LM36011	64	LM5041/A/B	47	LMP8646	78
LM(2)5118	20	LM2772	16	LM36272	67	LM5045	44, 45, 48	LMR10510	7

Resources

Device Index

Device	Page	Device	Page	Device	Page	Device	Page	Device	Page
LMR10515	7	LP5523	60	PTH08T220/221W	23	TLC5916-Q1	59	TLV8x3	70
LMR10520	7	LP55231	60	PTH08T230/231W	23	TLC5917-Q1	59	TLVH431/2	84
LMR12007	9	LP5524	60	PTH08T240/241W	23	TLC59208F	60	TPD2S300	76
LMR12010	9	LP55281	60	PTH08T240F	23	TLC5921	61	TPD6S300	76
LMR14006	11	LP5560	60	PTH08T250/255W	23	TLC59210	61	TPD8S300	76
LMR14010A	11	LP5562	60	PTH08T260/261W	23	TLC5922	61	TPIC2810	59
LMR14020/30/50	12	LP5569	60	PTH12000L/W	23	TLC5923	61	TPIC6C596	59
LMR14020-Q1	12	LP5907	4	PTH12010/50/60L	83	TLC5924	61	TPIC74100-Q1	19, 20
LMR14030-Q1	12	LP5907-Q1	5	PTH12010L/W	23	TLC5925	61	TPIC74101-Q1	20
LMR14050-Q1	12	LP5910	4	PTH12010Y	24	TLC5926-Q1	59	TPL7407LA	82
LMR14203/06	11	LP5912	4	PTH12020L/W	23	TLC5927-Q1	59	TPS1H000-Q1	82
LMR16006	12	LP5912-Q1	5	PTH12030L/W	23	TLC59281	61	TPS1H100-Q1	82
LMR16010/20/30	12	LP8501	60	PTH12040W	23	TLC59283	61	TPS1H200-Q1	82
LMR23610/25/30	11	LP8543	67	PTH12050L/W	23	TLC5929	61	TPS1HA08-Q1	82
LMR23615/25/30	11	LP8545	67	PTH12050Y	24	TLC59401	61	TPS2000C	74
LMR33620/30	11	LP8550	67	PTH12060L/W	23	TLC5941	61	TPS2001D	74
LMR36006/15	12	LP8553	67	PTH12060Y	24	TLC5941-Q1	59	TPS2002C	74
LMR70503	17, 19	LP8556	67	PTN04050C	24	TLC5946	61	TPS2003C	74
LMS33460	70	LP8557	67	PTN78000W/H	24	TLC5947	61	TPS2020	74
LMS3635/55-Q1	11	LP87524B-Q1	53	PTN78020W/H	24	TLC5948A	61	TPS2021	74
LMZ10500/1	24	LP8758-B0	8	PTN78060W/H	24	TLC5949	61	TPS2022	74
LMZ10503/04/05	24	LP8860	67	PTR08060W	24	TLC5951	61	TPS2023	74
LMZ12001/02/03	24	LP8861	67	PTR08100W	24	TLC5954	61	TPS2024	74
LMZ12001/02/03EXT	24	LP8862	67	PTV03010W	24	TLC5955	61	TPS2030	74
LMZ12008/10	25	LP8863	67	PTV03020W	24	TLC59581	61	TPS2031	74
LMZ13608/10	25	MC33063A2	18	PTV05010W	24	TLC5960	60, 68	TPS2032D	74
LMZ14201H/02H/03H	25	MC34063A	19	PTV05020W	24	TLC5973	60	TPS2033D	74
LMZ20501/2	24	MCP809	69, 70	PTV08T250W	24	TLC59731	60	TPS2034D	74
LMZ21700/1	24	PTH03000W	23	PTV12010L/W	24	TLC6C5712-Q1	59	TPS2034P	74
LMZ22003/5	25	PTH03010/50/60W	83	PTV12020L/W	24	TLC6C5716-Q1	59	TPS2041B	74
LMZ223603/5	25	PTH03010W	23	REF1112	84	TLC6C5724-Q1	59	TPS2041C	74
LMZ223608/10	25	PTH03010Y	24	REF20xx	84	TLC6C5816-Q1	59	TPS2042B	75
LMZ30602/4/6	24	PTH03020W	23	REF30xx	84	TLC6C5912	60	TPS2043B	75
LMZ31503/6	24	PTH03030W	23	REF31xx	84	TLC6C5912-Q1	59	TPS2044B	75
LMZ31520/30	25	PTH03050W	23	REF33xx	84	TLC6C598	60	TPS2045A	74
LMZ31704/7/10	25	PTH03050Y	24	REF34xx	84	TLC6C598-Q1	59	TPS2046B	75
LMZ34002	25	PTH03060W	23	REF50xx	84	TLV431B/A/Std	84	TPS2047B	75
LMZ34202	25	PTH03060Y	24	REG710	21	TLV61046A	17, 18	TPS2048A	75
LMZ35003	25	PTH04000W	23	REG71050	21	TLV62080	7	TPS2049D	74
LMZ36002	25	PTH04040W	23	REG711	21	TLV62084A	7	TPS2051B	74
LMZM23600/1	25	PTH04070W	23	SG2524	47	TLV62085	8	TPS2052B	75
LMZM33602/3	25	PTH04T220/221W	23	SM72295	40	TLV62090	8	TPS2053B	75
LP2985-N	4	PTH04T230/231W	23	SM72442	20	TLV62095	8	TPS2054B	75
LP2995	83	PTH04T240/241W	23	SM72445	20	TLV62130A	9	TPS2055A	74
LP2996	83	PTH04T260/261W	23	SM72482	39	TLV62150	9	TPS2056A	75
LP2996A	83	PTH05000W	23	SM74101	39	TLV62568	7	TPS2057A	75
LP2997	83	PTH05010/50/60W	83	SM74104	40	TLV62569	7	TPS2058A	75
LP2998	83	PTH05010W	23	TCA6507	68	TLV62585	8	TPS2060C	74
LP38798	4	PTH05010Y	24	TL2842B/3B/4B/5B	47	TLV702-Q1	5	TPS2061D	74
LP3943	60	PTH05020W	23	TL431/2	84	TLV704	4	TPS2062A	75
LP3944	60	PTH05030W	23	TL494	45, 47	TLV705	4	TPS2062C	74
LP3950	60	PTH05050W	23	TL497A	19	TLV711	4	TPS2062D	75
LP3952	60	PTH05050Y	24	TL499A	19	TLV733P-Q1	5	TPS2063D	75
LP3954	60	PTH05060W	23	TL594	45, 47	TLV742P	4	TPS2064C	74
LP5018	60	PTH05060Y	24	TLC59108	60	TLV755P	4	TPS2065C	74
LP5024	60	PTH05T210W	23	TLC59108F	60	TLV757P	4, 5	TPS2065D	74
LP5520	60	PTH08000W	23	TLC59116	60	TLV760	4	TPS2066A	75
LP5521	60	PTH08080W	23	TLC59116F	60	TLV809	70	TPS2066C	74
LP5522	60	PTH08T210W	23	TLC59116-Q1	59	TLV810	69, 70	TPS2066D	75

Resources

Device Index

Device	Page	Device	Page	Device	Page	Device	Page	Device	Page
TPS2067D	75	TPS2511/Q100	76	TPS2HB08-Q1	82	TPS40042	14, 83	TPS53353	11
TPS2068C	74	TPS2513/14	76	TPS2HB16-Q1	82	TPS40057	83	TPS53355	11
TPS2068D	74	TPS2513A/3AQ100/4A	76	TPS2HB35-Q1	82	TPS40075	14	TPS53513	10
TPS2069C	74	TPS2513A/4A/3AQ1/4A-Q1	76	TPS2HB50-Q1	82	TPS40077	14	TPS53515	11
TPS2113A	80	TPS25200	75	TPS3103	69, 71	TPS40100	14	TPS53622	16
TPS2115A	80	TPS25221	75	TPS3106	69, 71	TPS40101	14	TPS53625	16
TPS22810	80	TPS2530BV	74	TPS3110	69, 71	TPS40132	15	TPS53626	16
TPS22901	80	TPS2540/1	76	TPS3123	69, 70	TPS40140	15	TPS53631	16
TPS22902B	80	TPS2540A/1A	76	TPS3124	69, 70	TPS40170	14	TPS53640	16
TPS22908	80	TPS2543/-Q1	76	TPS3125	69, 70	TPS40180	15	TPS53640A	16
TPS22915B	80	TPS2543/Q100	76	TPS3126	70	TPS40190	14	TPS53641	16
TPS22916C	80	TPS2544	76	TPS3128	70	TPS40192/3	14	TPS53647	15, 83
TPS22917	80	TPS2546	76	TPS3305	69, 71	TPS40195	14	TPS53659	16
TPS22918	80	TPS2546/-Q1	76	TPS3306	71	TPS40200	14	TPS53661	16
TPS22925	80	TPS2547	76	TPS3307	69, 71	TPS40210	18, 47	TPS53667	15
TPS22953	80	TPS2549/49-Q1	76	TPS3510/1	71	TPS40303/4/5	14	TPS53679	16
TPS22954	80	TPS254900-Q1	76	TPS3513/4	71	TPS40322	15	TPS53681	15
TPS22959	80	TPS2551	75	TPS3600	69, 71	TPS40345	14	TPS53819A	14
TPS22963C	80	TPS2552	75	TPS3606-33	71	TPS40400	14	TPS53915	11
TPS22964C	80	TPS2552D	75	TPS3613-01	71	TPS40422	15	TPS5402	9
TPS22968	80	TPS2553-1	75	TPS3617/8	69, 71	TPS40425	15, 83	TPS54020	10
TPS22970	80	TPS2553D	75	TPS3619/20	69, 71	TPS40425/8	15, 83	TPS5403/05	9
TPS22971	80	TPS2554	75	TPS3700	69, 70	TPS43060	18	TPS54040A/140A/240	12
TPS22975	80	TPS2555	75	TPS3701	69, 70	TPS43330A-Q1	53	TPS54060A/160A/260	12
TPS22976	80	TPS2556	75	TPS3702	69, 70	TPS43340-Q1	53	TPS54061	12
TPS22990	80	TPS2557	75	TPS3705	71	TPS43350-Q1	53	TPS54062	12
TPS23521	81	TPS2559	75	TPS3707	69, 71	TPS4H000-Q1	82	TPS5410/20/30/50	12
TPS23523	81	TPS2560A	75	TPS3710	69, 70	TPS4H160-Q1	82	TPS54116-Q1	83
TPS23525	81	TPS2561A	75	TPS3711	69, 70	TPS51020	83	TPS54202	9
TPS2372-3/-4	73	TPS25740B	76	TPS3779/80	69, 70	TPS51100	83	TPS54202H	9
TPS2372-4	72, 73	TPS25810	76	TPS3803	69, 70	TPS51116/59116	83	TPS54218	7
TPS2373-3/-4	73	TPS25820	76	TPS3805	69, 70	TPS51200	83	TPS54231/2/3	9
TPS2373-4	72, 73	TPS25921A/L	80	TPS3806	69, 70	TPS51206	83	TPS54239/239E	9
TPS23750/70	73	TPS25940	80	TPS3807	69, 71	TPS51216/716/916	83	TPS54283/6	13
TPS23751/2	72, 73	TPS25942A	80	TPS3808	69, 70	TPS51220A	15	TPS54290/1/2	13
TPS23753A	72, 73	TPS25942L	80	TPS3809	69, 70	TPS51225/B/C	15	TPS54294/5	13
TPS23754	72, 73	TPS25944A	81	TPS3813	69, 70	TPS51275/B/C	15	TPS54302/08	10
TPS23754/6	73	TPS25944L	81	TPS3820/8	70	TPS51285A/B	15	TPS54318	8
TPS23757	73	TPS2595xx	81	TPS3823	70	TPS51362	10, 83	TPS54319	8
TPS2376-H	72, 73	TPS2660x	81	TPS3824	69, 70	TPS51362/7	83	TPS54320	9
TPS2378	72, 73	TPS2662x	81	TPS3825	69, 70	TPS51363	10	TPS54331	10
TPS2379	73	TPS27S100	82	TPS3831	69, 70	TPS51367	11	TPS54332	10
TPS2384	73	TPS2811	39	TPS3836/8	69, 70	TPS51611	15	TPS54335-1A/-2A	10
TPS23861	72, 73	TPS2812	39	TPS3837	69, 70	TPS51622A	16	TPS54335A	10
TPS2388	72, 73	TPS2813	39	TPS3839	69, 70	TPS51623	16	TPS54336A	10
TPS23880	72, 73	TPS2814	39	TPS3847	69, 70	TPS51624	16	TPS54339/339E	10
TPS2419	82	TPS2815	39	TPS3850	69, 70	TPS51631/A	15	TPS54340/540	12
TPS24710	81	TPS2816	39	TPS3851	69, 70	TPS51633	16	TPS54341/541	12
TPS24740	81	TPS2817	39	TPS3852	69, 70	TPS51678	16	TPS54360/560	12
TPS24750/1	80	TPS2818	39	TPS386000	69, 71	TPS53014/15	14	TPS54361/561	12
TPS24770	81	TPS2819	39	TPS3860x0	71	TPS53119	15	TPS54372/672	83
TPS2480/1	78	TPS28225	40	TPS386596	69, 71	TPS53125/6/7	14	TPS54388-Q1	8
TPS2482/3	78	TPS28225-Q1	43	TPS3890	69, 70	TPS53128/29	15	TPS54424	10
TPS2492	81	TPS28226	40	TPS3895/7	69, 70	TPS53211	15	TPS54427/8	10
TPS2493	81	TPS2833	40	TPS3896/8	69, 70	TPS53219A	15	TPS54478	8
TPS2500	75	TPS2837	40	TPS40000	14	TPS53311	8	TPS54494/5	13
TPS2501	75	TPS2849	40	TPS40007/9	14	TPS53313	10	TPS544B20	11
TPS2505	75	TPS2H000-Q1	82	TPS40040	14	TPS53316	8	TPS544B25	11
TPS2511/-Q1	76	TPS2H160-Q1	82	TPS40041	14	TPS53317/A	83	TPS544C20	11

Resources

Device Index

Device	Page	Device	Page	Device	Page	Device	Page	Device	Page
TPS544C25	.11	TPS60230	.68	TPS61195	.67	TPS62690	.7	TPS65170	.65
TPS54519	.8	TPS60240	.16, 21	TPS61196	.67	TPS62730	.7	TPS65175/C	.65
TPS54521	.10	TPS6024x	.19	TPS61197	.68	TPS62740	.7	TPS65176	.65
TPS54527/8	.10	TPS60250/5	.68	TPS61199	.67	TPS62743/431	.7	TPS65177A	.65
TPS54531	.10	TPS60251	.68	TPS61200	.18	TPS62745	.9	TPS65178	.65
TPS54618-Q1	.8	TPS6031x	.19	TPS61220	.18	TPS62746	.7	TPS65185	.54
TPS54622	.10	TPS60400	.16, 21	TPS61230	.18	TPS62748	.7	TPS65186	.66
TPS54627/8	.10	TPS60401	.21	TPS61230A	.17, 18	TPS62750	.7	TPS65192	.66
TPS54678	.8	TPS60402	.21	TPS61236P	.18	TPS62770	.13	TPS65193	.66
TPS546C20A/23	.11	TPS60403	.21	TPS61240	.17, 18	TPS62801	.7	TPS65194	.66
TPS54719	.8	TPS60500	.16	TPS61252	.18	TPS62821	.7	TPS65196	.66
TPS54821	.10	TPS61020	.17, 18	TPS61253A	.17, 18	TPS62822	.7	TPS65197	.66
TPS54824	.10	TPS61021A	.17, 18	TPS61256C	.18	TPS62823	.8	TPS65198	.66
TPS548A20	.11	TPS61022	.18	TPS61259	.17, 18	TPS62825	.7	TPS65217	.54
TPS548D22	.11	TPS61029	.17, 18	TPS61260	.18	TPS62826	.7, 8	TPS65218D0	.54
TPS54917	.8	TPS61030	.18	TPS61280A	.17, 18	TPS63000	.20	TPS65250	.13
TPS54972	.83	TPS61040	.17, 18, 67	TPS61291	.17, 18	TPS63010	.20	TPS65251	.13
TPS549A20	.11	TPS61041	.67	TPS61300	.64	TPS63020	.20	TPS652510	.13
TPS54A20	.10	TPS61042	.67	TPS61310	.64	TPS63024	.20	TPS65251-1/-2/-3	.13
TPS55065-Q1	.19, 20	TPS61043	.67	TPS61322x	.17, 18	TPS630250	.20	TPS65257	.13
TPS55165-Q1	.20	TPS61045	.67	TPS61325	.64	TPS63027	.20	TPS65261/-1	.13
TPS5516x-Q1	.19	TPS61046	.18, 67	TPS61500	.68	TPS63030	.20	TPS65262/-1	.13
TPS55332-Q1	.17, 18	TPS61050	.64	TPS62050	.9	TPS63050	.20	TPS65263	.13
TPS55340	.17, 18	TPS61060	.67	TPS62060	.7	TPS63060	.20	TPS65263-1Q1	.13
TPS55383/6	.13	TPS61061	.67	TPS62065	.7	TPS63070	.20	TPS65263Q1	.13
TPS560200	.9, 83	TPS61062	.67	TPS62080	.7	TPS63700	.19	TPS65265	.13
TPS561201	.9	TPS6107x	.18	TPS62085	.8	TPS63710	.19	TPS65266/66-1	.13
TPS561208	.9	TPS61081	.17, 18	TPS62088	.8	TPS65000-Q1	.53	TPS65279	.13
TPS56121	.11	TPS61085	.18	TPS62090	.8	TPS65023	.54	TPS65279V	.13
TPS562200/09	.9	TPS61087	.17, 18	TPS62095	.8	TPS650250	.54	TPS65283/65283-1	.13
TPS562201/08	.9	TPS61088	.18	TPS62097	.7	TPS650830	.54	TPS65287	.13
TPS56221	.11	TPS61089	.18	TPS62120	.9	TPS650940	.54	TPS65288	.13
TPS562210A	.9	TPS61090	.18	TPS62125	.9	TPS65100	.65	TPS65311-Q1	.53
TPS562219A	.9	TPS61093	.18	TPS62130A	.10	TPS65100-Q1	.65	TPS65320D-Q1	.53
TPS563200/09	.9	TPS61096A	.18	TPS62135/136	.10	TPS65120	.66	TPS65321A-Q1	.53
TPS563201/08	.9	TPS61097A-33	.17, 18	TPS62140	.9	TPS65130	.20, 66	TPS65381A-Q1	.53, 54
TPS563210A	.9	TPS61098x	.17, 18	TPS62147/148	.9	TPS65131	.20, 66	TPS653850-Q1	.53
TPS563219A	.10	TPS61099x	.17, 18	TPS62150	.9	TPS65131/Q1	.66	TPS65400	.13
TPS564201/08	.10	TPS61120	.19	TPS62160	.9	TPS65131-Q1	.20	TPS65580/1	.13
TPS56428	.10	TPS61121	.19	TPS62170	.9	TPS65132	.20, 66	TPS65631W	.66
TPS56520	.10	TPS61130	.20	TPS62175	.9	TPS65133	.20	TPS65632	.66
TPS565201/8	.10	TPS61140	.67	TPS62180	.10	TPS65135	.20, 66	TPS65642/A	.65
TPS56528	.10	TPS61150A	.67	TPS62184	.10	TPS65140	.65	TPS65680	.66
TPS56628	.10	TPS61160	.67	TPS62230	.7	TPS65140-Q1	.65	TPS659037	.54
TPS56720	.10	TPS61161	.67	TPS62240	.7	TPS65142	.65	TPS659039-Q1	.53
TPS568215/2150A	.10	TPS61163A	.67	TPS62260	.7	TPS65145	.65	TPS65910	.54
TPS56920	.10	TPS61165	.67	TPS62270	.7	TPS65145-Q1	.65	TPS65916	.54
TPS56C20	.11	TPS61166	.67	TPS62290	.7	TPS65146	.65	TPS65917-Q1	.53
TPS56C215	.11	TPS61169	.67	TPS62360	.8	TPS65148	.65	TPS65981	.76
TPS57112-Q1	.7	TPS61170	.17, 18	TPS62366	.8	TPS65149	.65	TPS65986	.76
TPS57114-Q1	.8	TPS61175	.17, 18	TPS62400	.13	TPS65150	.65	TPS65990	.76
TPS59124	.15	TPS61176	.67	TPS62410	.13	TPS65150-Q1	.65	TPS68470	.54
TPS59610	.15	TPS61177	.68	TPS62420	.13	TPS65154	.65	TPS706	.4
TPS59620	.15	TPS61178	.17, 18	TPS62480	.8	TPS65160/A	.65	TPS709	.4
TPS59621	.15	TPS61183	.67	TPS62510	.7	TPS65161	.65	TPS715A	.4
TPS59640	.15	TPS61185	.67	TPS62619	.7	TPS65161B	.65	TPS717	.4
TPS59641	.15	TPS61187	.68	TPS62620	.7	TPS65162	.65	TPS720	.5
TPS59650	.15	TPS61193	.67	TPS62660	.7	TPS65165	.65	TPS720-Q1	.5
TPS60150	.16, 19	TPS61194	.67	TPS62674	.7	TPS65168	.65	TPS73801	.4

Resources

Device Index

Device	Page	Device	Page	Device	Page	Device	Page	Device	Page
TPS74401	.5	TPS92411	.63	UCC27201A	.42	UCC28089	.47	UCD9090A	.71
TPS75103	.68	TPS92510	.62	UCC27201A-Q1	.43	UCC2809-1-2	.47	UCD90910	.71
TPS781	.4	TPS92511	.62	UCC27210	.40	UCC2810	.47	ULN2003A	.82
TPS782	.4	TPS92512/512HV	.62	UCC27211/A	.40	UCC2813-0/1/2/3/4/5	.47	ULN2803A	.82
TPS797	.4	TPS92513/513HV	.62	UCC27211A-Q1	.42, 43	UCC2817/8/9/A/-1	.48	ULQ2003A-Q1	.82
TPS798-Q1	.5	TPS92515/515HV-Q1	.56	UCC27212	.40	UCC28180	.44, 48		
TPS7A05	.4	TPS92518/HV-Q1	.56	UCC27222	.40	UCC28220	.47		
TPS7A10	.4	TPS92560	.62, 63	UCC27223	.40	UCC28221	.47		
TPS7A16	.4	TPS92561	.63	UCC27321	.39	UCC28230/1	.48		
TPS7A16-Q1	.5	TPS92610-Q1	.57	UCC27321-Q1	.43	UCC28250/1	.48		
TPS7A19	.4	TPS92611-Q1	.57	UCC27322	.39	UCC28500	.48		
TPS7A30	.4	TPS92612-Q1	.57	UCC27323	.39	UCC28503	.48		
TPS7A33	.4	TPS92630-Q1	.57	UCC27324	.39	UCC28510	.48		
TPS7A39	.4	TPS92638-Q1	.57	UCC27325	.39	UCC28517	.48		
TPS7A4001	.4	TPS92640/41	.62	UCC27423	.38, 39	UCC28600	.46		
TPS7A4201	.4	TPS92660	.62	UCC27424	.39	UCC28610	.46		
TPS7A45	.4	TPS92661-Q1	.56	UCC27425	.39	UCC28630/1/2/3/4	.45, 46		
TPS7A47	.4	TPS92662-Q1	.56	UCC27425-Q1	.43	UCC28700/1	.45, 46		
TPS7A49	.4	TPS92691-Q1	.56	UCC27511	.38	UCC28704	.46		
TPS7A52-Q1	.5	TPS92692-Q1	.56	UCC27511A-Q1	.43	UCC28710/1/2	.45, 46		
TPS7A66-Q1	.5	TPS92830-Q1	.57	UCC27512	.38	UCC28720	.46		
TPS7A8101-Q1	.5	TPSM82480	.24	UCC27516	.38	UCC28722	.46		
TPS7A83A	.4, 5	TPSM84203/05/12	.9	UCC27517A	.38, 43	UCC28730	.45, 46		
TPS7A85A	.5	TPSM84209	.24	UCC27518	.38	UCC28740	.45, 46		
TPS7A88	.4, 5	TPSM84424	.24	UCC27519	.38	UCC28780	.45, 46		
TPS7A88-Q1	.5	TPSM846C23	.25	UCC27519A-Q1	.43	UCC28810/1	.48		
TPS7A90	.4	TPSM846C24	.25	UCC27523	.38	UCC28880	.49		
TPS7A91	.5	TPSM84824	.25	UCC27524A	.38, 43	UCC28881	.49		
TPS7A92	.4	TPSM84A21/2	.25	UCC27524A-Q1	.43	UCC2891	.48		
TPS7B4250-Q1	.5	UC2524A	.47	UCC27525	.38	UCC28910	.49		
TPS7B4253-Q1	.5	UC2525A	.47	UCC27526	.38	UCC28911	.49		
TPS7B4254-Q1	.5	UC2526A	.47	UCC27527	.39	UCC2892	.48		
TPS7B63-Q1	.5	UC28023	.47	UCC27528	.38	UCC2893	.48		
TPS7B68-Q1	.5	UC28025	.47	UCC27528-Q1	.43	UCC2894	.48		
TPS7B69	.4	UC2825	.47	UCC27531	.38, 42	UCC28950	.44, 45, 48		
TPS7B69-Q1	.5	UC2825A/B	.47	UCC27531D	.42	UCC28951	.48		
TPS7B7701-Q1	.5	UC2827-1	.47	UCC27531-Q1	.38, 43	UCC2897A	.44, 45, 48		
TPS7B7702-Q1	.5	UC2827-2	.47	UCC27532	.38	UCC28C40/1/2/3/4/5	.47		
TPS7B82-Q1	.5	UC2842A/3A/4A/5A	.47	UCC27533	.38	UCC2946	.69		
TPS81256	.24	UC2846	.47	UCC27536	.38	UCC29910A	.48		
TPS82084	.22, 24	UC2853A	.48	UCC27537	.39	UCC29950	.44, 48		
TPS82085	.24	UC2856	.47	UCC27538	.39	UCC37321	.38, 39		
TPS82130	.22, 24	UC3823A/B	.47	UCC27611	.39	UCC37322	.39		
TPS82140	.24	UCC2/3946	.70	UCC27710	.40	UCC3884	.47		
TPS82150	.24	UCC21222-Q1	.42, 43	UCC27712	.40, 42	UCC5310	.41		
TPS82671	.24	UCC21225A	.42	UCC27712-Q1	.42, 43	UCC5320	.41		
TPS8268180	.24	UCC21520	.42	UCC27714	.40	UCC5350	.41		
TPS82693	.24	UCC21520-Q1	.43	UCC2800/1/2/3/4/5	.47	UCC5350SB	.41		
TPS82695	.24	UCC24610	.49	UCC28019A	.44, 48	UCC5390	.41		
TPS82740A	.24	UCC24612	.49	UCC28050/1	.48	UCD3138	.49, 52		
TPS82740B	.24	UCC24630	.49	UCC28056	.48	UCD3138A	.49		
TPS92023	.63	UCC24636	.49	UCC28060/1	.48	UCD7100PWP	.39		
TPS92074	.63	UCC25600	.44, 45, 48, 68	UCC2806	.47	UCD7138	.44, 49		
TPS92075	.63	UCC256301/2/3/4	.48	UCC28063/A	.48	UCD7201PWP	.39		
TPS92210	.63	UCC25701/2	.48	UCC28064	.48	UCD90120A	.71		
TPS92310	.63	UCC25705/6	.48	UCC28070/A	.48	UCD90124A	.71		
TPS92314/14A	.63	UCC25710	.68	UCC2807-1-2-3	.47	UCD90160A	.71		
TPS92315	.63	UCC27200/A	.40	UCC2808-1/-2/A-1/A-2	.47	UCD90240	.71		
TPS92410	.63	UCC27201A	.40	UCC28083/4/5/6	.47	UCD90320	.71		

Fundamentals of Power Supply Design

Topics include:

- Voltage regulation
- Power supply components
- Switching power topologies
- Control algorithms
- Feedback loop compensation
- Magnetic component design
- Controlling electromagnetic noise
- Designing for higher efficiency
- Digital power control
- Power supply construction

Order your copy today: www.ti.com/powersupplybook

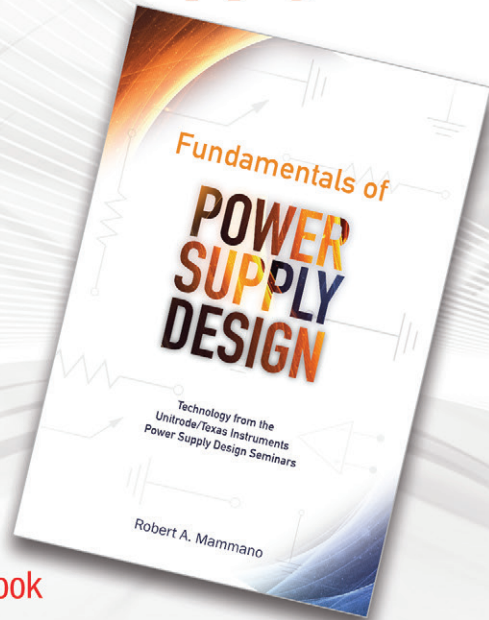

Solve design issues

Analog Design Journal

“How to” articles written **by** engineers **for** engineers



www.ti.com/adj

Power Stage Designer™

The easiest tool to **create** and **optimize** your power supply design

www.ti.com/powerstage-designer

The screenshot displays the Power Stage Designer software interface. On the left, there is a 'Design Values' panel with input fields for Minimum input Voltage (9 V), Maximum input Voltage (36 V), Output Voltage (5 V), Output Current (4 A), Switching Frequency (200 kHz), Diode Voltage Drop (0.7 V), Current Ripple (66%), and Maximum Duty Cycle (56%). Below these are radio buttons for conduction modes: Discontinuous Conduction Mode, Boundary Mode, Continuous Conduction Mode (selected), and Transition Mode. The central part of the interface shows a circuit diagram of a flyback converter with components labeled Ci, Q1, Np, Ns, D1, and Co. On the right, there are 'Recommended Values' and 'Calculated Values at Input Voltage: 9.00 V' sections. The calculated values include: Switch. Freq.: 200.00 kHz, Input Power: 22.80 W, Output Power: 20.00 W, Duty Cycle: 55.88%, On-Time: 2.79 µs, Off-Time: 2.21 µs, Zero-Time: 0.00 µs, RHPZ: 11.09 kHz, Load Current: 4.00 A, Input Current: 2.53 A, Current Ripple: 1.01 A, and Diode Losses: 2.80 W. An 'Info' button is located at the bottom right of the calculated values section.

TI Worldwide Technical Support

TI Support

Thank you for your business. Find the answer to your support need or get in touch with our support center at

www.ti.com/support

China:

<http://www.ti.com.cn/guidedsupport/cn/docs/supporthome.jsp>

Japan:

<http://www.tij.co.jp/guidedsupport/jp/docs/supporthome.jsp>

Technical support forums

Search through millions of technical questions and answers at TI's E2E™ Community (engineer-to-engineer) at

e2e.ti.com

China:

<http://www.deyisupport.com/>

Japan:

<http://e2e.ti.com/group/jp/>

TI Training

From technology fundamentals to advanced implementation, we offer on-demand and live training to help bring your next-generation designs to life. Get started now at

training.ti.com

China:

<http://www.ti.com.cn/general/cn/docs/gencontent.jsp?contentId=71968>

Japan:

<https://training.ti.com/jp>

Important Notice: The products and services of Texas Instruments Incorporated and its subsidiaries described herein are sold subject to TI's standard terms and conditions of sale. Customers are advised to obtain the most current and complete information about TI products and services before placing orders. TI assumes no liability for applications assistance, customer's applications or product designs, software performance, or infringement of patents. The publication of information regarding any other company's products or services does not constitute TI's approval, warranty or endorsement thereof.

B011617

Trademarks: The platform bar, Auto-Track, C2000, D-CAP, D-CAP+, D-CAP2, D-CAP3, DCS-Control, DualCool, E2E, EasyScale, Eco-mode, HotRod, iHVM, Impedance Track, MicroSiP, MSP430, my.TI, NexFET, POLA, PowerPAD, PowerStack, Power Stage Designer, Predictive Gate Drive, SafeTI, SDQ, SWIFT, TurboTrans and ULQ are trademarks and SIMPLE SWITCHER and WEBENCH are registered trademarks of Texas Instruments. ARM7 and Cortex are trademarks and ARM is a registered trademark of ARM Limited. E Ink and Vizplex are registered trademarks of E Ink Corporation. PMBus is a trademark of SMIF, Inc. USB Type-C is a trademark of the USB Implementers Forum. All other trademarks are the property of their respective owners.

IMPORTANT NOTICE FOR TI DESIGN INFORMATION AND RESOURCES

Texas Instruments Incorporated ("TI") technical, application or other design advice, services or information, including, but not limited to, reference designs and materials relating to evaluation modules, (collectively, "TI Resources") are intended to assist designers who are developing applications that incorporate TI products; by downloading, accessing or using any particular TI Resource in any way, you (individually or, if you are acting on behalf of a company, your company) agree to use it solely for this purpose and subject to the terms of this Notice.

TI's provision of TI Resources does not expand or otherwise alter TI's applicable published warranties or warranty disclaimers for TI products, and no additional obligations or liabilities arise from TI providing such TI Resources. TI reserves the right to make corrections, enhancements, improvements and other changes to its TI Resources.

You understand and agree that you remain responsible for using your independent analysis, evaluation and judgment in designing your applications and that you have full and exclusive responsibility to assure the safety of your applications and compliance of your applications (and of all TI products used in or for your applications) with all applicable regulations, laws and other applicable requirements. You represent that, with respect to your applications, you have all the necessary expertise to create and implement safeguards that (1) anticipate dangerous consequences of failures, (2) monitor failures and their consequences, and (3) lessen the likelihood of failures that might cause harm and take appropriate actions. You agree that prior to using or distributing any applications that include TI products, you will thoroughly test such applications and the functionality of such TI products as used in such applications. TI has not conducted any testing other than that specifically described in the published documentation for a particular TI Resource.

You are authorized to use, copy and modify any individual TI Resource only in connection with the development of applications that include the TI product(s) identified in such TI Resource. NO OTHER LICENSE, EXPRESS OR IMPLIED, BY ESTOPPEL OR OTHERWISE TO ANY OTHER TI INTELLECTUAL PROPERTY RIGHT, AND NO LICENSE TO ANY TECHNOLOGY OR INTELLECTUAL PROPERTY RIGHT OF TI OR ANY THIRD PARTY IS GRANTED HEREIN, including but not limited to any patent right, copyright, mask work right, or other intellectual property right relating to any combination, machine, or process in which TI products or services are used. Information regarding or referencing third-party products or services does not constitute a license to use such products or services, or a warranty or endorsement thereof. Use of TI Resources may require a license from a third party under the patents or other intellectual property of the third party, or a license from TI under the patents or other intellectual property of TI.

TI RESOURCES ARE PROVIDED "AS IS" AND WITH ALL FAULTS. TI DISCLAIMS ALL OTHER WARRANTIES OR REPRESENTATIONS, EXPRESS OR IMPLIED, REGARDING TI RESOURCES OR USE THEREOF, INCLUDING BUT NOT LIMITED TO ACCURACY OR COMPLETENESS, TITLE, ANY EPIDEMIC FAILURE WARRANTY AND ANY IMPLIED WARRANTIES OF MERCHANTABILITY, FITNESS FOR A PARTICULAR PURPOSE, AND NON-INFRINGEMENT OF ANY THIRD PARTY INTELLECTUAL PROPERTY RIGHTS.

TI SHALL NOT BE LIABLE FOR AND SHALL NOT DEFEND OR INDEMNIFY YOU AGAINST ANY CLAIM, INCLUDING BUT NOT LIMITED TO ANY INFRINGEMENT CLAIM THAT RELATES TO OR IS BASED ON ANY COMBINATION OF PRODUCTS EVEN IF DESCRIBED IN TI RESOURCES OR OTHERWISE. IN NO EVENT SHALL TI BE LIABLE FOR ANY ACTUAL, DIRECT, SPECIAL, COLLATERAL, INDIRECT, PUNITIVE, INCIDENTAL, CONSEQUENTIAL OR EXEMPLARY DAMAGES IN CONNECTION WITH OR ARISING OUT OF TI RESOURCES OR USE THEREOF, AND REGARDLESS OF WHETHER TI HAS BEEN ADVISED OF THE POSSIBILITY OF SUCH DAMAGES.

You agree to fully indemnify TI and its representatives against any damages, costs, losses, and/or liabilities arising out of your non-compliance with the terms and provisions of this Notice.

This Notice applies to TI Resources. Additional terms apply to the use and purchase of certain types of materials, TI products and services. These include; without limitation, TI's standard terms for semiconductor products (<http://www.ti.com/sc/docs/stdterms.htm>), [evaluation modules](#), and [samples](http://www.ti.com/sc/docs/sampterm.htm) (<http://www.ti.com/sc/docs/sampterm.htm>).

Mailing Address: Texas Instruments, Post Office Box 655303, Dallas, Texas 75265
Copyright © 2018, Texas Instruments Incorporated

Looking for pricing, stock, or lifecycle information?

Click below to explore more details on WIN SOURCE:

 [View TPS65149RSHR on WIN SOURCE](#)

 [Texas Instruments](#) Information

Optimize Your Supply Chain with WIN SOURCE Solutions

-  Global Sourcing Solution
-  Obsolete Management
-  Cost Control Management
-  Shortage Management
-  Alternative Solution
-  Excess Inventory Management