



**THE DATASHEET OF
TPS650250RHBR**



TPS650250 Power Management IC (PMIC) for SoCs and Multirail Subsystems

1 Features

- 1.6 A, 97% Efficient Step-Down Converter for System Voltage (VDCDC1)
 - 3.3 V, 2.8 V, or Adjustable
- 0.8 A, up to 95% Efficient Step-Down Converter for Memory Voltage (VDCDC2)
 - 1.8 V, 2.5 V, or Adjustable
- 0.8 A, 90% Efficient Step-Down Converter for Processor Core (VDCDC3)
- Adjustable Output Voltage on VDCDC3
- 30-mA LDO for V_{dd_alive}
- 2 × 200 mA General-Purpose LDOs (LDO1 and LDO2)
- Dynamic Voltage Management for Processor Core
- LDO1 and LDO2 Voltage Externally Adjustable
- Separate Enable Pins for Inductive Converters
- 2.25-MHz Switching Frequency
- 85- μ A Quiescent Current
- Thermal Shutdown Protection

2 Applications

- Cellular, Smart Phones
- GPS
- Digital Still Cameras
- Split Supply DSP and μ P Solutions
- Samsung ARM-Based Processors

3 Description

The TPS650250 device is an integrated power management IC for applications requiring multiple power rails. The TPS650250 provides three highly efficient, step-down converters targeted at providing the core voltage, peripheral, I/O and memory rails in a processor-based system. All three step-down converters, controlled by the MODE pin, enter a low-power mode at light load for maximum efficiency or operate in forced fixed frequency PWM mode.

The TPS650250 device integrates two general-purpose 200-mA LDO voltage regulators. Both LDOs operate with an input voltage range from 1.5 V to 6.5 V, allowing them to be supplied from one of the step-down converters. The output voltage of all rails can be set with an external resistor divider and enabled with an input pin. Additionally, a 30-mA LDO is typically used to provide power to an always-on rail.

Device Information⁽¹⁾

PART NUMBER	PACKAGE	BODY SIZE (NOM)
TPS650250	VQFN (32)	5.00 mm x 5.00 mm

(1) For all available packages, see the orderable addendum at the end of the datasheet.

Detailed Block Diagram

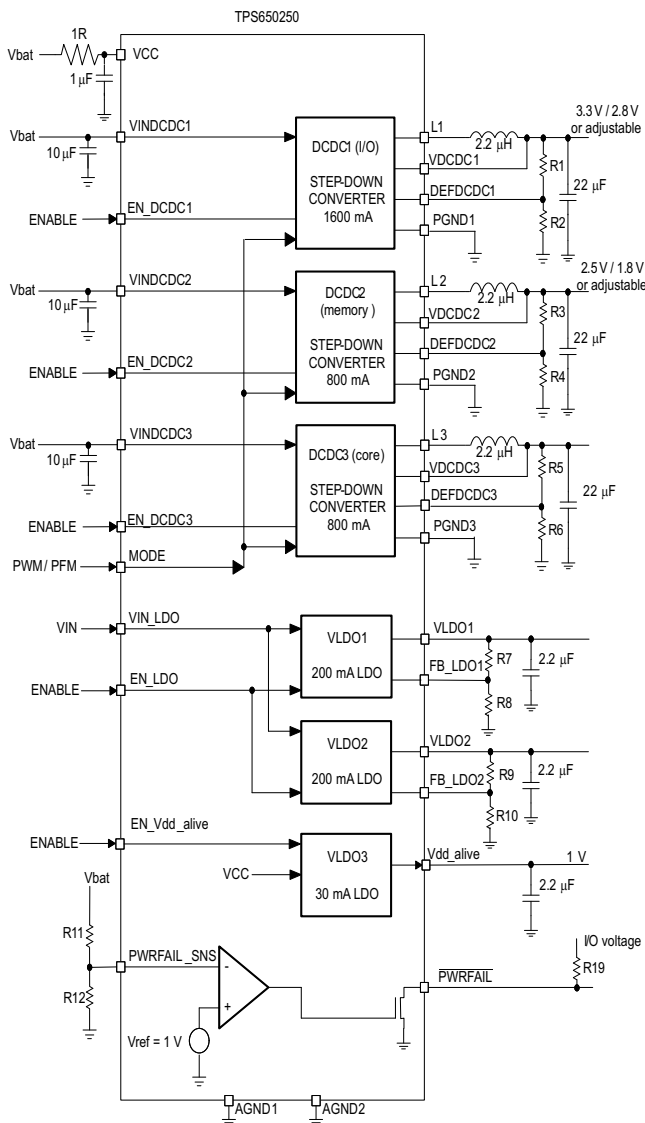

Table of Contents

1 Features	1	7.3 Feature Description	13
2 Applications	1	7.4 Device Functional Modes	15
3 Description	1	8 Application and Implementation	16
4 Revision History	2	8.1 Application Information	16
5 Pin Configuration and Functions	3	8.2 Typical Application	17
6 Specifications	4	9 Power Supply Recommendations	24
6.1 Absolute Maximum Ratings	4	10 Layout	24
6.2 ESD Ratings	4	10.1 Layout Guidelines	24
6.3 Recommended Operating Conditions	5	10.2 Layout Example	25
6.4 Thermal Information	5	11 Device and Documentation Support	26
6.5 Dissipation Ratings	6	11.1 Device Support	26
6.6 Electrical Characteristics	6	11.2 Documentation Support	26
6.7 Electrical Characteristics VDCDC1	8	11.3 Receiving Notification of Documentation Updates	26
6.8 Electrical Characteristics VDCDC2	8	11.4 Community Resources	26
6.9 Electrical Characteristics VDCDC3	9	11.5 Trademarks	26
6.10 Typical Characteristics	10	11.6 Electrostatic Discharge Caution	27
7 Detailed Description	12	11.7 Glossary	27
7.1 Overview	12	12 Mechanical, Packaging, and Orderable Information	27
7.2 Functional Block Diagram	12		

4 Revision History

NOTE: Page numbers for previous revisions may differ from page numbers in the current version.

Changes from Revision A (September 2014) to Revision B	Page
• Changed the title of the data sheet	1
• Changed the <i>Handling Ratings</i> table to <i>ESD Ratings</i> and moved the storage temperature to the <i>Absolute Maximum Ratings</i> table	4
• Added the <i>Development Support</i> , <i>Documentation Support</i> , <i>Receiving Notification of Documentation Updates</i> , and <i>Community Resources</i> sections	26
• Changed the <i>Electrostatic Discharge Caution</i> statement	26

Changes from Original (December 2008) to Revision A	Page
• Added <i>Handling Rating</i> table, <i>Feature Description</i> section, <i>Device Functional Modes</i> , <i>Application and Implementation</i> section, <i>Power Supply Recommendations</i> section, <i>Layout</i> section, <i>Device and Documentation Support</i> section, and <i>Mechanical, Packaging, and Orderable Information</i> section	1

5 Pin Configuration and Functions

**RHB Package
32-Pin VQFN With Exposed Thermal Pad
Top View**

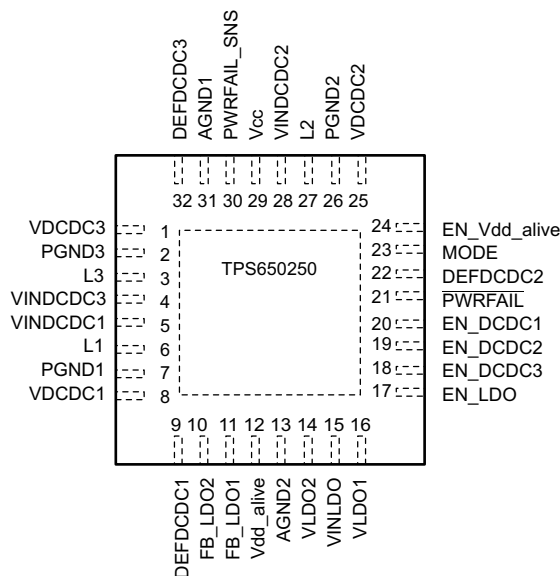

Pin Functions

PIN		I/O	DESCRIPTION
NAME	NO.		
SWITCHING REGULATOR SECTION			
AGND1	31	—	Analog ground connection. All analog ground pins are connected internally on the chip.
AGND2	13	—	Analog ground connection. All analog ground pins are connected internally on the chip.
Thermal pad	—	—	Connect the power pad to analog ground.
VINDCDC1	5	I	Input voltage for VDCDC1 step-down converter. This must be connected to the same voltage supply as VINDCDC2, VINDCDC3 and VCC.
L1	6	—	Switch pin of VDCDC1 converter. The VDCDC1 inductor is connected here.
VDCDC1	8	I	VDCDC1 feedback voltage sense input, connect directly to VDCDC1.
PGND1	7	—	Power ground for VDCDC1 converter.
VINDCDC2	28	I	Input voltage for VDCDC2 step-down converter. This must be connected to the same voltage supply as VINDCDC1, VINDCDC3 and VCC.
L2	27	—	Switch pin of VDCDC2 converter. The VDCDC2 inductor is connected here.
VDCDC2	25	I	VDCDC2 feedback voltage sense input, connect directly to VDCDC2.
PGND2	26	—	Power ground for VDCDC2 converter.
VINDCDC3	4	I	Input voltage for VDCDC3 step-down converter. This must be connected to the same voltage supply as VINDCDC1, VINDCDC2 and VCC.
L3	3	—	Switch pin of VDCDC3 converter. The VDCDC3 inductor is connected here.
VDCDC3	1	I	VDCDC3 feedback voltage sense input, connect directly to VDCDC3.
PGND3	2	—	Power ground for VDCDC3 converter.
Vcc	29	I	Power supply for digital and analog circuitry of DCDC1, DCDC2 and DCDC3 DC-DC converters. This must be connected to the same voltage supply as VINDCDC3, VINDCDC1 and VINDCDC2.
DEFDCDC1	9	I	Input signal indicating default VDCDC1 voltage, 0 = 2.8V, 1 = 3.3V . This pin can also be connected to a resistor divider between VDCDC1 and GND. In this case the output voltage of the DCDC1 converter can be set in a range from 0.6V to VINDCDC1.

Pin Functions (continued)

PIN		I/O	DESCRIPTION
NAME	NO.		
DEFDCDC2	22	I	Input signal indicating default VDCDC2 voltage, 0 = 1.8V, 1 = 2.5V . This pin can also be connected to a resistor divider between VDCDC2 and GND. In this case the output voltage of the DCDC2 converter can be set in a range from 0.6V to VINDCDC2.
DEFDCDC3	32	I	This pin must be connected to a resistor divider between VDCDC3 and GND. The output voltage of the DCDC3 converter can be set in a range from 0.6V to VINDCDC3.
EN_DCDC1	20	I	VDCDC1 enable pin. A logic high enables the regulator, a logic low disables the regulator.
EN_DCDC2	19	I	VDCDC2 enable pin. A logic high enables the regulator, a logic low disables the regulator.
EN_DCDC3	18	I	VDCDC3 enable pin. A logic high enables the regulator, a logic low disables the regulator.
LDO REGULATOR SECTION			
VINLDO	15	I	Input voltage for LDO1 and LDO2.
VLDO1	16	O	Output voltage of LDO1.
VLDO2	14	O	Output voltage of LDO2.
EN_LDO	17	I	Enable input for LDO1 and LDO2. Logic high enables the LDOs, logic low disables the LDOs.
EN_Vdd_alive	24	I	Enable input for Vdd_alive LDO. Logic high enables the LDO, logic low disables the LDO.
Vdd_alive	12	O	Output voltage for Vdd_alive.
FB_LDO1	11	I	Feedback pin for LDO1.
FB_LDO2	10	I	Feedback pin for LDO2.
CONTROL AND I2C SECTION			
MODE	23	I	Select between Power Safe Mode and forced PWM Mode for DCDC1, DCDC2 and DCDC3. In Power Safe Mode PFM is used at light loads, PWM for higher loads. If PIN is set to high level, forced PWM Mode is selected. If Pin has low level, then Device operates in Power Safe Mode.
PWRFAIL	21	O	Open drain output. Active low when PWRFAIL comparator indicates low VBAT condition.
PWRFAIL_SNS	30	I	Input for the comparator driving the /PWRFAIL output.

6 Specifications

6.1 Absolute Maximum Ratings

 over operating free-air temperature range (unless otherwise noted) ⁽¹⁾

		MIN	MAX	UNIT
	Input voltage range on all pins except A/PGND pins with respect to AGND	-0.3	7	V
	Voltage range on pins VLDO1, VLDO2, FB_LDO1, FB_LDO2	-0.3	3.6	V
	Current at VINDCDC1, L1, PGND1, VINDCDC2, L2, PGND2, VINDCDC3, L3, PGND3	2000	2000	mA
	Peak current at all other pins	500	500	mA
	Continuous total power dissipation	See Dissipation Ratings		
T _A	Operating free-air temperature	-40	85	°C
T _J	Maximum junction temperature	125	125	°C
T _{stg}	Storage temperature	-65	150	°C

(1) Stresses beyond those listed under *Absolute Maximum Ratings* may cause permanent damage to the device. These are stress ratings only and functional operation of the device at these or any other conditions beyond those indicated under *Recommended Operating Conditions* is not implied. Exposure to absolute-maximum-rated conditions for extended periods may affect device reliability.

6.2 ESD Ratings

		VALUE	UNIT
V _(ESD)	Electrostatic discharge	Human body model (HBM), per ANSI/ESDA/JEDEC JS-001 ⁽¹⁾	2000
		Charged device model (CDM), per JEDEC specification JESD22-C101 ⁽²⁾	500

(1) JEDEC document JEP155 states that 500-V HBM allows safe manufacturing with a standard ESD control process.

(2) JEDEC document JEP157 states that 250-V CDM allows safe manufacturing with a standard ESD control process.

6.3 Recommended Operating Conditions

		MIN	NOM	MAX	UNIT
V _{CC}	Input voltage range step-down converters, VINDCDC1, VINDCDC2, VINDCDC3	2.5		6.0	V
V _O	Output voltage range for step-down converter, VDCDC1 ⁽¹⁾	0.6		VINDCDC1	V
	Output voltage range for mem step-down converter, VDCDC2 ⁽¹⁾	0.6		VINDCDC2	V
	Output voltage range for core step-down converter, VDCDC3	0.6		VINDCDC3	V
V _I	Input voltage range for LDOs, VINLDO1, VINLDO2	1.5		6.5	V
V _O	Output voltage range for LDOs	1		3.3	V
I _O	Output current at L, V1DCDC1			1600	mA
L1	Inductor at L1 ⁽²⁾	1.5	2.2		μH
C _I	Input capacitor at VINDCDC1 ⁽²⁾	10			μF
C _O	Output capacitor at VDCDC1 ⁽²⁾	10	22		μF
I _O	Output current at L2, VDCDC2			800	mA
L2	Inductor at L2 ⁽²⁾	1.5	2.2		μH
C _I	Input capacitor at VINDCDC2 ⁽²⁾	10			μF
C _O	Output capacitor at VDCDC2 ⁽²⁾	10	22		μF
I _O	Output current at L3, VDCDC3			800	mA
L3	Inductor at L3 ⁽²⁾	1.5	2.2		μH
C _I	Input capacitor at VINDCDC3 ⁽²⁾	10			μF
C _O	Output capacitor at VDCDC3 ⁽²⁾	10	22		μF
C _I	Input capacitor at VCC ⁽²⁾	1			μF
C _I	Input capacitor at VINLDO ⁽²⁾	1			μF
C _O	Output capacitor at VLDO1, VLDO2 ⁽²⁾	2.2			μF
I _O	Output current at VLDO1, VLDO2			200	mA
C _O	Output capacitor at Vdd_alive ⁽²⁾	2.2			μF
I _O	Output current at Vdd_alive			30	mA
T _A	Operating ambient temperature	-40		85	°C
T _J	Operating junction temperature	-40		125	°C
R _{CC}	Resistor from VINDCDC3, VINDCDC2, VINDCDC1 to V _{CC} used for filtering ⁽³⁾		1	10	Ω

(1) When using an external resistor divider at DEFDCDC2, DEFDCDC1.

(2) See applications section for more information, for V_O > 2.85V choose 3.3μH inductor.

(3) Up to 2.5mA can flow into V_{CC} when all 3 converters are running in PWM, this resistor will cause the UVLO threshold to be shifted accordingly.

6.4 Thermal Information

THERMAL METRIC ⁽¹⁾	TPS650250		UNIT
	RHB (VQFN)		
	32 PINS		
R _{θJA}	Junction-to-ambient thermal resistance	31.8	°C/W
R _{θJC(top)}	Junction-to-case (top) thermal resistance	21.8	°C/W
R _{θJB}	Junction-to-board thermal resistance	5.8	°C/W
ψ _{JT}	Junction-to-top characterization parameter	0.2	°C/W
ψ _{JB}	Junction-to-board characterization parameter	5.7	°C/W
R _{θJC(bot)}	Junction-to-case (bottom) thermal resistance	1.3	°C/W

(1) For more information about traditional and new thermal metrics, see the [Semiconductor and IC Package Thermal Metrics application report](#).

6.5 Dissipation Ratings

PACKAGE ⁽¹⁾	R _{θJA}	T _A ≤ 25°C POWER RATING	DERATING FACTOR ABOVE T _A = 25°C	T _A = 70°C POWER RATING	T _A = 85°C POWER RATING
RHB	35 K/W	2.85 W	28m W/K	1.57 W	1.14 W

(1) The thermal resistance junction to ambient of the RHB package is measured on a high K board. The thermal resistance junction to power pad is 1.5k/W.

6.6 Electrical Characteristics

VINDCDC1 = VINDCDC2 = VINDCDC3 = VCC = VINLDO = 3.6V, T_A = –40°C to 85°C, typical values are at T_A = 25°C (unless otherwise noted)

PARAMETER		TEST CONDITIONS	MIN	TYP	MAX	UNIT
CONTROL SIGNALS: EN_DCDC1, EN_DCDC2, EN_DCDC3, EN_LDO, MODE, EN_VDD_ALIVE						
V _{IH}	High level input voltage		1.45		VCC	V
V _{IL}	Low level input voltage		0		0.4	V
I _H	Input bias current			0.01	0.1	μA
SUPPLY PINS: VCC, VINDCDC1, VINDCDC2, VINDCDC3						
I _{q(PFM)}	Operating quiescent current	PFM All 3 DCDC converters enabled, zero load and no switching, LDOs enabled	V _{CC} = 3.6V	135	170	μA
		PFM All 3 DCDC converters enabled, zero load and no switching, LDO1, LDO2 = OFF, Vdd_alive = ON		75	100	
		PFM DCDC1 and DCDC2 converters enabled, zero load and no switching, LDO1, LDO2 = OFF, Vdd_alive = ON		55	80	
		PFM DCDC1 converter enabled, zero load and no switching, LDO1, LDO2 = OFF, Vdd_alive = ON		40	60	
I _{VCC(PWM)}	Current into V _{CC} ; PWM	All 3 DCDC converters enabled & running in PWM, LDOs off	V _{CC} = 3.6V	2		mA
		PWM DCDC1 and DCDC2 converters enabled and running in PWM, LDOs off		1.5	2.5	
		PWM DCDC1 converter enabled and running in PWM, LDOs off		0.85	2	
I _q	Quiescent current	All converters disabled, LDO1, LDO2 = OFF, Vdd_alive = OFF	V _{CC} = 3.6V	16		μA
		All converters disabled, LDO1, LDO2 = OFF, Vdd_alive = ON		26		
VLDO1 AND VLDO2 LOW DROPOUT REGULATORS						
I _q	Operating quiescent current	Current per LDO into VINLDO		16	30	μA
I _(SD)	Shutdown current	Total current into VINLDO, VLDO = 0V		0.6	2	μA
V _I	Input voltage range for LDO1, LDO2		1.5		6.5	V
V _O	LDO1 output voltage range		1		3.3	V
	LDO2 output voltage range		1		3.3	V
VFB	LDO1 and LDO2 feedback voltage			1.0		V
I _O	Maximum output current for LDO1, LDO2	V _I = 1.8V, V _O = 1.3V		200		mA
I _O	Maximum output current for LDO1, LDO2	V _I = 1.5V; V _O = 1.3V		120		mA

Electrical Characteristics (continued)

VINDCDC1 = VINDCDC2 = VINDCDC3 = VCC = VINLDO = 3.6V, T_A = –40°C to 85°C, typical values are at T_A = 25°C (unless otherwise noted)

PARAMETER		TEST CONDITIONS	MIN	TYP	MAX	UNIT	
I _{SC}	LDO1 and LDO2 short circuit current limit	V _{LDO1} = GND, V _{LDO2} = GND			400	mA	
	Minimum voltage drop at LDO1, LDO2	I _O = 50mA, VINLDO = 1.8V			120	mV	
	Minimum voltage drop at LDO1, LDO2	I _O = 50mA, VINLDO = 1.5V		65	150	mV	
	Minimum voltage drop at LDO1, LDO2	I _O = 200mA, VINLDO = 1.8V			300	mV	
	Output voltage accuracy for LDO1, LDO2	I _O = 10mA	–2%		1%		
	Line regulation for LDO1, LDO2	V _{INLDO1,2} = V _{LDO1,2} + 0.5V (min. 2.5V) to 6.5V, I _O = 10mA	–1%		1%		
	Load regulation for LDO1, LDO2	I _O = 0mA to 200mA	–1%		1%		
	Regulation time for LDO1, LDO2	Load change from 10% to 90%		10		μs	
VDD_ALIVE LOW DROPOUT REGULATOR							
V _{dd_alive}	V _{dd_alive} LDO output voltage, TPS6502500 to TPS6502504	I _O = 0mA		1.0		V	
I _O	Output current for V _{dd_alive}				30	mA	
I _(SC)	V _{dd_alive} short circuit current limit	V _{dd_alive} = GND			100	mA	
	Output voltage accuracy for V _{dd_alive}	I _O = 0mA	–1%		1%		
	Line regulation for V _{dd_alive}	V _{CC} = V _{dd_alive} + 0.5 V to 6.5 V, I _O = 0mA	–1%		1%		
	Regulation time for V _{dd_alive}	Load change from 10% to 90%		10		μs	
ANALOGIC SIGNALS DEFDCDC1, DEFDCDC2, DEFDCDC3							
V _{IH}	High level input voltage		1.3		V _{CC}	V	
V _{IL}	Low level input voltage		0		0.1	V	
I _H	Input bias current			0.001	0.05	μA	
THERMAL SHUTDOWN							
T _{SD}	Thermal shutdown	Increasing junction temperature		160		°C	
	Thermal shutdown hysteresis	Decreasing junction temperature		20		°C	
INTERNAL UNDER VOLTAGE LOCK OUT							
UVLO	Internal UVLO	V _{CC} falling	–3%	2.35	3%	V	
V _{UVLO_HYST}	internal UVLO comparator hysteresis			120		mV	
VOLTAGE DETECTOR COMPARATOR							
PWRFAIL_SNS	Comparator threshold	Falling threshold	–2%	1.0	2%	V	
	Hysteresis			40	50	60	mV

Electrical Characteristics (continued)

VINDCDC1 = VINDCDC2 = VINDCDC3 = VCC = VINLDO = 3.6V, T_A = –40°C to 85°C, typical values are at T_A = 25°C (unless otherwise noted)

PARAMETER		TEST CONDITIONS	MIN	TYP	MAX	UNIT
	Propagation delay	25mV overdrive			10	μs
V _{OL}	Power fail output low voltage	I _{OL} = 5 mA			0.3	V

6.7 Electrical Characteristics VDCDC1

VINDCDC1 = VINDCDC2 = VINDCDC3 = VCC = VINLDO = 3.6V, T_A = –40°C to 85°C, typical values are at T_A = 25°C (unless otherwise noted)

PARAMETER		TEST CONDITIONS	MIN	TYP	MAX	UNIT
VDCDC1 STEP-DOWN CONVERTER						
V _I	Input voltage range, VINDCDC1		2.5		6	V
I _O	Maximum output current	V _O = 3.3V	1600			mA
I _{SD}	Shutdown supply current in VINDCDC1	EN_DCDC1 = GND		0.1	1	μA
R _{DS(on)}	P-channel MOSFET on-resistance	VINDCDC1 = V _{GS} = 3.6V		125	261	mΩ
I _{LP}	P-channel leakage current	VINDCDC1 = 6V			2	μA
R _{DS(on)}	N-channel MOSFET on-resistance	VINDCDC1 = V _{GS} = 3.6V		130	260	mΩ
I _{LN}	N-channel leakage current	V _{DS} = 6V		7	10	μA
I _{LIMF}	Forward current limit (P- and N-channel)	2.5V < V _{INMAIN} < 6V	1.75	1.97	2.15	A
f _S	Oscillator frequency		1.95	2.25	2.55	MHz
VDCDC1	Fixed output voltage MODE=0 (PWM/PFM)	2.8V	VINDCDC1 = 3.3V to 6V; 0 mA ≤ I _O ≤ 1.0A			2%
		3.3V				2%
	Fixed output voltage MODE=1 (PWM)	2.8V	VINDCDC1 = 3.7V to 6V; 0 mA ≤ I _O ≤ 1.0A			1%
		3.3V				1%
	Adjustable output voltage with resistor divider at DEFDCDC1 MODE = 0 (PWM/PFM)	VINDCDC1 = VDCDC1 + 0.4V (min 2.5V) to 6V; 0mA ≤ I _O ≤ 1.6A			–2%	2%
Adjustable output voltage with resistor divider at DEFDCDC1; MODE = 1 (PWM)	VINDCDC1 = VDCDC1 + 0.4V (min 2.5V) to 6V; 0mA ≤ I _O ≤ 1.6A			–1%	1%	
	Line regulation	VINDCDC1 = VDCDC1 + 0.3V (min. 2.5 V) to 6V; I _O = 10mA		0		%/V
	Load regulation	I _O = 10mA to 1.6A		0.25		%/A
t _{SS}	Soft start ramp time	VDCDC1 ramping from 5% to 95% of target value		750		μs
R(L1)	Internal resistance from L1 to GND			1		MΩ

6.8 Electrical Characteristics VDCDC2

VINDCDC1 = VINDCDC2 = VINDCDC3 = VCC = VINLDO = 3.6V, T_A = –40°C to 85°C, typical values are at T_A = 25°C (unless otherwise noted)

PARAMETER		TEST CONDITIONS	MIN	TYP	MAX	UNIT
VDCDC2 STEP-DOWN CONVERTER						
V _I	Input voltage range, VINDCDC2		2.5		6	V
I _O	Maximum output current	V _O = 2.5V	800			mA
I _{SD}	Shutdown supply current in VINDCDC2	EN_DCDC2 = GND		0.1	1	μA
R _{DS(on)}	P-channel MOSFET on-resistance	VINDCDC2 = V _{GS} = 3.6V		140	300	mΩ
I _{LP}	P-channel leakage current	VINDCDC2 = 6.0V			2	μA
R _{DS(on)}	N-channel MOSFET on-resistance	VINDCDC2 = V _{GS} = 3.6V		150	297	mΩ
I _{LN}	N-channel leakage current	V _{DS} = 6V		7	10	μA

Electrical Characteristics VDCDC2 (continued)

VINDCDC1 = VINDCDC2 = VINDCDC3 = VCC = VINLDO = 3.6V, T_A = –40°C to 85°C, typical values are at T_A = 25°C (unless otherwise noted)

PARAMETER		TEST CONDITIONS		MIN	TYP	MAX	UNIT	
I _{LIMF}	Forward current limit (P- and N-channel)	2.5V < VINDCDC2 < 6V		1.05	1.16	1.29	A	
f _S	Oscillator frequency			1.95	2.25	2.55	MHz	
VDCDC2	Fixed output voltage MODE = 0 (PWM/PFM)	1.8V	VINDCDC2 = 2.5V to 6V; 0 mA ≤ I _O ≤ 1.6A	–2%		2%		
		2.5V	VINDCDC2 = 3V to 6V; 0 mA ≤ I _O ≤ 1.6A	–2%		2%		
	Fixed output voltage MODE = 1 (PWM)	1.8V	VINDCDC2 = 2.5V to 6V; 0 mA ≤ I _O ≤ 1.6A	–2%		2%		
		2.5V	VINDCDC2 = 3V to 6V; 0 mA ≤ I _O ≤ 1.6A	–1%		1%		
	Adjustable output voltage with resistor divider at DEFDCDC2 MODE = 0 (PWM)		VINDCDC2 = VDCDC2 + 0.5V (min 2.5V) to 6V; 0mA ≤ I _O ≤ 1.6A		–2%		2%	
	Adjustable output voltage with resistor divider at DEFDCDC2; MODE = 1 (PWM)		VINDCDC2 = VDCDC2 + 0.5V (min 2.5V) to 6V; 0mA ≤ I _O ≤ 1.6A		–1%		1%	
Line regulation		VINDCDC2 = VDCDC2 + 0.3 V (min. 2.5 V) to 6V; I _O = 10mA		0.0			%/V	
Load regulation		I _O = 10mA to 1.6A		0.25			%/A	
t _{SS}	Soft start ramp time	VDCDC2 ramping from 5% to 95% of target value		750			μs	
R(L2)	Internal resistance from L2 to GND			1			MΩ	

6.9 Electrical Characteristics VDCDC3

VINDCDC1 = VINDCDC2 = VINDCDC3 = VCC = VINLDO = 3.6V, T_A = –40°C to 85°C, typical values are at T_A = 25°C (unless otherwise noted)

PARAMETER		TEST CONDITIONS		MIN	TYP	MAX	UNIT
VDCDC3 STEP-DOWN CONVERTER							
V _I	Input voltage range, VINDCDC3			2.5		6.0	V
I _O	Maximum output current	V _O = 1.6V		800			mA
I _{SD}	Shutdown supply current in VINDCDC3	EN_DCDC3 = GND			0.1	1	μA
R _{DS(on)}	P-channel MOSFET on-resistance	VINDCDC3 = V _{GS} = 3.6V			310	698	mΩ
I _{LP}	P-channel leakage current	VINDCDC3 = 6V			0.1	2	μA
R _{DS(on)}	N-channel MOSFET on-resistance	VINDCDC3 = V _{GS} = 3.6V			220	503	mΩ
I _{LN}	N-channel leakage current	V _{DS} = 6.0V			7	10	μA
I _{LIMF}	Forward current limit (P- and N-channel)	2.5V < VINDCDC3 < 6V		1.00	1.20	1.40	A
f _S	Oscillator frequency			1.95	2.25	2.55	MHz
VDCDC3	Adjustable output voltage with resistor divider at DEFDCDC2 MODE = 0 (PWM)	VINDCDC3 = VDCDC3 + 0.5V (min 2.5V) to 6V; 0mA ≤ I _O ≤ 0.8A		–2%		2%	
	Adjustable output voltage with resistor divider at DEFDCDC2; MODE = 1 (PWM)	VINDCDC3 = VDCDC3 + 0.5V (min 2.5V) to 6V; 0mA ≤ I _O ≤ 0.8A		–1%		1%	
Line regulation		VINDCDC3 = VDCDC3 + 0.3V (min. 2.5 V) to 6V; I _O = 10mA		0.0			%/V
Load regulation		I _O = 10mA to 600mA		0.25			%/A
t _{SS}	Soft start ramp time	VDCDC3 ramping from 5% to 95% of target value		750			μs
R(L3)	Internal resistance from L3 to GND			1			MΩ

6.10 Typical Characteristics

Table 1. Table of Graphs

			FIGURE
η	Efficiency VDCDC1	vs Load current PWM/PFM; $V_O = 3.3V$	Figure 1
η	Efficiency VDCDC1	vs Load current PWM; $V_O = 3.3V$	Figure 2
η	Efficiency VDCDC2	vs Load current PWM/PFM; $V_O = 1.8V$	Figure 3
η	Efficiency VDCDC2	vs Load current PWM; $V_O = 1.8V$	Figure 4
η	Efficiency VDCDC3	vs Load current PWM/PFM; $V_O = 1.3V$	Figure 5
η	Efficiency VDCDC3	vs Load current PWM; $V_O = 1.3V$	Figure 6

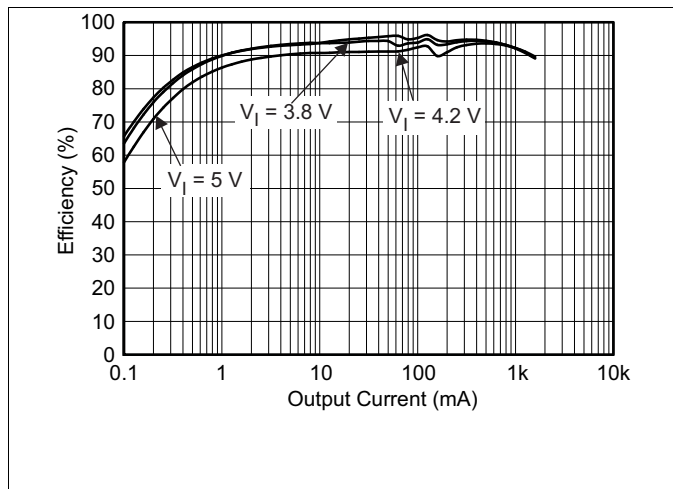

Figure 1. DCDC1: Efficiency vs Output Current

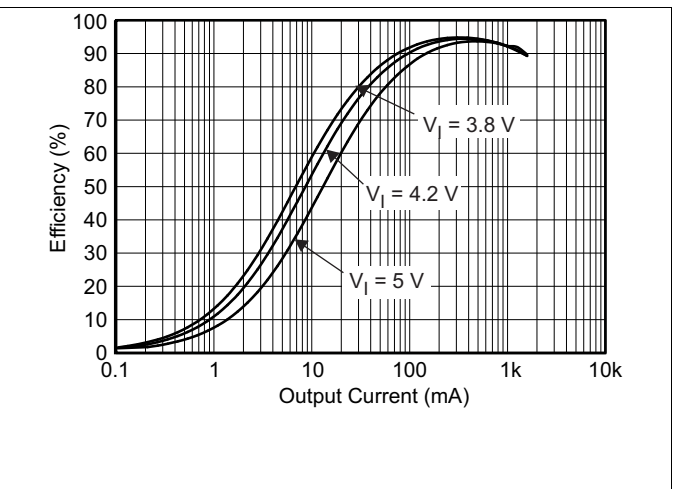

Figure 2. DCDC1: Efficiency vs Output Current

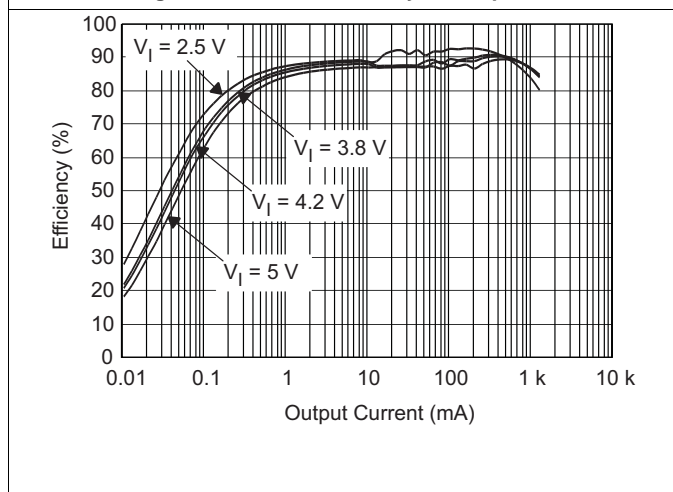

Figure 3. DCDC2: Efficiency vs Output Current

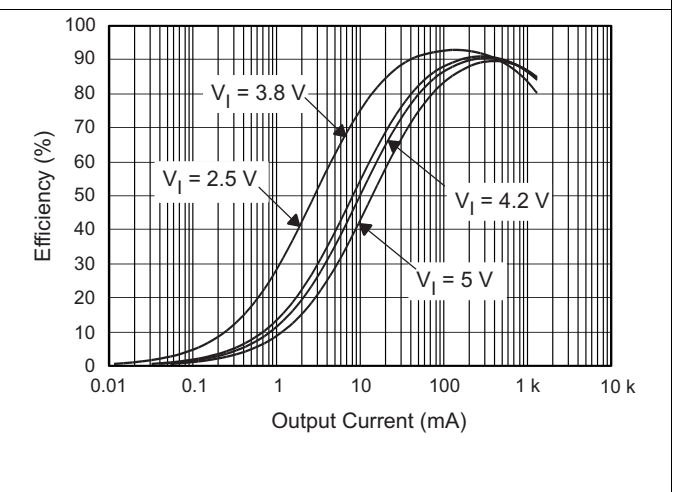

Figure 4. DCDC2: Efficiency vs Output Current

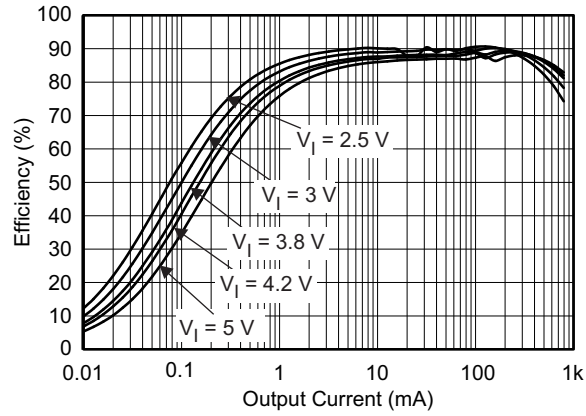

Figure 5. DCDC3: Efficiency vs Output Current

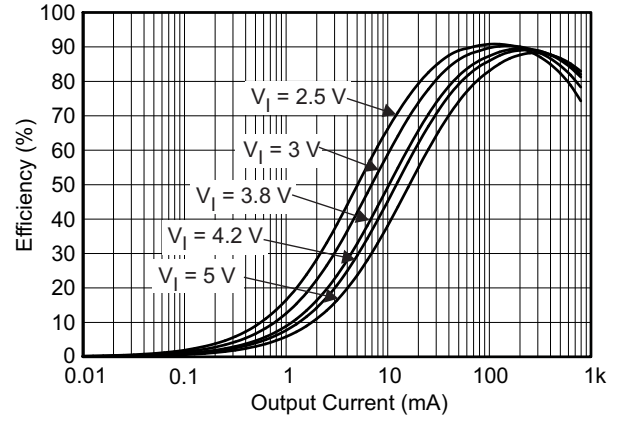

Figure 6. DCDC3: Efficiency vs Output Current

7 Detailed Description

7.1 Overview

The TPS650250 integrates three step-down converters, two general purpose LDOs and one always on low power LDO for applications powered by one LI-Ion or Li-Polymer cell or a single input voltage from 2.5 V to 6 V.

7.2 Functional Block Diagram

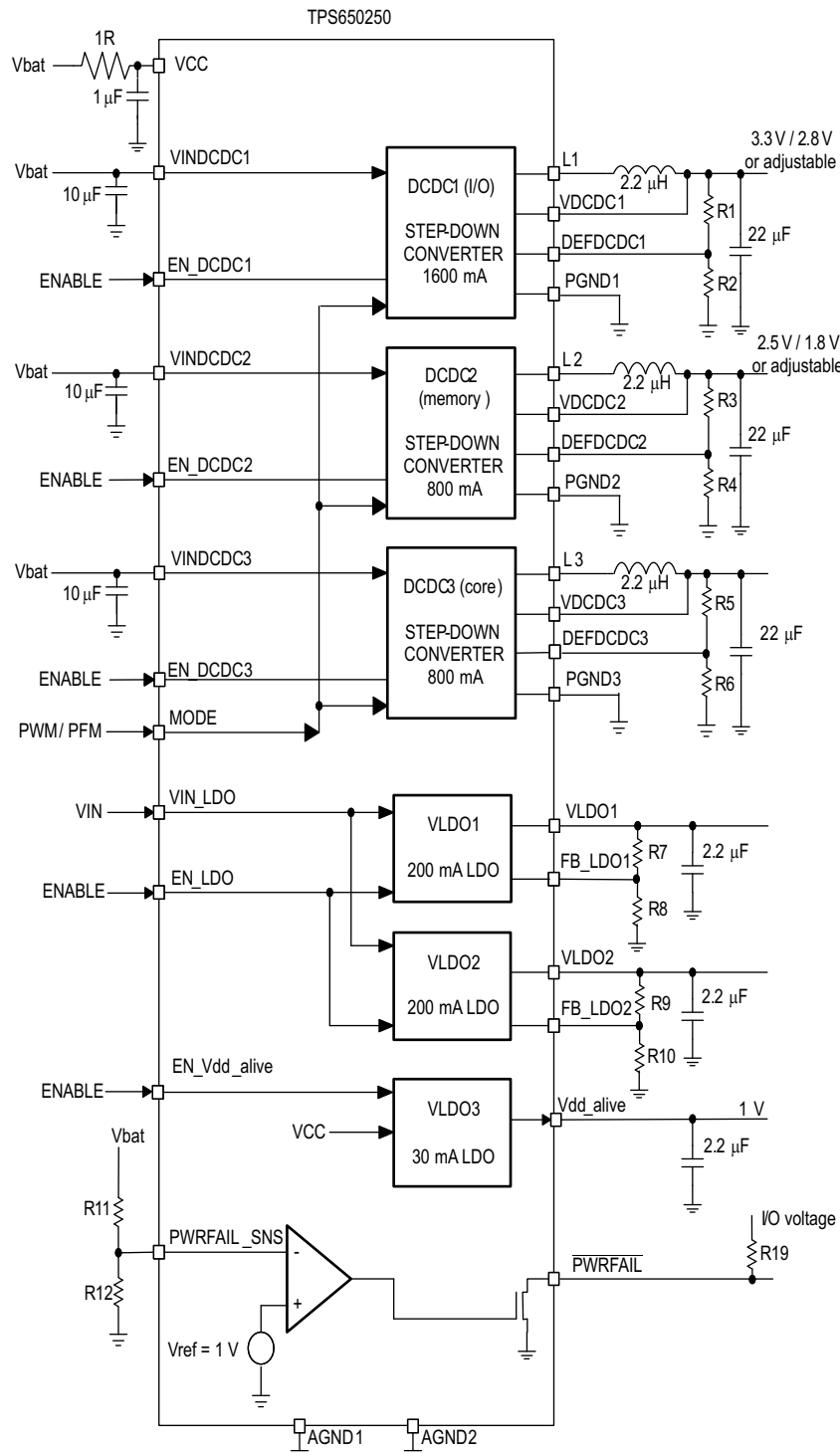

7.3 Feature Description

7.3.1 Step-Down Converters, VDCDC1, VDCDC2 AND VDCDC3

The TPS650250 incorporates three synchronous step-down converters operating typically at 2.25 MHz fixed frequency PWM (Pulse Width Modulation) at moderate to heavy load currents. At light load currents the converters automatically enter Power Save Mode and operate with PFM (Pulse Frequency Modulation). VDCDC1 delivers up to 1.6 A, VDCDC2 and VDCDC3 are capable of delivering up to 0.8 A of output current.

The converter output voltages can be programmed via the DEFDCDC1, DEFDCDC2 and DEFDCDC3 pins. The pins can either be connected to GND, VCC or to a resistor divider between the output voltage and GND. The VDCDC1 converter defaults to 2.8 V or 3.3 V depending on the DEFDCDC1 configuration pin, if DEFDCDC1 is tied to ground the default is 2.80 V, if it is tied to VCC the default is 3.3 V. When the DEFDCDC1 pin is connected to a resistor divider, the output voltage can be set in the range of 0.6 V to VINDCDC1 V. Reference the section on Output Voltage Selection for details on setting the output voltage range.

The VDCDC2 converter defaults to 1.8 V or 2.5 V depending on the DEFDCDC2 configuration pin, if DEFDCDC2 is tied to ground the default is 1.8 V, if it is tied to VCC the default is 2.5 V. When the DEFDCDC2 pin is connected to a resistor divider, the output voltage can be set in the range of 0.6 V to VINDCDC2 V.

On the DEFDCDC3 pin for the VDCDC3 converter, a resistor divider must be connected to set the output voltage. This pin does not accept a logic signal like DEFDCDC1 or DEFDCDC2. The value for the resistor divider can be changed during operation, so voltage scaling can be implemented by changing the resistor value.

During PWM operation the converters use a unique fast response voltage mode controller scheme with input voltage feed-forward to achieve good line and load regulation allowing the use of small ceramic input and output capacitors. At the beginning of each clock cycle initiated by the clock signal, the P-channel MOSFET switch is turned on and the inductor current ramps up until the comparator trips and the control logic turns off the switch. The current limit comparator also turns off the switch in case the current limit of the P-channel switch is exceeded. After the adaptive dead time used to prevent shoot through current, the N-channel MOSFET rectifier is turned on and the inductor current ramps down. The next cycle is initiated by the clock signal again turning off the N-channel rectifier and turning on the P-channel switch.

The three DC-DC converters operate synchronized to each other, with the VDCDC1 converter as the master. A 180° phase shift between the VDCDC1 switch turn on and the VDCDC2 and a further 90° shift to the VDCDC3 switch turn on decreases the input RMS current and smaller input capacitors can be used. This is optimized for a typical application where the VDCDC1 converter regulates a Li-Ion battery voltage of 3.7 V to 3.3 V, the VDCDC2 converter from 3.7 V to 2.5 V and the VDCDC3 converter from 3.7 V to 1.5 V.

7.3.2 Power Save Mode Operation

As the load current decreases, the converters enter Power Save Mode operation. During Power Save Mode the converters operate in a burst mode (PFM mode) with a frequency between 1.125 MHz and 2.25 MHz for one burst cycle. However, the frequency between different burst cycles depends on the actual load current and is typically far less than the switching frequency, with a minimum quiescent current to maintain high efficiency.

In order to optimize the converter efficiency at light load the average current is monitored and if in PWM mode the inductor current remains below a certain threshold, then Power Save Mode is entered. The typical threshold to enter Power Save Mode can be calculated as follows:

$$\begin{aligned}
 I_{\text{PFMDCDC1enter}} &= \frac{V_{\text{INDCDC1}}}{24 \Omega} \\
 I_{\text{PFMDCDC2enter}} &= \frac{V_{\text{INDCDC2}}}{26 \Omega} \\
 I_{\text{PFMDCDC3leave}} &= \frac{V_{\text{INDCDC3}}}{39 \Omega}
 \end{aligned} \tag{1}$$

During Power Save Mode the output voltage is monitored with a comparator and by maximum skip burst width. As the output voltage falls below the threshold, set to the nominal V_O , the P-channel switch turns on and the converter effectively delivers a constant current as defined below.

Feature Description (continued)

$$I_{\text{PFMDCDC1leave}} = \frac{V_{\text{INDCDC 1}}}{18 \Omega}$$

$$I_{\text{PFMDCDC2leave}} = \frac{V_{\text{INDCDC 2}}}{20 \Omega}$$

$$I_{\text{PFMDCDC3enter}} = \frac{V_{\text{INDCDC 3}}}{29 \Omega} \quad (2)$$

If the load is below the delivered current then the output voltage rises until the same threshold is crossed in the other direction. All switching activity ceases, reducing the quiescent current to a minimum until the output voltage has again dropped below the threshold. The power save mode is exited, and the converter returns to PWM mode if either of the following conditions are met:

1. The output voltage drops 2% below the nominal V_O due to increased load current
2. The PFM burst time exceeds $16 \times 1/f_s$ (7.1 μs typical)

These control methods reduce the quiescent current to typically 14 μA per converter and the switching activity to a minimum thus achieving the highest converter efficiency. Setting the comparator thresholds at the nominal output voltage at light load current results in a very low output voltage ripple. The ripple depends on the comparator delay and the size of the output capacitor; increasing capacitor values makes the output ripple tend to zero. Power Save Mode can be disabled by pulling the MODE pin high. This forces all DC-DC converters into fixed frequency PWM mode.

7.3.3 Soft Start

Each of the three converters has an internal soft start circuit that limits the inrush current during start-up. The soft start is realized by using a very low current to initially charge the internal compensation capacitor. The soft start time is typically 750 μs if the output voltage ramps from 5% to 95% of the final target value. If the output is already pre-charged to some voltage when the converter is enabled, then this time is reduced proportionally. There is a short delay of typically 170 μs between the converter being enabled and switching activity actually starting. This is to allow the converter to bias itself properly, to recognize if the output is pre-charged, and if so, to prevent discharging of the output while the internal soft start ramp catches up with the output voltage.

7.3.4 100% Duty Cycle Low Dropout Operation

The TPS650250x converters offer a low input to output voltage difference while still maintaining operation with the use of the 100% duty cycle mode. In this mode the P-channel switch is constantly turned on. This is particularly useful in battery-powered applications to achieve the longest operation time by taking full advantage of the whole battery voltage range. The minimum input voltage required to maintain DC regulation depends on the load current and output voltage and can be calculated as:

$$V_{\text{in}_{\text{min}}} = V_{\text{out}_{\text{min}}} + I_{\text{out}_{\text{max}}} \times (R_{\text{DSon}_{\text{max}}} + R_L)$$

where

- $I_{\text{out}_{\text{max}}}$ = Maximum load current (note: ripple current in the inductor is zero under these conditions)
 - $R_{\text{DSon}_{\text{max}}}$ = Maximum P-channel switch R_{DSon}
 - R_L = DC resistance of the inductor
 - $V_{\text{out}_{\text{min}}}$ = Nominal output voltage minus 2% tolerance limit
- (3)

7.3.5 Low Dropout Voltage Regulators

The low dropout voltage regulators are designed to operate well with low value ceramic input and output capacitors. They operate with input voltages down to 1.5 V. The LDOs offer a maximum dropout voltage of 300 mV at the rated output current. Each LDO sports a current limit feature. Both LDOs are enabled by the EN_LDO pin. The LDOs also have reverse conduction prevention. This allows the possibility to connect external regulators in parallel in systems with a backup battery. The TPS650250 step-down and LDO voltage regulators automatically power down when the V_{CC} voltage drops below the UVLO threshold or when the junction temperature rises above 160°C.

Feature Description (continued)

7.3.6 Undervoltage Lockout

The undervoltage lockout circuit for the five regulators on the TPS650250x prevents the device from malfunctioning at low input voltages and from excessive discharge of the battery. It disables the converters and LDOs. The UVLO circuit monitors the V_{cc} pin; the threshold is set internally to 2.35 V with 5% (120 mV) hysteresis. Note that when any of the DC-DC converters are running there is an input current at the V_{cc} pin, which can be up to 3 mA when all three converters are running in PWM mode. This current needs to be taken into consideration if an external RC filter is used at the V_{cc} pin to remove switching noise from the TPS650250x internal analog circuitry supply. See the V_{cc}-Filter section for details on the external RC filter.

7.3.7 PWRFAIL

The PWRFAIL signal is generated by a voltage detector at the PWRFAIL_SNS input. The input signal is compared to a 1 V threshold (falling edge) with 5% (50 mV) hysteresis. PWRFAIL is an open drain output which is actively low when the input voltage at PWRFAIL_SNS is below the threshold.

7.4 Device Functional Modes

The TPS650250x power-up sequencing is designed to be entirely flexible and customer driven; this is achieved simply by providing separate enable pins for each switch-mode converter and a common enable signal for LDO1 and LDO2. The relevant control pins are described in [Table 2](#).

Table 2. Control Pins for DCDC Converters

PIN NAME	INPUT/ OUTPUT	FUNCTION
DEFDCDC3	I	Defines the default voltage of the VDCDC3 switching converter set with an external resistor divider.
DEFDCDC2	I	Defines the default voltage of the VDCDC2 switching converter. DEFDCDC2 = 0 defaults VDCDC2 to 1.8V, DEFDCDC2 = VCC defaults VDCDC2 to 2.5V.
DEFDCDC1	I	Defines the default voltage of the VDCDC1 switching converter. DEFDCDC1 = 0 defaults VDCDC1 to 2.80V, DEFDCDC1 = VCC defaults VDCDC1 to 3.3V.
EN_DCDC3	I	Set EN_DCDC3 = 0 to disable or EN_DCDC3 = 1 to enable the VDCDC3 converter
EN_DCDC2	I	Set EN_DCDC2 = 0 to disable or EN_DCDC2 = 1 to enable the VDCDC2 converter
EN_DCDC1	I	Set EN_DCDC1 = 0 to disable or EN_DCDC1 = 1 to enable the VDCDC1 converter

8 Application and Implementation

NOTE

Information in the following applications sections is not part of the TI component specification, and TI does not warrant its accuracy or completeness. TI's customers are responsible for determining suitability of components for their purposes. Customers should validate and test their design implementation to confirm system functionality.

8.1 Application Information

This device integrates three step-down converters and three LDOs which can be used to power the voltage rails needed by a processor. A typical configuration for using the TPS650250 PMIC to power the Samsung processor S3C6400-533MHz is shown in [Figure 7](#).

8.2 Typical Application

8.2.1 Typical Configuration For The Samsung Processor S3C6400-533MHz

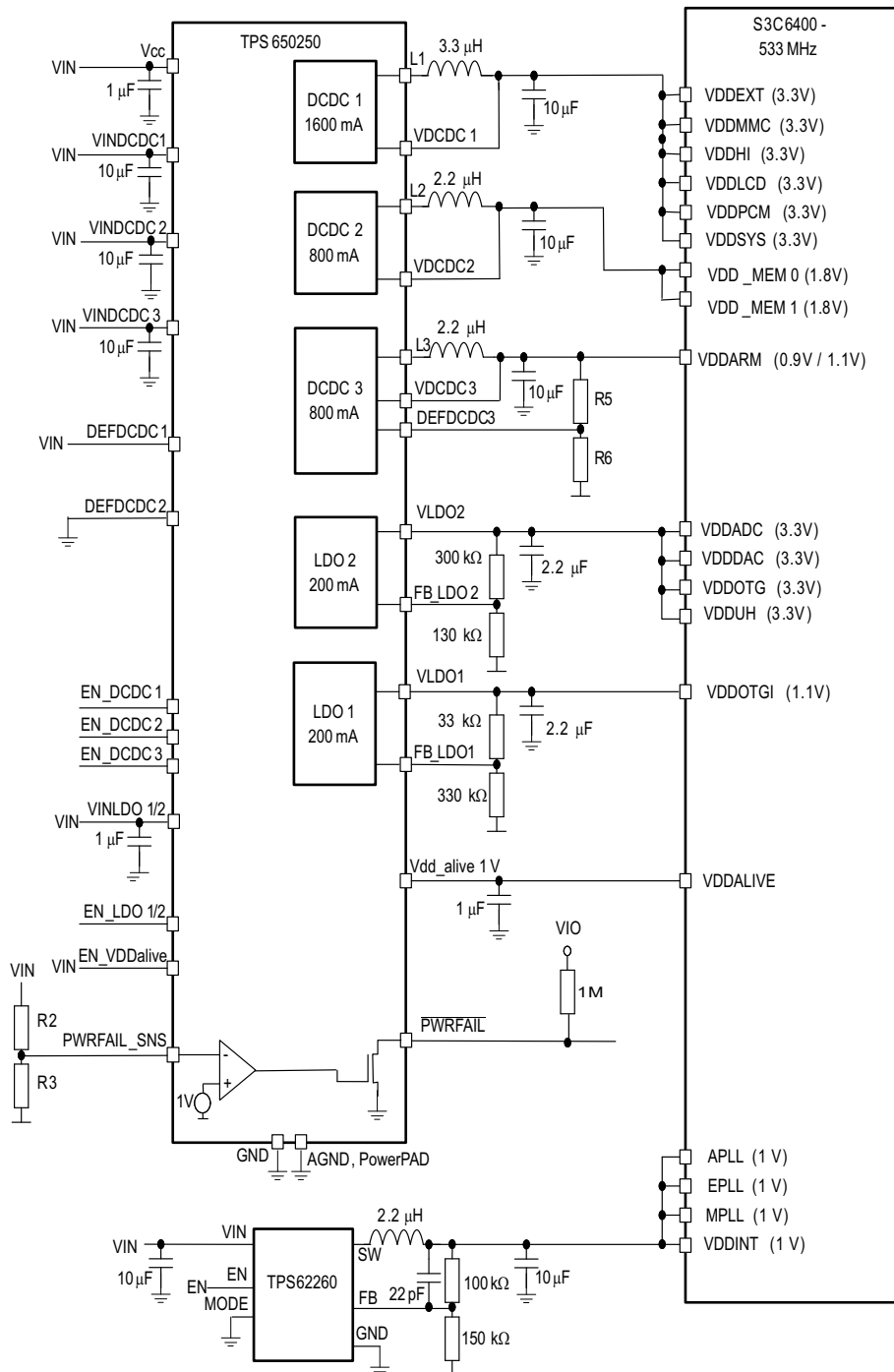

Figure 7. Samsung Processor Configuration

Typical Application (continued)

8.2.2 Design Requirements

The design parameters for the Samsung Processor Configuration are shown below.

Table 3. Design Parameters

Design Parameter	Value
Input Voltage Range	4.5 V to 5.5 V
DCDC1 Output Voltage	3.3 V
DCDC2 Output Voltage	1.8 V
DCDC3 Output Voltage	1.0 V
LDO1 Output Voltage	1.1 V
LDO2 Output Voltage	3.3 V

8.2.3 Detailed Design Procedure

This section describes the application design procedure for the TPS650250 PMIC.

8.2.3.1 Inductor Selection for the DCDC Converters

The three converters operate with 2.2 μH output inductors. Larger or smaller inductor values can be used to optimize performance of the device for specific conditions. The selected inductor has to be rated for its DC resistance and saturation current. The DC resistance of the inductor influences directly the efficiency of the converter. Therefore, an inductor with the lowest DC resistance should be selected for the highest efficiency.

For a fast transient response, a 2.2 μH inductor in combination with a 22 μF output capacitor is recommended. For an output voltage above 2.8 V, an inductor value of 3.3 μH minimum is required. Lower values result in an increased output voltage ripple in PFM mode. The minimum inductor value is 1.5 μH , but an output capacitor of 22 μF minimum is needed in this case.

[Equation 4](#) calculates the maximum inductor current under static load conditions. The saturation current of the inductor should be rated higher than the maximum inductor current as calculated with [Equation 4](#). This is recommended because during heavy load transient the inductor current rises above the calculated value.

$$\Delta I_L = V_{\text{out}} \times \frac{1 - \frac{V_{\text{out}}}{V_{\text{in}}}}{L \times f} \quad I_{L_{\text{max}}} = I_{\text{outmax}} + \frac{\Delta I_L}{2}$$

where

- f = Switching frequency (2.25 MHz typical)
- L = Inductor value
- ΔI_L = Peak-to-peak inductor ripple current
- $I_{L_{\text{max}}}$ = Maximum inductor current

(4)

The highest inductor current occurs at maximum V_{in} .

Open core inductors have a soft saturation characteristic and they can usually handle higher inductor currents versus a comparable shielded inductor.

A more conservative approach is to select the inductor current rating just for the maximum switch current of the corresponding converter. Consideration must be given to the difference in the core material from inductor to inductor which has an impact on efficiency especially at high switching frequencies. See [Table 4](#) and the typical applications for possible inductors.

Table 4. Tested Inductors

DEVICE	INDUCTOR VALUE	TYPE	COMPONENT SUPPLIER
DCDC3 Converter	3.3 μ H	LPS3015-332 (output current up to 1 A)	Coilcraft
	2.2 μ H	LPS3015-222 (output current up to 1 A)	Coilcraft
	3.3 μ H	VLCF4020T-3R3N1R5	TDK
	2.2 μ H	VLCF4020T-2R2N1R7	TDK
DCDC3 Converter	2.2 μ H	LPS3010-222	Coilcraft
	2.2 μ H	LPS3015-222	Coilcraft
	2.2 μ H	VLCF4020-2R2	TDK

8.2.3.2 Output Capacitor Selection

The advanced Fast Response voltage mode control scheme of the inductive converters implemented in the TPS650250x allows the use of small ceramic capacitors with a typical value of 10 μ F for each converter, without having large output voltage under and overshoots during heavy load transients. Ceramic capacitors having low ESR values have the lowest output voltage ripple and are recommended. Refer to [Table 5](#) for recommended components.

If ceramic output capacitors are used, the capacitor RMS ripple current rating will always meet the application requirements. For completeness, the RMS ripple current is calculated as:

$$I_{\text{RMS}C_{\text{out}}} = V_{\text{out}} \times \frac{1 - \frac{V_{\text{out}}}{V_{\text{in}}}}{L \times f} \times \frac{1}{2 \times \sqrt{3}} \quad (5)$$

At nominal load current the inductive converters operate in PWM mode and the overall output voltage ripple is the sum of the voltage spike caused by the output capacitor ESR plus the voltage ripple caused by charging and discharging the output capacitor:

$$\Delta V_{\text{out}} = V_{\text{out}} \times \frac{1 - \frac{V_{\text{out}}}{V_{\text{in}}}}{L \times f} \times \left(\frac{1}{8 \times C_{\text{out}} \times f} + \text{ESR} \right) \quad (6)$$

Where the highest output voltage ripple occurs at the highest input voltage, V_{in} .

At light load currents the converters operate in Power Save Mode and output voltage ripple is dependent on the output capacitor value. The output voltage ripple is set by the internal comparator delay and the external capacitor. Typical output voltage ripple is less than 1% of the nominal output voltage.

8.2.3.3 Input Capacitor Selection

Because of the nature of the buck converter having a pulsating input current, a low ESR input capacitor is required for best input voltage filtering and minimizing interference with other circuits caused by high input voltage spikes. Each DC-DC converter requires a 10 μ F ceramic input capacitor on its input pin VINDCDCx. The input capacitor can be increased without any limit for better input voltage filtering. The V_{cc} pin should be separated from the input for the DC-DC converters. A filter resistor of up to 10 Ω and a 1 μ F capacitor should be used for decoupling the V_{cc} pin from switching noise. Note that the filter resistor may affect the UVLO threshold since up to 3 mA can flow via this resistor into the V_{cc} pin when all converters are running in PWM mode.

Table 5. Possible Capacitors

CAPACITOR VALUE	CASE SIZE	COMPONENT SUPPLIER		COMMENTS
22 μ F	1206	TDK	C3216X5R0J226M	Ceramic
22 μ F	1206	Taiyo Yuden	JMK316BJ226ML	Ceramic
22 μ F	0805	TDK	C2012X5R0J226MT	Ceramic
22 μ F	0805	Taiyo Yuden	JMK212BJ226MG	Ceramic
10 μ F	0805	Taiyo Yuden	JMK212BJ106M	Ceramic
10 μ F	0805	TDK	C2012X5R0J106M	Ceramic

8.2.3.4 Output Voltage Selection

The DEFDCDC1, DEFDCDC2, and DEFDCDC3 pins are used to set the output voltage for each step-down converter. See Table 6 for the default voltages if the pins are pulled to GND or to V_{CC}.

Table 6. Voltage Options

PIN	LEVEL	DEFAULT OUTPUT VOLTAGE
DEFDCDC1	VCC	3.3 V
	GND	2.80 V
DEFDCDC2	VCC	2.5 V
	GND	1.8 V
DEFDCDC3	external voltage divider	0.6 V to V _{inDCDC3}

If a different voltage is needed, an external resistor divider can be added to the DEFDCDC1 or DEFDCDC2 pin as shown in Figure 8:

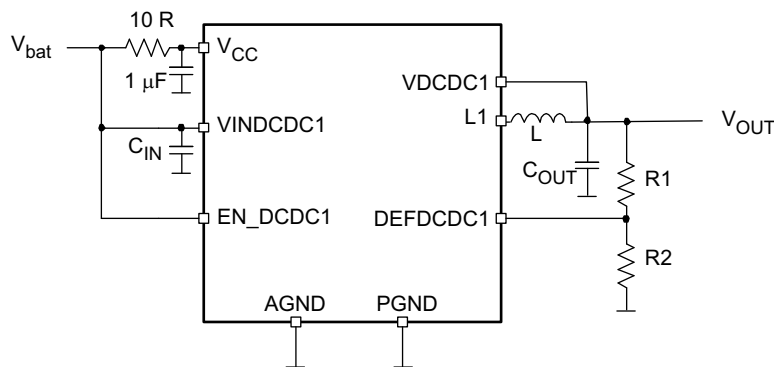

Figure 8. External Resistor Divider Added

When a resistor divider is connected to DEFDCDC1 or DEFDCDC2, the output voltage can be set from 0.6 V up to the input voltage V_{bat}. The total resistance (R1+R2) of the voltage divider should be kept in the 1 MΩ range in order to maintain a high efficiency at light load. V_{DEFDCDCx} = 0.6V

$$V_{OUT} = V_{DEFDCDCx} \times \frac{R1+R2}{R2}$$

$$R1 = R2 \times \left(\frac{V_{OUT}}{V_{DEFDCDCx}} \right) - R2$$

8.2.3.5 Voltage Change on VDCDC3

The output voltage of VDCDC3 is set with an external resistor divider at DEFDCDC3. This pin must not be connected to GND or VINDCDC3. The value of the resistor divider can be changed during operation to allow dynamic voltage scaling.

8.2.3.6 Vdd_alive Output

The Vdd_alive LDO is typically connected to the Vdd_alive input of the Samsung application processor. It provides an output voltage of 1 V at 30 mA. It is recommended to add a capacitor of 2.2 µF minimum to the Vdd_alive pin. The LDO can be disabled by pulling the EN_Vdd_alive pin to GND.

8.2.3.7 LDO1 and LDO2

The LDOs in the TPS650250 are general purpose LDOs which are stable using ceramics capacitors. The minimum output capacitor required is 2.2 µF. The LDOs output voltage can be changed to different voltages between 1 V and 3.3 V using an external resistor divider. Therefore they can also be used as general purpose LDOs in the application. The supply voltage for the LDOs needs to be connected to the VINLDO pin, giving the flexibility to connect the lowest voltage available in the system and therefore providing the highest efficiency.

The total resistance (R5+R6) of the voltage divider should be kept in the 1 MΩ range in order to maintain high efficiency at light load. $V_{FBLDOx} = 1.0$ V.

$$V_{OUT} = V_{FBLDOx} \times \frac{R5 + R6}{R6}$$

$$R5 = R6 \times \left(\frac{V_{OUT}}{V_{FBLDOx}} \right) - R6$$

8.2.3.8 Vcc-Filter

An RC filter connected at the Vcc input is used to keep noise from the internal supply for the bandgap and other analog circuitry. A typical value of 1 Ω and 1 μF is used to filter the switching spikes, generated by the DC-DC converters. A larger resistor than 10 Ω should not be used because the current into Vcc of up to 2.5 mA causes a voltage drop at the resistor causing the undervoltage lockout circuitry connected at Vcc internally to switch off too early.

8.2.4 Application Curves

The application curves were taken using the following inductor/output capacitor combinations

CONVERTER	INDUCTOR	OUTPUT CAPACITOR	OUTPUT CAPACITOR VALUE
DCDC1	VLCF4020-3R3	C2012X5R0J226M	22 μF
DCDC2	VLCF4020-2R2	C2012X5R0J226M	22 μF
DCDC3	LPS3010-222	C2012X5R0J226M	22 μF

Table 7. Table of Application Curves

		FIGURE
	Line transient response VDCDC1	Figure 9
	Line transient response VDCDC2	Figure 10
	Line transient response VDCDC3	Figure 11
	Load transient response VDCDC1	Figure 12
	Load transient response VDCDC2	Figure 13
	Load transient response VDCDC3	Figure 14
	Output voltage ripple DCDC2; PFM mode	Figure 15
	Output voltage ripple DCDC2; PWM mode	Figure 16
	Load regulation for Vdd_alive	Figure 17
	Start-up VDCDC1 to VDCDC3	Figure 18
	Start-up LDO1 and LDO2	Figure 19

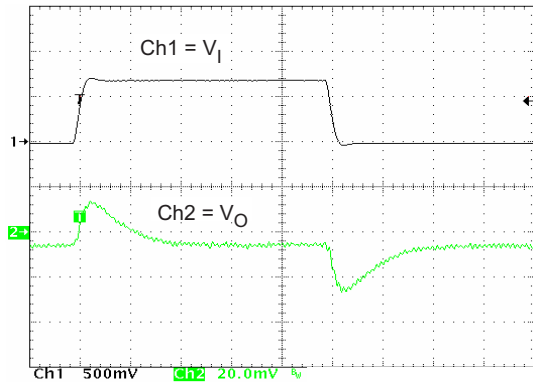

Figure 9. VDCDC1 Line Transient Response

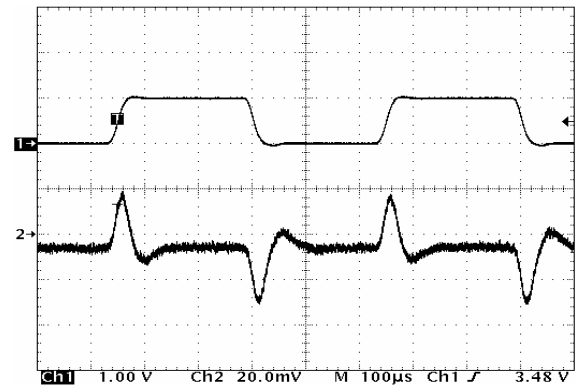

Figure 10. VDCDC2 Line Transient Response

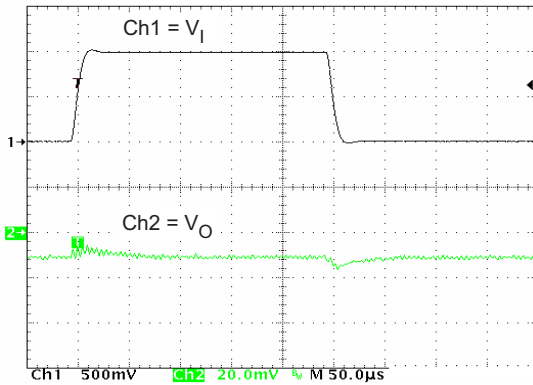

Figure 11. VDCDC3 Line Transient Response

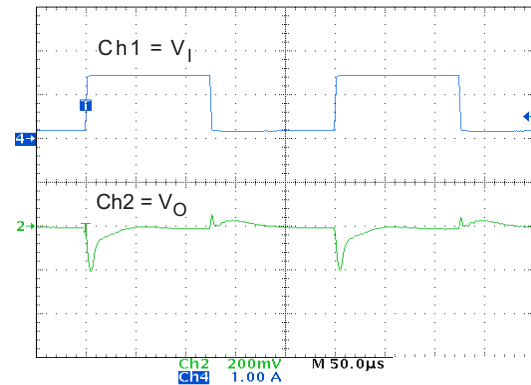

Figure 12. VDCDC1 Load Transient Response

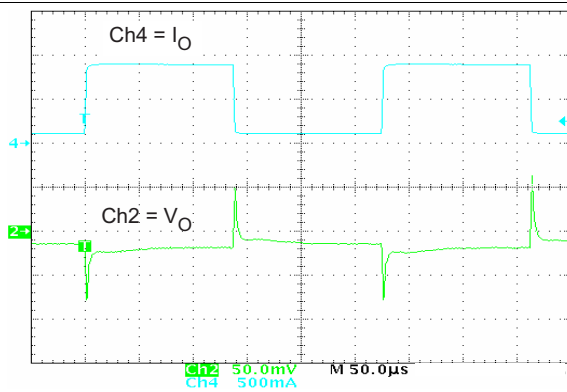

Figure 13. VDCDC2 Load Transient Response

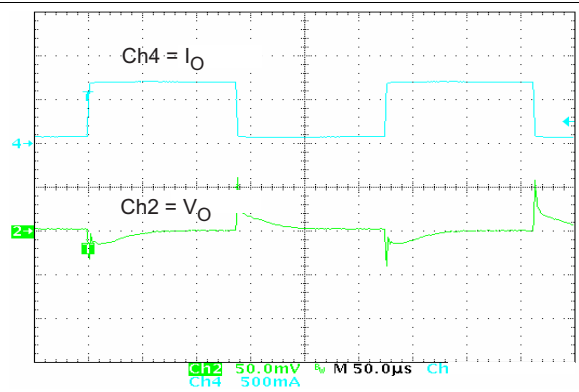

Figure 14. VDCDC3 Load Transient Response

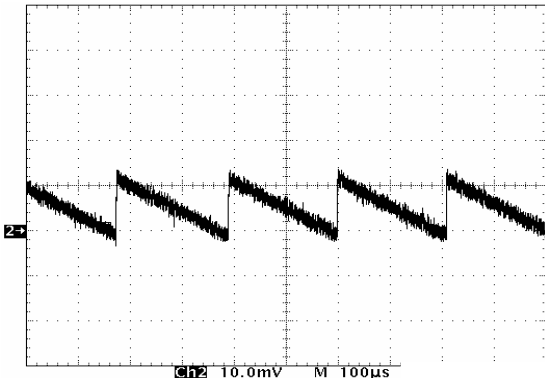

Figure 15. VDCDC2 Output Voltage Ripple

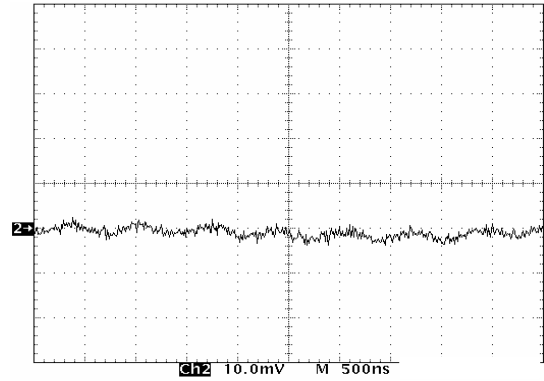

Figure 16. VDCDC2 Output Voltage Ripple

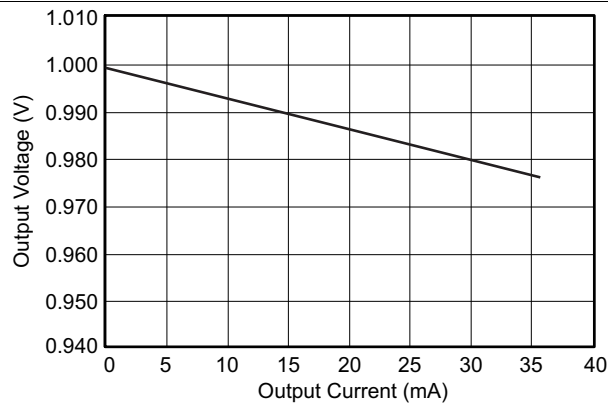

Figure 17. VDD_ALIVE Output Voltage vs Output Current

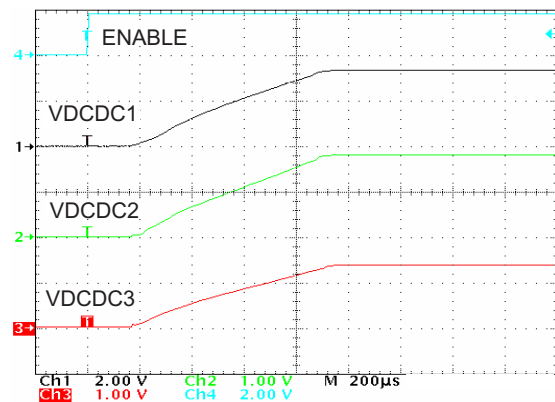

Figure 18. Startup VDCDC1, VDCDC2, VDCDC3

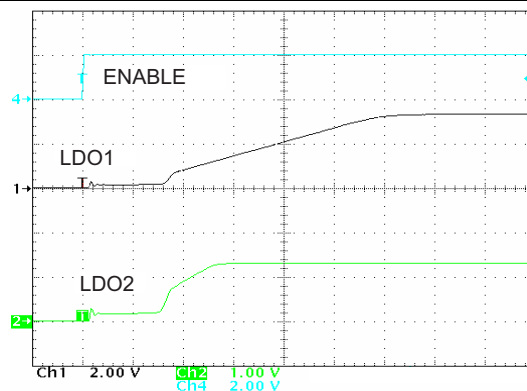

Figure 19. Startup LDO1 and LDO2

9 Power Supply Recommendations

The TPS650250 is designed to operate from an input voltage supply range between 3.5 V and 5.5 V. The input supply should be well regulated. If the input supply is located more than a few inches from the TPS650250, additional bulk capacitance may be required in addition to the ceramic bypass capacitors.

10 Layout

10.1 Layout Guidelines

- The VINDCDC1, VINDCDC2 and VINDCDC3 terminals should be bypassed to ground with a low ESR ceramic bypass capacitor. The typical recommended bypass capacitance is 10 uF ceramic with a X5R or X7R dielectric.
- The VINLDO terminal should be bypassed to ground with a low ESR ceramic bypass capacitor. The typical recommended bypass capacitance is 1 uF ceramic with a X5R or X7R dielectric.
- The optimum placement is closest to the individual voltage terminals and the AGNDx terminals.
- The AGNDx terminals should be tied to the pcb ground plane at the terminal of the IC.
- The cross sectional area loop from the input capacitor to the VINDCDCx input and corresponding PGNDx terminal should be minimized as much as possible.
- Route the feedback signal for each of the step-down converters next to the current path of the converter in order to decrease the cross sectional area of the feedback loop which minimizes noise injection into the loop.
- Do not route any noise sensitive signals under or next to any of the step-down inductors. Ensure a keepout region directly under the inductors or at least provide ground shielding.
- It is recommended to have the layer directly underneath the IC to be a solid copper ground plane.

10.2 Layout Example

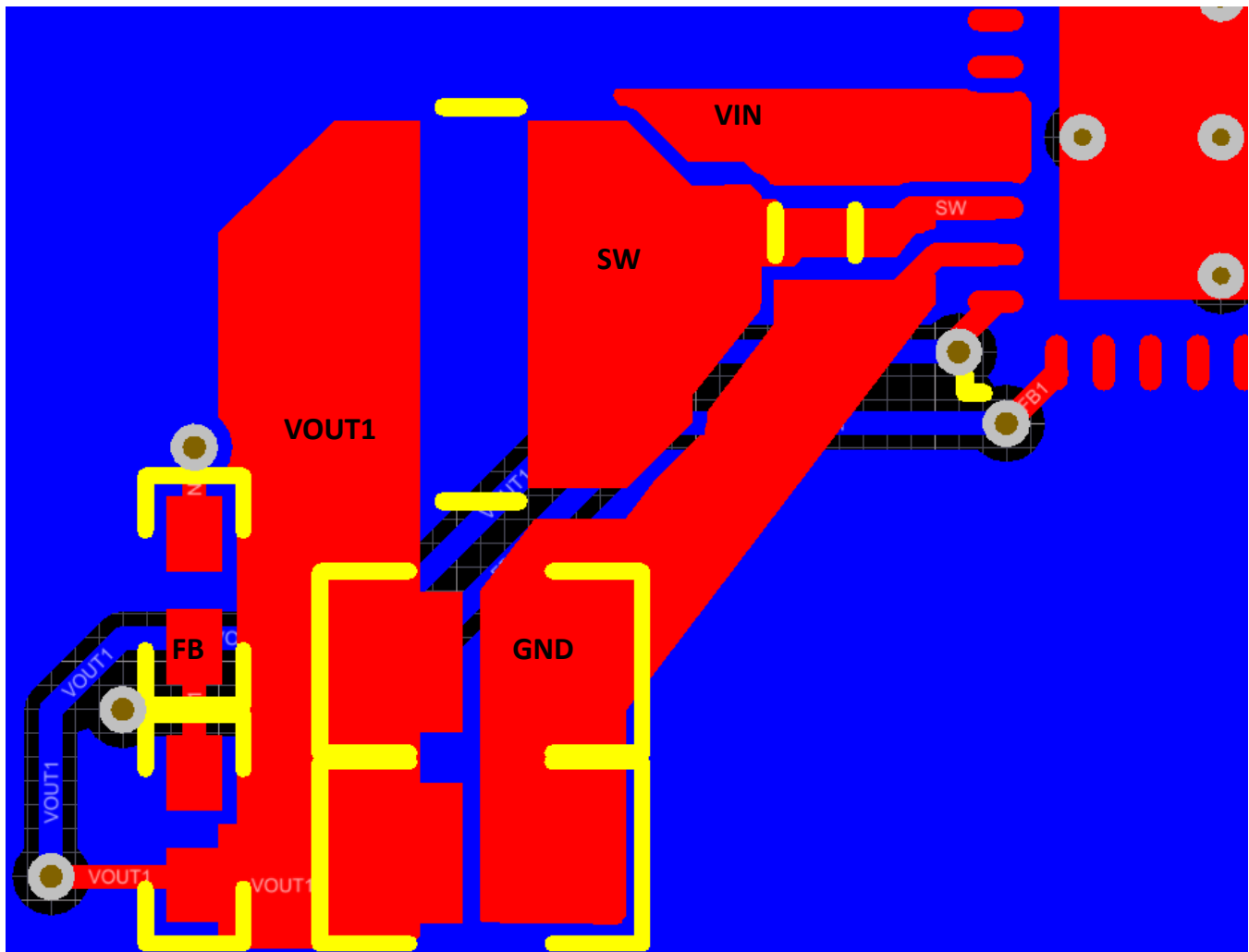

Figure 20. Layout Example of VDCDC1

The most important layout practice is the placement of the input capacitor. The input capacitor should be placed as close as possible to the VINDCDCx and GND pins of the converters in order to minimize the parasitic inductance and loop.

The second most important layout practice is to minimize the feedback cross-sectional loop of the converters. Route the feedback trace along a close path of the VOUT and switch nodes.

11 Device and Documentation Support

11.1 Device Support

11.1.1 Third-Party Products Disclaimer

TI'S PUBLICATION OF INFORMATION REGARDING THIRD-PARTY PRODUCTS OR SERVICES DOES NOT CONSTITUTE AN ENDORSEMENT REGARDING THE SUITABILITY OF SUCH PRODUCTS OR SERVICES OR A WARRANTY, REPRESENTATION OR ENDORSEMENT OF SUCH PRODUCTS OR SERVICES, EITHER ALONE OR IN COMBINATION WITH ANY TI PRODUCT OR SERVICE.

11.1.2 Development Support

For development support, refer to:

- [DDR-less EtherCAT® Slave on AMIC110 Reference Design](#)
- [EtherCAT Slave and Multi-Protocol Industrial Ethernet Reference Design](#)
- [Xilinx Spartan 6 FPGA Power Reference Design with TPS650250](#)
- [Universal Line Power Supply for PLC using PSR Flyback and Compact DC/DC Stages Reference Design](#)
- [Smart Home and Energy Gateway Reference Design](#)
- [Streaming Audio Reference Design](#)

11.2 Documentation Support

11.2.1 Related Documentation

For related documentation see the following:

- Texas Instruments, [Empowering Designs With Power Management IC \(PMIC\) for Processor Applications application report](#)
- Texas Instruments, [Optimizing Resistor Dividers at a Comparator Input application report](#)
- Texas Instruments, [Power Supply Reference Design for Samsung™ s3c2416 Using TPS650240 or TPS650250](#)
- Texas Instruments, [Powering the AM335x With the TPS650250 user's guide](#)
- Texas Instruments, [Using the TPS650250EVM Power Management IC for Li-Ion Powered Systems](#)

11.3 Receiving Notification of Documentation Updates

To receive notification of documentation updates, navigate to the device product folder on ti.com. In the upper right corner, click on *Alert me* to register and receive a weekly digest of any product information that has changed. For change details, review the revision history included in any revised document.

11.4 Community Resources

The following links connect to TI community resources. Linked contents are provided "AS IS" by the respective contributors. They do not constitute TI specifications and do not necessarily reflect TI's views; see TI's [Terms of Use](#).

TI E2E™ Online Community *TI's Engineer-to-Engineer (E2E) Community*. Created to foster collaboration among engineers. At e2e.ti.com, you can ask questions, share knowledge, explore ideas and help solve problems with fellow engineers.

Design Support *TI's Design Support* Quickly find helpful E2E forums along with design support tools and contact information for technical support.

11.5 Trademarks

E2E is a trademark of Texas Instruments.

EtherCAT is a registered trademark of Beckhoff Automation GmbH.

Samsung is a trademark of Samsung Semiconductor.

All other trademarks are the property of their respective owners.

11.6 Electrostatic Discharge Caution



This integrated circuit can be damaged by ESD. Texas Instruments recommends that all integrated circuits be handled with appropriate precautions. Failure to observe proper handling and installation procedures can cause damage.

ESD damage can range from subtle performance degradation to complete device failure. Precision integrated circuits may be more susceptible to damage because very small parametric changes could cause the device not to meet its published specifications.

11.7 Glossary



[SLYZ022](#) — *TI Glossary*.

This glossary lists and explains terms, acronyms, and definitions.

12 Mechanical, Packaging, and Orderable Information

The following pages include mechanical, packaging, and orderable information. This information is the most current data available for the designated devices. This data is subject to change without notice and revision of this document. For browser-based versions of this data sheet, refer to the left-hand navigation.

PACKAGING INFORMATION

Orderable Device	Status (1)	Package Type	Package Drawing	Pins	Package Qty	Eco Plan (2)	Lead/Ball Finish (6)	MSL Peak Temp (3)	Op Temp (°C)	Device Marking (4/5)	Samples
TPS650250RHBR	ACTIVE	VQFN	RHB	32	3000	Green (RoHS & no Sb/Br)	CU NIPDAU	Level-2-260C-1 YEAR	-40 to 85	TPS 650250	
TPS650250RHBT	ACTIVE	VQFN	RHB	32	250	Green (RoHS & no Sb/Br)	CU NIPDAU	Level-2-260C-1 YEAR	-40 to 85	TPS 650250	

(1) The marketing status values are defined as follows:

ACTIVE: Product device recommended for new designs.

LIFEBUY: TI has announced that the device will be discontinued, and a lifetime-buy period is in effect.

NRND: Not recommended for new designs. Device is in production to support existing customers, but TI does not recommend using this part in a new design.

PREVIEW: Device has been announced but is not in production. Samples may or may not be available.

OBSOLETE: TI has discontinued the production of the device.

(2) **RoHS:** TI defines "RoHS" to mean semiconductor products that are compliant with the current EU RoHS requirements for all 10 RoHS substances, including the requirement that RoHS substance do not exceed 0.1% by weight in homogeneous materials. Where designed to be soldered at high temperatures, "RoHS" products are suitable for use in specified lead-free processes. TI may reference these types of products as "Pb-Free".

RoHS Exempt: TI defines "RoHS Exempt" to mean products that contain lead but are compliant with EU RoHS pursuant to a specific EU RoHS exemption.

Green: TI defines "Green" to mean the content of Chlorine (Cl) and Bromine (Br) based flame retardants meet JS709B low halogen requirements of <=1000ppm threshold. Antimony trioxide based flame retardants must also meet the <=1000ppm threshold requirement.

(3) MSL, Peak Temp. - The Moisture Sensitivity Level rating according to the JEDEC industry standard classifications, and peak solder temperature.

(4) There may be additional marking, which relates to the logo, the lot trace code information, or the environmental category on the device.

(5) Multiple Device Markings will be inside parentheses. Only one Device Marking contained in parentheses and separated by a "~" will appear on a device. If a line is indented then it is a continuation of the previous line and the two combined represent the entire Device Marking for that device.

(6) Lead/Ball Finish - Orderable Devices may have multiple material finish options. Finish options are separated by a vertical ruled line. Lead/Ball Finish values may wrap to two lines if the finish value exceeds the maximum column width.

Important Information and Disclaimer:The information provided on this page represents TI's knowledge and belief as of the date that it is provided. TI bases its knowledge and belief on information provided by third parties, and makes no representation or warranty as to the accuracy of such information. Efforts are underway to better integrate information from third parties. TI has taken and continues to take reasonable steps to provide representative and accurate information but may not have conducted destructive testing or chemical analysis on incoming materials and chemicals. TI and TI suppliers consider certain information to be proprietary, and thus CAS numbers and other limited information may not be available for release.

In no event shall TI's liability arising out of such information exceed the total purchase price of the TI part(s) at issue in this document sold by TI to Customer on an annual basis.

OTHER QUALIFIED VERSIONS OF TPS650250 :

- Automotive: [TPS650250-Q1](#)

NOTE: Qualified Version Definitions:

- Automotive - Q100 devices qualified for high-reliability automotive applications targeting zero defects

TAPE AND REEL INFORMATION



QUADRANT ASSIGNMENTS FOR PIN 1 ORIENTATION IN TAPE



*All dimensions are nominal

Device	Package Type	Package Drawing	Pins	SPQ	Reel Diameter (mm)	Reel Width W1 (mm)	A0 (mm)	B0 (mm)	K0 (mm)	P1 (mm)	W (mm)	Pin1 Quadrant
TPS650250RHBR	VQFN	RHB	32	3000	330.0	12.4	5.3	5.3	1.5	8.0	12.0	Q2
TPS650250RHBT	VQFN	RHB	32	250	180.0	12.4	5.3	5.3	1.5	8.0	12.0	Q2

TAPE AND REEL BOX DIMENSIONS

*All dimensions are nominal

Device	Package Type	Package Drawing	Pins	SPQ	Length (mm)	Width (mm)	Height (mm)
TPS650250RHBR	VQFN	RHB	32	3000	367.0	367.0	35.0
TPS650250RHBT	VQFN	RHB	32	250	210.0	185.0	35.0

GENERIC PACKAGE VIEW

RHB 32

VQFN - 1 mm max height

5 x 5, 0.5 mm pitch

PLASTIC QUAD FLATPACK - NO LEAD

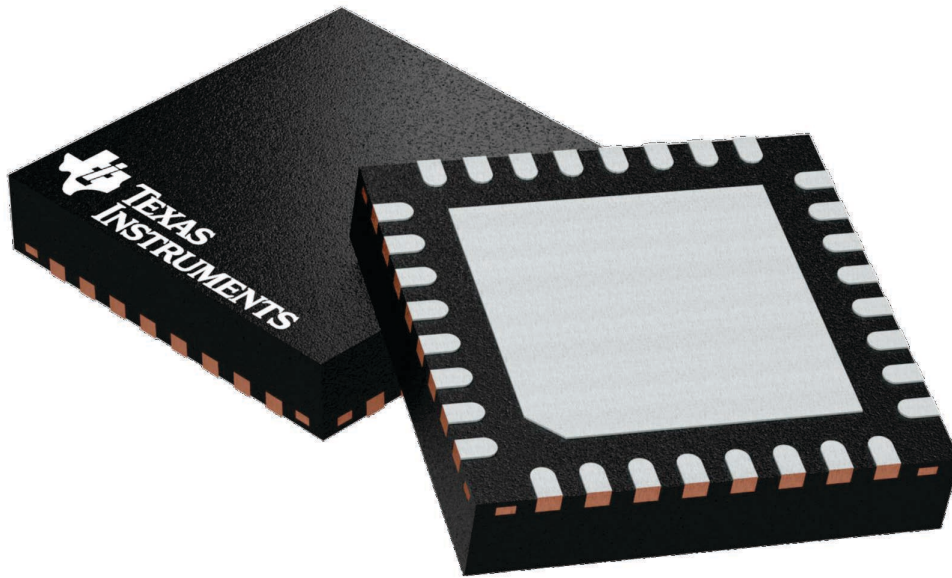

Images above are just a representation of the package family, actual package may vary.
Refer to the product data sheet for package details.

4224745/A

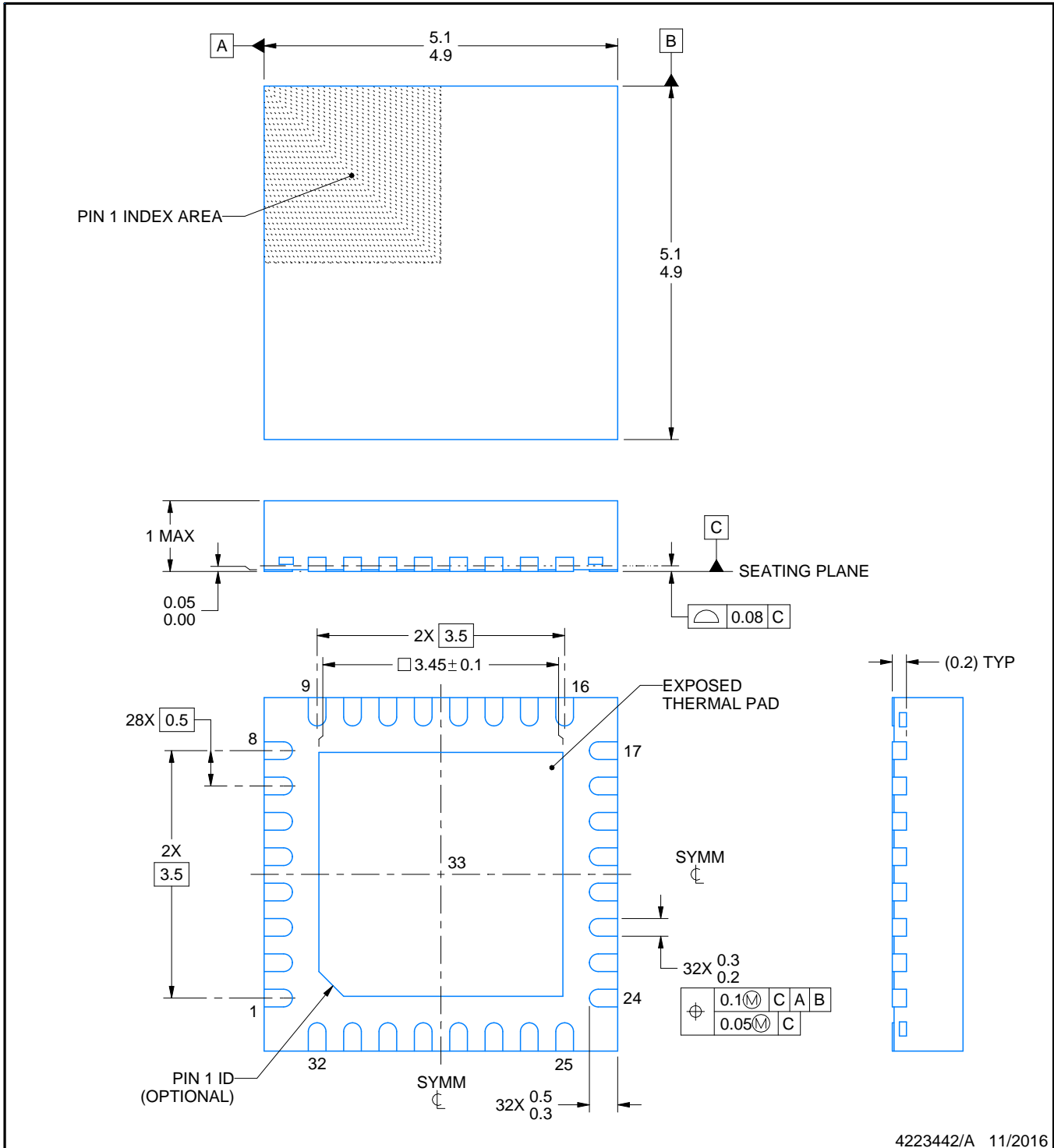
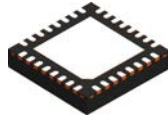

4223442/A 11/2016

NOTES:

1. All linear dimensions are in millimeters. Any dimensions in parenthesis are for reference only. Dimensioning and tolerancing per ASME Y14.5M.
2. This drawing is subject to change without notice.
3. The package thermal pad must be soldered to the printed circuit board for thermal and mechanical performance.

EXAMPLE STENCIL DESIGN

RHB0032E

VQFN - 1 mm max height

PLASTIC QUAD FLATPACK - NO LEAD

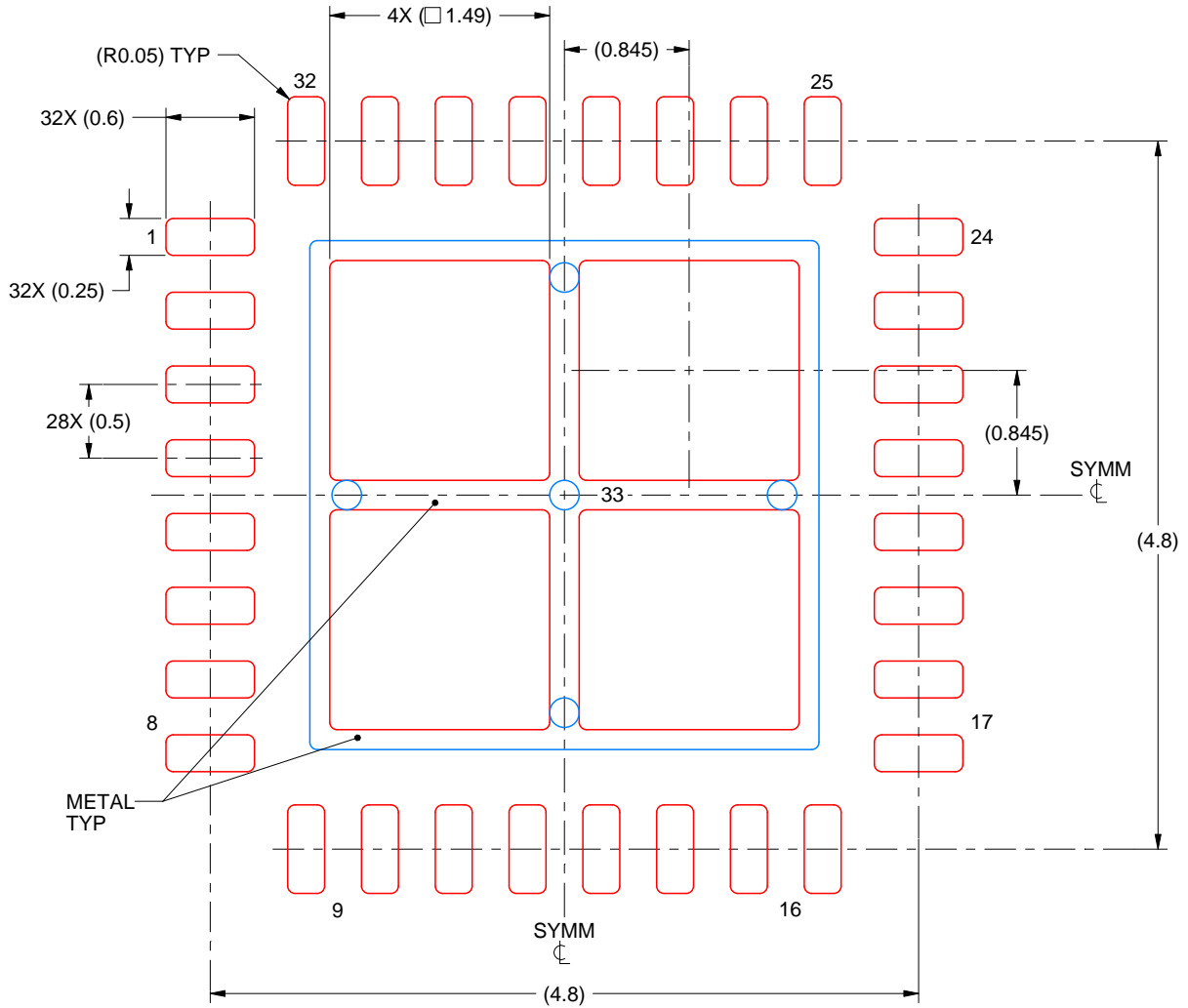

SOLDER PASTE EXAMPLE
 BASED ON 0.125 mm THICK STENCIL

EXPOSED PAD 33:
 75% PRINTED SOLDER COVERAGE BY AREA UNDER PACKAGE
 SCALE:20X

4223442/A 11/2016

NOTES: (continued)

6. Laser cutting apertures with trapezoidal walls and rounded corners may offer better paste release. IPC-7525 may have alternate design recommendations.

IMPORTANT NOTICE AND DISCLAIMER

TI PROVIDES TECHNICAL AND RELIABILITY DATA (INCLUDING DATASHEETS), DESIGN RESOURCES (INCLUDING REFERENCE DESIGNS), APPLICATION OR OTHER DESIGN ADVICE, WEB TOOLS, SAFETY INFORMATION, AND OTHER RESOURCES "AS IS" AND WITH ALL FAULTS, AND DISCLAIMS ALL WARRANTIES, EXPRESS AND IMPLIED, INCLUDING WITHOUT LIMITATION ANY IMPLIED WARRANTIES OF MERCHANTABILITY, FITNESS FOR A PARTICULAR PURPOSE OR NON-INFRINGEMENT OF THIRD PARTY INTELLECTUAL PROPERTY RIGHTS.

These resources are intended for skilled developers designing with TI products. You are solely responsible for (1) selecting the appropriate TI products for your application, (2) designing, validating and testing your application, and (3) ensuring your application meets applicable standards, and any other safety, security, or other requirements. These resources are subject to change without notice. TI grants you permission to use these resources only for development of an application that uses the TI products described in the resource. Other reproduction and display of these resources is prohibited. No license is granted to any other TI intellectual property right or to any third party intellectual property right. TI disclaims responsibility for, and you will fully indemnify TI and its representatives against, any claims, damages, costs, losses, and liabilities arising out of your use of these resources.

TI's products are provided subject to TI's Terms of Sale (www.ti.com/legal/termsofsale.html) or other applicable terms available either on ti.com or provided in conjunction with such TI products. TI's provision of these resources does not expand or otherwise alter TI's applicable warranties or warranty disclaimers for TI products.

Mailing Address: Texas Instruments, Post Office Box 655303, Dallas, Texas 75265
Copyright © 2019, Texas Instruments Incorporated

Looking for pricing, stock, or lifecycle information?

Click below to explore more details on WIN SOURCE:

 [View TPS650250RHBR](#) on WIN SOURCE

 [Texas Instruments](#) Information

Optimize Your Supply Chain with WIN SOURCE Solutions

-  Global Sourcing Solution
-  Obsolete Management
-  Cost Control Management
-  Shortage Management
-  Alternative Solution
-  Excess Inventory Management