



**THE DATASHEET OF  
TPS61181ARTER**





## Table of Contents

<b>1 Features</b> .....	<b>1</b>	8.4 Device Functional Modes.....	<b>11</b>
<b>2 Applications</b> .....	<b>1</b>	<b>9 Application and Implementation</b> .....	<b>12</b>
<b>3 Description</b> .....	<b>1</b>	9.1 Application Information.....	<b>12</b>
<b>4 Revision History</b> .....	<b>2</b>	9.2 Typical Application .....	<b>12</b>
<b>5 Device Comparison Table</b> .....	<b>2</b>	9.3 Additional Application Circuits.....	<b>16</b>
<b>6 Pin Configuration and Functions</b> .....	<b>3</b>	<b>10 Power Supply Recommendations</b> .....	<b>20</b>
<b>7 Specifications</b> .....	<b>4</b>	<b>11 Layout</b> .....	<b>21</b>
7.1 Absolute Maximum Ratings .....	<b>4</b>	11.1 Layout Guidelines .....	<b>21</b>
7.2 ESD Ratings .....	<b>4</b>	11.2 Layout Example .....	<b>21</b>
7.3 Recommended Operating Conditions.....	<b>4</b>	<b>12 Device And Documentation Support</b> .....	<b>22</b>
7.4 Thermal Information .....	<b>4</b>	12.1 Device Support.....	<b>22</b>
7.5 Electrical Characteristics.....	<b>5</b>	12.2 Receiving Notification of Documentation Updates	<b>22</b>
7.6 Typical Characteristics.....	<b>6</b>	12.3 Community Resources.....	<b>22</b>
<b>8 Detailed Description</b> .....	<b>9</b>	12.4 Trademarks .....	<b>22</b>
8.1 Overview .....	<b>9</b>	12.5 Electrostatic Discharge Caution.....	<b>22</b>
8.2 Functional Block Diagram .....	<b>9</b>	12.6 Glossary .....	<b>22</b>
8.3 Feature Description.....	<b>10</b>	<b>13 Mechanical, Packaging, and Orderable Information</b> .....	<b>22</b>

## 4 Revision History

NOTE: Page numbers for previous revisions may differ from page numbers in the current version.

Changes from Revision A (March 2011) to Revision B	Page
• Added <i>Device Information</i> and <i>Pin Configuration and Functions</i> sections, <i>Device Comparison</i> and <i>ESD Ratings</i> tables, <i>Feature Description</i> , <i>Device Functional Modes</i> , <i>Application and Implementation</i> , <i>Power Supply Recommendations</i> , <i>Layout</i> , <i>Device and Documentation Support</i> , and <i>Mechanical, Packaging, and Orderable Information</i> sections; minor changes to page 1 to delete redundant content .....	<b>1</b>
• Deleted the <i>Ordering Information</i> table, see POA at the end of the data sheet .....	<b>1</b>

Changes from Original (February) to Revision A	Page
• Deleted Voltage Range spec for "all other pins" in the Absolute Maximum Ratings table. ....	<b>4</b>
• Added $F_{PWM}$ spec. for PWM dimming frequency at $D_{PWM} \geq 1\%$ and $D_{PWM} \geq 5\%$ .....	<b>4</b>

## 5 Device Comparison Table

	TPS61181A	TPS61180
Input voltage range	5 V to 24 V	5 V to 24 V
Number of LED channels	6	6
LED current/channel	30	25
I2C/SPI support	No	No

## 6 Pin Configuration and Functions

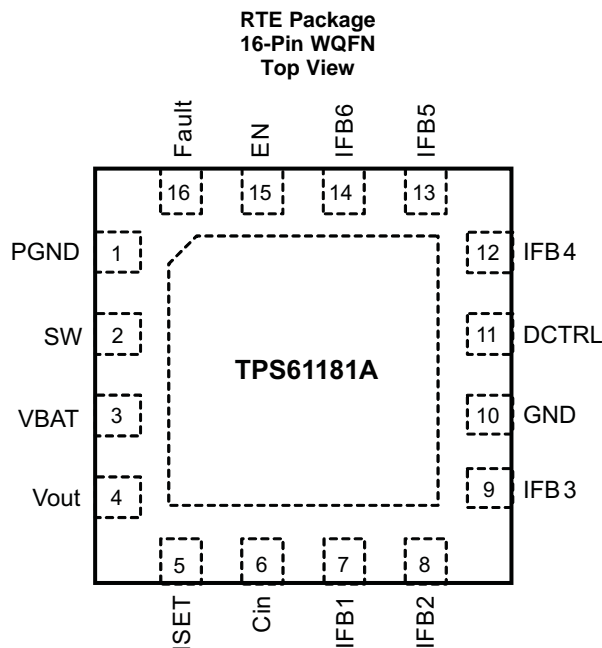

### Pin Functions

PIN		I/O	DESCRIPTION
NO.	NAME		
1	PGND	I	Power ground of the device. Internally, it connects to the source of the PWM switch.
2	SW	I	This pin connects to the drain of the internal PWM switch, external Schottky diode and inductor.
3	V <sub>BAT</sub>	I	This pin is connected to the battery supply. It provides the pullup voltage for the Fault pin and battery voltage signal. This is also the input to the internal LDO.
4	V <sub>O</sub>	O	This pin monitors the output of the boost regulator. Connect this pin to the anode of the WLED strings.
5	ISET	I	The resistor on this pin programs the WLED output current.
6	C <sub>in</sub>	I	Supply voltage of the device. It is the output of the internal LDO. Connect 0.1- $\mu$ F bypass capacitor to this pin.
7, 8, 9 12, 13, 14	IFB1-IFB3 IFB4-IFB6	I	Current sink regulation inputs. They are connected to the cathode of WLEDs. The PWM loop regulates the lowest V <sub>IFB</sub> to 400 mV. Each channel is limited to 30-mA current.
10	GND	I	Signal ground of the device.
11	DCTRL	I	Dimming control logic input. The dimming frequency range is 100 Hz to 1 kHz.
15	EN	I	The enable pin to the device. A logic high signal turns on the internal LDO and enables the device. Therefore, do not connect the EN pin to the C <sub>in</sub> pin.
16	Fault	I	Gate driver output for an external PFET used for fault protection. It can also be used as signal output for system fault report.

## 7 Specifications

### 7.1 Absolute Maximum Ratings

 over operating free-air temperature range (unless otherwise noted) <sup>(1)</sup>

		MIN	MAX	UNIT
Voltage range <sup>(2)</sup>	V <sub>BAT</sub> and Fault	-0.3	24	V
	C <sub>IN</sub> and ISET	-0.3	3.6	
	SW and V <sub>O</sub>	-0.3	40	
	IFB1 to IFB6, EN and DCTRL	-0.3	20	
Continuous power dissipation		See <a href="#">Thermal Information</a>		
Operating junction temperature range		-40	150	°C
Storage temperature range		-65	150	

- (1) Stresses beyond those listed under *Absolute Maximum Ratings* may cause permanent damage to the device. These are stress ratings only, which do not imply functional operation of the device at these or any other conditions beyond those indicated under *Recommended Operating Conditions*. Exposure to absolute-maximum-rated conditions for extended periods may affect device reliability.
- (2) All voltage values are with respect to network ground terminal.

### 7.2 ESD Ratings

		VALUE	UNIT
V <sub>(ESD)</sub> Electrostatic discharge	Human-body model (HBM), per ANSI/ESDA/JEDEC JS-001 <sup>(1)</sup>	±3000	V
	Charged-device model (CDM), per JEDEC specification JESD22-C101 <sup>(2)</sup>	±200	
	Machine mode (MM)	1000	

- (1) JEDEC document JEP155 states that 500-V HBM allows safe manufacturing with a standard ESD control process.
- (2) JEDEC document JEP157 states that 250-V CDM allows safe manufacturing with a standard ESD control process.

### 7.3 Recommended Operating Conditions

		MIN	NOM	MAX	UNIT
V <sub>BAT</sub>	Battery input voltage range	4.5		24	V
V <sub>O</sub>	Output voltage range	V <sub>in</sub>		38	V
L	Inductor	4.7		10	μH
C <sub>O</sub>	Output capacitor	2.2		10	μF
F <sub>PWM</sub>	PWM dimming frequency at D <sub>PWM</sub> ≥ 1%	0.1		1	kHz
	PWM dimming frequency at D <sub>PWM</sub> ≥ 5%	1		5	
T <sub>A</sub>	Operating ambient temperature	-40		85	°C
T <sub>J</sub>	Operating junction temperature	-40		125	°C

### 7.4 Thermal Information

THERMAL METRIC <sup>(1)</sup>		TPS61181A	UNIT
		RTE (WQFN)	
		16 PINS	
R <sub>θJA</sub>	Junction-to-ambient thermal resistance	43.1	°C/W
R <sub>θJctop</sub>	Junction-to-case (top) thermal resistance	38.3	°C/W
R <sub>θJB</sub>	Junction-to-board thermal resistance	14.6	°C/W
R <sub>ψJT</sub>	Junction-to-top characterization parameter	0.4	°C/W
R <sub>ψJB</sub>	Junction-to-board characterization parameter	14.4	°C/W
R <sub>θJcbot</sub>	Junction-to-case (bottom) thermal resistance	3.6	°C/W

- (1) For more information about traditional and new thermal metrics, see the [Semiconductor and IC Package Thermal Metrics](#) application report.

## 7.5 Electrical Characteristics

$V_{BAT} = 10.8\text{ V}$ ,  $0.1\ \mu\text{F}$  at  $C_{in}$ ,  $EN = \text{logic high}$ ,  $IFB\ \text{current} = 20\ \text{mA}$ ,  $IFB\ \text{voltage} = 500\ \text{mV}$ ,  $T_A = -40^\circ\text{C}$  to  $85^\circ\text{C}$ , typical values are at  $T_A = 25^\circ\text{C}$  (unless otherwise noted).

PARAMETER		TEST CONDITIONS	MIN	TYP	MAX	UNIT
<b>SUPPLY CURRENT</b>						
$V_{BAT}$	Battery input voltage range		4.5		24	V
$V_{Cin}$	$C_{in}$ pin output voltage		2.7	3.15	3.6	V
$I_{q\_bat}$	Operating quiescent current into $V_{BAT}$	Device enable, switching no load, $V_{IN} = 24\ \text{V}$			3	mA
$I_{Q\_sw}$	Operating quiescent current into $V_O$	$V_O = 35\ \text{V}$			60	$\mu\text{A}$
$I_{SD}$	Shutdown current	$EN = \text{GND}$		2	18	$\mu\text{A}$
$V_{bat\_UVLO}$	$V_{BAT}$ undervoltage lockout threshold	$V_{BAT}$ rising			4.45	V
		$V_{BAT}$ falling	3.9			
$V_{bat\_hys}$	$V_{BAT}$ undervoltage lockout hysteresis	$V_{BAT}$ rising – $V_{BAT}$ falling		220		mV
<b>EN AND DCTRL</b>						
$V_H$	EN pin logic high voltage		2			V
$V_L$	EN pin logic low voltage				0.8	V
$V_H$	DCTRL pin logic high voltage		2			V
$V_L$	DCTRL pin logic low voltage				0.8	V
$R_{PD}$	Pulldown resistor on both pins	$V_{EN, DCTRL} = 2\ \text{V}$	400	800	1600	k $\Omega$
<b>CURRENT REGULATION</b>						
$V_{ISET}$	ISET pin voltage		1.204	1.229	1.253	V
$K_{ISET}$	Current multiple $I_{out}/ISET$	ISET current = $20\ \mu\text{A}$	970	1000	1030	
IFB	Current accuracy	ISET current = $20\ \mu\text{A}$	19.4	20	20.6	mA
$K_m$	$(I_{max} - I_{min}) / I_{AVG}$	ISET current = $20\ \mu\text{A}$		1%	2.5%	
$I_{leak}$	IFB pin leakage current	IFB voltage = 20 V on all pins			3	$\mu\text{A}$
$I_{IFB\_MAX}$	Current sink max output current	IFB = 500 mV	30			mA
<b>BOOST OUTPUT REGULATION</b>						
$V_{IFB\_L}$	$V_O$ dial up threshold	ISET current = $20\ \mu\text{A}$		400		mV
$V_{IFB\_H}$	$V_O$ dial down threshold	ISET current = $20\ \mu\text{A}$		700		mV
$V_{reg\_L}$	Min $V_O$ regulation voltage				16	V
$V_{o\_step}$	$V_O$ stepping voltage			100	150	mV
<b>POWER SWITCH</b>						
$R_{PWM\_SW}$	PWM FET on-resistance			0.2	0.45	$\Omega$
$R_{start}$	Start up charging resistance	$V_O = 0\ \text{V}$	100		300	$\Omega$
$V_{start\_r}$	Isolation FET start-up threshold	$V_{IN} - V_O$ , $V_O$ ramp up		1.2	2	V
$I_{LN\_NFET}$	PWM FET leakage current	$V_{SW} = 35\ \text{V}$			1	$\mu\text{A}$

## Electrical Characteristics (continued)

$V_{BAT} = 10.8\text{ V}$ ,  $0.1\ \mu\text{F}$  at  $C_{in}$ , EN = logic high, IFB current = 20 mA, IFB voltage = 500 mV,  $T_A = -40^\circ\text{C}$  to  $85^\circ\text{C}$ , typical values are at  $T_A = 25^\circ\text{C}$  (unless otherwise noted).

PARAMETER	TEST CONDITIONS	MIN	TYP	MAX	UNIT		
<b>OSCILLATOR</b>							
$f_S$	Oscillator frequency	0.9	1	1.2	MHz		
$D_{max}$	Maximum duty cycle	IFB = 0 V		94%			
$D_{min}$	Minimum duty cycle			7%			
<b>OS, SC, OVP AND SS</b>							
$I_{LIM}$	N-channel MOSFET current limit	D = $D_{max}$		3	A		
$V_{ovp}$	$V_O$ overvoltage threshold	Measured on the $V_O$ pin		38	39	V	
$V_{ovp\_IFB}$	IFB overvoltage threshold	Measured on the IFBx pin		15	17	V	
$V_{sc}$	Short-circuit detection threshold	$V_{IN} - V_O$ , $V_O$ ramp down		1.7	2.5	V	
$V_{sc\_dly}$	Short-circuit detection delay during start up			32		ms	
<b>FAULT OUTPUT</b>							
$V_{fault\_high}$	Fault high voltage	Measured as $V_{BAT} - V_{Fault}$		0.1		V	
$V_{fault\_low}$	Fault low voltage	Measured as $V_{BAT} - V_{Fault}$ , sink 0.1 mA $V_{IN} = 15\text{ V}$		6	8	10	V
<b>THERMAL SHUTDOWN</b>							
$T_{shutdown}$	Thermal shutdown threshold			160		$^\circ\text{C}$	
$T_{hysteresis}$	Thermal shutdown threshold hysteresis			15		$^\circ\text{C}$	

## 7.6 Typical Characteristics

Table 1. Table of Graphs

Description (Reference to application circuit in Figure 16)	Figure	
Dimming Linearity	$V_{bat} = 10.8\text{ V}$ ; $V_O = 28.6\text{ V}$ , 9 LEDs; $I_{set} = 20\ \mu\text{A}$ ; PWM Freq = 1 kHz	Figure 1
Dimming Linearity	$V_{bat} = 10.8\text{ V}$ ; $V_O = 28.6\text{ V}$ , 9 LEDs; $I_{set} = 20\ \mu\text{A}$ ; PWM Freq = 200 Hz	Figure 2
Output Ripple	$V_O = 28.6\text{ V}$ ; $I_{set} = 20\ \mu\text{A}$ ; PWM Freq = 200 Hz; Duty = 50%	Figure 3
Switching Waveform	$V_{bat} = 10.8\text{ V}$ ; $I_{set} = 20\ \mu\text{A}$	Figure 4
Output Ripple at PWM Dimming	$V_{bat} = 10.8\text{ V}$ ; $I_{set} = 20\ \mu\text{A}$ ; PWM Freq = 200 Hz; Duty = 50%; $C_O = 4.7\ \mu\text{F}$	Figure 5
Short Circuit Protection	$V_{bat} = 10.8\text{ V}$ ; $I_{set} = 20\ \mu\text{A}$	Figure 6
Open WLED Protection	$V_{bat} = 10.8\text{ V}$ ; $I_{set} = 20\ \mu\text{A}$	Figure 7
Startup Waveform	$V_{bat} = 10.8\text{ V}$ ; $I_{set} = 20\ \mu\text{A}$	Figure 8
DC Load Efficiency	$V_{bat} = 5\text{ V}$ , 10.8 V, 19 V; $V_O = 28.6\text{ V}$ , 9 LEDs; L = 10 $\mu\text{H}$	Figure 10
DC Load Efficiency	$V_{bat} = 5\text{ V}$ , 10.8 V, 19 V; $V_O = 31.7\text{ V}$ , 10 LEDs; L = 10 $\mu\text{H}$	Figure 11
PWM Dimming Efficiency	$V_{bat} = 5\text{ V}$ , 10.8 V and 19 V; $V_O = 25.5\text{ V}$ , 8 LEDs; PWM Freq = 1 kHz	Figure 12
PWM Dimming Efficiency	$V_{bat} = 5\text{ V}$ , 10.8 V and 19 V; $V_O = 28.6\text{ V}$ , 9 LEDs; PWM Freq = 1 kHz	Figure 13
PWM Dimming Efficiency	$V_{bat} = 5\text{ V}$ , 10.8 V and 19 V; $V_O = 31.7\text{ V}$ , 10 LEDs; PWM Freq = 1 kHz	Figure 14
PWM Dimming Efficiency	$V_{bat} = 5\text{ V}$ , 10.8 V and 19 V; $V_O = 34.8\text{ V}$ , 11 LEDs; PWM Freq = 1 kHz	Figure 15

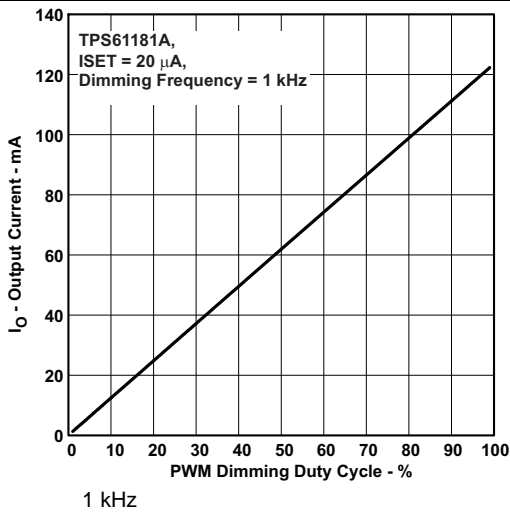

Figure 1. PWM Dimming Linearity

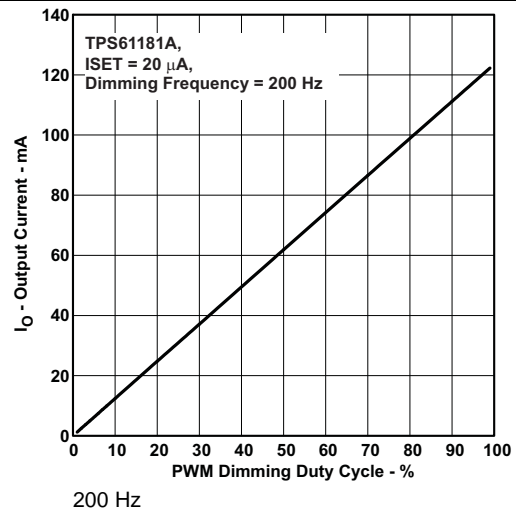
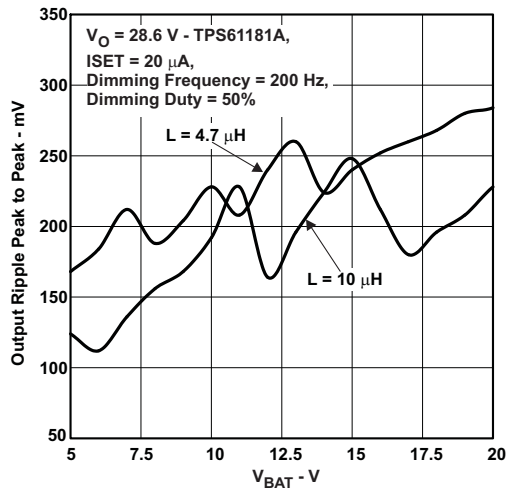

Figure 2. PWM Dimming Linearity



$C_{OUT} = 4.7$   $\mu$ F

Figure 3. PWM Dimming Output Ripple vs Input Voltage

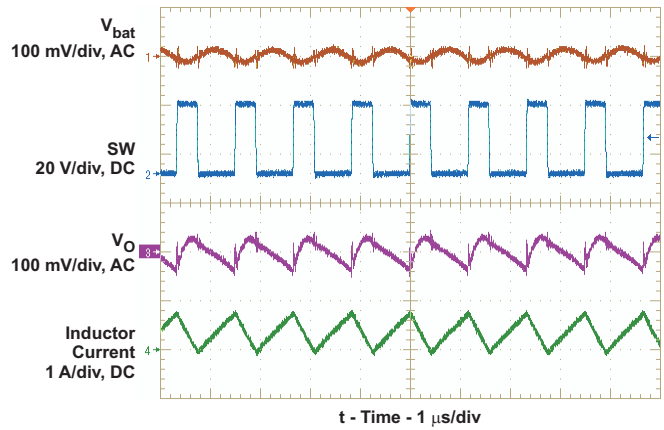
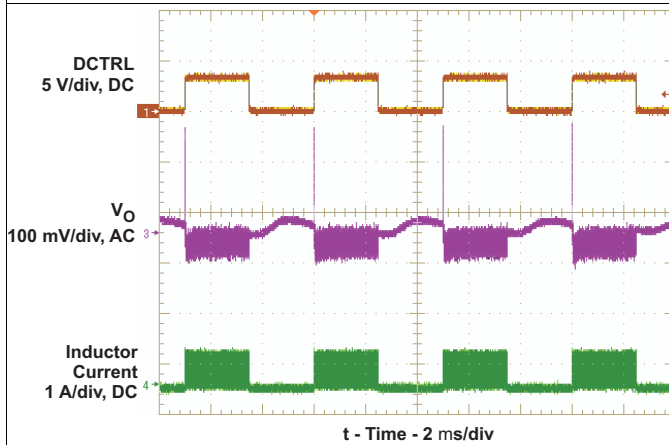

Figure 4. Switching Waveform



$C_{OUT} = 4.7$   $\mu$ F

Figure 5. Output Ripple at PWM Dimming

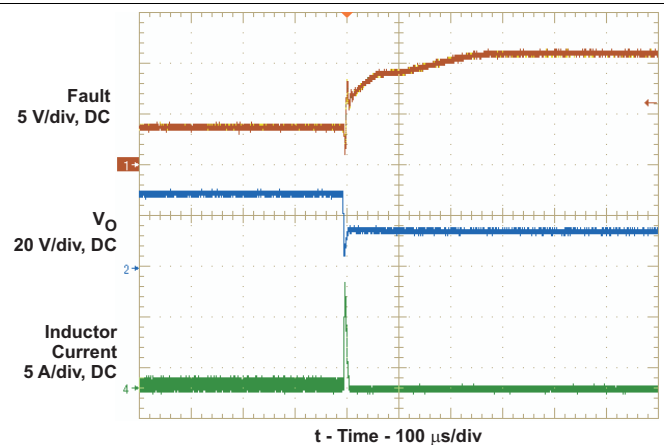
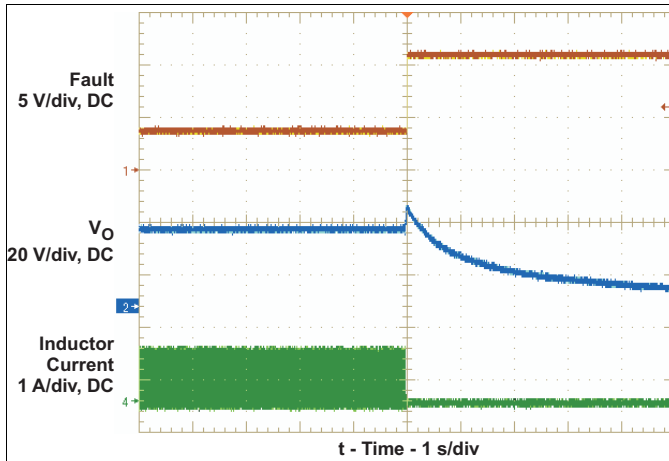

Figure 6. Output Short Protection

**TPS61181A**

SLVSN6B – FEBRUARY 2011 – REVISED SEPTEMBER 2016

www.ti.com



**Figure 7. Open WLED Protection**

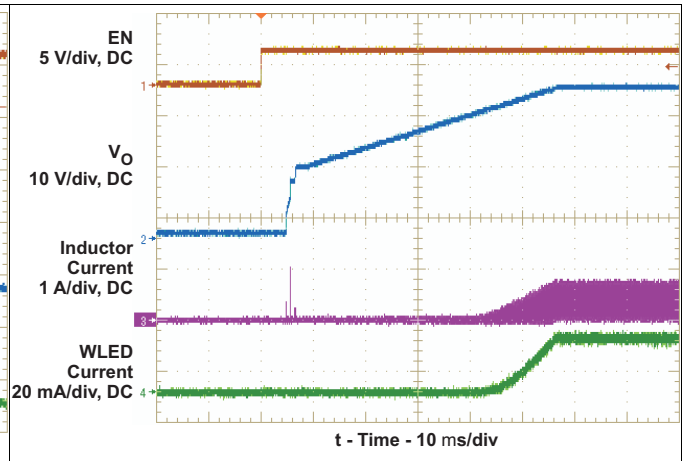

**Figure 8. Start-up Waveform**



## 8.3 Feature Description

### 8.3.1 Supply Voltage

The TPS61181A has built-in LDO linear regulator to supply the device analog and logic circuits. The LDO is powered up when the EN pin is high. The output of the LDO is connected to the Cin pin. A 0.1- $\mu$ F bypass capacitor is required for stable operation of the LDO. Do not connect the Cin pin to the EN pin because this prevents the device from starting up. In addition, avoid connecting the Cin pin to any other circuit as this could introduce noise into the device supply voltage.

The  $V_{BAT}$  connects to the input of the internal LDO, and powers the device. The voltage on the  $V_{BAT}$  pin is also the reference for the pull-up circuit of the Fault pin. In addition, it serves as the input signal to the short-circuit protection. There is an undervoltage lockout on the  $V_{BAT}$  pin which disables the device when its voltage reduces to 4.2 V (typical). The device restarts when the  $V_{BAT}$  pin voltage recovers by 220 mV.

### 8.3.2 Boost Regulator

The boost regulator is controlled by current mode PWM, and loop compensation is integrated inside the device. The internal compensation ensures stable output over the full input and output voltage range. The TPS61181A switches at 1 MHz which optimize boost converter efficiency and voltage ripple with a small form factor inductor and output capacitor.

The output voltage of the boost regulator is automatically set by the device to minimize the voltage drop across the IFB pins. The device automatically regulates the lowest IFB pin to 400 mV, and consistently adjusts the boost output voltage to account for any changes of the LED forward voltages.

When the output voltage is too close to the input, the boost regulator may not be able to regulate the output due to the limitation of minimum duty cycle. In this case, increase the number of WLED in series or include series ballast resistors in order to provide enough headroom for the boost operation.

The TPS61181A boost regulator cannot regulate its output to voltages below 15 V.

### 8.3.3 Enable and Start-Up

A logic high signal on the EN pin turns on the device. For the TPS61181A, taking EN high turns on the internal LDO linear regulator which provides supply to the device current. Then, an internal resistor,  $R_{start}$  (start up charging resistor) is connected between the  $V_{BAT}$  pin and  $V_O$  pin to charge the output capacitor toward the  $V_{BAT}$  pin voltage. The Fault pin outputs high during this time, and thus the external isolation PFET is turned off. Once the  $V_O$  pin voltage is within 2 V (isolation FET start up threshold) of the  $V_{BAT}$  pin voltage,  $R_{start}$  is open, and the Fault pin pulls down the gate of the PFET and connects the  $V_{BAT}$  voltage to the boost regulator. This operation is to prevent the in-rush current due to charging the output capacitor.

Once the isolation FET is turned on, the device starts PWM switching to raise the output voltage above  $V_{BAT}$ . Soft-start is implemented by gradually ramping up the reference voltage of the error amplifier to prevent voltage overshoot and in-rush current. See the start-up waveform of a typical example, [Figure 8](#).

Pulling the EN pin low immediately shuts down the device, resulting in the device consuming less than 50  $\mu$ A in the shutdown mode.

### 8.3.4 Overcurrent, Overvoltage, and Short-Circuit Protection

The TPS61181A has pulse-by-pulse over-current limit of 1.5 A (minimum). The PWM switch turns off when the inductor current reaches this current threshold. The PWM switch remains off until the beginning of the next switching cycle. This protects the device and external components under overload conditions. When there is sustained over-current condition for more than 16 ms (under 100% dimming duty cycle), the device turns off and requires POR or the EN pin toggling to restart.

Under severe overload and/or short circuit conditions, the  $V_O$  pin can be pulled below the input ( $V_{BAT}$  pin). Under this condition, the current can flow directly from  $V_{BAT}$  to the WLED through the inductor and schottky diode. Turning off the PWM switch alone does not limit current anymore. In this case, the TPS61181A detects the output voltage is 1.7 V ( $V_{sc}$ , short circuit detection threshold) below the input voltage, turns off the isolation FET, and shuts down the device. The device restarts after input power-on reset ( $V_{BAT}$  POR) or EN pin logic toggling.

## Feature Description (continued)

During device start up, if there is short-circuit condition on the boost converter output, the output capacitor will not be charged to within 2 V of  $V_{BAT}$  through  $R_{start}$ . After 32 ms ( $V_{sc\_dly}$ , short circuit detection delay during start-up), the TPS61181A shuts down and does not restart until there is  $V_{BAT}$  POR or EN pin toggling. The isolation FET is never turned on under the condition.

If one of the WLED strings is open, the boost output rises to overvoltage threshold (39V typical). The TPS61181A detects the open WLED string by sensing no current in the corresponding IFB pin. As a result, the device removes the open IFB pin from the voltage feedback loop. Subsequently, the output voltage drops down and is regulated to a voltage for the connected WLED strings. The IFB current of the connected WLED strings keep in regulation during the whole transition. The device only shuts down if it detects that all of the WLED strings are open.

If the overvoltage threshold is reached, but the current sensed on the IFB pin is below the regulation target, the device regulates the boost output at the overvoltage threshold. This operation could occur when the WLED is turned on under cold temperature, and the forward voltages of the WLEDs exceed the overvoltage threshold. Maintaining the WLED current allows the WLED to warm up and their forward voltages to drop below the overvoltage threshold.

If any IFB pin voltage exceeds IFB overvoltage threshold (17 V typical), the device turns off the corresponding current sink and removes this IFB pin from  $V_O$  regulation loop. The current regulation of the remaining IFB pins is not affected. This condition often occurs when there are several shorted WLEDs in one string. WLED mismatch typically does not create such large voltage difference among WLED strings.

### 8.3.5 IFB Pin Unused

If the application requires less than 6 WLED strings, one can easily disable unused IFB pins. The TPS61181A simply requires leaving the unused IFB pin open or shorting it to ground. If the IFB pin is open, the boost output voltage ramps up to  $V_O$  overvoltage threshold during start up. The device then detects the zero current string, and removes it from the feedback loop. If the IFB pin is shorted to ground, the device detects the short immediately after device enable, and the boost output voltage does not go up to  $V_O$  overvoltage threshold. Instead, it ramps to the regulation voltage after soft start.

## 8.4 Device Functional Modes

### 8.4.1 Current Program and PWM Dimming

The six current sink regulators can each provide a maximum of 30 mA. The IFB current must be programmed to maximum WLED current using the ISET pin resistor and [Equation 1](#).

$$I_{FB} = K_{ISET} \frac{V_{ISET}}{R_{ISET}}$$

where

- $K_{ISET}$  = Current multiple (1000 typical)
  - $V_{ISET}$  = ISET pin voltage (1.229 V typical)
  - $R_{ISET}$  = ISET pin resistor
- (1)

The TPS61181A has six built-in precise current sink regulators. The current matching among the current sinks at 20-mA current through is below 2.5%. This means the differential value between the maximum and minimum current of the six current sinks divided by the average current of the six is less than 2.5%.

The WLED brightness is controlled by the PWM signal on the DCTRL pin. The frequency and duty cycle of the DCTRL signal is replicated on the IFB pin current. Keep the dimming frequency in the range of 100 Hz to 1 kHz to avoid screen flickering and maintain dimming linearity. Screen flickering may occur if the dimming frequency is below the range. The minimum achievable duty cycle increases with the dimming frequency. For example, while a 0.1% dimming duty cycle, giving a 1000:1 dimming range, is achievable at 100 Hz dimming frequency, only 1% duty cycle, giving a 100:1 dimming range, is achievable with a 1-KHz dimming frequency, and 5% dimming duty cycle is achievable with 5-KHz dimming frequency. The device could work at high dimming frequency like 20 KHz, but then only 15% duty cycle could be achievable. The TPS61181A is designed to minimize the AC ripple on the output capacitor during PWM dimming. Careful passive component selection is also critical to minimize AC ripple on the output capacitor. See [Application and Implementation](#) for more information.



## 9.2.2 Detailed Design Procedure

### 9.2.2.1 Inductor Selection

Because the selection of the inductor affects the steady-state operation of a power supply, transient behavior and loop stability, the inductor is the most important component in switching power regulator design. There are three specifications most important to the performance of the inductor: inductor value, DC resistance, and saturation current. The TPS61181A device is designed to work with inductor values between 4.7  $\mu\text{H}$  and 10  $\mu\text{H}$ . A 4.7- $\mu\text{H}$  inductor may be available in a smaller or lower profile package, while 10  $\mu\text{H}$  may produce higher efficiency due to lower inductor ripple. If the boost output current is limited by the overcurrent protection of the device, using a 10- $\mu\text{H}$  inductor can offer higher output current.

The internal loop compensation for the PWM control is optimized for the recommended component values, including typical tolerances. Inductor values can have  $\pm 20\%$  tolerance with no current bias. When the inductor current approaches saturation level, its inductance can decrease 20 to 35% from the zero current value depending on how the inductor vendor defines saturation

In a boost regulator, the inductor DC current can be calculated as:

$$I_{\text{dc}} = \frac{V_{\text{O}} \times I_{\text{O}}}{V_{\text{in}} \times \eta}$$

where

- $V_{\text{O}}$  = boost output voltage
- $I_{\text{O}}$  = boost output current
- $V_{\text{in}}$  = boost input voltage
- $\eta$  = power conversion efficiency, use 90% for TPS61181A applications (2)

The inductor current peak-to-peak ripple can be calculated as:

$$I_{\text{pp}} = \frac{1}{L \times \left( \frac{1}{V_{\text{O}} - V_{\text{bat}}} + \frac{1}{V_{\text{bat}}} \right) \times F_{\text{S}}}$$

where

- $I_{\text{pp}}$  = inductor peak-to-peak ripple
- $L$  = inductor value
- $F_{\text{S}}$  = switching frequency
- $V_{\text{bat}}$  = boost input voltage (3)

Therefore, the peak current seen by the inductor is

$$I_{\text{p}} = I_{\text{dc}} + \frac{I_{\text{pp}}}{2} \quad (4)$$

Select the inductor with saturation current at least 25% higher than the calculated peak current. To calculate the worse case inductor peak current, use minimum input voltage, maximum output voltage and maximum load current.

Regulator efficiency is dependent on the resistance of its high current path, switching losses associated with the PWM switch and power diode. Although the TPS61181A device have optimized the internal switch resistance, the overall efficiency still relies on the DC resistance (DCR) of the inductor; lower DCR improves efficiency. However, there is a trade off between DCR and inductor footprint. Furthermore, shielded inductors typically have a higher DCR than unshielded ones. [Table 3](#) lists recommended inductor models.

**Table 3. Recommended Inductors for TPS61181A**

	L ( $\mu$ H)	DCR TYPICAL (m $\Omega$ )	I <sub>sat</sub> (A)	SIZE (L×W×H mm)
<b>TOKO</b>				
A915AY-4R7M	4.7	38	1.87	5.2 × 5.2 × 3
A915AY-100M	10	75	1.24	5.2 × 5.2 × 3
<b>TDK</b>				
SLF6028T-4R7M1R6	4.7	28.4	1.6	6 × 6 × 2.8
SLF6028T-100M1R3	10	53.2	1.3	6 × 6 × 2.8

### 9.2.2.2 Output Capacitor Selection

During PWM brightness dimming, the load transient causes voltage ripple on the output capacitor. Since the PWM dimming frequency is in the audible frequency range, the ripple can produce audible noises on the output ceramic capacitor. There are two ways to reduce or eliminate this audible noise. The first option is to select PWM dimming frequency outside the audible range. This means the dimming frequency needs to be lower than 200 Hz or higher than 30 KHz. The potential issue with a very low dimming frequency is that WLED on/off can become visible and thus cause a flickering effect on the display. On the other hand, high dimming frequency can compromise the dimming range since the LED current accuracy and current match are difficult to maintain at low dimming duty cycle. The second option is to reduce the amount of the output ripple, and therefore minimize the audible noise.

The TPS61181A adopts a patented technology to limit output ripple even with small output capacitance. In a typical application, the output ripple is less than 200 mV during PWM dimming with a 4.7- $\mu$ F output capacitor, and the audible noise is not noticeable. The devices are designed to be stable with output capacitor down to 1  $\mu$ F. However, the output ripple will increase with lower output capacitor.

Care must be taken when evaluating the derating of a ceramic capacitor due to applied dc voltage, aging and over frequency. For example, larger form factor capacitors (in 1206 size) have their self resonant frequencies in the switching frequency range of the TPS61181A. So the effective capacitance is significantly lower. Therefore, it may be necessary to use small capacitors in parallel instead of one large capacitor.

### 9.2.2.3 Audible Noise Reduction

Ceramic capacitors can produce audible noise if the frequency of its AC voltage ripple is in the audible frequency range. In TPS61181A applications, both input and output capacitors are subject to AC voltage ripple during PWM brightness dimming. The device integrates a patented technology to minimize the ripple voltage, and thus audible noises.

To further reduce the audible noise, one effective way is to use two or three small size capacitors in parallel instead of one large capacitor. The application circuit in [Figure 16](#) uses two 2.2- $\mu$ F/25-V ceramic capacitors at the input and two 1- $\mu$ F/50-V ceramic capacitors at the output. All of the capacitors are in 0805 package. Although the output ripple during PWM dimming is higher than with one 4.7  $\mu$ F in a 1206 package, the overall audible noise is lower.

In addition, connecting a 10-nF/50V ceramic capacitor between the V<sub>O</sub> pin and IFB1 pin can further reduce the output AC ripple during the PWM dimming. Since this capacitor is subject to large AC ripple, choose a small package such as 0402 to prevent it from producing noise.

### 9.2.2.4 Isolation MOSFET Selection

The TPS61181A provides a gate driver to an external P-channel MOSFET which can be turned off during device shutdown or fault condition. This MOSFET can provide a true shutdown function, and also protect the battery from output short circuit conditions. The source of the PMOS must be connected to the input, and a pullup resistor is required between the source and gate of the FET to keep the FET off during device shutdown. To turn on the isolation FET, the Fault pin is pulled low, and clamped at 8 V below the V<sub>BAT</sub> pin voltage.

During device shutdown or fault condition, the isolation FET is turned off, and the input voltage is applied on the isolation MOSFET. During a short circuit condition, the catch diode (D2 in typical application circuit) is forward biased when the isolation FET is turned off. The drain of the isolation FET swings below ground. The voltage across the isolation FET can be momentarily greater than the input voltage. Therefore, select a 30-V MOSFET for a 24-V maximum input. The on resistance of the FET has a large impact on power conversion efficiency since the FET carries the input voltage. Select a MOSFET with  $R_{ds(on)}$  less than 100 m $\Omega$  to limit the power losses.

### 9.2.3 Application Curves

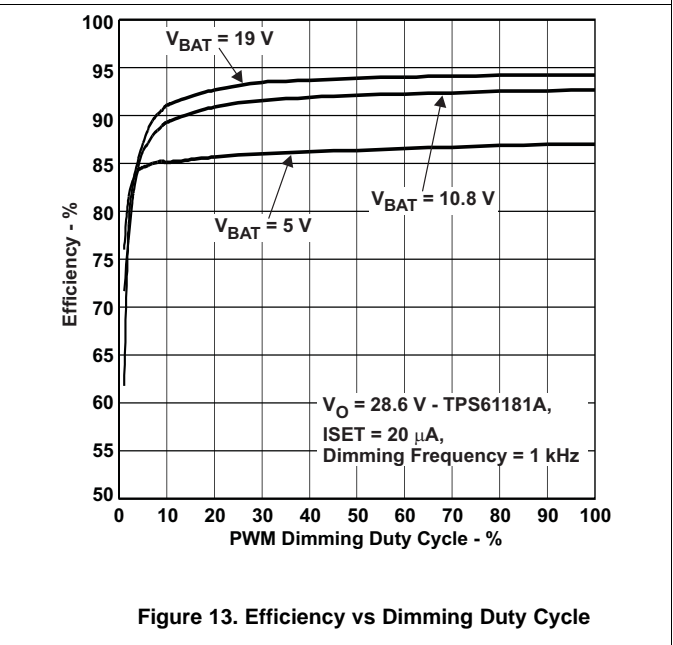
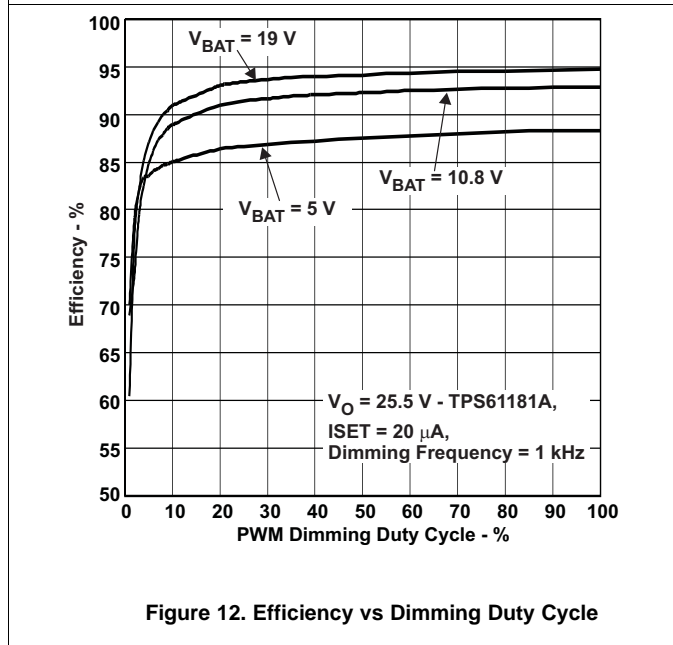
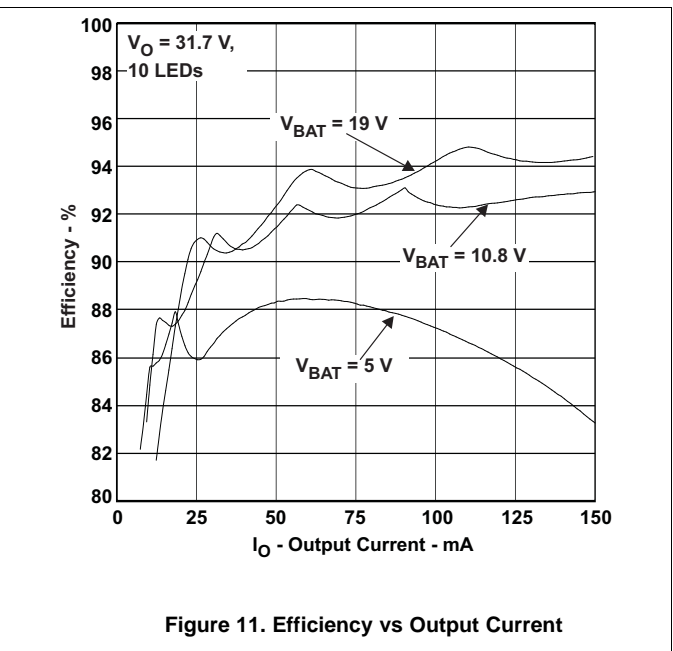
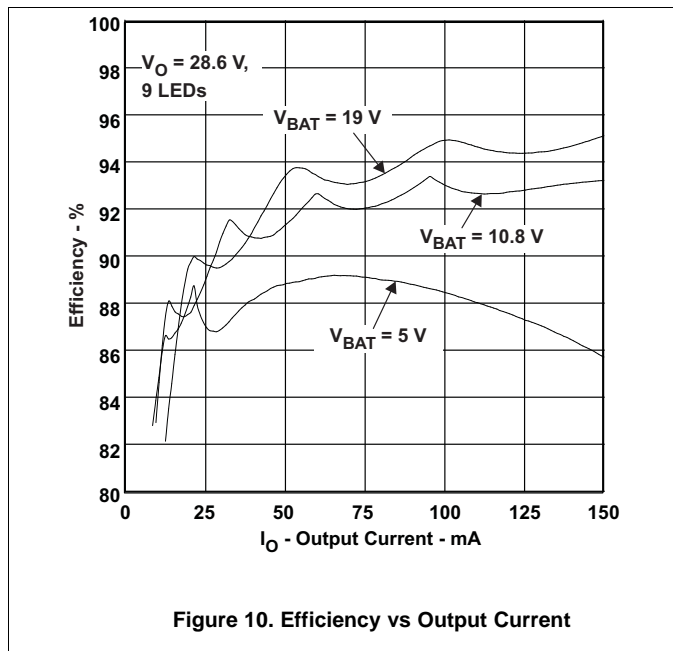

TPS61181A

SLVSAN6B – FEBRUARY 2011 – REVISED SEPTEMBER 2016

www.ti.com

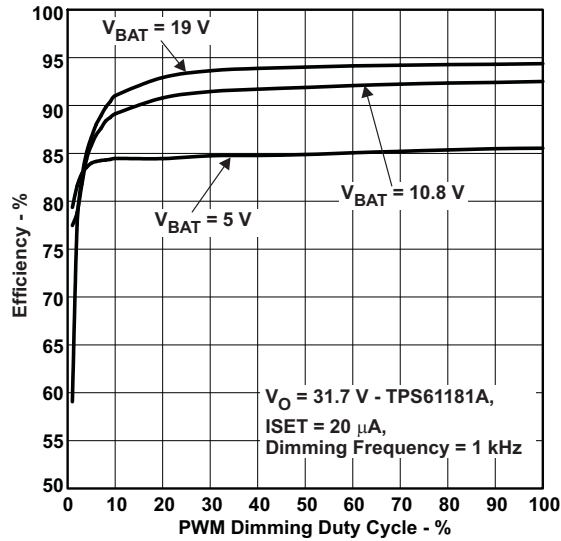

Figure 14. Efficiency vs Dimming Duty Cycle

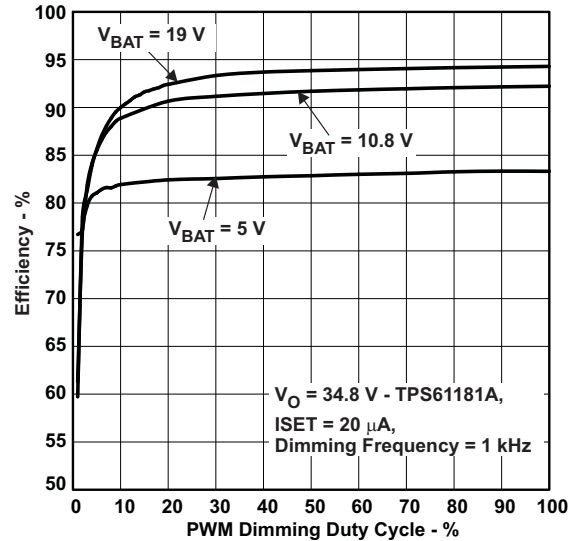
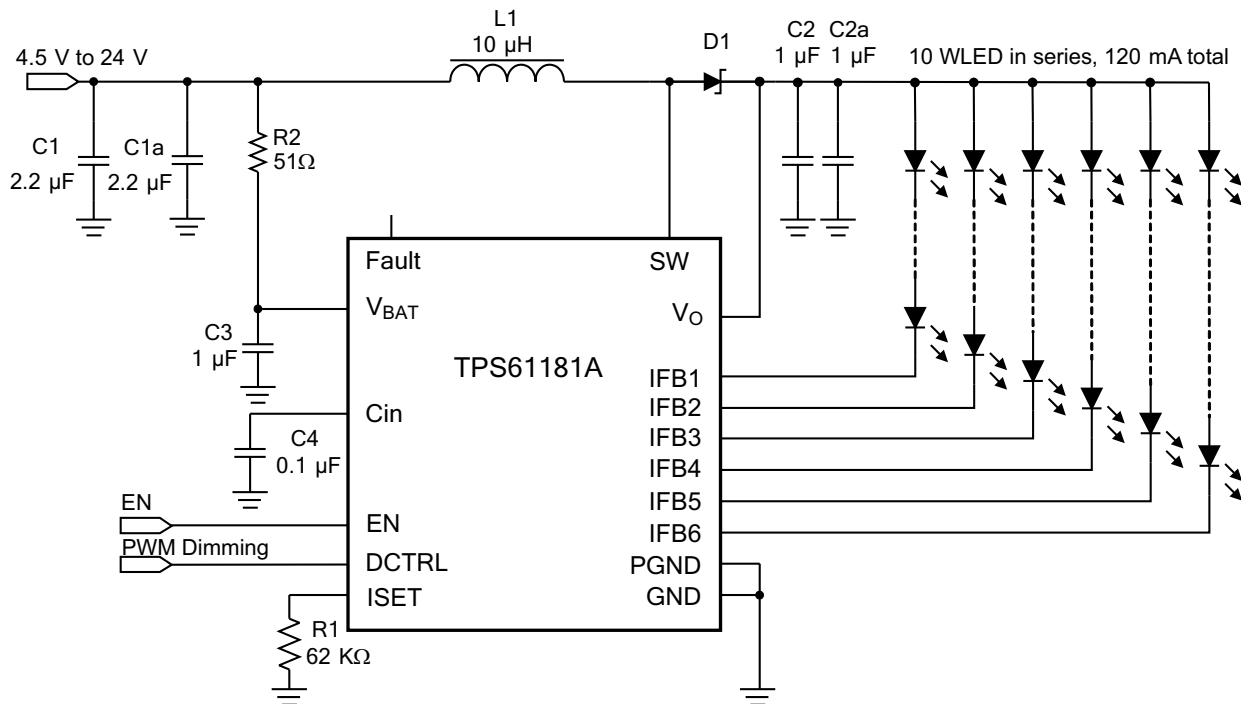

Figure 15. Efficiency vs Dimming Duty Cycle

9.3 Additional Application Circuits



C1, C1a: Murata GRM 219R61E225K  
 C2, C2a: Murata GRM 21BR71H105K  
 C3: Murata GRM 21BR71H105K  
 C4: Murata GRM 185R61A105K

L1: TOKO A 915AY-100 M  
 D1: VISHAY SS 2P5-E3/84A

Copyright © 2016, Texas Instruments Incorporated

Figure 16. Audible Noise-Reduction Circuit

Additional Application Circuits (continued)

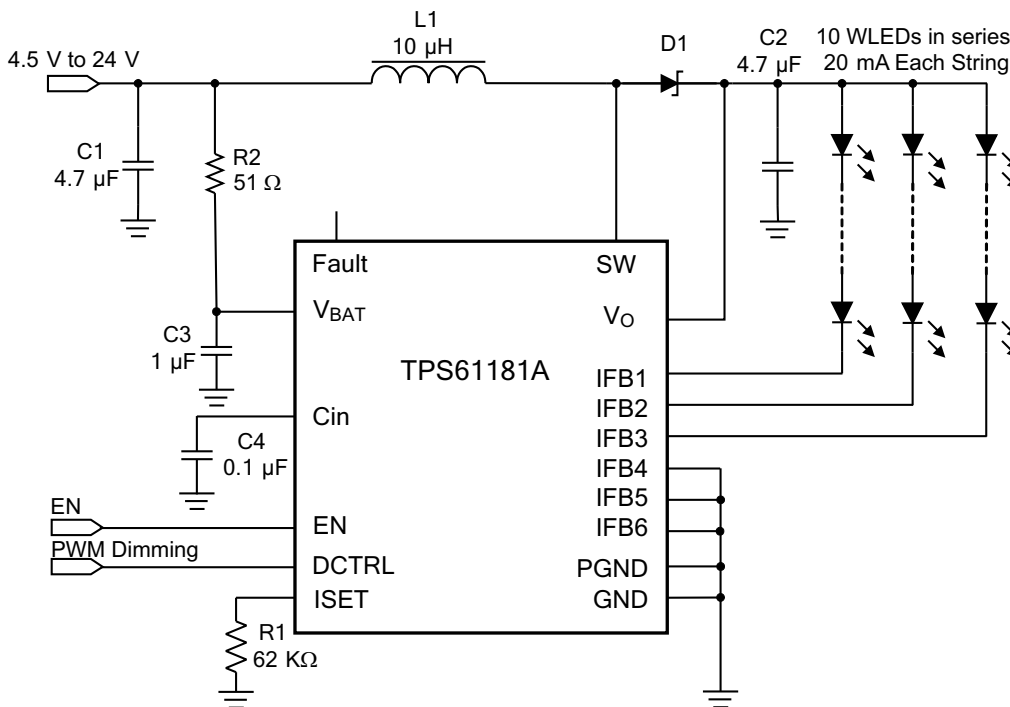

Copyright © 2016, Texas Instruments Incorporated

Figure 17. TPS61181A for Three Strings of LEDs

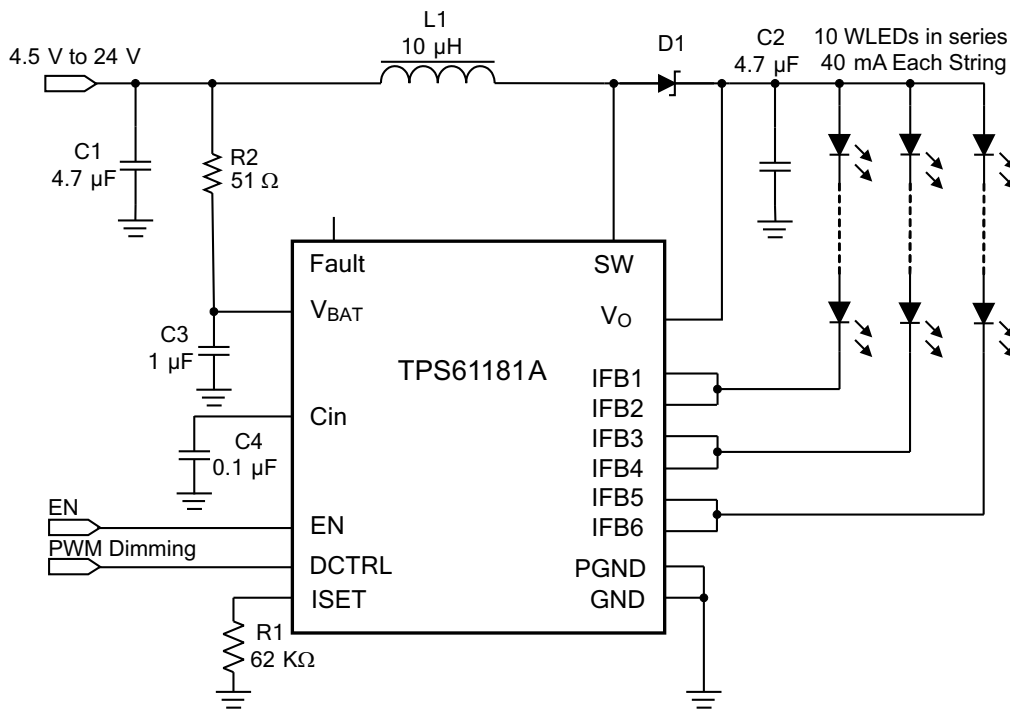

Copyright © 2016, Texas Instruments Incorporated

Figure 18. TPS61181A for Three Strings of LEDs With Double Current

Additional Application Circuits (continued)

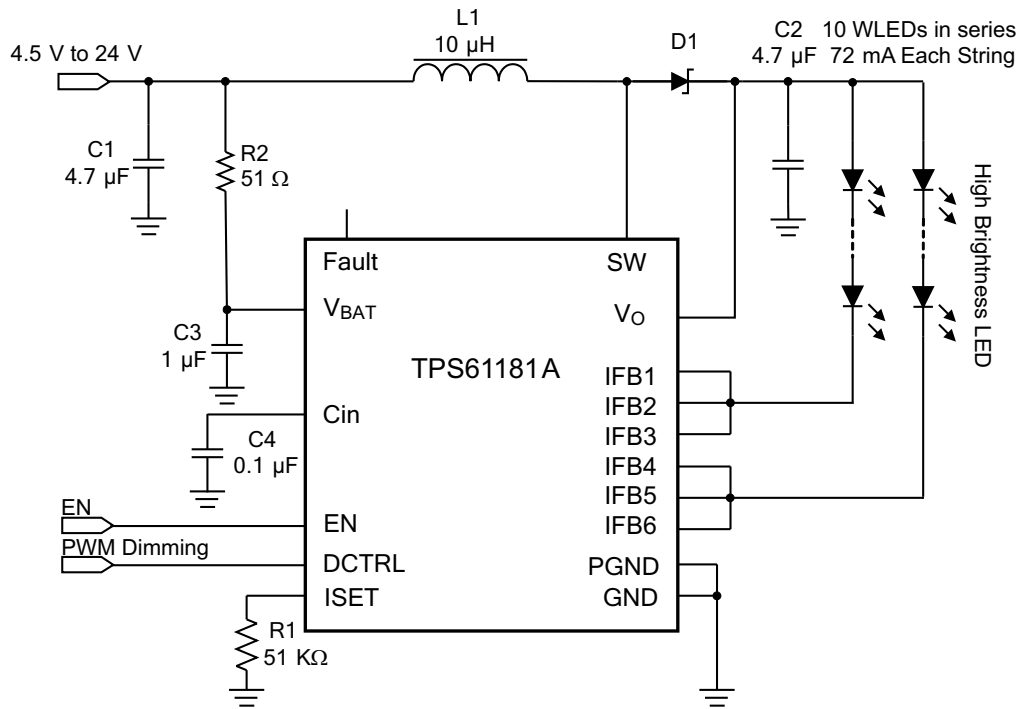

Copyright © 2016, Texas Instruments Incorporated

Figure 19. TPS61181A for Two Strings, High-Brightness LEDs Application

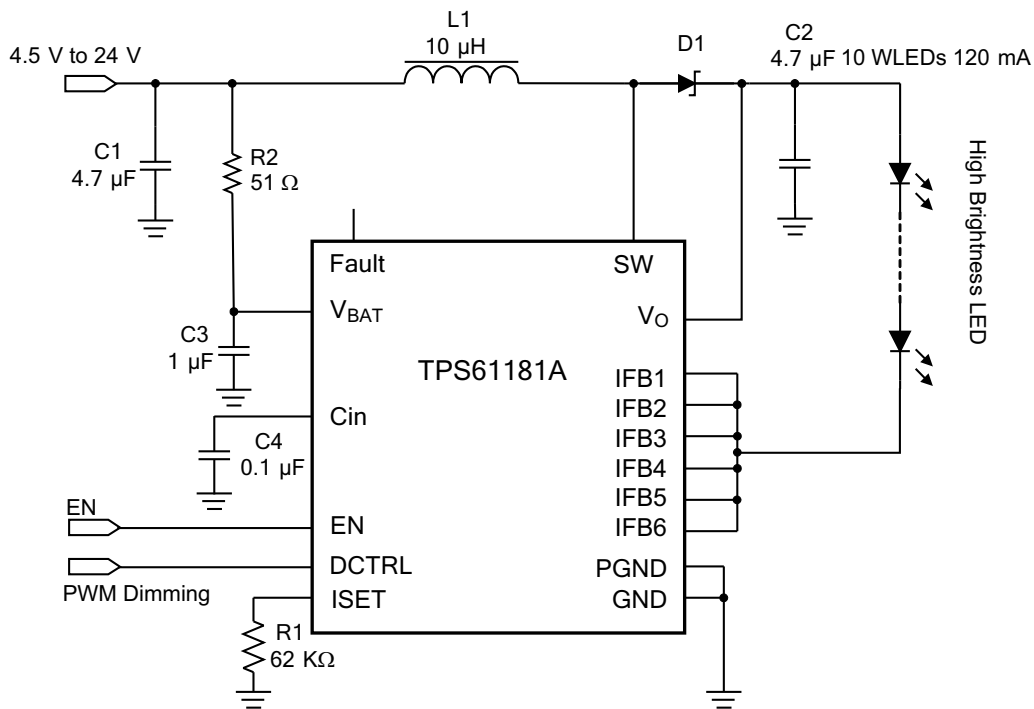

Copyright © 2016, Texas Instruments Incorporated

Figure 20. TPS61181A for One-String, High-Brightness LED Application

Additional Application Circuits (continued)

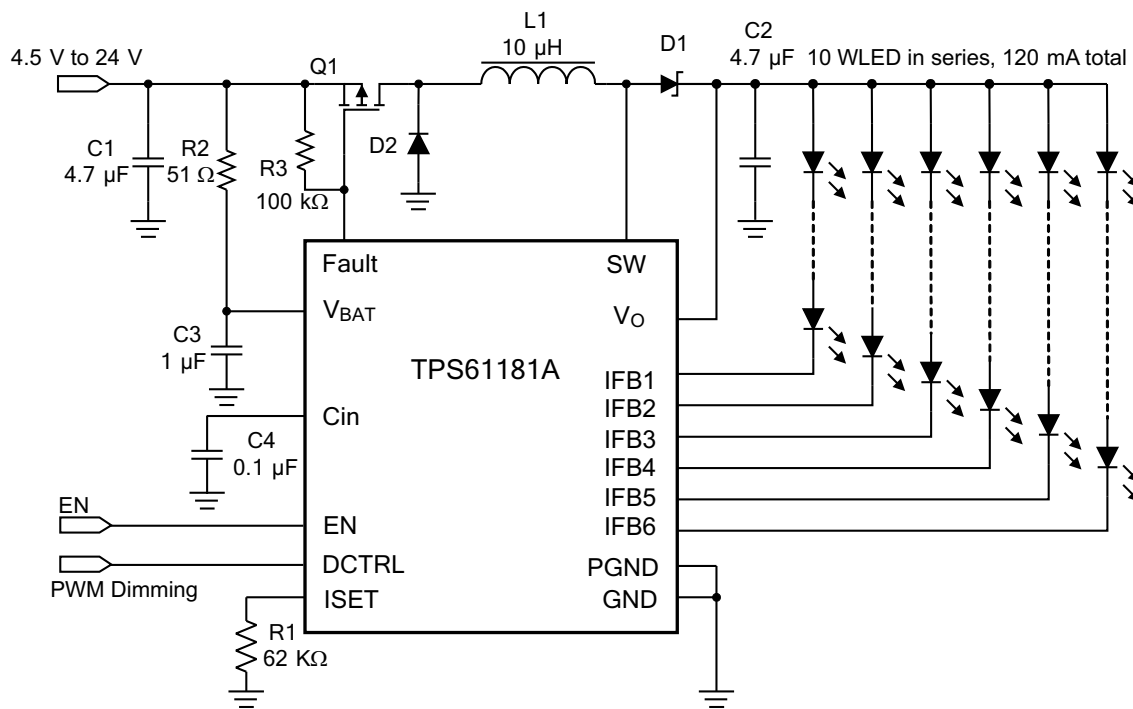

Copyright © 2016, Texas Instruments Incorporated

Figure 21. TPS61181A Driving External PFET for True Shutdown Application

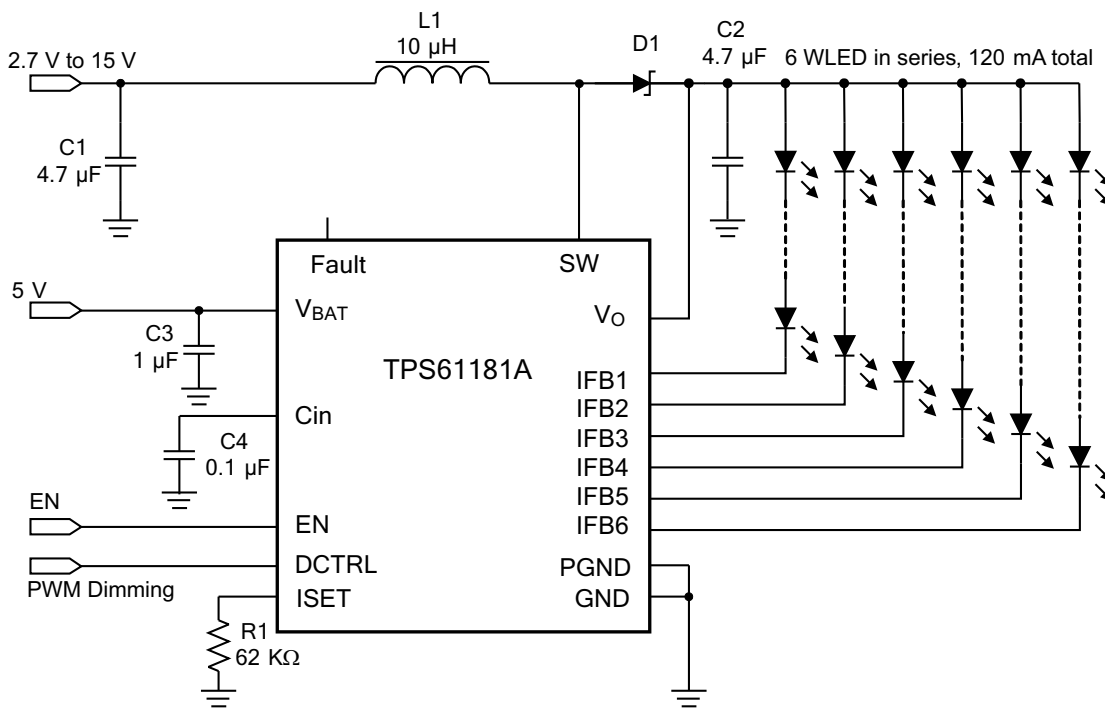

Copyright © 2016, Texas Instruments Incorporated

Figure 22. TPS61181A With Separate V<sub>BAT</sub> Power for Low Voltage-Input Application

Additional Application Circuits (continued)

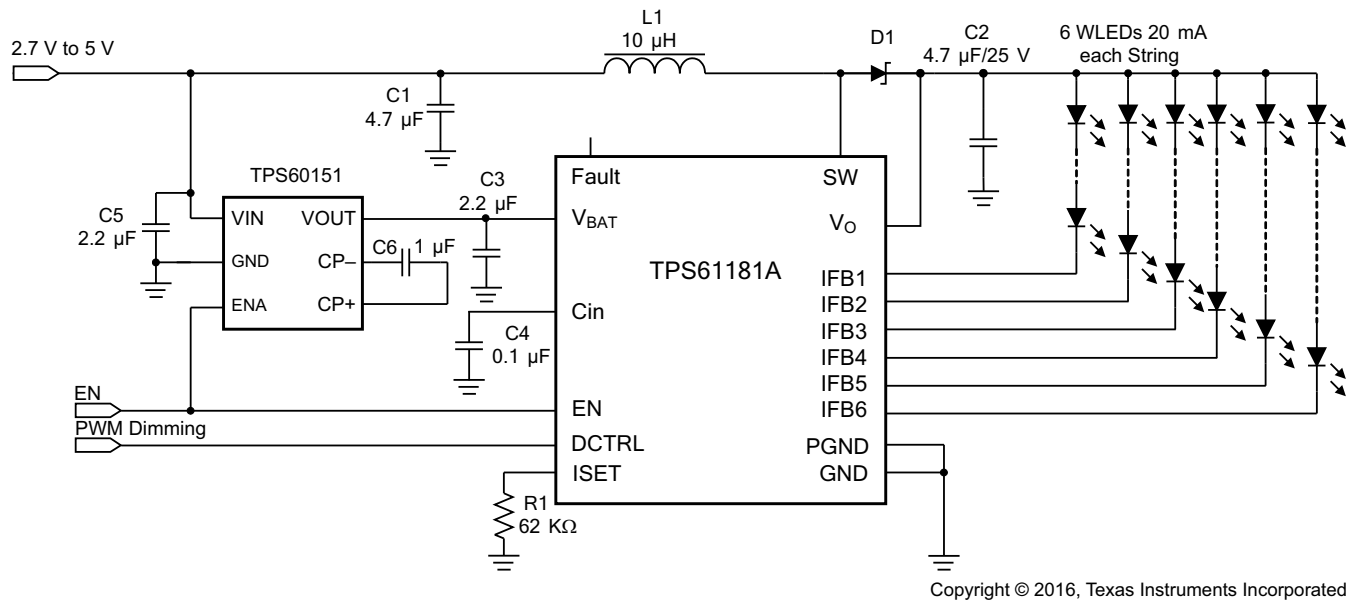

Figure 23. TPS61181A + TPS60151 for One Cell Li-Ion Battery Power Application

10 Power Supply Recommendations

The TPS61181A device requires a  $V_{BAT}$  pin supply from 4.5 V to 24 V.

## 11 Layout

### 11.1 Layout Guidelines

As for all switching power supplies, especially those providing high current and using high switching frequencies, layout is an important design step. If layout is not carefully done, the regulator could show instability as well as EMI problems. Therefore, use wide and short traces for high current paths. The input capacitor, C3 in the typical application circuit, needs not only to be close to the  $V_{BAT}$  pin, but also to the GND pin in order to reduce the input ripple detected by the device. The input capacitor, C1 in Figure 9, must be placed close to the inductor. The SW pin carries high current with fast rising and falling edges. Therefore, keep the connection between the pin to the inductor and Schottky as short and wide as possible. It is also beneficial to have the ground of the output capacitor C2 close to the PGND pin because there is large ground return current flowing between them. When laying out signal ground, TI recommends using short traces separated from power ground traces, connecting these short traces together at a single point, for example on the thermal pad.

Thermal pad must be soldered on to the PCB and connected to the GND pin of the TPS61181A device. Additional thermal via can significantly improve power dissipation of the device.

### 11.2 Layout Example

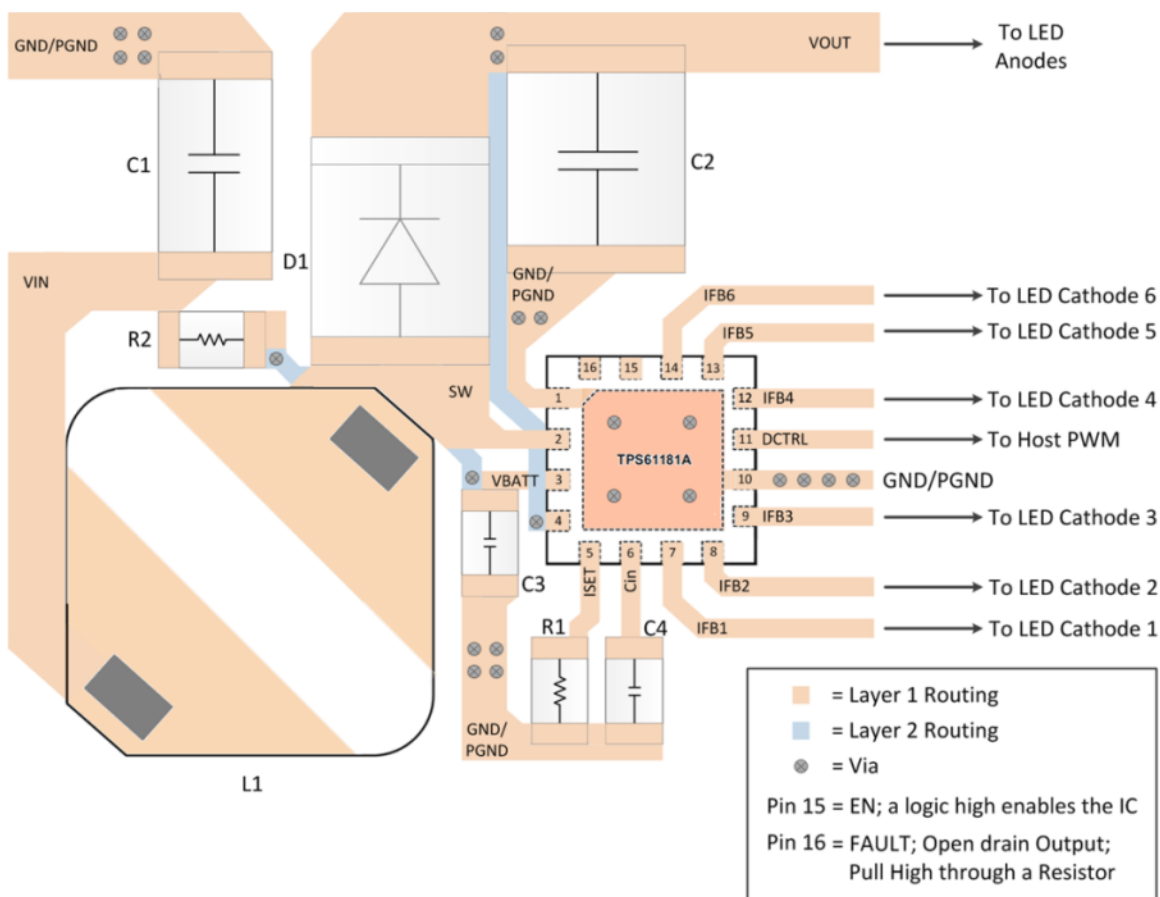

Figure 24. TPS61181A Layout

## 12 Device And Documentation Support

### 12.1 Device Support

#### 12.1.1 Third-Party Products Disclaimer

TI'S PUBLICATION OF INFORMATION REGARDING THIRD-PARTY PRODUCTS OR SERVICES DOES NOT CONSTITUTE AN ENDORSEMENT REGARDING THE SUITABILITY OF SUCH PRODUCTS OR SERVICES OR A WARRANTY, REPRESENTATION OR ENDORSEMENT OF SUCH PRODUCTS OR SERVICES, EITHER ALONE OR IN COMBINATION WITH ANY TI PRODUCT OR SERVICE.

#### 12.2 Receiving Notification of Documentation Updates

To receive notification of documentation updates, navigate to the device product folder on ti.com. In the upper right corner, click on *Alert me* to register and receive a weekly digest of any product information that has changed. For change details, review the revision history included in any revised document.

#### 12.3 Community Resources

The following links connect to TI community resources. Linked contents are provided "AS IS" by the respective contributors. They do not constitute TI specifications and do not necessarily reflect TI's views; see TI's [Terms of Use](#).

**TI E2E™ Online Community** *TI's Engineer-to-Engineer (E2E) Community*. Created to foster collaboration among engineers. At e2e.ti.com, you can ask questions, share knowledge, explore ideas and help solve problems with fellow engineers.

**Design Support** *TI's Design Support* Quickly find helpful E2E forums along with design support tools and contact information for technical support.

#### 12.4 Trademarks

E2E is a trademark of Texas Instruments.  
All other trademarks are the property of their respective owners.

#### 12.5 Electrostatic Discharge Caution



These devices have limited built-in ESD protection. The leads should be shorted together or the device placed in conductive foam during storage or handling to prevent electrostatic damage to the MOS gates.

#### 12.6 Glossary

[SLYZ022](#) — *TI Glossary*.

This glossary lists and explains terms, acronyms, and definitions.

## 13 Mechanical, Packaging, and Orderable Information

The following pages include mechanical, packaging, and orderable information. This information is the most current data available for the designated devices. This data is subject to change without notice and revision of this document. For browser-based versions of this data sheet, refer to the left-hand navigation.

**PACKAGING INFORMATION**

Orderable Device	Status (1)	Package Type	Package Drawing	Pins	Package Qty	Eco Plan (2)	Lead finish/ Ball material (6)	MSL Peak Temp (3)	Op Temp (°C)	Device Marking (4/5)	Samples
TPS61181ARTER	ACTIVE	WQFN	RTE	16	3000	RoHS & Green	NIPDAU	Level-2-260C-1 YEAR	-40 to 85	QWF	<a href="#">Samples</a>
TPS61181ARTET	ACTIVE	WQFN	RTE	16	250	RoHS & Green	NIPDAU	Level-2-260C-1 YEAR	-40 to 85	QWF	<a href="#">Samples</a>

(1) The marketing status values are defined as follows:

**ACTIVE:** Product device recommended for new designs.

**LIFEBUY:** TI has announced that the device will be discontinued, and a lifetime-buy period is in effect.

**NRND:** Not recommended for new designs. Device is in production to support existing customers, but TI does not recommend using this part in a new design.

**PREVIEW:** Device has been announced but is not in production. Samples may or may not be available.

**OBSOLETE:** TI has discontinued the production of the device.

(2) **RoHS:** TI defines "RoHS" to mean semiconductor products that are compliant with the current EU RoHS requirements for all 10 RoHS substances, including the requirement that RoHS substance do not exceed 0.1% by weight in homogeneous materials. Where designed to be soldered at high temperatures, "RoHS" products are suitable for use in specified lead-free processes. TI may reference these types of products as "Pb-Free".

**RoHS Exempt:** TI defines "RoHS Exempt" to mean products that contain lead but are compliant with EU RoHS pursuant to a specific EU RoHS exemption.

**Green:** TI defines "Green" to mean the content of Chlorine (Cl) and Bromine (Br) based flame retardants meet JS709B low halogen requirements of <=1000ppm threshold. Antimony trioxide based flame retardants must also meet the <=1000ppm threshold requirement.

(3) MSL, Peak Temp. - The Moisture Sensitivity Level rating according to the JEDEC industry standard classifications, and peak solder temperature.

(4) There may be additional marking, which relates to the logo, the lot trace code information, or the environmental category on the device.

(5) Multiple Device Markings will be inside parentheses. Only one Device Marking contained in parentheses and separated by a "~" will appear on a device. If a line is indented then it is a continuation of the previous line and the two combined represent the entire Device Marking for that device.

(6) Lead finish/Ball material - Orderable Devices may have multiple material finish options. Finish options are separated by a vertical ruled line. Lead finish/Ball material values may wrap to two lines if the finish value exceeds the maximum column width.

**Important Information and Disclaimer:**The information provided on this page represents TI's knowledge and belief as of the date that it is provided. TI bases its knowledge and belief on information provided by third parties, and makes no representation or warranty as to the accuracy of such information. Efforts are underway to better integrate information from third parties. TI has taken and continues to take reasonable steps to provide representative and accurate information but may not have conducted destructive testing or chemical analysis on incoming materials and chemicals. TI and TI suppliers consider certain information to be proprietary, and thus CAS numbers and other limited information may not be available for release.

In no event shall TI's liability arising out of such information exceed the total purchase price of the TI part(s) at issue in this document sold by TI to Customer on an annual basis.



**TAPE AND REEL INFORMATION**

**QUADRANT ASSIGNMENTS FOR PIN 1 ORIENTATION IN TAPE**

\*All dimensions are nominal

Device	Package Type	Package Drawing	Pins	SPQ	Reel Diameter (mm)	Reel Width W1 (mm)	A0 (mm)	B0 (mm)	K0 (mm)	P1 (mm)	W (mm)	Pin1 Quadrant
TPS61181ARTER	WQFN	RTE	16	3000	330.0	12.4	3.3	3.3	1.1	8.0	12.0	Q2
TPS61181ARTET	WQFN	RTE	16	250	180.0	12.4	3.3	3.3	1.1	8.0	12.0	Q2

**TAPE AND REEL BOX DIMENSIONS**

\*All dimensions are nominal

Device	Package Type	Package Drawing	Pins	SPQ	Length (mm)	Width (mm)	Height (mm)
TPS61181ARTER	WQFN	RTE	16	3000	356.0	356.0	35.0
TPS61181ARTET	WQFN	RTE	16	250	210.0	185.0	35.0

## GENERIC PACKAGE VIEW

**RTE 16**

**WQFN - 0.8 mm max height**

3 x 3, 0.5 mm pitch

PLASTIC QUAD FLATPACK - NO LEAD

This image is a representation of the package family, actual package may vary.  
Refer to the product data sheet for package details.

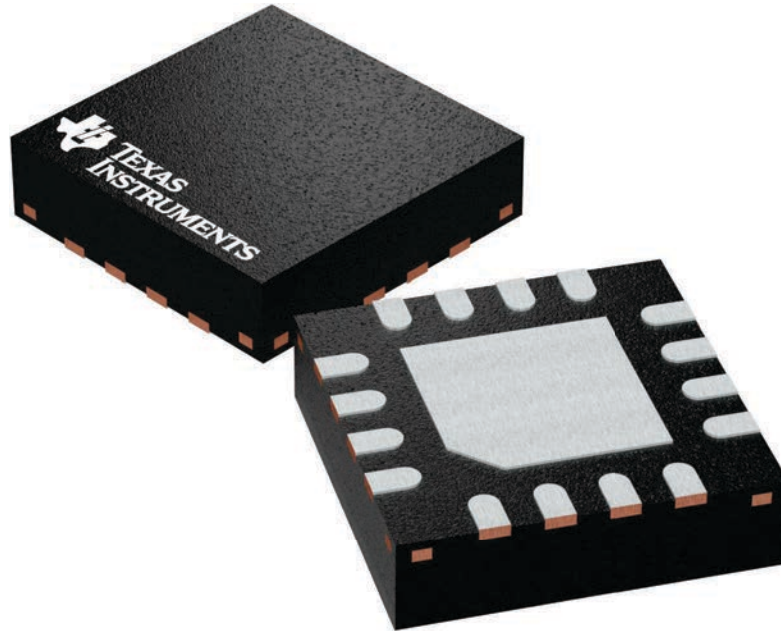

4225944/A

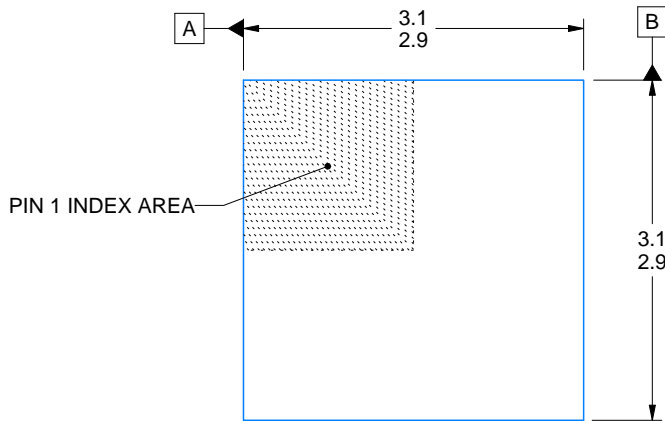

SIDE WALL METAL THICKNESS DIM A	
OPTION 1	OPTION 2
0.1	0.2

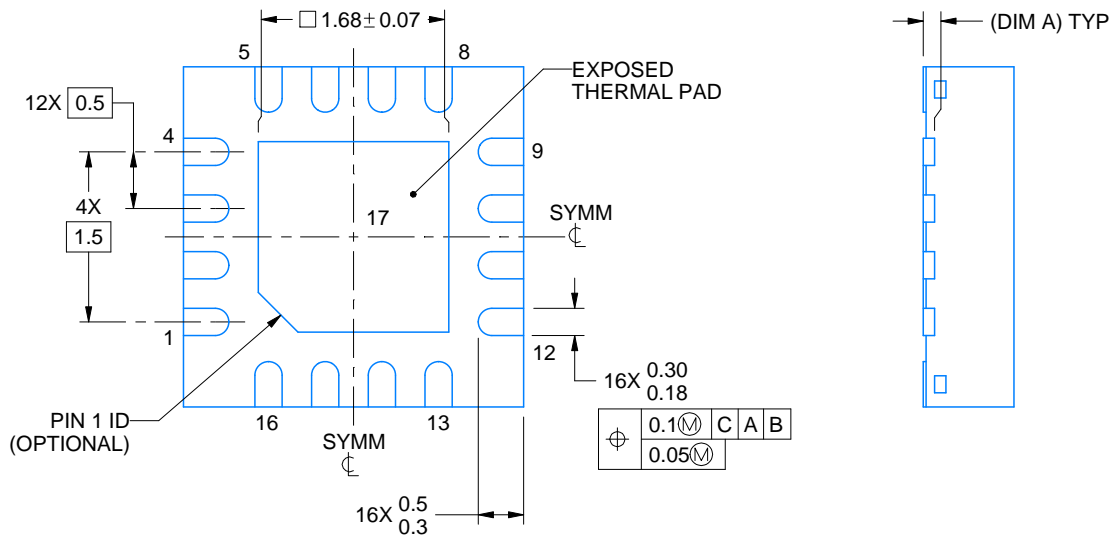
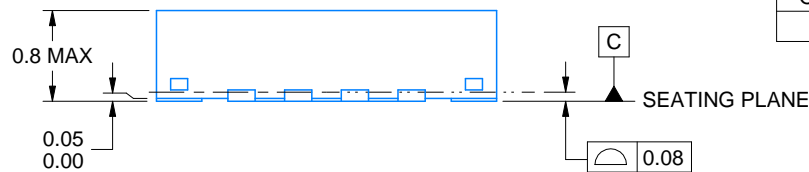

4219117/B 04/2022

NOTES:

1. All linear dimensions are in millimeters. Any dimensions in parenthesis are for reference only. Dimensioning and tolerancing per ASME Y14.5M.
2. This drawing is subject to change without notice.
3. The package thermal pad must be soldered to the printed circuit board for thermal and mechanical performance.

# EXAMPLE BOARD LAYOUT

RTE0016C

WQFN - 0.8 mm max height

PLASTIC QUAD FLATPACK - NO LEAD

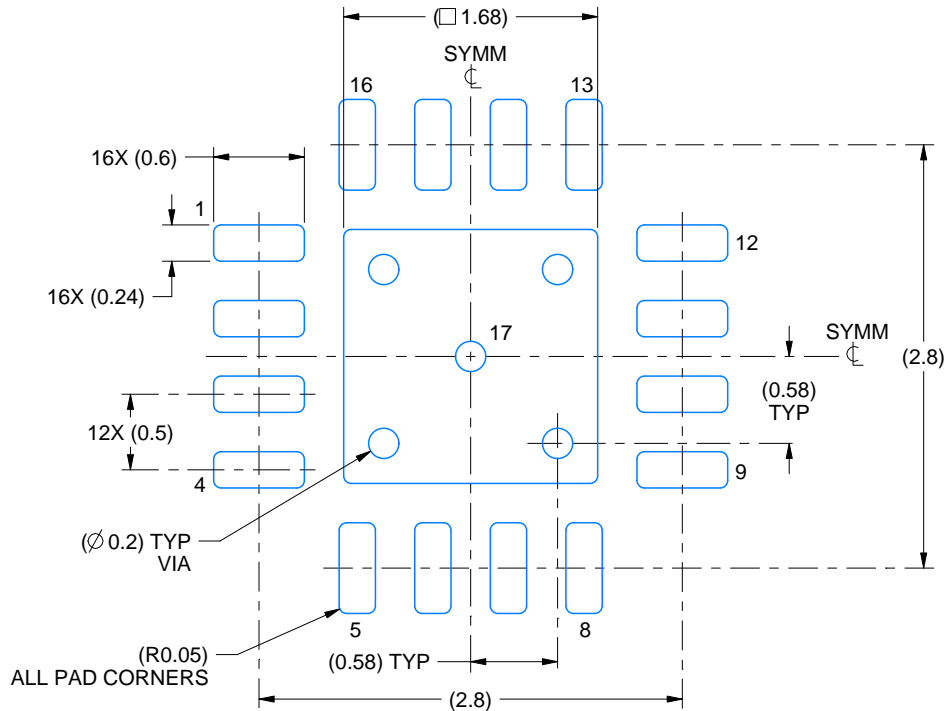

LAND PATTERN EXAMPLE  
EXPOSED METAL SHOWN  
SCALE:20X

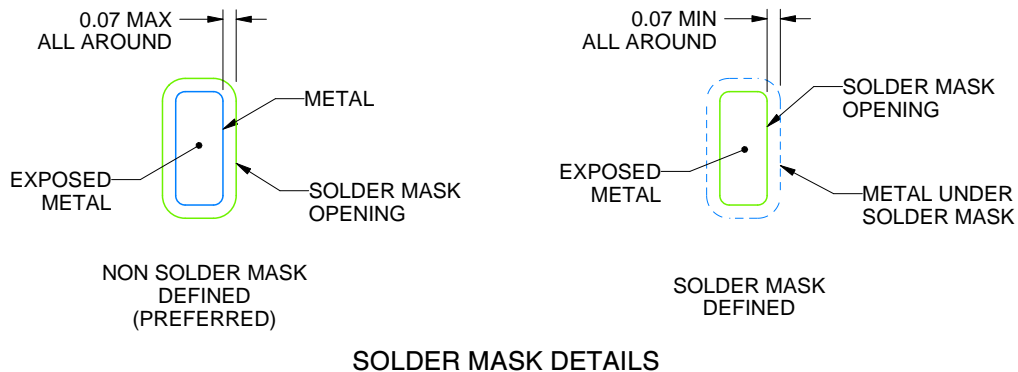

SOLDER MASK DETAILS

4219117/B 04/2022

NOTES: (continued)

- This package is designed to be soldered to a thermal pad on the board. For more information, see Texas Instruments literature number SLUA271 ([www.ti.com/lit/slua271](http://www.ti.com/lit/slua271)).
- Vias are optional depending on application, refer to device data sheet. If any vias are implemented, refer to their locations shown on this view. It is recommended that vias under paste be filled, plugged or tented.

# EXAMPLE STENCIL DESIGN

RTE0016C

WQFN - 0.8 mm max height

PLASTIC QUAD FLATPACK - NO LEAD

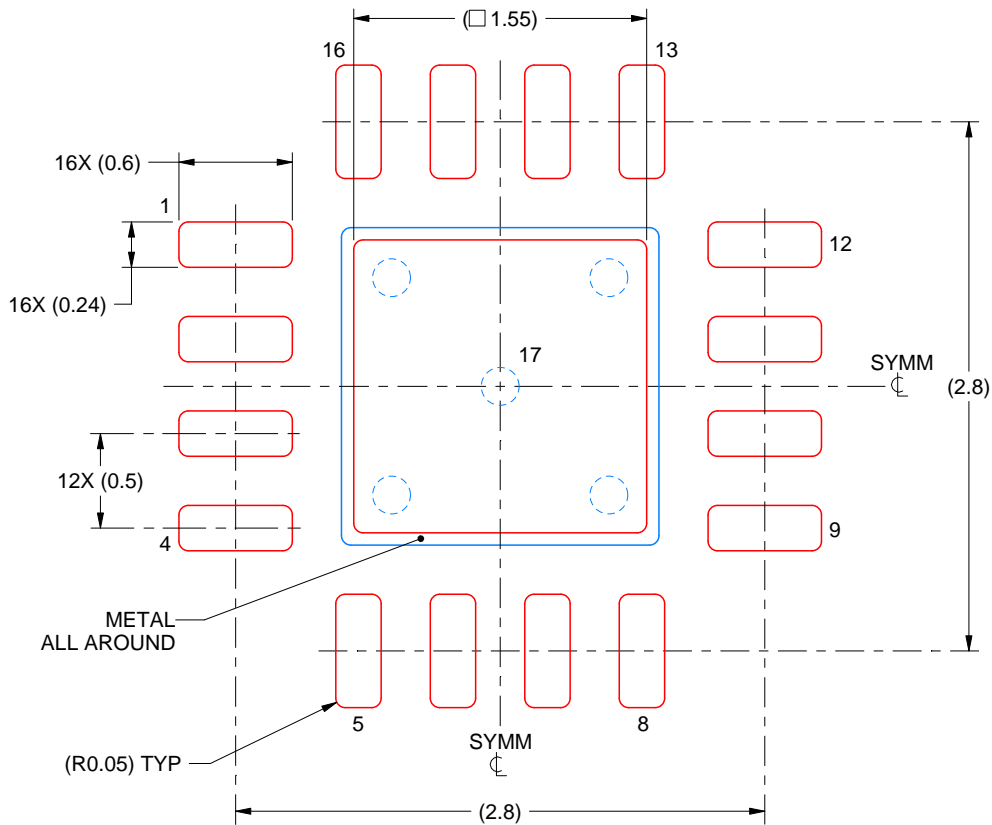

**SOLDER PASTE EXAMPLE**  
BASED ON 0.125 mm THICK STENCIL

EXPOSED PAD 17:  
85% PRINTED SOLDER COVERAGE BY AREA UNDER PACKAGE  
SCALE:25X

4219117/B 04/2022

NOTES: (continued)

6. Laser cutting apertures with trapezoidal walls and rounded corners may offer better paste release. IPC-7525 may have alternate design recommendations.

## IMPORTANT NOTICE AND DISCLAIMER

TI PROVIDES TECHNICAL AND RELIABILITY DATA (INCLUDING DATA SHEETS), DESIGN RESOURCES (INCLUDING REFERENCE DESIGNS), APPLICATION OR OTHER DESIGN ADVICE, WEB TOOLS, SAFETY INFORMATION, AND OTHER RESOURCES "AS IS" AND WITH ALL FAULTS, AND DISCLAIMS ALL WARRANTIES, EXPRESS AND IMPLIED, INCLUDING WITHOUT LIMITATION ANY IMPLIED WARRANTIES OF MERCHANTABILITY, FITNESS FOR A PARTICULAR PURPOSE OR NON-INFRINGEMENT OF THIRD PARTY INTELLECTUAL PROPERTY RIGHTS.

These resources are intended for skilled developers designing with TI products. You are solely responsible for (1) selecting the appropriate TI products for your application, (2) designing, validating and testing your application, and (3) ensuring your application meets applicable standards, and any other safety, security, regulatory or other requirements.

These resources are subject to change without notice. TI grants you permission to use these resources only for development of an application that uses the TI products described in the resource. Other reproduction and display of these resources is prohibited. No license is granted to any other TI intellectual property right or to any third party intellectual property right. TI disclaims responsibility for, and you will fully indemnify TI and its representatives against, any claims, damages, costs, losses, and liabilities arising out of your use of these resources.

TI's products are provided subject to [TI's Terms of Sale](#) or other applicable terms available either on [ti.com](https://www.ti.com) or provided in conjunction with such TI products. TI's provision of these resources does not expand or otherwise alter TI's applicable warranties or warranty disclaimers for TI products.

TI objects to and rejects any additional or different terms you may have proposed.

Mailing Address: Texas Instruments, Post Office Box 655303, Dallas, Texas 75265  
Copyright © 2023, Texas Instruments Incorporated

## Looking for pricing, stock, or lifecycle information?

Click below to explore more details on WIN SOURCE:

 [View TPS61181ARTER](#) on WIN SOURCE

 [Texas Instruments](#) Information

## Optimize Your Supply Chain with WIN SOURCE Solutions

-  Global Sourcing Solution
-  Obsolete Management
-  Cost Control Management
-  Shortage Management
-  Alternative Solution
-  Excess Inventory Management