



**THE DATASHEET OF  
TPS61165DBVR**



## TPS61165 High-Brightness, White LED Driver in WSON and SOT-23 Packages

### 1 Features

- 3-V to 18-V Input voltage range
- 38-V Open LED protection
- 200-mV Reference voltage with 2% accuracy
- 1.2-A Switch FET with 1.2-MHz switching frequency
- Flexible one-wire digital and PWM brightness control
- Built-in soft start
- Up to 90% efficiency
- 2-mm × 2-mm × 0.8-mm 6-Pin WSON package with thermal pad, and SOT-23 package

### 2 Applications

- High-brightness LED lighting
- White LED backlighting for media form factor display
- Handheld data terminals (EPOS)
- Thermostat display
- Human machine interface (HMI)
- Video surveillance camera
- Exit signs
- HMI and control panels
- Industrial PCs
- IR LED driver
- Refrigerator
- Ovens

### 3 Description

With a 40-V rated integrated switch FET, the TPS61165 device is a boost converter that drives LEDs in series. The boost converter runs at a 1.2-MHz fixed switching frequency with 1.2-A switch current limit, allowing the use of a high-brightness LED in general lighting.

The default white LED current is set with the external sensor resistor  $R_{set}$ , and the feedback voltage is regulated to 200 mV, as shown in the *Typical Application* drawing below. During the operation, the LED current can be controlled using the one-wire digital interface (EasyScale™ protocol) through the CTRL pin. Alternatively, a pulse-width-modulation (PWM) signal can be applied to the CTRL pin through which the duty cycle determines the feedback reference voltage. In either digital or PWM mode, the TPS61165 device does not burst the LED current; therefore, it does not generate audible noises on the output capacitor. For maximum protection, the device features integrated open-LED protection that disables the TPS61165 device to prevent the output from exceeding its absolute maximum voltage ratings during open LED conditions.

#### Device Information<sup>(1)</sup>

PART NUMBER	PACKAGE	BODY SIZE (NOM)
TPS61165	SOT-23 (6)	2.90 mm × 1.60 mm
	WSON (6)	2.00 mm × 2.00 mm

(1) For all available packages, see the orderable addendum at the end of the data sheet.

#### Typical Application

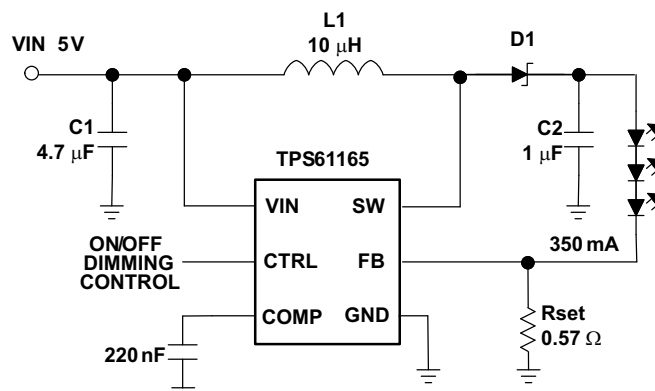

L1: TOKO #A915\_Y-100M  
 C1: Murata GRM188R61A475K  
 C2: Murata GRM188R61E105K  
 D1: ONsemi MBR0540T1  
 LED: OSRAM LW-W5SM

Copyright © 2016, Texas Instruments Incorporated



## Table of Contents

<b>1 Features</b> .....	<b>1</b>	<b>9 Application and Implementation</b> .....	<b>10</b>
<b>2 Applications</b> .....	<b>1</b>	9.1 Application Information.....	10
<b>3 Description</b> .....	<b>1</b>	9.2 Typical Applications .....	12
<b>4 Revision History</b> .....	<b>2</b>	9.3 Do's and Don'ts.....	20
<b>5 Device Options</b> .....	<b>3</b>	<b>10 Power Supply Recommendations</b> .....	<b>21</b>
<b>6 Pin Configuration and Functions</b> .....	<b>3</b>	<b>11 Layout</b> .....	<b>21</b>
<b>7 Specifications</b> .....	<b>4</b>	11.1 Layout Guidelines .....	21
7.1 Absolute Maximum Ratings .....	4	11.2 Layout Example .....	21
7.2 Recommended Operating Conditions .....	4	11.3 Thermal Considerations .....	22
7.3 Thermal Information .....	4	<b>12 Device and Documentation Support</b> .....	<b>23</b>
7.4 Electrical Characteristics.....	5	12.1 Device Support.....	23
7.5 Timing Requirements .....	6	12.2 Documentation Support .....	23
7.6 Typical Characteristics .....	6	12.3 Community Resources.....	23
<b>8 Detailed Description</b> .....	<b>8</b>	12.4 Trademarks .....	23
8.1 Overview .....	8	12.5 Electrostatic Discharge Caution.....	23
8.2 Functional Block Diagram .....	8	12.6 Glossary .....	23
8.3 Feature Description.....	9	<b>13 Mechanical, Packaging, and Orderable Information</b> .....	<b>23</b>
8.4 Device Functional Modes.....	9		

## 4 Revision History

Changes from Revision D (April 2016) to Revision E	Page
• Added clear description to separate Easyscale Mode and PWM mode .....	12
• Changed 5 khz to 6.5 khz in first paragraph after <a href="#">Figure 10</a> .....	14

Changes from Revision C (January 2015) to Revision D	Page
• Added new items to <i>Applications</i> list .....	1

Changes from Revision B (July 2011) to Revision C	Page
• Added <i>Pin Configuration and Functions</i> section, <i>Feature Description</i> section, <i>Device Functional Modes</i> , <i>Application and Implementation</i> section, <i>Power Supply Recommendations</i> section, <i>Layout</i> section, <i>Device and Documentation Support</i> section, and <i>Mechanical, Packaging, and Orderable Information</i> section .....	1

Changes from Revision A (May 2010) to Revision B	Page
• Replaced the Dissipations Ratings Table with the Thermal Information Table.....	4
• Changed <a href="#">Figure 10</a> .....	14
• Changed <a href="#">Additional Application Circuits</a> and added text "For Assistance..." .....	18

Changes from Original (November 2007) to Revision A	Page
• Added "and SOT-23 Package" to the Title, the last Features item, and the last paragraph of the Description.....	1
• Added 6-pin SOT-23 pinout to the Device Information section .....	3
• Added the DBV package to the Ordering Information table .....	3
• Changed the Dissipation Rating Table to include the DBV package .....	4
• Changed two values in the last paragraph of the MAXIMUM OUTPUT CURRENT section - From: 65 mA To: 110 mA in typical condition, and From: 85 mA To: 150 mA in typical condition .....	10

## 5 Device Options

T <sub>A</sub>	OPEN LED PROTECTION	PACKAGE <sup>(1)</sup>	PACKAGE MARKING
–40°C to 85°C	38 V (typical)	TPS61165DRV	CCQ
		TPS61165DBV	DAK

- (1) The DRV package is available in tape and reel. Add R suffix (TPS61165DRVR) to order quantities of 3000 parts per reel or add T suffix (TPS61165DRVT) to order 250 parts per reel.

## 6 Pin Configuration and Functions

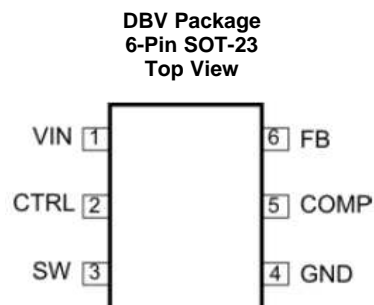
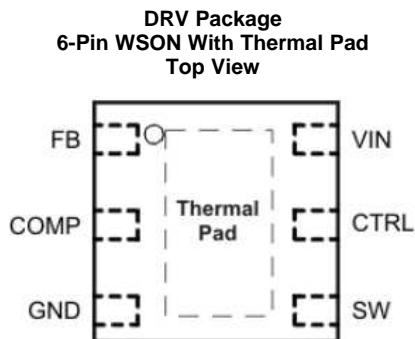

### Pin Functions

NAME	PIN		TYPE	DESCRIPTION
	WSON NO.	SOT-23 NO.		
CTRL	5	2	I	Control pin of the boost converter. It is a multifunctional pin which can be used for enable control, PWM and digital dimming.
COMP	2	5	O	Output of the transconductance error amplifier. Connect an external capacitor to this pin to compensate the converter.
FB	1	6	I	Feedback pin for current. Connect the sense resistor from FB to GND.
GND	3	4	O	Ground
SW	4	3	I	This is the switching node of the device. Connect the switched side of the inductor to SW. This pin is also used to sense the output voltage for open LED protection.
VIN	6	1	I	The input supply pin for the IC. Connect VIN to a supply voltage between 3 V and 18 V.
Thermal Pad	—	—	—	The thermal pad must be soldered to the analog ground plane. If possible, use thermal via to connect to ground plane for ideal power dissipation.

## 7 Specifications

### 7.1 Absolute Maximum Ratings

over operating free-air temperature range (unless otherwise noted)<sup>(1)</sup>

		MIN	MAX	UNIT
V <sub>IN</sub>	Supply voltages on VIN <sup>(2)</sup>	-0.3	20	V
	Voltages on CTRL <sup>(2)</sup>	-0.3	20	V
	Voltage on FB and COMP <sup>(2)</sup>	-0.3	3	V
	Voltage on SW <sup>(2)</sup>	-0.3	40	V
P <sub>D</sub>	Continuous power dissipation	See <a href="#">Thermal Information</a>		
T <sub>J</sub>	Operating junction temperature	-40	150	°C
T <sub>stg</sub>	Storage temperature	-65	150	°C

- (1) Stresses beyond those listed under *Absolute Maximum Ratings* may cause permanent damage to the device. These are stress ratings only, and functional operation of the device at these or any other conditions beyond those indicated under *Recommended Operating Conditions* is not implied. Exposure to absolute-maximum-rated conditions for extended periods may affect device reliability.
- (2) All voltage values are with respect to network ground pin.

### 7.2 Recommended Operating Conditions

		MIN	TYP	MAX	UNIT
V <sub>I</sub>	Input voltage range, VIN	3		18	V
V <sub>O</sub>	Output voltage range	V <sub>IN</sub>		38	V
L	Inductor <sup>(1)</sup>	10		22	μH
f <sub>dim</sub>	PWM dimming frequency	5		100	kHz
C <sub>IN</sub>	Input capacitor	1			μF
C <sub>O</sub>	Output capacitor	1		10	μF
T <sub>A</sub>	Operating ambient temperature	-40		85	°C
T <sub>J</sub>	Operating junction temperature	-40		125	°C

- (1) These values are recommended values that have been successfully tested in several applications. Other values may be acceptable in other applications but should be fully tested by the user.

### 7.3 Thermal Information

THERMAL METRIC <sup>(1)(2)</sup>		TPS61165		UNIT
		DRV (WSON)	DBV (SOT-23)	
		6 PINS	6 PINS	
R <sub>θJA</sub>	Junction-to-ambient thermal resistance	80.7	210.1	°C/W
R <sub>θJC(top)</sub>	Junction-to-case(top) thermal resistance	55.4	46.8	°C/W
R <sub>θJB</sub>	Junction-to-board thermal resistance	140.2	56.7	°C/W
ψ <sub>JT</sub>	Junction-to-top characterization parameter	0.3	0.5	°C/W
ψ <sub>JB</sub>	Junction-to-board characterization parameter	36.5	50.2	°C/W
R <sub>θJC(bottom)</sub>	Junction-to-case(bottom) thermal resistance	0.9	—	°C/W

- (1) For more information about traditional and new thermal metrics, see the *Semiconductor and IC Package Thermal Metrics* application report (SPRA953).
- (2) For thermal estimates of this device based on PCB copper area, see the [TI PCB Thermal Calculator](#).

## 7.4 Electrical Characteristics

 $V_{IN} = 3.6\text{ V}$ ,  $CTRL = V_{IN}$ ,  $T_A = -40^\circ\text{C}$  to  $+85^\circ\text{C}$ , typical values are at  $T_A = 25^\circ\text{C}$  (unless otherwise noted)

PARAMETER		TEST CONDITIONS	MIN	TYP	MAX	UNIT
<b>SUPPLY CURRENT</b>						
$V_I$	Input voltage range, $V_{IN}$		3		18	V
$I_Q$	Operating quiescent current into VIN	Device PWM switching no load			2.3	mA
$I_{SD}$	Shutdown current	$CTRL=GND$ , $V_{IN} = 4.2\text{ V}$			1	$\mu\text{A}$
UVLO	Undervoltage lockout threshold	$V_{IN}$ falling		2.2	2.5	V
$V_{hys}$	Undervoltage lockout hysteresis			70		mV
<b>ENABLE AND REFERENCE CONTROL</b>						
$V_{(CTRLh)}$	CTRL logic high voltage	$V_{IN} = 3\text{ V}$ to $18\text{ V}$	1.2			V
$V_{(CTRLl)}$	CTRL logic low voltage	$V_{IN} = 3\text{ V}$ to $18\text{ V}$			0.4	V
$R_{(CTRL)}$	CTRL pull down resistor		400	800	1600	k $\Omega$
$t_{off}$	CTRL pulse width to shutdown	CTRL high to low	2.5			ms
$t_{es\_det}$	Easy Scale detection time <sup>(1)</sup>	CTRL pin low	260			$\mu\text{s}$
$t_{es\_delay}$	Easy Scale detection delay		100			$\mu\text{s}$
$t_{es\_win}$	Easy Scale detection window time	Measured from CTRL high	1			ms
<b>VOLTAGE AND CURRENT CONTROL</b>						
$V_{REF}$	Voltage feedback regulation voltage		196	200	204	mV
$V_{(REF\_PWM)}$	Voltage feedback regulation voltage under brightness control	$V_{FB} = 50\text{ mV}$	47	50	53	mV
		$V_{FB} = 20\text{ mV}$	17	20	23	
$I_{FB}$	Voltage feedback input bias current	$V_{FB} = 200\text{ mV}$			2	$\mu\text{A}$
$f_S$	Oscillator frequency		1.0	1.2	1.5	MHz
$D_{max}$	Maximum duty cycle	$V_{FB} = 100\text{ mV}$	90%	93%		
$t_{min\_on}$	Minimum on pulse width			40		ns
$I_{sink}$	Comp pin sink current			100		$\mu\text{A}$
$I_{source}$	Comp pin source current			100		$\mu\text{A}$
$G_{ea}$	Error amplifier transconductance		240	320	400	umho
$R_{ea}$	Error amplifier output resistance			6		M $\Omega$
$f_{ea}$	Error amplifier crossover frequency	5 pF connected to COMP		500		kHz
<b>POWER SWITCH</b>						
$R_{DS(ON)}$	N-channel MOSFET on-resistance	$V_{IN} = 3.6\text{ V}$		0.3	0.6	$\Omega$
		$V_{IN} = 3.0\text{ V}$			0.7	
$I_{LN\_NFET}$	N-channel leakage current	$V_{SW} = 35\text{ V}$ , $T_A = 25^\circ\text{C}$			1	$\mu\text{A}$
<b>OC and OLP</b>						
$I_{LIM}$	N-Channel MOSFET current limit	$D = D_{max}$	0.96	1.2	1.44	A
$I_{LIM\_Start}$	Start up current limit	$D = D_{max}$		0.7		A
$t_{Half\_LIM}$	Time step for half current limit			5		ms
$V_{ovp}$	Open LED protection threshold	Measured on the SW pin	37	38	39	V
$V_{(FB\_OVP)}$	Open LED protection threshold on FB	Measured on the FB pin, percentage of $V_{ref}$ , $V_{ref} = 200\text{ mV}$ and $20\text{ mV}$		50%		
$t_{REF}$	$V_{REF}$ filter time constant			180		$\mu\text{s}$
$t_{step}$	$V_{REF}$ ramp up time	Each step, Measured as number of cycles of the 1.2-MHz clock		213		$\mu\text{s}$
<b>THERMAL SHUTDOWN</b>						
$T_{shutdown}$	Thermal shutdown threshold			160		$^\circ\text{C}$
$T_{hysteresis}$	Thermal shutdown threshold hysteresis			15		$^\circ\text{C}$

(1) To select EasyScale mode, the CTRL pin has to be low for more than  $t_{es\_det}$  during  $t_{es\_win}$ .

## 7.5 Timing Requirements

			MIN	NOM	MAX	UNIT
<b>EasyScale TIMING</b>						
$t_{start}$	Start time of program stream		2			$\mu\text{s}$
$t_{EOS}$	End time of program stream		2		360	$\mu\text{s}$
$t_{H\_LB}$	High time low bit	Logic 0	2		180	$\mu\text{s}$
$t_{L\_LB}$	Low time low bit	Logic 0	$2 \times t_{H\_LB}$		360	$\mu\text{s}$
$t_{H\_HB}$	High time high bit	Logic 1	$2 \times t_{L\_HB}$		360	$\mu\text{s}$
$t_{L\_HB}$	Low time high bit	Logic 1	2		180	$\mu\text{s}$
$V_{ACKNL}$	Acknowledge output voltage low	Open drain, $R_{pullup} = 15 \text{ k}\Omega$ to $V_{IN}$			0.4	V
$t_{valACKN}$	Acknowledge valid time	See <sup>(1)</sup>			2	$\mu\text{s}$
$t_{ACKN}$	Duration of acknowledge condition	See <sup>(1)</sup>			512	$\mu\text{s}$

(1) Acknowledge condition active 0, this condition is only applied in case the RFA bit is set. Open-drain output, line must be pulled high by the host with resistor load.

## 7.6 Typical Characteristics

Table 1. Table of Graphs

		FIGURE
Efficiency	3 LEDs ( $V_{OUT} = 12 \text{ V}$ ); $V_{IN} = 3, 5, 8.5 \text{ V}$ ; $L = 10 \mu\text{H}$	<a href="#">Figure 1</a>
Efficiency	6 LEDs ( $V_{OUT} = 24 \text{ V}$ ); $V_{IN} = 5, 8.5, 12 \text{ V}$ ; $L = 10 \mu\text{H}$	<a href="#">Figure 2</a>
Current limit	$T_A = 25^\circ\text{C}$	<a href="#">Figure 3</a>
Current limit		<a href="#">Figure 4</a>
Easyscale step		<a href="#">Figure 13</a>
PWM dimming linearity	$V_{IN} = 3.6 \text{ V}$ ; PWM Freq = 10 kHz and 32 kHz	<a href="#">Figure 14</a>
Output ripple at PWM dimming	3 LEDs; $V_{IN} = 5 \text{ V}$ ; $I_{LOAD} = 350 \text{ mA}$ ; PWM = 32 kHz	<a href="#">Figure 15</a>
Switching waveform	3 LEDs; $V_{IN} = 5 \text{ V}$ ; $I_{LOAD} = 350 \text{ mA}$ ; $L = 10 \mu\text{H}$	<a href="#">Figure 5</a>
Start-up	3 LEDs; $V_{IN} = 5 \text{ V}$ ; $I_{LOAD} = 350 \text{ mA}$ ; $L = 10 \mu\text{H}$	<a href="#">Figure 6</a>
Open LED protection	8 LEDs; $V_{IN} = 3.6 \text{ V}$ ; $I_{LOAD} = 20 \text{ mA}$	<a href="#">Figure 7</a>

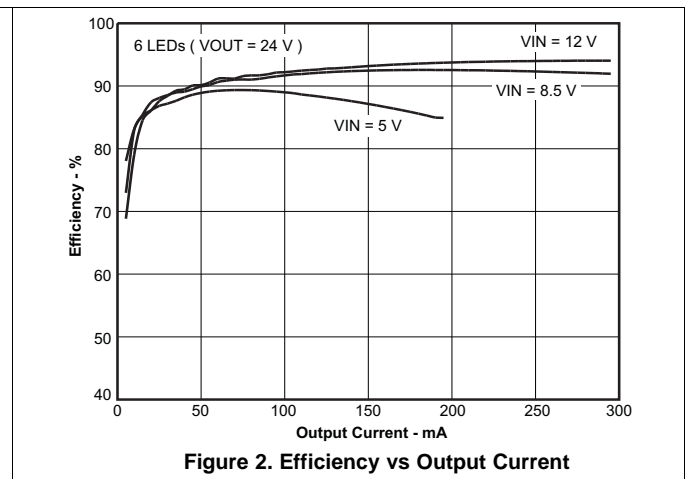
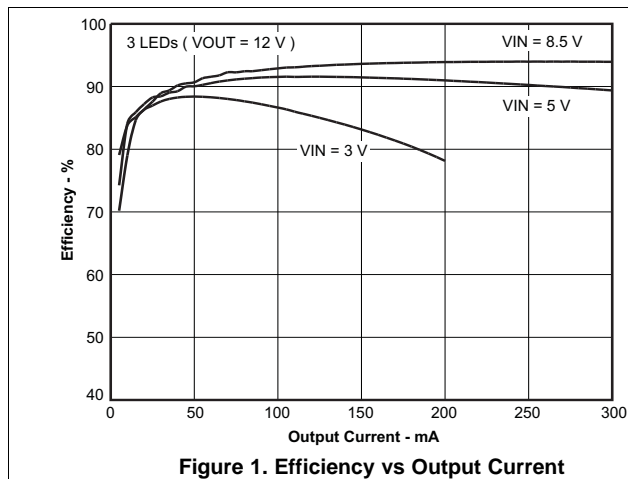

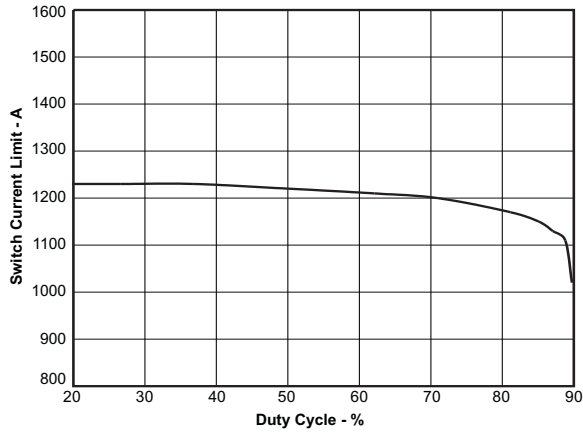

Figure 3. Switch Current Limit vs Duty Cycle

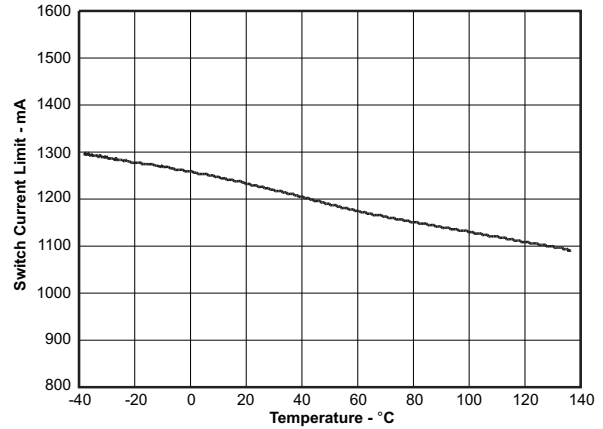

Figure 4. Switch Current Limit vs Temperature

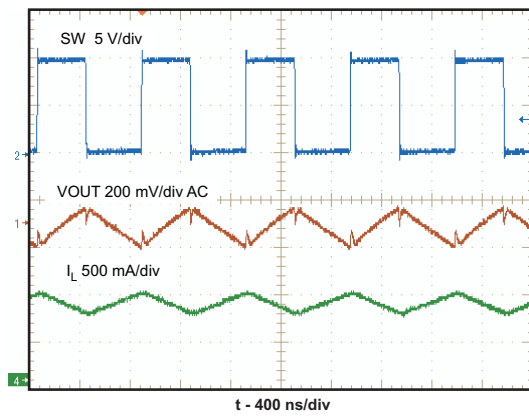

Figure 5. Switching Waveform

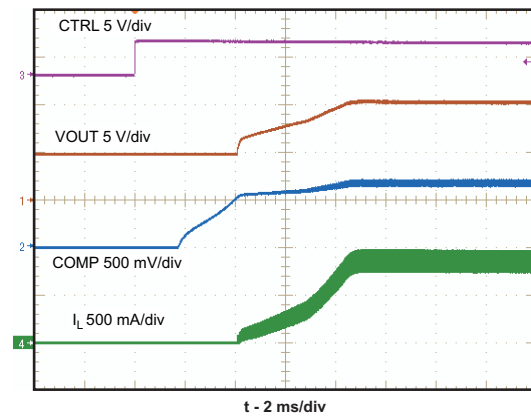

Figure 6. Start-Up

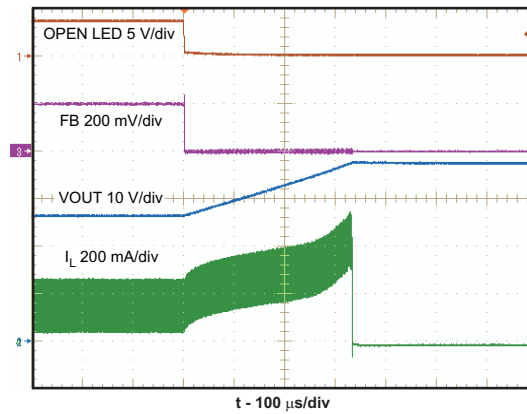

Figure 7. Open LED Protection

## 8 Detailed Description

### 8.1 Overview

The TPS61165 is a high-efficiency, high-output-voltage boost converter in small package size. The device is ideal for driving white LEDs in series. The serial LED connection provides even illumination by sourcing the same output current through all LEDs, eliminating the need for expensive factory calibration. The device integrates 40-V/1.2-A switch FET and operates in pulse width modulation (PWM) with 1.2-MHz fixed switching frequency. (For operation see the [Functional Block Diagram](#).) The duty cycle of the converter is set by the error amplifier output and the current signal applied to the PWM control comparator. The control architecture is based on traditional current-mode control; therefore, slope compensation is added to the current signal to allow stable operation for duty cycles larger than 40%. The feedback loop regulates the FB pin to a low reference voltage (200 mV typical), reducing the power dissipation in the current sense resistor.

### 8.2 Functional Block Diagram

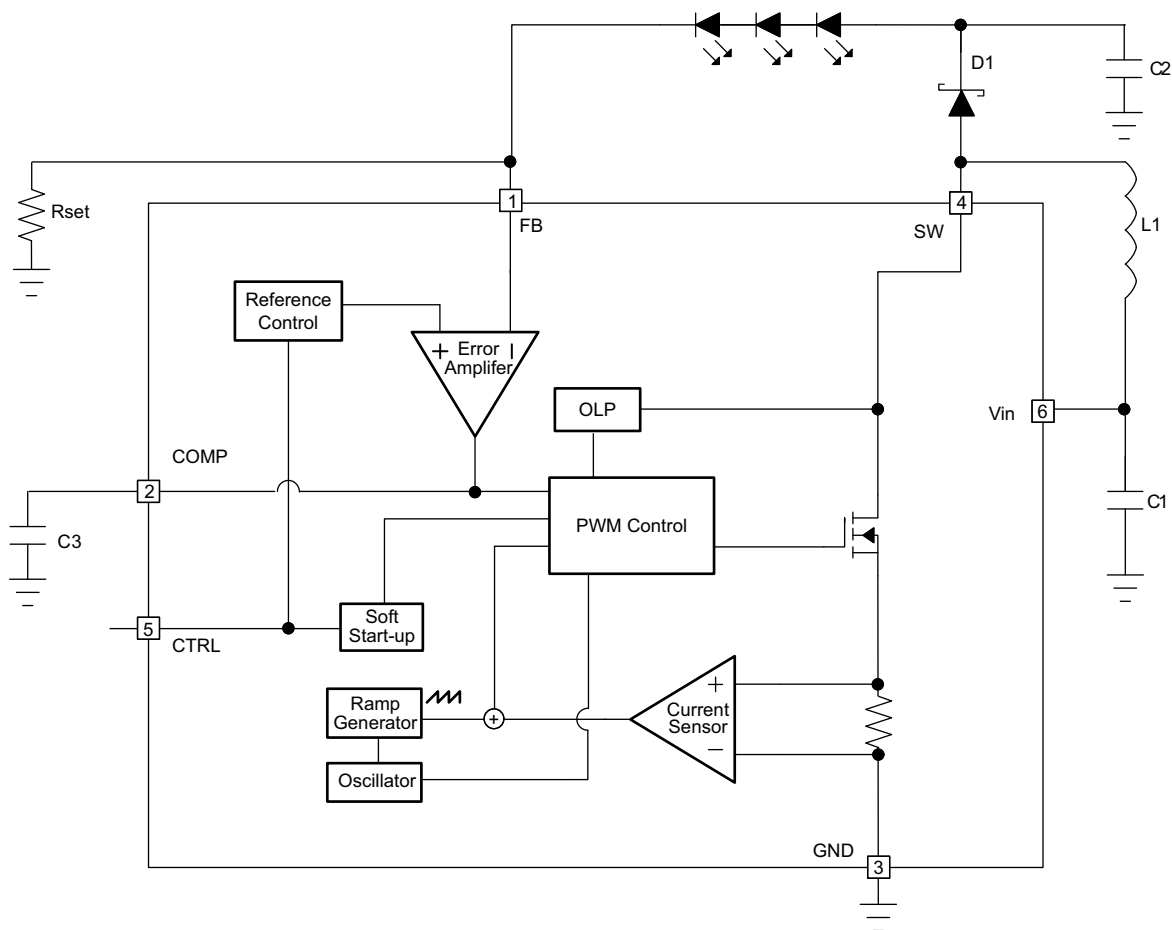

Copyright © 2016, Texas Instruments Incorporated

## 8.3 Feature Description

### 8.3.1 Soft Start-Up

Soft-start circuitry is integrated into the device to avoid a high inrush current during start-up. After the device is enabled, the voltage at FB pin ramps up to the reference voltage in 32 steps — each step takes 213  $\mu$ s. This ensures that the output voltage rises slowly to reduce the input current. Additionally, for the first 5 msec after the COMP voltage ramps, the current limit of the switch is set to half of the normal current limit specification. During this period, the input current is kept below 700 mA (typical). These two features ensure smooth start-up and minimize the inrush current (see [Figure 6](#)).

### 8.3.2 Open LED Protection

Open LED protection circuitry prevents device damage as the result of white LED disconnection. The TPS61165 monitors the voltage at the SW pin and FB pin during each switching cycle. The circuitry turns off the switch FET and shuts down the device when both of the following conditions persist for 8 switching clock cycles: (1) the SW voltage exceeds the  $V_{OVP}$  threshold, and (2) the FB voltage is less than half of regulation voltage. As a result, the output voltage falls to the level of the input supply. The device remains in shutdown mode until it is enabled by toggling the CTRL pin. The product of the number of external series LEDs and the maximum forward voltage of each LED plus the 200-mV reference voltage does not exceed the 38-V minimum OVP threshold ( $N_{LEDs} \times V_{LED(MAX)} + 200 \text{ mV} \leq 38 \text{ V}$ ).

### 8.3.3 Undervoltage Lockout

An undervoltage lockout prevents operation of the device at input voltages below typical 2.2 V. When the input voltage is below the undervoltage threshold, the device is shutdown and the internal switch FET is turned off. If the input voltage rises by undervoltage lockout hysteresis, the device restarts.

### 8.3.4 Thermal Shutdown

An internal thermal shutdown turns off the device when the typical junction temperature of 160°C is exceeded. The device is released from shutdown automatically when the junction temperature decreases by 15°C.

## 8.4 Device Functional Modes

### 8.4.1 Shutdown

The TPS61165 device enters shutdown mode when the CTRL voltage is logic low for more than 2.5 ms. During shutdown, the input supply current for the device is less than 1  $\mu$ A (maximum). Although the internal FET does not switch in shutdown, there is still a dc current path between the input and the LEDs through the inductor and Schottky diode. The minimum forward voltage of the LED array must exceed the maximum input voltage to ensure that the LEDs remain off in shutdown.

## 9 Application and Implementation

### NOTE

Information in the following applications sections is not part of the TI component specification, and TI does not warrant its accuracy or completeness. TI's customers are responsible for determining suitability of components for their purposes. Customers should validate and test their design implementation to confirm system functionality.

### 9.1 Application Information

#### 9.1.1 Maximum Output Current

The overcurrent limit in a boost converter limits the maximum input current and thus maximum input power for a given input voltage. Maximum output power is less than maximum input power due to power conversion losses. Therefore, the current limit setting, input voltage, output voltage and efficiency can all change maximum current output. The current limit clamps the peak inductor current; therefore, the ripple has to be subtracted to derive maximum dc current. The ripple current is a function of switching frequency, inductor value and duty cycle. The following equations take into account of all the above factors for maximum output current calculation.

$$I_p = \frac{1}{\left[ L \times F_s \times \left( \frac{1}{V_{out} + V_f - V_{in}} + \frac{1}{V_{in}} \right) \right]}$$

where

- $I_p$  = inductor peak to peak ripple
- $L$  = inductor value
- $V_f$  = Schottky diode forward voltage
- $F_s$  = switching frequency
- $V_{out}$  = output voltage of the boost converter. It is equal to the sum of VFB and the voltage drop across LEDs.

$$I_{out\_max} = \frac{V_{in} \times (I_{lim} - I_p / 2) \times \eta}{V_{out}}$$

where

- $I_{out\_max}$  = Maximum output current of the boost converter
- $I_{lim}$  = overcurrent limit
- $\eta$  = efficiency

For instance, when  $V_{IN}$  is 3 V, 8 LEDs output equivalent to  $V_{OUT}$  of 26 V, the inductor is 22  $\mu$ H, the Schottky forward voltage is 0.2 V, the maximum output current is then 110 mA in typical condition. When  $V_{IN}$  is 5 V, 10 LEDs output equivalent to  $V_{OUT}$  of 32 V, the inductor is 22  $\mu$ H, the Schottky forward voltage is 0.2 V, the maximum output current is 150 mA in typical condition.

#### 9.1.2 Inductor Selection

Selection of the inductor affects steady state operation as well as transient behavior and loop stability. These factors make it the most important component in power regulator design. There are three important inductor specifications, inductor value, DC resistance and saturation current. Considering inductor value alone is not enough.

The inductor value determines the inductor ripple current. Choose an inductor that can handle the necessary peak current without saturating, according to half of the peak-to-peak ripple current given by [Equation 1](#), pause the inductor DC current given by:

$$I_{in\_DC} = \frac{V_{out} \times I_{out}}{V_{in} \times \eta}$$

## Application Information (continued)

Inductor values can have  $\pm 20\%$  tolerance with no current bias. When the inductor current approaches saturation level, its inductance can decrease 20% to 35% from the 0A value depending on how the inductor vendor defines saturation current. Using an inductor with a smaller inductance value forces discontinuous PWM when the inductor current ramps down to zero before the end of each switching cycle. This reduces the maximum output current of the boost convert, causes large input voltage ripple, and reduces efficiency. Large inductance value provides much more output current and higher conversion efficiency. For these reasons, a 10- $\mu\text{H}$  to 22- $\mu\text{H}$  inductor value range is recommended. A 22- $\mu\text{H}$  inductor optimized the efficiency for most application while maintaining low inductor peak to peak ripple. [Table 2](#) lists the recommended inductor for the TPS61165. When recommending inductor value, the factory has considered  $-40\%$  and  $20\%$  tolerance from its nominal value.

TPS61165 has built-in slope compensation to avoid subharmonic oscillation associated with current mode control. If the inductor value is lower than 10  $\mu\text{H}$ , the slope compensation may not be adequate, and the loop can be unstable. Therefore, customers need to verify the inductor in their application if it is different from the recommended values.

**Table 2. Recommended Inductors for TPS61165**

PART NUMBER	L ( $\mu\text{H}$ )	DCR MAX (m $\Omega$ )	SATURATION CURRENT (A)	SIZE (L x W x H mm)	VENDOR
A915_Y-100M	10	90	1.3	5.2 x 5.2 x 3.0	TOKO
VLCF5020T-100M1R1-1	10	237	1.1	5 x 5 x 2.0	TDK
CDRH4D22/HP	10	144	1.2	5 x 5 x 2.4	Sumida
LQH43PN100MR0	10	247	0.84	4.5 x 3.2 x 2.0	Murata

### 9.1.3 Schottky Diode Selection

The high switching frequency of the TPS61165 demands a high-speed rectification for optimum efficiency. Ensure that the average and peak current rating of the diode exceeds the average output current and peak inductor current. In addition, the reverse breakdown voltage of the diode must exceed the open LED protection voltage. The ONSemiconductor MBR0540 and the ZETEX ZHCS400 are recommended for TPS61165.

### 9.1.4 Compensation Capacitor Selection

The compensation capacitor C3 (see [Functional Block Diagram](#)), connected from COMP pin to GND, is used to stabilize the feedback loop of the TPS61165. A 220-nF ceramic capacitor is suitable for most applications.

### 9.1.5 Input and Output Capacitor Selection

The output capacitor is mainly selected to meet the requirements for the output ripple and loop stability. This ripple voltage is related to the capacitor's capacitance and its equivalent series resistance (ESR). Assuming a capacitor with zero ESR, the minimum capacitance needed for a given ripple can be calculated as shown in [Equation 4](#).

$$C_{\text{out}} = \frac{(V_{\text{out}} - V_{\text{in}}) I_{\text{out}}}{V_{\text{out}} \times F_{\text{s}} \times V_{\text{ripple}}}$$

where

- $V_{\text{ripple}}$  = peak-to-peak output ripple (4)

The additional output ripple component caused by ESR is calculated as shown in [Equation 4](#).

$$V_{\text{ripple\_ESR}} = I_{\text{out}} \times R_{\text{ESR}} \quad (5)$$

Due to its low ESR,  $V_{\text{ripple\_ESR}}$  can be neglected for ceramic capacitors, but must be considered if tantalum or electrolytic capacitors are used.

Care must be taken when evaluating a ceramic capacitors derating under dc bias, aging and AC signal. For example, larger form factor capacitors (in 1206 size) have self-resonant frequencies in the range of the switching frequency. So the effective capacitance is significantly lower. The dc bias can also significantly reduce capacitance. Ceramic capacitors can loss as much as 50% of its capacitance at its rated voltage. Therefore, leave the margin on the voltage rating to ensure adequate capacitance at the required output voltage.

The capacitor in the range of 1  $\mu\text{F}$  to 4.7  $\mu\text{F}$  is recommended for input side. The output requires a capacitor in the range of 1  $\mu\text{F}$  to 10  $\mu\text{F}$ . The output capacitor affects the loop stability of the boost regulator. If the output capacitor is below the range, the boost regulator can potentially become unstable.

The popular vendors for high value ceramic capacitors are:

TDK (<http://www.component.tdk.com/components.php>)

Murata (<http://www.murata.com/cap/index.html>)

## 9.2 Typical Applications

### 9.2.1 TPS61165 Typical Application

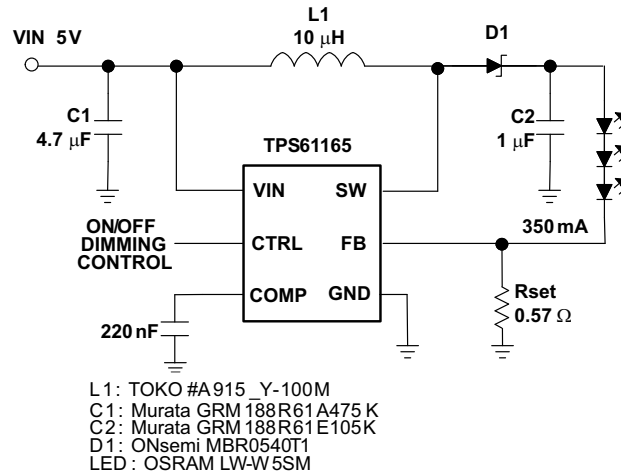

Copyright © 2016, Texas Instruments Incorporated

Figure 8. TPS61165 Typical Application

#### 9.2.1.1 Design Requirements

DESIGN PARAMETERS	EXAMPLE VALUE
Brightness control	PWM dimming
LED current	357 mA

#### 9.2.1.2 Detailed Design Procedure

##### 9.2.1.2.1 LED Brightness Dimming Mode Selection

The TPS61165 features two dimming modes: PWM dimming and EasyScale one-wire digital dimming.

The CTRL pin is used for the control input for both dimming modes, PWM dimming and the 1 wire dimming. The dimming mode for the TPS61165 is selected each time the device is enabled. The default dimming mode is PWM dimming. To enter 1 wire mode, the following digital pattern on the CTRL pin must be recognized by the device every time the device starts from the shutdown mode.

1. Pull CTRL pin high to enable the TPS61165, and to start the 1 wire detection window.
2. After the EasyScale detection delay ( $t_{es\_delay}$ , 100  $\mu\text{s}$ ) expires, drive CTRL low for more than the EasyScale detection time ( $t_{es\_det}$ , 260  $\mu\text{s}$ ).  $t_{es\_det}$  and  $t_{es\_delay}$  values are conservative to guarantee the EasyScale detection taking into account the process and clock variations. To ensure not to enter EasyScale mode, please make sure CTRL pin is never held low for more than 160 $\mu\text{s}$ .
3. The CTRL pin has to be low for more than EasyScale detection time before the EasyScale detection window ( $t_{es\_win}$ , 1 msec) expires. EasyScale detection window starts from the first CTRL pin low to high transition.

The device immediately enters the one-wire mode once the preceding three conditions are met. The EasyScale communication can start before the detection window expires. Once the dimming mode is programmed, it can not be changed without another start up. This means the device needs to be shutdown by pulling the CTRL low for 2.5 ms and restarts. See Figure 9 for a graphical explanation.

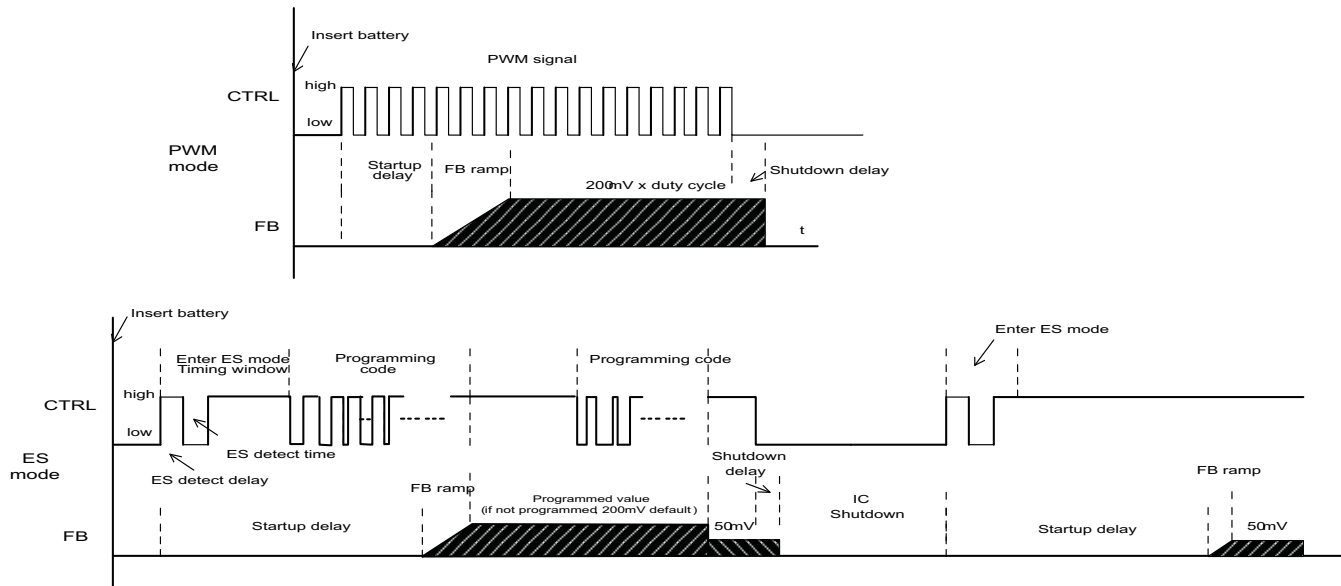

Figure 9. Dimming Mode Detection and Soft Start PWM Brightness Dimming

#### 9.2.1.2.2 PWM Brightness Dimming

When the CTRL pin is constantly high, the FB voltage is regulated to 200 mV typically. However, the CTRL pin allows a PWM signal to reduce this regulation voltage; therefore, it achieves LED brightness dimming. The relationship between the duty cycle and FB voltage is shown in Equation 6.

$$V_{FB} = \text{Duty} \times 200 \text{ mV}$$

where

- Duty = duty cycle of the PWM signal
  - 200 mV = internal reference voltage
- (6)

As shown in Figure 10, the device chops up the internal 200-mV reference voltage at the duty cycle of the PWM signal. The pulse signal is then filtered by an internal low pass filter. The output of the filter is connected to the error amplifier as the reference voltage for the FB pin regulation. Therefore, although a PWM signal is used for brightness dimming, only the WLED DC current is modulated, which is often referred as analog dimming. This eliminates the audible noise which often occurs when the LED current is pulsed in replica of the frequency and duty cycle of PWM control. Unlike other methods which filters the PWM signal for analog dimming, TPS61165 regulation voltage is independent of the PWM logic voltage level which often has large variations.

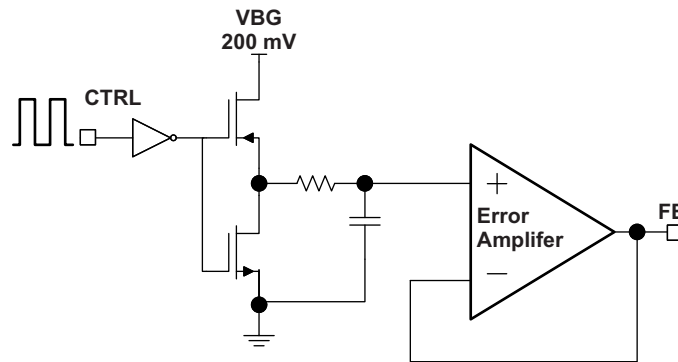

Copyright © 2016, Texas Instruments Incorporated

**Figure 10. Block Diagram of Programmable FB Voltage Using PWM Signal**

For optimum performance, use the PWM dimming frequency in the range of 6.5 kHz to 100 kHz. The requirement of minimum dimming frequency comes from the EasyScale detection delay and detection time specification in the dimming mode selection. Because the CTRL pin is logic only pin, adding an external RC filter applied to the pin does not work.

To use lower PWM dimming, add external RC network connected to the FB pin as shown in [Additional Application Circuits](#).

**9.2.1.2.3 Digital One-Wire Brightness Dimming**

The CTRL pin features a simple digital interface to allow digital brightness control. The digital dimming can save the processor power and battery life as it does not require a PWM signal all the time, and the processor can enter idle mode if available.

The TPS61165 adopts the EasyScale protocol for the digital dimming, which can program the FB voltage to any of the 32 steps with single command. The step increment increases with the voltage to produce pseudo logarithmic curve for the brightness step. See [Table 3](#) for the FB pin voltage steps. The default step is full scale when the device is first enabled ( $V_{FB} = 200\text{ mV}$ ). The programmed reference voltage is stored in an internal register and is not changed by pulling CTRL low for 2.5 ms and then re-enabling the device by taking CTRL high. A power reset clears the register value and reset it to default.

**9.2.1.2.4 EasyScale: One-Wire Digital Dimming**

EasyScale is a simple but flexible one-pin interface to configure the FB voltage. The interface is based on a master-slave structure, where the master is typically a microcontroller or application processor. [Figure 11](#) and [Table 4](#) give an overview of the protocol. The protocol consists of a device specific address byte and a data byte. The device specific address byte is fixed to 72 hex. The data byte consists of five bits for information, two address bits, and the RFA bit. The RFA bit set to high indicates the *Request for Acknowledge* condition. The Acknowledge condition is only applied if the protocol was received correctly. The advantage of EasyScale compared with other on-pin interfaces is that its bit detection is in a large extent independent from the bit transmission rate. It can automatically detect bit rates between 1.7 kBit/sec and up to 160 kBit/sec.

**Table 3. Selectable FB Voltage**

	FB Voltage (mV)	D4	D3	D2	D1	D0
0	0	0	0	0	0	0
1	5	0	0	0	0	1
2	8	0	0	0	1	0
3	11	0	0	0	1	1
4	14	0	0	1	0	0
5	17	0	0	1	0	1

**Table 3. Selectable FB Voltage (continued)**

	FB Voltage (mV)	D4	D3	D2	D1	D0
6	20	0	0	1	1	0
7	23	0	0	1	1	1
8	26	0	1	0	0	0
9	29	0	1	0	0	1
10	32	0	1	0	1	0
11	35	0	1	0	1	1
12	38	0	1	1	0	0
13	44	0	1	1	0	1
14	50	0	1	1	1	0
15	56	0	1	1	1	1
16	62	1	0	0	0	0
17	68	1	0	0	0	1
18	74	1	0	0	1	0
19	80	1	0	0	1	1
20	86	1	0	1	0	0
21	92	1	0	1	0	1
22	98	1	0	1	1	0
23	104	1	0	1	1	1
24	116	1	1	0	0	0
25	128	1	1	0	0	1
26	140	1	1	0	1	0
27	152	1	1	0	1	1
28	164	1	1	1	0	0
29	176	1	1	1	0	1
30	188	1	1	1	1	0
31	200	1	1	1	1	1

DATA IN

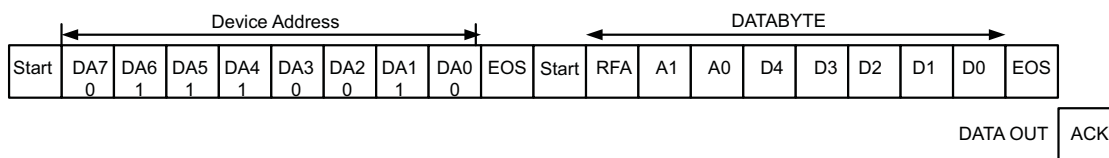

**Figure 11. EasyScale Protocol Overview**

**Table 4. EasyScale Bit Description**

BYTE	BIT NUMBER	NAME	TRANSMISSION DIRECTION	DESCRIPTION
Device Address Byte 72 hex	7	DA7	IN	0 MSB device address
	6	DA6		1
	5	DA5		1
	4	DA4		1
	3	DA3		0
	2	DA2		0
	1	DA1		1
	0	DA0		0 LSB device address

**Table 4. EasyScale Bit Description (continued)**

BYTE	BIT NUMBER	NAME	TRANSMISSION DIRECTION	DESCRIPTION
Data byte	7 (MSB)	RFA	IN	Request for acknowledge. If high, acknowledge is applied by device
	6	A1		0 Address bit 1
	5	A0		0 Address bit 0
	4	D4		Data bit 4
	3	D3		Data bit 3
	2	D2		Data bit 2
	1	D1		Data bit 1
	0 (LSB)	D0		Data bit 0
		ACK	OUT	Acknowledge condition active 0, this condition is only applied in case RFA bit is set. Open drain output, line must be pulled high by the host with a pullup resistor. This feature can only be used if the master has an open-drain output stage. In case of a push-pull output stage Acknowledge condition may not be requested!

**EasyScale Timing, without acknowledge RFA = 0**

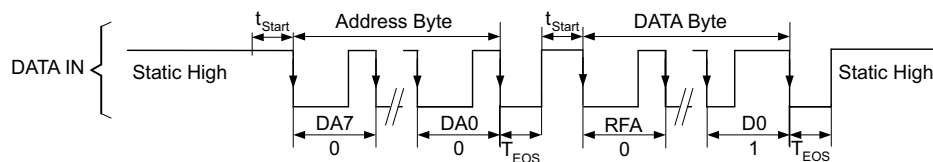

**EasyScale Timing, with acknowledge RFA = 1**

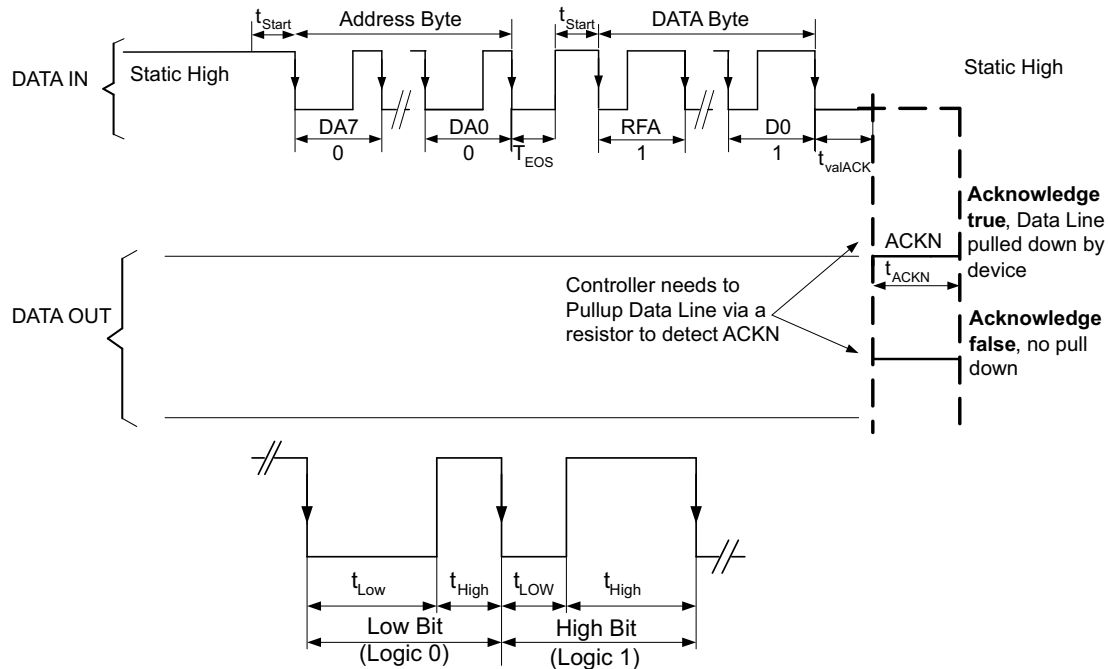

**Figure 12. EasyScale — Bit Coding**

All bits are transmitted MSB first and LSB last. [Figure 12](#) shows the protocol without acknowledge request (Bit RFA = 0), [Figure 12](#) with acknowledge (Bit RFA = 1) request. Prior to both bytes, device address byte and data byte, a start condition must be applied. For this, the CTRL pin must be pulled high for at least  $t_{start}$  (2  $\mu$ s) before the bit transmission starts with the falling edge. If the CTRL pin is already at a high level, no start condition is needed prior to the device address byte. The transmission of each byte is closed with an End of Stream condition for at least  $t_{EOS}$  (2  $\mu$ s).

The bit detection is based on a Logic Detection scheme, where the criterion is the relation between  $t_{LOW}$  and  $t_{HIGH}$ . It can be simplified to:

High Bit:  $t_{HIGH} > t_{LOW}$ , but with  $t_{HIGH}$  at least  $2x t_{LOW}$ , see [Figure 12](#).

Low Bit:  $t_{HIGH} < t_{LOW}$ , but with  $t_{LOW}$  at least  $2x t_{HIGH}$ , see [Figure 12](#).

The bit detection starts with a falling edge on the CTRL pin and ends with the next falling edge. Depending on the relation between  $t_{HIGH}$  and  $t_{LOW}$ , the logic 0 or 1 is detected.

The acknowledge condition is only applied if:

- Acknowledge is requested by a set RFA bit.
- The transmitted device address matches with the device address of the device.
- 16 bits is received correctly.

If the device turns on the internal ACKN-MOSFET and pulls the CTRL pin low for the time  $t_{ACKN}$ , which is  $512 \mu s$  maximum then the Acknowledge condition is valid after an internal delay time  $t_{valACK}$ . This means that the internal ACKN-MOSFET is turned on after  $t_{valACK}$ , when the last falling edge of the protocol was detected. The master controller keeps the line low in this period. The master device can detect the acknowledge condition with its input by releasing the CTRL pin after  $t_{valACK}$  and read back a logic 0. The CTRL pin can be used again after the acknowledge condition ends.

The acknowledge condition may be requested only if the master device has an open drain output. For a push-pull output stage, the use a series resistor in the CTRL line to limit the current to  $500 \mu A$  is recommended for such cases as:

- accidentally requested acknowledge, or
- to protect the internal ACKN-MOSFET.

### 9.2.1.2.5 Current Program

The FB voltage is regulated by a low 0.2-V reference voltage. The LED current is programmed externally using a current-sense resistor in series with the LED string. The value of the  $R_{SET}$  is calculated using [Equation 7](#).

$$I_{LED} = \frac{V_{FB}}{R_{SET}}$$

where

- $I_{LED}$  = output current of LEDs
- $V_{FB}$  = regulated voltage of FB
- $R_{SET}$  = current sense resistor

(7)

The output current tolerance depends on the FB accuracy and the current sensor resistor accuracy.

### 9.2.1.3 Application Curves

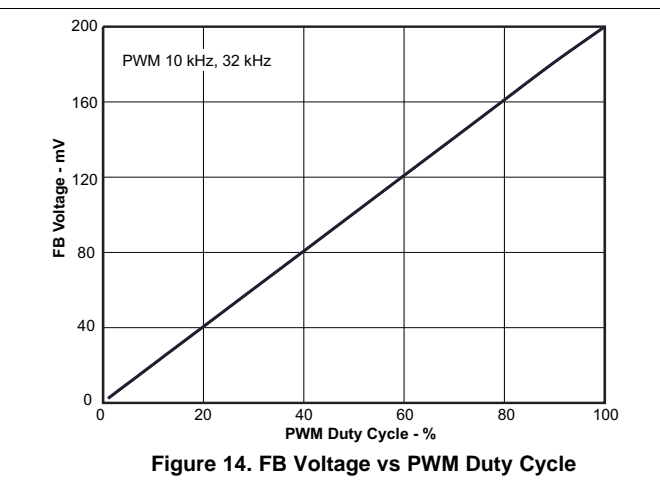
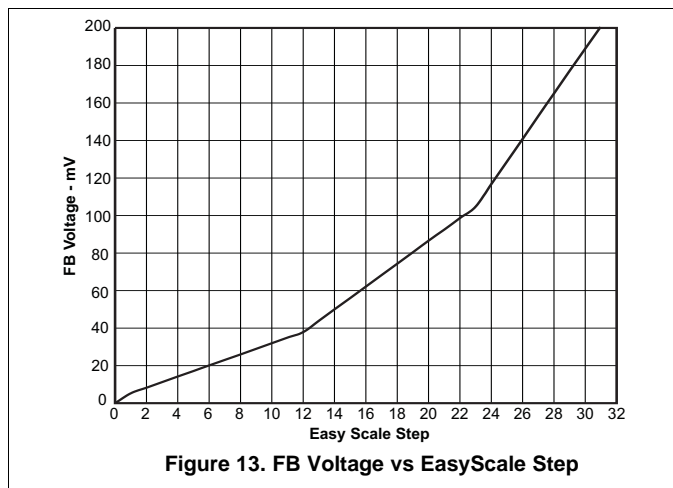

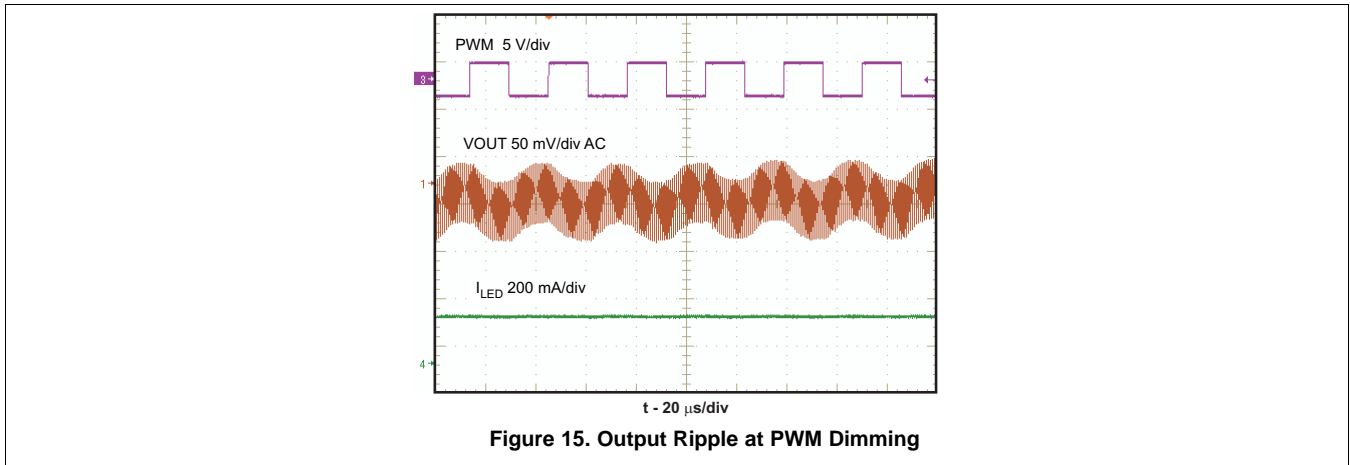

### 9.2.2 Additional Application Circuits

The TPS61165 can be configured to drive three high-brightness LEDs using an external PWM dimming network. [Figure 16](#) shows an example application circuit.

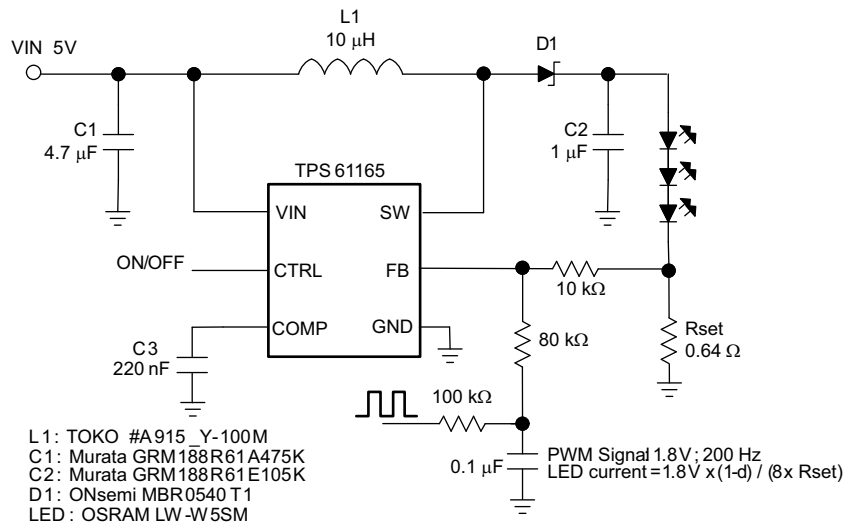

Copyright © 2016, Texas Instruments Incorporated

**Figure 16. Drive Three High-Brightness LEDs With External PWM Dimming Network**

The TPS61165 can be configured to drive nine strings of three LEDs for media form factor displays. [Figure 17](#) shows an example application circuit.

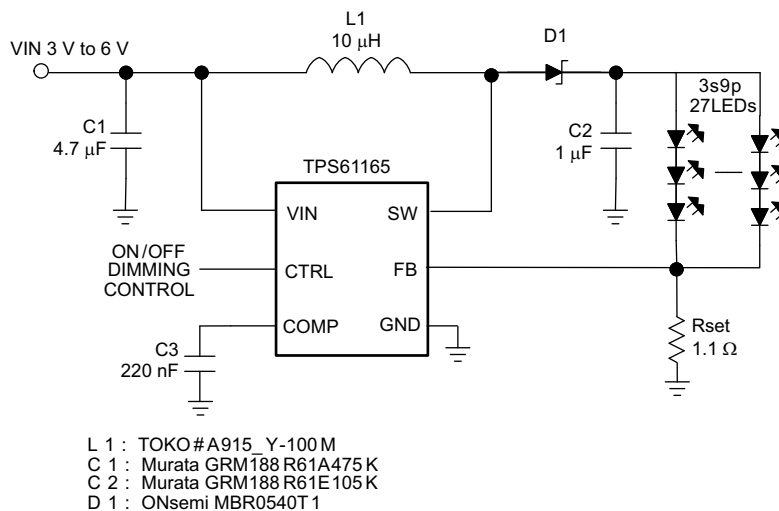

Copyright © 2016, Texas Instruments Incorporated

**Figure 17. Drive 27 LEDs for Media Form-Factor Display**

The TPS61165 can be configured to drive six high-brightness LEDs in series. [Figure 18](#) provides an example applications circuit.

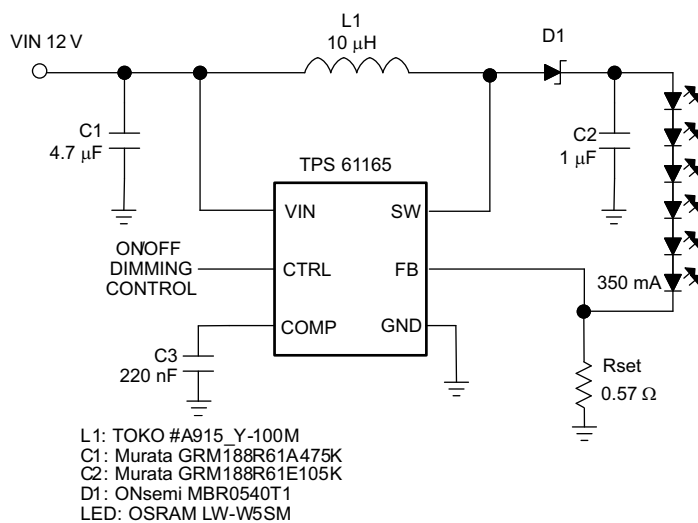

Copyright © 2016, Texas Instruments Incorporated

**Figure 18. Drive Six High-Brightness LEDs**

The TPS61165 can be configured to drive four high-brightness LEDs using SEPIC topology. An example application circuit can be found in [Figure 19](#).

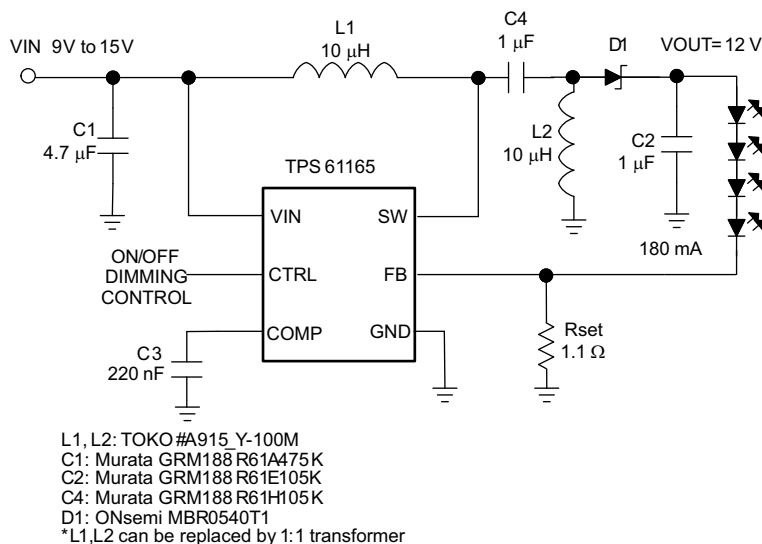

Copyright © 2016, Texas Instruments Incorporated

**Figure 19. Drive Four High-Brightness LED With SEPIC Topology**

### 9.3 Do's and Don'ts

There is a known issue with the TPS61165 when using the EasyScale interface to increase the feedback voltage. When  $V_{FB}$  is increased from 0 mV to any value above 0 mV, some ICs do not properly soft start during this transition and the voltage on their SW pin overshoots. If the overshoot exceeds the absolute maximum voltage rating on the SW pin, the device is damaged.

With  $V_{FB}$  set below 10 mV through EasyScale, the parasitic offsets on the input pins of the internal transconductance amplifier determine the value of output of the amplifier. Device process variations are causing the offset to be larger and in the opposite polarity than expected. If the amplifier's output is already high prior to a transition from  $V_{FB} = 0$  mV to any other voltage, then the modulator turns on full, bypassing soft start, and causes the SW pin and output voltage to overshoot.

To avoid this issue do not use EasyScale to change the feedback voltage from 0 mV, effectively disabling the device, to any other voltage. One alternative is to start with  $V_{FB} = 10$  mV and go to a higher voltage. Another alternative is to disable the device by taking the CTRL pin low for 2.5 ms and then re-enter EasyScale to force a soft start from  $V_{FB} = 0$  mV to the default 200 mV.

## 10 Power Supply Recommendations

The TPS61165 requires a single supply input voltage. This voltage can range from 3 V to 18 V and be able to supply enough current for a given application.

## 11 Layout

### 11.1 Layout Guidelines

As for all switching power supplies, especially those high frequency and high current ones, layout is an important design step. If layout is not carefully done, the regulator could suffer from instability as well as noise problems. To reduce switching losses, the SW pin rise and fall times are made as short as possible. To prevent radiation of high frequency resonance problems, proper layout of the high frequency switching path is essential. Minimize the length and area of all traces connected to the SW pin, and always use a ground plane under the switching regulator to minimize inter-plane coupling. The loop including the PWM switch, Schottky diode, and output capacitor, contains high current rising and falling in nanosecond and must be kept as short as possible. The input capacitor must be close to both the VIN pin and the GND pin to reduce the device supply ripple. Figure 20 shows a sample layout.

### 11.2 Layout Example

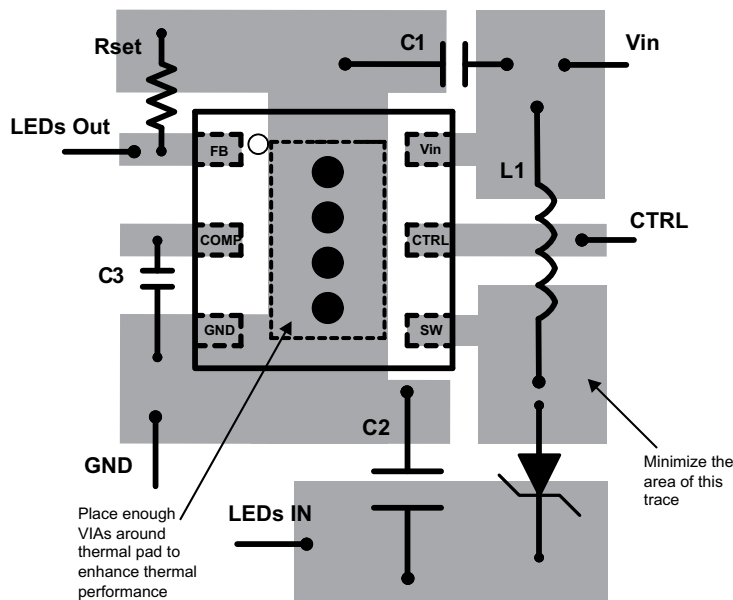

Figure 20. Layout Recommendation

### 11.3 Thermal Considerations

The maximum device junction temperature must be restricted to 125°C under normal operating conditions. This restriction limits the power dissipation of the TPS61165. Calculate the maximum allowable dissipation,  $P_{D(max)}$ , and keep the actual dissipation less than or equal to  $P_{D(max)}$ . The maximum-power-dissipation limit is determined using [Equation 8](#):

$$P_{D(max)} = \frac{125^{\circ}\text{C} - T_A}{R_{\theta JA}}$$

where

- $T_A$  is the maximum ambient temperature for the application
- $R_{\theta JA}$  is the thermal resistance junction-to-ambient given in [Thermal Information](#) (8)

The TPS61165 comes in a thermally enhanced QFN package. This package includes a thermal pad that improves the thermal capabilities of the package. The  $R_{\theta JA}$  of the QFN package greatly depends on the PCB layout and thermal pad connection. The thermal pad must be soldered to the analog ground on the PCB. Using thermal vias underneath the thermal pad as illustrated in the layout example. Also see the *QFN/SON PCB Attachment* application report ([SLUA271](#)).

## 12 Device and Documentation Support

### 12.1 Device Support

#### 12.1.1 Third-Party Products Disclaimer

TI'S PUBLICATION OF INFORMATION REGARDING THIRD-PARTY PRODUCTS OR SERVICES DOES NOT CONSTITUTE AN ENDORSEMENT REGARDING THE SUITABILITY OF SUCH PRODUCTS OR SERVICES OR A WARRANTY, REPRESENTATION OR ENDORSEMENT OF SUCH PRODUCTS OR SERVICES, EITHER ALONE OR IN COMBINATION WITH ANY TI PRODUCT OR SERVICE.

### 12.2 Documentation Support

#### 12.2.1 Related Documentation

For related documentation see the following:

*QFN/SON PCB Attachment* ([SLUA271](#))

### 12.3 Community Resources

The following links connect to TI community resources. Linked contents are provided "AS IS" by the respective contributors. They do not constitute TI specifications and do not necessarily reflect TI's views; see TI's [Terms of Use](#).

**TI E2E™ Online Community** *TI's Engineer-to-Engineer (E2E) Community*. Created to foster collaboration among engineers. At [e2e.ti.com](#), you can ask questions, share knowledge, explore ideas and help solve problems with fellow engineers.

**Design Support** *TI's Design Support* Quickly find helpful E2E forums along with design support tools and contact information for technical support.

### 12.4 Trademarks

EasyScale, E2E are trademarks of Texas Instruments.  
All other trademarks are the property of their respective owners.

### 12.5 Electrostatic Discharge Caution



These devices have limited built-in ESD protection. The leads should be shorted together or the device placed in conductive foam during storage or handling to prevent electrostatic damage to the MOS gates.

### 12.6 Glossary

[SLYZ022](#) — *TI Glossary*.

This glossary lists and explains terms, acronyms, and definitions.

## 13 Mechanical, Packaging, and Orderable Information

The following pages include mechanical, packaging, and orderable information. This information is the most current data available for the designated devices. This data is subject to change without notice and revision of this document. For browser-based versions of this data sheet, refer to the left-hand navigation.

## PACKAGING INFORMATION

Orderable Device	Status (1)	Package Type	Package Drawing	Pins	Package Qty	Eco Plan (2)	Lead finish/ Ball material (6)	MSL Peak Temp (3)	Op Temp (°C)	Device Marking (4/5)	Samples
TPS61165DBVR	ACTIVE	SOT-23	DBV	6	3000	RoHS & Green	NIPDAU	Level-1-260C-UNLIM	-40 to 85	DAK	<a href="#">Samples</a>
TPS61165DBVT	ACTIVE	SOT-23	DBV	6	250	RoHS & Green	NIPDAU	Level-1-260C-UNLIM	-40 to 85	DAK	<a href="#">Samples</a>
TPS61165DRVR	ACTIVE	WSON	DRV	6	3000	RoHS & Green	NIPDAU   NIPDAUAG	Level-2-260C-1 YEAR	-40 to 85	CCQ	<a href="#">Samples</a>
TPS61165DRVRG4	ACTIVE	WSON	DRV	6	3000	RoHS & Green	NIPDAU	Level-2-260C-1 YEAR	-40 to 85	CCQ	<a href="#">Samples</a>
TPS61165DRVVT	ACTIVE	WSON	DRV	6	250	RoHS & Green	NIPDAU   NIPDAUAG	Level-2-260C-1 YEAR	-40 to 85	CCQ	<a href="#">Samples</a>
TPS61165DRVVG4	ACTIVE	WSON	DRV	6	250	RoHS & Green	NIPDAU	Level-2-260C-1 YEAR	-40 to 85	CCQ	<a href="#">Samples</a>

(1) The marketing status values are defined as follows:

**ACTIVE:** Product device recommended for new designs.

**LIFEBUY:** TI has announced that the device will be discontinued, and a lifetime-buy period is in effect.

**NRND:** Not recommended for new designs. Device is in production to support existing customers, but TI does not recommend using this part in a new design.

**PREVIEW:** Device has been announced but is not in production. Samples may or may not be available.

**OBSELETE:** TI has discontinued the production of the device.

(2) **RoHS:** TI defines "RoHS" to mean semiconductor products that are compliant with the current EU RoHS requirements for all 10 RoHS substances, including the requirement that RoHS substance do not exceed 0.1% by weight in homogeneous materials. Where designed to be soldered at high temperatures, "RoHS" products are suitable for use in specified lead-free processes. TI may reference these types of products as "Pb-Free".

**RoHS Exempt:** TI defines "RoHS Exempt" to mean products that contain lead but are compliant with EU RoHS pursuant to a specific EU RoHS exemption.

**Green:** TI defines "Green" to mean the content of Chlorine (Cl) and Bromine (Br) based flame retardants meet JS709B low halogen requirements of <=1000ppm threshold. Antimony trioxide based flame retardants must also meet the <=1000ppm threshold requirement.

(3) MSL, Peak Temp. - The Moisture Sensitivity Level rating according to the JEDEC industry standard classifications, and peak solder temperature.

(4) There may be additional marking, which relates to the logo, the lot trace code information, or the environmental category on the device.

(5) Multiple Device Markings will be inside parentheses. Only one Device Marking contained in parentheses and separated by a "~" will appear on a device. If a line is indented then it is a continuation of the previous line and the two combined represent the entire Device Marking for that device.

(6) Lead finish/Ball material - Orderable Devices may have multiple material finish options. Finish options are separated by a vertical ruled line. Lead finish/Ball material values may wrap to two lines if the finish value exceeds the maximum column width.

**Important Information and Disclaimer:** The information provided on this page represents TI's knowledge and belief as of the date that it is provided. TI bases its knowledge and belief on information provided by third parties, and makes no representation or warranty as to the accuracy of such information. Efforts are underway to better integrate information from third parties. TI has taken and continues to take reasonable steps to provide representative and accurate information but may not have conducted destructive testing or chemical analysis on incoming materials and chemicals. TI and TI suppliers consider certain information to be proprietary, and thus CAS numbers and other limited information may not be available for release.

In no event shall TI's liability arising out of such information exceed the total purchase price of the TI part(s) at issue in this document sold by TI to Customer on an annual basis.

**OTHER QUALIFIED VERSIONS OF TPS61165 :**

- Automotive : [TPS61165-Q1](#)

NOTE: Qualified Version Definitions:

- Automotive - Q100 devices qualified for high-reliability automotive applications targeting zero defects

**TAPE AND REEL INFORMATION**

**QUADRANT ASSIGNMENTS FOR PIN 1 ORIENTATION IN TAPE**

\*All dimensions are nominal

Device	Package Type	Package Drawing	Pins	SPQ	Reel Diameter (mm)	Reel Width W1 (mm)	A0 (mm)	B0 (mm)	K0 (mm)	P1 (mm)	W (mm)	Pin1 Quadrant
TPS61165DBVR	SOT-23	DBV	6	3000	179.0	8.4	3.2	3.2	1.4	4.0	8.0	Q3
TPS61165DBVT	SOT-23	DBV	6	250	179.0	8.4	3.2	3.2	1.4	4.0	8.0	Q3
TPS61165DRVR	WSO	DRV	6	3000	180.0	8.4	2.3	2.3	1.15	4.0	8.0	Q2
TPS61165DRVT	WSO	DRV	6	250	180.0	8.4	2.3	2.3	1.15	4.0	8.0	Q2

**TAPE AND REEL BOX DIMENSIONS**

\*All dimensions are nominal

Device	Package Type	Package Drawing	Pins	SPQ	Length (mm)	Width (mm)	Height (mm)
TPS61165DBVR	SOT-23	DBV	6	3000	200.0	183.0	25.0
TPS61165DBVT	SOT-23	DBV	6	250	200.0	183.0	25.0
TPS61165DRVR	WSON	DRV	6	3000	210.0	185.0	35.0
TPS61165DRVT	WSON	DRV	6	250	210.0	185.0	35.0



# EXAMPLE BOARD LAYOUT

DBV0006A

SOT-23 - 1.45 mm max height

SMALL OUTLINE TRANSISTOR



LAND PATTERN EXAMPLE  
EXPOSED METAL SHOWN  
SCALE:15X

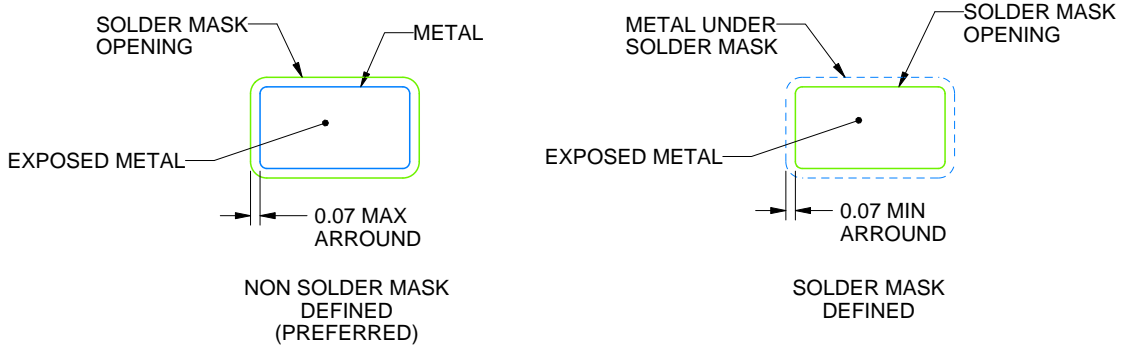

SOLDER MASK DETAILS

4214840/E 02/2024

NOTES: (continued)

- 6. Publication IPC-7351 may have alternate designs.
- 7. Solder mask tolerances between and around signal pads can vary based on board fabrication site.

# EXAMPLE STENCIL DESIGN

DBV0006A

SOT-23 - 1.45 mm max height

SMALL OUTLINE TRANSISTOR

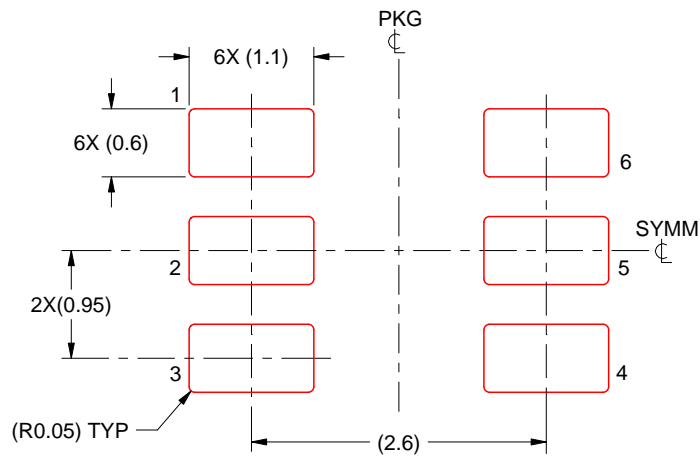

SOLDER PASTE EXAMPLE  
BASED ON 0.125 mm THICK STENCIL  
SCALE:15X

4214840/E 02/2024

NOTES: (continued)

8. Laser cutting apertures with trapezoidal walls and rounded corners may offer better paste release. IPC-7525 may have alternate design recommendations.
9. Board assembly site may have different recommendations for stencil design.

## GENERIC PACKAGE VIEW

DRV 6

WSON - 0.8 mm max height

PLASTIC SMALL OUTLINE - NO LEAD



Images above are just a representation of the package family, actual package may vary.  
Refer to the product data sheet for package details.

4206925/F



4222173/B 04/2018

NOTES:

1. All linear dimensions are in millimeters. Any dimensions in parenthesis are for reference only. Dimensioning and tolerancing per ASME Y14.5M.
2. This drawing is subject to change without notice.
3. The package thermal pad must be soldered to the printed circuit board for thermal and mechanical performance.



# EXAMPLE STENCIL DESIGN

DRV0006A

WSON - 0.8 mm max height

PLASTIC SMALL OUTLINE - NO LEAD



SOLDER PASTE EXAMPLE  
BASED ON 0.125 mm THICK STENCIL

EXPOSED PAD #7  
88% PRINTED SOLDER COVERAGE BY AREA UNDER PACKAGE  
SCALE:30X

4222173/B 04/2018

NOTES: (continued)

6. Laser cutting apertures with trapezoidal walls and rounded corners may offer better paste release. IPC-7525 may have alternate design recommendations.

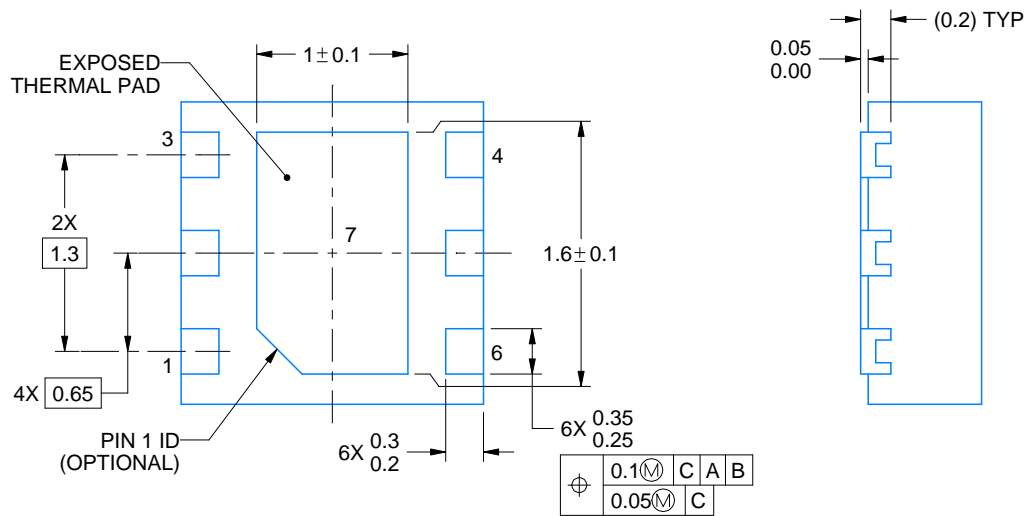
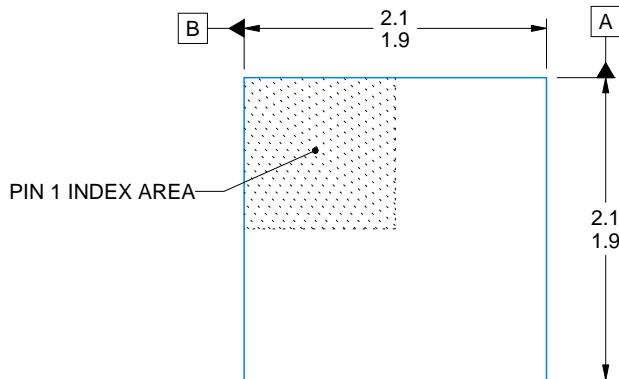
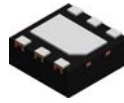

4225563/A 12/2019

NOTES:

1. All linear dimensions are in millimeters. Any dimensions in parenthesis are for reference only. Dimensioning and tolerancing per ASME Y14.5M.
2. This drawing is subject to change without notice.
3. The package thermal pad must be soldered to the printed circuit board for thermal and mechanical performance.

# EXAMPLE BOARD LAYOUT

DRV0006D

WSON - 0.8 mm max height

PLASTIC SMALL OUTLINE - NO LEAD



LAND PATTERN EXAMPLE  
EXPOSED METAL SHOWN  
SCALE:25X



SOLDER MASK DETAILS

4225563/A 12/2019

NOTES: (continued)

4. This package is designed to be soldered to a thermal pad on the board. For more information, see Texas Instruments literature number SLUA271 ([www.ti.com/lit/sluea271](http://www.ti.com/lit/sluea271)).
5. Vias are optional depending on application, refer to device data sheet. If some or all are implemented, recommended via locations are shown.

# EXAMPLE STENCIL DESIGN

DRV0006D

WSON - 0.8 mm max height

PLASTIC SMALL OUTLINE - NO LEAD



SOLDER PASTE EXAMPLE  
BASED ON 0.125 mm THICK STENCIL

EXPOSED PAD #7  
88% PRINTED SOLDER COVERAGE BY AREA UNDER PACKAGE  
SCALE:30X

4225563/A 12/2019

NOTES: (continued)

6. Laser cutting apertures with trapezoidal walls and rounded corners may offer better paste release. IPC-7525 may have alternate design recommendations.

## IMPORTANT NOTICE AND DISCLAIMER

TI PROVIDES TECHNICAL AND RELIABILITY DATA (INCLUDING DATA SHEETS), DESIGN RESOURCES (INCLUDING REFERENCE DESIGNS), APPLICATION OR OTHER DESIGN ADVICE, WEB TOOLS, SAFETY INFORMATION, AND OTHER RESOURCES "AS IS" AND WITH ALL FAULTS, AND DISCLAIMS ALL WARRANTIES, EXPRESS AND IMPLIED, INCLUDING WITHOUT LIMITATION ANY IMPLIED WARRANTIES OF MERCHANTABILITY, FITNESS FOR A PARTICULAR PURPOSE OR NON-INFRINGEMENT OF THIRD PARTY INTELLECTUAL PROPERTY RIGHTS.

These resources are intended for skilled developers designing with TI products. You are solely responsible for (1) selecting the appropriate TI products for your application, (2) designing, validating and testing your application, and (3) ensuring your application meets applicable standards, and any other safety, security, regulatory or other requirements.

These resources are subject to change without notice. TI grants you permission to use these resources only for development of an application that uses the TI products described in the resource. Other reproduction and display of these resources is prohibited. No license is granted to any other TI intellectual property right or to any third party intellectual property right. TI disclaims responsibility for, and you will fully indemnify TI and its representatives against, any claims, damages, costs, losses, and liabilities arising out of your use of these resources.

TI's products are provided subject to [TI's Terms of Sale](#) or other applicable terms available either on [ti.com](https://www.ti.com) or provided in conjunction with such TI products. TI's provision of these resources does not expand or otherwise alter TI's applicable warranties or warranty disclaimers for TI products.

TI objects to and rejects any additional or different terms you may have proposed.

Mailing Address: Texas Instruments, Post Office Box 655303, Dallas, Texas 75265  
Copyright © 2024, Texas Instruments Incorporated

## Looking for pricing, stock, or lifecycle information?

Click below to explore more details on WIN SOURCE:

 [View TPS61165DBVR on WIN SOURCE](#)

 [Texas Instruments](#) Information

## Optimize Your Supply Chain with WIN SOURCE Solutions

-  Global Sourcing Solution
-  Obsolete Management
-  Cost Control Management
-  Shortage Management
-  Alternative Solution
-  Excess Inventory Management