



**THE DATASHEET OF  
TPS61150DRCR**



## TPS6115x Dual-Output Boost WLED Driver Using Single Inductor

### 1 Features

- 2.5-V to 6-V Input Voltage Range
- Two Outputs Each up to 27 V
- 0.7-A Integrated Switch
- Built-In Power Diode
- 1.2-MHz Fixed PWM Frequency
- Individually Programmable Output Current
- Input-to-Output Isolation
- Built-In Soft Start
- Overvoltage Protection
- Up to 83% Efficiency
- Up to 30-kHz PWM Dimming Frequency

### 2 Applications

- Sub- and Main-Display Backlight in Clamshell Phones
- Display and Keypad Backlight
- Up to 14-WLED Driver

### 3 Description

The TPS6115x is a high-frequency boost converter with two regulated current outputs for driving WLEDs. Each current output can be individually programmed through external resistors. There is a dedicated selection pin for each output so the two outputs can be turned on separately or simultaneously. The output current can be reduced by a pulse width modulation (PWM) signal on SEL pins or an analog voltage on the ISET pins, resulting in PWM dimming of the WLEDs. The boost regulator runs at a 1.2-MHz fixed switching frequency to reduce output ripple and avoid audible noises associated with pulse frequency modulation (PFM) control.

The two current outputs are ideal for driving WLED backlights for the sub and main displays in clamshell phones. The two outputs can also be used for driving display and keypad backlights. When used together, the two outputs can drive up to 14 WLEDs for one large display.

In addition to the small inductor, small capacitor, and 3-mm × 3-mm VSON package, the built-in MOSFET and diode eliminate the need for any external power devices. Overall, the device provides an extremely compact solution with high efficiency and plenty of flexibility.

#### Device Information<sup>(1)</sup>

PART NUMBER	PACKAGE	BODY SIZE (NOM)
TPS61150	VSON (10)	3.00 mm × 3.00 mm
TPS61151		

(1) For all available packages, see the orderable addendum at the end of the data sheet.

#### Typical Application

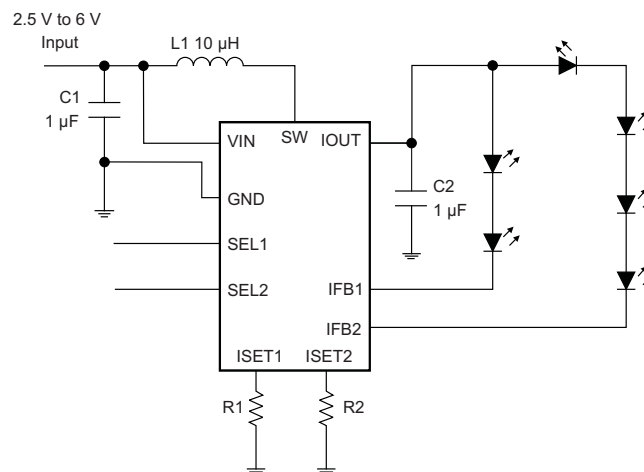

## Table of Contents

<b>1 Features</b> .....	<b>1</b>	8.4 Device Functional Modes.....	<b>9</b>
<b>2 Applications</b> .....	<b>1</b>	<b>9 Application and Implementation</b> .....	<b>10</b>
<b>3 Description</b> .....	<b>1</b>	9.1 Application Information.....	<b>10</b>
<b>4 Revision History</b> .....	<b>2</b>	9.2 Typical Application .....	<b>10</b>
<b>5 Device Comparison Tables</b> .....	<b>3</b>	9.3 Additional Application Circuits.....	<b>16</b>
<b>6 Pin Configuration and Functions</b> .....	<b>3</b>	<b>10 Power Supply Recommendations</b> .....	<b>17</b>
<b>7 Specifications</b> .....	<b>4</b>	<b>11 Layout</b> .....	<b>17</b>
7.1 Absolute Maximum Ratings .....	<b>4</b>	11.1 Layout Guidelines .....	<b>17</b>
7.2 ESD Ratings.....	<b>4</b>	11.2 Layout Example .....	<b>17</b>
7.3 Recommended Operating Conditions.....	<b>4</b>	<b>12 Device and Documentation Support</b> .....	<b>18</b>
7.4 Thermal Information .....	<b>4</b>	12.1 Device Support.....	<b>18</b>
7.5 Electrical Characteristics.....	<b>5</b>	12.2 Related Links .....	<b>18</b>
7.6 Typical Characteristics .....	<b>6</b>	12.3 Community Resources.....	<b>18</b>
<b>8 Detailed Description</b> .....	<b>8</b>	12.4 Trademarks .....	<b>18</b>
8.1 Overview .....	<b>8</b>	12.5 Electrostatic Discharge Caution.....	<b>18</b>
8.2 Functional Block Diagram .....	<b>8</b>	12.6 Glossary .....	<b>18</b>
8.3 Feature Description.....	<b>8</b>	<b>13 Mechanical, Packaging, and Orderable Information</b> .....	<b>18</b>

## 4 Revision History

NOTE: Page numbers for previous revisions may differ from page numbers in the current version.

### Changes from Revision D (July 2009) to Revision E

Page

• Changed "QFN" package to "VSON" throughout document .....	<b>1</b>
• Added <i>Device Information</i> and <i>Pin Configuration and Functions</i> sections, <i>ESD Ratings</i> and <i>Thermal Information</i> tables, <i>Feature Description</i> , <i>Device Functional Modes</i> , <i>Application and Implementation</i> , <i>Power Supply Recommendations</i> , <i>Layout</i> , <i>Device and Documentation Support</i> , and <i>Mechanical, Packaging, and Orderable Information</i> sections.....	<b>1</b>
• Deleted obsolete <i>Dissipation Ratings</i> table .....	<b>5</b>

### Changes from Revision C (November 2008) to Revision D

Page

• Deleted <i>Lead temperature</i> specification from <i>Absolute Maximum Ratings</i> table.....	<b>4</b>
• Corrected FET error in <a href="#">Figure 9</a> .....	<b>11</b>

## 5 Device Comparison Tables

**Table 1. OVP Options**

T <sub>A</sub>	PACKAGE <sup>(1)</sup>	OVP (TYPICAL)	PACKAGE MARKING
–40 to +85°C	TPS61150DRCR	28 V	BCQ
–40 to +85°C	TPS61151DRCR	22 V	BRH
–40 to +85°C	TPS61150DRCT	28 V	BCQ
–40 to +85°C	TPS61151DRCT	22 V	BRH

(1) For the most current package and ordering information, see the Package Option Addendum at the end of this document, or see the TI web site at [www.ti.com](http://www.ti.com).

**Table 2. TPS6115x Mode Selection**

SEL1	SEL2	IFB1	IFB2
H	L	Enable	Disable
L	H	Disable	Enable
H	H	Enable	Enable
L	L	Device shutdown	

## 6 Pin Configuration and Functions

**DRC Package**  
**10-Pin VSON With Exposed Thermal Pad**  
**Top View**

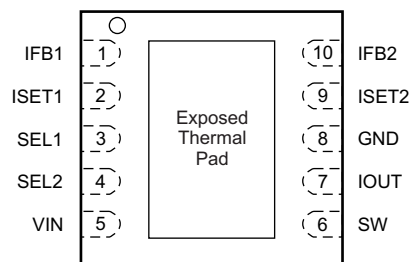
**Pin Functions**

PIN		I/O	DESCRIPTION
NUMBER	NAME		
1, 10	IFB1, IFB2	I	The return path for the I <sub>OUT</sub> regulation. Current regulator is connected to this pin, and it can be disabled to open the current path.
2, 9	ISET1, ISET2	I	Output current programming pins. The resistor connected to the pin programs its corresponding output current.
3, 4	SEL1, SEL2	I	Mode selection pins. See <a href="#">Table 2</a> for details.
5	VIN	I	The input pin to the device. It provides the current to the boost power stage and also powers the device circuit. When V <sub>IN</sub> is below the undervoltage lockout threshold, the device turns off and disables outputs, thus disconnecting the WLEDs from the input.
6	SW	I	This is the switching node of the device.
7	IOU	O	The output of the constant current supply. It is directly connected to the boost converter output.
8	GND	O	The ground of the device. Connect the input and output capacitors very close to this pin.
—	Thermal Pad	—	The thermal pad should be soldered to the analog ground. If possible, use thermal via to connect to ground plane for ideal power dissipation.

## 7 Specifications

### 7.1 Absolute Maximum Ratings

over operating free-air temperature range (unless otherwise noted)<sup>(1)(2)</sup>

	MIN	MAX	UNIT
Supply voltages on pin VIN <sup>(2)</sup>	-0.3		V
Voltages on pins SEL1, SEL2, ISET1 and ISET2 <sup>(2)</sup>	-0.3		V
Voltage on pin IOOUT, SW, IFB1 and IFB2 <sup>(2)</sup>		30	V
Operating junction temperature	-40	150	°C
Storage temperature, T <sub>stg</sub>	-65	150	°C

- (1) Stresses beyond those listed under *Absolute Maximum Ratings* may cause permanent damage to the device. These are stress ratings only, which do not imply functional operation of the device at these or any other conditions beyond those indicated under *Recommended Operating Conditions*. Exposure to absolute-maximum-rated conditions for extended periods may affect device reliability.
- (2) All voltage values are with respect to network ground pin.

### 7.2 ESD Ratings

		VALUE	UNIT
V <sub>(ESD)</sub>	Electrostatic discharge	Human-body model (HBM), per ANSI/ESDA/JEDEC JS-001 <sup>(1)</sup>	±2000
		Charged-device model (CDM), per JEDEC specification JESD22-C101 <sup>(2)</sup>	±1500

- (1) JEDEC document JEP155 states that 500-V HBM allows safe manufacturing with a standard ESD control process.
- (2) JEDEC document JEP157 states that 250-V CDM allows safe manufacturing with a standard ESD control process.

### 7.3 Recommended Operating Conditions

over operating free-air temperature range (unless otherwise noted).

		MIN	NOM	MAX	UNIT
V <sub>I</sub>	Input voltage	2.5		6	V
V <sub>O</sub>	Output voltage	V <sub>IN</sub>		27	V
L	Inductor <sup>(1)</sup>		10		μH
C <sub>IN</sub>	Input capacitor <sup>(1)</sup>	1			μF
C <sub>O</sub>	Output capacitor <sup>(1)</sup>	1			μF
T <sub>A</sub>	Operating ambient temperature	-40		85	°C
T <sub>J</sub>	Operating junction temperature	-40		125	°C

- (1) See the [Application and Implementation](#) section for further information.

### 7.4 Thermal Information

THERMAL METRIC <sup>(1)</sup>		TPS6115x	UNIT
		DRC (VSON)	
		10 PINS	
R <sub>θJA</sub>	Junction-to-ambient thermal resistance	44.3	°C/W
R <sub>θJC(top)</sub>	Junction-to-case (top) thermal resistance	56.1	°C/W
R <sub>θJB</sub>	Junction-to-board thermal resistance	19.2	°C/W
ψ <sub>JT</sub>	Junction-to-top characterization parameter	0.7	°C/W
ψ <sub>JB</sub>	Junction-to-board characterization parameter	19.4	°C/W
R <sub>θJC(bot)</sub>	Junction-to-case (bottom) thermal resistance	5.5	°C/W

- (1) For more information about traditional and new thermal metrics, see the *Semiconductor and IC Package Thermal Metrics* application report, [SPRA953](#).

## 7.5 Electrical Characteristics

At  $V_I = 3.6\text{ V}$ ,  $\text{SELx} = V_{\text{IN}}$ ,  $R_{\text{SET}} = 80\text{ k}\Omega$ ,  $V_{\text{IO}} = 15\text{ V}$ , and  $T_A = -40^\circ\text{C}$  to  $+85^\circ\text{C}$ . Typical values are at  $T_A = 25^\circ\text{C}$  (unless otherwise noted).

PARAMETER		TEST CONDITIONS	MIN	TYP	MAX	UNIT
<b>SUPPLY CURRENT</b>						
$V_I$	Input voltage range		2.5		6	V
$I_Q$	Operating quiescent current into $V_{\text{IN}}$	Device PWM switching no load			2	mA
$I_{\text{SD}}$	Shutdown current	SELx = GND			1.5	$\mu\text{A}$
$V_{\text{UVLO}}$	Undervoltage lockout threshold	$V_{\text{IN}}$ falling		1.65	1.8	V
$V_{\text{hys}}$	Undervoltage lockout hysteresis			70		mV
<b>ENABLE AND SOFT START</b>						
$V_{(\text{selh})}$	SEL logic high voltage	$V_{\text{IN}} = 2.7\text{ V to }6\text{ V}$	1.2			V
$V_{(\text{sell})}$	SEL logic low voltage	$V_{\text{IN}} = 2.7\text{ V to }6\text{ V}$			0.4	V
$R_{(\text{en})}$	SEL pulldown resistor		300	700		k $\Omega$
$T_{\text{off}}$	SEL pulse width to disable	SELx high to low	40			ms
$K_{\text{ss}}$	IFB soft start current steps			16		
$T_{\text{ss}}$	Soft start time step	Measured as clock divider		64		
$T_{\text{ss\_en}}$	Soft start enable time	Time between falling and rising of two adjacent SELx pulses	40			ms
<b>CURRENT FEEDBACK</b>						
$V_{(\text{ISET})}$	ISET pin voltage		1.204	1.229	1.254	V
$K_{(\text{ISET})}$	Current multiplier	$I_{\text{OUT}}/I_{\text{SET}}$	820	900	990	
$K_M$	Current matching	In reference to the average of two output current	-6%		6%	
$V_{(\text{IFB})}$	IFB regulation voltage		300	330	360	mV
$V_{(\text{IFB\_L})}$	IFB low threshold hysteresis			60		mV
$T_{\text{Isink}}$	Current sink settle time measured from SELx rising edge <sup>(1)</sup>				6	$\mu\text{s}$
$I_{\text{Ikg}}$	IFB pin leakage current	IFB voltage = 25 V			1	$\mu\text{A}$
<b>POWER SWITCH AND DIODE</b>						
$r_{\text{DS(on)}}$	N-channel MOSFET on-resistance	$V_{\text{IN}} = V_{\text{GS}} = 3.6\text{ V}$		0.6	0.9	$\Omega$
$I_{(\text{LN\_NFET})}$	N-channel leakage current	$V_{\text{DS}} = 25\text{ V}$			1	$\mu\text{A}$
$V_F$	Power diode forward voltage	$I_D = 0.7\text{ A}$		0.83	1	V
<b>OC AND OVP</b>						
$I_{\text{LIM}}$	N-Channel MOSFET current limit	Dual output, $I_{\text{OUT}} = 15\text{ V}$ , $D = 76\%$	0.75	1	1.25	A
		Single output, $I_{\text{OUT}} = 15\text{ V}$ , $D = 76\%$	0.40	0.55	0.7	
$I_{(\text{IFB\_MAX})}$	Current sink max output current	$I_{\text{FB}} = 330\text{ mV}$	35			mA
$V_{\text{OVP}}$	Overvoltage threshold	TPS61150	27	28	29	V
		TPS61151	21	22	23	
$V_{\text{OVP(hys)}}$	Overvoltage hysteresis	TPS61150		550		mV
		TPS61151		440		
<b>PWM AND PFM CONTROL</b>						
$f_S$	Oscillator frequency		1	1.2	1.5	MHz
$D_{\text{max}}$	Maximum duty cycle	$V_{\text{FB}} = 1\text{ V}$	90%	93%		
<b>THERMAL SHUTDOWN</b>						
$T_{\text{shutdown}}$	Thermal shutdown threshold			160		$^\circ\text{C}$
$T_{\text{hys}}$	Thermal shutdown threshold hysteresis			15		$^\circ\text{C}$

(1) This specification determines the minimum on time required for PWM dimming for desirable linearity. The maximum PWM dimming frequency can be calculated from the minimum duty cycle required in the application.

### 7.6 Typical Characteristics

Data for all characteristic graphs were taken using the *Typical Application* with inductor = 10  $\mu$ H (VLCF4018T-100MR74-2), R1 = R2 = 56 k $\Omega$ , unless otherwise noted.

Table 3. Table Of Graphs

		FIGURE
Overcurrent limit	$V_{IN}$ = 3 V, 3.6 V, and 4 V, Single and dual output	Figure 1, Figure 2
K value over current	$V_{IN}$ = 3.6 V, $I_{LOAD}$ = 2 mA to 25 mA	Figure 3
PWM dimming linearity	Frequency = 20 kHz and 30 kHz	Figure 4
Single output PWM dimming waveform		Figure 5
Multiplexed PWM dimming waveform		Figure 6
Start-up waveform		Figure 7

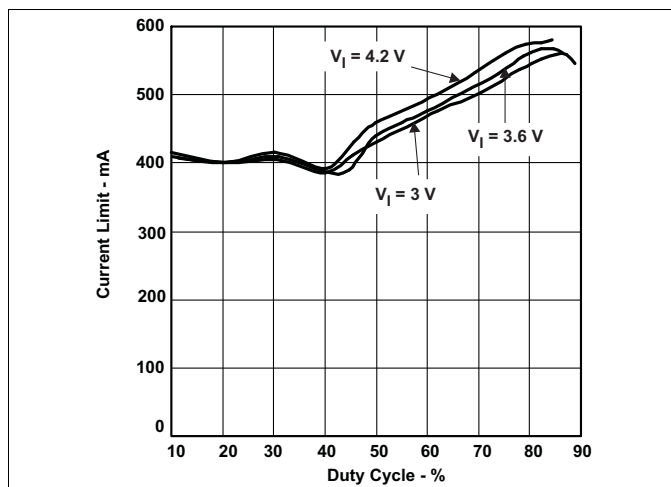

Figure 1. Overcurrent Limit (Single Output) vs Duty Cycle

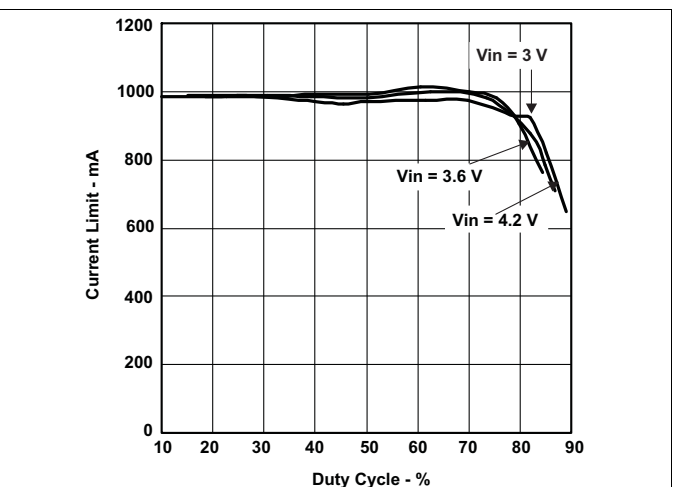

Figure 2. Overcurrent Limit (Dual Output) vs Duty Cycle

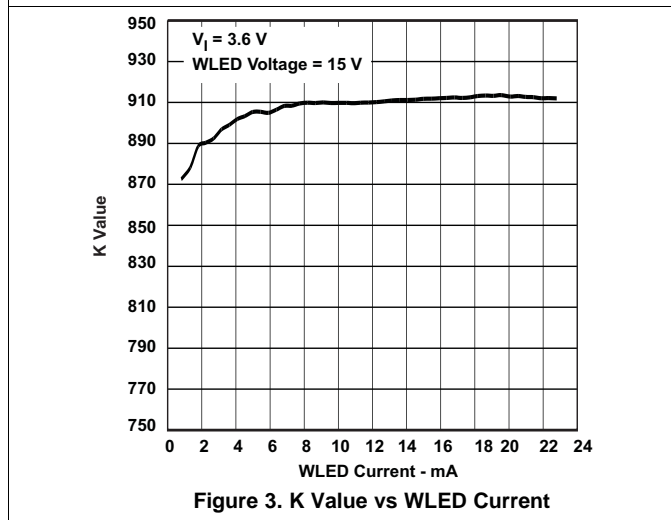

Figure 3. K Value vs WLED Current

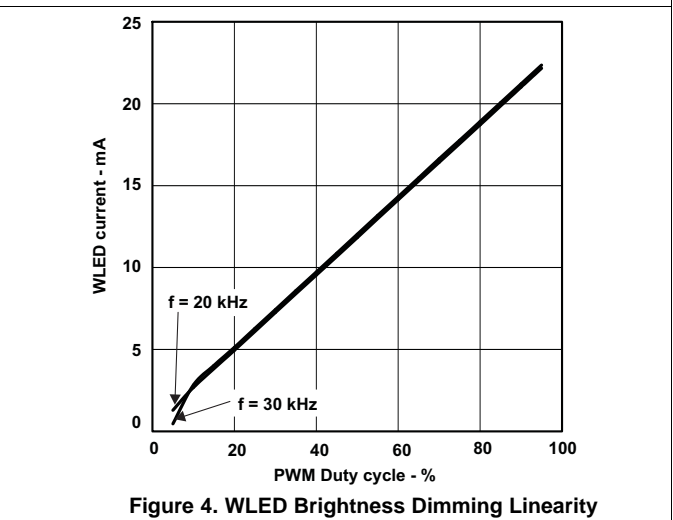

Figure 4. WLED Brightness Dimming Linearity

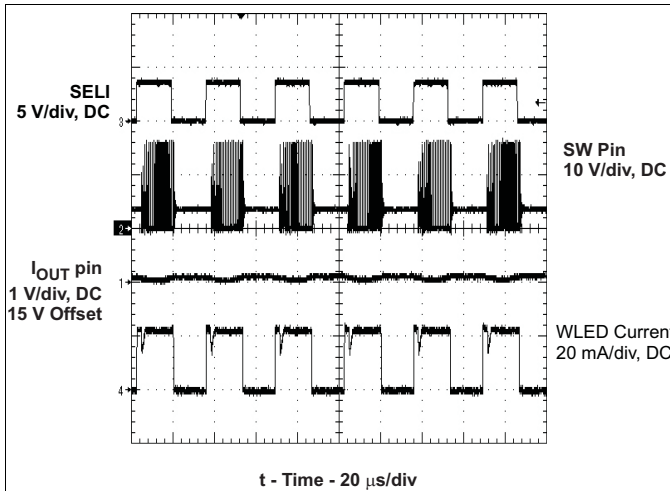

Figure 5. Single Output WLED PWM Brightness Dimming

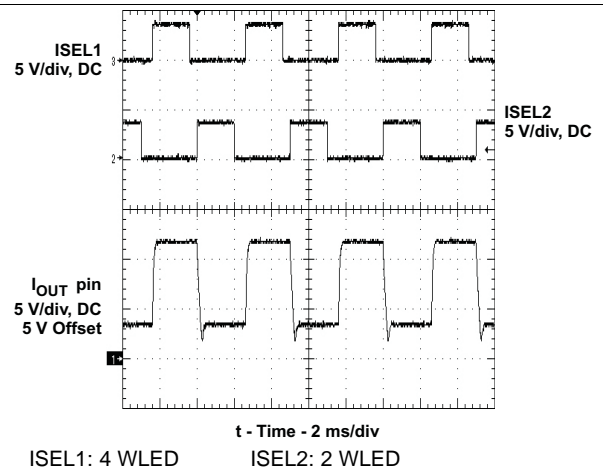

Figure 6. Multiplexed PWM Dimming

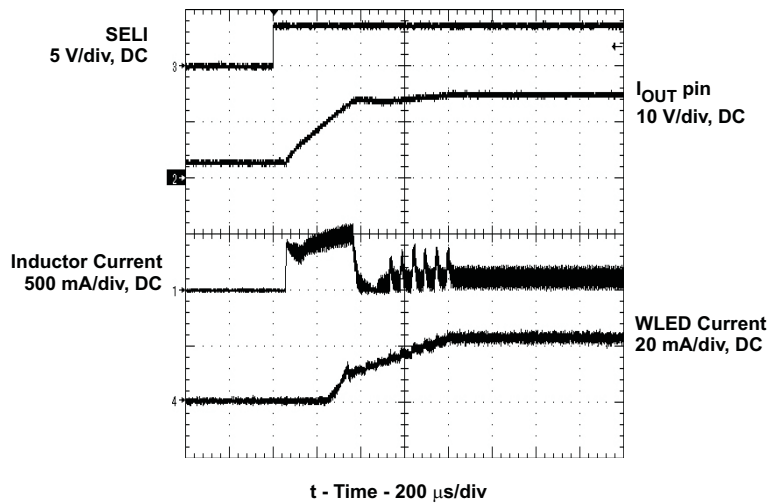

Figure 7. WLED Start-Up

## 8 Detailed Description

### 8.1 Overview

The TPS6115x is a two-channel WLED driver with an integrated inductive boost converter. The boost converter generates the bias voltage for the LED string while the two integrated low-side current sinks independently regulate the current in LED strings from  $V_{IN}$  to 29 V. Independent LED string dimming is provided via a PWM input at the SEL1 and SEL2 inputs.

### 8.2 Functional Block Diagram

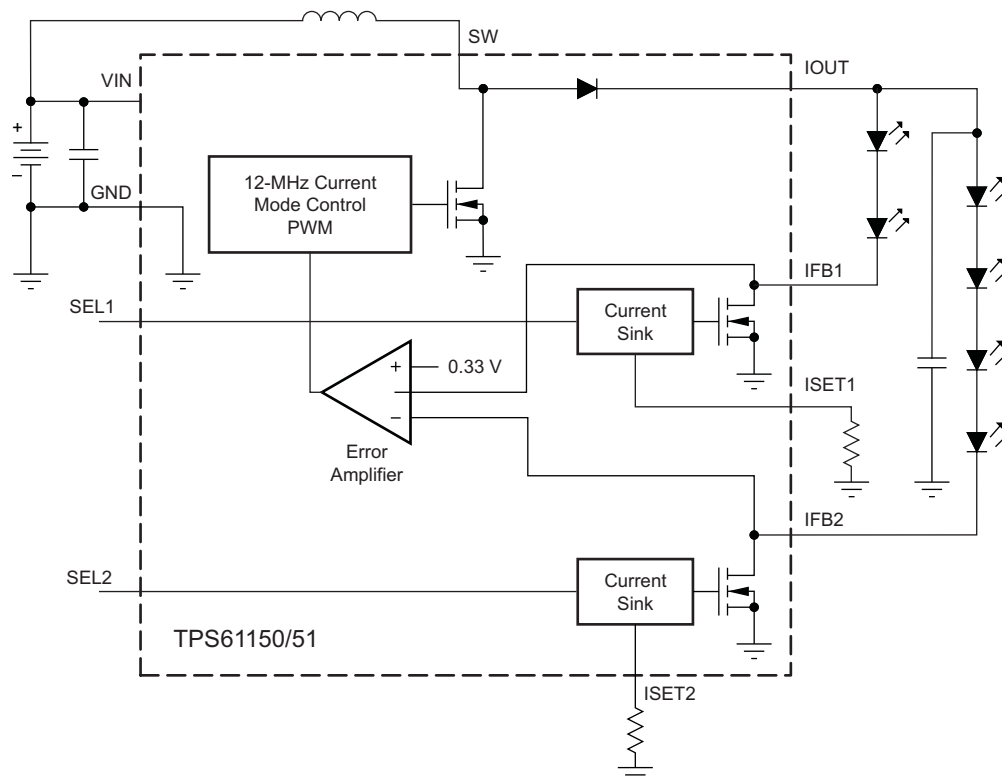

### 8.3 Feature Description

#### 8.3.1 Start-Up

During start-up, both the boost converter and the current sink circuitry ramp up simultaneously to establish a steady state. The current sink circuitry ramps up current in 16 steps with each step taking 64 clock cycles. This period ensures that the current sink loop is slower than the boost converter response during start-up. Therefore, the boost converter output comes up slowly as current sink circuitry ramps up the current. This configuration ensures a smooth start-up and minimizes in-rush current.

#### 8.3.2 Overvoltage Protection (OVP)

To prevent the boost output runaway as the result of WLED disconnection, there is an overvoltage protection circuit that stops the boost converter from switching as soon as its output exceeds the OVP threshold. When the voltage falls below the OVP threshold, the converter resumes switching.

The two OVP options offer the choices to prevent a 25-V rated output capacitor or the internal 30-V FET from breaking down.

## Feature Description (continued)

### 8.3.3 Undervoltage Lockout

An undervoltage lockout prevents device malfunction at input voltages below 1.65 V (typical). When the input voltage is below the undervoltage threshold, the device remains off, and both the boost converter and current sink circuit are turned off, providing isolation between input and output.

### 8.3.4 Thermal Shutdown

An internal thermal shutdown turns off the device when the typical junction temperature of 160°C is exceeded. The thermal shutdown has a hysteresis of typically 15°C.

### 8.3.5 Enable

Pulling either the SEL1 or SEL2 pin low turns off the corresponding output. If both SEL1 and SEL2 are low for more than 40 ms, the device shuts down and consumes less than 1 µA current. The SEL pin can also be used for PWM brightness dimming. To improve PWM dimming linearity, soft start is disabled if the time from the falling and rising edges of two adjacent SELx pulses is less than 40 ms. See the [Application and Implementation](#) section for details.

Each SEL input pin has an internal pulldown resistor to disable the device when the pin is floating.

## 8.4 Device Functional Modes

### 8.4.1 Current Regulation

The TPS6115x uses a single boost regulator to drive two WLED strings, each with independently programmable current. The boost converter adopts PWM control which is ideal for high output current and low output ripple noises. The feedback loop regulates the IFB pins to a threshold voltage (330 mV typical), giving the current sink circuit just enough headroom to operate.

The regulation current is set by the resistor on the ISET pin based on [Equation 1](#).

$$I_O = \frac{V_{ISET}}{R_{SET}} \times K_{ISET}$$

Where:

- $I_O$  = output current
- $V_{ISET}$  = ISET pin voltage (1.229 V typical)
- $R_{SET}$  = ISET pin resistor value
- $K_{ISET}$  = current multiplier (900 typical)

(1)

When both outputs are enabled, the boost converter provides enough power to provide the demanded current through IFB1 and IFB2 while keeping the voltage at IOUT high enough to meet the forward voltage drops of the WLEDs. Specifically, at start-up, the boost converter increases its output power, and therefore the output voltage, from  $I_{OUT}$  until IFB1 reaches its regulated voltage. Once IFB1 is within regulation, the device looks to the IFB2 voltage and may increase  $V_{(IOUT)}$  further to get IFB2 in regulation. After both IFB pins reach regulation, the feedback path dynamically switches to whichever IFB pin drops more than the IFB low hysteresis voltage (60 mV typical) below its regulation voltage. This architecture ensures proper current regulation for both IFB1 pins; however, the voltage at one IFB pin is higher than the minimum required regulation voltage. The overall efficiency when both strings are on depends on the voltage difference between the IFB1 and IFB2 pins. A large difference reduces the efficiency as a result of power losses across the current sink circuit of the IFB pin with the higher drop.

## 9 Application and Implementation

### NOTE

Information in the following applications sections is not part of the TI component specification, and TI does not warrant its accuracy or completeness. TI's customers are responsible for determining suitability of components for their purposes. Customers should validate and test their design implementation to confirm system functionality.

### 9.1 Application Information

The standard application circuit is shown in [Figure 8](#). Typical  $V_{IN}$  range is from a single cell Li+ battery. LED strings voltages can be as high as 28 V (TPS61150) or 22 V (TPS61151). LED string voltage mismatch is allowed due to the adaptive feedback headroom voltage which dynamically looks for and regulates the highest voltage string.

### 9.2 Typical Application

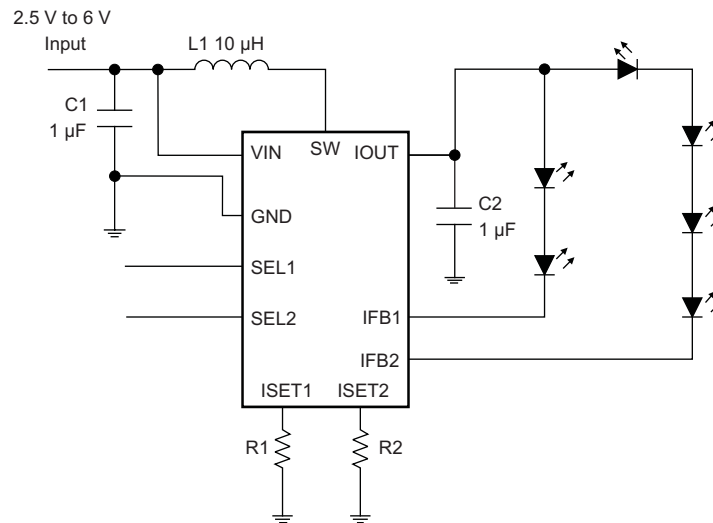

**Figure 8. TPS6115x Typical Application**

#### 9.2.1 Design Requirements

For typical dual output boost WLED driver applications, use the parameters listed in [Table 4](#).

**Table 4. Design Parameters**

DESIGN PARAMETER	EXAMPLE VALUE
Minimum input voltage	2.5 V
Minimum output voltage	$V_{IN}$
Output current	up to 35 mA/string
Fixed switching frequency	1.2 MHz

## 9.2.2 Detailed Design Procedure

### 9.2.2.1 Maximum Output Current

The overcurrent limit in a boost converter limits the maximum input current (and thus the maximum input power) for a given input voltage. Maximum output power is less than the maximum input power because of power conversion losses. Therefore, the current limit, input voltage, output voltage, and efficiency can all change maximum current output. Because current limit clamps peak inductor current, ripple must be subtracted to derive the maximum DC current. The ripple current is a function of switching frequency, inductor value, and duty cycle. Equation 2 and Equation 3 take all of the above factors into account for maximum output current calculation.

$$I_P = \frac{1}{\left[ L \times \left( \frac{1}{V_{IOUT} + V_F - V_{IN}} + \frac{1}{V_{IN}} \right) \times F_S \right]}$$

Where:

- $I_P$  = inductor peak to peak ripple
- $L$  = inductor value
- $V_F$  = power diode forward voltage
- $F_S$  = switching frequency
- $V_{IOUT}$  = boost output voltage. It is equal to 330 mV + voltage drop across WLED. (2)

$$I_{OUT\_MAX} = \frac{V_{IN} \times \left( I_{LIM} - \frac{I_P}{2} \right) \times \eta}{V_{IOUT}}$$

Where:

- $I_{OUT\_MAX}$  = maximum output current of the boost converter
- $I_{LIM}$  = overcurrent limit
- $\eta$  = efficiency (3)

To keep a tight range on the overcurrent limit, the TPS6115x uses the VIN and IOU pin voltages to compensate for the overcurrent limit variation caused by the slope compensation. However, the current threshold still has a residual dependency on the VIN and IOU voltages. Use Figure 1 and Figure 2 to identify the typical overcurrent limit in a specific application, and use a  $\pm 25\%$  tolerance to account for temperature dependency and process variations.

The maximum output current can also be limited by the current capability of the current-sink circuitry. It is designed to provide a maximum 35-mA current regardless of the current capability of the boost converter.

### 9.2.2.2 WLED Brightness Dimming

There are three ways to change the output current *on the fly* for WLED dimming. The first method parallels an additional resistor with the ISET pin resistor as shown in Figure 9. The switch (Q1) can change the ISET pin resistance, and therefore modify the output current. This method is very simple, but can provide only limited dimming steps.

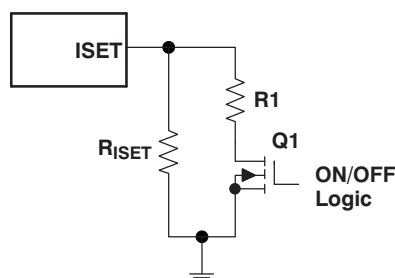

Figure 9. Switching In or Out With an Additional Resistor to Change Output Current

Alternatively, a PWM dimming signal at the SEL pin can modulate the output current by the duty cycle of the signal. The logic high of the signal turns on the current sink circuit, while the logic low turns it off. This operation creates an averaged DC output current proportional to the duty cycle of the PWM signal. The frequency of the PWM signal must be high enough to avoid flashing of the WLEDs. The soft start of the current sink circuit is disabled during the PWM dimming to improve linearity.

The major concern of the PWM dimming is the creation of audible noises that can come from the inductor or output capacitor of the boost converter, or both. The audible noises on the output capacitor are created by the presence of voltage ripple in range of audible frequencies. The TPS6115x alleviates the problem by disconnecting the WLEDs from the output capacitor when the SEL pin is low. Therefore, the output capacitor is not discharged by the WLEDs, and thus reduces the voltage ripple during PWM dimming.

The audible noises can be eliminated by using a PWM dimming frequency above or below the audible frequency range. The maximum PWM dimming frequency of the TPS6115x is determined by the current settling time ( $T_{ISINK}$ ), which is the time required for the sink circuit to reach a steady state after the SEL pin transitions from low to high. The maximum dimming frequency can be calculated by Equation 4:

$$F_{PWM\_MAX} = \frac{D_{MIN}}{T_{ISINK}}$$

Where:

- $D_{MIN}$  = min duty cycle of the PWM dimming required in the application (4)

For 20%  $D_{MIN}$ , a PWM dimming frequency up to 33 kHz is possible, putting the noise frequency above the audible range.

Because the TPS61150/1 dynamically regulates one IFB pin voltage, its output voltage can have a large ripple during PWM dimming as shown in Figure 6. This ripple may cause ceramic output capacitors to ring audibly. To reduce the output ripple, the configurations shown in Figure 16 and Figure 17 are recommended for PWM dimming. In Figure 16, both current strings have the same number of LEDs and the same PWM signal. In Figure 17, one string (in this case, string 2) is not PWM dimmed and has a greater total forward voltage drop than string 1, either because of having more LEDs than string 1 or because of adding a resistor in series with string 2. Therefore, IFB2 controls the regulation regardless of the PWM signal on IFB1, and the output ripple is significantly reduced when string 1 is dimmed. The circuit in Figure 17 could have been reconfigured with string 1 having the larger total forward drop.

The third method uses an external DC voltage and resistor as shown in Figure 10 to change the ISET pin current, and thus control the output current. The DC voltage can be the output of a filtered PWM signal. The formulas to calculate the output current is given by Equation 5 and Equation 6.

$$I_{WLED} = K_{ISET} \times \left( \frac{1.229}{R_{ISET}} + \frac{1.229 - V_{DC}}{R_1} \right) \text{ for DC voltage input} \quad (5)$$

$$I_{WLED} = K_{ISET} \times \left( \frac{1.229}{R_{ISET}} + \frac{1.229 - V_{DC}}{R_1 + 10K} \right) \text{ for PWM signal input}$$

Where:

- $K_{ISET}$  = current multiplier between the ISET pin current and the IFB pin current.
- $V_{DC}$  = voltage of the DC voltage source or the DC voltage of the PWM signal. (6)



**Figure 10. Analog Dimming Using an External Voltage Source to Control the Output Current**

### 9.2.2.3 Inductor Selection

Because the selection of the inductor affects the power supply steady-state operation, transient behavior, and loop stability, the inductor is the key component in power regulator design. Three specifications are the most important to the performance of the inductor: the inductor value, DC resistance (DCR), and saturation current. Considering the inductor value alone is not enough.

The inductor inductance value determines the inductor ripple current. It is generally recommended to set peak-to-peak ripple current given by Equation 2 to between 30% to 40% of DC current. It is a good compromise of power loss and inductor size. For this reason, 10- $\mu$ H inductors are recommended for the TPS6115x. Inductor DC current can be calculated as Equation 7.

$$I_{L\_DC} = \frac{V_{IOUT} \times I_{OUT}}{V_{IN} \times \eta} \quad (7)$$

Use the maximum load current and minimum  $V_{in}$  for calculation.

The internal loop compensation for PWM control is optimized for the external component shown in the Figure 8 with consideration of component tolerance. Inductor values can have  $\pm 20\%$  tolerance with no current bias. When the inductor current approaches saturation level, its inductance can decrease 20% to 35% from the 0-A value, depending on how the inductor vendor defines saturation. Using an inductor with a smaller inductance value forces discontinuous PWM in which the inductor current ramps down to zero before the end of each switching cycle, reduces the boost converter maximum output current, and causes large input voltage ripple. An inductor with larger inductance reduces the gain and phase margin of the feedback loop, possibly resulting in instability.

Regulator efficiency depends on the resistance of its high current path and switching losses associated with the PWM switch and power diode. Although the TPS6115x has optimized the internal switches, the overall efficiency still relies on inductor DCR; lower DCR improves efficiency. However, there is a trade-off between DCR and inductor size, and shielded inductors typically have higher DCR than unshielded ones. A DCR in range of 150 m $\Omega$  to 350 m $\Omega$  is suitable for applications that require *both on* mode. A DCR in the range of 250 m $\Omega$  to 450 m $\Omega$  is a good choice for single output applications. Table 5 and Table 6 list some recommended inductor models.

**Table 5. Recommended Inductors for Single Output**

	L ( $\mu$ H)	DCR TYPICAL(m $\Omega$ )	I <sub>SAT</sub> (A)	SIZE (L x W x H mm)
<b>TDK</b>				
VLF3012AT-100MR49	10	360	0.49	2.8 x 3 x 1.2
VLCF4018T-100MR74-2	10	163	0.74	4 x 4 x 1.8
<b>Sumida</b>				
CDRH2D11/HP	10	447	0.52	3.2 x 3.2 x 1.2
CDRH3D16/HP	10	230	0.84	4 x 4 x 1.8

**Table 6. Recommended Inductors for Dual Output**

	L ( $\mu$ H)	DCR TYPICAL (m $\Omega$ )	I <sub>SAT</sub> (A)	SIZE (L x W x H mm)
<b>TDK</b>				
VLCF4018T-100MR74-2	10	163	0.74	4 x 4 x 1.8
VLF4012AT-100MR79	10	300	0.85	3.5 x 3.7 x 1.2
<b>Sumida</b>				
CDRH3D16/HP	10	230	0.84	4 x 4 x 1.8
CDRH4D11/HP	10	340	0.85	4.8 x 4.8 x 1.2

### 9.2.2.4 Input and Output Capacitor Selection

The output capacitor is primarily selected for the output ripple of the converter. This ripple voltage is the sum of the ripple caused by the capacitor capacitance and its equivalent series resistance (ESR). Assuming a capacitor with zero ESR, the minimum capacitance needed for a given ripple can be calculated by Equation 8.

$$C_{OUT} = \frac{(V_{IOUT} - V_{IN})I_{OUT}}{V_{IOUT} \times F_S \times V_{RIPPLE}}$$

Where:

- $V_{\text{RIPPLE}}$  = peak-to-peak output ripple (8)

For  $V_{\text{IN}} = 3.6 \text{ V}$ ,  $V_{\text{OUT}} = 20 \text{ V}$ , and  $F_{\text{S}} = 1.2 \text{ MHz}$ , 0.1% ripple (20 mV) would require a 1- $\mu\text{F}$  capacitor. For this value, ceramic capacitors are the best choice for size, cost, and availability.

The additional output ripple component caused by ESR is calculated using [Equation 9](#):

$$V_{\text{ripple\_ESR}} = I_{\text{out}} \times R_{\text{ESR}} \quad (9)$$

As a result of its low ESR,  $V_{\text{ripple\_ESR}}$  can be neglected for ceramic capacitors, but must be considered if tantalum or electrolytic capacitors are used.

During a load transient, the capacitor at the output of the boost converter must supply or absorb additional current before the inductor current ramps up the steady-state value. Larger capacitors always help to reduce the voltage over- and undershoot during a load transient. A larger capacitor also helps loop stability.

Care must be taken when evaluating ceramic capacitor derating because of the applied DC voltage, aging, and frequency response. For example, larger form-factor capacitors (in size 1206) have self-resonant frequencies in the range of the TPS6115x switching frequency. Therefore, the effective capacitance is significantly lower for these capacitors. As a result, it may be necessary to use small capacitors in parallel instead of one large capacitor.

[Table 7](#) lists some recommended input and output ceramic capacitors. Two popular vendors for high-value ceramic capacitors are:

TDK (<http://www.component.tdk.com/components.php>)

Murata (<http://www.murata.com/cap/index.html>)

**Table 7. Recommended Input and Output Capacitors**

	CAPACITANCE ( $\mu\text{F}$ )	VOLTAGE (V)	CASE
<b>TDK</b>			
C3216X5R1E475K	4.7	25	1206
C2012X5R1E105K	1	25	0805
C1005X5R0J105K	1	6.3	0402
<b>Murata</b>			
GRM319R61E475KA12D	4.7	25	1206
GRM216R61E105KA12D	1	25	0805
GRM155R60J105KE19D	1	6.3	0402

9.2.3 Application Curves

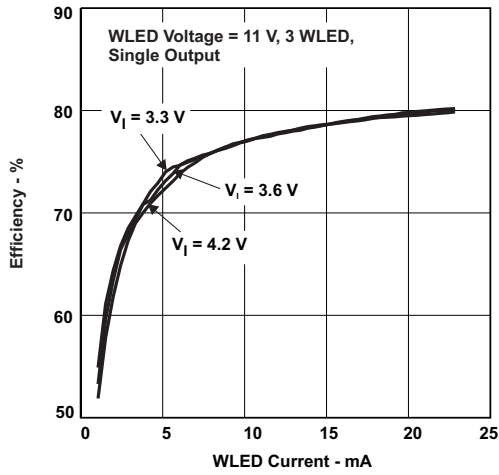

Figure 11. Efficiency vs Load Current

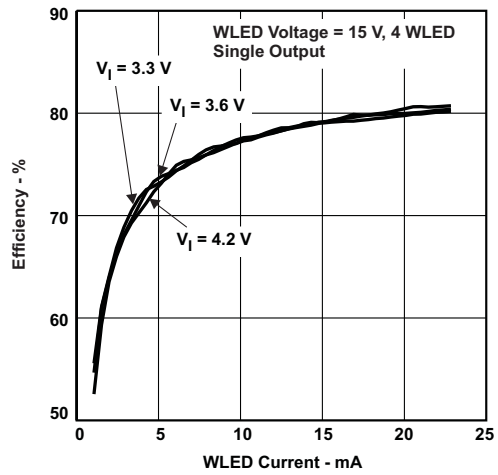

Figure 12. Efficiency vs Load Current

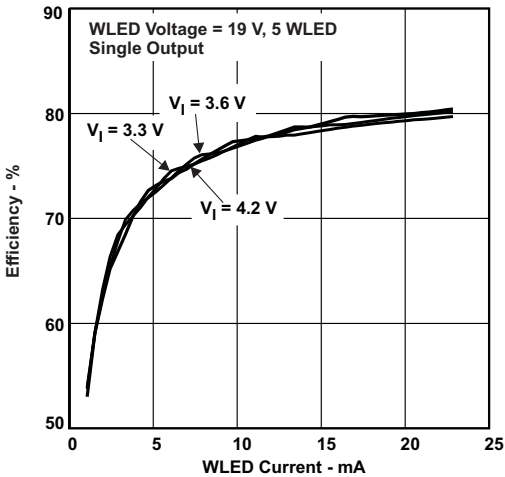

Figure 13. Efficiency vs Load Current

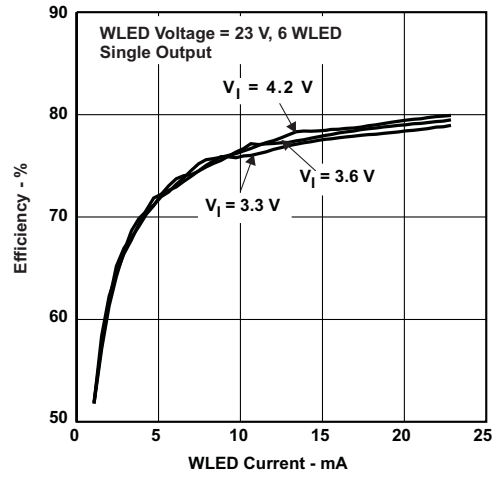

Figure 14. Efficiency vs Load Current

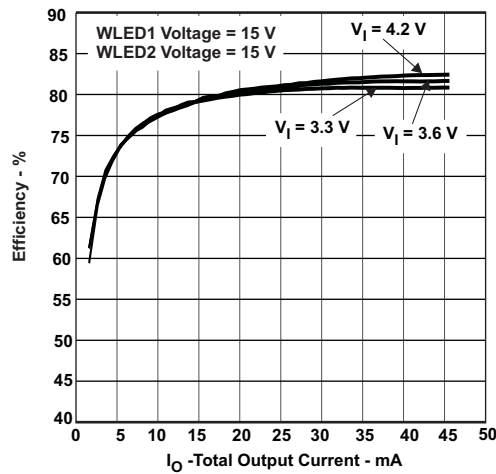

Figure 15. Both on Efficiency vs Total Output Current

### 9.3 Additional Application Circuits

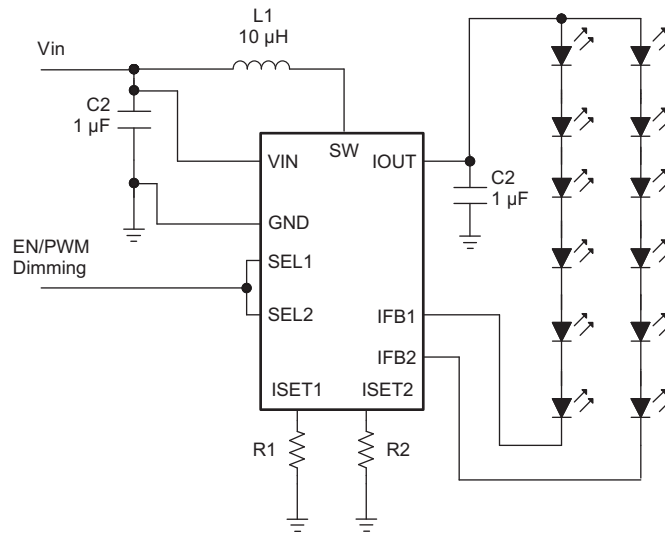

Figure 16. Driving up to 12 WLEDs With One LCD Backlight

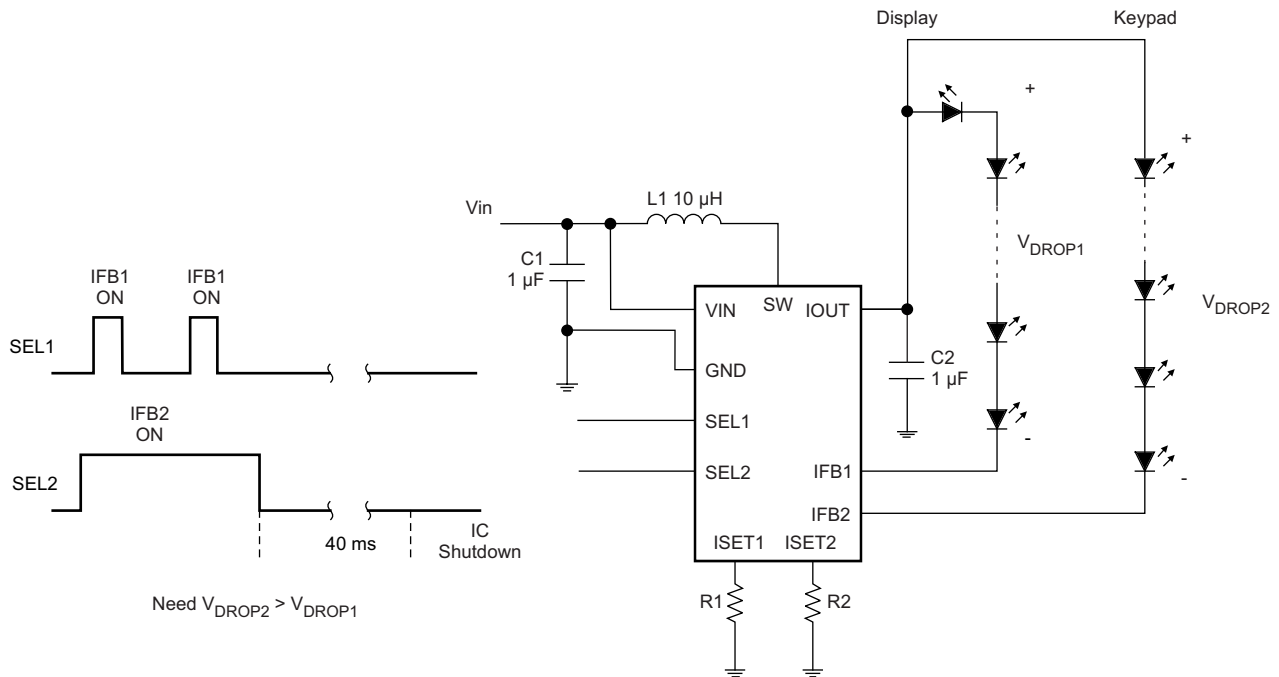

Figure 17. Driving A Keypad and LCD Backlight, Applying PWM Signal to the SEL1 Pin

## 10 Power Supply Recommendations

Apply an input voltage between 2.5 V and 6 V. Bypass IN with a ceramic capacitor as close to the VIN pin and GND pin as possible in order to filter switching noise.

## 11 Layout

### 11.1 Layout Guidelines

As for all switching power supplies, especially those providing high current and using high switching frequencies, printed circuit board (PCB) layout is an important design step. If layout is not carefully done, the regulator could show instability as well as electromagnetic interference (EMI) problems. Therefore, use wide and short traces for high current paths. The input capacitor must not only be close to the VIN pin, but also to the GND pin in order to reduce the input ripple seen by the device. The VIN and SW pins are conveniently located on the edges of the device; therefore, the inductor can be placed close to the device. The output capacitor must be placed near the load to minimize ripple and maximize transient performance.

It is also beneficial to have the ground of the output capacitor close to the GND pin because there will be a large ground return current flowing between these two connections. When laying out the signal ground, use short traces separated from power ground traces, and connect them together at a single point on the PCB.

### 11.2 Layout Example

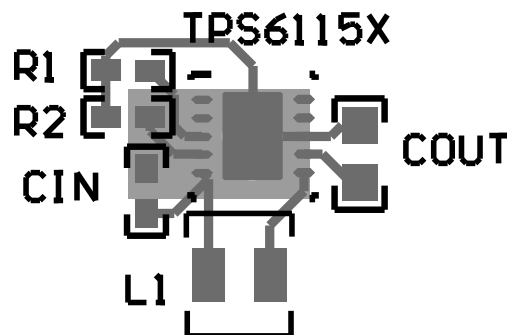

Figure 18. TPS61150 Layout Example

## 12 Device and Documentation Support

### 12.1 Device Support

#### 12.1.1 Third-Party Products Disclaimer

TI'S PUBLICATION OF INFORMATION REGARDING THIRD-PARTY PRODUCTS OR SERVICES DOES NOT CONSTITUTE AN ENDORSEMENT REGARDING THE SUITABILITY OF SUCH PRODUCTS OR SERVICES OR A WARRANTY, REPRESENTATION OR ENDORSEMENT OF SUCH PRODUCTS OR SERVICES, EITHER ALONE OR IN COMBINATION WITH ANY TI PRODUCT OR SERVICE.

### 12.2 Related Links

[Table 8](#) lists quick access links. Categories include technical documents, support and community resources, tools and software, and quick access to sample or buy.

**Table 8. Related Links**

PARTS	PRODUCT FOLDER	SAMPLE & BUY	TECHNICAL DOCUMENTS	TOOLS & SOFTWARE	SUPPORT & COMMUNITY
TPS61150	<a href="#">Click here</a>	<a href="#">Click here</a>	<a href="#">Click here</a>	<a href="#">Click here</a>	<a href="#">Click here</a>
TPS61151	<a href="#">Click here</a>	<a href="#">Click here</a>	<a href="#">Click here</a>	<a href="#">Click here</a>	<a href="#">Click here</a>

### 12.3 Community Resources

The following links connect to TI community resources. Linked contents are provided "AS IS" by the respective contributors. They do not constitute TI specifications and do not necessarily reflect TI's views; see TI's [Terms of Use](#).

**TI E2E™ Online Community** *TI's Engineer-to-Engineer (E2E) Community*. Created to foster collaboration among engineers. At [e2e.ti.com](http://e2e.ti.com), you can ask questions, share knowledge, explore ideas and help solve problems with fellow engineers.

**Design Support** *TI's Design Support* Quickly find helpful E2E forums along with design support tools and contact information for technical support.

### 12.4 Trademarks

E2E is a trademark of Texas Instruments.  
All other trademarks are the property of their respective owners.

### 12.5 Electrostatic Discharge Caution



These devices have limited built-in ESD protection. The leads should be shorted together or the device placed in conductive foam during storage or handling to prevent electrostatic damage to the MOS gates.

### 12.6 Glossary

[SLYZ022](#) — *TI Glossary*.

This glossary lists and explains terms, acronyms, and definitions.

## 13 Mechanical, Packaging, and Orderable Information

The following pages include mechanical, packaging, and orderable information. This information is the most current data available for the designated devices. This data is subject to change without notice and revision of this document. For browser-based versions of this data sheet, refer to the left-hand navigation.

**PACKAGING INFORMATION**

Orderable Device	Status (1)	Package Type	Package Drawing	Pins	Package Qty	Eco Plan (2)	Lead/Ball Finish (6)	MSL Peak Temp (3)	Op Temp (°C)	Device Marking (4/5)	Samples
TPS61150DRCR	ACTIVE	VSON	DRC	10	3000	Green (RoHS & no Sb/Br)	CU NIPDAU	Level-2-260C-1 YEAR	-40 to 85	BCQ	<a href="#">Samples</a>
TPS61150DRCRG4	ACTIVE	VSON	DRC	10	3000	Green (RoHS & no Sb/Br)	CU NIPDAU	Level-2-260C-1 YEAR	-40 to 85	BCQ	<a href="#">Samples</a>
TPS61150DRCT	ACTIVE	VSON	DRC	10	250	Green (RoHS & no Sb/Br)	CU NIPDAU	Level-2-260C-1 YEAR		BCQ	<a href="#">Samples</a>
TPS61151DRCR	ACTIVE	VSON	DRC	10	3000	Green (RoHS & no Sb/Br)	CU NIPDAU	Level-2-260C-1 YEAR	-40 to 85	BRH	<a href="#">Samples</a>
TPS61151DRCRG4	ACTIVE	VSON	DRC	10	3000	Green (RoHS & no Sb/Br)	CU NIPDAU	Level-2-260C-1 YEAR	-40 to 85	BRH	<a href="#">Samples</a>
TPS61151DRCT	ACTIVE	VSON	DRC	10	250	Green (RoHS & no Sb/Br)	CU NIPDAU	Level-2-260C-1 YEAR	-40 to 85	BRH	<a href="#">Samples</a>

(1) The marketing status values are defined as follows:

**ACTIVE:** Product device recommended for new designs.

**LIFEBUY:** TI has announced that the device will be discontinued, and a lifetime-buy period is in effect.

**NRND:** Not recommended for new designs. Device is in production to support existing customers, but TI does not recommend using this part in a new design.

**PREVIEW:** Device has been announced but is not in production. Samples may or may not be available.

**OBSOLETE:** TI has discontinued the production of the device.

(2) **RoHS:** TI defines "RoHS" to mean semiconductor products that are compliant with the current EU RoHS requirements for all 10 RoHS substances, including the requirement that RoHS substance do not exceed 0.1% by weight in homogeneous materials. Where designed to be soldered at high temperatures, "RoHS" products are suitable for use in specified lead-free processes. TI may reference these types of products as "Pb-Free".

**RoHS Exempt:** TI defines "RoHS Exempt" to mean products that contain lead but are compliant with EU RoHS pursuant to a specific EU RoHS exemption.

**Green:** TI defines "Green" to mean the content of Chlorine (Cl) and Bromine (Br) based flame retardants meet JS709B low halogen requirements of <=1000ppm threshold. Antimony trioxide based flame retardants must also meet the <=1000ppm threshold requirement.

(3) MSL, Peak Temp. - The Moisture Sensitivity Level rating according to the JEDEC industry standard classifications, and peak solder temperature.

(4) There may be additional marking, which relates to the logo, the lot trace code information, or the environmental category on the device.

(5) Multiple Device Markings will be inside parentheses. Only one Device Marking contained in parentheses and separated by a "~" will appear on a device. If a line is indented then it is a continuation of the previous line and the two combined represent the entire Device Marking for that device.

<sup>(6)</sup> Lead/Ball Finish - Orderable Devices may have multiple material finish options. Finish options are separated by a vertical ruled line. Lead/Ball Finish values may wrap to two lines if the finish value exceeds the maximum column width.

**Important Information and Disclaimer:**The information provided on this page represents TI's knowledge and belief as of the date that it is provided. TI bases its knowledge and belief on information provided by third parties, and makes no representation or warranty as to the accuracy of such information. Efforts are underway to better integrate information from third parties. TI has taken and continues to take reasonable steps to provide representative and accurate information but may not have conducted destructive testing or chemical analysis on incoming materials and chemicals. TI and TI suppliers consider certain information to be proprietary, and thus CAS numbers and other limited information may not be available for release.

In no event shall TI's liability arising out of such information exceed the total purchase price of the TI part(s) at issue in this document sold by TI to Customer on an annual basis.

**TAPE AND REEL INFORMATION**

**QUADRANT ASSIGNMENTS FOR PIN 1 ORIENTATION IN TAPE**

\*All dimensions are nominal

Device	Package Type	Package Drawing	Pins	SPQ	Reel Diameter (mm)	Reel Width W1 (mm)	A0 (mm)	B0 (mm)	K0 (mm)	P1 (mm)	W (mm)	Pin1 Quadrant
TPS61150DRCR	VSON	DRC	10	3000	330.0	12.4	3.3	3.3	1.1	8.0	12.0	Q2
TPS61150DRCT	VSON	DRC	10	250	180.0	12.4	3.3	3.3	1.1	8.0	12.0	Q2
TPS61151DRCR	VSON	DRC	10	3000	330.0	12.4	3.3	3.3	1.1	8.0	12.0	Q2
TPS61151DRCT	VSON	DRC	10	250	180.0	12.4	3.3	3.3	1.1	8.0	12.0	Q2

**TAPE AND REEL BOX DIMENSIONS**

\*All dimensions are nominal

Device	Package Type	Package Drawing	Pins	SPQ	Length (mm)	Width (mm)	Height (mm)
TPS61150DRCR	VSON	DRC	10	3000	367.0	367.0	35.0
TPS61150DRCT	VSON	DRC	10	250	210.0	185.0	35.0
TPS61151DRCR	VSON	DRC	10	3000	367.0	367.0	35.0
TPS61151DRCT	VSON	DRC	10	250	210.0	185.0	35.0

## GENERIC PACKAGE VIEW

DRC 10

VSON - 1 mm max height

PLASTIC SMALL OUTLINE - NO LEAD

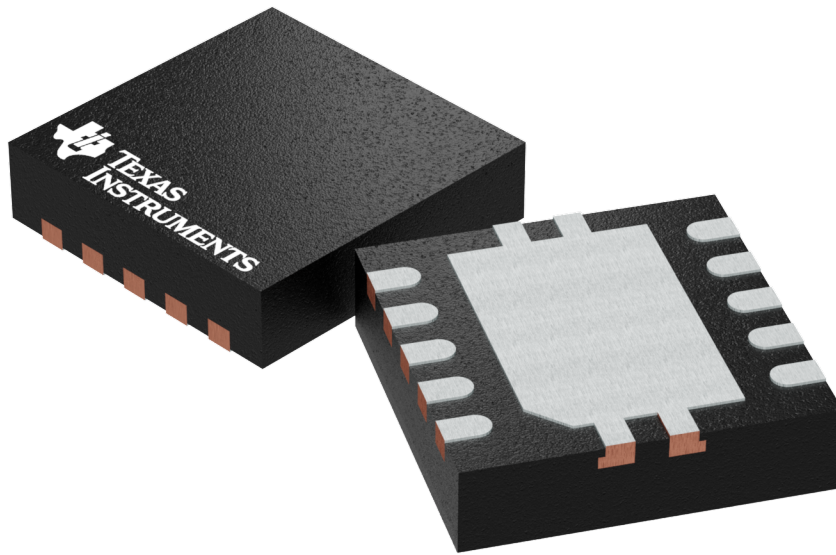

Images above are just a representation of the package family, actual package may vary.  
Refer to the product data sheet for package details.

4204102-3/M



# EXAMPLE BOARD LAYOUT

DRC0010J

VSON - 1 mm max height

PLASTIC SMALL OUTLINE - NO LEAD

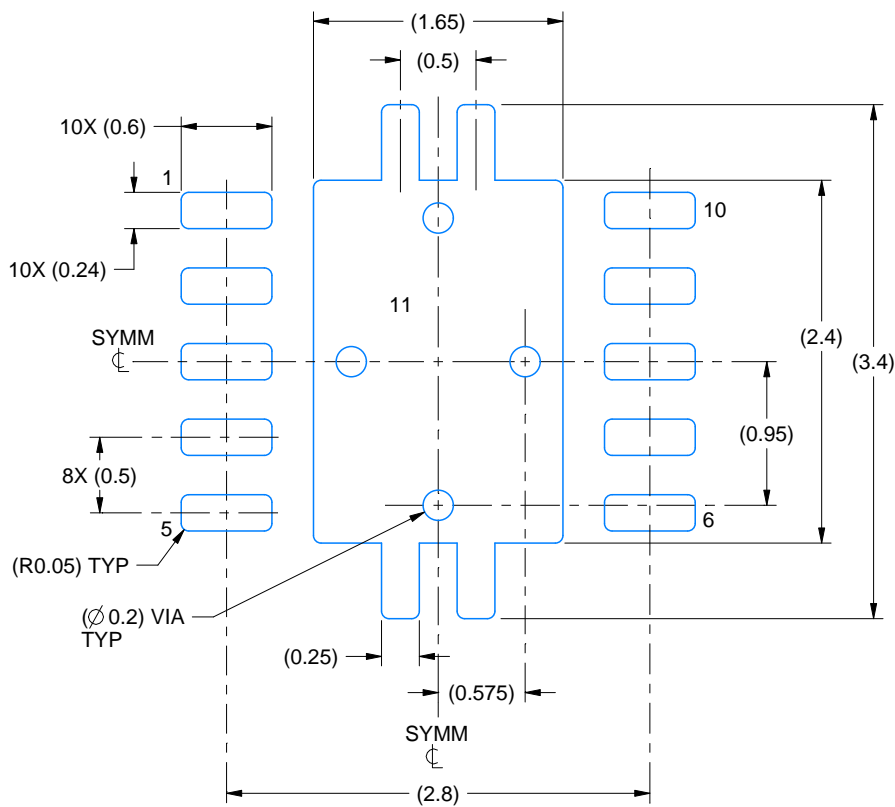

LAND PATTERN EXAMPLE  
EXPOSED METAL SHOWN  
SCALE:20X

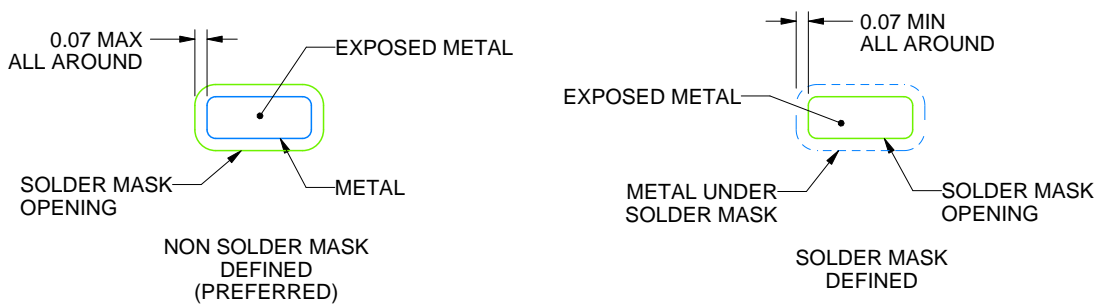

SOLDER MASK DETAILS

4218878/B 07/2018

NOTES: (continued)

4. This package is designed to be soldered to a thermal pad on the board. For more information, see Texas Instruments literature number SLUA271 ([www.ti.com/lit/slua271](http://www.ti.com/lit/slua271)).
5. Vias are optional depending on application, refer to device data sheet. If any vias are implemented, refer to their locations shown on this view. It is recommended that vias under paste be filled, plugged or tented.

# EXAMPLE STENCIL DESIGN

DRC0010J

VSON - 1 mm max height

PLASTIC SMALL OUTLINE - NO LEAD

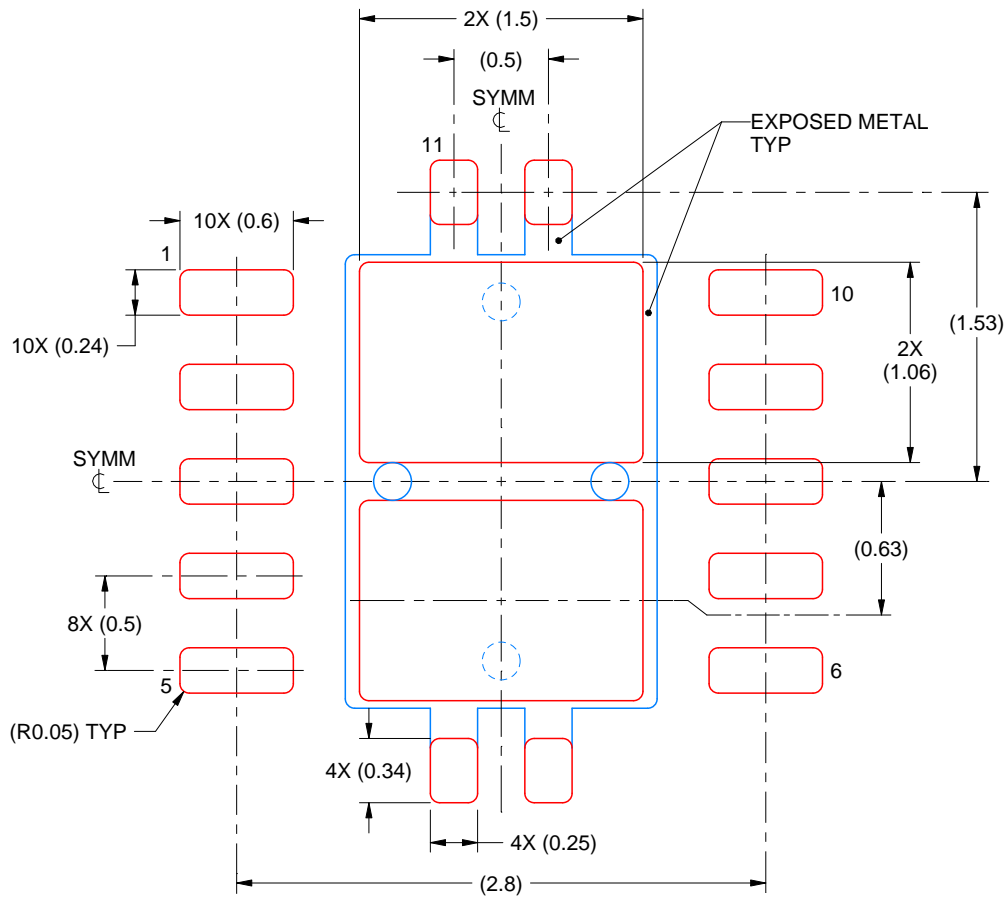

SOLDER PASTE EXAMPLE  
BASED ON 0.125 mm THICK STENCIL

EXPOSED PAD 11:  
80% PRINTED SOLDER COVERAGE BY AREA  
SCALE:25X

4218878/B 07/2018

NOTES: (continued)

6. Laser cutting apertures with trapezoidal walls and rounded corners may offer better paste release. IPC-7525 may have alternate design recommendations.

## IMPORTANT NOTICE

Texas Instruments Incorporated (TI) reserves the right to make corrections, enhancements, improvements and other changes to its semiconductor products and services per JESD46, latest issue, and to discontinue any product or service per JESD48, latest issue. Buyers should obtain the latest relevant information before placing orders and should verify that such information is current and complete.

TI's published terms of sale for semiconductor products (<http://www.ti.com/sc/docs/stdterms.htm>) apply to the sale of packaged integrated circuit products that TI has qualified and released to market. Additional terms may apply to the use or sale of other types of TI products and services.

Reproduction of significant portions of TI information in TI data sheets is permissible only if reproduction is without alteration and is accompanied by all associated warranties, conditions, limitations, and notices. TI is not responsible or liable for such reproduced documentation. Information of third parties may be subject to additional restrictions. Resale of TI products or services with statements different from or beyond the parameters stated by TI for that product or service voids all express and any implied warranties for the associated TI product or service and is an unfair and deceptive business practice. TI is not responsible or liable for any such statements.

Buyers and others who are developing systems that incorporate TI products (collectively, "Designers") understand and agree that Designers remain responsible for using their independent analysis, evaluation and judgment in designing their applications and that Designers have full and exclusive responsibility to assure the safety of Designers' applications and compliance of their applications (and of all TI products used in or for Designers' applications) with all applicable regulations, laws and other applicable requirements. Designer represents that, with respect to their applications, Designer has all the necessary expertise to create and implement safeguards that (1) anticipate dangerous consequences of failures, (2) monitor failures and their consequences, and (3) lessen the likelihood of failures that might cause harm and take appropriate actions. Designer agrees that prior to using or distributing any applications that include TI products, Designer will thoroughly test such applications and the functionality of such TI products as used in such applications.

TI's provision of technical, application or other design advice, quality characterization, reliability data or other services or information, including, but not limited to, reference designs and materials relating to evaluation modules, (collectively, "TI Resources") are intended to assist designers who are developing applications that incorporate TI products; by downloading, accessing or using TI Resources in any way, Designer (individually or, if Designer is acting on behalf of a company, Designer's company) agrees to use any particular TI Resource solely for this purpose and subject to the terms of this Notice.

TI's provision of TI Resources does not expand or otherwise alter TI's applicable published warranties or warranty disclaimers for TI products, and no additional obligations or liabilities arise from TI providing such TI Resources. TI reserves the right to make corrections, enhancements, improvements and other changes to its TI Resources. TI has not conducted any testing other than that specifically described in the published documentation for a particular TI Resource.

Designer is authorized to use, copy and modify any individual TI Resource only in connection with the development of applications that include the TI product(s) identified in such TI Resource. NO OTHER LICENSE, EXPRESS OR IMPLIED, BY ESTOPPEL OR OTHERWISE TO ANY OTHER TI INTELLECTUAL PROPERTY RIGHT, AND NO LICENSE TO ANY TECHNOLOGY OR INTELLECTUAL PROPERTY RIGHT OF TI OR ANY THIRD PARTY IS GRANTED HEREIN, including but not limited to any patent right, copyright, mask work right, or other intellectual property right relating to any combination, machine, or process in which TI products or services are used. Information regarding or referencing third-party products or services does not constitute a license to use such products or services, or a warranty or endorsement thereof. Use of TI Resources may require a license from a third party under the patents or other intellectual property of the third party, or a license from TI under the patents or other intellectual property of TI.

TI RESOURCES ARE PROVIDED "AS IS" AND WITH ALL FAULTS. TI DISCLAIMS ALL OTHER WARRANTIES OR REPRESENTATIONS, EXPRESS OR IMPLIED, REGARDING RESOURCES OR USE THEREOF, INCLUDING BUT NOT LIMITED TO ACCURACY OR COMPLETENESS, TITLE, ANY EPIDEMIC FAILURE WARRANTY AND ANY IMPLIED WARRANTIES OF MERCHANTABILITY, FITNESS FOR A PARTICULAR PURPOSE, AND NON-INFRINGEMENT OF ANY THIRD PARTY INTELLECTUAL PROPERTY RIGHTS. TI SHALL NOT BE LIABLE FOR AND SHALL NOT DEFEND OR INDEMNIFY DESIGNER AGAINST ANY CLAIM, INCLUDING BUT NOT LIMITED TO ANY INFRINGEMENT CLAIM THAT RELATES TO OR IS BASED ON ANY COMBINATION OF PRODUCTS EVEN IF DESCRIBED IN TI RESOURCES OR OTHERWISE. IN NO EVENT SHALL TI BE LIABLE FOR ANY ACTUAL, DIRECT, SPECIAL, COLLATERAL, INDIRECT, PUNITIVE, INCIDENTAL, CONSEQUENTIAL OR EXEMPLARY DAMAGES IN CONNECTION WITH OR ARISING OUT OF TI RESOURCES OR USE THEREOF, AND REGARDLESS OF WHETHER TI HAS BEEN ADVISED OF THE POSSIBILITY OF SUCH DAMAGES.

Unless TI has explicitly designated an individual product as meeting the requirements of a particular industry standard (e.g., ISO/TS 16949 and ISO 26262), TI is not responsible for any failure to meet such industry standard requirements.

Where TI specifically promotes products as facilitating functional safety or as compliant with industry functional safety standards, such products are intended to help enable customers to design and create their own applications that meet applicable functional safety standards and requirements. Using products in an application does not by itself establish any safety features in the application. Designers must ensure compliance with safety-related requirements and standards applicable to their applications. Designer may not use any TI products in life-critical medical equipment unless authorized officers of the parties have executed a special contract specifically governing such use. Life-critical medical equipment is medical equipment where failure of such equipment would cause serious bodily injury or death (e.g., life support, pacemakers, defibrillators, heart pumps, neurostimulators, and implantables). Such equipment includes, without limitation, all medical devices identified by the U.S. Food and Drug Administration as Class III devices and equivalent classifications outside the U.S.

TI may expressly designate certain products as completing a particular qualification (e.g., Q100, Military Grade, or Enhanced Product). Designers agree that it has the necessary expertise to select the product with the appropriate qualification designation for their applications and that proper product selection is at Designers' own risk. Designers are solely responsible for compliance with all legal and regulatory requirements in connection with such selection.

Designer will fully indemnify TI and its representatives against any damages, costs, losses, and/or liabilities arising out of Designer's non-compliance with the terms and provisions of this Notice.

## Looking for pricing, stock, or lifecycle information?

Click below to explore more details on WIN SOURCE:

 [View TPS61150DRCR](#) on WIN SOURCE

 [Texas Instruments](#) Information

## Optimize Your Supply Chain with WIN SOURCE Solutions

-  Global Sourcing Solution
-  Obsolete Management
-  Cost Control Management
-  Shortage Management
-  Alternative Solution
-  Excess Inventory Management