



**THE DATASHEET OF
TPS3828-33QDBVRQ1**



TPS382x-xx-Q1 Voltage Monitor With Watchdog Timer

1 Features

- Qualified for Automotive Applications
- AEC-Q100 Qualified With the Following Results:
 - Device Temperature Grade 1: -40°C to 125°C
 - Device HBM ESD Classification Level 2
 - Device CDM ESD Classification Level C4B
- ESD Protection Exceeds 2000 V Per MIL-STD-883, Method 3015; Using Human Body Model ($C = 100\text{ pF}$, $R = 1500\ \Omega$)
- Power-On Reset Generator With Fixed Delay Time of 200 ms (TPS3823/4/5/8-xx-Q1) or 25 ms (TPS3820-xx-Q1)
- Manual Reset Input (TPS3820/3/5/8-xx-Q1)
- Reset Output Available in Active-Low (TPS3820/3/4/5-xx-Q1), Active-High (TPS3824/5-xx-Q1), and Open Drain (TPS3828-xx-Q1)
- Supply Voltage Supervision Range: 2.5 V, 3 V, 3.3 V, 5 V
- Watchdog Timer (TPS3820/3/4/8-xx-Q1)
- Supply Current of 15 μA (Typical)
- 5-Pin SOT-23 Package
- Temperature Range: -40°C to 125°C

2 Applications

- Automotive DSPs, Microcontrollers, or Microprocessors
- Industrial Equipment
- Programmable Controls
- Automotive Systems
- Portable and Battery-Powered Equipment
- Intelligent Instruments
- Wireless Communications Systems

Typical Application Schematic

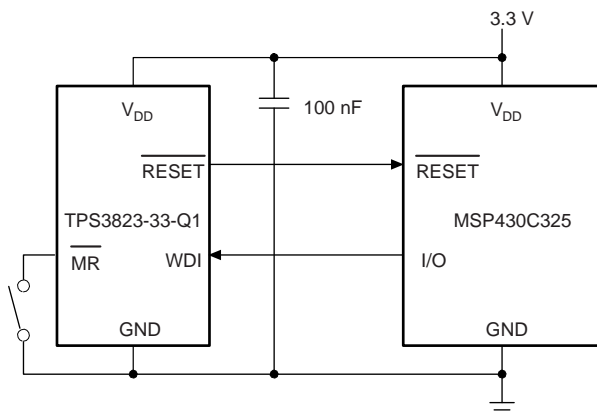

3 Description

The TPS382x-xx-Q1 family of supervisors provide circuit initialization and timing supervision, primarily for DSP and processor-based systems. During power on, $\overline{\text{RESET}}$ asserts when the supply voltage V_{DD} becomes greater than 1.1 V. Thereafter, the supply voltage supervisor monitors V_{DD} and keeps $\overline{\text{RESET}}$ active low as long as V_{DD} remains below the threshold voltage, $V_{\text{IT-}}$. An internal timer delays the return of the output to the inactive state (high) to ensure proper system reset. The delay time, t_{d} , starts after V_{DD} has risen above the threshold voltage $V_{\text{IT-}}$. When the supply voltage drops below the threshold voltage $V_{\text{IT-}}$, the output becomes active (low) again. No external components are required. All the devices of this family have a fixed-sense threshold voltage, $V_{\text{IT-}}$, set by an internal voltage divider. The TPS382x-xx-Q1 family also offers watchdog time out options of 200 ms (TPS3820-xx-Q1) and 1.6 s (TPS3823/4/8-xx-Q1).

Device Information⁽¹⁾

PART NUMBER	PACKAGE	BODY SIZE (NOM)
TPS382x-xx-Q1	SOT-23 (5)	2.90 mm x 1.60 mm

(1) For all available packages, see the orderable addendum at the end of the datasheet.

Normalized Input Threshold Voltage vs Free-Air Temperature

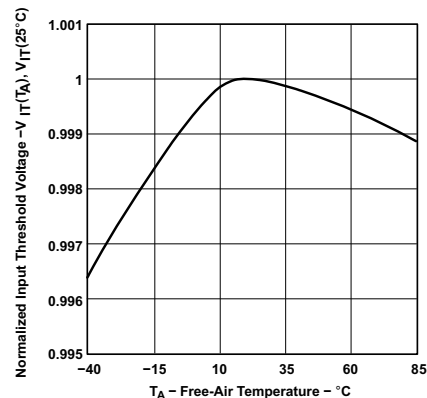

Table of Contents

1 Features	1	8.3 Feature Description.....	9
2 Applications	1	8.4 Device Functional Modes.....	10
3 Description	1	9 Application and Implementation	11
4 Revision History	2	9.1 Application Information.....	11
5 Device Comparison Table	3	9.2 Typical Applications	11
6 Pin Configuration and Functions	3	10 Power Supply Recommendations	12
7 Specifications	4	11 Layout	13
7.1 Absolute Maximum Ratings	4	11.1 Layout Guidelines	13
7.2 ESD Ratings.....	4	11.2 Layout Example	13
7.3 Recommended Operating Conditions.....	4	12 Device and Documentation Support	14
7.4 Thermal Information	4	12.1 Device Support.....	14
7.5 Electrical Characteristics.....	5	12.2 Documentation Support	14
7.6 Timing Requirements	6	12.3 Community Resources.....	14
7.7 Switching Characteristics	6	12.4 Trademarks	14
7.8 Typical Characteristics	7	12.5 Electrostatic Discharge Caution.....	15
8 Detailed Description	9	12.6 Glossary	15
8.1 Overview	9	13 Mechanical, Packaging, and Orderable	15
8.2 Functional Block Diagram	9	Information	15

4 Revision History

NOTE: Page numbers for previous revisions may differ from page numbers in the current version.

Changes from Revision B (June 2008) to Revision C	Page
• Added ESD Ratings table, Feature Description section, Device Functional Modes, Application and Implementation section, Power Supply Recommendations section, Layout section, Device and Documentation Support section, and Mechanical, Packaging, and Orderable Information section	1
• Added AEC-Q100 Qualified information and Temperature Range to Features	1
• Added -Q1 to all applicable part numbers	1
• Added FIXED DELAY TIME column to table	3

5 Device Comparison Table

DEVICE	RESET	$\overline{\text{RESET}}$	WDI	$\overline{\text{MR}}$	FIXED DELAY TIME
TPS3820-xx-Q1		Push-pull	X	X	25 ms
TPS3823-xx-Q1		Push-pull	X	X	200 ms
TPS3824-xx-Q1	Push-pull		X		200 ms
TPS3825-xx-Q1	Push-pull	Push-pull		X	200 ms
TPS3828-xx-Q1		Open-drain	X	X	200 ms

6 Pin Configuration and Functions

TPS3820-xx-Q1, TPS3823-xx-Q1, TPS3828-xx-Q1: DBV PACKAGE
5-Pin SOT-23
Top View

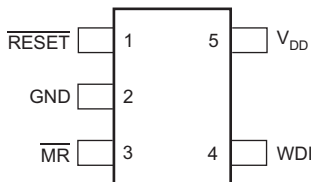

TPS3824-xx-Q1: DBV PACKAGE
5-Pin SOT-23
Top View

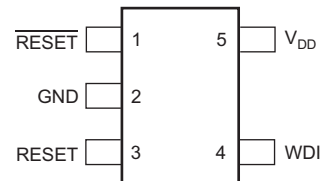

TPS3825-xx-Q1: DBV PACKAGE
5-Pin SOT-23
Top View

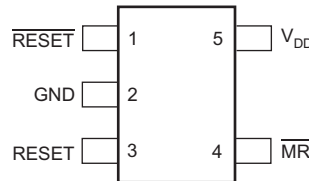

Pin Functions

NAME	PIN			I/O	DESCRIPTION
	TPS3820-xx-Q1, TPS3823-xx-Q1, TPS3828-xx-Q1	TPS3824-xx-Q1	TPS3825-xx-Q1		
GND	2	2	2	—	Ground connection
$\overline{\text{MR}}$	3	—	4	I	Manual-reset input. Pull low to force a reset. RESET remains low <u>as</u> long as $\overline{\text{MR}}$ is low and for the time-out period after $\overline{\text{MR}}$ goes high. Leave unconnected or connect to V_{DD} when unused.
RESET	—	3	3	O	Active-high reset output. Either push-pull or open-drain output stage.
$\overline{\text{RESET}}$	1	1	1	O	Active-low reset output. Either push-pull or open-drain output stage.
V_{DD}	5	5	5	I	Supply voltage. Powers the device and monitors its own voltage.
WDI	4	4	—	I	Watchdog timer input. If WDI remains high or low longer than the time-out period, then reset is triggered. The timer clears when reset is asserted or when WDI sees a rising edge or a falling edge. If unused, the WDI connection must be high impedance to prevent it from causing a reset event.

7 Specifications

7.1 Absolute Maximum Ratings

over operating free-air temperature range (unless otherwise noted)⁽¹⁾⁽²⁾

		MIN	MAX	UNIT
Voltage	V _{DD}	-0.3	6	V
	RESET, $\overline{\text{RESET}}$, MR, WDI	-0.3	(V _{DD} + 0.3)	
Current	Maximum low output, I _{OL}	-5	5	mA
	Maximum high output, I _{OH}	-5	5	
	Output range (V _O < 0 or V _O > V _{DD}), I _{OK}	-10	10	
Continuous total power dissipation		See Thermal Information		
Temperature	Operating free-air, T _A	-40	125	°C
	Storage, T _{stg}	-65	150	

- (1) Stresses beyond those listed under *Absolute Maximum Ratings* may cause permanent damage to the device. These are stress ratings only, which do not imply functional operation of the device at these or any other conditions beyond those indicated under *Recommended Operating Conditions*. Exposure to absolute-maximum-rated conditions for extended periods may affect device reliability.
- (2) All voltage values are with respect to GND.

7.2 ESD Ratings

		VALUE	UNIT
V _(ESD)	Electrostatic discharge	Human-body model (HBM), per AEC Q100-002 ⁽¹⁾	±2000
		Charged-device model (CDM), per AEC Q100-011	±750

- (1) AEC Q100-002 indicates that HBM stressing shall be in accordance with the ANSI/ESDA/JEDEC JS-001 specification.

7.3 Recommended Operating Conditions

over operating junction temperature range (unless otherwise noted).

		MIN	NOM	MAX	UNIT
V _{DD}	Supply voltage	1.1		5.5	V
V _I	Input voltage	0		V _{DD} + 0.3	V
V _{IH}	High-level input voltage at $\overline{\text{MR}}$ and WDI	0.7 × V _{DD}			V
V _{IL}	Low-level input voltage			0.3 × V _{DD}	V
Δt/ΔV	Input transition rise and fall rate at $\overline{\text{MR}}$ or WDI			100	ns/V
T _A	Operating free-air temperature range	-40		125	°C

7.4 Thermal Information

THERMAL METRIC ⁽¹⁾		TPS382x-xx-Q1	UNIT
		DBV (SOT-23)	
		5 PINS	
R _{θJA}	Junction-to-ambient thermal resistance	209.1	°C/W
R _{θJC(top)}	Junction-to-case (top) thermal resistance	72.8	°C/W
R _{θJB}	Junction-to-board thermal resistance	36.7	°C/W
Ψ _{JT}	Junction-to-top characterization parameter	2.1	°C/W
Ψ _{JB}	Junction-to-board characterization parameter	35.8	°C/W

- (1) For more information about traditional and new thermal metrics, see the *Semiconductor and IC Package Thermal Metrics* application report, [SPRA953](#).

7.5 Electrical Characteristics

over operating junction temperature range (unless otherwise noted)

PARAMETER		TEST CONDITIONS		MIN	TYP	MAX	UNIT		
V_{OH}	$\overline{\text{RESET}}$	TPS382x-25-Q1	$V_{DD} = V_{IT-} + 0.2 \text{ V}$, $I_{OH} = -20 \mu\text{A}$	0.8 × V_{DD}			V		
		TPS382x-30-Q1	$V_{DD} = V_{IT-} + 0.2 \text{ V}$, $I_{OH} = -30 \mu\text{A}$						
		TPS382x-33-Q1	$V_{DD} = V_{IT-} + 0.2 \text{ V}$, $I_{OH} = -30 \mu\text{A}$						
	TPS382x-50-Q1	$V_{DD} = V_{IT-} + 0.2 \text{ V}$, $I_{OH} = -120 \mu\text{A}$	$V_{DD} - 1.5 \text{ V}$						
	RESET	TPS3824-25-Q1	$V_{DD} \geq 1.8 \text{ V}$, $I_{OH} = -100 \mu\text{A}$	0.8 × V_{DD}					
		TPS3825-25-Q1	$V_{DD} \geq 1.8 \text{ V}$, $I_{OH} = -100 \mu\text{A}$						
TPS3824-30-Q1 TPS3825-30-Q1		$V_{DD} \geq 1.8 \text{ V}$, $I_{OH} = -150 \mu\text{A}$							
V_{OL}	RESET	TPS3824-25-Q1	$V_{DD} = V_{IT-} + 0.2 \text{ V}$, $I_{OL} = 1 \text{ mA}$	0.4			V		
		TPS3825-25-Q1	$V_{DD} = V_{IT-} + 0.2 \text{ V}$, $I_{OL} = 1 \text{ mA}$						
		TPS3824-30-Q1 TPS3825-30-Q1	$V_{DD} = V_{IT-} + 0.2 \text{ V}$, $I_{OL} = 1.2 \text{ mA}$						
		TPS3824-33-Q1 TPS3825-33-Q1	$V_{DD} = V_{IT-} + 0.2 \text{ V}$, $I_{OL} = 1.2 \text{ mA}$						
	$\overline{\text{RESET}}$	TPS3824-50-Q1 TPS3825-50-Q1	$V_{DD} = V_{IT-} + 0.2 \text{ V}$, $I_{OL} = 3 \text{ mA}$	0.45					
		TPS382x-25-Q1	$V_{DD} = V_{IT-} - 0.2 \text{ V}$, $I_{OL} = 1 \text{ mA}$						
		TPS382x-30-Q1 TPS382x-33-Q1	$V_{DD} = V_{IT-} - 0.2 \text{ V}$, $I_{OL} = 1.2 \text{ mA}$						
	Power-up reset voltage ⁽¹⁾		TPS382x-50-Q1	$V_{DD} = V_{IT-} - 0.2 \text{ V}$, $I_{OL} = 3 \text{ mA}$					
				$V_{DD} \geq 1.1 \text{ V}$, $I_{OL} = 20 \mu\text{A}$				0.4	V
	V_{IT-}	Negative-going input threshold voltage ⁽²⁾	TPS382x-25-Q1	$T_A = 0^\circ\text{C}$ to 85°C	2.21	2.25		2.3	V
TPS382x-30-Q1			2.59		2.63	2.69			
TPS382x-33-Q1			2.88		2.93	3			
TPS382x-50-Q1			4.49		4.55	4.64			
TPS382x-25-Q1			$T_A = -40^\circ\text{C}$ to 125°C	2.19	2.25	2.3			
TPS382x-30-Q1				2.55	2.63	2.69			
TPS382x-33-Q1				2.84	2.93	3			
TPS382x-50-Q1				4.44	4.55	4.64			
V_{hys}	Hysteresis at V_{DD} input	TPS382x-25-Q1		30			mV		
		TPS382x-30-Q1							
		TPS382x-33-Q1							
		TPS382x-50-Q1						50	
$I_{IH(AV)}$	Average high-level input current	WDI	$WDI = V_{DD}$, time average (DC = 88%)	120			μA		
$I_{IL(AV)}$	Average low-level input current		$WDI = 0.3 \text{ V}$, $V_{DD} = 5.5 \text{ V}$ time average (DC = 12%)	-15					
I_{IH}	High-level input current	WDI	$WDI = V_{DD}$	140	190		μA		
		$\overline{\text{MR}}$	$\overline{\text{MR}} = V_{DD} \times 0.7$, $V_{DD} = 5.5 \text{ V}$	-40	-60				
I_{IL}	Low-level input current	WDI	$WDI = 0.3 \text{ V}$, $V_{DD} = 5.5 \text{ V}$	140	190		μA		
		$\overline{\text{MR}}$	$\overline{\text{MR}} = 0.3 \text{ V}$, $V_{DD} = 5.5 \text{ V}$	-110	-160				
I_{OS}	Output short-circuit current ⁽³⁾	$\overline{\text{RESET}}$	TPS382x-25-Q1	$V_{DD} = V_{IT, \text{max}} + 0.2 \text{ V}$, $V_O = 0 \text{ V}$			μA		
			TPS382x-30-Q1						
			TPS382x-33-Q1						
			TPS382x-50-Q1					-400	
						-800			
I_{DD}	Supply current	WDI, $\overline{\text{MR}}$, and outputs unconnected		15	25		μA		
		Internal pullup resistor at $\overline{\text{MR}}$		52			k Ω		
C_i	Input capacitance at $\overline{\text{MR}}$, WDI	$V_i = 0 \text{ V}$ to 5.5 V		5			pF		

(1) The lowest supply voltage at which $\overline{\text{RESET}}$ becomes active. t_r , $V_{DD} \geq 15 \mu\text{s/V}$.

(2) To ensure best stability of the threshold voltage, a bypass capacitor (ceramic, 0.1 μF) should be placed near the supply terminals.

(3) The RESET short-circuit current is the maximum pullup current when RESET is driven low by a microprocessor bidirectional reset pin.

7.6 Timing Requirements

At $R_L = 1\text{ M}\Omega$, $C_L = 50\text{ pF}$, and $T_J = 25^\circ\text{C}$, unless otherwise noted.

			MIN	TYP	MAX	UNIT
t_w	Pulse width	at V_{DD}	$V_{DD} = V_{IT-} + 0.2\text{ V}$, $V_{DD} = V_{IT-} - 0.2\text{ V}$	6		μs
		at $\overline{\text{MR}}$	$V_{DD} \geq V_{IT-} + 0.2\text{ V}$, $V_{IL} = 0.3 \times V_{DD}$, $V_{IH} = 0.7 \times V_{DD}$	1		μs
		at WDI	$V_{DD} \geq V_{IT-} + 0.2\text{ V}$, $V_{IL} = 0.3 \times V_{DD}$, $V_{IH} = 0.7 \times V_{DD}$	100		ns

7.7 Switching Characteristics

At $R_L = 1\text{ M}\Omega$, $C_L = 50\text{ pF}$, and $T_A = 25^\circ\text{C}$, unless otherwise noted.

PARAMETER		TEST CONDITIONS	MIN	TYP	MAX	UNIT	
t_{out}	Watchdog time out	TPS3820-xx-Q1	$V_{DD} \geq V_{IT-} + 0.2\text{ V}$	112	200	300	ms
		TPS3823/4/8-xx-Q1	See Figure 1	0.9	1.6	2.5	s
t_d	Delay time	TPS3820-xx-Q1	$V_{DD} \geq V_{IT-} + 0.2\text{ V}$	15	25	37	ms
		TPS3823/4/5/8-xx-Q1	See Figure 1	120	200	300	
t_{PHL}	Propagation (delay) time, high-to-low-level output	$\overline{\text{MR}}$ to $\overline{\text{RESET}}$ delay (TPS3820/3/5/8-xx-Q1)	$V_{DD} \geq V_{IT-} + 0.2\text{ V}$, $V_{IL} = 0.3 \times V_{DD}$, $V_{IH} = 0.7 \times V_{DD}$			0.1	μs
		V_{DD} to $\overline{\text{RESET}}$ delay	$V_{IL} = V_{IT-} - 0.2\text{ V}$, $V_{IH} = V_{IT-} + 0.2\text{ V}$			25	
t_{PLH}	Propagation (delay) time, low-to-high-level output	$\overline{\text{MR}}$ to RESET delay (TPS3824/5-xx-Q1)	$V_{DD} \geq V_{IT-} + 0.2\text{ V}$, $V_{IL} = 0.3 \times V_{DD}$, $V_{IH} = 0.7 \times V_{DD}$			0.1	μs
		V_{DD} to RESET delay (TPS3824/5-xx-Q1)	$V_{IL} = V_{IT-} - 0.2\text{ V}$, $V_{IH} = V_{IT-} + 0.2\text{ V}$			25	

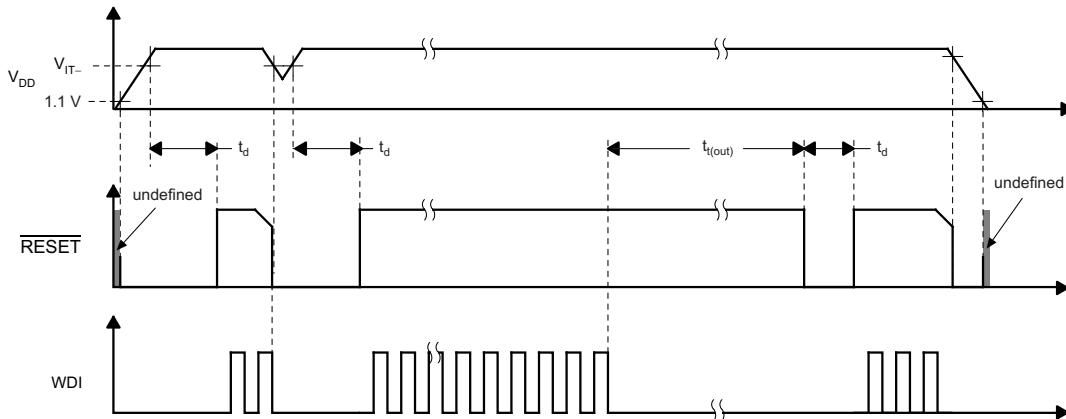

Figure 1. Delay and Time Out Timing Diagram

7.8 Typical Characteristics

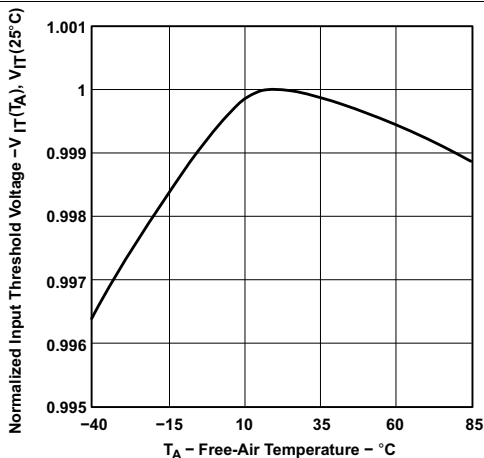

Figure 2. Normalized Input Threshold Voltage vs Free-Air Temperature at V_{DD}

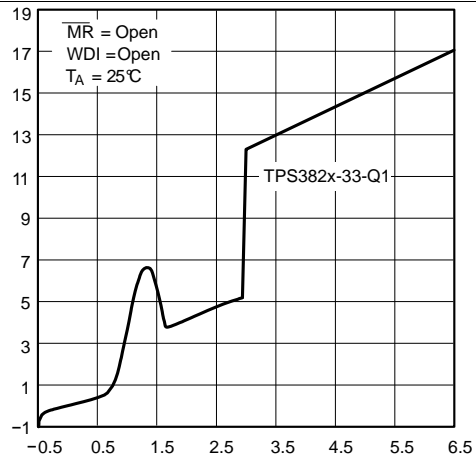

Figure 3. Supply Current vs Supply Voltage

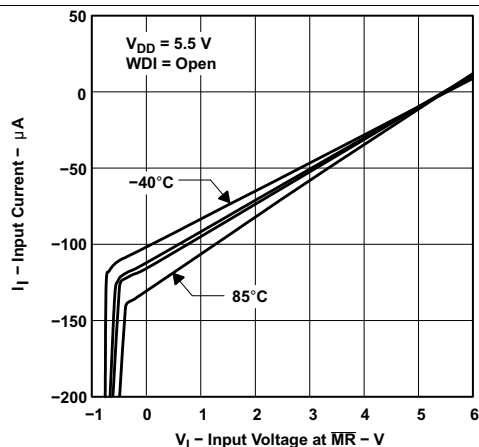

Figure 4. Input Current vs Input Voltage at \overline{MR}

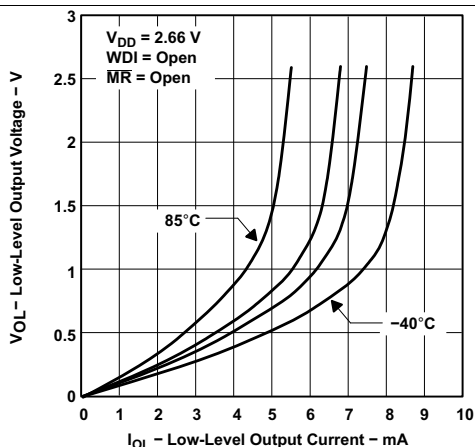

Figure 5. Low-Level Output Voltage vs Low-Level Output Current

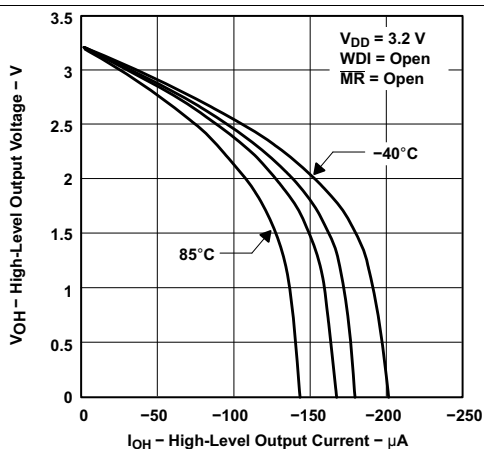

Figure 6. High-Level Output Voltage vs High-Level Output Current

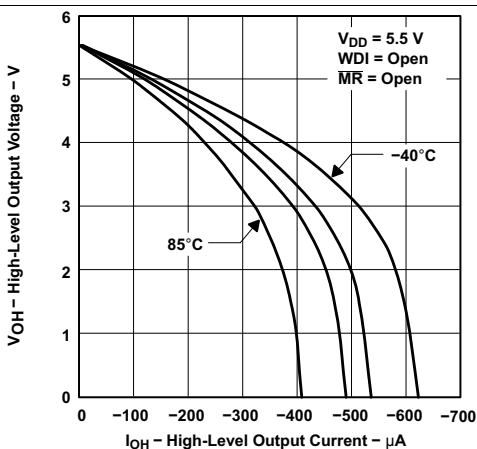
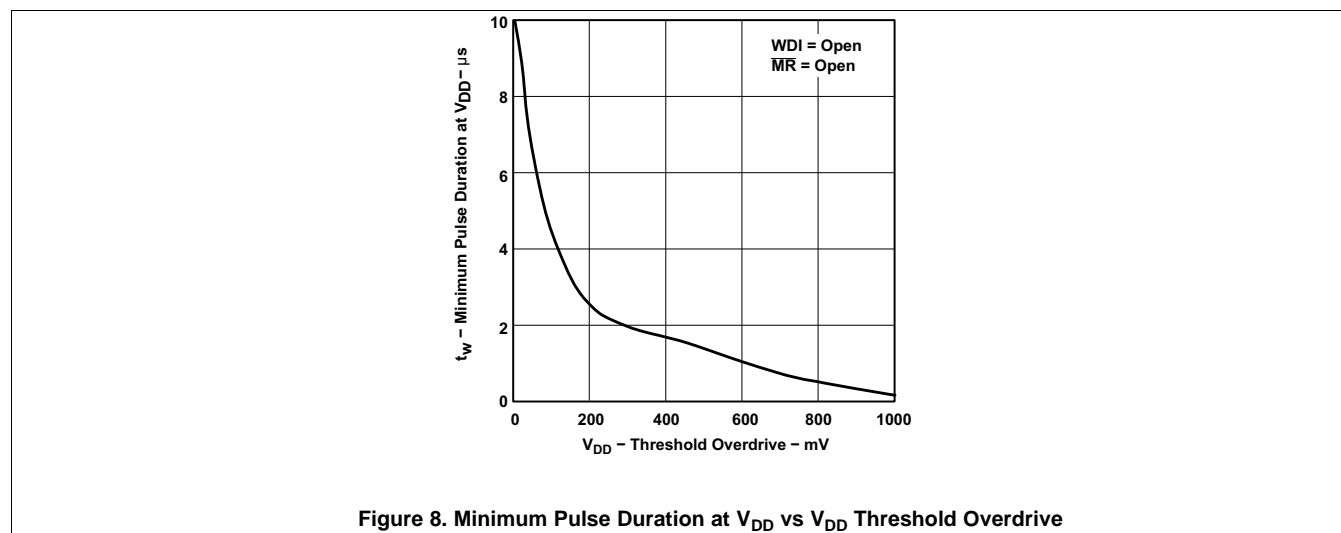

Figure 7. High-Level Output Voltage vs High-Level Output Current

Typical Characteristics (continued)



8 Detailed Description

8.1 Overview

The TPS382x-xx-Q1 family of supervisors provide circuit initialization and timing supervision. Optional configurations include devices with active-high and active-low output signals (TPS3824/5-xx-Q1), devices with a watchdog timer (TPS3820/3/4/8-xx-Q1), and devices with manual reset ($\overline{\text{MR}}$) pins (TPS3820/3/5/8-xx-Q1). $\overline{\text{RESET}}$ asserts when the supply voltage, V_{DD} , rises above 1.1 V. For devices with active-low output logic, the device monitors V_{DD} and keeps $\overline{\text{RESET}}$ low as long as V_{DD} remains below the negative threshold voltage, $V_{\text{IT-}}$. For devices with active-high output logic, $\overline{\text{RESET}}$ remains high as long as V_{DD} remains below $V_{\text{IT-}}$. An internal timer delays the return of the output to the inactive state (high) to ensure proper system reset. The delay time, t_d , starts after V_{DD} rises above the positive threshold voltage ($V_{\text{IT-}} + V_{\text{HYS}}$). When the supply voltage drops below $V_{\text{IT-}}$, the output becomes active (low) again. All the devices of this family have a fixed-sense threshold voltage, $V_{\text{IT-}}$, set by an internal voltage divider, so no external components are required.

The TPS382x-xx-Q1 family is designed to monitor supply voltages of 2.5 V, 3 V, 3.3 V, and 5 V. The devices are available in a 5-pin SOT-23 package and are characterized for operation over a temperature range of -40°C to 125°C , and are qualified in accordance with AEC-Q100 stress test qualification for integrated circuits.

8.2 Functional Block Diagram

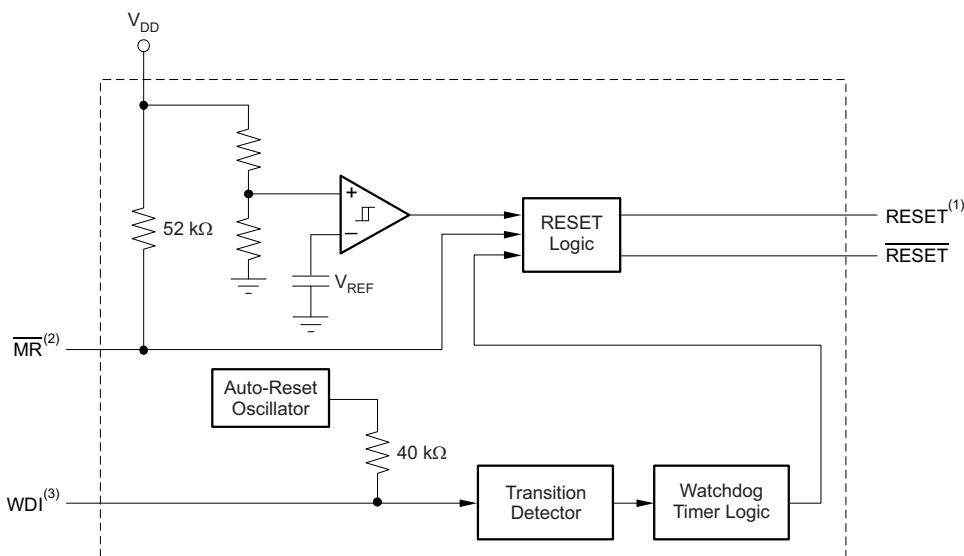

- (1) TPS3824/5-xx-Q1
- (2) TPS3820/3/5/8-xx-Q1
- (3) TPS3820/3/4/8-xx-Q1

8.3 Feature Description

8.3.1 Manual Reset ($\overline{\text{MR}}$)

The $\overline{\text{MR}}$ input allows an external logic signal from processors, logic circuits, and/or discrete sensors to force a reset signal regardless of V_{DD} with respect to $V_{\text{IT-}}$ or the state of the watchdog timer. A low level at $\overline{\text{MR}}$ causes the reset signals to become active.

8.3.2 Active High or Active Low Output

All TPS382x-xx-Q1 devices have an active-low logic output ($\overline{\text{RESET}}$), while the TPS3824/5-xx-Q1 devices also include an active-high logic output (RESET).

Feature Description (continued)

8.3.3 Push-Pull or Open-Drain Output

All TPS382x-xx-Q1 devices, except for TPS3828-xx-Q1, have push-pull outputs. TPS3828-xx-Q1 devices have an open-drain output.

8.3.4 Watchdog Timer (WDI)

TPS3820/3/4/8-xx-Q1 devices have a watchdog timer that must be periodically triggered by either a positive or negative transition at WDI to avoid a reset signal being issued. When the supervising system fails to retrigger the watchdog circuit within the time-out interval, t_{out} , \overline{RESET} becomes active for the time period t_d . This event also reinitializes the watchdog timer.

The watchdog timer can be disabled by disconnecting the WDI pin from the system. If the WDI pin detects that it is in a high-impedance state the TPS3820/3/4/8-xx-Q1 will generate its own WDI pulse to ensure that \overline{RESET} does not assert. If this behavior is not desired place a 1-k Ω resistor from WDI to ground. This resistor will help ensure that the TPS3820/3/4/8-xx-Q1 detects that WDI is not in a high-impedance state.

In applications where the input to the WDI pin is active (transitioning high and low) when the TPS3820/3/4/8-xx-Q1 is asserting \overline{RESET} , \overline{RESET} will be stuck at a logic low after the input voltage returns above V_{IT-} . If the application requires that input to WDI be active when the reset signal is asserted, then use a FET to decouple the WDI signal. An external FET decouples the WDI signal by disconnecting the WDI input when \overline{RESET} is asserted. For more details on this, see [Decoupling WDI During Reset Event](#) for more details.

8.4 Device Functional Modes

The device functions according to the inputs and outputs in [Table 1](#).

Table 1. Function Table

INPUTS		OUTPUTS	
\overline{MR} (1)	$V_{DD} > V_{IT}$	\overline{RESET}	$RESET^{(2)}$
L	0	L	H
L	1	L	H
H	0	L	H
H	1	H	L

(1) TPS3820/3/5/8-xx-Q1

(2) TPS3824/5-xx-Q1

9 Application and Implementation

NOTE

Information in the following applications sections is not part of the TI component specification, and TI does not warrant its accuracy or completeness. TI's customers are responsible for determining suitability of components for their purposes. Customers should validate and test their design implementation to confirm system functionality.

9.1 Application Information

The TPS382x-xx-Q1 family of devices are very small supervisory circuits that monitor fixed supply voltages of 2.5 V, 3 V, 3.3 V, and 5 V. The TPS382x-xx-Q1 family operates from 1.1 V to 5.5 V. Orderable options include versions with either push-pull or open-drain outputs, versions that use active-high or active-low logic for output signals, versions with a manual reset pin, and versions with a watchdog timer. See the [Device Comparison Table](#) for an overview of device options.

9.2 Typical Applications

9.2.1 Supply Rail Monitoring with Watchdog Time-out and 200-ms Delay

The TPS3823-xx-Q1 can be used to monitor the supply rail for devices such as microcontrollers. The downstream device is enabled by the TPS3823-xx-Q1 once the voltage on the supply pin (V_{DD}) is above the internal threshold voltage ($V_{IT-} + V_{HYS}$). The downstream device is disabled by the TPS3823-xx-Q1 when V_{DD} falls below the threshold voltage minus the hysteresis voltage (V_{IT-}). The TPS3823-xx-Q1 also issues a reset signal if the WDI input is not periodically triggered by a positive or negative transition at WDI. When the supervising system fails to retrigger the watchdog circuit within the time-out interval, t_{out} , \overline{RESET} becomes active for the time period t_d .

Some applications require a shorter reset signal than the 200 ms that most of the TPS382x-xx-Q1 family provide. In these cases, the TPS3820-xx-Q1 is a good choice because it has a delay time of only 25 ms. If an open-drain output is needed, replace the TPS3823-xx-Q1 with the TPS3828-xx-Q1 (if the WDI input must be active while \overline{RESET} is low, see [Decoupling WDI During Reset Event](#)). [Figure 9](#) shows the TPS3823-33-Q1 in a typical application.

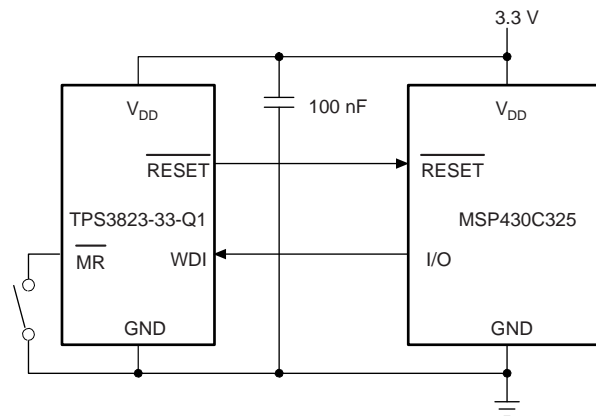

Figure 9. Supply Rail Monitoring With Watchdog Time-out

9.2.1.1 Design Requirements

The TPS3823-33-Q1 must drive the enable pin of a MSP430C325 using a logic-high signal to signify that the supply voltage is above the minimum operating voltage of the device and monitor the I/O pin to determine if the microcontroller is operating correctly.

Typical Applications (continued)

9.2.1.2 Detailed Design Procedure

Determine which version of the TPS382x-xx-Q1 family best suits the functional performance required.

If the input supply is noisy, include an input capacitor to help avoid unwanted changes to the reset signal.

9.2.1.3 Application Curve

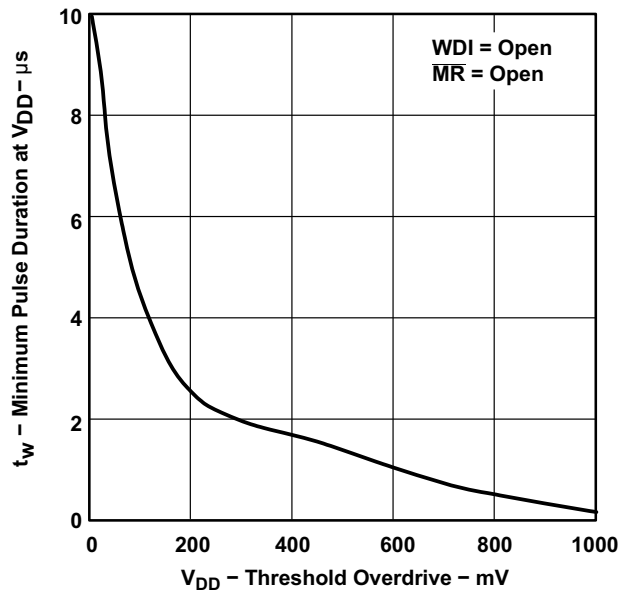

Figure 10. Minimum Pulse Duration at V_{DD} vs V_{DD} Threshold Overdrive

9.2.2 Decoupling WDI During Reset Event

If the application requires that the input to WDI is active when the reset signal is asserted, Figure 11 shows how to decouple WDI from the active signal using an N-channel FET. The N-channel FET is placed in series with the WDI pin, with the gate of the FET connected to the RESET output.

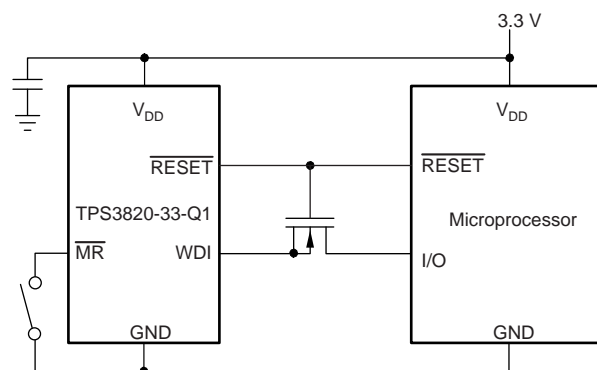

Figure 11. WDI Example

10 Power Supply Recommendations

These devices are designed to operate from an input supply with a voltage range from 1.1 V to 5.5 V. Though not required, it is good analog design practice to place a 0.1-μF ceramic capacitor close to the V_{DD} pin if the input supply is noisy.

11 Layout

11.1 Layout Guidelines

Follow these guidelines to lay out the printed-circuit-board (PCB) that is used for the TPS382x-xx-Q1 family of devices.

- Place the V_{DD} decoupling capacitor (C_{VDD}) close to the device.
- Avoid using long traces for the V_{DD} supply node. The V_{DD} capacitor (C_{VDD}), along with parasitic inductance from the supply to the capacitor, can form an LC tank and create ringing with peak voltages above the maximum V_{DD} voltage.

11.2 Layout Example

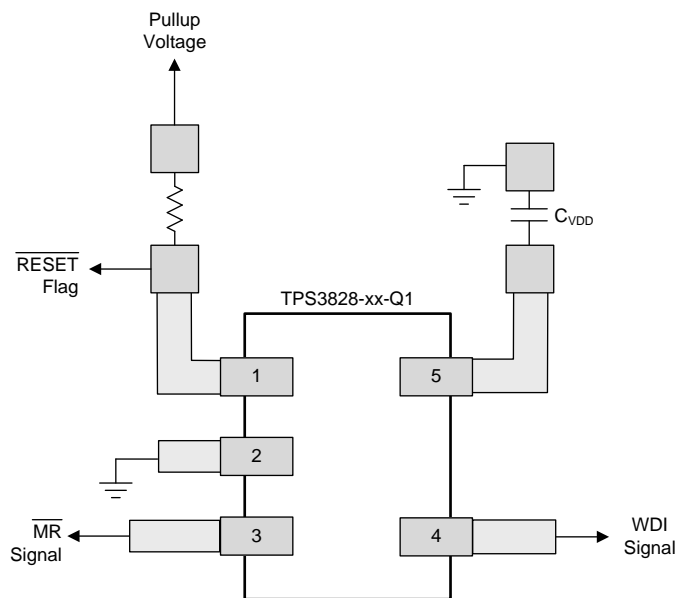

Figure 12. Example Layout (DBV Package)

12 Device and Documentation Support

12.1 Device Support

12.1.1 Development Support

12.1.1.1 Spice Models

Computer simulation of circuit performance using SPICE is often useful when analyzing the performance of analog circuits and systems. A SPICE model for the TPS382xx-Q1 is available through the product folders under *Tools & Software*.

12.2 Documentation Support

12.2.1 Related Documentation

- *Disabling the Watchdog Timer for TI's Family of Supervisors*, [SLVA145](#)

12.2.1.1 Related Links

The table below lists quick access links. Categories include technical documents, support and community resources, tools and software, and quick access to sample or buy.

Table 2. Related Links

PARTS	PRODUCT FOLDER	SAMPLE & BUY	TECHNICAL DOCUMENTS	TOOLS & SOFTWARE	SUPPORT & COMMUNITY
TPS3820-33-Q1	Click here	Click here	Click here	Click here	Click here
TPS3820-50-Q1	Click here	Click here	Click here	Click here	Click here
TPS3823-25-Q1	Click here	Click here	Click here	Click here	Click here
TPS3823-30-Q1	Click here	Click here	Click here	Click here	Click here
TPS3823-33-Q1	Click here	Click here	Click here	Click here	Click here
TPS3823-50-Q1	Click here	Click here	Click here	Click here	Click here
TPS3824-30-Q1	Click here	Click here	Click here	Click here	Click here
TPS3824-33-Q1	Click here	Click here	Click here	Click here	Click here
TPS3824-50-Q1	Click here	Click here	Click here	Click here	Click here
TPS3825-33-Q1	Click here	Click here	Click here	Click here	Click here
TPS3825-50-Q1	Click here	Click here	Click here	Click here	Click here
TPS3828-33-Q1	Click here	Click here	Click here	Click here	Click here
TPS3828-50-Q1	Click here	Click here	Click here	Click here	Click here

12.3 Community Resources

The following links connect to TI community resources. Linked contents are provided "AS IS" by the respective contributors. They do not constitute TI specifications and do not necessarily reflect TI's views; see TI's [Terms of Use](#).

TI E2E™ Online Community *TI's Engineer-to-Engineer (E2E) Community*. Created to foster collaboration among engineers. At [e2e.ti.com](#), you can ask questions, share knowledge, explore ideas and help solve problems with fellow engineers.

Design Support *TI's Design Support* Quickly find helpful E2E forums along with design support tools and contact information for technical support.

12.4 Trademarks

E2E is a trademark of Texas Instruments.
 All other trademarks are the property of their respective owners.

12.5 Electrostatic Discharge Caution



These devices have limited built-in ESD protection. The leads should be shorted together or the device placed in conductive foam during storage or handling to prevent electrostatic damage to the MOS gates.

12.6 Glossary

[SLYZ022](#) — *TI Glossary*.

This glossary lists and explains terms, acronyms, and definitions.

13 Mechanical, Packaging, and Orderable Information

The following pages include mechanical, packaging, and orderable information. This information is the most current data available for the designated devices. This data is subject to change without notice and revision of this document. For browser-based versions of this data sheet, refer to the left-hand navigation.

PACKAGING INFORMATION

Orderable Device	Status (1)	Package Type	Package Drawing	Pins	Package Qty	Eco Plan (2)	Lead/Ball Finish (6)	MSL Peak Temp (3)	Op Temp (°C)	Device Marking (4/5)	Samples
2T28-33QDBVRG4Q1	ACTIVE	SOT-23	DBV	5	3000	Green (RoHS & no Sb/Br)	CU NIPDAU	Level-1-260C-UNLIM	-40 to 125	PDIQ	Samples
2U3824-33QDBVRG4Q1	ACTIVE	SOT-23	DBV	5	3000	Green (RoHS & no Sb/Br)	CU NIPDAU	Level-1-260C-UNLIM	-40 to 125	PAVQ	Samples
TPS3820-33QDBVRQ1	NRND	SOT-23	DBV	5	3000	Green (RoHS & no Sb/Br)	CU NIPDAU	Level-1-260C-UNLIM	-40 to 125	PDEQ	
TPS3820-33QPDBVRQ1	ACTIVE	SOT-23	DBV	5	3000	Green (RoHS & no Sb/Br)	CU NIPDAU	Level-1-260C-UNLIM	-40 to 125	33PQ	Samples
TPS3820-50DBVRQ1G4	NRND	SOT-23	DBV	5	3000	Green (RoHS & no Sb/Br)	CU NIPDAU	Level-1-260C-UNLIM	-40 to 125	PKG4	
TPS3820-50QDBVRQ1	NRND	SOT-23	DBV	5	3000	Green (RoHS & no Sb/Br)	CU NIPDAU	Level-1-260C-UNLIM	-40 to 125	PDDQ	
TPS3820-50QPDBVRQ1	ACTIVE	SOT-23	DBV	5	3000	Green (RoHS & no Sb/Br)	CU NIPDAU	Level-1-260C-UNLIM	-40 to 125	50PQ	Samples
TPS3823-25QDBVRQ1	ACTIVE	SOT-23	DBV	5	3000	Green (RoHS & no Sb/Br)	CU NIPDAU	Level-1-260C-UNLIM	-40 to 125	PAPQ	Samples
TPS3823-33QDBVRQ1	ACTIVE	SOT-23	DBV	5	3000	Green (RoHS & no Sb/Br)	CU NIPDAU	Level-1-260C-UNLIM	-40 to 125	PARQ	Samples
TPS3823-50QDBVRQ1	ACTIVE	SOT-23	DBV	5	3000	Green (RoHS & no Sb/Br)	CU NIPDAU	Level-1-260C-UNLIM	-40 to 125	PASQ	Samples
TPS3824-33QDBVRQ1	ACTIVE	SOT-23	DBV	5	3000	Green (RoHS & no Sb/Br)	CU NIPDAU	Level-1-260C-UNLIM	-40 to 125	PAVQ	Samples
TPS3824-50QDBVRQ1	ACTIVE	SOT-23	DBV	5	3000	Green (RoHS & no Sb/Br)	CU NIPDAU	Level-1-260C-UNLIM	-40 to 125	PAWQ	Samples
TPS3825-33QDBVRQ1	ACTIVE	SOT-23	DBV	5	3000	Green (RoHS & no Sb/Br)	CU NIPDAU	Level-1-260C-UNLIM	-40 to 125	PDGQ	Samples
TPS3828-33QDBVRQ1	ACTIVE	SOT-23	DBV	5	3000	Green (RoHS & no Sb/Br)	CU NIPDAU	Level-1-260C-UNLIM	-40 to 125	PDIQ	Samples
TPS3828-50QDBVRG4Q	ACTIVE	SOT-23	DBV	5	3000	Green (RoHS & no Sb/Br)	CU NIPDAU	Level-1-260C-UNLIM	-40 to 125	PDHQ	Samples

(1) The marketing status values are defined as follows:

ACTIVE: Product device recommended for new designs.

LIFEBUY: TI has announced that the device will be discontinued, and a lifetime-buy period is in effect.

NRND: Not recommended for new designs. Device is in production to support existing customers, but TI does not recommend using this part in a new design.

PREVIEW: Device has been announced but is not in production. Samples may or may not be available.

OBSELETE: TI has discontinued the production of the device.

⁽²⁾ **RoHS:** TI defines "RoHS" to mean semiconductor products that are compliant with the current EU RoHS requirements for all 10 RoHS substances, including the requirement that RoHS substance do not exceed 0.1% by weight in homogeneous materials. Where designed to be soldered at high temperatures, "RoHS" products are suitable for use in specified lead-free processes. TI may reference these types of products as "Pb-Free".

RoHS Exempt: TI defines "RoHS Exempt" to mean products that contain lead but are compliant with EU RoHS pursuant to a specific EU RoHS exemption.

Green: TI defines "Green" to mean the content of Chlorine (Cl) and Bromine (Br) based flame retardants meet JS709B low halogen requirements of <=1000ppm threshold. Antimony trioxide based flame retardants must also meet the <=1000ppm threshold requirement.

⁽³⁾ MSL, Peak Temp. - The Moisture Sensitivity Level rating according to the JEDEC industry standard classifications, and peak solder temperature.

⁽⁴⁾ There may be additional marking, which relates to the logo, the lot trace code information, or the environmental category on the device.

⁽⁵⁾ Multiple Device Markings will be inside parentheses. Only one Device Marking contained in parentheses and separated by a "~" will appear on a device. If a line is indented then it is a continuation of the previous line and the two combined represent the entire Device Marking for that device.

⁽⁶⁾ Lead/Ball Finish - Orderable Devices may have multiple material finish options. Finish options are separated by a vertical ruled line. Lead/Ball Finish values may wrap to two lines if the finish value exceeds the maximum column width.

Important Information and Disclaimer:The information provided on this page represents TI's knowledge and belief as of the date that it is provided. TI bases its knowledge and belief on information provided by third parties, and makes no representation or warranty as to the accuracy of such information. Efforts are underway to better integrate information from third parties. TI has taken and continues to take reasonable steps to provide representative and accurate information but may not have conducted destructive testing or chemical analysis on incoming materials and chemicals. TI and TI suppliers consider certain information to be proprietary, and thus CAS numbers and other limited information may not be available for release.

In no event shall TI's liability arising out of such information exceed the total purchase price of the TI part(s) at issue in this document sold by TI to Customer on an annual basis.

OTHER QUALIFIED VERSIONS OF TPS3820-Q1, TPS3823-Q1, TPS3824-Q1, TPS3825-Q1, TPS3828-Q1 :

● Catalog: [TPS3820](#), [TPS3823](#), [TPS3824](#), [TPS3825](#), [TPS3828](#)

NOTE: Qualified Version Definitions:

● Catalog - TI's standard catalog product

TAPE AND REEL INFORMATION



QUADRANT ASSIGNMENTS FOR PIN 1 ORIENTATION IN TAPE



*All dimensions are nominal

Device	Package Type	Package Drawing	Pins	SPQ	Reel Diameter (mm)	Reel Width W1 (mm)	A0 (mm)	B0 (mm)	K0 (mm)	P1 (mm)	W (mm)	Pin1 Quadrant
2T28-33QDBVRG4Q1	SOT-23	DBV	5	3000	180.0	9.0	3.15	3.2	1.4	4.0	8.0	Q3
2U3824-33QDBVRG4Q1	SOT-23	DBV	5	3000	180.0	9.0	3.15	3.2	1.4	4.0	8.0	Q3
TPS3820-33QDBVRQ1	SOT-23	DBV	5	3000	180.0	9.0	3.15	3.2	1.4	4.0	8.0	Q3
TPS3820-33QPDBVRQ1	SOT-23	DBV	5	3000	180.0	8.4	3.2	3.2	1.4	4.0	8.0	Q3
TPS3820-50DBVRQ1G4	SOT-23	DBV	5	3000	180.0	9.0	3.15	3.2	1.4	4.0	8.0	Q3
TPS3820-50QDBVRQ1	SOT-23	DBV	5	3000	180.0	9.0	3.15	3.2	1.4	4.0	8.0	Q3
TPS3820-50QPDBVRQ1	SOT-23	DBV	5	3000	180.0	8.4	3.2	3.2	1.4	4.0	8.0	Q3
TPS3823-25QDBVRQ1	SOT-23	DBV	5	3000	180.0	9.0	3.15	3.2	1.4	4.0	8.0	Q3
TPS3823-33QDBVRQ1	SOT-23	DBV	5	3000	180.0	9.0	3.15	3.2	1.4	4.0	8.0	Q3
TPS3823-50QDBVRQ1	SOT-23	DBV	5	3000	180.0	9.0	3.15	3.2	1.4	4.0	8.0	Q3
TPS3824-33QDBVRQ1	SOT-23	DBV	5	3000	180.0	9.0	3.15	3.2	1.4	4.0	8.0	Q3
TPS3824-50QDBVRQ1	SOT-23	DBV	5	3000	180.0	9.0	3.15	3.2	1.4	4.0	8.0	Q3
TPS3825-33QDBVRQ1	SOT-23	DBV	5	3000	180.0	9.0	3.15	3.2	1.4	4.0	8.0	Q3
TPS3828-33QDBVRQ1	SOT-23	DBV	5	3000	180.0	9.0	3.15	3.2	1.4	4.0	8.0	Q3
TPS3828-50QDBVRG4Q	SOT-23	DBV	5	3000	180.0	9.0	3.15	3.2	1.4	4.0	8.0	Q3

TAPE AND REEL BOX DIMENSIONS

*All dimensions are nominal

Device	Package Type	Package Drawing	Pins	SPQ	Length (mm)	Width (mm)	Height (mm)
2T28-33QDBVRG4Q1	SOT-23	DBV	5	3000	182.0	182.0	20.0
2U3824-33QDBVRG4Q1	SOT-23	DBV	5	3000	182.0	182.0	20.0
TPS3820-33QDBVRQ1	SOT-23	DBV	5	3000	182.0	182.0	20.0
TPS3820-33QPDBVRQ1	SOT-23	DBV	5	3000	210.0	185.0	35.0
TPS3820-50DBVRQ1G4	SOT-23	DBV	5	3000	182.0	182.0	20.0
TPS3820-50QDBVRQ1	SOT-23	DBV	5	3000	182.0	182.0	20.0
TPS3820-50QPDBVRQ1	SOT-23	DBV	5	3000	210.0	185.0	35.0
TPS3823-25QDBVRQ1	SOT-23	DBV	5	3000	182.0	182.0	20.0
TPS3823-33QDBVRQ1	SOT-23	DBV	5	3000	182.0	182.0	20.0
TPS3823-50QDBVRQ1	SOT-23	DBV	5	3000	182.0	182.0	20.0
TPS3824-33QDBVRQ1	SOT-23	DBV	5	3000	182.0	182.0	20.0
TPS3824-50QDBVRQ1	SOT-23	DBV	5	3000	182.0	182.0	20.0
TPS3825-33QDBVRQ1	SOT-23	DBV	5	3000	182.0	182.0	20.0
TPS3828-33QDBVRQ1	SOT-23	DBV	5	3000	182.0	182.0	20.0
TPS3828-50QDBVRG4Q	SOT-23	DBV	5	3000	182.0	182.0	20.0

EXAMPLE BOARD LAYOUT

DBV0005A

SOT-23 - 1.45 mm max height

SMALL OUTLINE TRANSISTOR



LAND PATTERN EXAMPLE
EXPOSED METAL SHOWN
SCALE:15X



SOLDER MASK DETAILS

4214839/D 11/2018

NOTES: (continued)

- 5. Publication IPC-7351 may have alternate designs.
- 6. Solder mask tolerances between and around signal pads can vary based on board fabrication site.

EXAMPLE STENCIL DESIGN

DBV0005A

SOT-23 - 1.45 mm max height

SMALL OUTLINE TRANSISTOR



SOLDER PASTE EXAMPLE
BASED ON 0.125 mm THICK STENCIL
SCALE:15X

4214839/D 11/2018

NOTES: (continued)

7. Laser cutting apertures with trapezoidal walls and rounded corners may offer better paste release. IPC-7525 may have alternate design recommendations.
8. Board assembly site may have different recommendations for stencil design.

IMPORTANT NOTICE AND DISCLAIMER

TI PROVIDES TECHNICAL AND RELIABILITY DATA (INCLUDING DATASHEETS), DESIGN RESOURCES (INCLUDING REFERENCE DESIGNS), APPLICATION OR OTHER DESIGN ADVICE, WEB TOOLS, SAFETY INFORMATION, AND OTHER RESOURCES "AS IS" AND WITH ALL FAULTS, AND DISCLAIMS ALL WARRANTIES, EXPRESS AND IMPLIED, INCLUDING WITHOUT LIMITATION ANY IMPLIED WARRANTIES OF MERCHANTABILITY, FITNESS FOR A PARTICULAR PURPOSE OR NON-INFRINGEMENT OF THIRD PARTY INTELLECTUAL PROPERTY RIGHTS.

These resources are intended for skilled developers designing with TI products. You are solely responsible for (1) selecting the appropriate TI products for your application, (2) designing, validating and testing your application, and (3) ensuring your application meets applicable standards, and any other safety, security, or other requirements. These resources are subject to change without notice. TI grants you permission to use these resources only for development of an application that uses the TI products described in the resource. Other reproduction and display of these resources is prohibited. No license is granted to any other TI intellectual property right or to any third party intellectual property right. TI disclaims responsibility for, and you will fully indemnify TI and its representatives against, any claims, damages, costs, losses, and liabilities arising out of your use of these resources.

TI's products are provided subject to TI's Terms of Sale (www.ti.com/legal/termsofsale.html) or other applicable terms available either on ti.com or provided in conjunction with such TI products. TI's provision of these resources does not expand or otherwise alter TI's applicable warranties or warranty disclaimers for TI products.

Mailing Address: Texas Instruments, Post Office Box 655303, Dallas, Texas 75265
Copyright © 2019, Texas Instruments Incorporated

Looking for pricing, stock, or lifecycle information?

Click below to explore more details on WIN SOURCE:

 [View TPS3828-33QDBVRQ1 on WIN SOURCE](#)

 [Texas Instruments](#) Information

Optimize Your Supply Chain with WIN SOURCE Solutions

-  Global Sourcing Solution
-  Obsolete Management
-  Cost Control Management
-  Shortage Management
-  Alternative Solution
-  Excess Inventory Management