



**THE DATASHEET OF
TPS3813J25DBVR**



TPS3813xxx Family Processor Supervisory Circuits With Window-Watchdog

1 Features

- Window-Watchdog With Programmable Delay and Window Ratio
- 6-Pin SOT-23 Package
- Supply Current of 9 μA (Typical)
- Power-On Reset Generator With a Fixed Delay Time of 25 ms
- Precision Supply Voltage Monitor: 2.5 V, 3 V, 3.3 V, and 5 V
- Open-Drain Reset Output
- Temperature Range: -40°C to 85°C

2 Applications

- Applications Using DSPs, Microcontrollers, or Microprocessors
- Safety Critical Systems
- Automotive Systems
- Heating Systems

Typical Operating Circuit

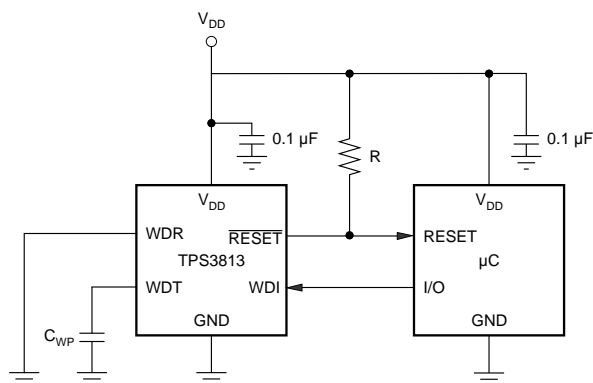

Copyright © 2016, Texas Instruments Incorporated

3 Description

The TPS3813xxx family of supervisory circuits provide circuit initialization and timing supervision, primarily for DSPs and processor-based systems.

During power on, $\overline{\text{RESET}}$ is asserted when supply voltage (V_{DD}) becomes higher than 1.1 V. Thereafter, the supervisory circuit monitors V_{DD} and keeps RESET active as long as V_{DD} remains below the threshold voltage (V_{IT}). An internal timer delays the return of the output to the inactive state (high) to ensure proper system reset. The delay time, $t_d = 25$ ms typical, starts after V_{DD} has risen above the threshold voltage (V_{IT}). When the supply voltage drops below the threshold voltage (V_{IT}), the output becomes active (low) again. No external components are required. All the devices of this family have a fixed-sense threshold voltage (V_{IT}) set by an internal voltage divider.

For safety critical applications the TPS3813xxx family incorporates a so-called window-watchdog with programmable delay and window ratio. The upper limit of the watchdog time-out can be set by either connecting WDT to GND, V_{DD} , or using an external capacitor. The lower limit and thus the window ratio is set by connecting WDR to GND or V_{DD} . The supervised processor now needs to trigger the TPS3813xxx within this window not to assert a RESET.

The product spectrum is designed for supply voltages of 2.5 V, 3 V, 3.3 V, and 5 V. The circuits are available in a 6-pin SOT-23 package.

The TPS3813xxx devices are characterized for operation over a temperature range of -40°C to 85°C .

Device Information⁽¹⁾

PART NUMBER	PACKAGE	BODY SIZE (NOM)
TPS3813xxx	SOT-23 (6)	2.90 mm x 1.60 mm

(1) For all available packages, see the orderable addendum at the end of the data sheet.



Table of Contents

1 Features 1 2 Applications 1 3 Description 1 4 Revision History 2 5 Device Comparison Table 4 6 Pin Configuration and Functions 4 7 Specifications 5 7.1 Absolute Maximum Ratings 5 7.2 ESD Ratings 5 7.3 Recommended Operating Conditions 5 7.4 Thermal Information 5 7.5 Electrical Characteristics 6 7.6 Timing Requirements 6 7.7 Switching Characteristics 6 7.8 Dissipation Ratings 7 7.9 Typical Characteristics 8 8 Detailed Description 9 8.1 Overview 9 8.2 Functional Block Diagram 9	8.3 Feature Description 9 8.4 Device Functional Modes 10 8.5 Programming 11 9 Application and Implementation 13 9.1 Application Information 13 9.2 Typical Application 13 10 Power Supply Recommendations 15 11 Layout 15 11.1 Layout Guidelines 15 11.2 Layout Example 15 12 Device and Documentation Support 16 12.1 Related Links 16 12.2 Receiving Notification of Documentation Updates 16 12.3 Community Resource 16 12.4 Trademarks 16 12.5 Electrostatic Discharge Caution 16 12.6 Glossary 16 13 Mechanical, Packaging, and Orderable Information 16
---	---

4 Revision History

NOTE: Page numbers for previous revisions may differ from page numbers in the current version.

Changes from Revision G (October 2013) to Revision H	Page
• Added <i>ESD Ratings</i> table, <i>Thermal Information</i> table, Feature Description section, <i>Device Functional Modes</i> , <i>Application and Implementation</i> section, <i>Power Supply Recommendations</i> section, <i>Layout</i> section, <i>Device and Documentation Support</i> section, and <i>Mechanical, Packaging, and Orderable Information</i> section	1
• Changed "Power up reset voltage" to "Power-on rest voltage" in <i>Electrical Characteristics</i>	6
• Changed the function table in <i>Device Functional Modes</i>	10
• Updated text in <i>Implementing Window-Watchdog Settings</i> section	11
<hr/>	
Changes from Revision F (August 2012) to Revision G	Page
• Changed voltage from 0.6 V to 1.1 V for bottom figure	7
<hr/>	
Changes from Revision E (October 2010) to Revision F	Page
• Changed from Rev E to Rev F, August 2012	1
• Deleted the Pull-up resistor value row in the ROC table	5
<hr/>	
Changes from Revision D (October 2010) to Revision E	Page
• Added Pull-up resistor value to ROC table for $\overline{\text{RESET}}$	5
<hr/>	
Changes from Revision C (April, 2008) to Revision D	Page
• Updated table pin descriptions	4
• Changed external capacitor value recommendations in paragraph 2 of <i>Programmable Window-Watchdog</i> section	11
• Added <i>Power-Up Considerations</i> section	12

- Changed [Figure 8](#)..... [13](#)

5 Device Comparison Table

$T_A^{(1)}$	DEVICE NAME	THRESHOLD VOLTAGE	MARKING
–40°C to +85°C	TPS3813J25DBV	2.25 V	PCDI
	TPS3813L30DBV	2.64 V	PEZI
	TPS3813K33DBV	2.93 V	PFAI
	TPS3813I50DBV	4.55 V	PFBI

- (1) For the most current package and ordering information see the Package Option Addendum at the end of this document, or see the device product folder at www.ti.com.

6 Pin Configuration and Functions

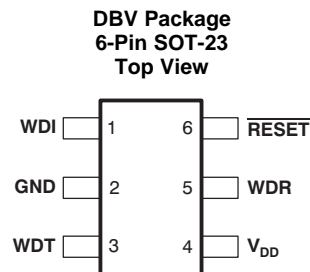

Pin Functions

PIN		I/O	DESCRIPTION
NO.	NAME		
1	WDI	I	Watchdog timer input. This input must be driven at all times and not left floating.
2	GND	I	Ground
3	WDT	I	Programmable watchdog delay input
4	V_{DD}	I	Supply voltage and supervising input
5	WDR	I	Selectable watchdog window ratio input. This input must be tied to V_{DD} or GND and not left floating.
6	$\overline{\text{RESET}}$	O	Open-drain reset output

7 Specifications

7.1 Absolute Maximum Ratings

Over operating free-air temperature range (unless otherwise noted).⁽¹⁾

		MIN	MAX	UNIT
V _{DD}	Supply voltage ⁽²⁾		7	V
	RESET	-0.3	V _{DD} + 0.3	V
	All other pins ⁽²⁾	-0.3	7	V
I _{OL}	Maximum low output current		5	mA
I _{OH}	Maximum high output current		-5	mA
I _{IK}	Input clamp current (V _I < 0 or V _I > V _{DD})		±20	mA
I _{OK}	Output clamp current (V _O < 0 or V _O > V _{DD})		±20	mA
Continuous total power dissipation		See Dissipation Ratings		
Soldering temperature			260	°C
T _A	Operating free-air temperature	-40	85	°C
T _{stg}	Storage temperature	-65	150	°C

- (1) Stresses beyond those listed under *Absolute Maximum Ratings* may cause permanent damage to the device. These are stress ratings only, which do not imply functional operation of the device at these or any other conditions beyond those indicated under *Recommended Operating Conditions*. Exposure to absolute-maximum-rated conditions for extended periods may affect device reliability.
- (2) All voltage values are with respect to GND. For reliable operation, the device must not be operated at 7 V for more than t = 1000h continuously.

7.2 ESD Ratings

		VALUE	UNIT
V _(ESD)	Electrostatic discharge	Human-body model (HBM), per ANSI/ESDA/JEDEC JS-001 ⁽¹⁾	±4000
		Charged-device model (CDM), per JEDEC specification JESD22-C101 ⁽²⁾	±1500

- (1) JEDEC document JEP155 states that 500-V HBM allows safe manufacturing with a standard ESD control process.
- (2) JEDEC document JEP157 states that 250-V CDM allows safe manufacturing with a standard ESD control process.

7.3 Recommended Operating Conditions

At specified temperature range.

		MIN	MAX	UNIT
V _{DD}	Supply voltage	2	6	V
V _I	Input voltage	0	V _{DD} + 0.3	V
V _{IH}	High-level input voltage	0.7 × V _{DD}		V
V _{IL}	Low-level input voltage		0.3 × V _{DD}	V
Δt/ΔV	Input transition rise and fall rate		100	ns/V
t _w	Pulse width of WDI trigger pulse	50		ns
T _A	Operating free-air temperature	-40	85	°C

7.4 Thermal Information

THERMAL METRIC ⁽¹⁾		TPS3813xxx	UNIT
		DBV (SOT-23)	
		6 PINS	
R _{θJA}	Junction-to-ambient thermal resistance	208.5	°C/W
R _{θJC(top)}	Junction-to-case (top) thermal resistance	123.3	°C/W
R _{θJB}	Junction-to-board thermal resistance	37.2	°C/W
ψ _{JT}	Junction-to-top characterization parameter	14.6	°C/W
ψ _{JB}	Junction-to-board characterization parameter	36.3	°C/W
R _{θJC(bot)}	Junction-to-case (bottom) thermal resistance	n/a	°C/W

- (1) For more information about traditional and new thermal metrics, see the [Semiconductor and IC Package Thermal Metrics](#) application report.

7.5 Electrical Characteristics

Over recommended operating free-air temperature range (unless otherwise noted).

PARAMETER		TEST CONDITIONS	MIN	TYP	MAX	UNIT	
V _{OL}	Low-level output voltage	V _{DD} = 2 V to 6 V, I _{OL} = 500 μA			0.2	V	
		V _{DD} = 3.3 V, I _{OL} = 2 mA			0.4		
		V _{DD} = 6 V, I _{OL} = 4 mA			0.4		
V _{POR}	Power up reset voltage ⁽¹⁾	V _{DD} ≥ 1.1 V, I _{OL} = 50 μA			0.2	V	
V _{IT}	Negative-going input threshold voltage ⁽²⁾	T _A = -40°C to +85°C	TPS3813J25	2.2	2.25	2.3	V
			TPS3813L30	2.58	2.64	2.7	
			TPS3813K33	2.87	2.93	3	
			TPS3813I50	4.45	4.55	4.65	
V _{hys}	Hysteresis		TPS3813J25		30	mV	
			TPS3813L30		35		
			TPS3813K33		40		
			TPS3813I50		60		
I _{IH}	High-level input current	WDI, WDR	WDI = V _{DD} = 6 V, WDR = V _{DD} = 6 V		-25	25	nA
		WDT	WDT = V _{DD} = 6 V, V _{DD} > V _{IT} , $\overline{\text{RESET}}$ = High		-100	100	
I _{IL}	Low-level input current	WDI, WDR	WDI = 0 V, WDR = 0 V, V _{DD} = 6 V		-25	25	nA
		WDT	WDT = 0 V, V _{DD} > V _{IT} , $\overline{\text{RESET}}$ = High		-100	100	
I _{OH}	High-level output current	V _{DD} = V _{IT} + 0.2 V, V _{OH} = V _{DD}			25	nA	
I _{DD}	Supply current	V _{DD} = 2-V output unconnected		9	13	μA	
		V _{DD} = 5-V output unconnected		20	25		
C _i	Input capacitance	V _I = 0 V to V _{DD}		5		pF	

(1) The lowest supply voltage at which $\overline{\text{RESET}}$ becomes active. t_r, V_{DD} ≥ 15 μs/V.

(2) To ensure best stability of the threshold voltage, a bypass capacitor (ceramic, 0.1 μF) must be placed near to the supply terminals.

7.6 Timing Requirements

At R_L = 1 MΩ, C_L = 50 pF, and T_A = -40°C to +85°C.

		MIN	TYP	MAX	UNIT
t _w	Pulse width at V _{DD}	V _{DD} = V _{IT-} + 0.2 V, V _{DD} = V _{IT-} - 0.2 V		3	μs

7.7 Switching Characteristics

At R_L = 1 MΩ, C_L = 50 pF, and T_A = -40°C to +85°C.

PARAMETER		TEST CONDITIONS	MIN	TYP	MAX	UNIT	
t _d	Delay time	V _{DD} ≥ V _{IT} + 0.2 V, See Figure 1	20	25	30	ms	
t _{t(out)}	Watchdog time-out	Upper limit	WDT = 0 V	0.2	0.25	0.3	s
			WDT = V _{DD}	2	2.5	3	
			WDT = programmable ⁽¹⁾	See ⁽²⁾		ms	
Watchdog window ratio		WDR = 0 V, WDT = 0 V	1:31.8				
		WDR = 0 V, WDT = V _{DD}	1:32				
		WDR = 0 V, WDT = programmable	1:25.8				
		WDR = V _{DD} , WDT = 0 V	1:124.9				
		WDR = V _{DD} , WDT = V _{DD}	1:127.7				
		WDR = V _{DD} , WDT = programmable	1:64.5				
t _{PHL}	Propagation (delay) time, high-to-low-level output	V _{DD} to $\overline{\text{RESET}}$ delay	V _{IL} = V _{IT} - 0.2 V, V _{IH} = V _{IT} + 0.2 V		30	50	μs

(1) 155 pF < C_(ext) < 63 nF

(2) (C_(ext) ÷ 15.55 pF + 1) × 6.25 ms

7.8 Dissipation Ratings

PACKAGE	T _A < 25°C POWER RATING	DERATING FACTOR ABOVE T _A = 25°C	T _A = 70°C POWER RATING	T _A = 80°C POWER RATING
DBV	437 mW	3.5 mW/°C	280 mW	227 mW

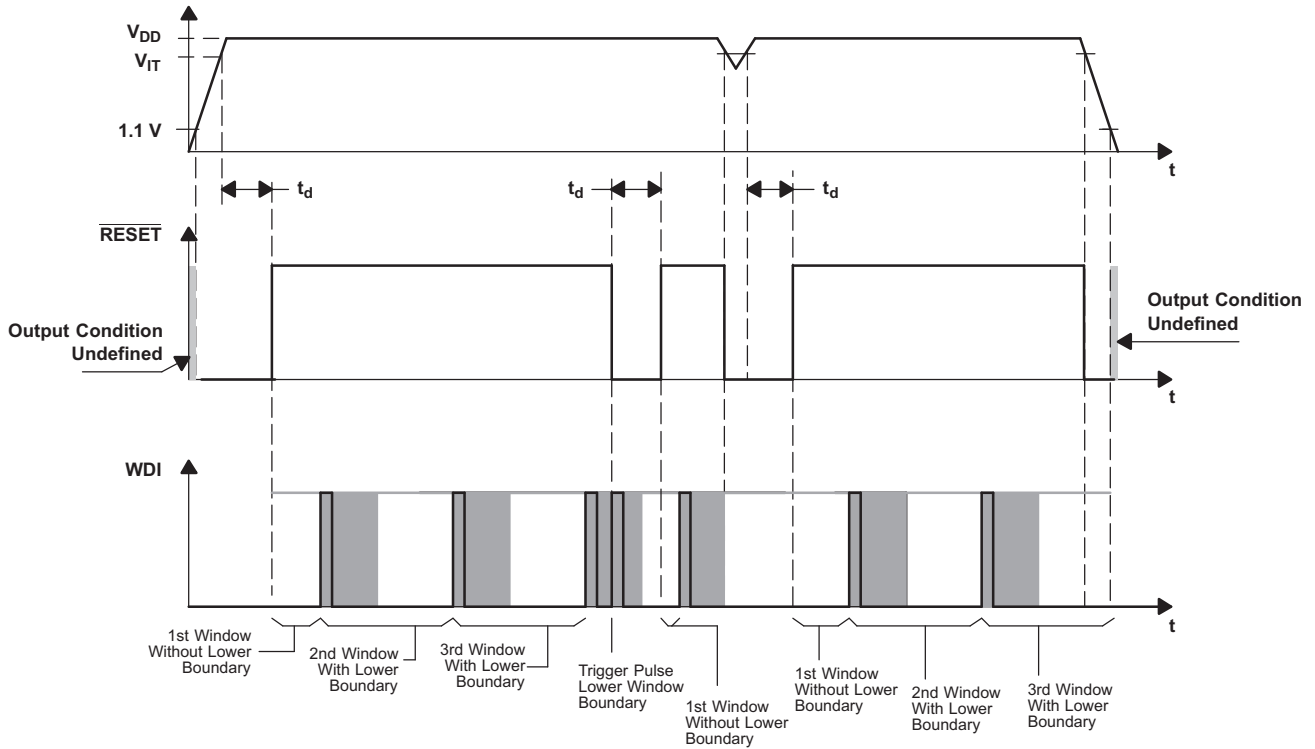

Figure 1. Timing Diagram

7.9 Typical Characteristics

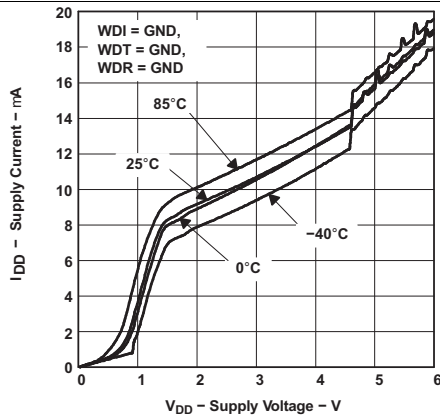

Figure 2. Supply Current vs Supply Voltage

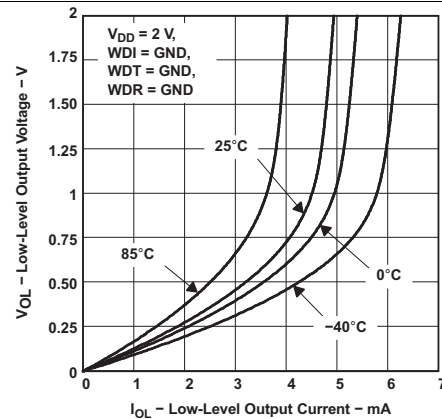

Figure 3. Low-Level Output Voltage vs Low-Level Output Current

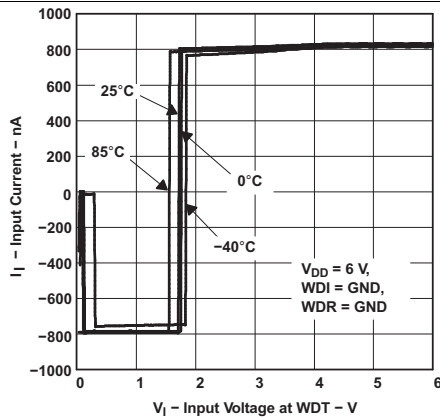

Figure 4. Input Current vs Input Voltage at WDT

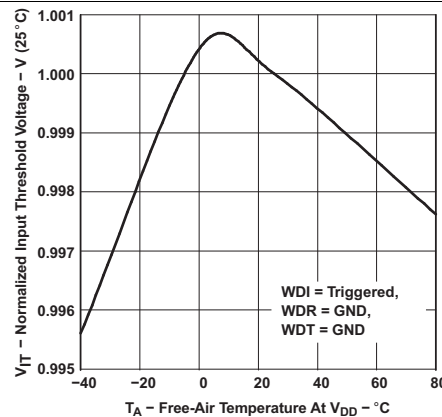

Figure 5. Normalized Input Threshold Voltage vs Free-Air Temperature at V_{DD}

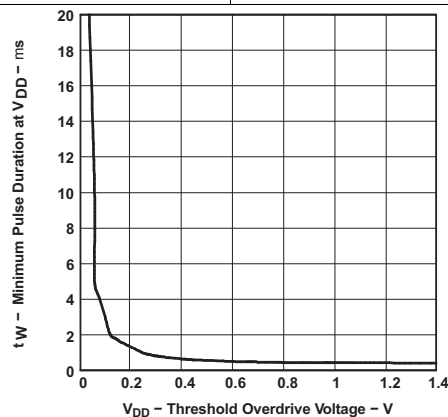

Figure 6. Minimum Pulse Duration at V_{DD} vs V_{DD} Threshold Overdrive Voltage

8 Detailed Description

8.1 Overview

The TPS3813xxx family of supervisory circuits provide circuit initialization and timing supervision signals. During power on, $\overline{\text{RESET}}$ is asserted (low) when the supply voltage (V_{DD}) increases above 1.1 V. Thereafter, the supervisory circuit monitors V_{DD} and keeps $\overline{\text{RESET}}$ low as long as V_{DD} remains below the threshold voltage (V_{IT}). Once V_{DD} increases above V_{IT} , an internal timer delays the deassertion of the output to allow for a proper system reset before $\overline{\text{RESET}}$ transitions to a high state. The delay time (t_d) is 25 ms typical and starts after V_{DD} rises above the V_{IT} . When the supply voltage drops below V_{IT} , the output transitions low again. All the devices of this family have a fixed threshold voltage set by an internal voltage divider.

The TPS3813xxx family incorporates a so-called window-watchdog timer, which has a programmable delay and window ratio. The supervised processor must trigger the WDI pin of the TPS3813xxx within the user-programmable window to keep $\overline{\text{RESET}}$ from asserting. The upper limit of the watchdog time-out can be set by either connecting WDT to GND, V_{DD} , or using an external capacitor. The lower limit and thus the window ratio is set by connecting WDR to GND or V_{DD} .

8.2 Functional Block Diagram

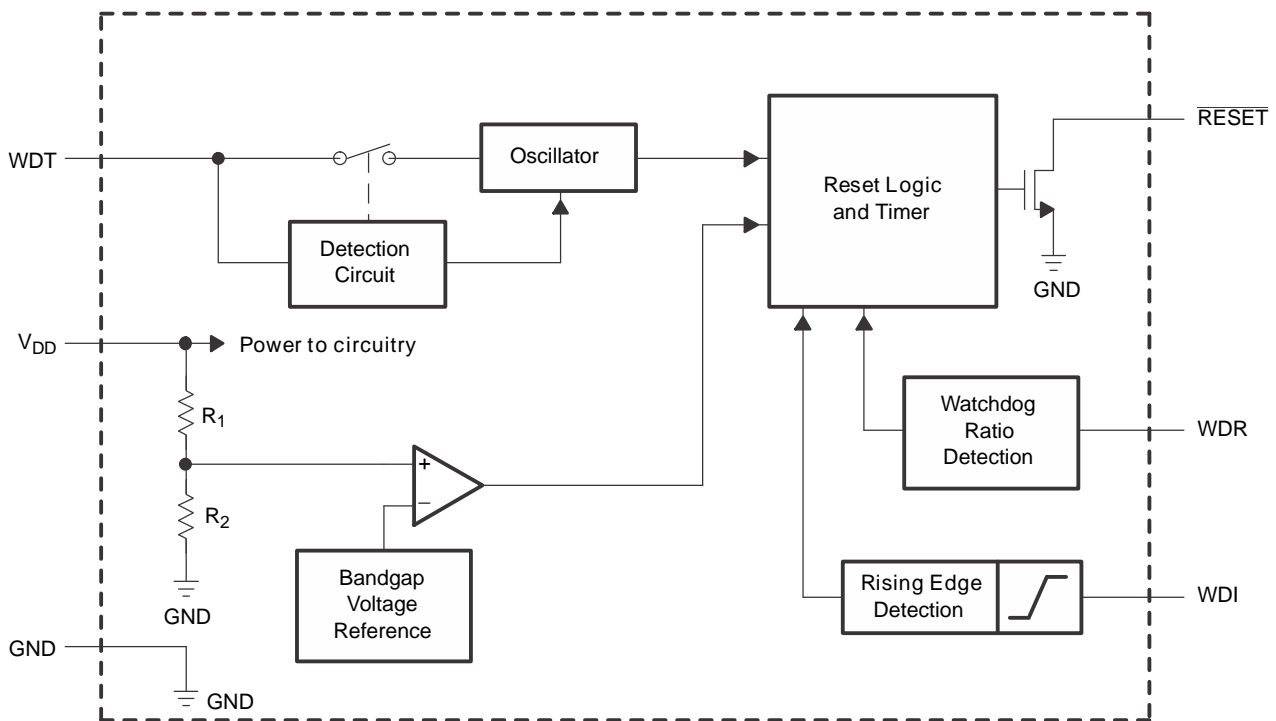

Copyright © 2016, Texas Instruments Incorporated

8.3 Feature Description

The TPS3813xxx family incorporates both a voltage supervisor and a window-watchdog timer into a single device. The device monitors the input voltage and the supervised processor must trigger the WDI pin of the TPS3813xxx within the user-programmable window to keep $\overline{\text{RESET}}$ from asserting.

Feature Description (continued)

8.3.1 User-Programmable Watchdog Timer (WDI)

The TPS3813xxx family of devices have a watchdog timer that must be periodically triggered by either a positive or negative transition at the WDI pin to avoid a reset signal being issued. When the supervising system fails to retrigger the watchdog circuit within the time-out interval, $t_{t(out)}$, $\overline{\text{RESET}}$ becomes asserted for the time period t_d . This event also reinitializes the watchdog timer. After the reset of the supervisor is released, the lower boundary of the first WDI window is disabled. After the first WDI low-to-high transition is detected, the lower boundary function of the window is enabled. All further WDI pulses must fit into the configured window frame.

Both the upper and lower boundary of the window can be adjusted by the user. See [Programming](#) for more details on how to set the upper and lower boundaries of the window.

8.3.2 $\overline{\text{RESET}}$ Output

$\overline{\text{RESET}}$ remains high (deasserted) as long as V_{DD} is above the threshold voltage (V_{IT}) and the user-programmable watchdog timer criteria are met. If V_{DD} falls below the V_{IT} or if WDI is not triggered within the appropriate window, then $\overline{\text{RESET}}$ is asserted, driving the $\overline{\text{RESET}}$ pin to a low impedance.

When V_{DD} is once again above V_{IT} , a delay circuit is enabled that holds $\overline{\text{RESET}}$ low for a specified reset delay period (t_d) which is 25 ms typical. When the reset delay has elapsed, the $\overline{\text{RESET}}$ pin goes to a high-impedance state and uses a pullup resistor to hold $\overline{\text{RESET}}$ high. Connect the pullup resistor to the proper voltage rail to enable the outputs to be connected to other devices at the correct interface voltage level. $\overline{\text{RESET}}$ can be pulled up to any voltage up to 6 V, independent of the device supply voltage. To ensure proper voltage levels, give some consideration when choosing the pullup resistor value and consider the required low-level output voltage (V_{OL}), the output capacitive loading, and the output leakage current.

8.4 Device Functional Modes

Table 1 summarizes the various functional modes of the device.

Table 1. TPS3813xxx Function/Truth Table

V_{DD}	WDI	$\overline{\text{RESET}}$
$V_{DD} < V_{POR}$	—	Undefined
$V_{POR} < V_{DD} < V_{IT}$	—	L
$V_{DD} > V_{IT}$	Outside window	L
$V_{DD} > V_{IT}$	Inside window	H

8.4.1 Normal Operation ($V_{DD} > V_{IT}$)

When V_{DD} is greater than V_{IT} , the $\overline{\text{RESET}}$ signal is determined by the last WDI pulse.

- WDI pulse inside window: as long as pulses occur within the user-programmable window, the $\overline{\text{RESET}}$ signal remains high.
- WDI pulse outside window: if a pulse occurs outside the user-programmable window or not at all, the $\overline{\text{RESET}}$ signal goes low.

8.4.2 Above Power-On Reset But Less Than Threshold ($V_{POR} < V_{DD} < V_{IT}$)

When the voltage on V_{DD} is less than the V_{IT} voltage, and greater than the power-on reset voltage (V_{POR}), the $\overline{\text{RESET}}$ signal is asserted regardless of the WDI signal.

8.4.3 Below Power-On Reset ($V_{DD} < V_{POR}$)

When the voltage on V_{DD} is lower than V_{POR} , the device does not have enough voltage to internally pull the asserted output low, and $\overline{\text{RESET}}$ is undefined and must not be relied upon for proper device function.

8.5 Programming

8.5.1 Implementing Window-Watchdog Settings

There are two ways to configure the watchdog timer window the most flexible is to connect a capacitor to WDT to set the upper boundary of the window watchdog while connecting WDR to either V_{DD} or GND, thus setting the lower boundary. The other way to configure the timing is by wiring the WDT and WDR pin to either V_{DD} or GND. By hardwiring the pins to either V_{DD} or GND there are four different timings available; these settings are listed in Table 2.

Table 2. Cap-Free Timer Settings

SELECTED OPERATION MODE		WINDOW FRAME	LOWER WINDOW FRAME
WDT = 0 V	WDR = 0 V	Max = 0.3 s	Max = 9.46 ms
		Typ = 0.25 s	Typ = 7.86 ms
		Min = 0.2 s	Min = 6.27 ms
	WDR = V_{DD}	Max = 0.3 s	Max = 2.43 ms
		Typ = 0.25 s	Typ = 2 ms
		Min = 0.2 s	Min = 1.58 ms
WDT = V_{DD}	WDR = 0 V	Max = 3 s	Max = 93.8 ms
		Typ = 2.5 s	Typ = 78.2 ms
		Min = 2 s	Min = 62.5 ms
	WDR = V_{DD}	Max = 3 s	Max = 23.5 ms
		Typ = 2.5 s	Typ = 19.6 ms
		Min = 2 s	Min = 15.6 ms

To visualize the values named in the table, a timing diagram was prepared. It is used to describe the upper and lower boundary settings. For an application, the important boundaries are the $t_{\text{boundary,max}}$ and $t_{\text{window,min}}$. Within these values, the watchdog timer must be retriggered to avoid a time-out condition or a boundary violation in the event of a trigger pulse in the lower boundary. The values in the table above are typical and worst-case conditions. They are valid over the whole temperature range of -40°C to $+85^{\circ}\text{C}$.

In the shaded area of Figure 7, it cannot be predicted if the device detects a violation or not and release a reset. This is also the case between the boundary tolerance of $t_{\text{boundary,min}}$ and $t_{\text{boundary,max}}$ as well as between $t_{\text{window,min}}$ and $t_{\text{window,max}}$. It is important to set up the trigger pulses accordingly to avoid violations in these areas.

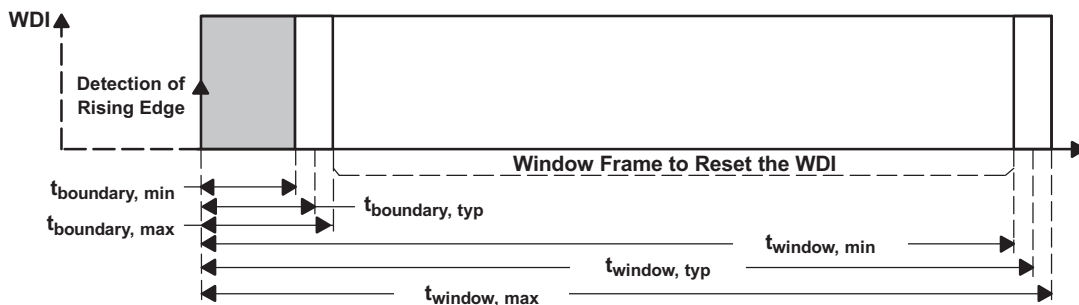

Figure 7. Upper and Lower Boundary Visualization

8.5.2 Programmable Window-Watchdog by Using an External Capacitor

The upper boundary of the watchdog timer can be set by an external capacitor connected between the WDT pin and GND. Common consumer electronic capacitors can be used to implement this feature. They must have low ESR and low tolerances because the tolerances have to be considered if the calculations are performed. The first formula is used to calculate the upper window frame. After calculating the upper window frame, the lower boundary can be calculated. As in the last example, the most important values are the $t_{\text{boundary,max}}$ and $t_{\text{window,min}}$. The trigger pulse has to fit into this window frame.

The external capacitor must have a value between a minimum of 155 pF and a maximum of 63 nF.

Table 3. Setting Upper Window Using External Capacitor

SELECTED OPERATION MODE		WINDOW FRAME
WDT = external capacitor $C_{(ext)}$	WDR = 0 V and WDR = V_{DD}	$t_{window,max} = 1.25 \times t_{window,typ}$
		$t_{window,min} = 0.75 \times t_{window,typ}$

$$t_{window,typ} = \left(\frac{C_{(ext)}}{15.55 \text{ pF}} + 1 \right) \times 6.25 \text{ ms} \quad (1)$$

8.5.3 Lower Boundary Calculation

The lower boundary can be calculated based on the values given in [Switching Characteristics](#). Additionally, facts must be considered to verify that the lower boundary is where it is expected. Because the internal oscillator of the window watchdog is running free, any rising edge at the WDI pin is considered at the next internal clock cycle. This happens regardless of the external source. Because the shift between internal and external clock is not known, it is best to consider the worst-case condition for calculating this value.

Table 4. Setting Lower Boundary Using External Cap

SELECTED OPERATION MODE		LOWER BOUNDARY OF FRAME
WDT = external capacitor $C_{(ext)}$	WDR = 0 V	$t_{boundary,max} = t_{window,max} / 23.5$
		$t_{boundary,typ} = t_{window,typ} / 25.8$
		$t_{boundary,min} = t_{window,min} / 28.7$
	WDR = V_{DD}	$t_{boundary,max} = t_{window,max} / 51.6$
		$t_{boundary,typ} = t_{window,typ} / 64.5$
		$t_{boundary,min} = t_{window,min} / 92.7$

8.5.4 Watchdog Software Considerations

To benefit from the window watchdog feature and help the watchdog timer monitor the software execution more closely, TI recommends that the watchdog be set and reset at different points in the program rather than pulsing the watchdog input periodically by using the prescaler of a microcontroller or DSP. Furthermore, the watchdog trigger pulses must be set to different timings inside the window frame to release a defined reset, if the program must hang in any subroutine. This allows the window watchdog to detect time-outs of the trigger pulse, as well as pulses that distort the lower boundary.

8.5.5 Power-Up Considerations

Many microcontrollers use general-purpose input and output (GPIO) pins that can be programmed to be either inputs or outputs. During power-up, these I/O pins are typically configured as inputs. If a GPIO pin is used to drive the WDI input pin of the TPS3813xxx, then a pulldown resistor (shown as R2 in [Figure 8](#)) must be added to keep the WDI pin from floating during power up.

9 Application and Implementation

NOTE

Information in the following applications sections is not part of the TI component specification, and TI does not warrant its accuracy or completeness. TI's customers are responsible for determining suitability of components for their purposes. Customers should validate and test their design implementation to confirm system functionality.

9.1 Application Information

The TPS3813xxx is a voltage supervisor that incorporates a window-watchdog timer, allowing for comprehensive supervision of microcontrollers and other similar devices. The TPS3813xxx can be operated from a V_{DD} rail of 2 V to 6 V with a user-programmable watchdog time-out from 0.25 s to 2.5 s. The following sections describe how to properly use this device, depending on the requirements of the final application.

9.2 Typical Application

A typical application example (see Figure 8) is used to describe the function of the watchdog in more detail.

To configure the window watchdog function, two pins are provided by the TPS3813xxx. These pins set the window time-out and ratio.

The window watchdog ratio is a fixed ratio, which determines the lower boundary of the window frame. It can be configured in two different frame sizes.

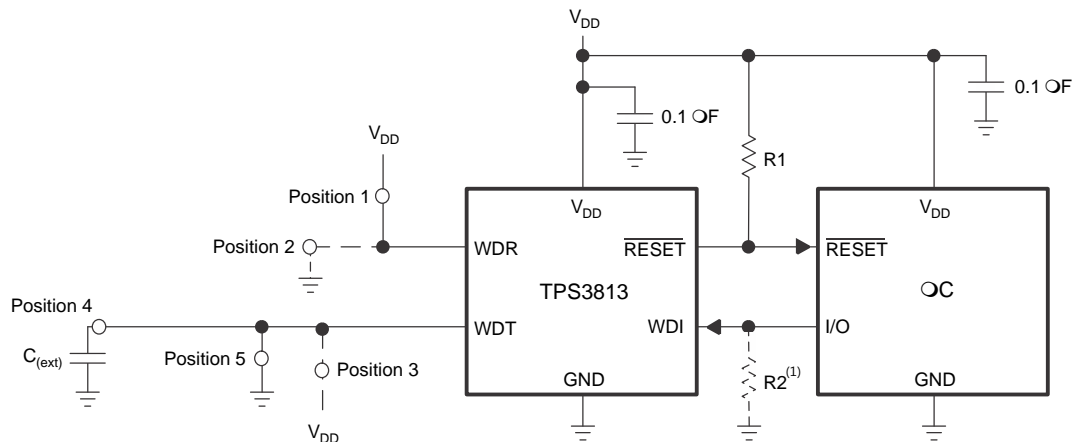

Copyright © 2016, Texas Instruments Incorporated

- (1) Use this pull-down resistor if a GPIO pin is used to drive the WDI input pin of the TPS3813xxx to keep the WDI pin from floating during power up.

Figure 8. Application Example

9.2.1 Design Requirements

The TPS3813xxx $\overline{\text{RESET}}$ output can be used to drive the $\overline{\text{RESET}}$ pin of a microcontroller to initiate a reset event. The $\overline{\text{RESET}}$ pin of the TPS3813xxx can be pulled high with a 1-M Ω resistor; the watchdog window timing is controlled by the WDT and WDR pins, and is set depending on the reset requirement times of the microprocessor.

9.2.2 Detailed Design Procedure

If the window watchdog ratio pin (WDR) is set to V_{DD}, Position 1 in Figure 8, then the lower window frame is a value based on a ratio calculation of the overall window time-out size: For the watchdog time-out pin (WDT) connected to GND, it is a ratio of 1:124.9, for WDT connected to V_{DD}, it is a ratio of 1:127.7, and for an external capacitor connected to WDT, it is a ratio of 1:64.5.

Typical Application (continued)

If the window watchdog ratio pin (WDR) is set to GND, Position 2, the lower window frame is a value based on a ratio calculation of the overall window time-out size: For the watchdog time-out pin (WDT) connected to GND, it is a ratio of 1:31.8, for WDT connected to V_{DD} it is 1:32, and for an external capacitor connected to WDT it is 1:25.8.

The watchdog time-out can be set in two fixed timings of 0.25 seconds and 2.5 seconds for the window or can be programmed by connecting an external capacitor with a low leakage current at WDT.

Example: If the watchdog time-out pin (WDT) is connected to V_{DD} , the time-out is 2.5 seconds. If the window watchdog ratio pin (WDR) is set in this configuration to a ratio of 1:127.7 by connecting the pin to V_{DD} , the lower boundary is 19.6 ms.

9.2.3 Application Curve

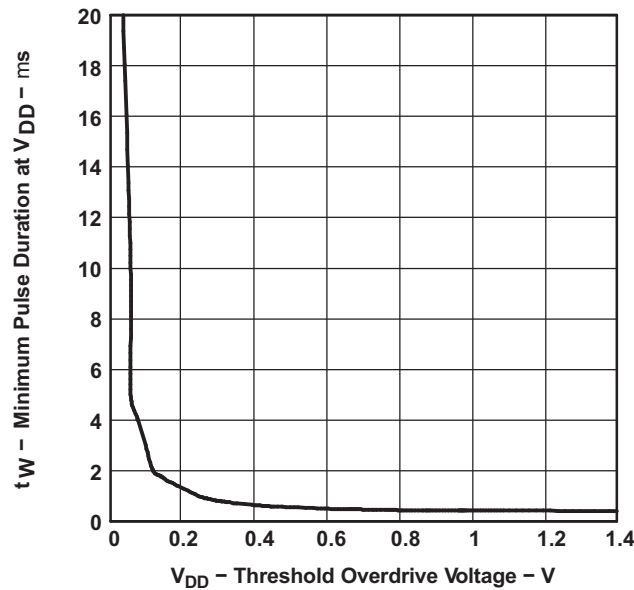

Figure 9. Minimum Pulse Duration at V_{DD} vs V_{DD} Threshold Overdrive Voltage

10 Power Supply Recommendations

These devices are designed to operate from an input supply with a voltage range from 2 V to 6 V. An input supply capacitor is not required for this device; however, if the input supply is noisy, then good analog practice is to place a 0.1- μ F capacitor between the VDD pin and the GND pin. This device has a 7-V absolute maximum rating on the VDD pin. If the voltage supply providing power to VDD is susceptible to any large voltage transient that can exceed 7 V, additional precautions must be taken.

In applications where the WDI input may experience a negative voltage while V_{DD} is ramping from 0 V to 0.8 V, the V_{DD} slew rate in this range must be greater than 10 V/s. A negative voltage on the WDI input along with a slew rate less than 10 V/s could result in a greatly reduced watchdog window time and reset output delay time.

11 Layout

11.1 Layout Guidelines

Make sure that the connection to the VDD pin is low impedance. Good analog design practice is to place a 0.1- μ F ceramic bypass capacitor near the VDD pin.

11.2 Layout Example

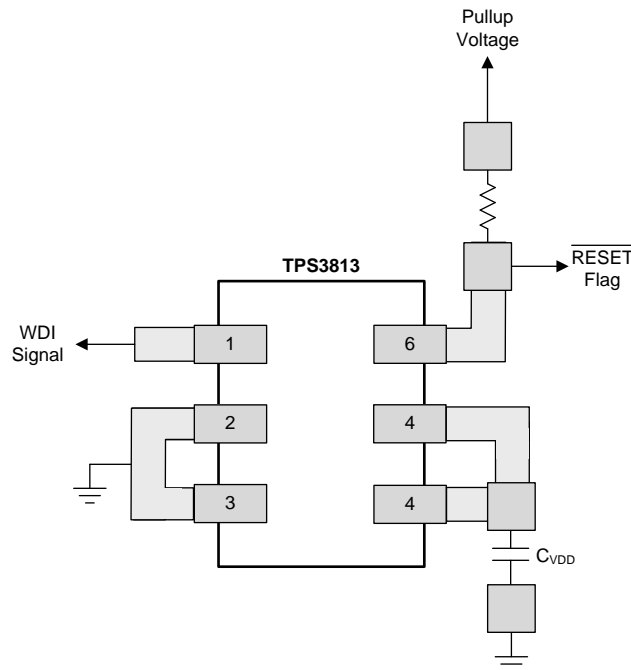

Figure 10. TPS3813xxx Layout Example

12 Device and Documentation Support

12.1 Related Links

The table below lists quick access links. Categories include technical documents, support and community resources, tools and software, and quick access to sample or buy.

Table 5. Related Links

PARTS	PRODUCT FOLDER	SAMPLE & BUY	TECHNICAL DOCUMENTS	TOOLS & SOFTWARE	SUPPORT & COMMUNITY
TPS3813J25	Click here	Click here	Click here	Click here	Click here
TPS3813L30	Click here	Click here	Click here	Click here	Click here
TPS3813K33	Click here	Click here	Click here	Click here	Click here
TPS3813I50	Click here	Click here	Click here	Click here	Click here

12.2 Receiving Notification of Documentation Updates

To receive notification of documentation updates, navigate to the device product folder on ti.com. In the upper right corner, click on *Alert me* to register and receive a weekly digest of any product information that has changed. For change details, review the revision history included in any revised document.

12.3 Community Resource

The following links connect to TI community resources. Linked contents are provided "AS IS" by the respective contributors. They do not constitute TI specifications and do not necessarily reflect TI's views; see TI's [Terms of Use](#).

TI E2E™ Online Community *TI's Engineer-to-Engineer (E2E) Community*. Created to foster collaboration among engineers. At e2e.ti.com, you can ask questions, share knowledge, explore ideas and help solve problems with fellow engineers.

Design Support *TI's Design Support* Quickly find helpful E2E forums along with design support tools and contact information for technical support.

12.4 Trademarks

E2E is a trademark of Texas Instruments.
All other trademarks are the property of their respective owners.

12.5 Electrostatic Discharge Caution



These devices have limited built-in ESD protection. The leads should be shorted together or the device placed in conductive foam during storage or handling to prevent electrostatic damage to the MOS gates.

12.6 Glossary

[SLYZ022](#) — *TI Glossary*.

This glossary lists and explains terms, acronyms, and definitions.

13 Mechanical, Packaging, and Orderable Information

The following pages include mechanical, packaging, and orderable information. This information is the most current data available for the designated devices. This data is subject to change without notice and revision of this document. For browser-based versions of this data sheet, refer to the left-hand navigation.

PACKAGING INFORMATION

Orderable Device	Status (1)	Package Type	Package Drawing	Pins	Package Qty	Eco Plan (2)	Lead/Ball Finish (6)	MSL Peak Temp (3)	Op Temp (°C)	Device Marking (4/5)	Samples
TPS3813I50DBVR	ACTIVE	SOT-23	DBV	6	3000	Green (RoHS & no Sb/Br)	CU NIPDAU	Level-1-260C-UNLIM	-40 to 85	PFBI	Samples
TPS3813I50DBVT	ACTIVE	SOT-23	DBV	6	250	Green (RoHS & no Sb/Br)	CU NIPDAU	Level-1-260C-UNLIM	-40 to 85	PFBI	Samples
TPS3813J25DBVR	ACTIVE	SOT-23	DBV	6	3000	Green (RoHS & no Sb/Br)	CU NIPDAU	Level-1-260C-UNLIM	-40 to 85	PCDI	Samples
TPS3813J25DBVRG4	ACTIVE	SOT-23	DBV	6	3000	Green (RoHS & no Sb/Br)	CU NIPDAU	Level-1-260C-UNLIM	-40 to 85	PCDI	Samples
TPS3813J25DBVT	ACTIVE	SOT-23	DBV	6	250	Green (RoHS & no Sb/Br)	CU NIPDAU	Level-1-260C-UNLIM	-40 to 85	PCDI	Samples
TPS3813K33DBVR	ACTIVE	SOT-23	DBV	6	3000	Green (RoHS & no Sb/Br)	CU NIPDAU	Level-1-260C-UNLIM	-40 to 85	PFAI	Samples
TPS3813K33DBVRG4	ACTIVE	SOT-23	DBV	6	3000	Green (RoHS & no Sb/Br)	CU NIPDAU	Level-1-260C-UNLIM	-40 to 85	PFAI	Samples
TPS3813K33DBVT	ACTIVE	SOT-23	DBV	6	250	Green (RoHS & no Sb/Br)	CU NIPDAU	Level-1-260C-UNLIM	-40 to 85	PFAI	Samples
TPS3813K33DBVTG4	ACTIVE	SOT-23	DBV	6	250	Green (RoHS & no Sb/Br)	CU NIPDAU	Level-1-260C-UNLIM	-40 to 85	PFAI	Samples
TPS3813L30DBVR	ACTIVE	SOT-23	DBV	6	3000	Green (RoHS & no Sb/Br)	CU NIPDAU	Level-1-260C-UNLIM	-40 to 85	PEZI	Samples
TPS3813L30DBVRG4	ACTIVE	SOT-23	DBV	6	3000	Green (RoHS & no Sb/Br)	CU NIPDAU	Level-1-260C-UNLIM	-40 to 85	PEZI	Samples
TPS3813L30DBVT	ACTIVE	SOT-23	DBV	6	250	Green (RoHS & no Sb/Br)	CU NIPDAU	Level-1-260C-UNLIM	-40 to 85	PEZI	Samples

(1) The marketing status values are defined as follows:

ACTIVE: Product device recommended for new designs.

LIFEBUY: TI has announced that the device will be discontinued, and a lifetime-buy period is in effect.

NRND: Not recommended for new designs. Device is in production to support existing customers, but TI does not recommend using this part in a new design.

PREVIEW: Device has been announced but is not in production. Samples may or may not be available.

OBSELETE: TI has discontinued the production of the device.

(2) **RoHS:** TI defines "RoHS" to mean semiconductor products that are compliant with the current EU RoHS requirements for all 10 RoHS substances, including the requirement that RoHS substance do not exceed 0.1% by weight in homogeneous materials. Where designed to be soldered at high temperatures, "RoHS" products are suitable for use in specified lead-free processes. TI may reference these types of products as "Pb-Free".

RoHS Exempt: TI defines "RoHS Exempt" to mean products that contain lead but are compliant with EU RoHS pursuant to a specific EU RoHS exemption.

Green: TI defines "Green" to mean the content of Chlorine (Cl) and Bromine (Br) based flame retardants meet JS709B low halogen requirements of ≤ 1000 ppm threshold. Antimony trioxide based flame retardants must also meet the ≤ 1000 ppm threshold requirement.

- (3) MSL, Peak Temp. - The Moisture Sensitivity Level rating according to the JEDEC industry standard classifications, and peak solder temperature.
- (4) There may be additional marking, which relates to the logo, the lot trace code information, or the environmental category on the device.
- (5) Multiple Device Markings will be inside parentheses. Only one Device Marking contained in parentheses and separated by a "~" will appear on a device. If a line is indented then it is a continuation of the previous line and the two combined represent the entire Device Marking for that device.
- (6) Lead/Ball Finish - Orderable Devices may have multiple material finish options. Finish options are separated by a vertical ruled line. Lead/Ball Finish values may wrap to two lines if the finish value exceeds the maximum column width.

Important Information and Disclaimer: The information provided on this page represents TI's knowledge and belief as of the date that it is provided. TI bases its knowledge and belief on information provided by third parties, and makes no representation or warranty as to the accuracy of such information. Efforts are underway to better integrate information from third parties. TI has taken and continues to take reasonable steps to provide representative and accurate information but may not have conducted destructive testing or chemical analysis on incoming materials and chemicals. TI and TI suppliers consider certain information to be proprietary, and thus CAS numbers and other limited information may not be available for release.

In no event shall TI's liability arising out of such information exceed the total purchase price of the TI part(s) at issue in this document sold by TI to Customer on an annual basis.

OTHER QUALIFIED VERSIONS OF TPS3813 :

- Automotive: [TPS3813-Q1](#)

NOTE: Qualified Version Definitions:

- Automotive - Q100 devices qualified for high-reliability automotive applications targeting zero defects

TAPE AND REEL INFORMATION

QUADRANT ASSIGNMENTS FOR PIN 1 ORIENTATION IN TAPE

*All dimensions are nominal

Device	Package Type	Package Drawing	Pins	SPQ	Reel Diameter (mm)	Reel Width W1 (mm)	A0 (mm)	B0 (mm)	K0 (mm)	P1 (mm)	W (mm)	Pin1 Quadrant
TPS3813I50DBVR	SOT-23	DBV	6	3000	178.0	9.0	3.23	3.17	1.37	4.0	8.0	Q3
TPS3813I50DBVT	SOT-23	DBV	6	250	178.0	9.0	3.23	3.17	1.37	4.0	8.0	Q3
TPS3813J25DBVR	SOT-23	DBV	6	3000	178.0	9.0	3.23	3.17	1.37	4.0	8.0	Q3
TPS3813J25DBVT	SOT-23	DBV	6	250	178.0	9.0	3.23	3.17	1.37	4.0	8.0	Q3
TPS3813K33DBVR	SOT-23	DBV	6	3000	178.0	9.0	3.23	3.17	1.37	4.0	8.0	Q3
TPS3813K33DBVT	SOT-23	DBV	6	3000	179.0	8.4	3.2	3.2	1.4	4.0	8.0	Q3
TPS3813K33DBVT	SOT-23	DBV	6	250	179.0	8.4	3.2	3.2	1.4	4.0	8.0	Q3
TPS3813K33DBVT	SOT-23	DBV	6	250	178.0	9.0	3.23	3.17	1.37	4.0	8.0	Q3
TPS3813L30DBVR	SOT-23	DBV	6	3000	178.0	9.0	3.23	3.17	1.37	4.0	8.0	Q3
TPS3813L30DBVT	SOT-23	DBV	6	250	178.0	9.0	3.23	3.17	1.37	4.0	8.0	Q3

TAPE AND REEL BOX DIMENSIONS

*All dimensions are nominal

Device	Package Type	Package Drawing	Pins	SPQ	Length (mm)	Width (mm)	Height (mm)
TPS3813I50DBVR	SOT-23	DBV	6	3000	180.0	180.0	18.0
TPS3813I50DBVT	SOT-23	DBV	6	250	180.0	180.0	18.0
TPS3813J25DBVR	SOT-23	DBV	6	3000	180.0	180.0	18.0
TPS3813J25DBVT	SOT-23	DBV	6	250	180.0	180.0	18.0
TPS3813K33DBVR	SOT-23	DBV	6	3000	180.0	180.0	18.0
TPS3813K33DBVT	SOT-23	DBV	6	3000	203.0	203.0	35.0
TPS3813K33DBVT	SOT-23	DBV	6	250	203.0	203.0	35.0
TPS3813K33DBVT	SOT-23	DBV	6	250	180.0	180.0	18.0
TPS3813L30DBVR	SOT-23	DBV	6	3000	180.0	180.0	18.0
TPS3813L30DBVT	SOT-23	DBV	6	250	180.0	180.0	18.0

DBV0006A



PACKAGE OUTLINE

SOT-23 - 1.45 mm max height

SMALL OUTLINE TRANSISTOR



4214840/B 03/2018

NOTES:

1. All linear dimensions are in millimeters. Any dimensions in parenthesis are for reference only. Dimensioning and tolerancing per ASME Y14.5M.
2. This drawing is subject to change without notice.
3. Body dimensions do not include mold flash or protrusion. Mold flash and protrusion shall not exceed 0.15 per side.
4. Leads 1,2,3 may be wider than leads 4,5,6 for package orientation.
5. Reference JEDEC MO-178.

EXAMPLE BOARD LAYOUT

DBV0006A

SOT-23 - 1.45 mm max height

SMALL OUTLINE TRANSISTOR



LAND PATTERN EXAMPLE
EXPOSED METAL SHOWN
SCALE:15X

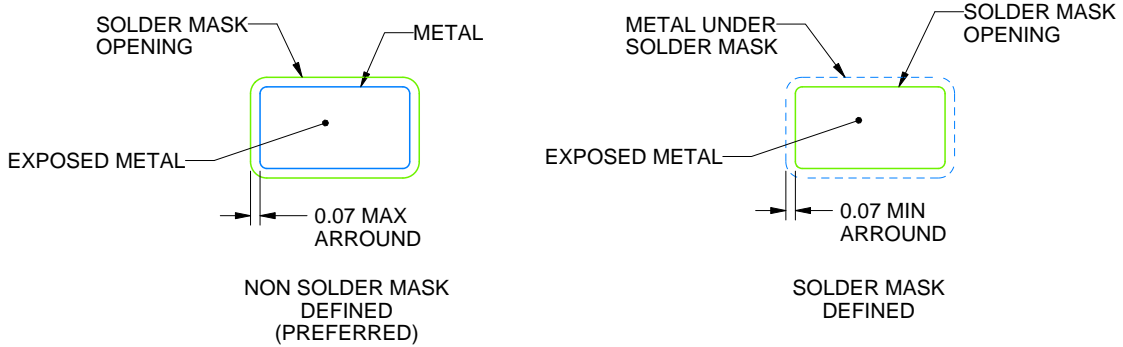

SOLDER MASK DETAILS

4214840/B 03/2018

NOTES: (continued)

- 6. Publication IPC-7351 may have alternate designs.
- 7. Solder mask tolerances between and around signal pads can vary based on board fabrication site.

EXAMPLE STENCIL DESIGN

DBV0006A

SOT-23 - 1.45 mm max height

SMALL OUTLINE TRANSISTOR



SOLDER PASTE EXAMPLE
BASED ON 0.125 mm THICK STENCIL
SCALE:15X

4214840/B 03/2018

NOTES: (continued)

8. Laser cutting apertures with trapezoidal walls and rounded corners may offer better paste release. IPC-7525 may have alternate design recommendations.
9. Board assembly site may have different recommendations for stencil design.

IMPORTANT NOTICE AND DISCLAIMER

TI PROVIDES TECHNICAL AND RELIABILITY DATA (INCLUDING DATASHEETS), DESIGN RESOURCES (INCLUDING REFERENCE DESIGNS), APPLICATION OR OTHER DESIGN ADVICE, WEB TOOLS, SAFETY INFORMATION, AND OTHER RESOURCES "AS IS" AND WITH ALL FAULTS, AND DISCLAIMS ALL WARRANTIES, EXPRESS AND IMPLIED, INCLUDING WITHOUT LIMITATION ANY IMPLIED WARRANTIES OF MERCHANTABILITY, FITNESS FOR A PARTICULAR PURPOSE OR NON-INFRINGEMENT OF THIRD PARTY INTELLECTUAL PROPERTY RIGHTS.

These resources are intended for skilled developers designing with TI products. You are solely responsible for (1) selecting the appropriate TI products for your application, (2) designing, validating and testing your application, and (3) ensuring your application meets applicable standards, and any other safety, security, or other requirements. These resources are subject to change without notice. TI grants you permission to use these resources only for development of an application that uses the TI products described in the resource. Other reproduction and display of these resources is prohibited. No license is granted to any other TI intellectual property right or to any third party intellectual property right. TI disclaims responsibility for, and you will fully indemnify TI and its representatives against, any claims, damages, costs, losses, and liabilities arising out of your use of these resources.

TI's products are provided subject to TI's Terms of Sale (www.ti.com/legal/termsofsale.html) or other applicable terms available either on ti.com or provided in conjunction with such TI products. TI's provision of these resources does not expand or otherwise alter TI's applicable warranties or warranty disclaimers for TI products.

Mailing Address: Texas Instruments, Post Office Box 655303, Dallas, Texas 75265
Copyright © 2019, Texas Instruments Incorporated

Looking for pricing, stock, or lifecycle information?

Click below to explore more details on WIN SOURCE:

 [View TPS3813J25DBVR on WIN SOURCE](#)

 [Texas Instruments](#) Information

Optimize Your Supply Chain with WIN SOURCE Solutions

-  Global Sourcing Solution
-  Obsolete Management
-  Cost Control Management
-  Shortage Management
-  Alternative Solution
-  Excess Inventory Management