



**THE DATASHEET OF  
TPS3809L30DBVR**



## TPS3809x 3-Pin Supply Voltage Supervisors

### 1 Features

- 3-pin SOT-23 package
- Supply current of 9  $\mu$ A (typical)
- Precision supply voltage monitor  
2.5 V, 3 V, 3.3 V, 5 V
- Pin-for-pin compatible with MAX 809
- Temperature range:  $-40^{\circ}\text{C}$  to  $+85^{\circ}\text{C}$

### 2 Applications

- [Factory automation](#)
- [Wireless speakers](#)
- [Motor drives](#)
- [Servers](#)
- [Appliances](#)
- [Electricity meters](#)
- [Building automation](#)

### 3 Description

The TPS3809 family of supervisory circuits provides circuit initialization and timing supervision, primarily for DSPs and processor-based systems. The newer [TLV809E](#) device is an alternative with the same pins, functions and electrical parameters.

During power-on,  $\overline{\text{RESET}}$  is asserted when the supply voltage  $V_{\text{DD}}$  becomes higher than 1.1 V. Thereafter, the supervisory circuit monitors  $V_{\text{DD}}$  and keeps  $\overline{\text{RESET}}$  active as long as  $V_{\text{DD}}$  remains below the threshold voltage  $V_{\text{IT}}$ . An internal timer delays the return of the output to the inactive state (high) to ensure proper system reset. The delay time,  $t_{\text{d(typ)}} = 200$  ms, starts after  $V_{\text{DD}}$  has risen above the threshold voltage  $V_{\text{IT}}$ . When the supply voltage drops below the threshold voltage  $V_{\text{IT}}$ , the output becomes active (low) again. No external components are required. All the devices of this family have a fixed sense-threshold voltage  $V_{\text{IT}}$  set by an internal voltage divider.

The product spectrum is designed for supply voltages of 2.5 V, 3 V, 3.3 V, and 5 V. The circuits are available in a 3-pin SOT-23. The TPS3809 devices are characterized for operation over a temperature range of  $-40^{\circ}\text{C}$  to  $85^{\circ}\text{C}$ .

#### Device Information

PART NUMBER	PACKAGE <sup>(1)</sup>	BODY SIZE (NOM)
TPS3809	SOT-23 (3), DBV	2.90 mm $\times$ 1.60 mm

(1) For all available packages, see the orderable addendum at the end of the data sheet.

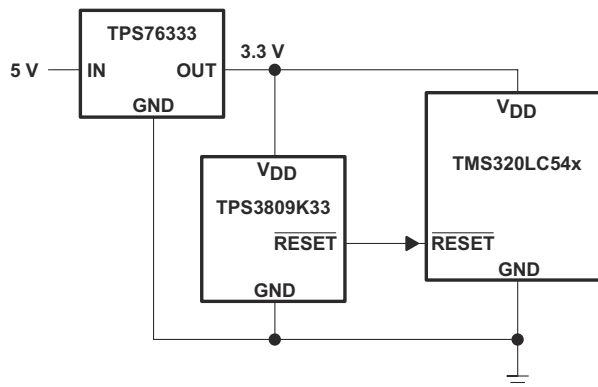

Typical Application



## Table of Contents

<b>1 Features</b> .....	1	7.3 Dissipation Ratings.....	5
<b>2 Applications</b> .....	1	7.4 Electrical Characteristics.....	5
<b>3 Description</b> .....	1	7.5 Timing Requirements.....	6
<b>4 Revision History</b> .....	2	7.6 Switching Characteristics.....	6
<b>5 Device Comparison</b> .....	3	7.7 Timing Diagram.....	6
<b>6 Pin Configuration and Functions</b> .....	4	7.8 Typical Characteristics.....	7
<b>7 Specifications</b> .....	5	<b>8 Detailed Description</b> .....	9
7.1 Absolute Maximum Ratings <sup>(1)</sup> <sup>(2)</sup> .....	5	<b>9 Electrostatic Discharge Caution</b> .....	9
7.2 Recommended Operating Conditions.....	5		

## 4 Revision History

Changes from Revision C (October 2013) to Revision D (January 2021)	Page
• Updated the numbering format for tables, figures, and cross-references throughout the document.....	1
• Added new sentence regarding the new TLV809E to the <i>Description</i> section.....	1
• Added the pinout and pin function table.....	4
• Changed VDD from 7 to 6.5 in <i>Absolute Maximum Ratings</i> .....	5
• Changed V <sub>OL</sub> @ 500μA from 0.2 to 0.3V and corrected header of the table from TPS3800-xx, TPS3801-xx, TPS3802-xx to TPS3809xx in <i>Electrical Characteristics</i> .....	5
• Changed t <sub>w</sub> pulse duration from 3 to 10μs in <i>Timing Requirements</i> .....	6
• Changed t <sub>PHL</sub> from 1 to 10μs in <i>Switching Characteristics</i> .....	6
Changes from Revision B (July 2012) to Revision C (October 2013)	Page
• Changed front page and page flow to match current standard look and feel.....	1
• Changed "Operating junction temperature range" to "Operating free-air temperature range" in Absolute Maximum Ratings (typo).....	5
Changes from Revision A (October 2010) to Revision B (July 2012)	Page
• Changed the Pull-up resistor value, $\overline{\text{RESET}}$ To: $\overline{\text{RESET}}$ current sink during startup in the Recommended Operating Conditions Table.....	5
Changes from Revision * (August 1999) to Revision A (October 2010)	Page
• Added Pull-up resistor value, $\overline{\text{RESET}}$ to the Recommended Operating Conditions Table.....	5

## 5 Device Comparison

**Table 5-1. Device Comparison Table**

T <sub>A</sub>	DEVICE NAME		THRESHOLD VOLTAGE	MARKING
-40°C to 85°C	TPS3809J25DBVR	TPS3809J25DBVT	2.25 V	PCZI
	TPS3809L30DBVR	TPS3809L30DBVT	2.64 V	PDAI
	TPS3809K33DBVR	TPS3809K33DBVT	2.93 V	PDBI
	TPS3809I50DBVR	TPS3809I50DBVT	4.55 V	PDCI

**FUNCTION/TRUTH TABLE, TPS3809**

V <sub>DD</sub> >V <sub>IT</sub>	$\overline{\text{RESET}}$
0	L
1	H

**ORDERING INFORMATION**

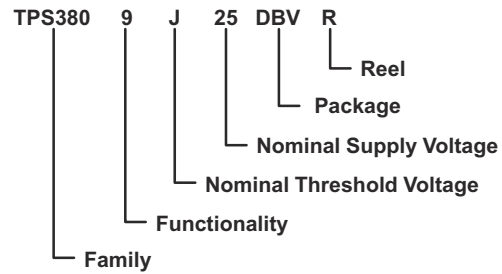

## 6 Pin Configuration and Functions

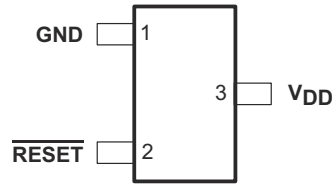

**Figure 6-1. Pin configuration**

**Table 6-1. Pin Functions**

PIN		I/O <sup>(1)</sup>	DESCRIPTION
NAME	NO.		
GND	1	-	This pin should be connected to ground with a low-impedance connection.
RESET	2	O	RESET is an active low signal, asserting when V <sub>DD</sub> is below the threshold voltage. When V <sub>DD</sub> rises above V <sub>IT</sub> , there is a delay time (t <sub>d</sub> ) until RESET deasserts. RESET is a push-pull output stage.
VDD	3	-	Supply voltage pin. A 0.1-μF ceramic capacitor from this pin to ground is recommended to improve stability of the threshold voltage

## 7 Specifications

### 7.1 Absolute Maximum Ratings <sup>(1)</sup> <sup>(2)</sup>

Over operating free-air temperature range (unless otherwise noted).

	UNIT
Supply voltage, $V_{DD}$	6.5 V
All other pins	-0.3 V to 6.5 V
Maximum low-output current, $I_{OL}$	5 mA
Maximum high-output current, $I_{OH}$	-5 mA
Input-clamp current, $I_{IK}$ ( $V_I < 0$ or $V_I > V_{DD}$ )	$\pm 20$ mA
Output-clamp current, $I_{OK}$ ( $V_O < 0$ or $V_O > V_{DD}$ )	$\pm 20$ mA
Continuous total power dissipation	See Dissipation Rating Table
Operating free-air temperature range, $T_A$	-40°C to 85°C
Storage temperature range, $T_{stg}$	-65°C to 150°C

- (1) Stresses beyond those listed under *absolute maximum ratings* may cause permanent damage to the device. These are stress ratings only, and functional operation of the device at these or any other conditions beyond those indicated under *recommended operating conditions* is not implied. Exposure to absolute-maximum-rated conditions for extended periods may affect device reliability.
- (2) All voltage values are with respect to GND. For reliable operation, the device should not be operated at 6.5 V for more than  $t = 1000$ h continuously.

### 7.2 Recommended Operating Conditions

	MIN	MAX	UNIT
Supply voltage, $V_{DD}$	2	6	V
RESET current sink during startup		50	$\mu$ A
Operating free-air temperature range, $T_A$	-40	+85	°C

### 7.3 Dissipation Ratings

PACKAGE	$T_A < 25^\circ\text{C}$ POWER RATING	DERATING FACTOR ABOVE $T_A < 25^\circ\text{C}$	$T_A = 70^\circ\text{C}$ POWER RATING	$T_A = 85^\circ\text{C}$ POWER RATING
DBV	437 mW	3.5 mW/°C	280 mW	227 mW

### 7.4 Electrical Characteristics

Over recommended operating free-air temperature range (unless otherwise noted).

PARAMETER	TEST CONDITIONS	TPS3809xx			UNIT	
		MIN	TYP	MAX		
$V_{OH}$ High-level output voltage	$V_{DD} = 2.5$ V to 6 V $I_{OH} = -500$ $\mu$ A	$V_{DD} - 0.2$			V	
	$V_{DD} = 3.3$ V $I_{OH} = -2$ mA	$V_{DD} - 0.4$				
	$V_{DD} = 6$ V $I_{OH} = -4$ mA	$V_{DD} - 0.4$				
$V_{OL}$ Low-level output voltage	$V_{DD} = 2$ V to 6 V, $I_{OL} = 500$ $\mu$ A			0.3	V	
	$V_{DD} = 3.3$ V, $I_{OL} = 2$ mA			0.4		
	$V_{DD} = 6$ V, $I_{OL} = 4$ mA			0.4		
Power-up reset voltage <sup>(1)</sup>	$V_{DD} \geq 1.1$ V, $I_{OL} = 50$ $\mu$ A			0.2	V	
$V_{IT-}$ Negative-going input threshold voltage <sup>(2)</sup>	TPS3809J25	$T_A = -40^\circ\text{C}$ to $85^\circ\text{C}$	2.2	2.25	2.3	V
	TPS3809L30		2.58	2.64	2.7	
	TPS3809K33		2.87	2.93	2.99	
	TPS3809I50		4.45	4.55	4.65	
$V_{hys}$ Threshold hysteresis	TPS3809J25		30		mV	
	TPS3809L30		35			
	TPS3809K33		40			
	TPS3809I50		60			

Over recommended operating free-air temperature range (unless otherwise noted).

PARAMETER		TEST CONDITIONS	TPS3809xx			UNIT
			MIN	TYP	MAX	
I <sub>DD</sub>	Supply current	V <sub>DD</sub> = 2 V, output unconnected		9	12	μA
		V <sub>DD</sub> = 6 V, output unconnected		20	25	
C <sub>i</sub>	Input capacitance	V <sub>I</sub> = 0 V to V <sub>DD</sub>		5		pF

- (1) The lowest supply voltage at which  $\overline{\text{RESET}}$  becomes active.  $t_r, V_{DD} \geq 15 \mu\text{s/V}$ .
- (2) To ensure the best stability of the threshold voltage, a bypass capacitor (0.1-μF ceramic) should be placed near the supply terminals.

## 7.5 Timing Requirements

 at  $R_L = 1 \text{ M}\Omega$ ,  $C_L = 50 \text{ pF}$ ,  $T_A = 25^\circ\text{C}$ 

PARAMETER		TEST CONDITIONS	MIN	TYP	MAX	UNIT
t <sub>w</sub>	Pulse width	at V <sub>DD</sub>		10		μs

## 7.6 Switching Characteristics

 at  $R_L = 1 \text{ M}\Omega$ ,  $C_L = 50 \text{ pF}$ ,  $T_A = 25^\circ\text{C}$ 

PARAMETER		TEST CONDITIONS	MIN	TYP	MAX	UNIT
t <sub>d</sub>	Delay time	V <sub>DD</sub> ≥ V <sub>IT-</sub> + 0.2 V, See <a href="#">timing diagram</a>	120	200	280	ms
t <sub>PHL</sub>	Propagation (delay) time, high-to-low-level output	V <sub>DD</sub> to $\overline{\text{RESET}}$ delay V <sub>IL</sub> = V <sub>IT-</sub> - 0.2 V, V <sub>IH</sub> = V <sub>IT-</sub> + 0.2 V		10		μs

## 7.7 Timing Diagram

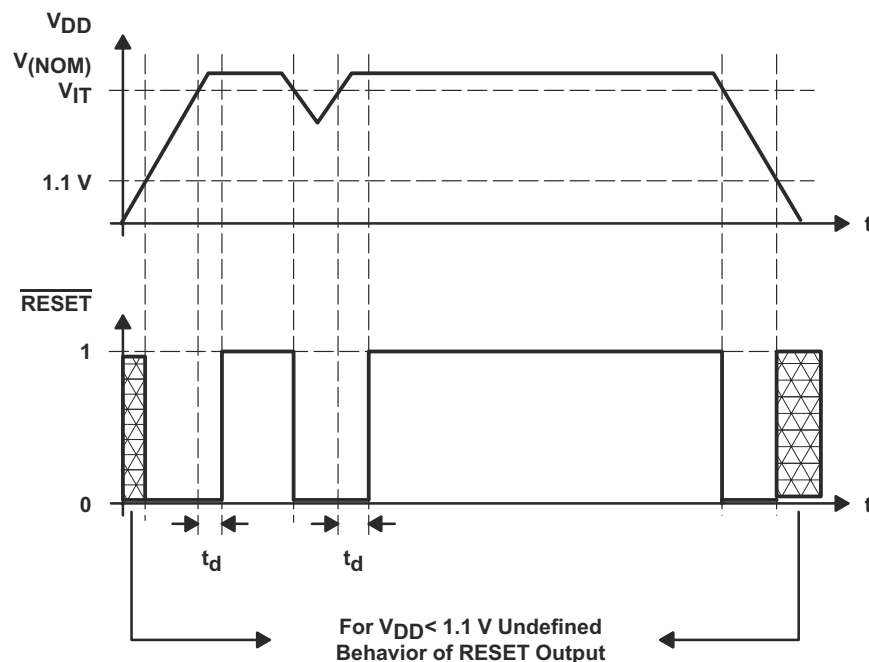

## 7.8 Typical Characteristics

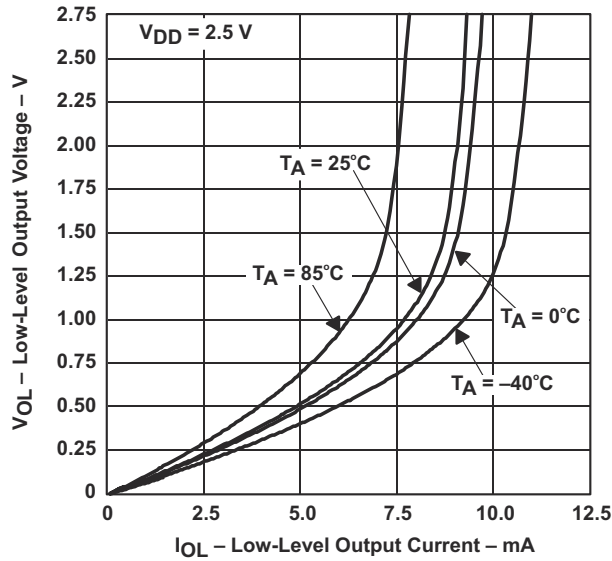

Figure 7-1. LOW-LEVEL OUTPUT VOLTAGE vs LOW-LEVEL OUTPUT CURRENT

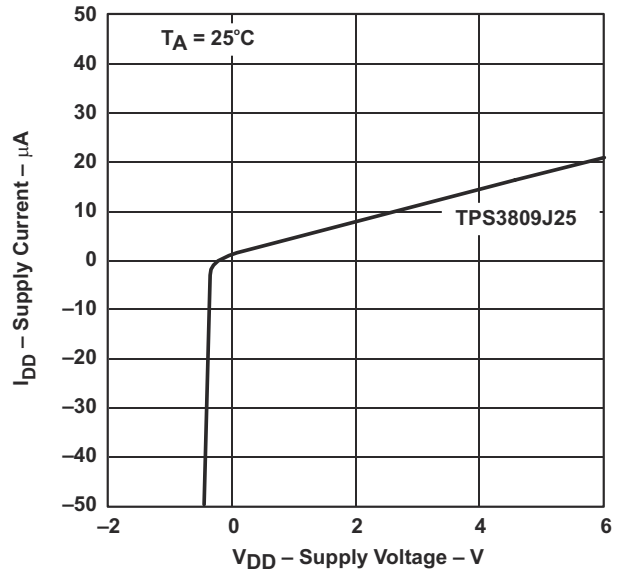

Figure 7-2. SUPPLY CURRENT vs SUPPLY VOLTAGE

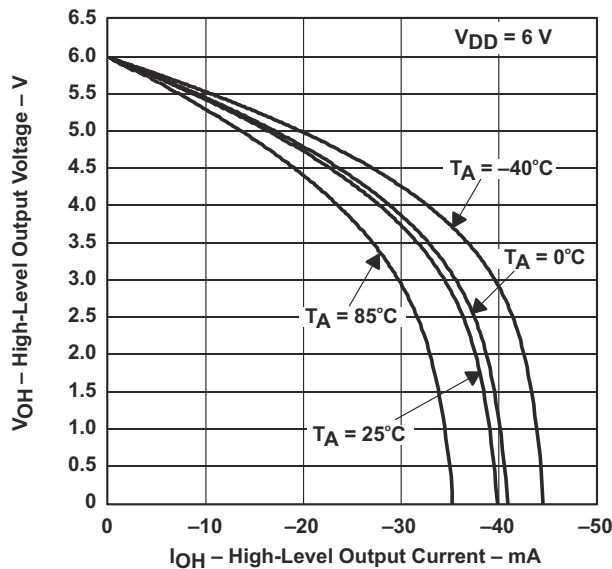

Figure 7-3. HIGH-LEVEL OUTPUT VOLTAGE vs HIGH-LEVEL OUTPUT CURRENT at  $V_{DD}=6V$

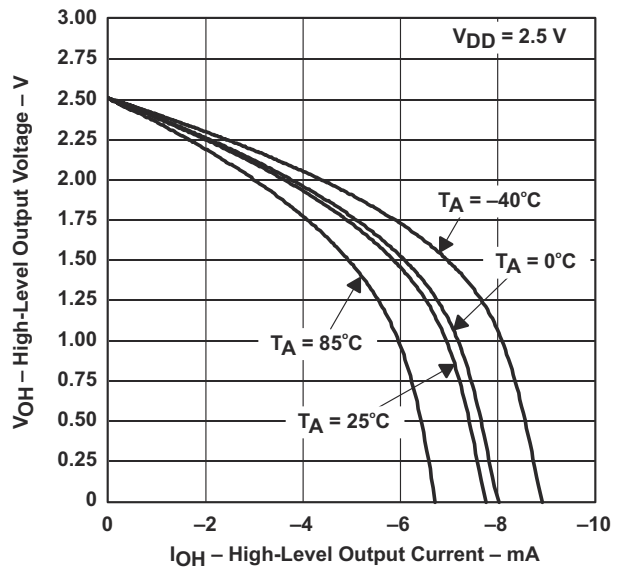

Figure 7-4. HIGH-LEVEL OUTPUT VOLTAGE vs HIGH-LEVEL OUTPUT CURRENT at  $V_{DD}=2.5V$

## 7.8 Typical Characteristics (continued)

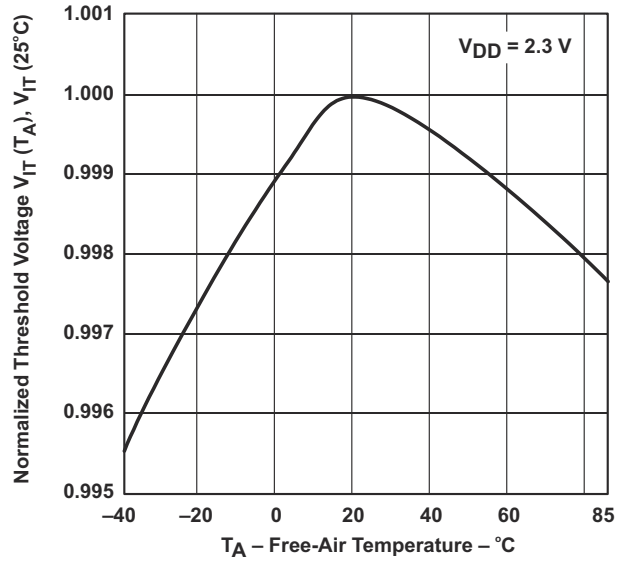
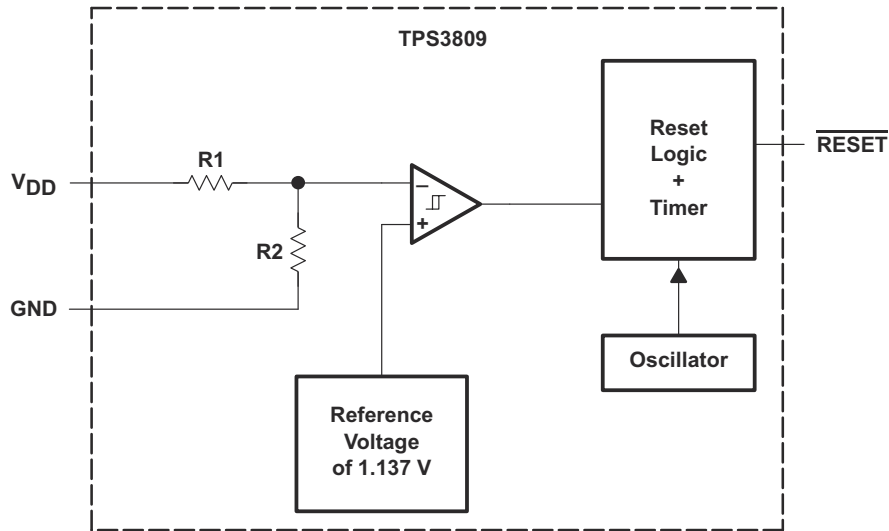

Figure 7-5. NORMALIZED INPUT THRESHOLD VOLTAGE vs FREE-AIR TEMPERATURE AT  $V_{DD}=2.3V$

## 8 Detailed Description



## 9 Electrostatic Discharge Caution



This integrated circuit can be damaged by ESD. Texas Instruments recommends that all integrated circuits be handled with appropriate precautions. Failure to observe proper handling and installation procedures can cause damage.

ESD damage can range from subtle performance degradation to complete device failure. Precision integrated circuits may be more susceptible to damage because very small parametric changes could cause the device not to meet its published specifications.

**PACKAGING INFORMATION**

Orderable Device	Status (1)	Package Type	Package Drawing	Pins	Package Qty	Eco Plan (2)	Lead finish/ Ball material (6)	MSL Peak Temp (3)	Op Temp (°C)	Device Marking (4/5)	Samples
TPS3809I50DBVR	ACTIVE	SOT-23	DBV	3	3000	RoHS & Green	NIPDAU	Level-1-260C-UNLIM	-40 to 85	PDCI	<a href="#">Samples</a>
TPS3809I50DBVRG4	ACTIVE	SOT-23	DBV	3	3000	TBD	Call TI	Call TI	-40 to 85		<a href="#">Samples</a>
TPS3809I50DBVT	ACTIVE	SOT-23	DBV	3	250	RoHS & Green	NIPDAU	Level-1-260C-UNLIM	-40 to 85	PDCI	<a href="#">Samples</a>
TPS3809J25DBVR	ACTIVE	SOT-23	DBV	3	3000	RoHS & Green	NIPDAU	Level-1-260C-UNLIM	-40 to 85	PCZI	<a href="#">Samples</a>
TPS3809J25DBVT	ACTIVE	SOT-23	DBV	3	250	RoHS & Green	NIPDAU	Level-1-260C-UNLIM	-40 to 85	PCZI	<a href="#">Samples</a>
TPS3809K33DBVR	ACTIVE	SOT-23	DBV	3	3000	RoHS & Green	NIPDAU	Level-1-260C-UNLIM	-40 to 85	PDBI	<a href="#">Samples</a>
TPS3809K33DBVRG4	ACTIVE	SOT-23	DBV	3	3000	TBD	Call TI	Call TI	-40 to 85		<a href="#">Samples</a>
TPS3809K33DBVT	ACTIVE	SOT-23	DBV	3	250	RoHS & Green	NIPDAU	Level-1-260C-UNLIM	-40 to 85	PDBI	<a href="#">Samples</a>
TPS3809L30DBVR	ACTIVE	SOT-23	DBV	3	3000	RoHS & Green	NIPDAU	Level-1-260C-UNLIM	-40 to 85	PDAI	<a href="#">Samples</a>
TPS3809L30DBVRG4	ACTIVE	SOT-23	DBV	3	3000	TBD	Call TI	Call TI	-40 to 85		<a href="#">Samples</a>
TPS3809L30DBVT	ACTIVE	SOT-23	DBV	3	250	RoHS & Green	NIPDAU	Level-1-260C-UNLIM	-40 to 85	PDAI	<a href="#">Samples</a>

(1) The marketing status values are defined as follows:

**ACTIVE:** Product device recommended for new designs.

**LIFEBUY:** TI has announced that the device will be discontinued, and a lifetime-buy period is in effect.

**NRND:** Not recommended for new designs. Device is in production to support existing customers, but TI does not recommend using this part in a new design.

**PREVIEW:** Device has been announced but is not in production. Samples may or may not be available.

**OBSELETE:** TI has discontinued the production of the device.

(2) **RoHS:** TI defines "RoHS" to mean semiconductor products that are compliant with the current EU RoHS requirements for all 10 RoHS substances, including the requirement that RoHS substance do not exceed 0.1% by weight in homogeneous materials. Where designed to be soldered at high temperatures, "RoHS" products are suitable for use in specified lead-free processes. TI may reference these types of products as "Pb-Free".

**RoHS Exempt:** TI defines "RoHS Exempt" to mean products that contain lead but are compliant with EU RoHS pursuant to a specific EU RoHS exemption.

**Green:** TI defines "Green" to mean the content of Chlorine (Cl) and Bromine (Br) based flame retardants meet JS709B low halogen requirements of <=1000ppm threshold. Antimony trioxide based flame retardants must also meet the <=1000ppm threshold requirement.

(3) MSL, Peak Temp. - The Moisture Sensitivity Level rating according to the JEDEC industry standard classifications, and peak solder temperature.

(4) There may be additional marking, which relates to the logo, the lot trace code information, or the environmental category on the device.

(5) Multiple Device Markings will be inside parentheses. Only one Device Marking contained in parentheses and separated by a "~" will appear on a device. If a line is indented then it is a continuation of the previous line and the two combined represent the entire Device Marking for that device.

(6) Lead finish/Ball material - Orderable Devices may have multiple material finish options. Finish options are separated by a vertical ruled line. Lead finish/Ball material values may wrap to two lines if the finish value exceeds the maximum column width.

**Important Information and Disclaimer:**The information provided on this page represents TI's knowledge and belief as of the date that it is provided. TI bases its knowledge and belief on information provided by third parties, and makes no representation or warranty as to the accuracy of such information. Efforts are underway to better integrate information from third parties. TI has taken and continues to take reasonable steps to provide representative and accurate information but may not have conducted destructive testing or chemical analysis on incoming materials and chemicals. TI and TI suppliers consider certain information to be proprietary, and thus CAS numbers and other limited information may not be available for release.

In no event shall TI's liability arising out of such information exceed the total purchase price of the TI part(s) at issue in this document sold by TI to Customer on an annual basis.

**OTHER QUALIFIED VERSIONS OF TPS3809 :**

- Automotive : [TPS3809-Q1](#)
- Enhanced Product : [TPS3809-EP](#)

NOTE: Qualified Version Definitions:

- Automotive - Q100 devices qualified for high-reliability automotive applications targeting zero defects
- Enhanced Product - Supports Defense, Aerospace and Medical Applications

**TAPE AND REEL INFORMATION**

**QUADRANT ASSIGNMENTS FOR PIN 1 ORIENTATION IN TAPE**

\*All dimensions are nominal

Device	Package Type	Package Drawing	Pins	SPQ	Reel Diameter (mm)	Reel Width W1 (mm)	A0 (mm)	B0 (mm)	K0 (mm)	P1 (mm)	W (mm)	Pin1 Quadrant
TPS3809I50DBVR	SOT-23	DBV	3	3000	178.0	9.0	3.3	3.2	1.4	4.0	8.0	Q3
TPS3809I50DBVT	SOT-23	DBV	3	250	178.0	9.0	3.3	3.2	1.4	4.0	8.0	Q3
TPS3809J25DBVR	SOT-23	DBV	3	3000	178.0	9.0	3.3	3.2	1.4	4.0	8.0	Q3
TPS3809J25DBVT	SOT-23	DBV	3	250	178.0	9.0	3.3	3.2	1.4	4.0	8.0	Q3
TPS3809K33DBVR	SOT-23	DBV	3	3000	178.0	9.0	3.3	3.2	1.4	4.0	8.0	Q3
TPS3809K33DBVT	SOT-23	DBV	3	250	178.0	9.0	3.3	3.2	1.4	4.0	8.0	Q3
TPS3809L30DBVR	SOT-23	DBV	3	3000	178.0	9.0	3.3	3.2	1.4	4.0	8.0	Q3
TPS3809L30DBVT	SOT-23	DBV	3	250	178.0	9.0	3.3	3.2	1.4	4.0	8.0	Q3

**TAPE AND REEL BOX DIMENSIONS**

\*All dimensions are nominal

Device	Package Type	Package Drawing	Pins	SPQ	Length (mm)	Width (mm)	Height (mm)
TPS3809I50DBVR	SOT-23	DBV	3	3000	180.0	180.0	18.0
TPS3809I50DBVT	SOT-23	DBV	3	250	180.0	180.0	18.0
TPS3809J25DBVR	SOT-23	DBV	3	3000	180.0	180.0	18.0
TPS3809J25DBVT	SOT-23	DBV	3	250	180.0	180.0	18.0
TPS3809K33DBVR	SOT-23	DBV	3	3000	180.0	180.0	18.0
TPS3809K33DBVT	SOT-23	DBV	3	250	180.0	180.0	18.0
TPS3809L30DBVR	SOT-23	DBV	3	3000	180.0	180.0	18.0
TPS3809L30DBVT	SOT-23	DBV	3	250	180.0	180.0	18.0

DBV0003A



# PACKAGE OUTLINE

SOT-23 - 1.45 mm max height

SMALL OUTLINE TRANSISTOR

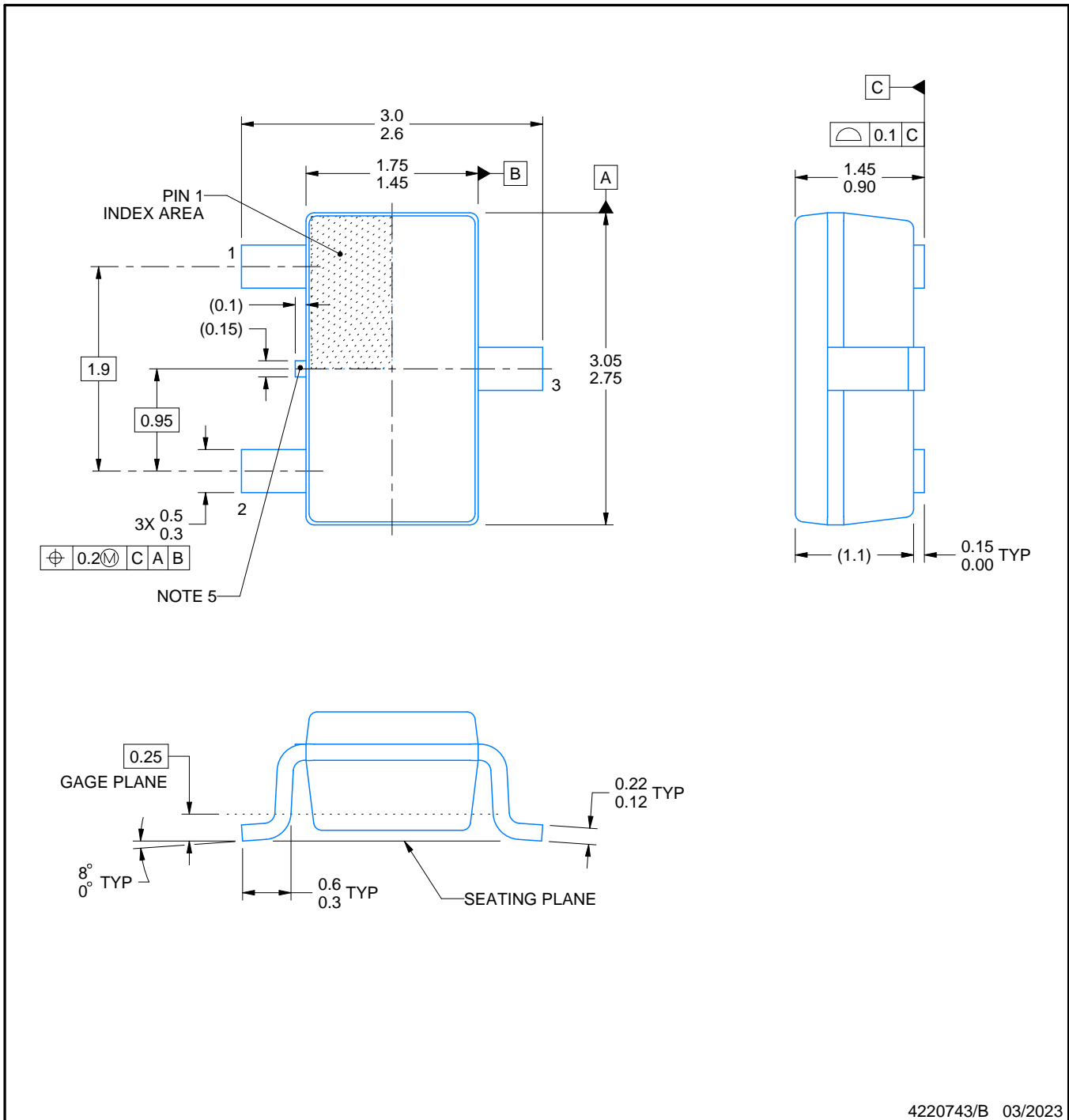

4220743/B 03/2023

## NOTES:

1. All linear dimensions are in millimeters. Any dimensions in parenthesis are for reference only. Dimensioning and tolerancing per ASME Y14.5M.
2. This drawing is subject to change without notice.
3. Reference JEDEC MO-178.
4. Body dimensions do not include mold flash, protrusions, or gate burrs. Mold flash, protrusions, or gate burrs shall not exceed 0.25 mm per side.
5. Support pin may differ or may not be present.

# EXAMPLE BOARD LAYOUT

DBV0003A

SOT-23 - 1.45 mm max height

SMALL OUTLINE TRANSISTOR

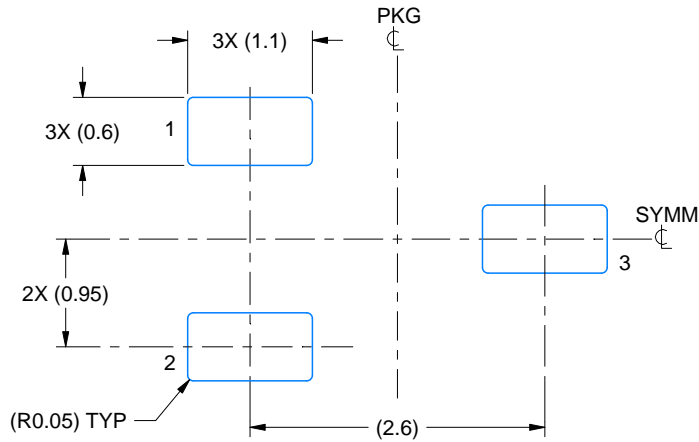

LAND PATTERN EXAMPLE  
EXPOSED METAL SHOWN  
SCALE:15X

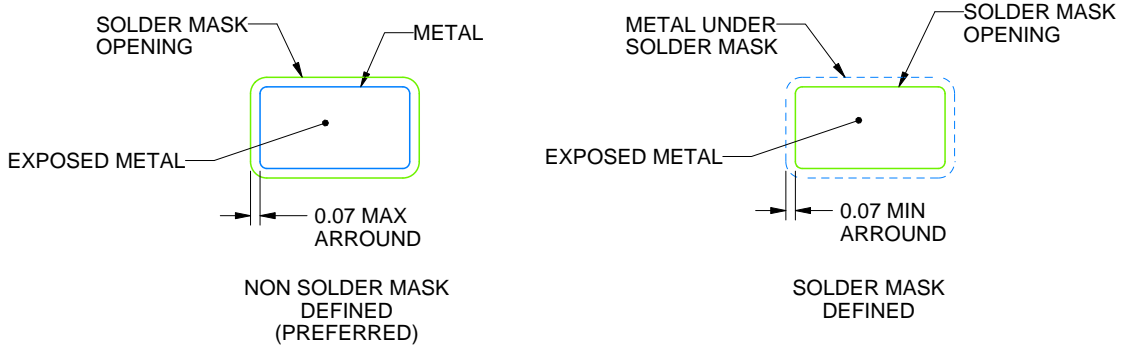

SOLDER MASK DETAILS

4220743/B 03/2023

NOTES: (continued)

- 6. Publication IPC-7351 may have alternate designs.
- 7. Solder mask tolerances between and around signal pads can vary based on board fabrication site.

# EXAMPLE STENCIL DESIGN

DBV0003A

SOT-23 - 1.45 mm max height

SMALL OUTLINE TRANSISTOR

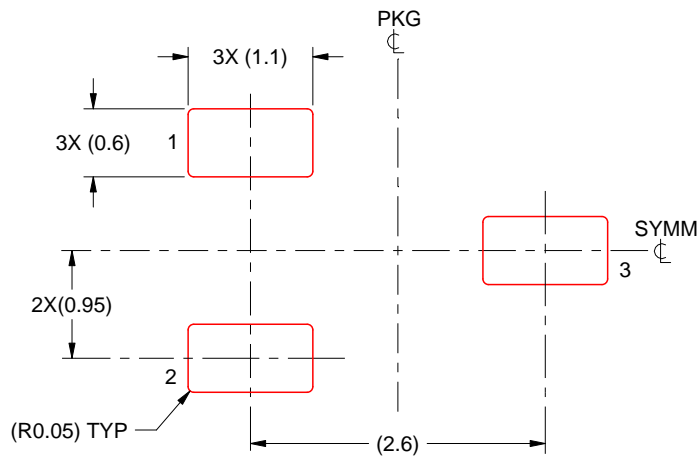

SOLDER PASTE EXAMPLE  
BASED ON 0.125 mm THICK STENCIL  
SCALE:15X

4220743/B 03/2023

NOTES: (continued)

8. Laser cutting apertures with trapezoidal walls and rounded corners may offer better paste release. IPC-7525 may have alternate design recommendations.
9. Board assembly site may have different recommendations for stencil design.

## IMPORTANT NOTICE AND DISCLAIMER

TI PROVIDES TECHNICAL AND RELIABILITY DATA (INCLUDING DATA SHEETS), DESIGN RESOURCES (INCLUDING REFERENCE DESIGNS), APPLICATION OR OTHER DESIGN ADVICE, WEB TOOLS, SAFETY INFORMATION, AND OTHER RESOURCES "AS IS" AND WITH ALL FAULTS, AND DISCLAIMS ALL WARRANTIES, EXPRESS AND IMPLIED, INCLUDING WITHOUT LIMITATION ANY IMPLIED WARRANTIES OF MERCHANTABILITY, FITNESS FOR A PARTICULAR PURPOSE OR NON-INFRINGEMENT OF THIRD PARTY INTELLECTUAL PROPERTY RIGHTS.

These resources are intended for skilled developers designing with TI products. You are solely responsible for (1) selecting the appropriate TI products for your application, (2) designing, validating and testing your application, and (3) ensuring your application meets applicable standards, and any other safety, security, regulatory or other requirements.

These resources are subject to change without notice. TI grants you permission to use these resources only for development of an application that uses the TI products described in the resource. Other reproduction and display of these resources is prohibited. No license is granted to any other TI intellectual property right or to any third party intellectual property right. TI disclaims responsibility for, and you will fully indemnify TI and its representatives against, any claims, damages, costs, losses, and liabilities arising out of your use of these resources.



TI's products are provided subject to [TI's Terms of Sale](#) or other applicable terms available either on [ti.com](https://www.ti.com) or provided in conjunction with such TI products. TI's provision of these resources does not expand or otherwise alter TI's applicable warranties or warranty disclaimers for TI products.

TI objects to and rejects any additional or different terms you may have proposed.







Mailing Address: Texas Instruments, Post Office Box 655303, Dallas, Texas 75265  
Copyright © 2023, Texas Instruments Incorporated

## Looking for pricing, stock, or lifecycle information?

Click below to explore more details on WIN SOURCE:

-  [View TPS3809L30DBVR on WIN SOURCE](#)
-  [Texas Instruments](#) Information

## Optimize Your Supply Chain with WIN SOURCE Solutions

-  Global Sourcing Solution
-  Obsolete Management
-  Cost Control Management
-  Shortage Management
-  Alternative Solution
-  Excess Inventory Management