



**THE DATASHEET OF
TPS3809K33DBVT**



3-Pin Supply Voltage Supervisors

 Check for Samples: [TPS3809J25](#), [TPS3809L30](#), [TPS3809K33](#), [TPS3809I50](#)

FEATURES

- 3-Pin SOT-23 Package
- Supply Current of 9 μ A (Typical)
- Precision Supply Voltage Monitor
2.5 V, 3 V, 3.3 V, 5 V
- Pin-For-Pin Compatible With MAX 809
- Temperature Range: -40°C to $+85^{\circ}\text{C}$

APPLICATIONS

- Applications Using DSPs, Microcontrollers, or Microprocessors
- Wireless Communication Systems
- Portable/Battery-Powered Equipment
- Programmable Controls
- Intelligent Instruments
- Industrial Equipment
- Notebook/Desktop Computers
- Automotive Systems

DESCRIPTION

The TPS3809 family of supervisory circuits provides circuit initialization and timing supervision, primarily for DSPs and processor-based systems.

During power-on, $\overline{\text{RESET}}$ is asserted when the supply voltage V_{DD} becomes higher than 1.1 V. Thereafter, the supervisory circuit monitors V_{DD} and keeps $\overline{\text{RESET}}$ active as long as V_{DD} remains below the threshold voltage V_{IT} . An internal timer delays the return of the output to the inactive state (high) to ensure proper system reset. The delay time, $t_{\text{d(typ)}}$ = 200 ms, starts after V_{DD} has risen above the threshold voltage V_{IT} . When the supply voltage drops below the threshold voltage V_{IT} , the output becomes active (low) again. No external components are required. All the devices of this family have a fixed sense-threshold voltage V_{IT} set by an internal voltage divider.

The product spectrum is designed for supply voltages of 2.5 V, 3 V, 3.3 V, and 5 V. The circuits are available in a 3-pin SOT-23. The TPS3809 devices are characterized for operation over a temperature range of -40°C to 85°C .

DBV PACKAGE
TOP VIEW)

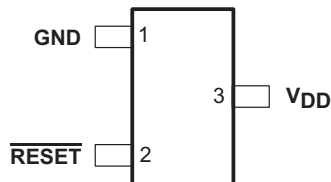

TYPICAL APPLICATION

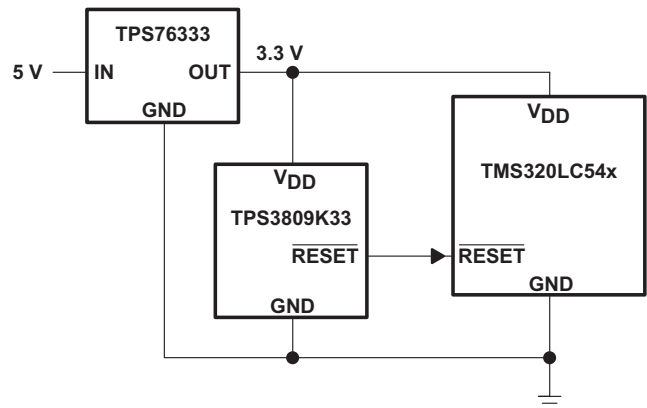

Please be aware that an important notice concerning availability, standard warranty, and use in critical applications of Texas Instruments semiconductor products and disclaimers thereto appears at the end of this data sheet.

All trademarks are the property of their respective owners.



These devices have limited built-in ESD protection. The leads should be shorted together or the device placed in conductive foam during storage or handling to prevent electrostatic damage to the MOS gates.

AVAILABLE OPTIONS⁽¹⁾

T _A	DEVICE NAME		THRESHOLD VOLTAGE	MARKING
–40°C to 85°C	TPS3809J25DBVR	TPS3809J25DBVT	2.25 V	PCZI
	TPS3809L30DBVR	TPS3809L30DBVT	2.64 V	PDAI
	TPS3809K33DBVR	TPS3809K33DBVT	2.93 V	PDBI
	TPS3809I50DBVR	TPS3809I50DBVT	4.55 V	PDCI

(1) For the most current package and ordering information, see the Package Option Addendum at the end of this data sheet, or visit the device product folder at www.ti.com.

FUNCTION/TRUTH TABLE, TPS3809

V _{DD} >V _{IT}	$\overline{\text{RESET}}$
0	L
1	H

ORDERING INFORMATION

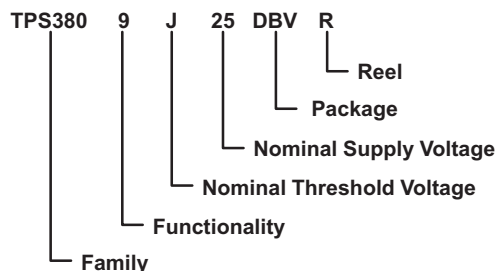

ABSOLUTE MAXIMUM RATINGS⁽¹⁾⁽²⁾

Over operating free-air temperature range (unless otherwise noted).

	UNIT
Supply voltage, V _{DD}	7 V
All other pins	–0.3 V to 7 V
Maximum low-output current, I _{OL}	5 mA
Maximum high-output current, I _{OH}	–5 mA
Input-clamp current, I _{IK} (V _I < 0 or V _I > V _{DD})	±20 mA
Output-clamp current, I _{OK} (V _O < 0 or V _O > V _{DD})	±20 mA
Continuous total power dissipation	See Dissipation Rating Table
Operating free-air temperature range, T _A	–40°C to 85°C
Storage temperature range, T _{stg}	–65°C to 150°C

- Stresses beyond those listed under *absolute maximum ratings* may cause permanent damage to the device. These are stress ratings only, and functional operation of the device at these or any other conditions beyond those indicated under *recommended operating conditions* is not implied. Exposure to absolute-maximum-rated conditions for extended periods may affect device reliability.
- All voltage values are with respect to GND. For reliable operation, the device should not be operated at 7 V for more than t = 1000h continuously.

DISSIPATION RATINGS

PACKAGE	T _A < 25°C POWER RATING	DERATING FACTOR ABOVE T _A < 25°C	T _A = 70°C POWER RATING	T _A = 85°C POWER RATING
DBV	437 mW	3.5 mW/°C	280 mW	227 mW

RECOMMENDED OPERATING CONDITIONS

	MIN	MAX	UNIT
Supply voltage, V _{DD}	2	6	V
$\overline{\text{RESET}}$ current sink during startup		50	μA
Operating free-air temperature range, T _A	–40	+85	°C

ELECTRICAL CHARACTERISTICS

Over recommended operating free-air temperature range (unless otherwise noted).

PARAMETER		TEST CONDITIONS	TPS3800-xx, TPS3801-xx, TPS3802-xx			UNIT	
			MIN	TYP	MAX		
V _{OH}	High-level output voltage	V _{DD} = 2.5 V to 6 V I _{OH} = -500 μA	V _{DD} - 0.2			V	
		V _{DD} = 3.3 V I _{OH} = -2 mA	V _{DD} - 0.4				
		V _{DD} = 6 V I _{OH} = -4 mA	V _{DD} - 0.4				
V _{OL}	Low-level output voltage	V _{DD} = 2 V to 6 V, I _{OL} = 500 μA	0.2			V	
		V _{DD} = 3.3 V, I _{OL} = 2 mA	0.4				
		V _{DD} = 6 V, I _{OL} = 4 mA	0.4				
Power-up reset voltage ⁽¹⁾		V _{DD} ≥ 1.1 V, I _{OL} = 50 μA	0.2			V	
V _{IT-}	Negative-going input threshold voltage ⁽²⁾	T _A = -40°C to 85°C	TPS3809J25	2.2	2.25	2.3	V
			TPS3809L30	2.58	2.64	2.7	
			TPS3809K33	2.87	2.93	2.99	
			TPS3809I50	4.45	4.55	4.65	
V _{hys}	Threshold hysteresis		TPS3809J25	30		mV	
			TPS3809L30	35			
			TPS3809K33	40			
			TPS3809I50	60			
I _{DD}	Supply current	V _{DD} = 2 V, output unconnected	9		12	μA	
		V _{DD} = 6 V, output unconnected	20		25		
C _i	Input capacitance	V _I = 0 V to V _{DD}	5			pF	

(1) The lowest supply voltage at which $\overline{\text{RESET}}$ becomes active. $t_r, V_{DD} \geq 15 \mu\text{s/V}$.

(2) To ensure the best stability of the threshold voltage, a bypass capacitor (0.1-μF ceramic) should be placed near the supply terminals.

TIMING REQUIREMENTS

at R_L = 1 MΩ, C_L = 50 pF, T_A = 25°C

PARAMETER		TEST CONDITIONS	MIN	TYP	MAX	UNIT	
t _w	Pulse width	at V _{DD}	V _{DD} = V _{IT-} + 0.2 V, V _{DD} = V _{IT-} - 0.2 V			3	μs

SWITCHING CHARACTERISTICS

at R_L = 1 MΩ, C_L = 50 pF, T_A = 25°C

PARAMETER		TEST CONDITIONS	MIN	TYP	MAX	UNIT
t _d	Delay time	V _{DD} ≥ V _{IT-} + 0.2 V, See timing diagram	120	200	280	ms
t _{PHL}	Propagation (delay) time, high-to-low-level output	V _{DD} to $\overline{\text{RESET}}$ delay V _{IL} = V _{IT-} - 0.2 V, V _{IH} = V _{IT-} + 0.2 V	1			μs

TIMING DIAGRAM

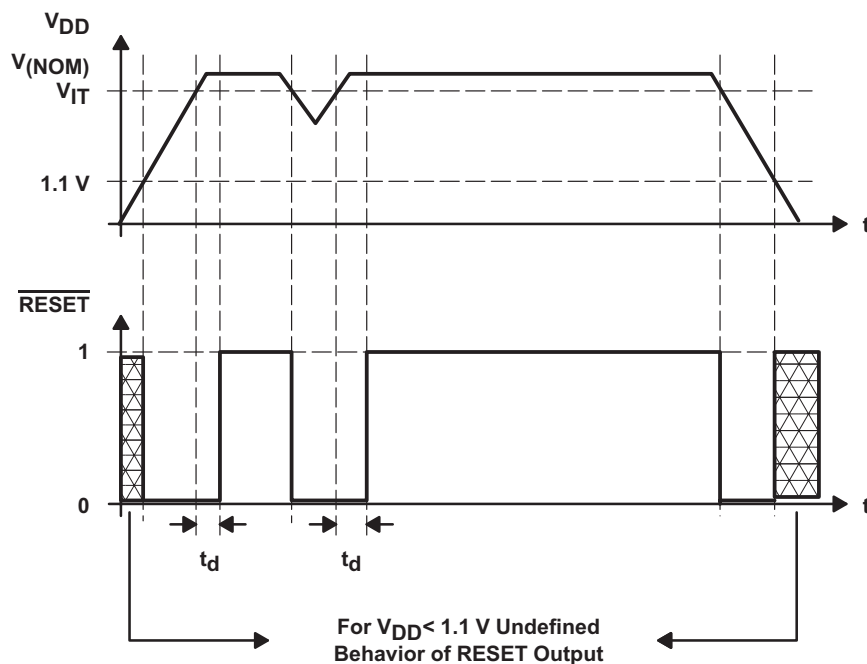

FUNCTIONAL BLOCK DIAGRAM

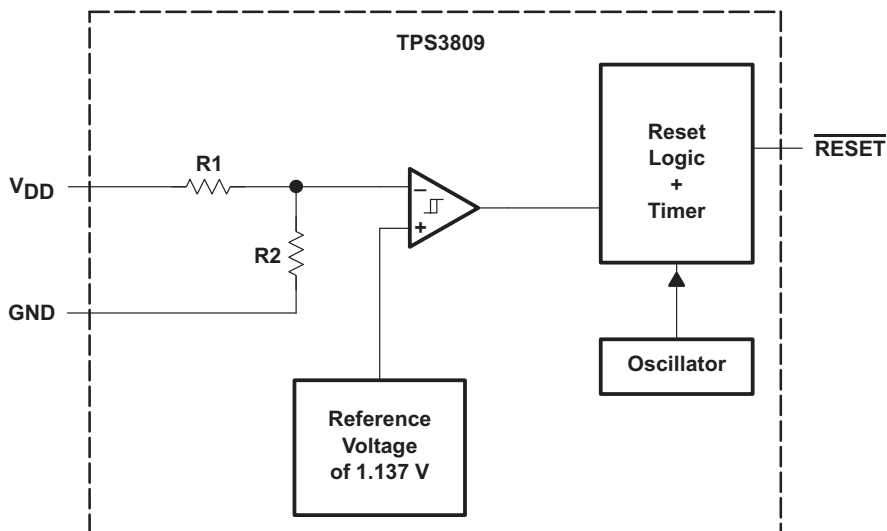

TYPICAL CHARACTERISTICS

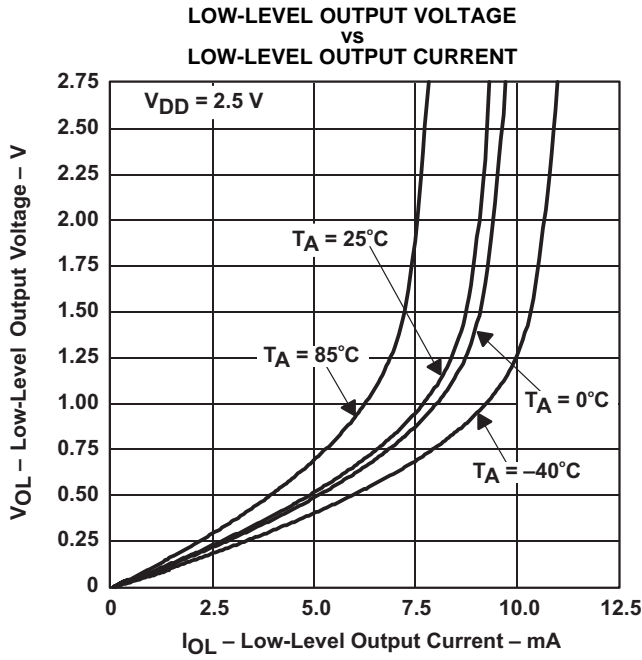

Figure 1.

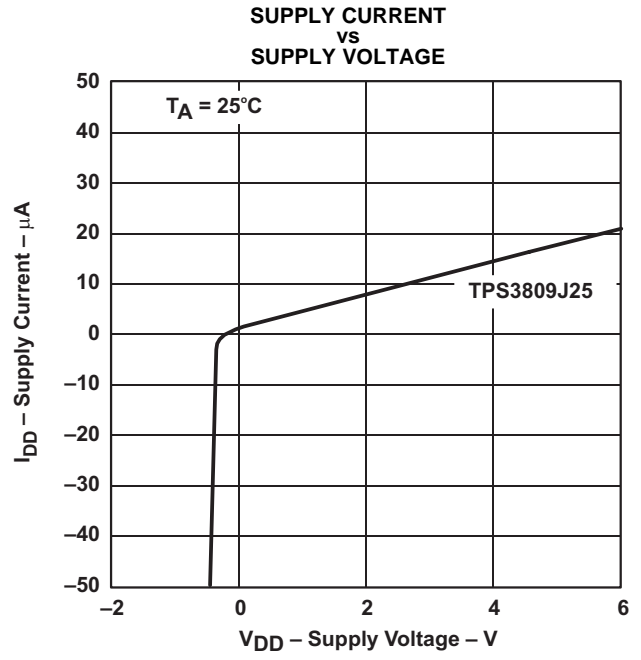

Figure 2.

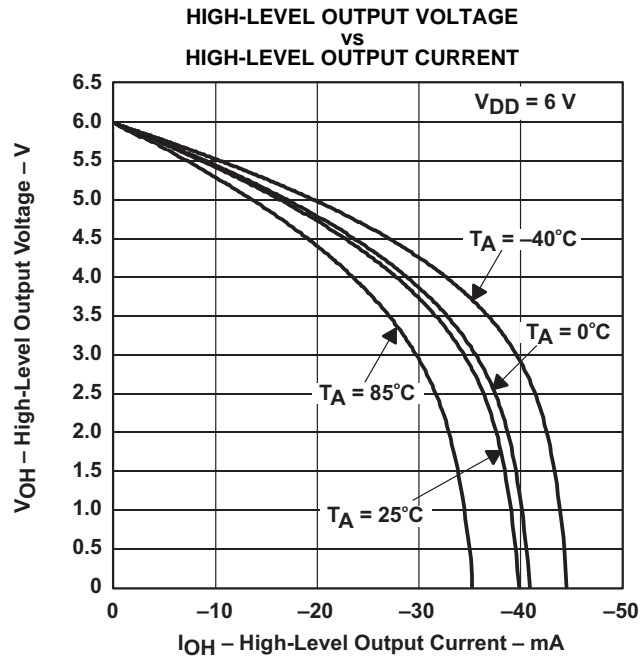

Figure 3.

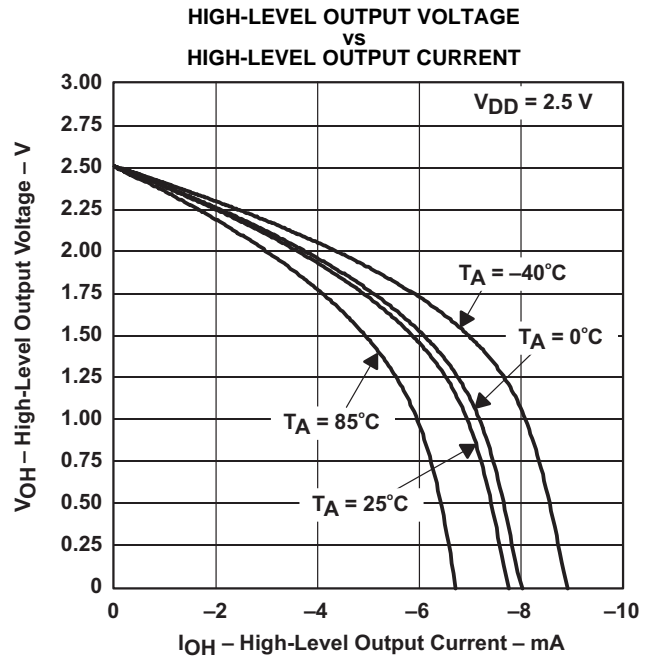

Figure 4.

TYPICAL CHARACTERISTICS (continued)

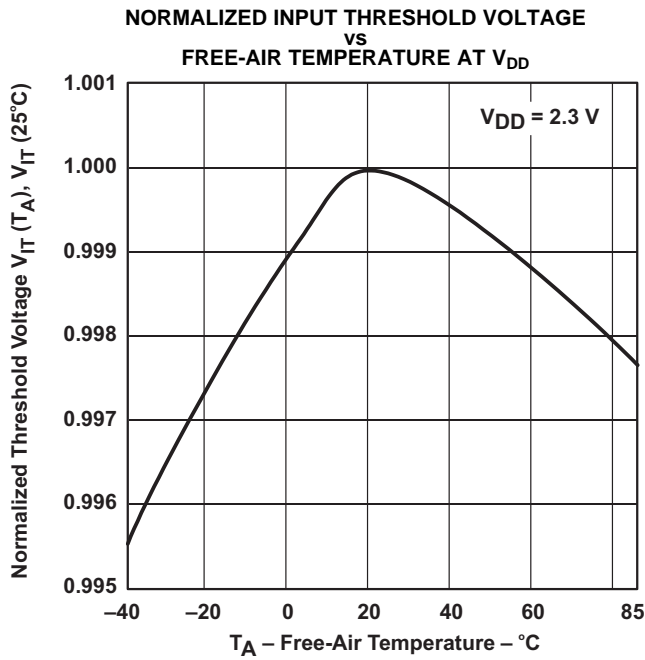

Figure 5.

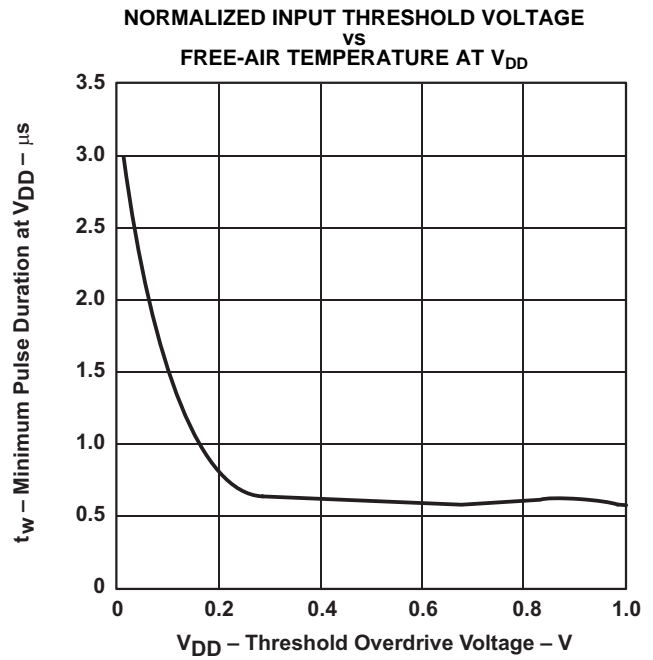

Figure 6.

REVISION HISTORY

NOTE: Page numbers for previous revisions may differ from page numbers in the current version.

Changes from Revision B (July 2012) to Revision C	Page
• Changed front page and page flow to match current standard look and feel	1
• Changed "Operating junction temperature range" to "Operating free-air temperature range" in Absolute Maximum Ratings (typo)	2
Changes from Revision A (October 2010) to Revision B	Page
• Changed the Pull-up resistor value, $\overline{\text{RESET}}$ To: $\overline{\text{RESET}}$ current sink during startup in the Recommended Operating Conditions Table	2
Changes from Original (August 1999) to Revision A	Page
• Added Pull-up resistor value, $\overline{\text{RESET}}$ to the Recommended Operating Conditions Table	2

PACKAGING INFORMATION

Orderable Device	Status (1)	Package Type	Package Drawing	Pins	Package Qty	Eco Plan (2)	Lead/Ball Finish (6)	MSL Peak Temp (3)	Op Temp (°C)	Device Marking (4/5)	Samples
TPS3809I50DBVR	ACTIVE	SOT-23	DBV	3	3000	Green (RoHS & no Sb/Br)	CU NIPDAU Call TI	Level-1-260C-UNLIM	-40 to 85	PDCI	Samples
TPS3809I50DBVRG4	ACTIVE	SOT-23	DBV	3	3000	Green (RoHS & no Sb/Br)	CU NIPDAU	Level-1-260C-UNLIM	-40 to 85	PDCI	Samples
TPS3809I50DBVT	ACTIVE	SOT-23	DBV	3	250	Green (RoHS & no Sb/Br)	CU NIPDAU Call TI	Level-1-260C-UNLIM	-40 to 85	PDCI	Samples
TPS3809J25DBVR	ACTIVE	SOT-23	DBV	3	3000	Green (RoHS & no Sb/Br)	CU NIPDAU	Level-1-260C-UNLIM	-40 to 85	PCZI	Samples
TPS3809J25DBVT	ACTIVE	SOT-23	DBV	3	250	Green (RoHS & no Sb/Br)	CU NIPDAU	Level-1-260C-UNLIM	-40 to 85	PCZI	Samples
TPS3809J25DBVTG4	ACTIVE	SOT-23	DBV	3	250	Green (RoHS & no Sb/Br)	CU NIPDAU	Level-1-260C-UNLIM	-40 to 85	PCZI	Samples
TPS3809K33DBVR	ACTIVE	SOT-23	DBV	3	3000	Green (RoHS & no Sb/Br)	CU NIPDAU	Level-1-260C-UNLIM	-40 to 85	PDBI	Samples
TPS3809K33DBVRG4	ACTIVE	SOT-23	DBV	3	3000	Green (RoHS & no Sb/Br)	CU NIPDAU	Level-1-260C-UNLIM	-40 to 85	PDBI	Samples
TPS3809K33DBVT	ACTIVE	SOT-23	DBV	3	250	Green (RoHS & no Sb/Br)	CU NIPDAU	Level-1-260C-UNLIM	-40 to 85	PDBI	Samples
TPS3809K33DBVTG4	ACTIVE	SOT-23	DBV	3	250	Green (RoHS & no Sb/Br)	CU NIPDAU	Level-1-260C-UNLIM	-40 to 85	PDBI	Samples
TPS3809L30DBVR	ACTIVE	SOT-23	DBV	3	3000	Green (RoHS & no Sb/Br)	CU NIPDAU	Level-1-260C-UNLIM	-40 to 85	PDAI	Samples
TPS3809L30DBVRG4	ACTIVE	SOT-23	DBV	3	3000	Green (RoHS & no Sb/Br)	CU NIPDAU	Level-1-260C-UNLIM	-40 to 85	PDAI	Samples
TPS3809L30DBVT	ACTIVE	SOT-23	DBV	3	250	Green (RoHS & no Sb/Br)	CU NIPDAU	Level-1-260C-UNLIM	-40 to 85	PDAI	Samples
TPS3809L30DBVTG4	ACTIVE	SOT-23	DBV	3	250	Green (RoHS & no Sb/Br)	CU NIPDAU	Level-1-260C-UNLIM	-40 to 85	PDAI	Samples

(1) The marketing status values are defined as follows:

ACTIVE: Product device recommended for new designs.

LIFEBUY: TI has announced that the device will be discontinued, and a lifetime-buy period is in effect.

NRND: Not recommended for new designs. Device is in production to support existing customers, but TI does not recommend using this part in a new design.

PREVIEW: Device has been announced but is not in production. Samples may or may not be available.

OBSOLETE: TI has discontinued the production of the device.

(2) **RoHS:** TI defines "RoHS" to mean semiconductor products that are compliant with the current EU RoHS requirements for all 10 RoHS substances, including the requirement that RoHS substance do not exceed 0.1% by weight in homogeneous materials. Where designed to be soldered at high temperatures, "RoHS" products are suitable for use in specified lead-free processes. TI may reference these types of products as "Pb-Free".

RoHS Exempt: TI defines "RoHS Exempt" to mean products that contain lead but are compliant with EU RoHS pursuant to a specific EU RoHS exemption.

Green: TI defines "Green" to mean the content of Chlorine (Cl) and Bromine (Br) based flame retardants meet JS709B low halogen requirements of ≤ 1000 ppm threshold. Antimony trioxide based flame retardants must also meet the ≤ 1000 ppm threshold requirement.

(3) **MSL, Peak Temp.** - The Moisture Sensitivity Level rating according to the JEDEC industry standard classifications, and peak solder temperature.

(4) There may be additional marking, which relates to the logo, the lot trace code information, or the environmental category on the device.

(5) Multiple Device Markings will be inside parentheses. Only one Device Marking contained in parentheses and separated by a "-" will appear on a device. If a line is indented then it is a continuation of the previous line and the two combined represent the entire Device Marking for that device.

(6) **Lead/Ball Finish** - Orderable Devices may have multiple material finish options. Finish options are separated by a vertical ruled line. Lead/Ball Finish values may wrap to two lines if the finish value exceeds the maximum column width.

Important Information and Disclaimer: The information provided on this page represents TI's knowledge and belief as of the date that it is provided. TI bases its knowledge and belief on information provided by third parties, and makes no representation or warranty as to the accuracy of such information. Efforts are underway to better integrate information from third parties. TI has taken and continues to take reasonable steps to provide representative and accurate information but may not have conducted destructive testing or chemical analysis on incoming materials and chemicals. TI and TI suppliers consider certain information to be proprietary, and thus CAS numbers and other limited information may not be available for release.

In no event shall TI's liability arising out of such information exceed the total purchase price of the TI part(s) at issue in this document sold by TI to Customer on an annual basis.

OTHER QUALIFIED VERSIONS OF TPS3809 :

- Automotive: [TPS3809-Q1](#)
- Enhanced Product: [TPS3809-EP](#)

NOTE: Qualified Version Definitions:

- Automotive - Q100 devices qualified for high-reliability automotive applications targeting zero defects
- Enhanced Product - Supports Defense, Aerospace and Medical Applications

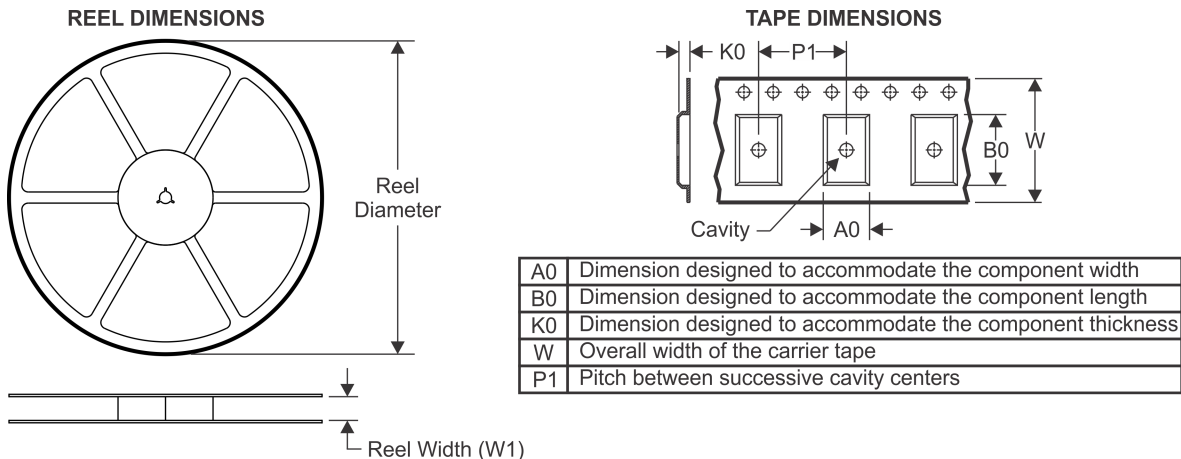
TAPE AND REEL INFORMATION

QUADRANT ASSIGNMENTS FOR PIN 1 ORIENTATION IN TAPE

*All dimensions are nominal

Device	Package Type	Package Drawing	Pins	SPQ	Reel Diameter (mm)	Reel Width W1 (mm)	A0 (mm)	B0 (mm)	K0 (mm)	P1 (mm)	W (mm)	Pin1 Quadrant
TPS3809I50DBVR	SOT-23	DBV	3	3000	178.0	9.0	3.3	3.2	1.47	4.0	8.0	Q3
TPS3809I50DBVT	SOT-23	DBV	3	250	178.0	9.0	3.3	3.2	1.47	4.0	8.0	Q3
TPS3809J25DBVR	SOT-23	DBV	3	3000	178.0	9.0	3.3	3.2	1.47	4.0	8.0	Q3
TPS3809J25DBVT	SOT-23	DBV	3	250	178.0	9.0	3.3	3.2	1.47	4.0	8.0	Q3
TPS3809K33DBVR	SOT-23	DBV	3	3000	178.0	9.0	3.3	3.2	1.47	4.0	8.0	Q3
TPS3809K33DBVT	SOT-23	DBV	3	250	178.0	9.0	3.3	3.2	1.47	4.0	8.0	Q3
TPS3809L30DBVR	SOT-23	DBV	3	3000	178.0	9.0	3.3	3.2	1.47	4.0	8.0	Q3
TPS3809L30DBVT	SOT-23	DBV	3	250	178.0	8.4	3.3	3.2	1.47	4.0	8.0	Q3

TAPE AND REEL BOX DIMENSIONS

*All dimensions are nominal

Device	Package Type	Package Drawing	Pins	SPQ	Length (mm)	Width (mm)	Height (mm)
TPS3809I50DBVR	SOT-23	DBV	3	3000	180.0	180.0	18.0
TPS3809I50DBVT	SOT-23	DBV	3	250	180.0	180.0	18.0
TPS3809J25DBVR	SOT-23	DBV	3	3000	180.0	180.0	18.0
TPS3809J25DBVT	SOT-23	DBV	3	250	180.0	180.0	18.0
TPS3809K33DBVR	SOT-23	DBV	3	3000	180.0	180.0	18.0
TPS3809K33DBVT	SOT-23	DBV	3	250	180.0	180.0	18.0
TPS3809L30DBVR	SOT-23	DBV	3	3000	180.0	180.0	18.0
TPS3809L30DBVT	SOT-23	DBV	3	250	180.0	180.0	18.0

DBV (R-PDSO-G3)

PLASTIC SMALL-OUTLINE PACKAGE

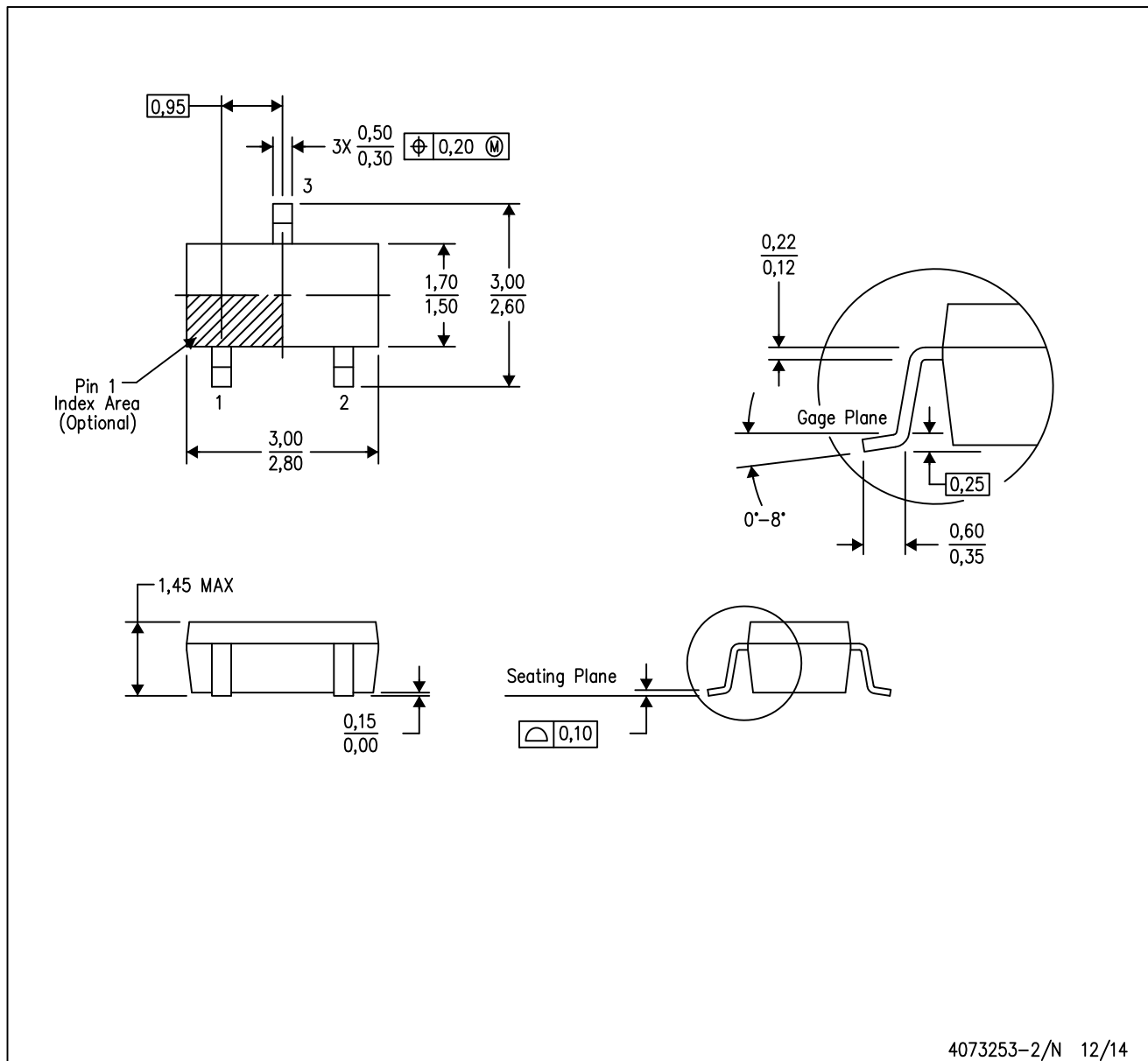

- NOTES:
- All linear dimensions are in millimeters.
 - This drawing is subject to change without notice.
 - Body dimensions do not include mold flash or protrusion. Mold flash and protrusion shall not exceed 0.15 per side.

DBV (R-PDSO-G3)

PLASTIC SMALL OUTLINE

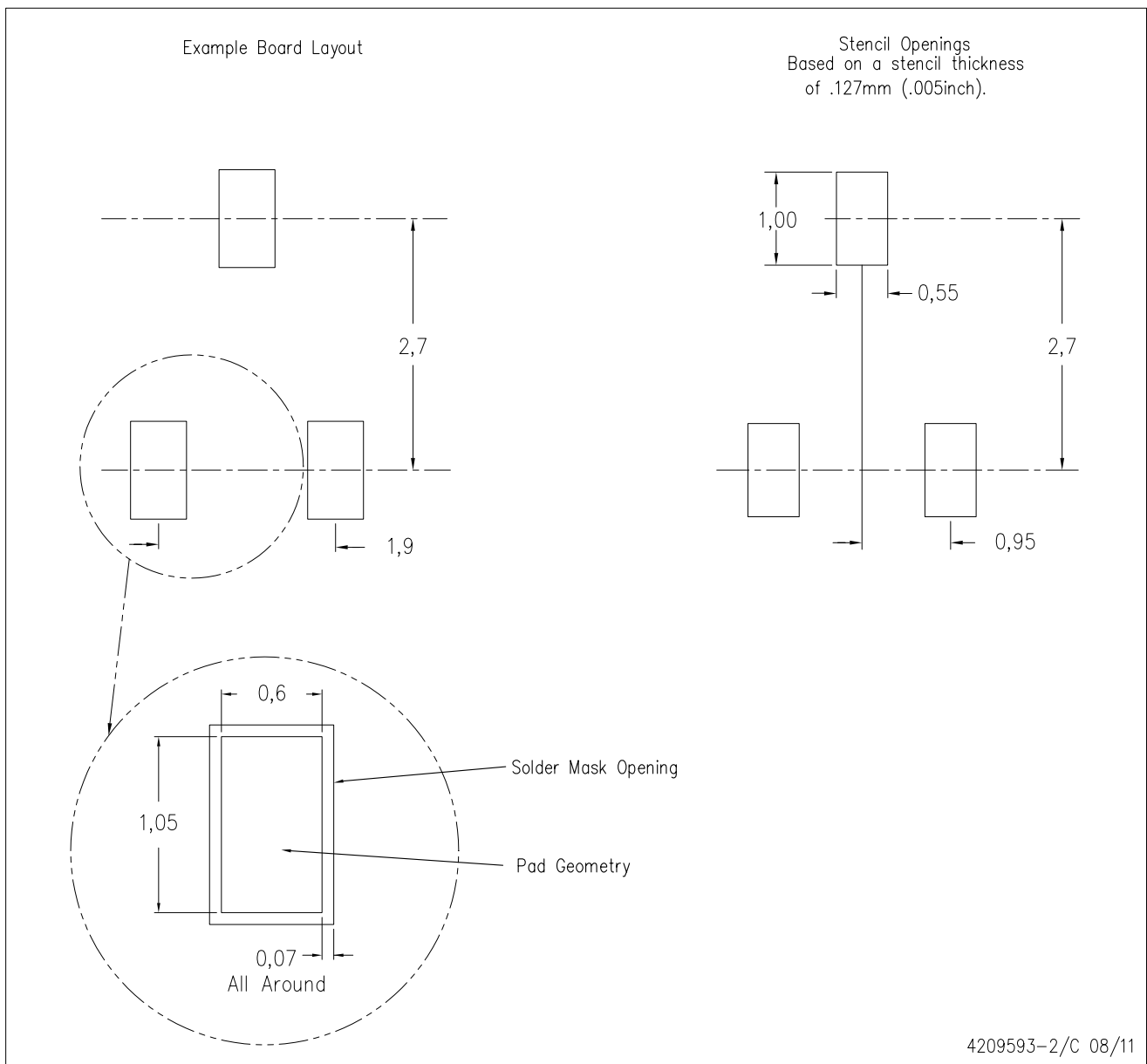

- NOTES:
- A. All linear dimensions are in millimeters.
 - B. This drawing is subject to change without notice.
 - C. Customers should place a note on the circuit board fabrication drawing not to alter the center solder mask defined pad.
 - D. Publication IPC-7351 is recommended for alternate designs.
 - E. Laser cutting apertures with trapezoidal walls and also rounding corners will offer better paste release. Customers should contact their board assembly site for stencil design recommendations. Example stencil design based on a 50% volumetric metal load solder paste. Refer to IPC-7525 for other stencil recommendations.

IMPORTANT NOTICE AND DISCLAIMER

TI PROVIDES TECHNICAL AND RELIABILITY DATA (INCLUDING DATASHEETS), DESIGN RESOURCES (INCLUDING REFERENCE DESIGNS), APPLICATION OR OTHER DESIGN ADVICE, WEB TOOLS, SAFETY INFORMATION, AND OTHER RESOURCES "AS IS" AND WITH ALL FAULTS, AND DISCLAIMS ALL WARRANTIES, EXPRESS AND IMPLIED, INCLUDING WITHOUT LIMITATION ANY IMPLIED WARRANTIES OF MERCHANTABILITY, FITNESS FOR A PARTICULAR PURPOSE OR NON-INFRINGEMENT OF THIRD PARTY INTELLECTUAL PROPERTY RIGHTS.

These resources are intended for skilled developers designing with TI products. You are solely responsible for (1) selecting the appropriate TI products for your application, (2) designing, validating and testing your application, and (3) ensuring your application meets applicable standards, and any other safety, security, or other requirements. These resources are subject to change without notice. TI grants you permission to use these resources only for development of an application that uses the TI products described in the resource. Other reproduction and display of these resources is prohibited. No license is granted to any other TI intellectual property right or to any third party intellectual property right. TI disclaims responsibility for, and you will fully indemnify TI and its representatives against, any claims, damages, costs, losses, and liabilities arising out of your use of these resources.

TI's products are provided subject to TI's Terms of Sale (www.ti.com/legal/termsofsale.html) or other applicable terms available either on ti.com or provided in conjunction with such TI products. TI's provision of these resources does not expand or otherwise alter TI's applicable warranties or warranty disclaimers for TI products.

Mailing Address: Texas Instruments, Post Office Box 655303, Dallas, Texas 75265
Copyright © 2019, Texas Instruments Incorporated

Looking for pricing, stock, or lifecycle information?

Click below to explore more details on WIN SOURCE:

 [View TPS3809K33DBVT on WIN SOURCE](#)

 [Texas Instruments](#) Information

Optimize Your Supply Chain with WIN SOURCE Solutions

-  Global Sourcing Solution
-  Obsolete Management
-  Cost Control Management
-  Shortage Management
-  Alternative Solution
-  Excess Inventory Management