



**THE DATASHEET OF
TPS3306-15DGKRG4**



DUAL PROCESSOR SUPERVISORY CIRCUITS WITH POWER-FAIL

FEATURES

- Dual Supervisory Circuits With Power-Fail for DSP and Processor-Based Systems
- Voltage Monitor for Power-Fail or Low-Battery Warning
- Watchdog Timer With 0.8 Second Time-Out
- Power-On Reset Generator With Integrated 100 ms Delay Time
- Open-Drain Reset and Power-Fail Output
- Supply Current of 15 μ A (Typ.)
- Supply Voltage Range: 7 V to 6 V
- Defined $\overline{\text{RESET}}$ Output From $V_{\text{DD}} \geq 1.1$ V
- MSOP-8 and SO-8 Packages
- Temperature Range: -40°C to $+85^{\circ}\text{C}$

APPLICATIONS

- Multivoltage DSPs and Processors
- Portable Battery-Powered Equipment
- Embedded Control Systems
- Intelligent Instruments
- Automotive Systems

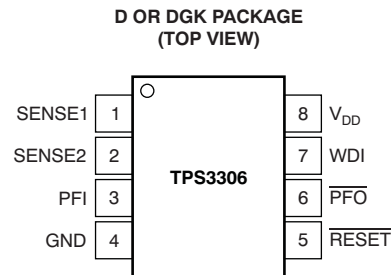

DESCRIPTION

The TPS3306 family is a series of supervisory circuits designed for circuit initialization which require two supply voltages, primarily in DSP and processor-based systems.

The product spectrum of the TPS3306-xx is designed for monitoring two independent supply voltages of 3.3 V/1.5 V, 3.3 V/1.8 V, 3.3 V/2 V, 3.3 V/2.5 V, or 3.3 V/5 V.

TYPICAL OPERATING CIRCUIT

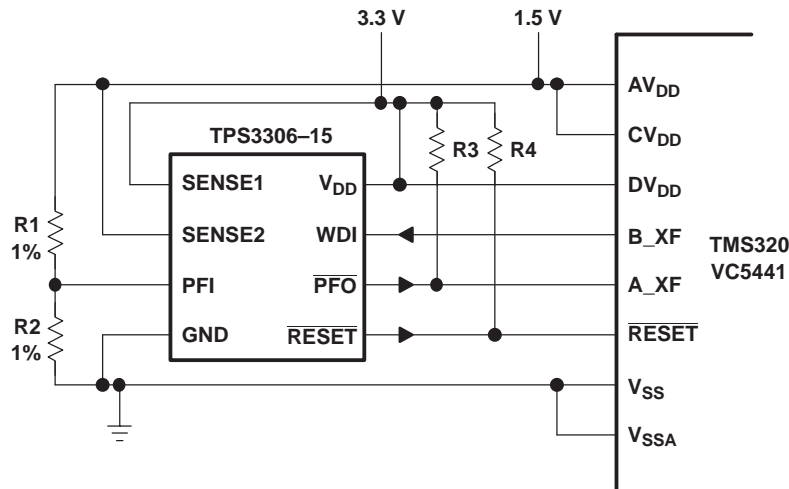

Please be aware that an important notice concerning availability, standard warranty, and use in critical applications of Texas Instruments semiconductor products and disclaimers thereto appears at the end of this data sheet.

All trademarks are the property of their respective owners.



This integrated circuit can be damaged by ESD. Texas Instruments recommends that all integrated circuits be handled with appropriate precautions. Failure to observe proper handling and installation procedures can cause damage.

ESD damage can range from subtle performance degradation to complete device failure. Precision integrated circuits may be more susceptible to damage because very small parametric changes could cause the device not to meet its published specifications.

AVAILABLE OPTIONS

Table 1. SUPPLY VOLTAGE MONITORING

DEVICE	NOMINAL SUPERVISED VOLTAGE		THRESHOLD VOLTAGE (TYP)	
	SENSE1	SENSE2	SENSE1	SENSE2
TPS3306-15	3.3 V	1.5 V	2.93 V	1.4 V
TPS3306-18	3.3 V	1.8 V	2.93 V	1.68 V
TPS3306-20	3.3 V	2 V	2.93 V	1.85 V
TPS3306-25	3.3 V	2.5 V	2.93 V	2.25 V
TPS3306-33	5 V	3.3 V	4.55 V	2.93 V

For the most current package and ordering information, see the Package Option Addendum at the end of this document, or see the TI website at www.ti.com.

DESCRIPTION (CONTINUED)

The various supervisory circuits are designed to monitor the nominal supply voltage, as shown in the [Supply Voltage Monitoring](#) table.

During power-on, $\overline{\text{RESET}}$ is asserted when the supply voltage V_{DD} becomes higher than 1.1 V. Thereafter, the supervisory circuits monitor the SENSEn inputs and keep $\overline{\text{RESET}}$ active as long as SENSEn remains below the threshold voltage V_{IT} .

An internal timer delays the return of the $\overline{\text{RESET}}$ output to the inactive state (high) to ensure proper system reset. The delay time, $t_{\text{d(typ)}} = 100$ ms, starts after SENSE1 and SENSE2 inputs have risen above the threshold voltage V_{IT} . When the voltage at SENSE1 or SENSE2 input drops below the threshold voltage V_{IT} , the output becomes active (low) again.

The integrated power-fail (PFI) comparator with separate open-drain ($\overline{\text{PFO}}$) output can be used for low-battery detection, power-fail warning, or for monitoring a power supply other than the main supply.

The TPS3306-xx devices integrate a watchdog timer that is periodically triggered by a positive or negative transition of WDI. When the supervising system fails to retrigger the watchdog circuit within the time-out interval, $t_{\text{(out)}} = 0.50$ s, $\overline{\text{RESET}}$ becomes active for the time period t_{d} . This event also reinitializes the watchdog timer. Leaving WDI unconnected disables the watchdog.

The TPS3306-xx devices are available in either 8-pin MSOP or standard 8-pin SO packages, and are characterized for operation over a temperature range of -40°C to $+85^{\circ}\text{C}$.

FUNCTION/TRUTH TABLES

SENSE1 > V _{IT1}	SENSE2 > V _{IT2}	$\overline{\text{RESET}}$
0	0	L
0	1	L
1	0	L
1	1	H

FUNCTION/TRUTH TABLES

PFI > V _{IT}	$\overline{\text{PFO}}$
0	L
1	H

FUNCTIONAL BLOCK DIAGRAM

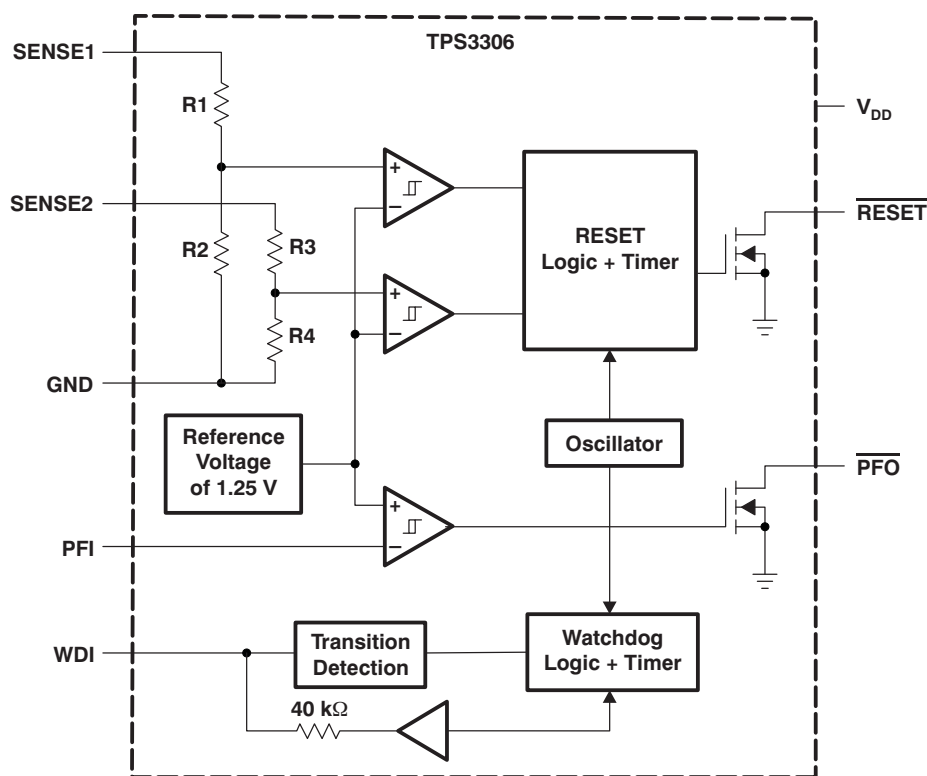

TIMING DIAGRAM

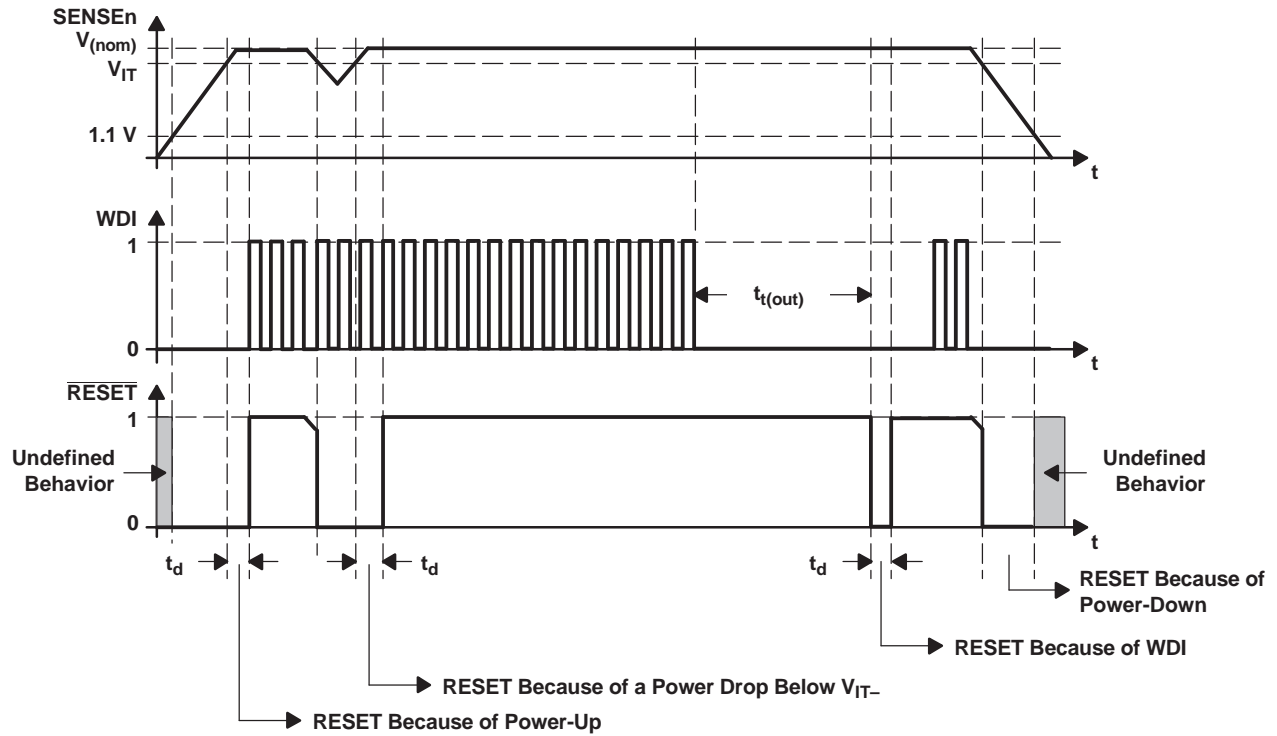

Table 4. Terminal Functions

TERMINAL NAME	NO.	I/O	DESCRIPTION
GND	4	I	Ground
PFI	3	I	Power-fail comparator input
PFO	6	O	Power-fail comparator output, open-drain
RESET	5	O	Active-low reset output, open-drain
SENSE1	1	I	Sense voltage input 1
SENSE2	2	I	Sense voltage input 2
WDI	7	I	Watchdog timer input
V _{DD}	8	I	Supply voltage

DETAILED DESCRIPTION

Watchdog

In a microprocessor- or DSP-based system, it is not only important to supervise the supply voltage, it is also important to ensure correct program execution. The task of a watchdog is to ensure that the program is not stalled in an indefinite loop. The microprocessor, microcontroller, or DSP typically has to toggle the watchdog input within 0.8 s to avoid a time-out occurring. Either a low-to-high or a high-to-low transition resets the internal watchdog timer. If the input is unconnected or tied with a high impedance driver, the watchdog is disabled and will be retrigged internally.

DETAILED DESCRIPTION (continued)

Saving Current While Using the Watchdog

The watchdog input is internally driven low during the first 7/8 of the watchdog time-out period, then momentarily pulses high, resetting the watchdog counter. For minimum watchdog input current (minimum overall power consumption), leave WDI low for the majority of the watchdog time-out period, pulsing it low-high-low once within 7/8 of the watchdog time-out period to reset the watchdog timer. If instead WDI is externally driven high for the majority of the time-out period, a current of $5\text{ V}/40\text{ k}\Omega = 125\text{ }\mu\text{A}$ can flow into WDI.

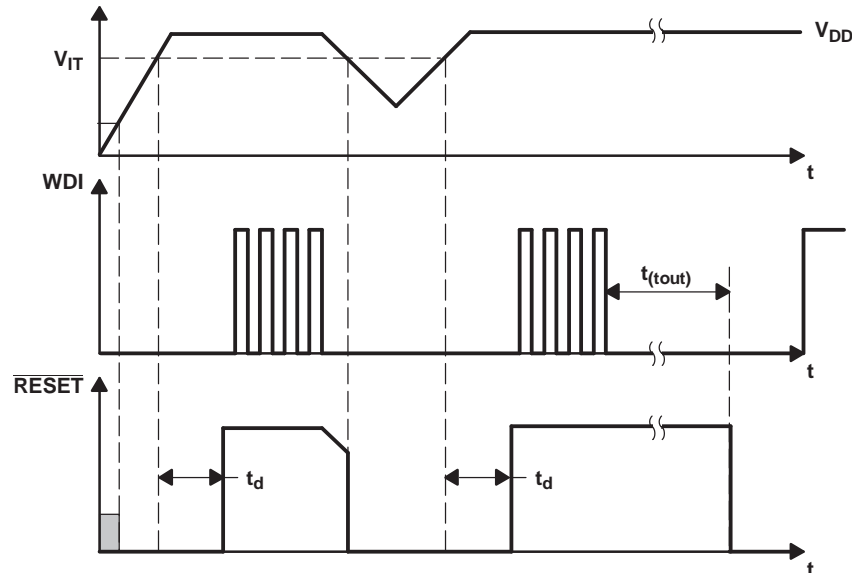
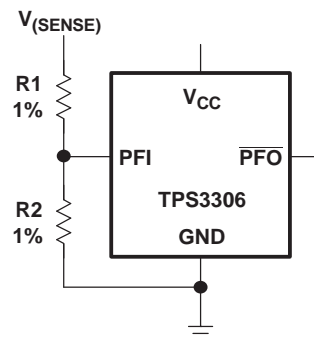

Figure 1. Watchdog Timing

Power-Fail Comparator (PFI and PFO)

An additional comparator is provided to monitor voltages other than the nominal supply voltage. The power-fail-input (PFI) will be compared with an internal voltage reference of 1.25 V. If the input voltage falls below the power-fail threshold (V_{PFI}) of typ. 1.25 V, the power-fail output (PFO) goes low. If it goes above 1.25 V plus about 10 mV hysteresis, the output returns to high. By connecting two external resistors, it is possible to supervise any voltages above 1.25 V. The sum of both resistors should be about 1 M Ω , to minimize power consumption and also to assure that the current in the PFI pin can be neglected compared with the current through the resistor network. The tolerance of the external resistors should be not more than 1% to ensure minimal variation of sensed voltage. If the power-fail comparator is unused, connect PFI to ground and leave PFO unconnected.



$$V_{PFI,trip} = 1.25\text{ V} \times \frac{R_1 + R_2}{R_2}$$

ABSOLUTE MAXIMUM RATINGS

Over operating free-air temperature range (unless otherwise noted).⁽¹⁾

	UNIT
Supply voltage, V_{DD} (see ⁽²⁾)	7 V
PFI pin	-0.3 V to $V_{DD} + 0.3$ V
All other pins (see ⁽²⁾)	-0.3 V to 7 V
Maximum low output current, I_{OL}	5 mA
Maximum high output current, I_{OH}	-5 mA
Input clamp current, I_{IK} ($V_I < 0$ or $V_I > V_{DD}$)	± 20 mA
Output clamp current, I_{OK} ($V_O < 0$ or $V_O > V_{DD}$)	± 20 mA
Continuous total power dissipation	See Dissipation Rating Table
Operating free-air temperature range, T_A	-40°C to +85°C
Storage temperature range, T_{stg}	-65°C to +150°C
Soldering temperature	260°C

- (1) Stresses beyond those listed under *absolute maximum ratings* may cause permanent damage to the device. These are stress ratings only, and functional operation of the device at these or any other conditions beyond those indicated under *recommended operating conditions* is not implied. Exposure to absolute-maximum-rated conditions for extended periods may affect device reliability.
- (2) All voltage values are with respect to GND. For reliable operation, the device must not be operated at 7 V for more than $t = 1000$ h continuously.

DISSIPATION RATING TABLE

PACKAGE	$T_A \leq +25^\circ\text{C}$ POWER RATING	DERATING FACTOR ABOVE $T_A = +25^\circ\text{C}$	$T_A = +70^\circ\text{C}$ POWER RATING	$T_A = +85^\circ\text{C}$ POWER RATING
DGK	424 mW	3.4 mW/°C	271 mW	220 mW
D	725 mW	5.8 mW/°C	464 mW	377 mW

RECOMMENDED OPERATING CONDITIONS

At specified temperature range.

	MIN	MAX	UNIT
Supply voltage, V_{DD}	2.7	6	V
Input voltage at WDI and PFI, V_I	0	$V_{DD} + 0.3$	V
Input voltage at SENSE1 and SENSE2, V_I	0	$(V_{DD} + 0.3)V_{IT}/1.25$ V	V
High-level input voltage at WDI, V_{IH}	$0.7 \times V_{DD}$		V
Low-level input voltage at WDI, V_{IL}		$0.3 \times V_{DD}$	V
Operating free-air temperature range, T_A	-40	+85	°C

ELECTRICAL CHARACTERISTICS

Over recommended operating free-air temperature range (unless otherwise noted).

PARAMETER		TEST CONDITIONS	MIN	TYP	MAX	UNIT		
V _{OL}	Low-level output voltage	RESET, PFO	V _{DD} = 2.7 V to 6 V, I _{OL} = 20 μA		0.2	V		
			V _{DD} = 3.3 V, I _{OL} = 2 mA		0.4			
			V _{DD} = 6 V, I _{OL} = 3 mA		0.4			
Power-up reset voltage (see ⁽¹⁾)		V _{DD} ≥ 1.1 V, I _{OL} = 20 μA			0.4	V		
V _{IT}	Negative-going input threshold voltage (see ⁽²⁾)	V _{SENSE1} , V _{SENSE2}	V _{DD} = 2.7 V to 6 V T _A = 0°C to +85°C	1.37	1.40	1.43	V	
				1.64	1.68	1.72		
				1.81	1.85	1.89		
				2.20	2.25	2.30		
				2.86	2.93	3		
				4.46	4.55	4.64		
	Negative-going input threshold voltage (see ⁽²⁾)	PFI	V _{SENSE1} , V _{SENSE2}	V _{DD} = 2.7 V to 6 V T _A = -40°C to +85°C	1.22	1.25	1.28	V
					1.37	1.40	1.44	
					1.64	1.68	1.73	
					1.81	1.85	1.90	
					2.20	2.25	2.32	
					2.86	2.93	3.02	
V _{hys}	Hysteresis	PFI	V _{IT} = 1.25 V		10	mV		
				V _{SENSEn}	V _{IT} = 1.40 V		15	
					V _{IT} = 1.68 V		15	
					V _{IT} = 1.86 V		20	
					V _{IT} = 2.25 V		20	
					V _{IT} = 2.93 V		30	
					V _{IT} = 4.55 V		40	
					I _{H(AV)}		Average high-level input current	WDI
I _{L(AV)}	Average low-level input current	WDI = 0 V, V _{DD} = 6 V, Time average (dc = 12%)	-15	-20				
			I _H	High-level input current	WDI	WDI = V _{DD} = 6 V	120	170
SENSE1	V _{SENSE1} = V _{DD} = 6 V	5					8	
		SENSE2					V _{SENSE2} = V _{DD} = 6 V	6
I _L	Low-level input current		WDI	WDI = 0 V, V _{DD} = 6 V	-120	-170		μA
I _I	Input current	PFI	V _{DD} = 6 V, 0 V ≤ V _I ≤ V _{DD}	-25	25	nA		
I _{DD}	Supply current			15	40	μA		
C _i	Input capacitance		V _I = 0 V to V _{DD}	10		pF		

(1) The lowest supply voltage at which RESET becomes active. t_r, V_{DD} ≥ 15 μs/V.

(2) To ensure best stability of the threshold voltage, a bypass capacitor (ceramic 0.1 μF) should be placed close to the supply terminals.

TIMING REQUIREMENTS

at $V_{DD} = 2.7\text{ V to }6\text{ V}$, $R_L = 1\text{ M}\Omega$, $C_L = 50\text{ pF}$, $T_A = 25^\circ\text{C}$

PARAMETER		TEST CONDITIONS	MIN	TYP	MAX	UNIT
t_w	Pulse width	SENSEn	$V_{\text{SENSEnL}} = V_{\text{IT}} - 0.2\text{ V}$, $V_{\text{SENSEnH}} = V_{\text{IT}} + 0.2\text{ V}$		6	μs
		WDI	$V_{\text{IH}} = 0.7 \times V_{\text{DD}}$, $V_{\text{IL}} = 0.3 \times V_{\text{DD}}$		100	ns

SWITCHING CHARACTERISTICS

at $V_{DD} = 2.7\text{ V to }6\text{ V}$, $R_L = 1\text{ M}\Omega$, $C_L = 50\text{ pF}$, $T_A = 25^\circ\text{C}$

PARAMETER		TEST CONDITIONS	MIN	TYP	MAX	UNIT
$t_{\text{t(out)}}$	Watchdog time-out	$V_{\text{I(SENSEn)}} \geq V_{\text{IT}} + 0.2\text{ V}$, See Timing Diagram	0.5	0.8	1.2	s
t_d	Delay time	$V_{\text{I(SENSEn)}} \geq V_{\text{IT}} + 0.2\text{ V}$, See Timing Diagram	70	100	140	ms
t_{PHL}	Propagation (delay) time, high-to-low level output	SENSEn to $\overline{\text{RESET}}$		1	5	μs
t_{PHL}	Propagation (delay) time, high-to-low level output	PFI to $\overline{\text{PFO}}$		0.5	1	μs
t_{PLH}	Propagation (delay) time, low-to-high level output					

TYPICAL CHARACTERISTICS

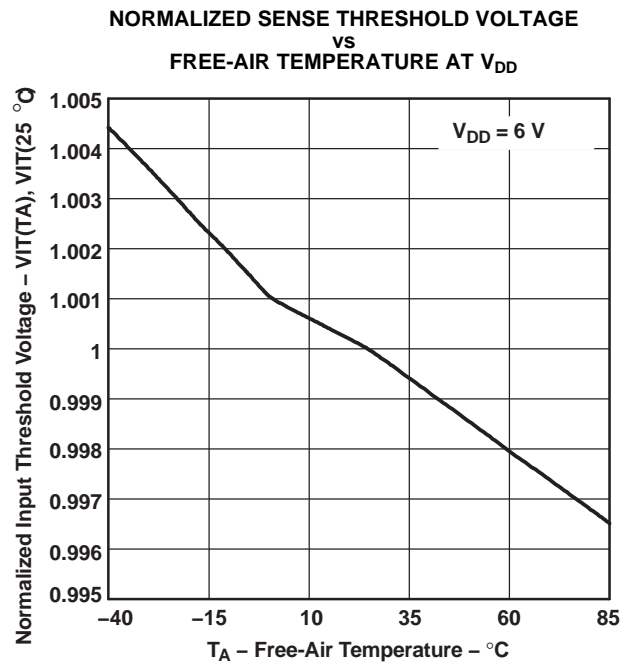

Figure 2.

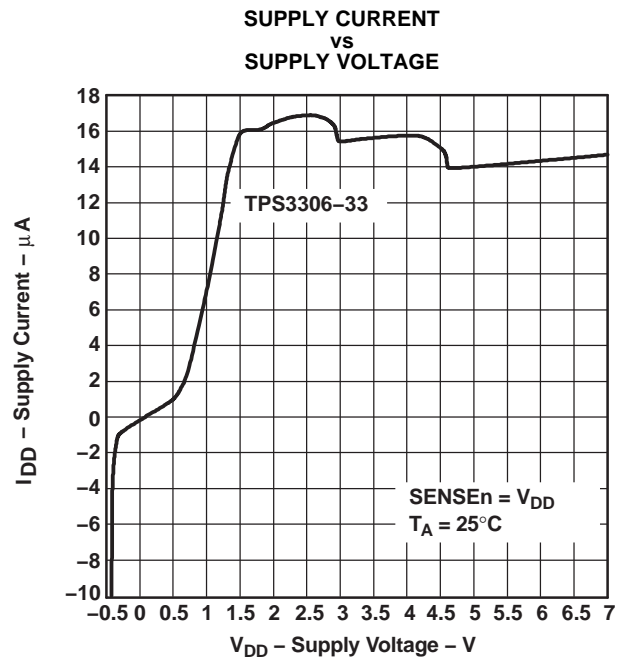

Figure 3.

TYPICAL CHARACTERISTICS (continued)

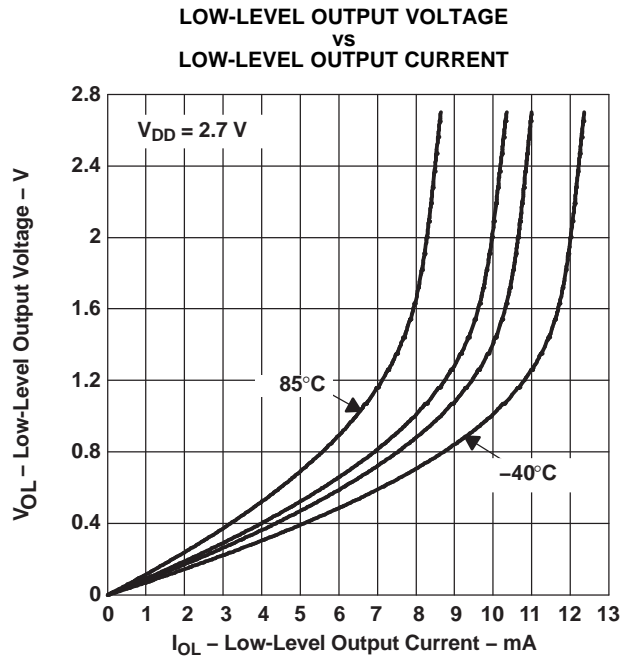

Figure 4.

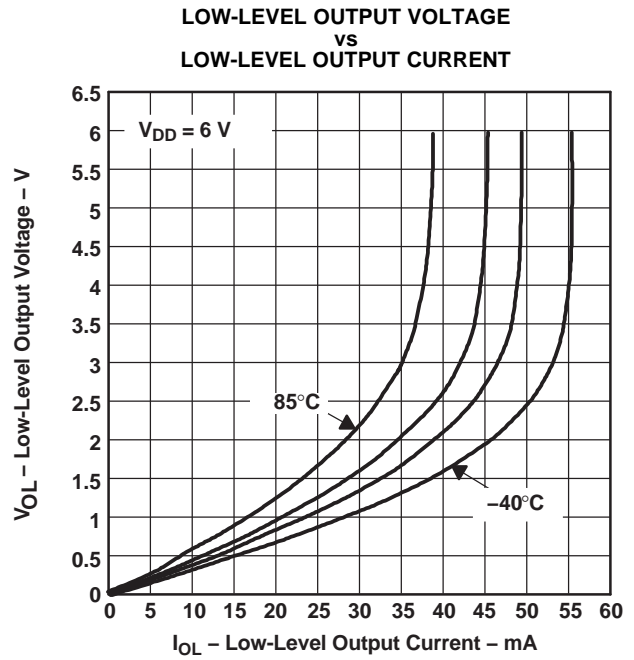

Figure 5.

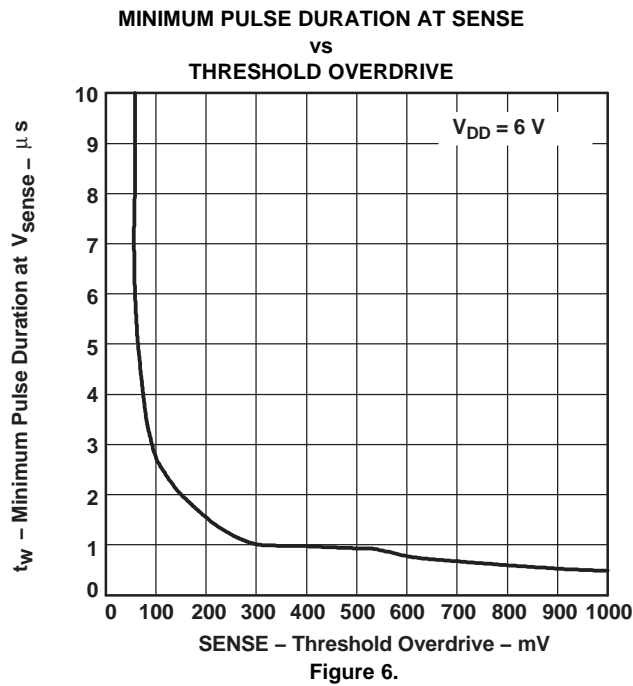

Figure 6.

PACKAGING INFORMATION

Orderable Device	Status (1)	Package Type	Package Drawing	Pins	Package Qty	Eco Plan (2)	Lead/Ball Finish (6)	MSL Peak Temp (3)	Op Temp (°C)	Device Marking (4/5)	Samples
TPS3306-15D	ACTIVE	SOIC	D	8	75	Green (RoHS & no Sb/Br)	CU NIPDAU	Level-1-260C-UNLIM	-40 to 85	30615	Samples
TPS3306-15DG4	ACTIVE	SOIC	D	8	75	Green (RoHS & no Sb/Br)	CU NIPDAU	Level-1-260C-UNLIM	-40 to 85	30615	Samples
TPS3306-15DGK	ACTIVE	VSSOP	DGK	8	80	Green (RoHS & no Sb/Br)	CU NIPDAU	Level-1-260C-UNLIM	-40 to 85	AIC	Samples
TPS3306-15DGKG4	ACTIVE	VSSOP	DGK	8	80	Green (RoHS & no Sb/Br)	CU NIPDAU	Level-1-260C-UNLIM	-40 to 85	AIC	Samples
TPS3306-15DGKR	ACTIVE	VSSOP	DGK	8	2500	Green (RoHS & no Sb/Br)	CU NIPDAU	Level-1-260C-UNLIM	-40 to 85	AIC	Samples
TPS3306-15DGKRG4	ACTIVE	VSSOP	DGK	8	2500	Green (RoHS & no Sb/Br)	CU NIPDAU	Level-1-260C-UNLIM	-40 to 85	AIC	Samples
TPS3306-15DR	ACTIVE	SOIC	D	8	2500	Green (RoHS & no Sb/Br)	CU NIPDAU	Level-1-260C-UNLIM	-40 to 85	30615	Samples
TPS3306-18D	ACTIVE	SOIC	D	8	75	Green (RoHS & no Sb/Br)	CU NIPDAU	Level-1-260C-UNLIM	-40 to 85	30618	Samples
TPS3306-18DG4	ACTIVE	SOIC	D	8	75	Green (RoHS & no Sb/Br)	CU NIPDAU	Level-1-260C-UNLIM	-40 to 85	30618	Samples
TPS3306-18DGK	ACTIVE	VSSOP	DGK	8	80	Green (RoHS & no Sb/Br)	CU NIPDAU	Level-1-260C-UNLIM	-40 to 85	AID	Samples
TPS3306-18DGKG4	ACTIVE	VSSOP	DGK	8	80	Green (RoHS & no Sb/Br)	CU NIPDAU	Level-1-260C-UNLIM	-40 to 85	AID	Samples
TPS3306-18DGKR	ACTIVE	VSSOP	DGK	8	2500	Green (RoHS & no Sb/Br)	CU NIPDAU	Level-1-260C-UNLIM	-40 to 85	AID	Samples
TPS3306-18DGKRG4	ACTIVE	VSSOP	DGK	8	2500	Green (RoHS & no Sb/Br)	CU NIPDAU	Level-1-260C-UNLIM	-40 to 85	AID	Samples
TPS3306-18DR	ACTIVE	SOIC	D	8	2500	Green (RoHS & no Sb/Br)	CU NIPDAU	Level-1-260C-UNLIM	-40 to 85	30618	Samples
TPS3306-20D	ACTIVE	SOIC	D	8	75	Green (RoHS & no Sb/Br)	CU NIPDAU	Level-1-260C-UNLIM	-40 to 85	30620	Samples
TPS3306-25D	ACTIVE	SOIC	D	8	75	Green (RoHS & no Sb/Br)	CU NIPDAU	Level-1-260C-UNLIM	-40 to 85	30625	Samples
TPS3306-25DGK	ACTIVE	VSSOP	DGK	8	80	Green (RoHS & no Sb/Br)	CU NIPDAU	Level-1-260C-UNLIM	-40 to 85	AIF	Samples

Orderable Device	Status (1)	Package Type	Package Drawing	Pins	Package Qty	Eco Plan (2)	Lead/Ball Finish (6)	MSL Peak Temp (3)	Op Temp (°C)	Device Marking (4/5)	Samples
TPS3306-25DGKG4	ACTIVE	VSSOP	DGK	8	80	Green (RoHS & no Sb/Br)	CU NIPDAU	Level-1-260C-UNLIM	-40 to 85	AIF	Samples
TPS3306-25DGKR	ACTIVE	VSSOP	DGK	8	2500	Green (RoHS & no Sb/Br)	CU NIPDAU	Level-1-260C-UNLIM	-40 to 85	AIF	Samples
TPS3306-25DGKRG4	ACTIVE	VSSOP	DGK	8	2500	Green (RoHS & no Sb/Br)	CU NIPDAU	Level-1-260C-UNLIM	-40 to 85	AIF	Samples
TPS3306-25DR	ACTIVE	SOIC	D	8	2500	Green (RoHS & no Sb/Br)	CU NIPDAU	Level-1-260C-UNLIM	-40 to 85	30625	Samples
TPS3306-33D	ACTIVE	SOIC	D	8	75	Green (RoHS & no Sb/Br)	CU NIPDAU	Level-1-260C-UNLIM	-40 to 85	30633	Samples
TPS3306-33DGK	ACTIVE	VSSOP	DGK	8	80	Green (RoHS & no Sb/Br)	CU NIPDAU	Level-1-260C-UNLIM	-40 to 85	AIG	Samples
TPS3306-33DGKR	ACTIVE	VSSOP	DGK	8	2500	Green (RoHS & no Sb/Br)	CU NIPDAU	Level-1-260C-UNLIM	-40 to 85	AIG	Samples
TPS3306-33DR	ACTIVE	SOIC	D	8	2500	Green (RoHS & no Sb/Br)	CU NIPDAU	Level-1-260C-UNLIM	-40 to 85	30633	Samples

(1) The marketing status values are defined as follows:

ACTIVE: Product device recommended for new designs.

LIFEBUY: TI has announced that the device will be discontinued, and a lifetime-buy period is in effect.

NRND: Not recommended for new designs. Device is in production to support existing customers, but TI does not recommend using this part in a new design.

PREVIEW: Device has been announced but is not in production. Samples may or may not be available.

OBSELETE: TI has discontinued the production of the device.

(2) **RoHS:** TI defines "RoHS" to mean semiconductor products that are compliant with the current EU RoHS requirements for all 10 RoHS substances, including the requirement that RoHS substance do not exceed 0.1% by weight in homogeneous materials. Where designed to be soldered at high temperatures, "RoHS" products are suitable for use in specified lead-free processes. TI may reference these types of products as "Pb-Free".

RoHS Exempt: TI defines "RoHS Exempt" to mean products that contain lead but are compliant with EU RoHS pursuant to a specific EU RoHS exemption.

Green: TI defines "Green" to mean the content of Chlorine (Cl) and Bromine (Br) based flame retardants meet JS709B low halogen requirements of <=1000ppm threshold. Antimony trioxide based flame retardants must also meet the <=1000ppm threshold requirement.

(3) MSL, Peak Temp. - The Moisture Sensitivity Level rating according to the JEDEC industry standard classifications, and peak solder temperature.

(4) There may be additional marking, which relates to the logo, the lot trace code information, or the environmental category on the device.

(5) Multiple Device Markings will be inside parentheses. Only one Device Marking contained in parentheses and separated by a "~" will appear on a device. If a line is indented then it is a continuation of the previous line and the two combined represent the entire Device Marking for that device.

⁽⁶⁾ Lead/Ball Finish - Orderable Devices may have multiple material finish options. Finish options are separated by a vertical ruled line. Lead/Ball Finish values may wrap to two lines if the finish value exceeds the maximum column width.

Important Information and Disclaimer:The information provided on this page represents TI's knowledge and belief as of the date that it is provided. TI bases its knowledge and belief on information provided by third parties, and makes no representation or warranty as to the accuracy of such information. Efforts are underway to better integrate information from third parties. TI has taken and continues to take reasonable steps to provide representative and accurate information but may not have conducted destructive testing or chemical analysis on incoming materials and chemicals. TI and TI suppliers consider certain information to be proprietary, and thus CAS numbers and other limited information may not be available for release.

In no event shall TI's liability arising out of such information exceed the total purchase price of the TI part(s) at issue in this document sold by TI to Customer on an annual basis.

OTHER QUALIFIED VERSIONS OF TPS3306 :

- Automotive: [TPS3306-Q1](#)

NOTE: Qualified Version Definitions:

- Automotive - Q100 devices qualified for high-reliability automotive applications targeting zero defects

TAPE AND REEL INFORMATION

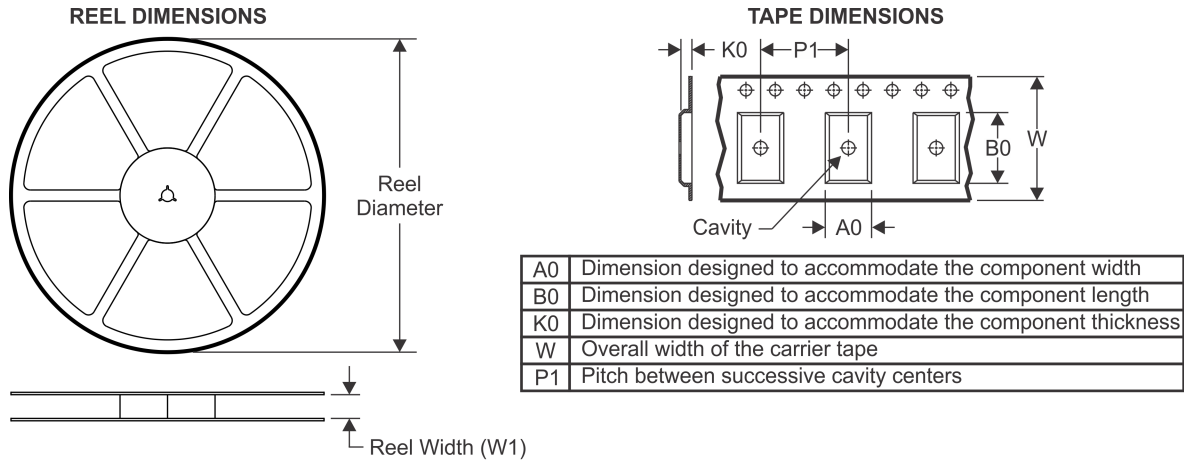

QUADRANT ASSIGNMENTS FOR PIN 1 ORIENTATION IN TAPE



*All dimensions are nominal

Device	Package Type	Package Drawing	Pins	SPQ	Reel Diameter (mm)	Reel Width W1 (mm)	A0 (mm)	B0 (mm)	K0 (mm)	P1 (mm)	W (mm)	Pin1 Quadrant
TPS3306-15DGKR	VSSOP	DGK	8	2500	330.0	12.4	5.3	3.4	1.4	8.0	12.0	Q1
TPS3306-15DR	SOIC	D	8	2500	330.0	12.4	6.4	5.2	2.1	8.0	12.0	Q1
TPS3306-18DGKR	VSSOP	DGK	8	2500	330.0	12.4	5.3	3.4	1.4	8.0	12.0	Q1
TPS3306-18DR	SOIC	D	8	2500	330.0	12.4	6.4	5.2	2.1	8.0	12.0	Q1
TPS3306-25DGKR	VSSOP	DGK	8	2500	330.0	12.4	5.3	3.4	1.4	8.0	12.0	Q1
TPS3306-25DR	SOIC	D	8	2500	330.0	12.4	6.4	5.2	2.1	8.0	12.0	Q1
TPS3306-33DGKR	VSSOP	DGK	8	2500	330.0	12.4	5.3	3.4	1.4	8.0	12.0	Q1
TPS3306-33DR	SOIC	D	8	2500	330.0	12.4	6.4	5.2	2.1	8.0	12.0	Q1

TAPE AND REEL BOX DIMENSIONS

*All dimensions are nominal

Device	Package Type	Package Drawing	Pins	SPQ	Length (mm)	Width (mm)	Height (mm)
TPS3306-15DGKR	VSSOP	DGK	8	2500	358.0	335.0	35.0
TPS3306-15DR	SOIC	D	8	2500	350.0	350.0	43.0
TPS3306-18DGKR	VSSOP	DGK	8	2500	358.0	335.0	35.0
TPS3306-18DR	SOIC	D	8	2500	350.0	350.0	43.0
TPS3306-25DGKR	VSSOP	DGK	8	2500	358.0	335.0	35.0
TPS3306-25DR	SOIC	D	8	2500	350.0	350.0	43.0
TPS3306-33DGKR	VSSOP	DGK	8	2500	358.0	335.0	35.0
TPS3306-33DR	SOIC	D	8	2500	350.0	350.0	43.0

DGK (S-PDSO-G8)

PLASTIC SMALL-OUTLINE PACKAGE

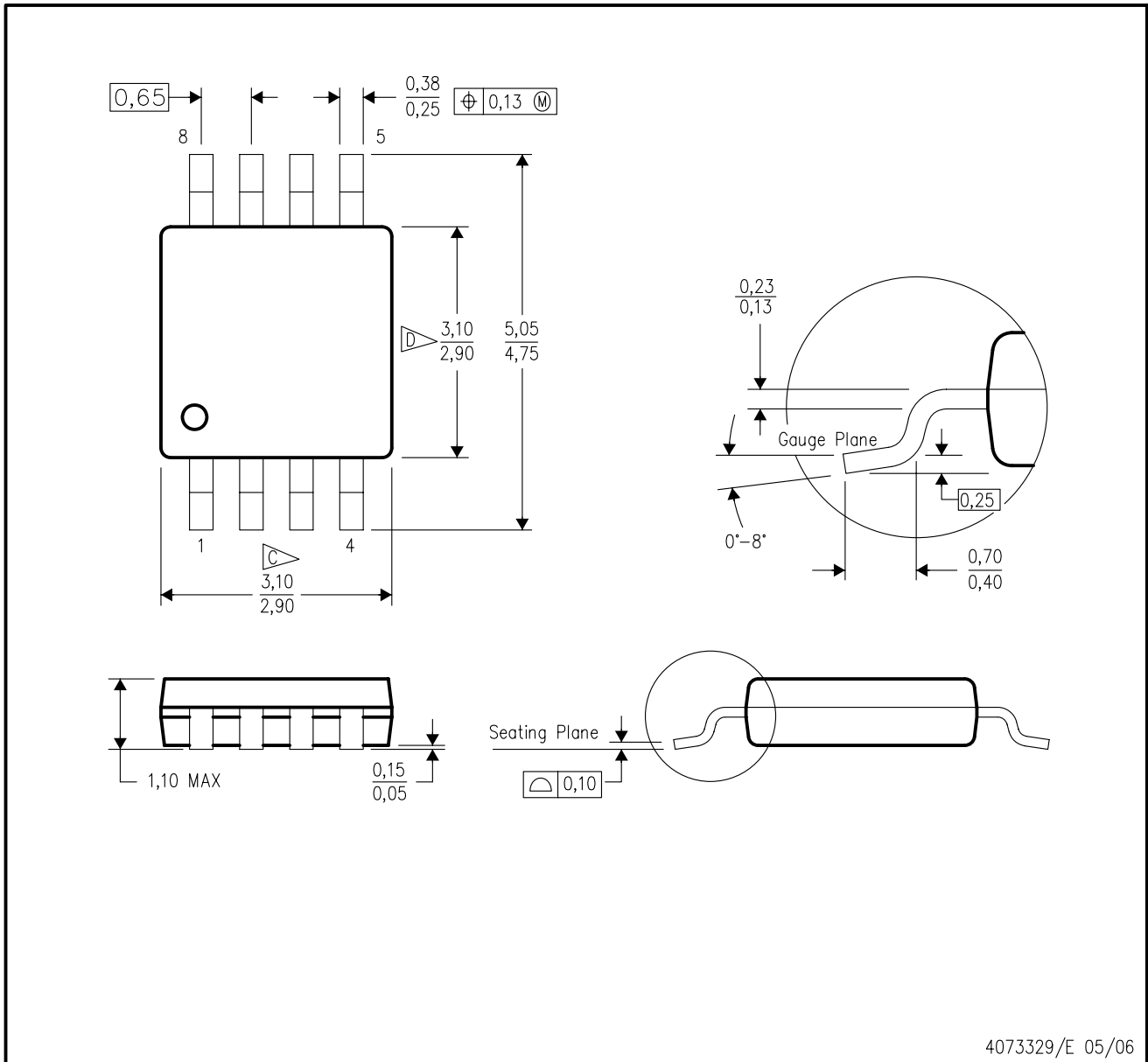

4073329/E 05/06

- NOTES:
- A. All linear dimensions are in millimeters.
 - B. This drawing is subject to change without notice.
 - C. Body length does not include mold flash, protrusions, or gate burrs. Mold flash, protrusions, or gate burrs shall not exceed 0.15 per end.
 - D. Body width does not include interlead flash. Interlead flash shall not exceed 0.50 per side.
 - E. Falls within JEDEC MO-187 variation AA, except interlead flash.

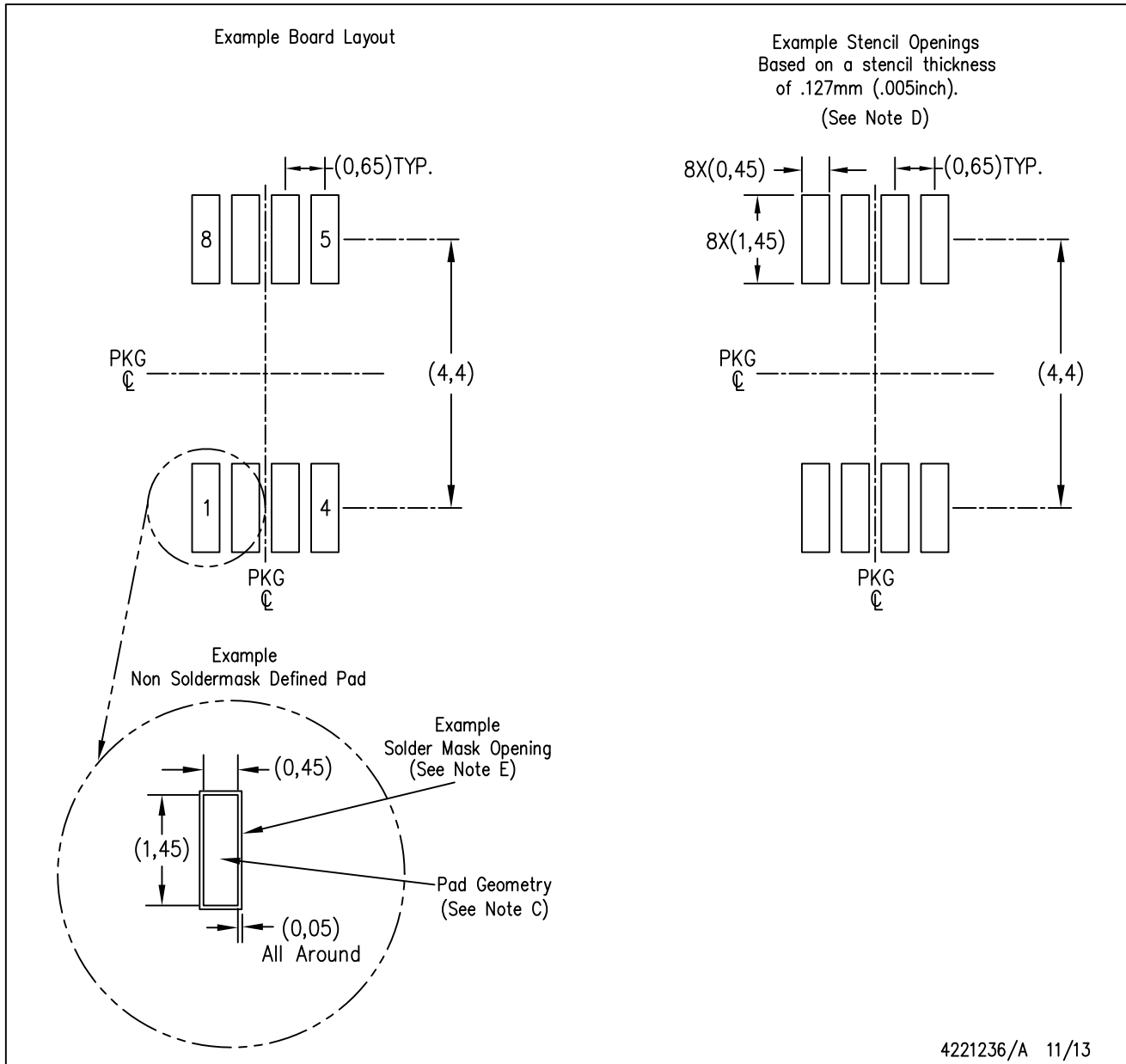

- NOTES:
- A. All linear dimensions are in millimeters.
 - B. This drawing is subject to change without notice.
 - C. Publication IPC-7351 is recommended for alternate designs.
 - D. Laser cutting apertures with trapezoidal walls and also rounding corners will offer better paste release. Customers should contact their board assembly site for stencil design recommendations. Refer to IPC-7525 for other stencil recommendations.
 - E. Customers should contact their board fabrication site for solder mask tolerances between and around signal pads.



D0008A

PACKAGE OUTLINE

SOIC - 1.75 mm max height

SMALL OUTLINE INTEGRATED CIRCUIT



4214825/C 02/2019

NOTES:

1. Linear dimensions are in inches [millimeters]. Dimensions in parenthesis are for reference only. Controlling dimensions are in inches. Dimensioning and tolerancing per ASME Y14.5M.
2. This drawing is subject to change without notice.
3. This dimension does not include mold flash, protrusions, or gate burrs. Mold flash, protrusions, or gate burrs shall not exceed .006 [0.15] per side.
4. This dimension does not include interlead flash.
5. Reference JEDEC registration MS-012, variation AA.

EXAMPLE BOARD LAYOUT

D0008A

SOIC - 1.75 mm max height

SMALL OUTLINE INTEGRATED CIRCUIT



LAND PATTERN EXAMPLE
EXPOSED METAL SHOWN
SCALE:8X



SOLDER MASK DETAILS

4214825/C 02/2019

NOTES: (continued)

6. Publication IPC-7351 may have alternate designs.

7. Solder mask tolerances between and around signal pads can vary based on board fabrication site.

EXAMPLE STENCIL DESIGN

D0008A

SOIC - 1.75 mm max height

SMALL OUTLINE INTEGRATED CIRCUIT



SOLDER PASTE EXAMPLE
BASED ON .005 INCH [0.125 MM] THICK STENCIL
SCALE:8X

4214825/C 02/2019

NOTES: (continued)

8. Laser cutting apertures with trapezoidal walls and rounded corners may offer better paste release. IPC-7525 may have alternate design recommendations.
9. Board assembly site may have different recommendations for stencil design.

IMPORTANT NOTICE AND DISCLAIMER

TI PROVIDES TECHNICAL AND RELIABILITY DATA (INCLUDING DATASHEETS), DESIGN RESOURCES (INCLUDING REFERENCE DESIGNS), APPLICATION OR OTHER DESIGN ADVICE, WEB TOOLS, SAFETY INFORMATION, AND OTHER RESOURCES "AS IS" AND WITH ALL FAULTS, AND DISCLAIMS ALL WARRANTIES, EXPRESS AND IMPLIED, INCLUDING WITHOUT LIMITATION ANY IMPLIED WARRANTIES OF MERCHANTABILITY, FITNESS FOR A PARTICULAR PURPOSE OR NON-INFRINGEMENT OF THIRD PARTY INTELLECTUAL PROPERTY RIGHTS.

These resources are intended for skilled developers designing with TI products. You are solely responsible for (1) selecting the appropriate TI products for your application, (2) designing, validating and testing your application, and (3) ensuring your application meets applicable standards, and any other safety, security, or other requirements. These resources are subject to change without notice. TI grants you permission to use these resources only for development of an application that uses the TI products described in the resource. Other reproduction and display of these resources is prohibited. No license is granted to any other TI intellectual property right or to any third party intellectual property right. TI disclaims responsibility for, and you will fully indemnify TI and its representatives against, any claims, damages, costs, losses, and liabilities arising out of your use of these resources.

TI's products are provided subject to TI's Terms of Sale (www.ti.com/legal/termsofsale.html) or other applicable terms available either on ti.com or provided in conjunction with such TI products. TI's provision of these resources does not expand or otherwise alter TI's applicable warranties or warranty disclaimers for TI products.

Mailing Address: Texas Instruments, Post Office Box 655303, Dallas, Texas 75265
Copyright © 2019, Texas Instruments Incorporated

Looking for pricing, stock, or lifecycle information?

Click below to explore more details on WIN SOURCE:

 [View TPS3306-15DGKRG4 on WIN SOURCE](#)

 [Texas Instruments](#) Information

Optimize Your Supply Chain with WIN SOURCE Solutions

-  Global Sourcing Solution
-  Obsolete Management
-  Cost Control Management
-  Shortage Management
-  Alternative Solution
-  Excess Inventory Management