



**THE DATASHEET OF
TPS3305-25DGNR**





DUAL PROCESSOR SUPERVISORS

FEATURES

- Dual Supervisory Circuits for DSP- and Processor-Based Systems
- Power-On Reset Generator with Fixed Delay Time of 200ms; no External Capacitor Needed
- Watchdog Timer Retriggeres the $\overline{\text{RESET}}$ Output at $\text{SENSEn} \geq V_{IT+}$
- Temperature-Compensated Voltage Reference
- Maximum Supply Current of 40 μA
- Supply Voltage Range: 2.7V to 6V
- Defined $\overline{\text{RESET}}$ Output From $V_{DD} \geq 1.1\text{V}$
- MSOP-8 and SO-8 Packages
- Temperature Range: -40°C to $+85^{\circ}\text{C}$

APPLICATIONS

- Processor Supply Monitoring
- Industrial Equipment
- Automotive Systems
- Portable/Battery-Powered Equipment
- Wireless Communication Systems
- Notebook/Desktop Computers

DESCRIPTION

The TPS3305 family is a series of micropower supply voltage supervisors designed for circuit initialization. Its dual monitor topology is well-suited to use in DSP and processor-based systems, which often require two supply voltages, core and I/O.

$\overline{\text{RESET}}$ is asserted when the voltage at either SENSEn pin falls below its threshold voltage, V_{IT} . When both SENSEn pins are again above their respective threshold voltages, $\overline{\text{RESET}}$ is held low for the factory-programmed delay time (200ms typ). $\overline{\text{RESET}}$ is also asserted if the watchdog input (WDI) is not toggled for more than 1.6s typ.

The TPS3305-xx devices are available in either 8-pin MSOP or SO packages, and are specified for operation over a temperature range of -40°C to $+85^{\circ}\text{C}$.

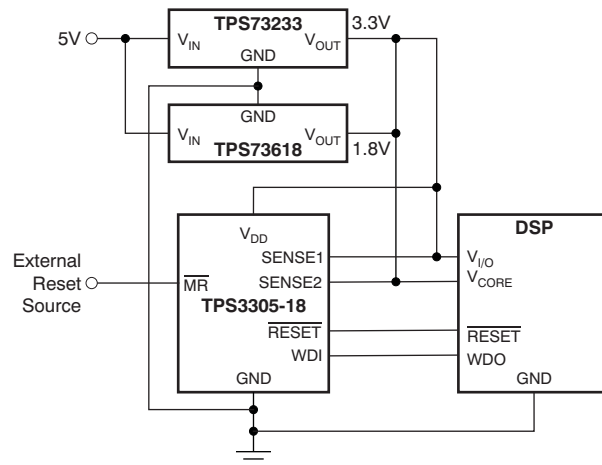
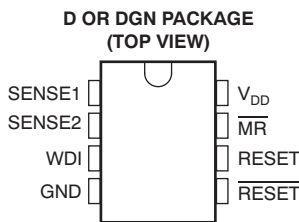

Please be aware that an important notice concerning availability, standard warranty, and use in critical applications of Texas Instruments semiconductor products and disclaimers thereto appears at the end of this data sheet.

All trademarks are the property of their respective owners.



This integrated circuit can be damaged by ESD. Texas Instruments recommends that all integrated circuits be handled with appropriate precautions. Failure to observe proper handling and installation procedures can cause damage.

ESD damage can range from subtle performance degradation to complete device failure. Precision integrated circuits may be more susceptible to damage because very small parametric changes could cause the device not to meet its published specifications.

ORDERING INFORMATION⁽¹⁾

DEVICE	NOMINAL SUPERVISED VOLTAGE		THRESHOLD VOLTAGE (TYP)	
	SENSE1	SENSE2	SENSE1	SENSE2
TPS3305-18	3.3 V	1.8 V	2.93 V	1.68 V
TPS3305-25	3.3 V	2.5 V	2.93 V	2.25 V
TPS3305-33	5.0 V	3.3 V	4.55 V	2.93 V

(1) For the most current specifications and package information, see the Package Option Addendum at the end of this document, or see the TI website at www.ti.com.

ABSOLUTE MAXIMUM RATINGS⁽¹⁾⁽²⁾

Over operating junction temperature range (unless otherwise noted).

	UNIT
Supply voltage range, V_{DD}	-0.3V to +7V
V_{MR} , V_{WDI}	-0.3V to $V_{DD} + 0.3V$
Input voltage at SENSE1 and SENSE2, V_I	$(V_{DD} + 0.3)V_{IT} / 1.25V$
V_{RESET} , $V_{\overline{RESET}}$	-0.3V to +7V
Maximum low output current, I_{OL}	5mA
Maximum high output current, I_{OH}	-5mA
Input clamp current, I_{IK} ($V_I < 0$ or $V_I > V_{DD}$)	$\pm 20mA$
Output clamp current, I_{OK} ($V_O < 0$ or $V_O > V_{DD}$)	$\pm 20mA$
Continuous total power dissipation	See Dissipation Ratings Table
Operating junction temperature range, T_J	-40°C to +85°C
Storage temperature range, T_{stg}	-65°C to +150°C
Soldering temperature	+260°C

(1) Stresses beyond those listed under *absolute maximum ratings* may cause permanent damage to the device. These are stress ratings only, and functional operation of the device at these or any other conditions beyond those indicated under *recommended operating conditions* is not implied. Exposure to absolute-maximum-rated conditions for extended periods may affect device reliability.

(2) All voltage values are with respect to GND.

DISSIPATION RATINGS TABLE

PACKAGE	$T_A \leq +25^\circ C$ POWER RATING	DERATING FACTOR ABOVE $T_A = +25^\circ C$	$T_A = +70^\circ C$ POWER RATING	$T_A = +85^\circ C$ POWER RATING
DGN	2.14W	17.1mW/°C	1.37W	1.11W
D	725mW	5.8mW/°C	464mW	377mW

ELECTRICAL CHARACTERISTICS

Over operating junction temperature range (unless otherwise noted).

PARAMETER		TEST CONDITIONS	TPS3305-xx			UNIT	
			MIN	TYP	MAX		
V _{DD}	Input supply range		2.7		6.0	V	
T _J	Operating junction temperature range		-40		+85	°C	
V _{OH}	High-level output voltage	V _{DD} = 2.7V to 6V, I _{OH} = -20μA	V _{DD} - 0.2V			V	
		V _{DD} = 3.3V, I _{OH} = -2mA	V _{DD} - 0.4V			V	
		V _{DD} = 6V, I _{OH} = -3mA	V _{DD} - 0.4V			V	
V _{OL}	Low-level output voltage	V _{DD} = 2.7V to 6V, I _{OL} = 20μA	0.2			V	
		V _{DD} = 3.3V, I _{OL} = 2mA	0.4			V	
		V _{DD} = 6V, I _{OL} = 3mA	0.4			V	
Power-up reset voltage ⁽¹⁾		V _{DD} ≥ 1.1V, I _{OL} = 20μA	0.4			V	
V _{IT-}	Negative-going input threshold voltage ⁽²⁾	V _{DD} = 2.7V to 6V, T _A = 0°C to +85°C	VSENSE1, VSENSE2	1.64	1.68	1.72	V
				2.20	2.25	2.30	V
				2.86	2.93	3.0	V
				4.46	4.55	4.64	V
		V _{DD} = 2.7V to 6V, T _A = -40°C to +85°C	VSENSE1, VSENSE2	1.64	1.68	1.73	V
			2.20	2.25	2.32	V	
			2.86	2.93	3.02	V	
			4.46	4.55	4.67	V	
V _{hys}	Hysteresis at VSENSEn input	V _{IT-} = 1.68V	15			mV	
		V _{IT-} = 2.25V	20			mV	
		V _{IT-} = 2.93V	30			mV	
		V _{IT-} = 4.55V	40			mV	
I _{H(AV)}	Average high-level input current	WDI	WDI = V _{DD} = 6V Time average (dc = 88%)		100	150	μA
I _{L(AV)}	Average low-level input current	WDI	WDI = 0V, V _{DD} = 6V Time average (dc = 12%)		-15	-20	μA
V _{IH}	High-level input voltage at \overline{MR} and WDI		0.7 x V _{DD}			V	
V _{IL}	Low-level input voltage at \overline{MR} and WDI		0.3 x V _{DD}			V	
Δt / ΔV	Input transition rise and fall rate at \overline{MR}		50			ns/V	
I _H	High-level input current	WDI	WDI = V _{DD} = 6V		120	170	μA
		\overline{MR}	$\overline{MR} = 0.7 \times V_{DD}$, V _{DD} = 6V		-130	-180	μA
		SENSE1	VSENSE1 = V _{DD} = 6V		5	8	μA
		SENSE2	VSENSE2 = V _{DD} = 6V		6	9	μA
I _L	Low-level input current	WDI	WDI = 0V, V _{DD} = 6V		-120	-170	μA
		\overline{MR}	$\overline{MR} = 0V$, V _{DD} = 6V		-430	-600	μA
		SENSEn	VSENSE1,2 = 0V		-1	1	μA
I _{DD}	Supply current		40			μA	
C _I	Input capacitance	V _I = 0V to V _{DD}	10			pF	

(1) The lowest supply voltage at which \overline{RESET} becomes active. t_r, V_{DD} ≥ 15 μs/V.

(2) To ensure best stability of the threshold voltage, a bypass capacitor (0.1 μF ceramic) should be placed close to the supply terminals.

TIMING DIAGRAM

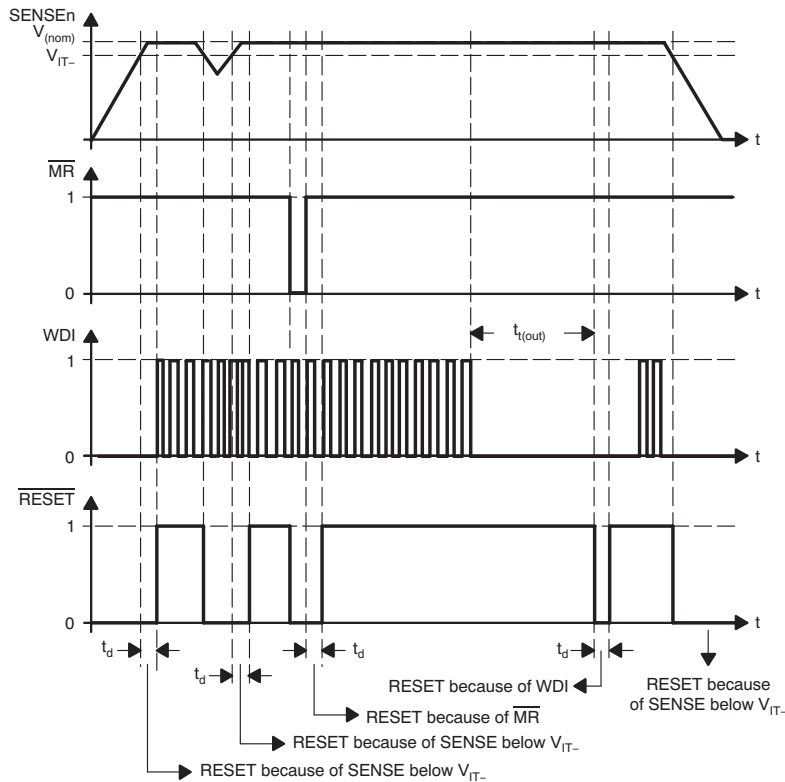

TIMING REQUIREMENTS

At $V_{DD} = 2.7V$ to $6V$, $R_L = 1M\Omega$, $C_L = 50pF$, and $T_J = +25^\circ C$.

PARAMETER		TEST CONDITIONS	MIN	TYP	MAX	UNIT
t_w	Pulse width	$V_{SENSEnL} = V_{IT-} - 0.2V$, $V_{SENSEnH} = V_{IT+} + 0.2V$	6			μs
		$V_{IH} = 0.7 \times V_{DD}$, $V_{IL} = 0.3 \times V_{DD}$	100			ns
			100			ns

SWITCHING CHARACTERISTICS

At $V_{DD} = 2.7V$ to $6V$, $R_L = 1M\Omega$, $C_L = 50pF$, and $T_J = +25^\circ C$.

PARAMETER		TEST CONDITIONS	MIN	TYP	MAX	UNIT
$t_{t(out)}$	Watchdog time-out	$V_{I(SENSEn)} \geq V_{IT+} + 0.2V$, $\overline{MR} \geq 0.7 \times V_{DD}$ See Timing Diagram	1.1	1.6	2.3	s
t_d	Delay time	$V_{I(SENSEn)} \geq V_{IT+} + 0.2V$, $\overline{MR} \geq 0.7 \times V_{DD}$ See Timing Diagram	140	200	280	ms
t_{PHL}	Propagation (delay) time, high-to-low level output	\overline{MR} to \overline{RESET} , \overline{MR} to RESET $V_{I(SENSEn)} \geq V_{IT+} + 0.2V$, $V_{IH} = 0.7 \times V_{DD}$, $V_{IL} = 0.3 \times V_{DD}$		200	500	ns
t_{PLH}	Propagation (delay) time, low-to-high level output	\overline{MR} to \overline{RESET} , \overline{MR} to RESET $V_{I(SENSEn)} \geq V_{IT+} + 0.2V$, $V_{IH} = 0.7 \times V_{DD}$, $V_{IL} = 0.3 \times V_{DD}$		200	500	ns
t_{PHL}	Propagation (delay) time, high-to-low level output	$SENSEn$ to \overline{RESET} , $SENSEn$ to RESET $V_{IH} = V_{IT+} + 0.2V$, $V_{IL} = V_{IT-} - 0.2V$, $\overline{MR} \geq 0.7 \times V_{DD}$		1	5	μs
t_{PLH}	Propagation (delay) time, low-to-high level output	$SENSEn$ to \overline{RESET} , $SENSEn$ to RESET $V_{IH} = V_{IT+} + 0.2V$, $V_{IL} = V_{IT-} - 0.2V$, $\overline{MR} \geq 0.7 \times V_{DD}$		1	5	μs

DEVICE INFORMATION

FUNCTION/TRUTH TABLE⁽¹⁾

MR	SENSE1 > V _{IT1}	SENSE2 > V _{IT2}	RESET	RESET
L	X	X	L	H
H	0	0	L	H
H	0	1	L	H
H	1	0	L	H
H	1	1	H	L

(1) X = Don't care

FUNCTIONAL BLOCK DIAGRAM

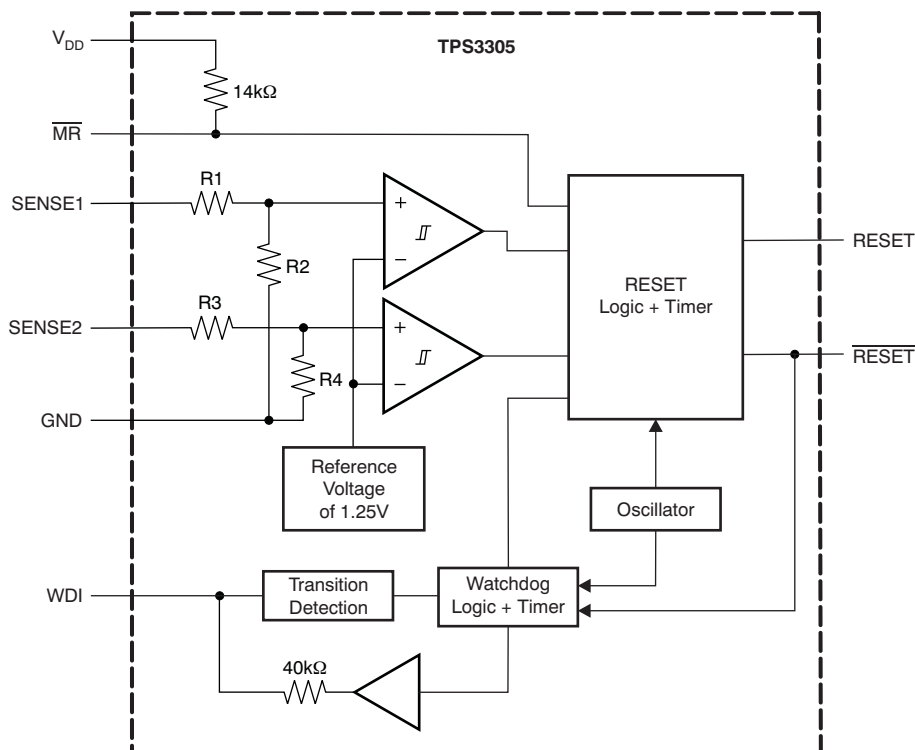

TERMINAL FUNCTIONS

TERMINAL		DESCRIPTION
NAME	NO.	
GND	4	Ground
MR	7	Manual reset
RESET	5	Active-low reset output
RESET	6	Active-high reset output
SENSE1	1	Sense voltage input 1
SENSE2	2	Sense voltage input 2
WDI	3	Watchdog timer input
V _{DD}	8	Supply voltage

TYPICAL CHARACTERISTICS

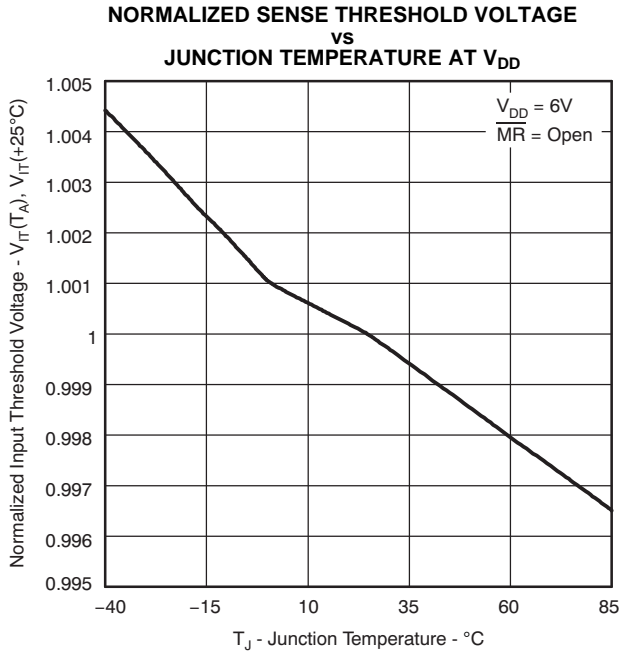

Figure 1.

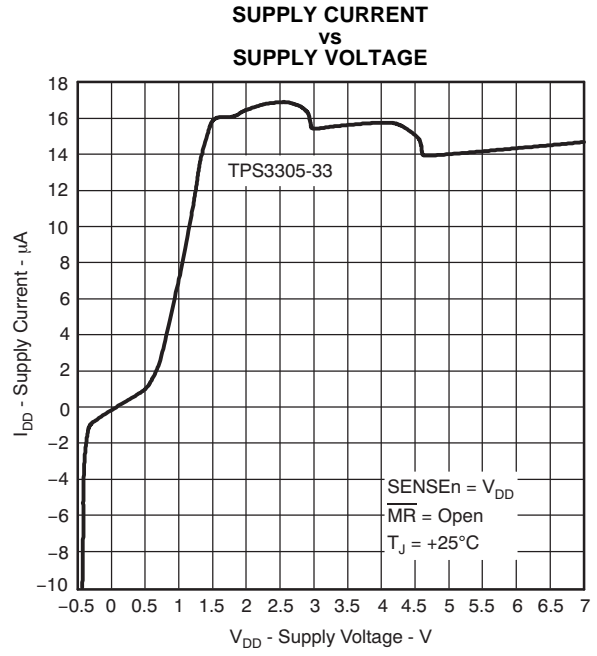

Figure 2.

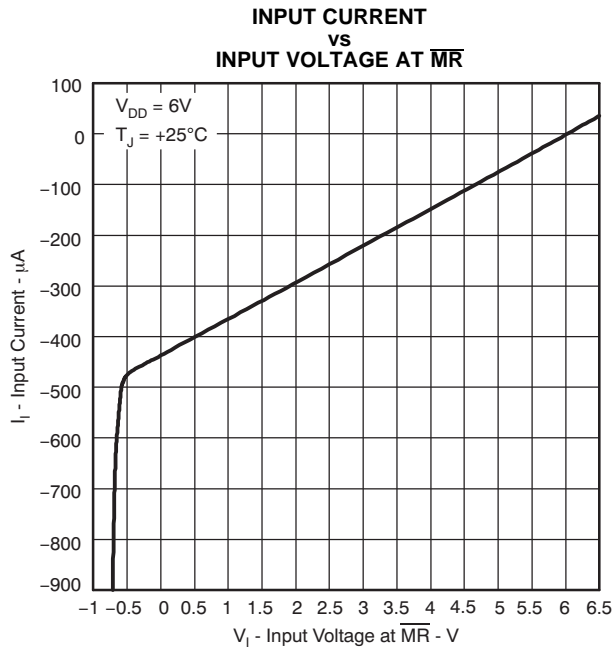

Figure 3.

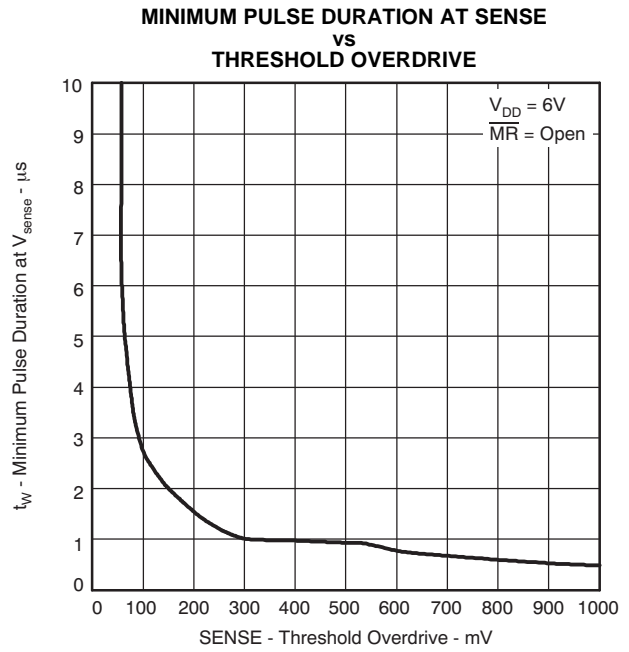
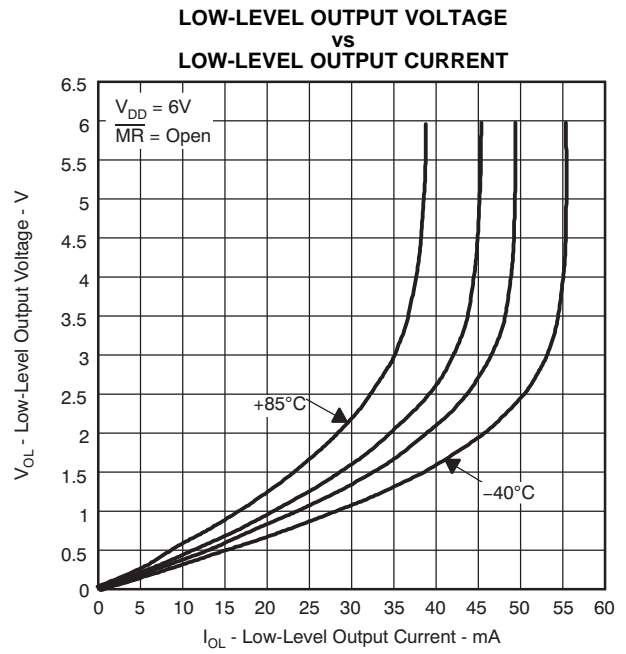
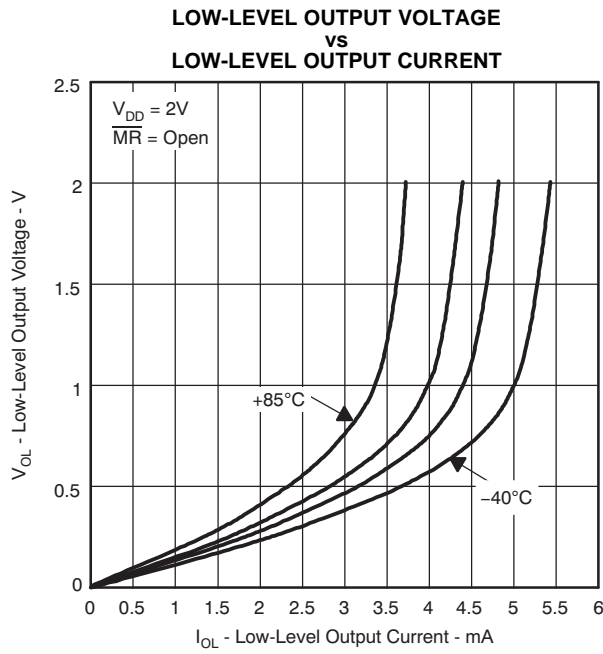
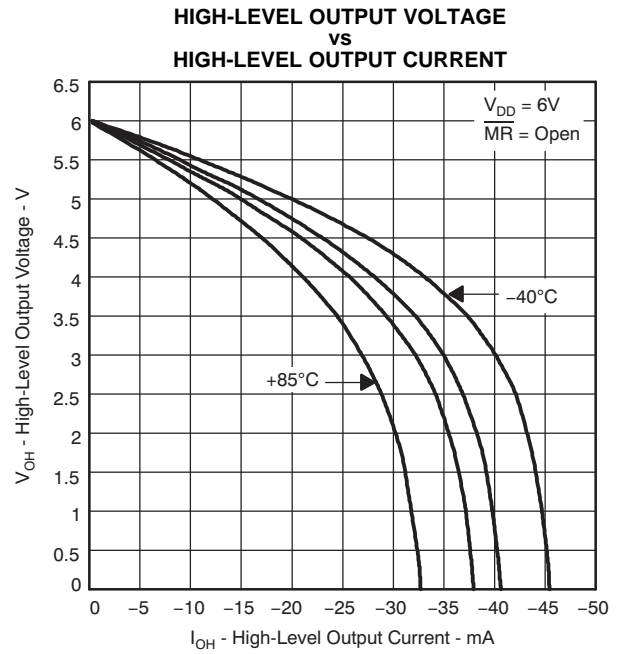
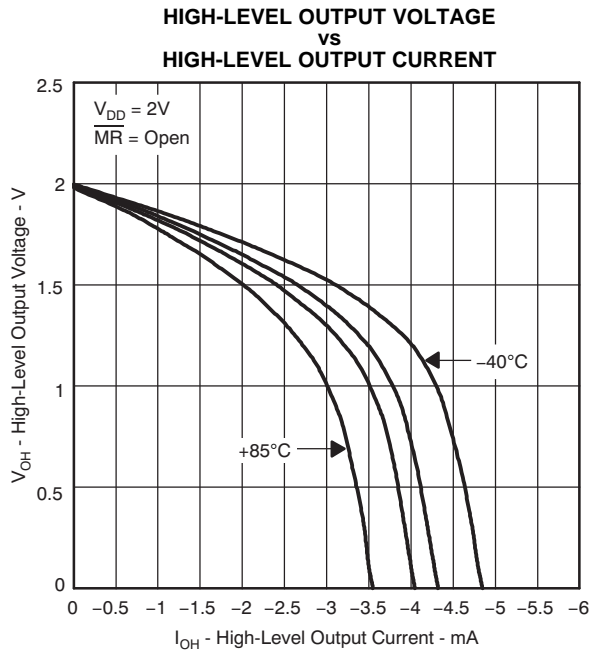

Figure 4.

TYPICAL CHARACTERISTICS (continued)



PACKAGING INFORMATION

Orderable Device	Status (1)	Package Type	Package Drawing	Pins	Package Qty	Eco Plan (2)	Lead/Ball Finish (6)	MSL Peak Temp (3)	Op Temp (°C)	Device Marking (4/5)	Samples
TPS3305-18D	ACTIVE	SOIC	D	8	75	Green (RoHS & no Sb/Br)	CU NIPDAU	Level-1-260C-UNLIM	-40 to 85	30518	Samples
TPS3305-18DG4	ACTIVE	SOIC	D	8	75	Green (RoHS & no Sb/Br)	CU NIPDAU	Level-1-260C-UNLIM	-40 to 85	30518	Samples
TPS3305-18DGN	ACTIVE	MSOP-PowerPAD	DGN	8	80	Green (RoHS & no Sb/Br)	CU NIPDAU	Level-1-260C-UNLIM	-40 to 85	AAM	Samples
TPS3305-18DGNG4	ACTIVE	MSOP-PowerPAD	DGN	8	80	Green (RoHS & no Sb/Br)	CU NIPDAU	Level-1-260C-UNLIM	-40 to 85	AAM	Samples
TPS3305-18DGNR	ACTIVE	MSOP-PowerPAD	DGN	8	2500	Green (RoHS & no Sb/Br)	CU NIPDAU	Level-1-260C-UNLIM	-40 to 85	AAM	Samples
TPS3305-18DGNRG4	ACTIVE	MSOP-PowerPAD	DGN	8	2500	Green (RoHS & no Sb/Br)	CU NIPDAU	Level-1-260C-UNLIM	-40 to 85	AAM	Samples
TPS3305-18DR	ACTIVE	SOIC	D	8	2500	Green (RoHS & no Sb/Br)	CU NIPDAU	Level-1-260C-UNLIM	-40 to 85	30518	Samples
TPS3305-18DRG4	ACTIVE	SOIC	D	8	2500	Green (RoHS & no Sb/Br)	CU NIPDAU	Level-1-260C-UNLIM	-40 to 85	30518	Samples
TPS3305-25D	ACTIVE	SOIC	D	8	75	Green (RoHS & no Sb/Br)	CU NIPDAU	Level-1-260C-UNLIM	-40 to 85	30525	Samples
TPS3305-25DGN	ACTIVE	MSOP-PowerPAD	DGN	8	80	Green (RoHS & no Sb/Br)	CU NIPDAU	Level-1-260C-UNLIM	-40 to 85	AAN	Samples
TPS3305-25DGNR	ACTIVE	MSOP-PowerPAD	DGN	8	2500	Green (RoHS & no Sb/Br)	CU NIPDAU	Level-1-260C-UNLIM	-40 to 85	AAN	Samples
TPS3305-25DR	ACTIVE	SOIC	D	8	2500	Green (RoHS & no Sb/Br)	CU NIPDAU	Level-1-260C-UNLIM	-40 to 85	30525	Samples
TPS3305-33D	ACTIVE	SOIC	D	8	75	Green (RoHS & no Sb/Br)	CU NIPDAU	Level-1-260C-UNLIM	-40 to 85	30533	Samples
TPS3305-33DG4	ACTIVE	SOIC	D	8	75	Green (RoHS & no Sb/Br)	CU NIPDAU	Level-1-260C-UNLIM	-40 to 85	30533	Samples
TPS3305-33DGN	ACTIVE	MSOP-PowerPAD	DGN	8	80	Green (RoHS & no Sb/Br)	CU NIPDAU	Level-1-260C-UNLIM	-40 to 85	AAO	Samples
TPS3305-33DGNG4	ACTIVE	MSOP-PowerPAD	DGN	8	80	Green (RoHS & no Sb/Br)	CU NIPDAU	Level-1-260C-UNLIM	-40 to 85	AAO	Samples
TPS3305-33DGNR	ACTIVE	MSOP-PowerPAD	DGN	8	2500	Green (RoHS & no Sb/Br)	CU NIPDAU	Level-1-260C-UNLIM	-40 to 85	AAO	Samples

Orderable Device	Status (1)	Package Type	Package Drawing	Pins	Package Qty	Eco Plan (2)	Lead/Ball Finish (6)	MSL Peak Temp (3)	Op Temp (°C)	Device Marking (4/5)	Samples
TPS3305-33DGNRG4	ACTIVE	MSOP- PowerPAD	DGN	8	2500	Green (RoHS & no Sb/Br)	CU NIPDAU	Level-1-260C-UNLIM	-40 to 85	AAO	Samples
TPS3305-33DR	ACTIVE	SOIC	D	8	2500	Green (RoHS & no Sb/Br)	CU NIPDAU	Level-1-260C-UNLIM	-40 to 85	30533	Samples

(1) The marketing status values are defined as follows:

ACTIVE: Product device recommended for new designs.

LIFEBUY: TI has announced that the device will be discontinued, and a lifetime-buy period is in effect.

NRND: Not recommended for new designs. Device is in production to support existing customers, but TI does not recommend using this part in a new design.

PREVIEW: Device has been announced but is not in production. Samples may or may not be available.

OBSOLETE: TI has discontinued the production of the device.

(2) **RoHS:** TI defines "RoHS" to mean semiconductor products that are compliant with the current EU RoHS requirements for all 10 RoHS substances, including the requirement that RoHS substance do not exceed 0.1% by weight in homogeneous materials. Where designed to be soldered at high temperatures, "RoHS" products are suitable for use in specified lead-free processes. TI may reference these types of products as "Pb-Free".

RoHS Exempt: TI defines "RoHS Exempt" to mean products that contain lead but are compliant with EU RoHS pursuant to a specific EU RoHS exemption.

Green: TI defines "Green" to mean the content of Chlorine (Cl) and Bromine (Br) based flame retardants meet JS709B low halogen requirements of <=1000ppm threshold. Antimony trioxide based flame retardants must also meet the <=1000ppm threshold requirement.

(3) MSL, Peak Temp. - The Moisture Sensitivity Level rating according to the JEDEC industry standard classifications, and peak solder temperature.

(4) There may be additional marking, which relates to the logo, the lot trace code information, or the environmental category on the device.

(5) Multiple Device Markings will be inside parentheses. Only one Device Marking contained in parentheses and separated by a "~" will appear on a device. If a line is indented then it is a continuation of the previous line and the two combined represent the entire Device Marking for that device.

(6) Lead/Ball Finish - Orderable Devices may have multiple material finish options. Finish options are separated by a vertical ruled line. Lead/Ball Finish values may wrap to two lines if the finish value exceeds the maximum column width.

Important Information and Disclaimer:The information provided on this page represents TI's knowledge and belief as of the date that it is provided. TI bases its knowledge and belief on information provided by third parties, and makes no representation or warranty as to the accuracy of such information. Efforts are underway to better integrate information from third parties. TI has taken and continues to take reasonable steps to provide representative and accurate information but may not have conducted destructive testing or chemical analysis on incoming materials and chemicals. TI and TI suppliers consider certain information to be proprietary, and thus CAS numbers and other limited information may not be available for release.

In no event shall TI's liability arising out of such information exceed the total purchase price of the TI part(s) at issue in this document sold by TI to Customer on an annual basis.

TAPE AND REEL INFORMATION

QUADRANT ASSIGNMENTS FOR PIN 1 ORIENTATION IN TAPE

*All dimensions are nominal

Device	Package Type	Package Drawing	Pins	SPQ	Reel Diameter (mm)	Reel Width W1 (mm)	A0 (mm)	B0 (mm)	K0 (mm)	P1 (mm)	W (mm)	Pin1 Quadrant
TPS3305-18DGNR	MSOP-Power PAD	DGN	8	2500	330.0	12.4	5.3	3.4	1.4	8.0	12.0	Q1
TPS3305-18DR	SOIC	D	8	2500	330.0	12.4	6.4	5.2	2.1	8.0	12.0	Q1
TPS3305-25DGNR	MSOP-Power PAD	DGN	8	2500	330.0	12.4	5.3	3.4	1.4	8.0	12.0	Q1
TPS3305-25DR	SOIC	D	8	2500	330.0	12.4	6.4	5.2	2.1	8.0	12.0	Q1
TPS3305-33DGNR	MSOP-Power PAD	DGN	8	2500	330.0	12.4	5.3	3.4	1.4	8.0	12.0	Q1
TPS3305-33DR	SOIC	D	8	2500	330.0	12.4	6.4	5.2	2.1	8.0	12.0	Q1

TAPE AND REEL BOX DIMENSIONS

*All dimensions are nominal

Device	Package Type	Package Drawing	Pins	SPQ	Length (mm)	Width (mm)	Height (mm)
TPS3305-18DGNR	MSOP-PowerPAD	DGN	8	2500	358.0	335.0	35.0
TPS3305-18DR	SOIC	D	8	2500	350.0	350.0	43.0
TPS3305-25DGNR	MSOP-PowerPAD	DGN	8	2500	358.0	335.0	35.0
TPS3305-25DR	SOIC	D	8	2500	350.0	350.0	43.0
TPS3305-33DGNR	MSOP-PowerPAD	DGN	8	2500	358.0	335.0	35.0
TPS3305-33DR	SOIC	D	8	2500	350.0	350.0	43.0



D0008A

PACKAGE OUTLINE

SOIC - 1.75 mm max height

SMALL OUTLINE INTEGRATED CIRCUIT



4214825/C 02/2019

NOTES:

1. Linear dimensions are in inches [millimeters]. Dimensions in parenthesis are for reference only. Controlling dimensions are in inches. Dimensioning and tolerancing per ASME Y14.5M.
2. This drawing is subject to change without notice.
3. This dimension does not include mold flash, protrusions, or gate burrs. Mold flash, protrusions, or gate burrs shall not exceed $.006$ [0.15] per side.
4. This dimension does not include interlead flash.
5. Reference JEDEC registration MS-012, variation AA.

EXAMPLE BOARD LAYOUT

D0008A

SOIC - 1.75 mm max height

SMALL OUTLINE INTEGRATED CIRCUIT



LAND PATTERN EXAMPLE
EXPOSED METAL SHOWN
SCALE:8X



SOLDER MASK DETAILS

4214825/C 02/2019

NOTES: (continued)

- 6. Publication IPC-7351 may have alternate designs.
- 7. Solder mask tolerances between and around signal pads can vary based on board fabrication site.

EXAMPLE STENCIL DESIGN

D0008A

SOIC - 1.75 mm max height

SMALL OUTLINE INTEGRATED CIRCUIT



SOLDER PASTE EXAMPLE
BASED ON .005 INCH [0.125 MM] THICK STENCIL
SCALE:8X

4214825/C 02/2019

NOTES: (continued)

8. Laser cutting apertures with trapezoidal walls and rounded corners may offer better paste release. IPC-7525 may have alternate design recommendations.
9. Board assembly site may have different recommendations for stencil design.

DGN (S-PDSO-G8)

PowerPAD™ PLASTIC SMALL OUTLINE

THERMAL INFORMATION

This PowerPAD™ package incorporates an exposed thermal pad that is designed to be attached to a printed circuit board (PCB). The thermal pad must be soldered directly to the PCB. After soldering, the PCB can be used as a heatsink. In addition, through the use of thermal vias, the thermal pad can be attached directly to the appropriate copper plane shown in the electrical schematic for the device, or alternatively, can be attached to a special heatsink structure designed into the PCB. This design optimizes the heat transfer from the integrated circuit (IC).

For additional information on the PowerPAD package and how to take advantage of its heat dissipating abilities, refer to Technical Brief, PowerPAD Thermally Enhanced Package, Texas Instruments Literature No. SLMA002 and Application Brief, PowerPAD Made Easy, Texas Instruments Literature No. SLMA004. Both documents are available at www.ti.com.

The exposed thermal pad dimensions for this package are shown in the following illustration.

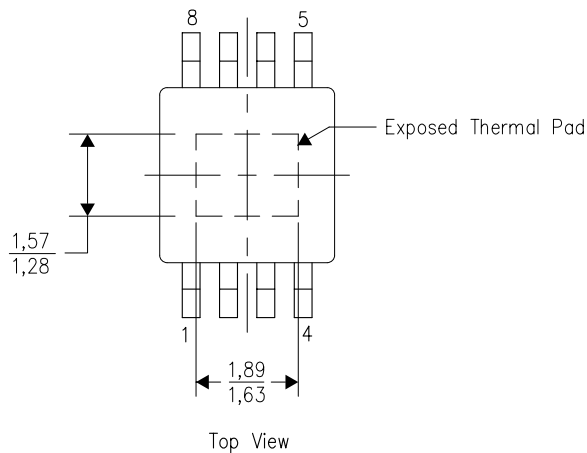

4206323-2/1 12/11

NOTE: All linear dimensions are in millimeters

PowerPAD is a trademark of Texas Instruments

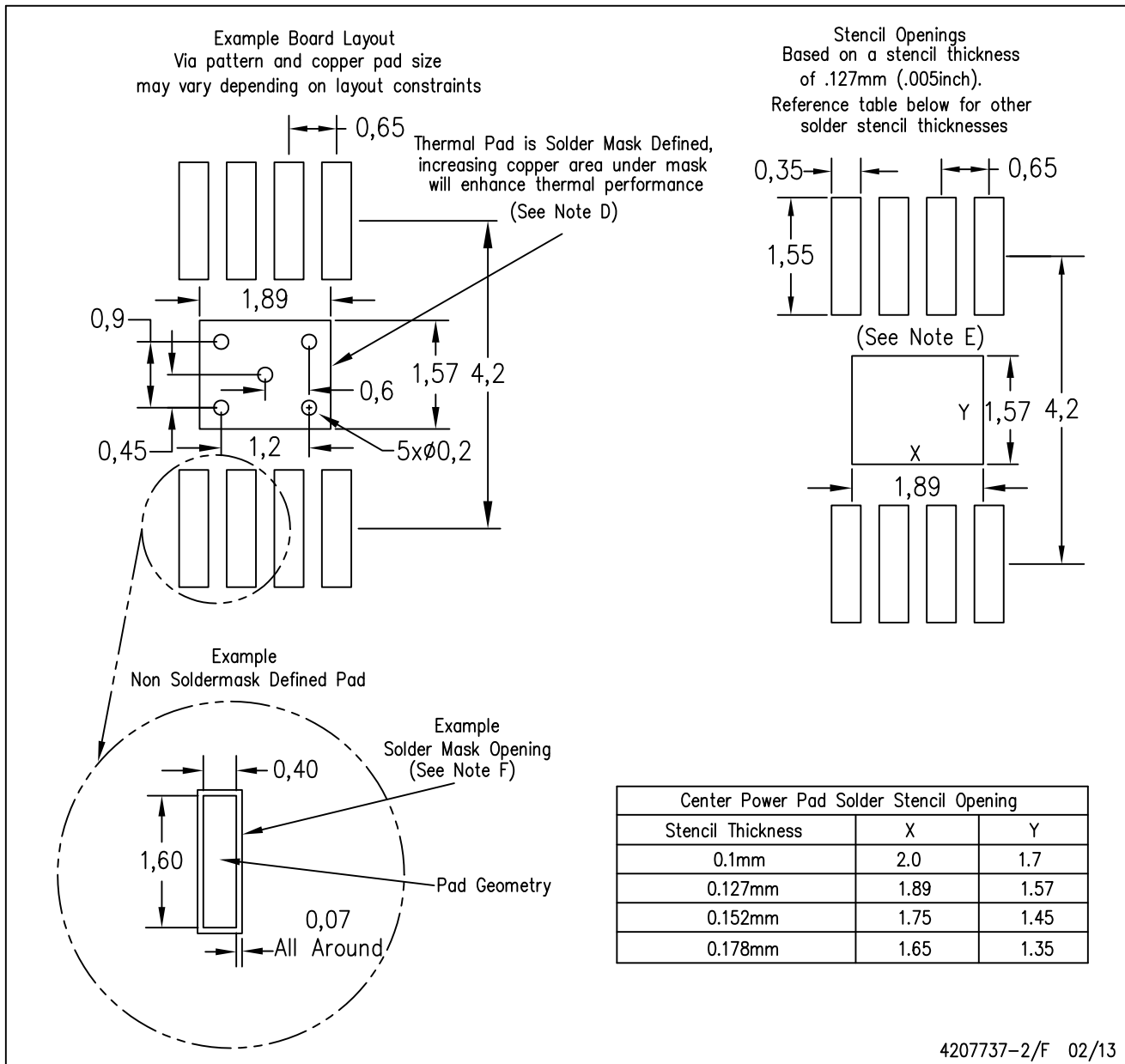

- NOTES:
- A. All linear dimensions are in millimeters.
 - B. This drawing is subject to change without notice.
 - C. Customers should place a note on the circuit board fabrication drawing not to alter the center solder mask defined pad.
 - D. This package is designed to be soldered to a thermal pad on the board. Refer to Technical Brief, PowerPad Thermally Enhanced Package, Texas Instruments Literature No. SLMA002, SLMA004, and also the Product Data Sheets for specific thermal information, via requirements, and recommended board layout. These documents are available at www.ti.com <<http://www.ti.com>>.
 - E. Laser cutting apertures with trapezoidal walls and also rounding corners will offer better paste release. Customers should contact their board assembly site for stencil design recommendations. Example stencil design based on a 50% volumetric metal load solder paste. Refer to IPC-7525 for other stencil recommendations.
 - F. Customers should contact their board fabrication site for solder mask tolerances between and around signal pads.

PowerPAD is a trademark of Texas Instruments

IMPORTANT NOTICE AND DISCLAIMER

TI PROVIDES TECHNICAL AND RELIABILITY DATA (INCLUDING DATASHEETS), DESIGN RESOURCES (INCLUDING REFERENCE DESIGNS), APPLICATION OR OTHER DESIGN ADVICE, WEB TOOLS, SAFETY INFORMATION, AND OTHER RESOURCES "AS IS" AND WITH ALL FAULTS, AND DISCLAIMS ALL WARRANTIES, EXPRESS AND IMPLIED, INCLUDING WITHOUT LIMITATION ANY IMPLIED WARRANTIES OF MERCHANTABILITY, FITNESS FOR A PARTICULAR PURPOSE OR NON-INFRINGEMENT OF THIRD PARTY INTELLECTUAL PROPERTY RIGHTS.

These resources are intended for skilled developers designing with TI products. You are solely responsible for (1) selecting the appropriate TI products for your application, (2) designing, validating and testing your application, and (3) ensuring your application meets applicable standards, and any other safety, security, or other requirements. These resources are subject to change without notice. TI grants you permission to use these resources only for development of an application that uses the TI products described in the resource. Other reproduction and display of these resources is prohibited. No license is granted to any other TI intellectual property right or to any third party intellectual property right. TI disclaims responsibility for, and you will fully indemnify TI and its representatives against, any claims, damages, costs, losses, and liabilities arising out of your use of these resources.

TI's products are provided subject to TI's Terms of Sale (www.ti.com/legal/termsofsale.html) or other applicable terms available either on ti.com or provided in conjunction with such TI products. TI's provision of these resources does not expand or otherwise alter TI's applicable warranties or warranty disclaimers for TI products.

Mailing Address: Texas Instruments, Post Office Box 655303, Dallas, Texas 75265
Copyright © 2019, Texas Instruments Incorporated

Looking for pricing, stock, or lifecycle information?

Click below to explore more details on WIN SOURCE:

 [View TPS3305-25DGNR on WIN SOURCE](#)

 [Texas Instruments](#) Information

Optimize Your Supply Chain with WIN SOURCE Solutions

-  Global Sourcing Solution
-  Obsolete Management
-  Cost Control Management
-  Shortage Management
-  Alternative Solution
-  Excess Inventory Management