

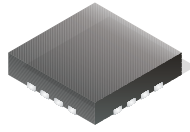

# THE DATASHEET OF TPS25910RSAR





## 6.5-A, 20-V Integrated Hotswap with Programmable Inrush Slew Rate

Check for Samples: [TPS25910](#)

### FEATURES

- Up to 20-V Bus Operation
- Integrated 30-mΩ Pass MOSFET
- Programmable Current Limit from: 0.83 A to 6.5 A
- Programmable Inrush Current Slew Rate
- Thermal Shutdown and fault alert
- 4-mm x 4-mm QFN16
- –40°C to 125°C Junction Temperature Range
- UL2367 Recognized - File Number E169910
- CB Certified

### APPLICATIONS

- Solid State Drive (SSD)
- Hard Disk Drive (HDD)
- RAID Arrays
- Telecommunications
- Plug-In Circuit Boards
- Notebooks and Netbooks
- PCIE
- Fan Control

### DESCRIPTION

The TPS25910 device provides highly integrated hot-swap power management and superior protection in applications up to 20 V. The maximum UV turn-on threshold of 2.9 V makes the TPS25910 device well suited to standard bus voltages as low as 3.3 V. This device is intended for systems where a voltage bus must be protected from undesired permanent and transient overload.

At start-up or when hot plugging into the system bus, the TPS25910 device limits the inrush current by controlling the ramp rate of the output voltage,  $V_{OUT}$ . The slew rate of  $V_{OUT}$  can be adjusted with a capacitor between the GATE pin and the GND pin.

Built in SOA protection ensures that the internal MOSFET operates inside a safe operating area (SOA) under the harshest operating conditions. In addition, the current-limit threshold, which is independent of the power limit, can be adjusted with a resistor between the ILIM pin and the GND pin.

The TPS25910 device provides a fault indicator output when in thermal fault.

The TPS25910 device is available in a 16-pin QFN package.

### 12-V, 4.75-A APPLICATION

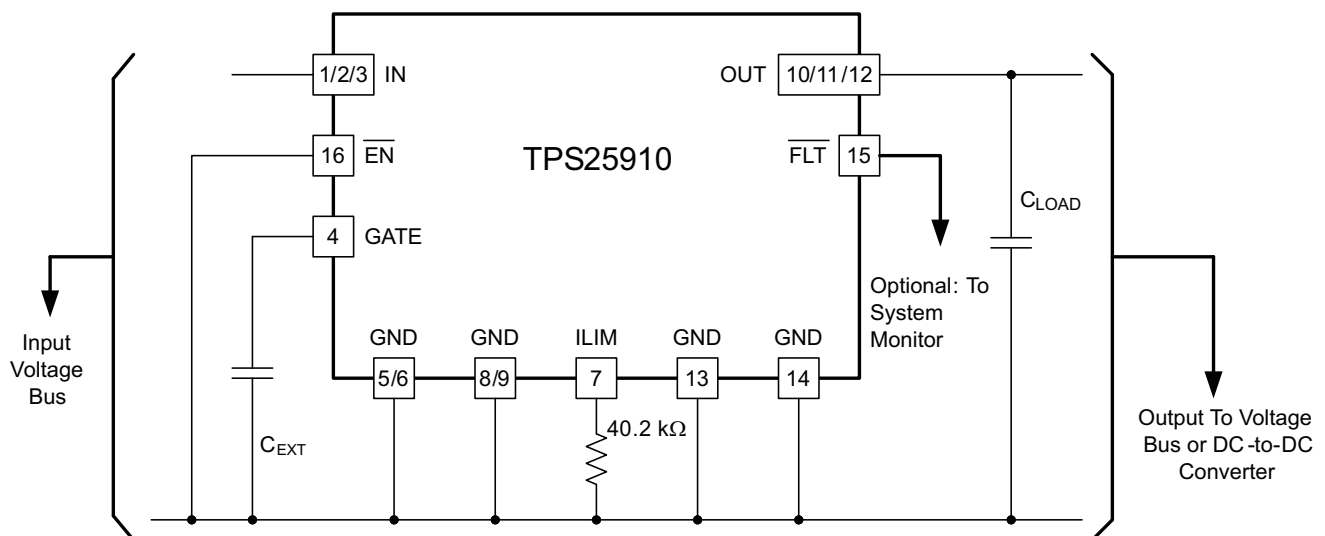

Please be aware that an important notice concerning availability, standard warranty, and use in critical applications of Texas Instruments semiconductor products and disclaimers thereto appears at the end of this data sheet.



These devices have limited built-in ESD protection. The leads should be shorted together or the device placed in conductive foam during storage or handling to prevent electrostatic damage to the MOS gates.

## ABSOLUTE MAXIMUM RATINGS

over device junction temperature range (unless otherwise noted)<sup>(1)(2)</sup>

		MIN	MAX	UNIT
Input voltage range IN, OUT		-0.3	22	V
Voltage range, GATE		-0.3	30	
Voltage range $\overline{\text{FLT}}$		-0.3	20	V
Voltage ILIM			1.75	
Output sink current $\overline{\text{FLT}}$			10	mA
Input voltage range, $\overline{\text{EN}}$		-0.3	6	
Voltage range ILIM <sup>(3)</sup>		-0.3	3	V
ESD rating	Human body model (HBM)		2.5	kV
	Charged device model (CDM)		500	V
Operating junction temperature range, T <sub>J</sub>		Internally Limited		°C
Storage temperature range, T <sub>stg</sub>		-65	150	

- (1) Stresses beyond those listed under *absolute maximum ratings* may cause permanent damage to the device. These are stress ratings only, and functional operation of the device at these or any other conditions beyond those indicated under *recommended operating conditions* is not implied. Exposure to absolute-maximum-rated conditions for extended periods may affect device reliability.
- (2) All voltage values are with respect to GND.
- (3) Do not apply voltage to pin.

## RECOMMENDED OPERATING CONDITIONS

over device junction temperature range (unless otherwise noted)

PARAMETER	MIN	NOM	MAX	UNIT
Input voltage range IN, OUT	3		20	V
Voltage range $\overline{EN}$	0		5	
Voltage range $\overline{FLT}$	0		20	
Continuous output current I <sub>OUT</sub>	0		5	A
Output sink current $\overline{FLT}$	0		1	mA
External Capacitor, GATE	1		47	nF
dV/dt, V <sub>IN</sub> <sup>(1)</sup>			12	V/μS
R <sub>LIM</sub> <sup>(2)</sup>	0		237k	Ω
Junction temperature	-40		125	°C

(1) dV/dt, V<sub>IN</sub> should be limited to 12 V/μS to confine the shoot-through current to the load.

(2) When R<sub>LIM</sub> value is beyond this range, I<sub>LIM</sub> will not be as accurate as within this range.

## THERMAL INFORMATION

THERMAL METRIC <sup>(1)</sup>		TPS25910	UNITS
		RSA (QFN)	
		16 PINS	
θ <sub>JA</sub>	Junction-to-ambient thermal resistance <sup>(2)</sup>	34.8	°C/W
θ <sub>JCtop</sub>	Junction-to-case (top) thermal resistance <sup>(3)</sup>	35.3	
θ <sub>JB</sub>	Junction-to-board thermal resistance <sup>(4)</sup>	11.9	
ψ <sub>JT</sub>	Junction-to-top characterization parameter <sup>(5)</sup>	0.4	
ψ <sub>JB</sub>	Junction-to-board characterization parameter <sup>(6)</sup>	12.0	
θ <sub>JCbot</sub>	Junction-to-case (bottom) thermal resistance <sup>(7)</sup>	3.3	

(1) For more information about traditional and new thermal metrics, see the *IC Package Thermal Metrics* application report, [SPRA953](#).

(2) The junction-to-ambient thermal resistance under natural convection is obtained in a simulation on a JEDEC-standard, high-K board, as specified in JESD51-7, in an environment described in JESD51-2a.

(3) The junction-to-case (top) thermal resistance is obtained by simulating a cold plate test on the package top. No specific JEDEC-standard test exists, but a close description can be found in the ANSI SEMI standard G30-88.

(4) The junction-to-board thermal resistance is obtained by simulating in an environment with a ring cold plate fixture to control the PCB temperature, as described in JESD51-8.

(5) The junction-to-top characterization parameter, ψ<sub>JT</sub>, estimates the junction temperature of a device in a real system and is extracted from the simulation data for obtaining θ<sub>JA</sub>, using a procedure described in JESD51-2a (sections 6 and 7).

(6) The junction-to-board characterization parameter, ψ<sub>JB</sub>, estimates the junction temperature of a device in a real system and is extracted from the simulation data for obtaining θ<sub>JA</sub>, using a procedure described in JESD51-2a (sections 6 and 7).

(7) The junction-to-case (bottom) thermal resistance is obtained by simulating a cold plate test on the exposed (power) pad. No specific JEDEC standard test exists, but a close description can be found in the ANSI SEMI standard G30-88.

## ELECTRICAL CHARACTERISTICS

Over operating free-air temperature range,  $V_{IN} = 3\text{ V} - 20\text{ V}$ ,  $\overline{EN} = 0\text{ V}$ ,  $\overline{FLT} = \text{open}$ ,  $R_{(RLIM)} = 40.2\text{ k}\Omega$ , No external capacitors are connected to either GATE or OUT, (unless otherwise noted)

PARAMETER		TEST CONDITIONS	MIN	TYP	MAX	UNIT
<b>IN</b>						
	UVLO	$V_{IN} \uparrow$	2.60	2.75	2.9	V
		Hysteresis		100		mV
	Bias current	$\overline{EN} = 2.4\text{ V}$		2.5	4	mA
		$\overline{EN} = 0\text{ V}$		3.3	5	
<b>OUT</b>						
	RON	$R_{(VIN-VOUT)}$ , $I_{(VOUT)} < I_{(RLIM)}$ , $1\text{ A} \leq I_{(VOUT)} \leq 4.5\text{ A}$		29.5	42	mΩ
	Power limit	$V_{IN}: 12\text{ V}$ , $C_{OUT} = 1000\text{ }\mu\text{F}$ , $\overline{EN}: 3\text{ V} \rightarrow 0\text{ V}$	3	5	7.5	W
	Reverse diode voltage	$V_{OUT} > V_{IN}$ , $\overline{EN} = 5\text{ V}$ , $I_{IN} = -1\text{ A}$		0.77	1	V
<b>ILIM</b>						
	current-limit program $I_{VOUT}$ , $V_{(VIN - OUT)} = 0.3\text{ V}$ , pulsed test	$R_{(RLIM)} = 237\text{ k}\Omega$	0.5	0.82	1.1	A
		$R_{(RLIM)} = 200\text{ k}\Omega$	0.75	1	1.25	
		$R_{(RLIM)} = 100\text{ k}\Omega$	1.75	2	2.25	
		$R_{(RLIM)} = 66.5\text{ k}\Omega$	2.65	3	3.3	
		$R_{(RLIM)} = 40.2\text{ k}\Omega$	4.5	5	5.5	
		$R_{(RLIM)} = 29.4\text{ k}\Omega$	5.7	6.5	7.3	
<b>EN</b>						
	Threshold voltage	$V_{(\overline{EN})}$ falling	1.1	1.35		V
		$V_{(\overline{EN})}$ rising		1.5	1.75	
		Hysteresis		150		mV
	Input bias current	$V_{(\overline{EN})} = 2.4\text{ V}$ (sinking)	-1.5	-1	0.5	μA
		$V_{(\overline{EN})} = 0.2\text{ V}$ (sourcing)	-2	-1	0.5	
	Turn on propagation delay	$V_{IN} = 3.3\text{ V}$ , $I_{LOAD} = 1\text{ A}$ , $V_{(\overline{EN})}: 2.4\text{ V} \rightarrow 0.2\text{ V}$ , till $I_{GATE}$ changes direction.		10		μs
	Turn off propagation delay	$V_{IN} = 3.3\text{ V}$ , $I_{LOAD} = 1\text{ A}$ , $V_{(\overline{EN})}: 0.2\text{ V} \rightarrow 2.4\text{ V}$ , till $I_{GATE}$ changes direction.		2.5		
<b>FLT</b>						
	$V_{OL}$	$I_{(FLT)} = 1\text{ mA}$ , Fault active (Over Temperature)		0.2	0.4	V
	Leakage current	$V_{(FLT)} = 18\text{ V}$			1	μA
<b>THERMAL SHUTDOWN</b>						
	Thermal shutdown	$T_J$		160		°C
		Hysteresis		20		
<b>GATE</b>						
	Sourcing current	$V_{(GATE-OUT)} = 3.5\text{ V}$ , $V_{(\overline{EN})} = \text{Low}$	8	11	15	μA
	Strong pull down resistor	$V_{(\overline{EN})} = \text{Low}$	10	40	80	Ω
	Weak pull down current	$V_{(\overline{EN})} = \text{Low}$	250	500	750	μA
	Output Voltage, $V_{(GATE-OUT)}$		5.5	6.6	7.5	V

DEVICE INFORMATION

TPS25910 FUNCTIONAL BLOCK DIAGRAM

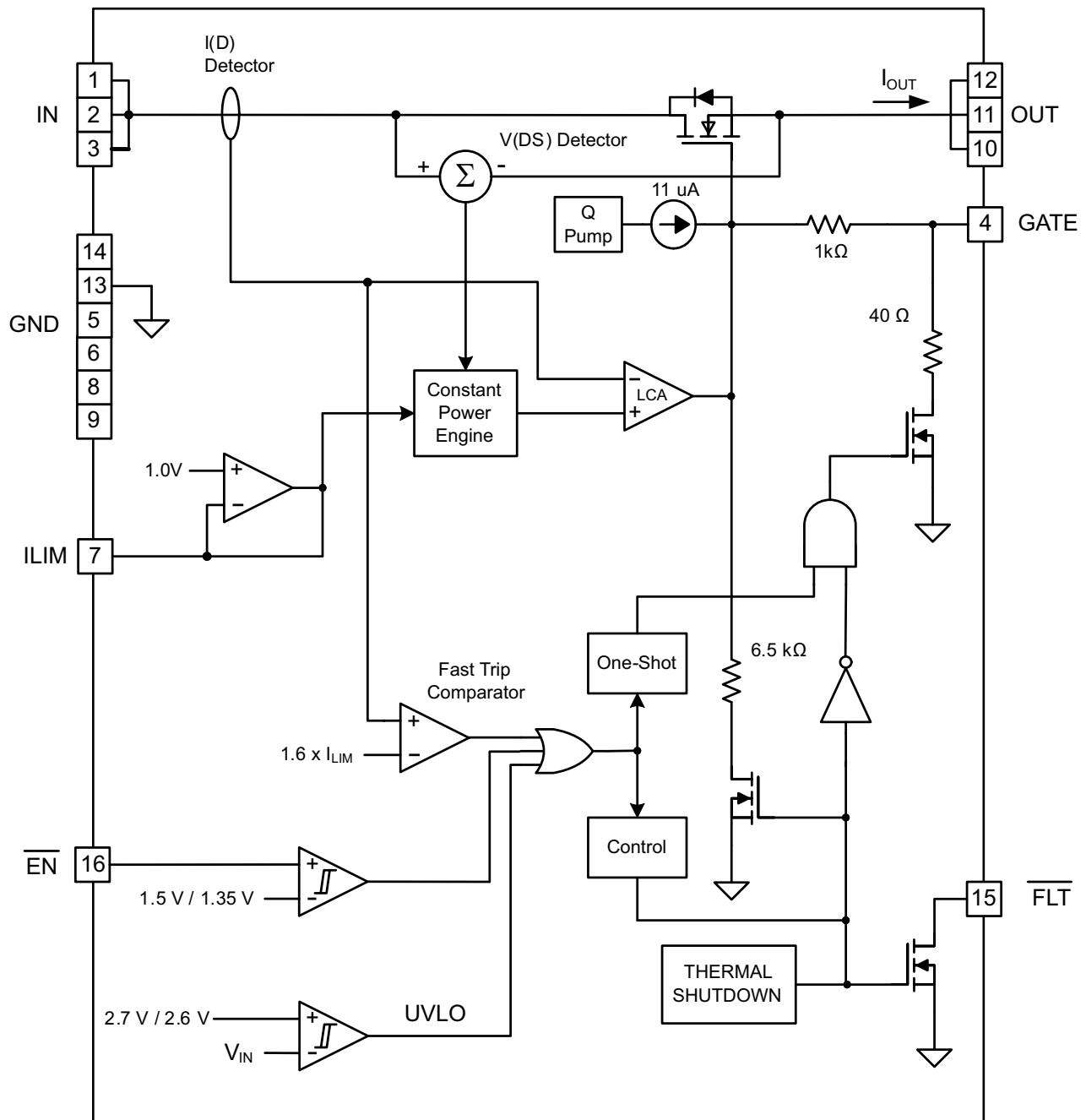
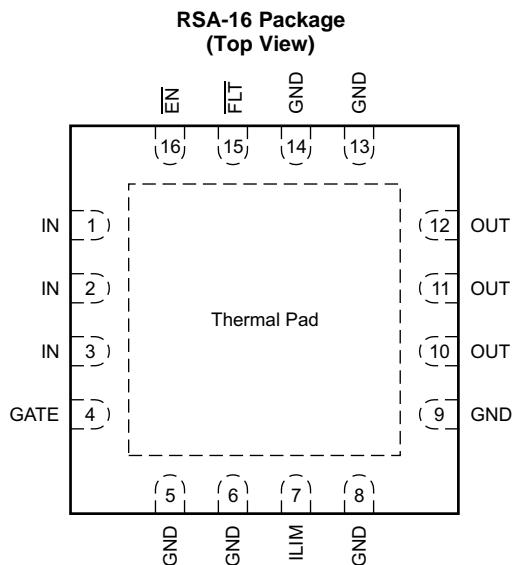

Figure 1. Functional Block Diagram

**TPS25910 PIN ASSIGNMENT**



**PIN FUNCTIONS**

PIN NAME	PIN NUMBER	DESCRIPTION
$\overline{\text{EN}}$	16	Device is enabled when this pin is pulled low.
IN	1, 2, 3	Power In and control supply voltage.
GATE	4	If the chip die temperature exceeds the OTSD rising threshold, GATE is pulled down to GND by a 7.5KOhm resistor.
ILIM	7	A resistor to ground sets the current-limit level.
GND	5, 6, 8, 9, 13, 14	GND
OUT	10, 11, 12	Output to the load.
$\overline{\text{FLT}}$	15	Fault low indicates that the internal pass FET junction temperature exceeds the thermal shutdown threshold

## PIN DESCRIPTION

**FLT:** Open-drain output that pulls low during thermal shutdown.  $\overline{\text{FLT}}$  activates when device thermally shuts down and deactivates when die temperature cools down below the device thermal protection threshold and the device ends thermal shutdown cycle.  $\overline{\text{FLT}}$  becomes operational before UV, when  $V_{\text{IN}}$  is greater than 1 V.

**GND:** This is the most negative voltage in the circuit and is used as reference for all voltage measurements unless otherwise specified. All the GND pins must be connected to system power supply negative return point

**GATE:** Output that provides gate drive for the internal pass FET. Its sourcing current is about 11  $\mu\text{A}$ . An internal clamp prevents GATE from rising 6.6 V above OUT.  $C_{\text{INT}}$  is 200 pF.

The GATE pin is disabled by the following mechanisms:

1. When  $\overline{\text{EN}}$  is above its rising threshold, GATE is pulled down by a 40- $\Omega$  resistor connecting to GND for approximately 50  $\mu\text{s}$ . Then, a 7.5-k $\Omega$  resistor ties GATE to GND to ensure the GATE is off.
2. When  $V_{\text{IN}}$  drops below the UVLO threshold, GATE is pulled down by a 40- $\Omega$  resistor connecting to GND for approximately 50  $\mu\text{s}$ . Then, a 7.5-k $\Omega$  resistor ties GATE to GND to ensure the GATE is off.
3. When short circuit fault occurs, GATE is pulled down by a 40- $\Omega$  resistor connecting to GND for approximately 50  $\mu\text{s}$ . Then, a 500- $\mu\text{A}$  current source continues to pull down on the GATE.
4. If the chip die temperature exceeds the OTSD rising threshold, GATE is pulled down to GND by a 7.5-k $\Omega$  resistor.

An external capacitor can be connected from GATE pin to GND pin to create linear inrush profile. The slew rate of the inrush can be controlled by a different capacitor value.

$$I_{\text{CHARGE}} = (C_{\text{EXT}} + C_{\text{INT}}) \frac{dV_{\text{OUT}}}{dt}$$

where

- $I_{\text{CHARGE}}$  is 11  $\mu\text{A}$  (typical)
  - $C_{\text{INT}}$ , the equivalent gate input capacitance of the internal FET (200 pF typical)
- (1)

**ILIM:** A resistor connected from this pin to ground sets  $I_{\text{LIM}}$ .  $R_{\text{LIM}}$  is set by the formula:

$$R_{\text{LIM}} = \frac{197.388}{I_{\text{LIM}}^{0.976944}} \quad \text{for currents below 2 A where } R_{\text{LIM}} \text{ is in k}\Omega. \quad (2)$$

$$R_{\text{LIM}} = \frac{205.62}{I_{\text{LIM}}^{1.02912}} \quad \text{for currents above 2 A where } R_{\text{LIM}} \text{ is in k}\Omega. \quad (3)$$

**EN:** When this pin is pulled low, the device is enabled. The input threshold is hysteretic, allowing the user to program a startup delay with an external RC circuit.  $\overline{\text{EN}}$  is pulled to  $V_{\text{IN}}$  by a 10-M $\Omega$  resistor, pulled to GND by 16.8 M $\Omega$  and is clamped to ground by a 7-V Zener diode. Because high impedance pullup and or down resistors are used to reduce current draw, any external FET controlling this pin must be low leakage.

**IN:** Input voltage to the TPS25910 device. The recommended operating voltage range is 3 V to 20 V. All  $V_{\text{IN}}$  pins must be connected together and to the power source.

**OUT:** Output connection for the TPS25910 device. When switched on, the output voltage is approximately:

$$V_{\text{OUT}} = V_{\text{IN}} - 0.04 \times I_{\text{OUT}} \quad (4)$$

All OUT pins must be connected together and to the load.

TYPICAL CHARACTERISTICS

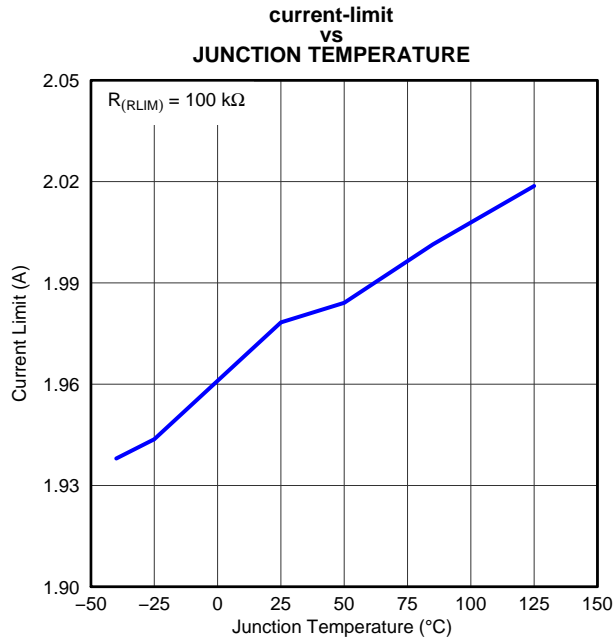

Figure 2.

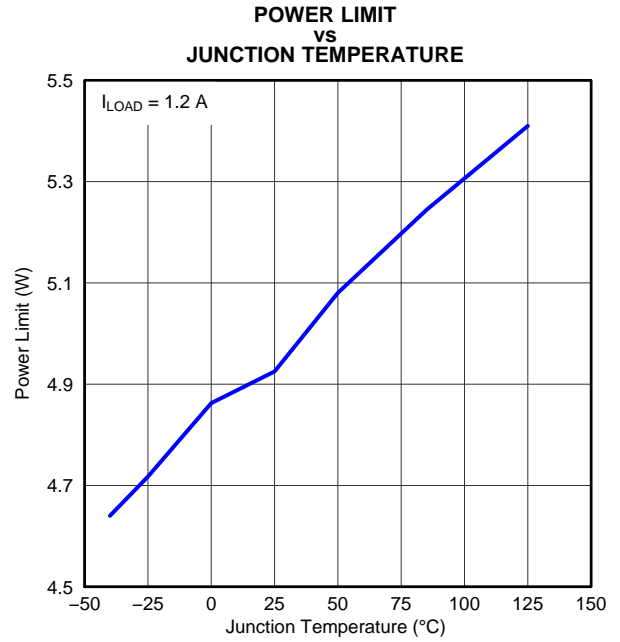

Figure 3.

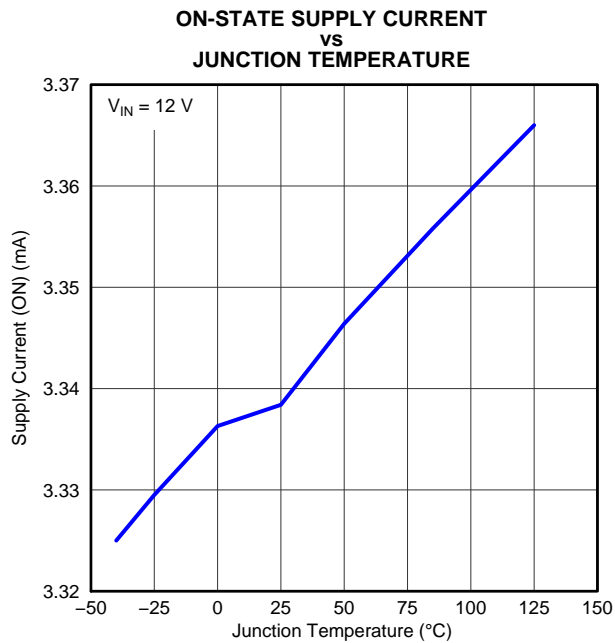

Figure 4.

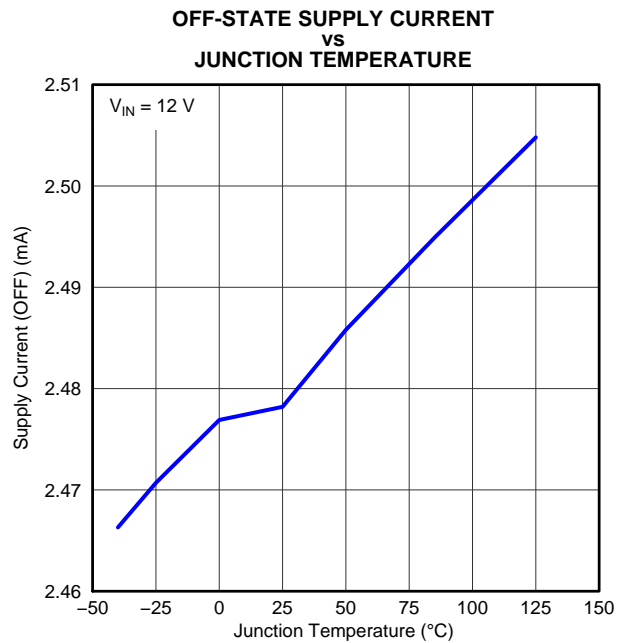

Figure 5.

## APPLICATION INFORMATION

### Programming the Current-Limit Threshold

The over-current threshold is user programmable via an external resistor. The TPS25910 device uses an internal regulation loop to provide a regulated voltage on the ILIM pin. The current-limit threshold is proportional to the current sourced out of ILIM. The recommended 1% resistor range for  $R_{LIM}$  is  $0\text{ k}\Omega \leq R_{LIM} \leq 237\text{ k}\Omega$  to ensure stability of the internal regulation loop. Many applications require that the minimum current-limit is above a certain current level or that the maximum current-limit is below a certain current level, so it is important to consider the tolerance of the over-current threshold when selecting a value for  $R_{LIM}$ . Consult the [ELECTRICAL CHARACTERISTICS](#) table for specific current-limit settings. The traces routing the  $R_{LIM}$  resistor to the TPS25910 device must be as short as possible to reduce parasitic effects on the current-limit accuracy.

Equation 5 through Equation 7 can be used to estimate current-limit below 2 A:

$$I_{LIM(min)} = \frac{1051.9}{R_{LIM(max)}^{1.3854}} \quad (5)$$

$$I_{LIM(typ)} = \frac{223.61}{R_{LIM(typ)}^{1.0236}} \quad (6)$$

$$I_{LIM(max)} = \frac{104.95}{R_{LIM(min)}^{0.8347}} \quad (7)$$

Equation 8 through Equation 10 can be used to estimate current-limit above 2 A:

$$I_{LIM(min)} = \frac{161.24}{R_{LIM(max)}^{0.9796}} \quad (8)$$

$$I_{LIM(typ)} = \frac{176.85}{R_{LIM(typ)}^{0.9717}} \quad (9)$$

$$I_{LIM(max)} = \frac{194.81}{R_{LIM(min)}^{0.9694}} \quad (10)$$

where

- $R_{LIM(max)}$  is the maximum resistor value in factoring in error
- $R_{LIM(typ)}$  is the typical resistor value
- $R_{LIM(min)}$  is the minimum resistor value factoring in error

All resistor values are represented in k $\Omega$ . For example, a 100-k $\Omega$ , 1% resistor would have the following values:

- $R_{LIM(min)} = 99\text{ k}\Omega$
- $R_{LIM(typ)} = 100\text{ k}\Omega$
- $R_{LIM(max)} = 101\text{ k}\Omega$

A plot of the current-limit threshold versus  $R_{ILIM}$  using equations Equation 5 through Equation 10 above is shown in Figure 6.

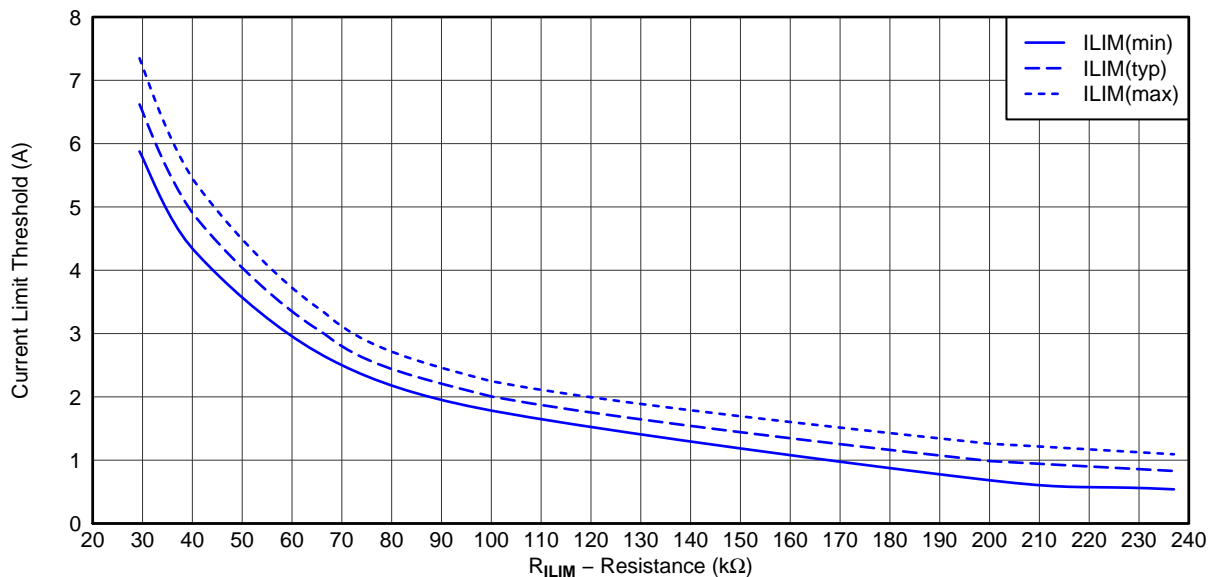

Figure 6. Current-Limit Threshold Versus  $R_{ILIM}$

### Slew Rate Control Using C<sub>GATE</sub>

The TPS25910 device can be used with applications that require constant turn-on currents. The current is controlled by a single capacitor from the GATE terminal to ground. The TPS25910 internal MOSFET appears to operate as a source follower (following the gate voltage) in this implementation. Choose a time to charge,  $\Delta t$ , based on the output capacitor, input voltage  $V_I$ , and desired charge current,  $I_{CHARGE}$ . Select the device load to be less than 5 W /  $V_{IN}$ .

$$\Delta t = \frac{C_{LOAD} \times V_{IN}}{I_{C-LOAD}} \tag{11}$$

To select the gate capacitance:

$$C_{EXT} = I_{CHARGE} \times \frac{\Delta t}{V_{IN}} - C_{INT} \tag{12}$$

- $I_{CHARGE} = 11 \mu A$
- $C_{INT} = 200 \text{ pF}$  (typical)

Figure 7 and Figure 8 illustrate the effects of  $C_{EXT} = 0.1 \mu F$  on inrush current using TPS25910EVM-088.

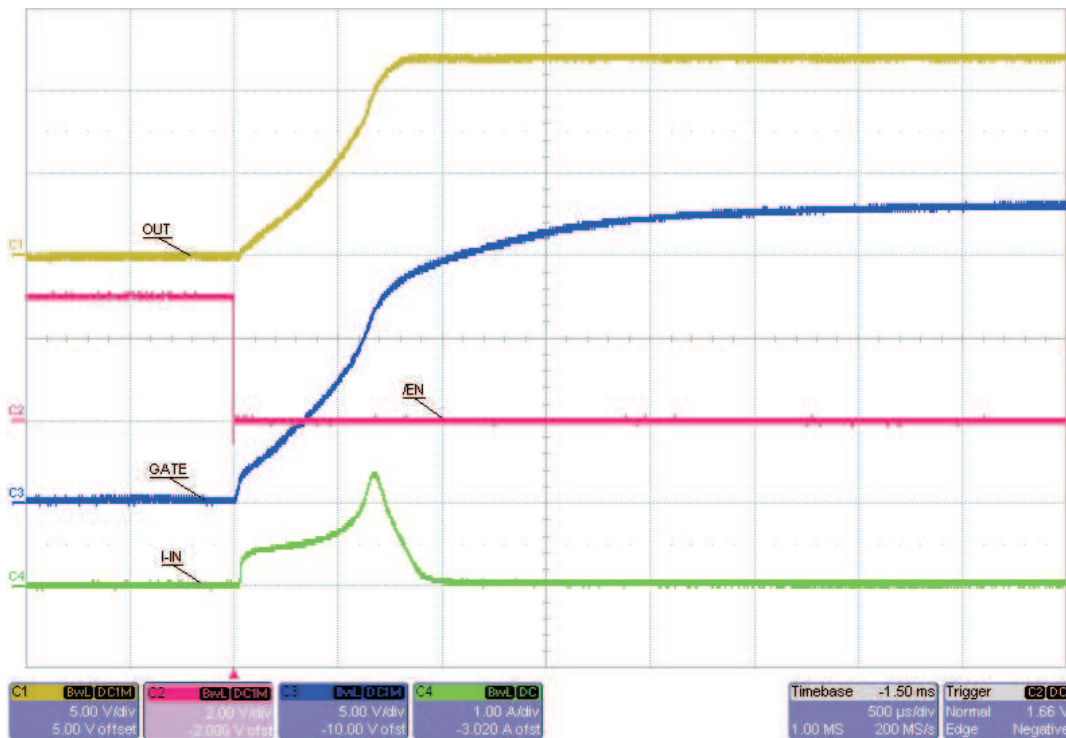

Figure 7. Typical Power Limited Inrush Start Up (No C<sub>EXT</sub>)

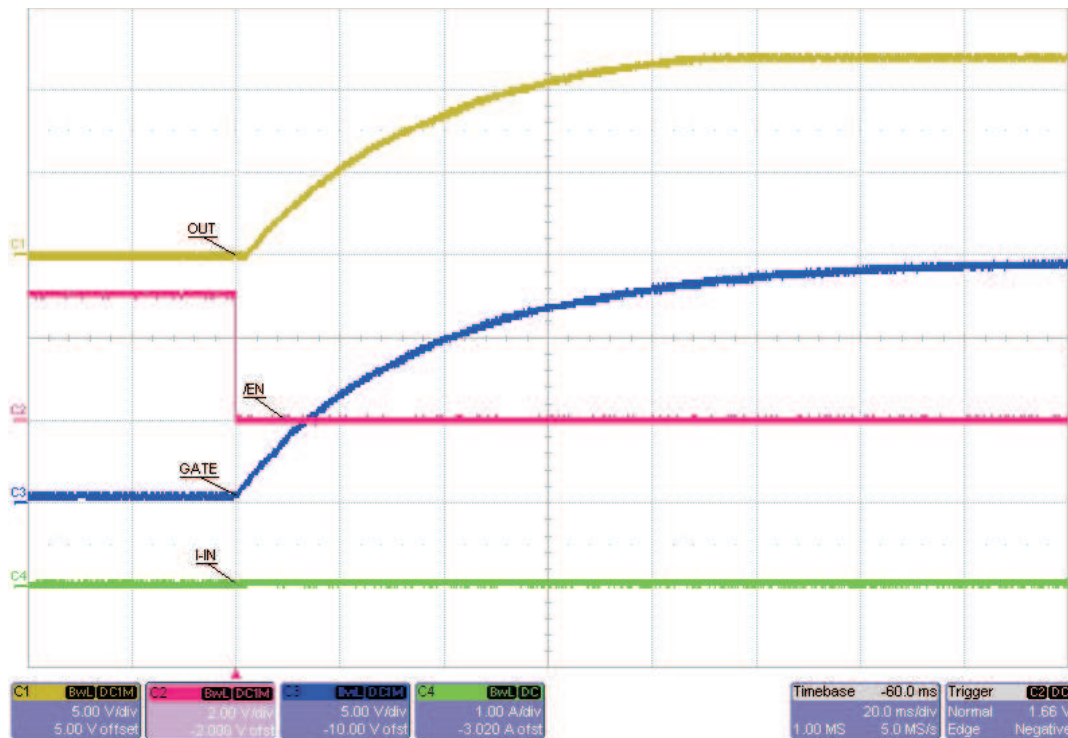

Figure 8. Start-Up With Slew Rate Control ( $C_{EXT} = 0.1 \mu F$ )

## Thermal Sense

The TPS25910 self protects by using a thermal sensing circuit that monitors the operating temperature of the power switch and disables operation if the temperature exceeds the thermal shutdown condition (160°C typical). The TPS25910 device operates in power-limit mode during an overload condition and increases the voltage drop across power switch. The thermal sensor turns off the power switch when the die temperature exceeds 160°C. Hysteresis is built into the thermal sensor, and the switch turns on after the device has cooled approximately 20°C. [Figure 9](#) below illustrates the thermal behavior during output overload.

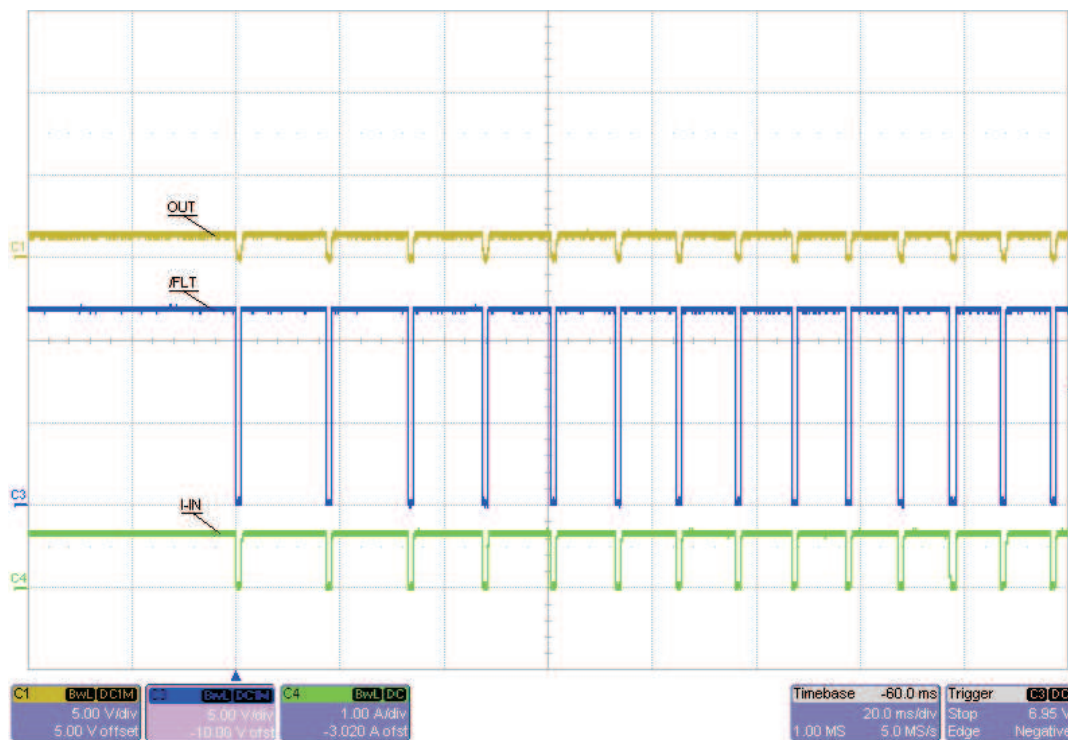

Figure 9. Thermal Sense Behavior

### Back-to-Back (B2B) FET Operation

Many applications require reverse current blocking (from load to input source) so that pending system activities can be completed (such as writing important data to non-volatile memory) prior to power down or during brown out. The TPS25910 device provides the GATE pin externally for slew rate control, but this external connection can also be used to control an external blocking MOSFET, Q1 as shown in Figure 10.

As  $V_{IN}$  drops during input power removal, the comparator circuit de-asserts ENb, GATE falls, and both the TPS25910 internal MOSFET and Q1 is turned off and block any current flow from  $V_{LOAD}$  to  $V_{IN}$ .  $C_{LOAD}$  can then be chosen to furnish the required load current for long enough to complete the required power down system activities.

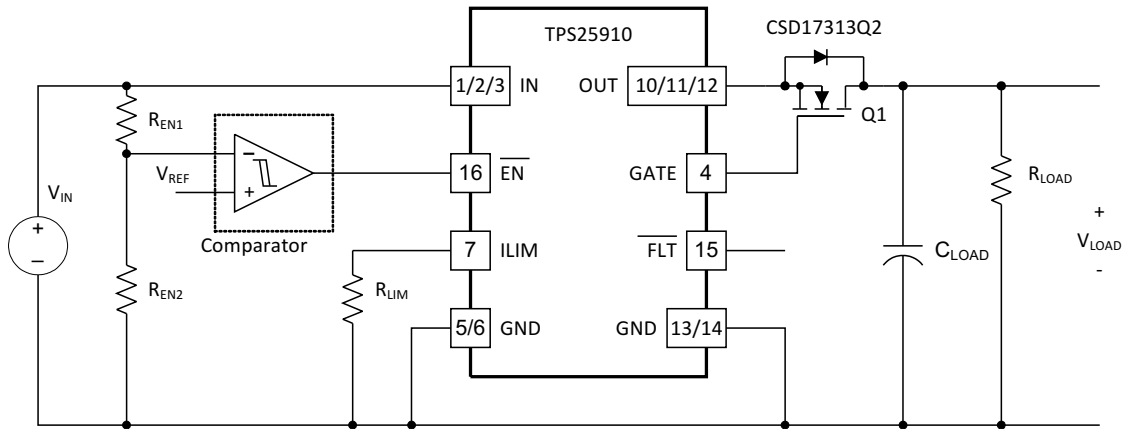

Figure 10. B2B Implementation

**NOTE**

Connecting the load voltage to the non-inverting input of the external comparator can provide a simple ORing function that prevents holdup energy in  $C_{LOAD}$  from discharging through the TPS25910 device to  $V_{IN(source)}$  when  $V_{IN(source)}$  droops or collapses.

Circuit operation is illustrated in Figure 11 and Figure 12. Figure 11 shows the power down event with no load at the output. When  $V_{IN}$  drops to approximately 10 V (threshold of comparator circuit), ENb is de-asserted and GATE falls and enables reverse current blocking. The voltage on  $C_{LOAD}$  then stops following  $V_{IN}$  and remains flat for a long duration.

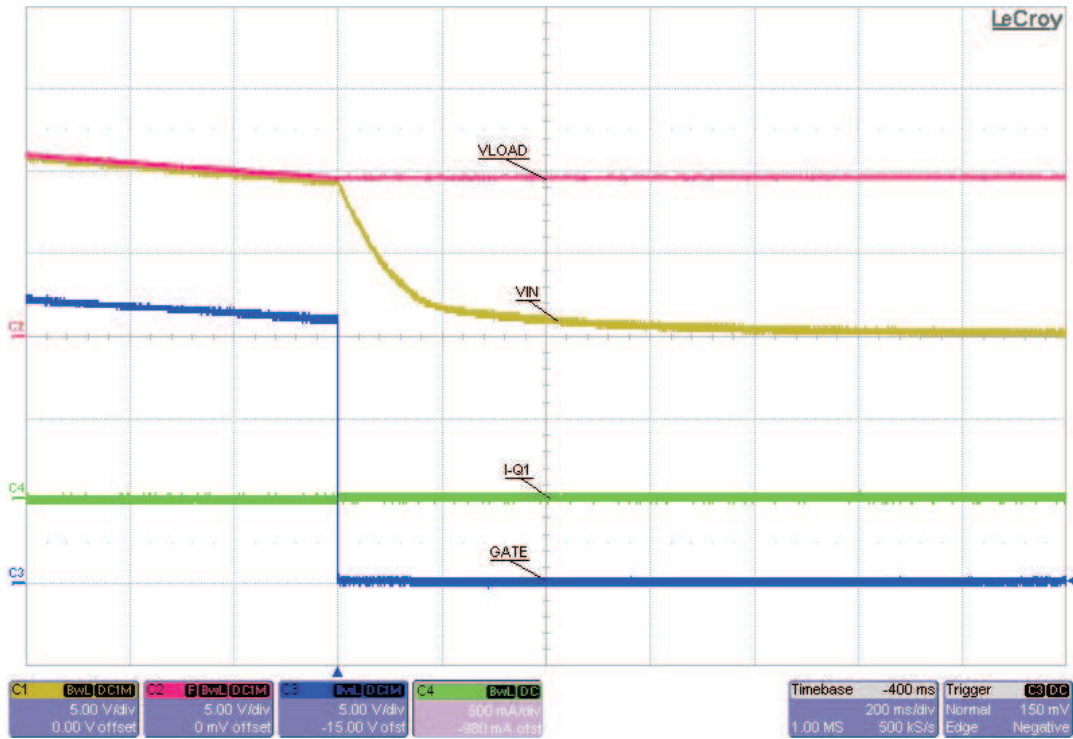

Figure 11. B2B Performance with No-Load

Figure 12 illustrates the power down event with a 200-mA load. As  $V_{IN}$  starts to fall, the output load is supplied by  $C_{LOAD}$ .  $C_{LOAD}$  must be large enough to support  $V_{LOAD}$  for long enough for the power down activities to complete. For the case shown in Figure 12,  $C_{LOAD}$  is a 3900- $\mu\text{F}$  capacitor and can support a droop from approximately 10 V to approximately 5 V for approximately 170 ms.

The TPS3700DDC (dual comparator with wide input voltage range) can be used for the B2B comparator circuit shown in Figure 10. Only one comparator is needed, but the second comparator can be utilized as either a power good flag or as a notification to the system load that a brownout or power down event is about to occur.

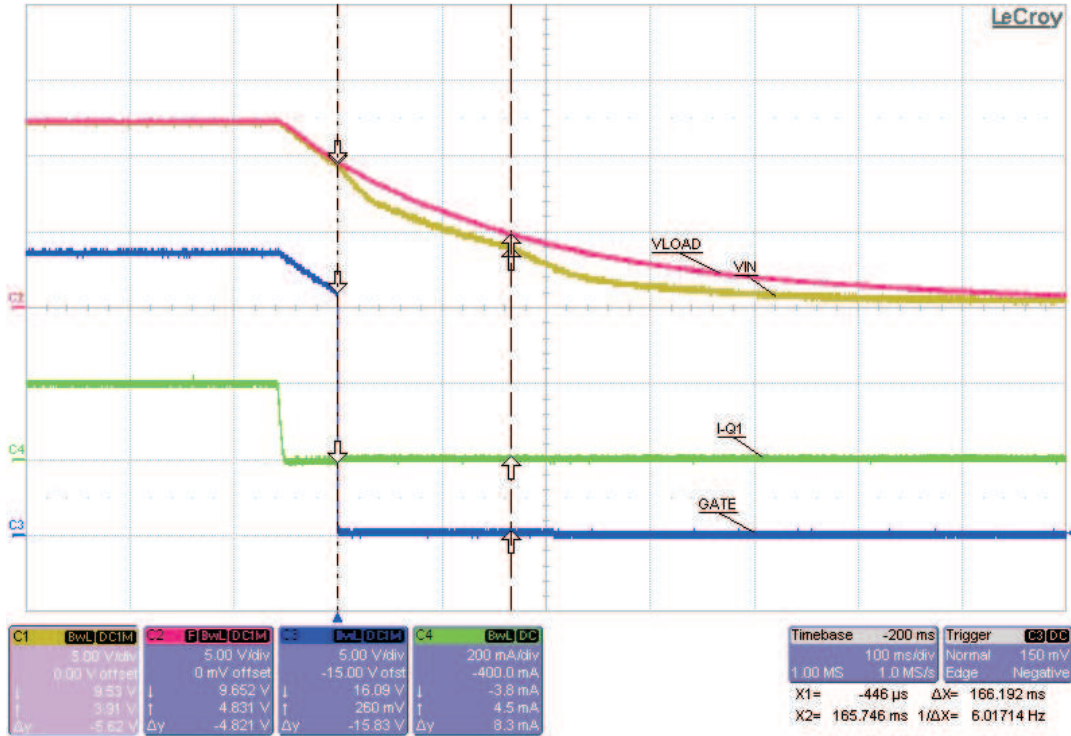

Figure 12. B2B Performance with 200-mA Load

## Maximum Load at Startup

The power limiting function of the TPS25910 device provides effective protection for the internal FET. Expectedly, there is a supply voltage dependent maximum load which the device is able to power up. Loads above this level can cause the device to shut off current before startup is complete. Neglecting any load capacitance, the maximum load (minimum load resistance) is calculated using [Equation 13](#);

$$R_{\text{MIN}} = \frac{V_{\text{IN}}^2}{12} \quad (13)$$

Adding load capacitance may reduce the maximum load which can be present at start up.

If  $\overline{\text{EN}}$  is tied to GND at startup and IN does not ramp quickly, the TPS25910 device can momentarily turn off then on during startup. This can happen if a capacitive load pulls down the input voltage below the UV threshold. If necessary, this can be avoided by delaying the  $\overline{\text{EN}}$  assertion until VIN is fully up.

## Transient Protection

The need for transient protection in conjunction with hot-swap controllers should always be considered. When the TPS25910 device interrupts current flow, input inductance generates a positive voltage spike on the input and output inductance generates a negative voltage spike on the output. Such transients can easily exceed twice the supply voltage if steps are not taken to address the issue. Typical methods for addressing transients include;

- Minimizing lead length/inductance into and out of the device.
- Transient Voltage Suppressors (TVS) on the input to absorb inductive spikes.
- Schottky diode across the output to absorb negative spikes.
- A combination of ceramic and electrolytic capacitors on the input and output to absorb energy.

The following equation estimates the magnitude of these voltage spikes:

Where;

$$V_{\text{SPIKE(absolute)}} = V_{\text{NOM}} + I_{\text{LOAD}} \times \sqrt{\frac{L}{C}}$$

- $V_{\text{NOM}}$  equals the nominal supply voltage
- $I_{\text{LOAD}}$  equals the load current
- C equals the capacitance present at the input or output of the TPS25910 device
- L equals the effective inductance seen looking into the source or the load

(14)

The inductance because of a straight length of wire equals approximately.

Where;

$$L_{\text{straightwire}} \approx 0.2 \times L \times \ln\left(\frac{4 \times L}{D} - 0.75\right) \text{ (nH)}$$

- L equals the length of the wire
- D equals wire diameter

(15)

Some applications may require the addition of a TVS to prevent transients from exceeding the absolute ratings if sufficient capacitance cannot be included.

## REVISION HISTORY

Changes from Original (September 2012) to Revision A	Page
• Changed the 12-V, 4.75-A APPLICATION image .....	1
• Changed <a href="#">Equation 3</a> text From: below 2 A where $R_{LIM}$ is in k $\Omega$ . To: above 2 A where $R_{LIM}$ is in k $\Omega$ . .....	7
• Changed <a href="#">Equation 12</a> .....	11
• Changed <a href="#">Figure 10</a> .....	14
Changes from Revision A (September 2012) to Revision B	Page
• Changed <a href="#">Figure 1</a> LCA polarity symbols .....	5
• Changed <a href="#">Figure 10</a> Q1 connection .....	14
Changes from Revision B (March, 2013) to Revision C	Page
• Added Bullet: <b>UL Listed - File Number E169910</b> to the Features section. ....	1
• Added Bullet: <b>CB Certified</b> to the Features section. ....	1
Changes from Revision C (May 2013) to Revision D	Page
• Deleted the minimum voltage from the voltage range listed in the document title, features list and description .....	1
• Added 6.5-A to document title .....	1
• Changed <i>listed</i> to <i>recognized</i> in last <i>FEATURES</i> bullet .....	1
• Added 2367 to UL number in the <i>FEATURES</i> list. Moved File Number to same list item as UL Recognized .....	1
• Added PCIE and Fan Control to the <i>APPLICATIONS</i> list .....	1
• Deleted <i>where the load is powered by busses up to 20 V</i> from the first paragraph of the <i>DESCRIPTION</i> and replaced it with UV turn-on threshold and bus voltage text .....	1
• Deleted <i>ORDERING INFORMATION</i> table .....	2

## PACKAGING INFORMATION

Orderable Device	Status (1)	Package Type	Package Drawing	Pins	Package Qty	Eco Plan (2)	Lead/Ball Finish	MSL Peak Temp (3)	Op Temp (°C)	Device Marking (4/5)	Samples
TPS25910RSAR	ACTIVE	QFN	RSA	16	3000	Green (RoHS & no Sb/Br)	CU NIPDAU	Level-2-260C-1 YEAR	-40 to 125	TPS 25910	<a href="#">Samples</a>
TPS25910RSAT	ACTIVE	QFN	RSA	16	250	Green (RoHS & no Sb/Br)	CU NIPDAU	Level-2-260C-1 YEAR	-40 to 125	TPS 25910	<a href="#">Samples</a>

(1) The marketing status values are defined as follows:

**ACTIVE:** Product device recommended for new designs.

**LIFEBUY:** TI has announced that the device will be discontinued, and a lifetime-buy period is in effect.

**NRND:** Not recommended for new designs. Device is in production to support existing customers, but TI does not recommend using this part in a new design.

**PREVIEW:** Device has been announced but is not in production. Samples may or may not be available.

**OBSOLETE:** TI has discontinued the production of the device.

(2) Eco Plan - The planned eco-friendly classification: Pb-Free (RoHS), Pb-Free (RoHS Exempt), or Green (RoHS & no Sb/Br) - please check <http://www.ti.com/productcontent> for the latest availability information and additional product content details.

**TBD:** The Pb-Free/Green conversion plan has not been defined.

**Pb-Free (RoHS):** TI's terms "Lead-Free" or "Pb-Free" mean semiconductor products that are compatible with the current RoHS requirements for all 6 substances, including the requirement that lead not exceed 0.1% by weight in homogeneous materials. Where designed to be soldered at high temperatures, TI Pb-Free products are suitable for use in specified lead-free processes.

**Pb-Free (RoHS Exempt):** This component has a RoHS exemption for either 1) lead-based flip-chip solder bumps used between the die and package, or 2) lead-based die adhesive used between the die and leadframe. The component is otherwise considered Pb-Free (RoHS compatible) as defined above.

**Green (RoHS & no Sb/Br):** TI defines "Green" to mean Pb-Free (RoHS compatible), and free of Bromine (Br) and Antimony (Sb) based flame retardants (Br or Sb do not exceed 0.1% by weight in homogeneous material)

(3) MSL, Peak Temp. -- The Moisture Sensitivity Level rating according to the JEDEC industry standard classifications, and peak solder temperature.

(4) There may be additional marking, which relates to the logo, the lot trace code information, or the environmental category on the device.

(5) Multiple Device Markings will be inside parentheses. Only one Device Marking contained in parentheses and separated by a "~" will appear on a device. If a line is indented then it is a continuation of the previous line and the two combined represent the entire Device Marking for that device.

**Important Information and Disclaimer:** The information provided on this page represents TI's knowledge and belief as of the date that it is provided. TI bases its knowledge and belief on information provided by third parties, and makes no representation or warranty as to the accuracy of such information. Efforts are underway to better integrate information from third parties. TI has taken and continues to take reasonable steps to provide representative and accurate information but may not have conducted destructive testing or chemical analysis on incoming materials and chemicals. TI and TI suppliers consider certain information to be proprietary, and thus CAS numbers and other limited information may not be available for release.

In no event shall TI's liability arising out of such information exceed the total purchase price of the TI part(s) at issue in this document sold by TI to Customer on an annual basis.

**TAPE AND REEL INFORMATION**

**QUADRANT ASSIGNMENTS FOR PIN 1 ORIENTATION IN TAPE**

\*All dimensions are nominal

Device	Package Type	Package Drawing	Pins	SPQ	Reel Diameter (mm)	Reel Width W1 (mm)	A0 (mm)	B0 (mm)	K0 (mm)	P1 (mm)	W (mm)	Pin1 Quadrant
TPS25910RSAR	QFN	RSA	16	3000	330.0	12.4	4.25	4.25	1.15	8.0	12.0	Q2
TPS25910RSAT	QFN	RSA	16	250	180.0	12.4	4.25	4.25	1.15	8.0	12.0	Q2

**TAPE AND REEL BOX DIMENSIONS**

\*All dimensions are nominal

Device	Package Type	Package Drawing	Pins	SPQ	Length (mm)	Width (mm)	Height (mm)
TPS25910RSAR	QFN	RSA	16	3000	367.0	367.0	35.0
TPS25910RSAT	QFN	RSA	16	250	210.0	185.0	35.0

RSA (S-PVQFN-N16)

PLASTIC QUAD FLATPACK NO-LEAD

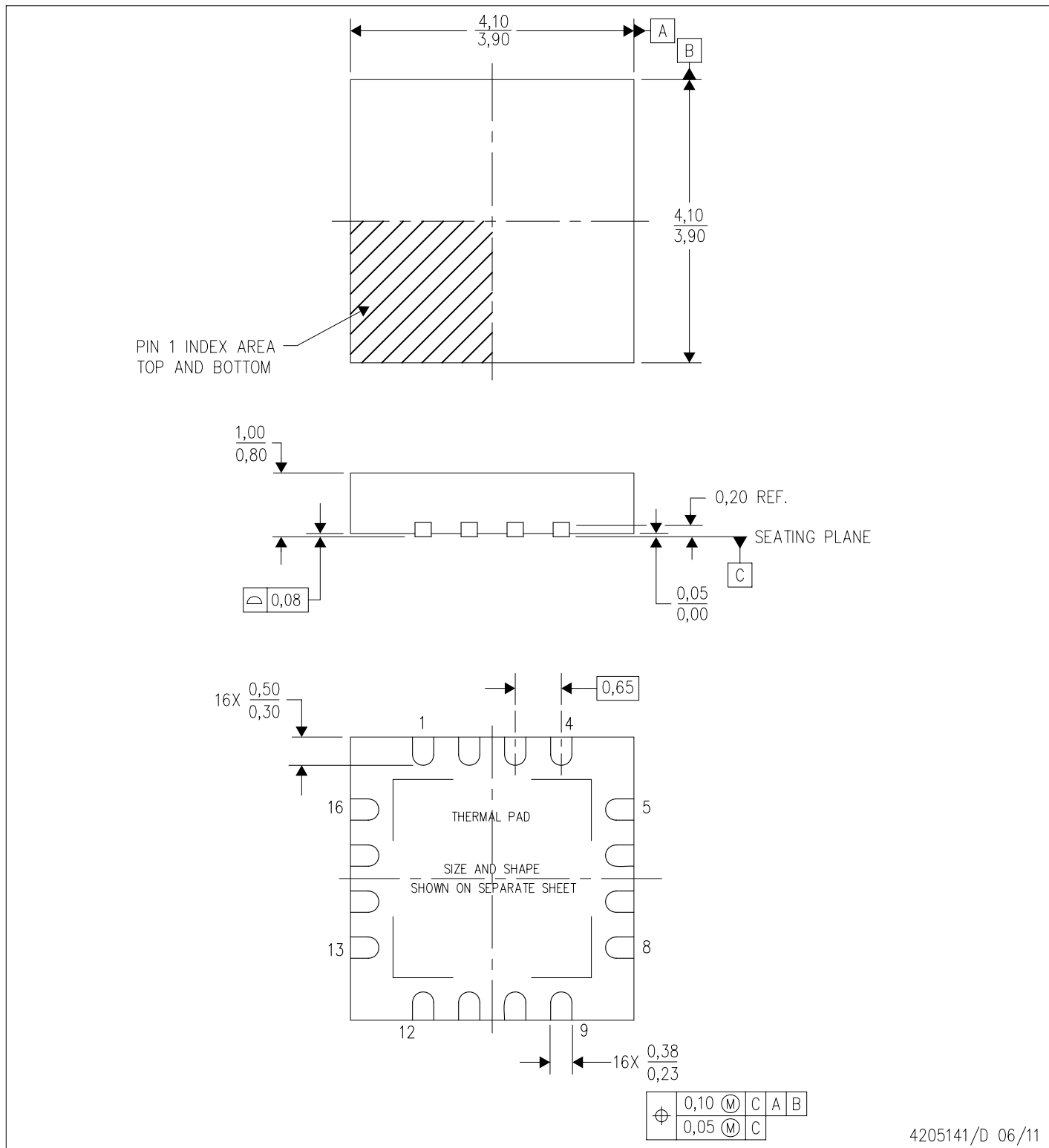

- NOTES:
- All linear dimensions are in millimeters. Dimensioning and tolerancing per ASME Y14.5M-1994.
  - This drawing is subject to change without notice.
  - Quad Flatpack, No-leads (QFN) package configuration.
  - The package thermal pad must be soldered to the board for thermal and mechanical performance.
  - See the additional figure in the Product Data Sheet for details regarding the exposed thermal pad features and dimensions.
  - Falls within JEDEC MO-220.

**THERMAL INFORMATION**

This package incorporates an exposed thermal pad that is designed to be attached directly to an external heatsink. The thermal pad must be soldered directly to the printed circuit board (PCB). After soldering, the PCB can be used as a heatsink. In addition, through the use of thermal vias, the thermal pad can be attached directly to the appropriate copper plane shown in the electrical schematic for the device, or alternatively, can be attached to a special heatsink structure designed into the PCB. This design optimizes the heat transfer from the integrated circuit (IC).

For information on the Quad Flatpack No-Lead (QFN) package and its advantages, refer to Application Report, QFN/SON PCB Attachment, Texas Instruments Literature No. SLUA271. This document is available at [www.ti.com](http://www.ti.com).

The exposed thermal pad dimensions for this package are shown in the following illustration.

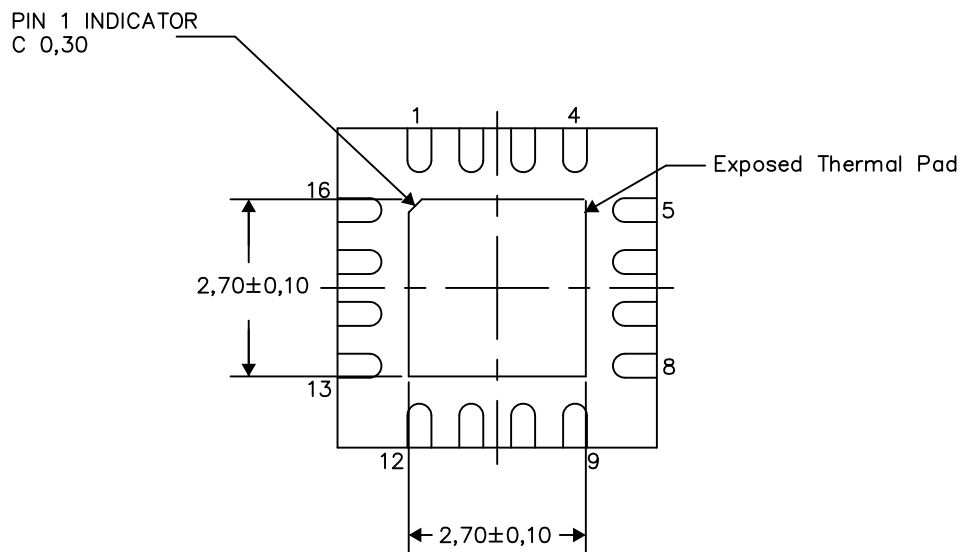

Bottom View

Exposed Thermal Pad Dimensions

4206364/N 07/13

**NOTES:**

A. All linear dimensions are in millimeters

RSA (S-PVQFN-N16)

PLASTIC QUAD FLATPACK NO-LEAD

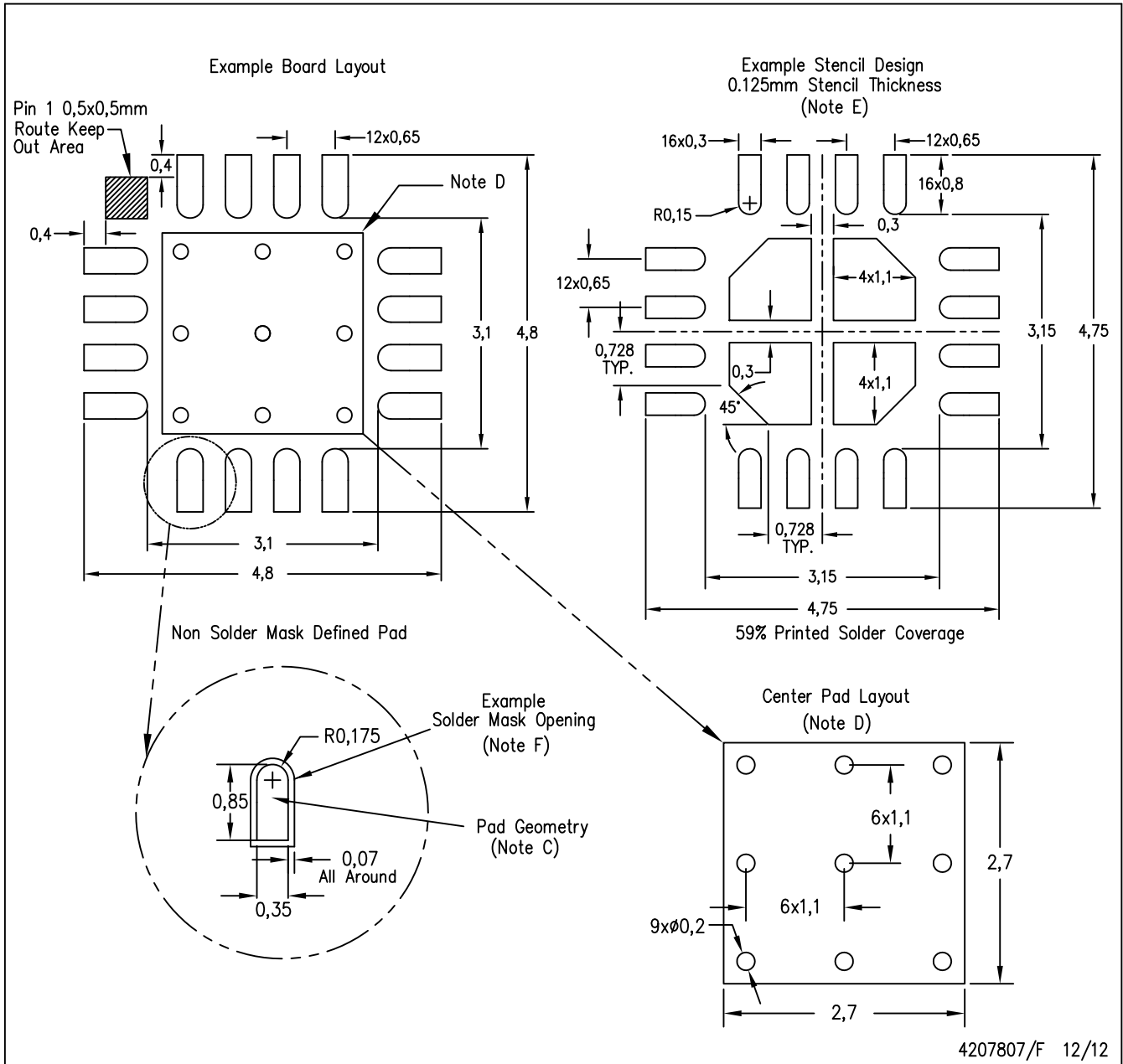

- NOTES:
- A. All linear dimensions are in millimeters.
  - B. This drawing is subject to change without notice.
  - C. Publication IPC-7351 is recommended for alternate designs.
  - D. This package is designed to be soldered to a thermal pad on the board. Refer to Application Note, QFN Packages, Texas Instruments Literature No. SLUA271, and also the Product Data Sheets for specific thermal information, via requirements, and recommended board layout. These documents are available at [www.ti.com](http://www.ti.com) <<http://www.ti.com>>.
  - E. Laser cutting apertures with trapezoidal walls and also rounding corners will offer better paste release. Customers should contact their board assembly site for stencil design recommendations. Refer to IPC 7525 for stencil design considerations.
  - F. Customers should contact their board fabrication site for solder mask tolerances.

## IMPORTANT NOTICE

Texas Instruments Incorporated and its subsidiaries (TI) reserve the right to make corrections, enhancements, improvements and other changes to its semiconductor products and services per JESD46, latest issue, and to discontinue any product or service per JESD48, latest issue. Buyers should obtain the latest relevant information before placing orders and should verify that such information is current and complete. All semiconductor products (also referred to herein as "components") are sold subject to TI's terms and conditions of sale supplied at the time of order acknowledgment.

TI warrants performance of its components to the specifications applicable at the time of sale, in accordance with the warranty in TI's terms and conditions of sale of semiconductor products. Testing and other quality control techniques are used to the extent TI deems necessary to support this warranty. Except where mandated by applicable law, testing of all parameters of each component is not necessarily performed.

TI assumes no liability for applications assistance or the design of Buyers' products. Buyers are responsible for their products and applications using TI components. To minimize the risks associated with Buyers' products and applications, Buyers should provide adequate design and operating safeguards.

TI does not warrant or represent that any license, either express or implied, is granted under any patent right, copyright, mask work right, or other intellectual property right relating to any combination, machine, or process in which TI components or services are used. Information published by TI regarding third-party products or services does not constitute a license to use such products or services or a warranty or endorsement thereof. Use of such information may require a license from a third party under the patents or other intellectual property of the third party, or a license from TI under the patents or other intellectual property of TI.

Reproduction of significant portions of TI information in TI data books or data sheets is permissible only if reproduction is without alteration and is accompanied by all associated warranties, conditions, limitations, and notices. TI is not responsible or liable for such altered documentation. Information of third parties may be subject to additional restrictions.

Resale of TI components or services with statements different from or beyond the parameters stated by TI for that component or service voids all express and any implied warranties for the associated TI component or service and is an unfair and deceptive business practice. TI is not responsible or liable for any such statements.

Buyer acknowledges and agrees that it is solely responsible for compliance with all legal, regulatory and safety-related requirements concerning its products, and any use of TI components in its applications, notwithstanding any applications-related information or support that may be provided by TI. Buyer represents and agrees that it has all the necessary expertise to create and implement safeguards which anticipate dangerous consequences of failures, monitor failures and their consequences, lessen the likelihood of failures that might cause harm and take appropriate remedial actions. Buyer will fully indemnify TI and its representatives against any damages arising out of the use of any TI components in safety-critical applications.

In some cases, TI components may be promoted specifically to facilitate safety-related applications. With such components, TI's goal is to help enable customers to design and create their own end-product solutions that meet applicable functional safety standards and requirements. Nonetheless, such components are subject to these terms.

No TI components are authorized for use in FDA Class III (or similar life-critical medical equipment) unless authorized officers of the parties have executed a special agreement specifically governing such use.

Only those TI components which TI has specifically designated as military grade or "enhanced plastic" are designed and intended for use in military/aerospace applications or environments. Buyer acknowledges and agrees that any military or aerospace use of TI components which have **not** been so designated is solely at the Buyer's risk, and that Buyer is solely responsible for compliance with all legal and regulatory requirements in connection with such use.

TI has specifically designated certain components as meeting ISO/TS16949 requirements, mainly for automotive use. In any case of use of non-designated products, TI will not be responsible for any failure to meet ISO/TS16949.

### Products

Audio	<a href="http://www.ti.com/audio">www.ti.com/audio</a>
Amplifiers	<a href="http://amplifier.ti.com">amplifier.ti.com</a>
Data Converters	<a href="http://dataconverter.ti.com">dataconverter.ti.com</a>
DLP® Products	<a href="http://www.dlp.com">www.dlp.com</a>
DSP	<a href="http://dsp.ti.com">dsp.ti.com</a>
Clocks and Timers	<a href="http://www.ti.com/clocks">www.ti.com/clocks</a>
Interface	<a href="http://interface.ti.com">interface.ti.com</a>
Logic	<a href="http://logic.ti.com">logic.ti.com</a>
Power Mgmt	<a href="http://power.ti.com">power.ti.com</a>
Microcontrollers	<a href="http://microcontroller.ti.com">microcontroller.ti.com</a>
RFID	<a href="http://www.ti-rfid.com">www.ti-rfid.com</a>
OMAP Applications Processors	<a href="http://www.ti.com/omap">www.ti.com/omap</a>
Wireless Connectivity	<a href="http://www.ti.com/wirelessconnectivity">www.ti.com/wirelessconnectivity</a>

### Applications

Automotive and Transportation	<a href="http://www.ti.com/automotive">www.ti.com/automotive</a>
Communications and Telecom	<a href="http://www.ti.com/communications">www.ti.com/communications</a>
Computers and Peripherals	<a href="http://www.ti.com/computers">www.ti.com/computers</a>
Consumer Electronics	<a href="http://www.ti.com/consumer-apps">www.ti.com/consumer-apps</a>
Energy and Lighting	<a href="http://www.ti.com/energy">www.ti.com/energy</a>
Industrial	<a href="http://www.ti.com/industrial">www.ti.com/industrial</a>
Medical	<a href="http://www.ti.com/medical">www.ti.com/medical</a>
Security	<a href="http://www.ti.com/security">www.ti.com/security</a>
Space, Avionics and Defense	<a href="http://www.ti.com/space-avionics-defense">www.ti.com/space-avionics-defense</a>
Video and Imaging	<a href="http://www.ti.com/video">www.ti.com/video</a>

### TI E2E Community

[e2e.ti.com](http://e2e.ti.com)

## Looking for pricing, stock, or lifecycle information?

Click below to explore more details on WIN SOURCE:

 [View TPS25910RSAR](#) on WIN SOURCE

 [Texas Instruments](#) Information

## Optimize Your Supply Chain with WIN SOURCE Solutions

-  Global Sourcing Solution
-  Obsolete Management
-  Cost Control Management
-  Shortage Management
-  Alternative Solution
-  Excess Inventory Management