

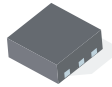

**THE DATASHEET OF  
TPS2561QDRCRQ1**





# DUAL CHANNEL PRECISION ADJUSTABLE CURRENT-LIMITED POWER SWITCH

 Check for Samples: [TPS2561-Q1](#)

## FEATURES

- Qualified for Automotive Applications
- Two Separate Current Limiting Channels
- Meets USB Current-Limiting Requirements
- Adjustable Current Limit, 250 mA–2.8 A (typ)
- $\pm 7.5\%$  Current-Limit Accuracy at 2.8 A
- Fast Overcurrent Response - 3.5- $\mu$ S (typ)
- Two 44-m $\Omega$  High-Side MOSFETs
- Operating Range: 2.5 V to 6.5 V
- 2- $\mu$ A Maximum Standby Supply Current
- Built-in Soft-Start
- 15 kV or 8 kV System-Level ESD Capable
- UL Listed – File No. E169910
- CB and Nemko Certified

## DESCRIPTION

The TPS2561-Q1 is a dual-channel power-distribution switch intended for applications where precision current limiting is required or heavy capacitive loads are encountered. These devices offer a programmable current-limit threshold between 250 mA and 2.8 A (typ) per channel through an external resistor. The power-switch rise and fall times are controlled to minimize current surges during turn on or off.

Each channel of the TPS2561-Q1 device limits the output current to a safe level by switching into a constant-current mode when the output load exceeds the current-limit threshold. The FAULTx logic output for each channel independently asserts low during overcurrent and over temperature conditions.

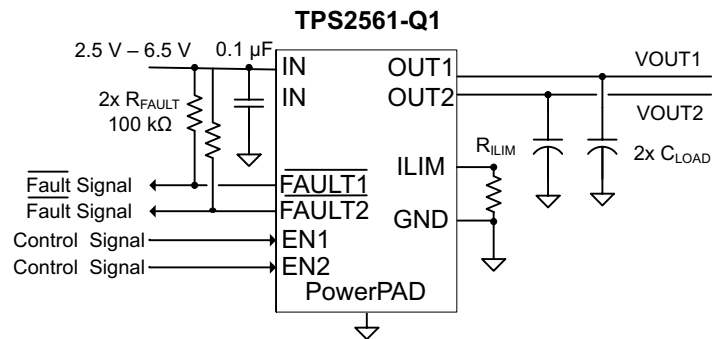
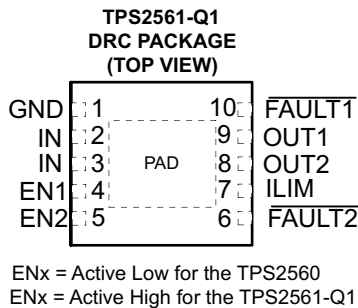

**Figure 1. Typical Application as USB Power Switch**

GENERAL SWITCH CATALOG						
33 m $\Omega$ , single	80 m $\Omega$ , single	80 m $\Omega$ , dual	80 m $\Omega$ , dual	80 m $\Omega$ , triple	80 m $\Omega$ , quad	80 m $\Omega$ , quad
TPS201xA 0.2 A - 2 A TPS202x 0.2 A - 2 A TPS203x 0.2 A - 2 A	TPS2014 600 mA TPS2015 1 A TPS2041B 500 mA TPS2051B 500 mA TPS2045A 250 mA TPS2049 100 mA TPS2055A 250 mA TPS2061 1 A TPS2065 1 A TPS2068 1.5 A TPS2069 1.5 A	TPS2042B 500 mA TPS2052B 500 mA TPS2046B 250 mA TPS2056 250 mA TPS2062 1 A TPS2066 1 A TPS2060 1.5 A TPS2064 1.5 A	TPS2080 500 mA TPS2081 500 mA TPS2082 500 mA TPS2090 250 mA TPS2091 250 mA TPS2092 250 mA	TPS2043B 500 mA TPS2053B 500 mA TPS2047B 250 mA TPS2057A 250 mA TPS2063 1 A TPS2067 1 A	TPS2044B 500 mA TPS2054B 500 mA TPS2048A 250 mA TPS2058 250 mA	TPS2085 500 mA TPS2086 500 mA TPS2087 500 mA TPS2095 250 mA TPS2096 250 mA TPS2097 250 mA



Please be aware that an important notice concerning availability, standard warranty, and use in critical applications of Texas Instruments semiconductor products and disclaimers thereto appears at the end of this data sheet.

PowerPAD is a trademark of Texas Instruments.

# TPS2561-Q1

SLVSB51A – DECEMBER 2011 – REVISED AUGUST 2012

www.ti.com



This integrated circuit can be damaged by ESD. Texas Instruments recommends that all integrated circuits be handled with appropriate precautions. Failure to observe proper handling and installation procedures can cause damage.

ESD damage can range from subtle performance degradation to complete device failure. Precision integrated circuits may be more susceptible to damage because very small parametric changes could cause the device not to meet its published specifications.

## ORDERING INFORMATION<sup>(1)</sup>

T <sub>A</sub> <sup>(2)</sup>	PACKAGE		ORDERABLE PART NUMBER	TOP-SIDE MARKING
-40°C to 125°C	SON - DRC	Reel of 3000	TPS2561QDRCRQ1	PXPQ

- (1) For the most current package and ordering information, see the Package Option Addendum at the end of this document, or see the TI website at [www.ti.com](http://www.ti.com).
- (2) Maximum ambient temperature is a function of device junction temperature and system level considerations, such as power dissipation and board layout. See *dissipation rating table* and *recommended operating conditions* for specific information related to these devices.

## ABSOLUTE MAXIMUM RATINGS

over operating free-air temperature range unless otherwise noted<sup>(1) (2)</sup>

	VALUE	UNIT
Voltage range on IN, OUTx, ENx or $\overline{\text{ENx}}$ , ILIM, $\overline{\text{FAULTx}}$	-0.3 to 7	V
Voltage range from IN to OUTx	-7 to 7	V
Continuous output current	Internally Limited	
Continuous total power dissipation	See the Dissipation Rating Table	
Continuous $\overline{\text{FAULTx}}$ sink current	25	mA
ILIM source current	Internally Limited	mA
ESD	HBM	2
	CDM	1000
ESD – system level (contact/air) <sup>(3)</sup>	8/15	kV
T <sub>J</sub> Maximum junction temperature	-40 to 125 <sup>(4)</sup>	°C

- (1) Stresses beyond those listed under *absolute maximum ratings* may cause permanent damage to the device. These are stress ratings only, and functional operation of the device at these or any other conditions beyond those indicated under *recommended operating conditions* is not implied. Exposure to absolute-maximum-rated conditions for extended periods may affect device reliability.
- (2) Voltages are referenced to GND unless otherwise noted.
- (3) Surges per EN61000-4-2, 1999 applied between USB and output ground of the TPS2561EVM (HPA424) evaluation module (documentation available on the web.) These were the test level, not the failure threshold.
- (4) Ambient over temperature shutdown threshold

## DISSIPATION RATING TABLE

BOARD	PACKAGE	THERMAL RESISTANCE <sup>(1)</sup> $\theta_{JA}$	THERMAL RESISTANCE $\theta_{JC}$	T <sub>A</sub> ≤ 25°C POWER RATING
High-K <sup>(2)</sup>	DRC	41.6°C/W	10.7°C/W	2403 mW

- (1) Mounting per the *PowerPAD™ Thermally Enhanced Package* application report (SLMA002)
- (2) The JEDEC high-K (2s2p) board used to derive this data was a 3in x 3in, multilayer board with 1-ounce internal power and ground planes and 2-ounce copper traces on top and bottom of the board.

**RECOMMENDED OPERATING CONDITIONS**

		MIN	MAX	UNIT
$V_{IN}$	Input voltage, IN	2.5	6.5	V
$V_{ENx}$	Enable voltage	0	6.5	V
$V_{/ENx}$				
$V_{IH}$	High-level input voltage on ENx or $\overline{ENx}$	1.1		V
$V_{IL}$	Low-level input voltage on ENx or $\overline{ENx}$		0.66	
$I_{OUTx}$	Continuous output current per channel, OUTx	0	2.5	A
	Continuous $\overline{FAULTx}$ sink current	0	10	mA
$T_J$	Operating virtual junction temperature	-40	125	°C
$R_{ILIM}$	Recommended resistor limit range	20	187	kΩ

**ELECTRICAL CHARACTERISTICS**

over recommended operating conditions,  $V_{/ENx} = 0$  V, or  $V_{ENx} = V_{IN}$  (unless otherwise noted)

PARAMETER	TEST CONDITIONS <sup>(1)</sup>	MIN	TYP	MAX	UNIT	
<b>POWER SWITCH</b>						
$r_{DS(on)}$	Static drain-source on-state resistance per channel, IN to OUTx <sup>(2)</sup>	$T_J = 25$ °C		44	50	mΩ
		$-40$ °C $\leq T_J \leq 125$ °C			79	
$t_r$	Rise time, output <sup>(2)</sup>	$V_{IN} = 6.5$ V	2	3	4	ms
		$V_{IN} = 2.5$ V	1	2	3	
$t_f$	Fall time, output <sup>(2)</sup>	$V_{IN} = 6.5$ V	0.6	0.8	1	
		$V_{IN} = 2.5$ V	0.4	0.6	0.8	
<b>ENABLE INPUT EN OR <math>\overline{EN}</math></b>						
	Enable pin turn on/off threshold	0.66		1.1	V	
	Hysteresis		55 <sup>(3)</sup>		mV	
$I_{EN}$	Input current	$V_{ENx} = 0$ V or 6.5 V, $V_{/ENx} = 0$ V or 6.5 V		-0.5	0.5	μA
$t_{on}$	Turn-on time <sup>(2)</sup>	$C_{Lx} = 1$ μF, $R_{Lx} = 100$ Ω, (see Figure 2)			9	ms
$t_{off}$	Turn-off time <sup>(2)</sup>				6	ms
<b>CURRENT LIMIT</b>						
$I_{OS}$	Current-limit threshold per channel (Maximum DC output current $I_{OUTx}$ delivered to load) and Short-circuit current, OUTx connected to GND	$R_{ILIM} = 20$ kΩ	2590	2800	3005	mA
		$R_{ILIM} = 61.9$ kΩ	800	900	1005	
		$R_{ILIM} = 100$ kΩ	470	560	645	
$t_{IOS}$	Response time to short circuit	$V_{IN} = 5.0$ V (see Figure 3)		3.5 <sup>(3)</sup>		μs

- (1) Pulse-testing techniques maintain junction temperature close to ambient temperature; thermal effects must be taken into account separately.
- (2) Not production tested.
- (3) These parameters are provided for reference only, and do not constitute part of TI's published specifications for purposes of TI's product warranty.

# TPS2561-Q1

SLVSB51A – DECEMBER 2011 – REVISED AUGUST 2012

www.ti.com

## ELECTRICAL CHARACTERISTICS (continued)

over recommended operating conditions,  $V_{/ENx} = 0\text{ V}$ , or  $V_{ENx} = V_{IN}$  (unless otherwise noted)

PARAMETER		TEST CONDITIONS <sup>(1)</sup>	MIN	TYP	MAX	UNIT
<b>SUPPLY CURRENT</b>						
$I_{IN\_off}$	Supply current, low-level output	$V_{IN} = 6.5\text{ V}$ , No load on $OUTx$ , $V_{/ENx} = 6.5\text{ V}$ or $V_{ENx} = 0\text{ V}$		0.1	2	$\mu\text{A}$
$I_{IN\_on}$	Supply current, high-level output	$V_{IN} = 6.5\text{ V}$ , No load on $OUT$		100	125	$\mu\text{A}$
				85	110	$\mu\text{A}$
$I_{REV}$	Reverse leakage current	$V_{OUTx} = 6.5\text{ V}$ , $V_{IN} = 0\text{ V}$		0.01	1	$\mu\text{A}$
<b>UNDERVOLTAGE LOCKOUT</b>						
UVLO	Low-level input voltage, $IN$	$V_{IN}$ rising, $T_J = 25^\circ\text{C}$		2.35	2.45	V
	Hysteresis, $IN$	$T_J = 25^\circ\text{C}$		35		mV
<b>FAULTx FLAG</b>						
$V_{OL}$	Output low voltage, $\overline{FAULTx}$	$I_{\overline{FAULTx}} = 1\text{ mA}$ , $\overline{FAULTx}$ assertion or de-assertion due to overcurrent condition			180	mV
	Off-state leakage	$V_{\overline{FAULTx}} = 6.5\text{ V}$			1	$\mu\text{A}$
	$\overline{FAULTx}$ deglitch	$I_{\overline{FAULTx}} = 1\text{ mA}$ , $\overline{FAULTx}$ assertion or de-assertion due to overcurrent condition	6	9	13	ms
<b>THERMAL SHUTDOWN</b>						
OTSD2	Thermal shutdown threshold <sup>(4)</sup>		155			$^\circ\text{C}$
OTSD	Thermal shutdown threshold in current-limit <sup>(4)</sup>		135			$^\circ\text{C}$
	Hysteresis			20 <sup>(5)</sup>		$^\circ\text{C}$

(4) Not production tested.

(5) These parameters are provided for reference only, and do not constitute part of TI's published specifications for purposes of TI's product warranty.

## DEVICE INFORMATION

### Pin Functions

PIN		I/O	DESCRIPTION
NAME	NO.		
$\overline{\text{EN1}}$	-	I	Enable input, logic low turns on channel one power switch
EN1	4	I	Enable input, logic high turns on channel one power switch
$\overline{\text{EN2}}$	-	I	Enable input, logic low turns on channel two power switch
EN2	5	I	Enable input, logic high turns on channel two power switch
GND	1		Ground connection; connect externally to PowerPAD
IN	2, 3	I	Input voltage; connect a 0.1 $\mu\text{F}$ or greater ceramic capacitor from IN to GND as close to the IC as possible.
$\overline{\text{FAULT1}}$	10	O	Active-low open-drain output, asserted during overcurrent or overtemperature condition on channel one.
$\overline{\text{FAULT2}}$	6	O	Active-low open-drain output, asserted during overcurrent or overtemperature condition on channel two
OUT1	9	O	Power-switch output for channel one
OUT2	8	O	Power-switch output for channel two
ILIM	7	O	External resistor used to set current-limit threshold; recommended $20 \text{ k}\Omega \leq R_{\text{ILIM}} \leq 187 \text{ k}\Omega$ .
PowerPAD™	PAD		Internally connected to GND; used to heat-sink the part to the circuit board traces. Connect PowerPAD to GND pin externally.

### FUNCTIONAL BLOCK DIAGRAM

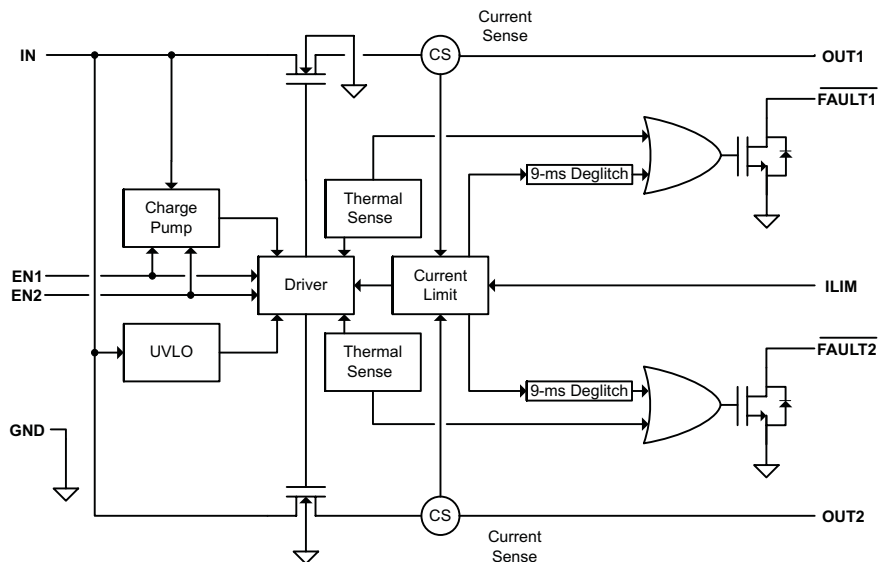

PARAMETER MEASUREMENT INFORMATION

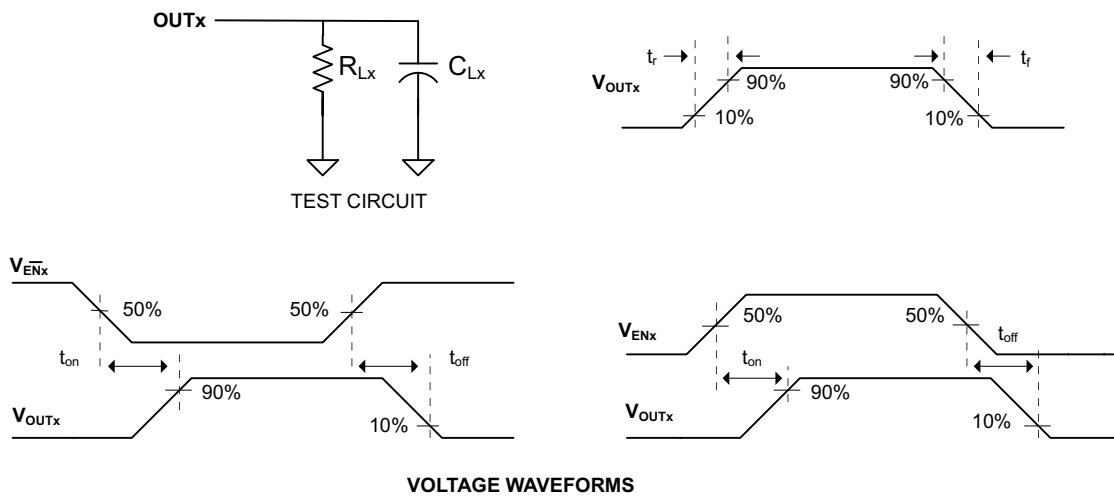

Figure 2. Test Circuit and Voltage Waveforms

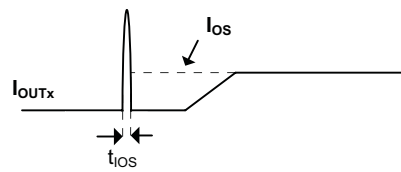

Figure 3. Response Time to Short Circuit Waveform

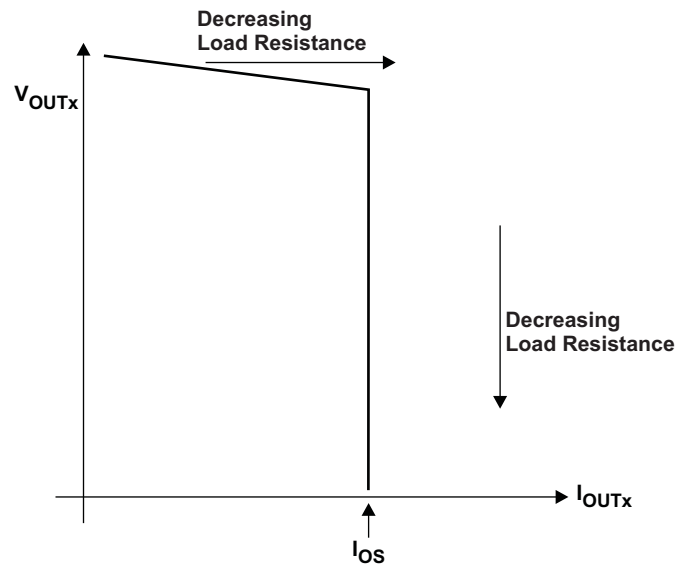

Figure 4. Output Voltage vs. Current-Limit Threshold

TYPICAL CHARACTERISTICS

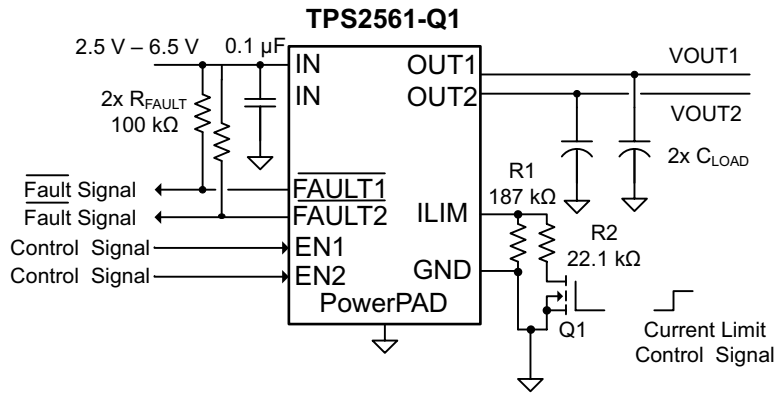

Figure 5. Typical Characteristics Reference Schematic

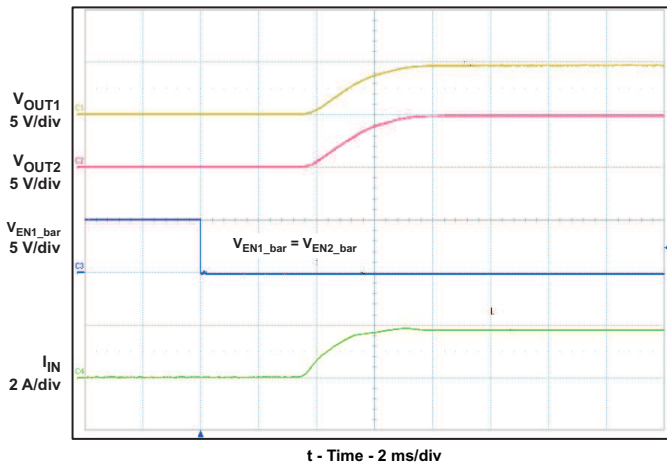

Figure 6. Turn-on Delay and Rise Time

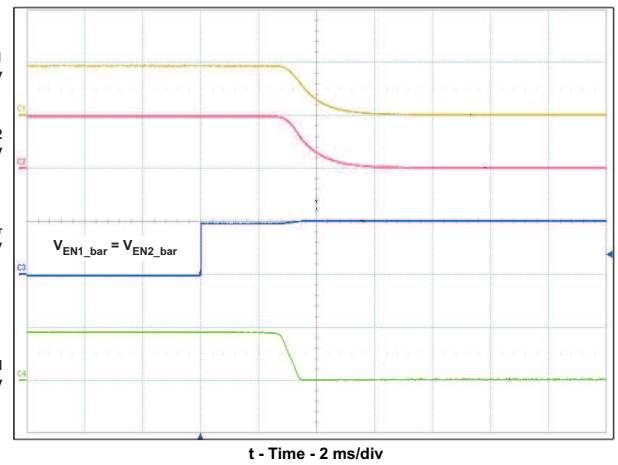

Figure 7. Turn-off Delay and Fall Time

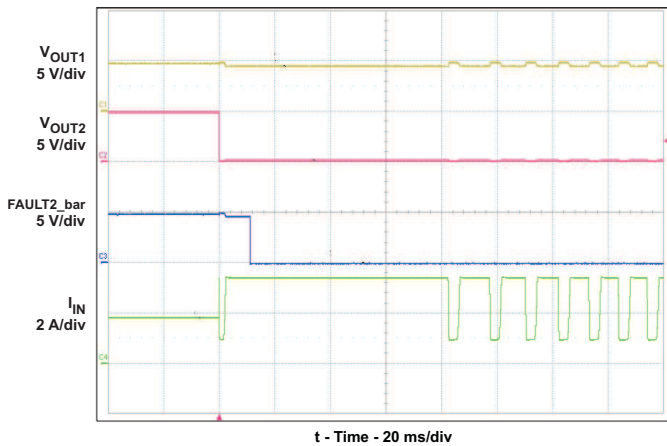

Figure 8. Full-Load to Short-Circuit Transient Response

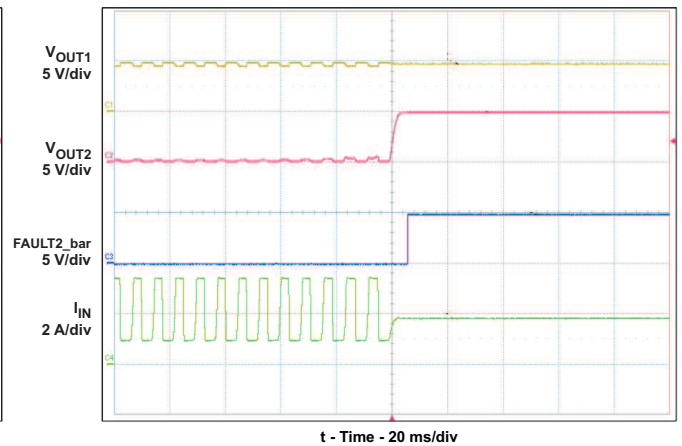

Figure 9. Short-Circuit to Full-Load Recovery Response

TYPICAL CHARACTERISTICS (continued)

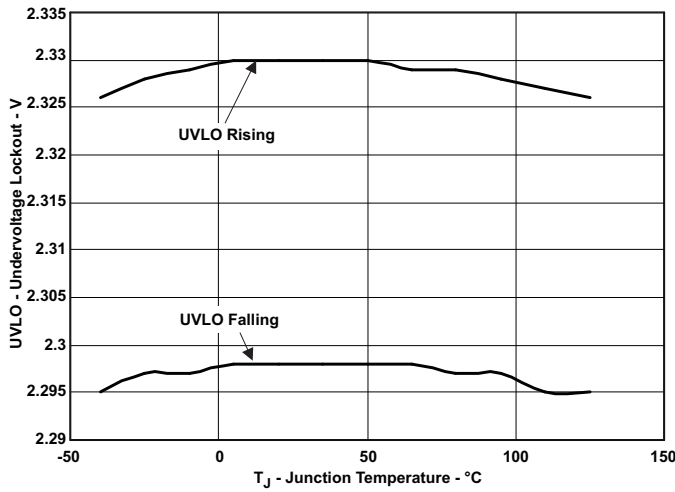

Figure 10. UVLO – Undervoltage Lockout – V

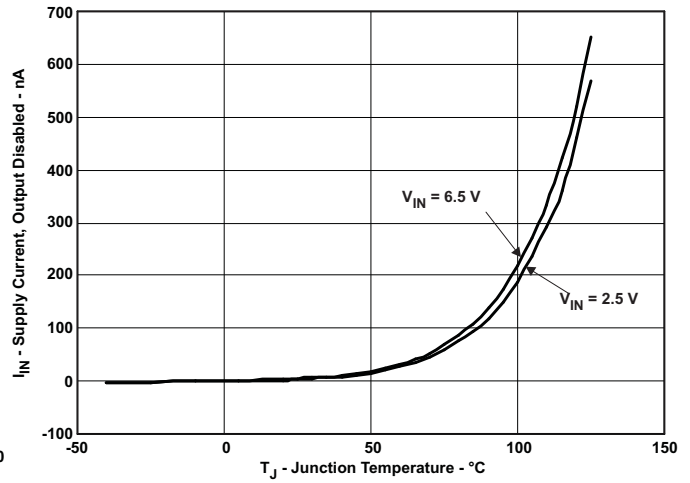

Figure 11.  $I_{IN}$  – Supply Current, Output Disabled – nA

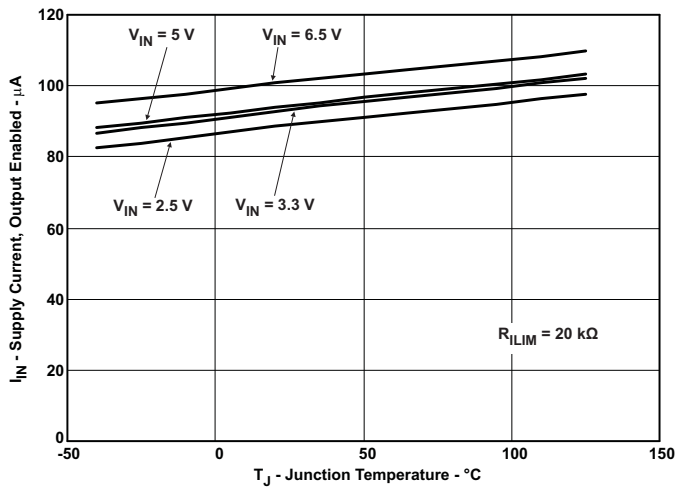

Figure 12.  $I_{IN}$  – Supply Current, Output Enabled –  $\mu$ A

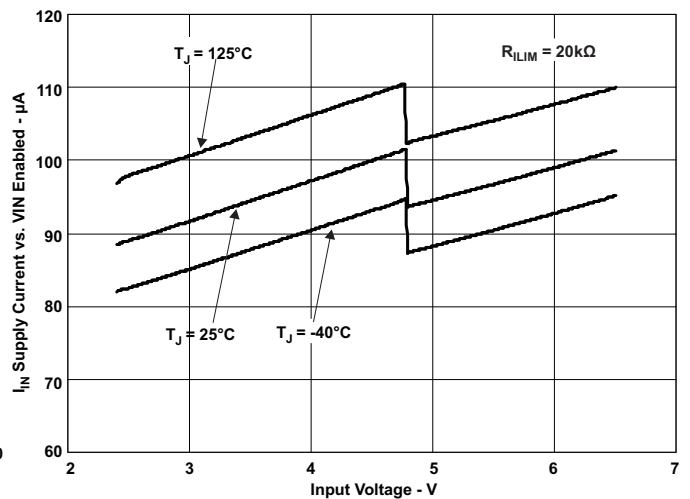

Figure 13.  $I_{IN}$  – Supply Current, Output Enabled –  $\mu$ A

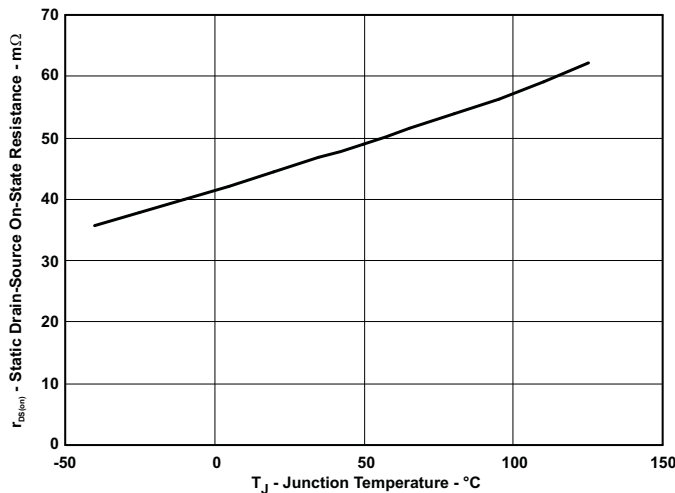

Figure 14. MOSFET  $r_{DS(on)}$  vs. Junction Temperature

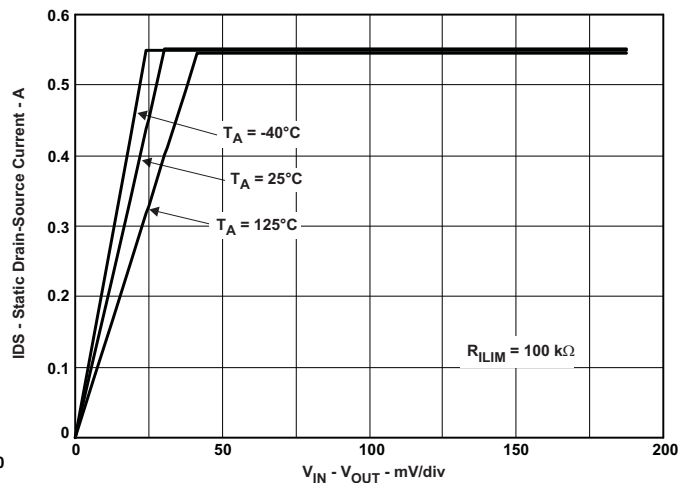

Figure 15. Switch Current vs. Drain-Source Voltage Across Switch

TYPICAL CHARACTERISTICS (continued)

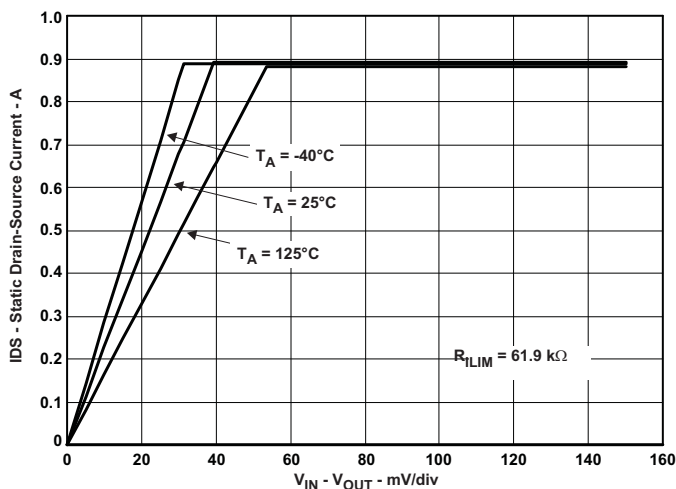

Figure 16. Switch Current vs. Drain-Source Voltage Across Switch

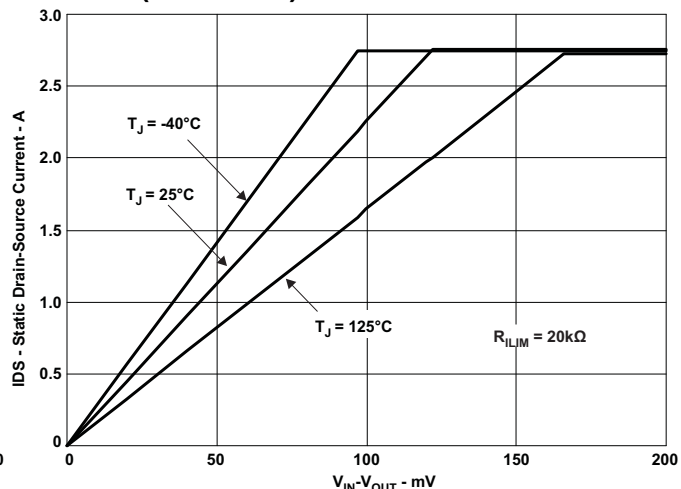

Figure 17. Switch Current vs. Drain-Source Voltage Across Switch

## DETAILED DESCRIPTION

### OVERVIEW

The TPS2561-Q1 is a dual-channel, current-limited power-distribution switch using N-channel MOSFETs for applications where short circuits or heavy capacitive loads are encountered. This device allows the user to program the current-limit threshold between 250 mA and 2.8 A (typ) per channel through an external resistor. This device incorporates an internal charge pump and gate drive circuitry necessary to drive the N-channel MOSFETs. The charge pump supplies power to the driver circuit for each channel and provides the necessary voltage to pull the gate of the MOSFET above the source. The charge pump operates from input voltages as low as 2.5 V and requires little supply current. The driver controls the gate voltage of the power switch. The driver incorporates circuitry that controls the rise and fall times of the output voltage to limit large current and voltage surges and provides built-in soft-start functionality. Each channel of the TPS2561-Q1 limits the output current to the programmed current-limit threshold  $I_{OS}$  during an overcurrent or short-circuit event by reducing the charge pump voltage driving the N-channel MOSFET and operating it in the linear range of operation. The result of limiting the output current to  $I_{OS}$  reduces the output voltage at OUTx because the N-channel MOSFET is no longer fully enhanced.

### OVERCURRENT CONDITIONS

The TPS2561-Q1 responds to overcurrent conditions by limiting the output current per channel to  $I_{OS}$ . When an overcurrent condition is detected, the device maintains a constant output current and reduces the output voltage accordingly. Two possible overload conditions can occur.

The first condition is when a short circuit or partial short circuit is present when the device is powered-up or enabled. The output voltage is held near zero potential with respect to ground and the TPS2561-Q1 ramps the output current to  $I_{OS}$ . The TPS2561-Q1 devices will limit the current to  $I_{OS}$  until the overload condition is removed or the device begins to thermal cycle.

The second condition is when a short circuit, partial short circuit, or transient overload occurs while the device is enabled and powered on. The device responds to the overcurrent condition within time  $t_{IOS}$  (see [Figure 3](#)). The current-sense amplifier is overdriven during this time and momentarily disables the internal current-limit MOSFET. The current-sense amplifier recovers and ramps the output current to  $I_{OS}$ . Similar to the previous case, the TPS2561-Q1 device limits the current to  $I_{OS}$  until the overload condition is removed or the device begins to thermal cycle.

The TPS2561-Q1 thermal cycles if an overload condition is present long enough to activate thermal limiting in any of the above cases. The device turns off when the junction temperature exceeds 135°C (min) while in current limit. The device remains off until the junction temperature cools 20°C (typ) and then restarts. The TPS2561-Q1 cycles on and off until the overload is removed (see [Figure 9](#)).

## FAULTx RESPONSE

The  $\overline{\text{FAULTx}}$  open-drain outputs are asserted (active low) on an individual channel during an overcurrent or overtemperature condition. The TPS2561-Q1 asserts the  $\overline{\text{FAULTx}}$  signal until the fault condition is removed and the device resumes normal operation on that channel. The TPS2561-Q1 is designed to eliminate false  $\overline{\text{FAULTx}}$  reporting by using an internal delay deglitch circuit (9-ms typ) for overcurrent conditions without the need for external circuitry. This ensures that  $\overline{\text{FAULTx}}$  is not accidentally asserted due to normal operation such as starting into a heavy capacitive load. The deglitch circuitry delays entering and leaving current-limited induced fault conditions. The  $\overline{\text{FAULTx}}$  signal is not deglitched when the MOSFET is disabled due to an overtemperature condition but is deglitched after the device has cooled and begins to turn on. This unidirectional deglitch prevents  $\overline{\text{FAULTx}}$  oscillation during an overtemperature event.

## UNDERVOLTAGE LOCKOUT (UVLO)

The undervoltage lockout (UVLO) circuit disables the power switch until the input voltage reaches the UVLO turn-on threshold. Built-in hysteresis prevents unwanted on and off cycling due to input voltage droop during turn on.

## ENABLE ( $\overline{\text{ENx}}$ OR $\text{ENx}$ )

The logic enables control the power switches and device supply current. The supply current is reduced to less than 2- $\mu\text{A}$  when a logic high is present on  $\text{ENx}$  or when a logic low is present on  $\overline{\text{ENx}}$ . A logic low input on  $\overline{\text{ENx}}$  or a logic high input on  $\text{ENx}$  enables the driver, control circuits, and power switches. The enable inputs are compatible with both TTL and CMOS logic levels.

## THERMAL SENSE

The TPS2561-Q1 self protects by using two independent thermal sensing circuits that monitor the operating temperature of the power switch and disable operation if the temperature exceeds recommended operating conditions. Each channel of the TPS2561-Q1 operates in constant-current mode during an overcurrent condition, which increases the voltage drop across the power switch. The power dissipation in the package is proportional to the voltage drop across the power switch, which increases the junction temperature during an overcurrent condition. The first thermal sensor (OTSD) turns off the individual power switch channel when the die temperature exceeds 135°C (min) and the channel is in current limit. Hysteresis is built into the thermal sensor, and the switch turns on after the device has cooled approximately 20°C.

The TPS2561-Q1 also has a second ambient thermal sensor (OTSD2). The ambient thermal sensor turns off both power switch channels when the die temperature exceeds 155°C (min) regardless of whether the power switch channels are in current limit and will turn on the power switches after the device has cooled approximately 20°C. The TPS2561-Q1 continues to cycle off and on until the fault is removed.

## APPLICATION INFORMATION

### INPUT AND OUTPUT CAPACITANCE

Input and output capacitance improves the performance of the device; the actual capacitance should be optimized for the particular application. For all applications, a 0.1- $\mu$ F or greater ceramic bypass capacitor between IN and GND is recommended as close to the device as possible for local noise decoupling. This precaution reduces ringing on the input due to power-supply transients. Additional input capacitance may be needed on the input to reduce voltage overshoot from exceeding the absolute maximum voltage of the device during heavy transient conditions. This is especially important during bench testing when long, inductive cables are used to connect the evaluation board to the bench power supply.

Output capacitance is not required, but placing a high-value electrolytic capacitor on the output pin is recommended when large transient currents are expected on the output.

### PROGRAMMING THE CURRENT-LIMIT THRESHOLD

The overcurrent threshold is user programmable through an external resistor,  $R_{ILIM}$ .  $R_{ILIM}$  sets the current-limit threshold for both channels. The TPS2561-Q1 use an internal regulation loop to provide a regulated voltage on the ILIM pin. The current-limit threshold is proportional to the current sourced out of ILIM. The recommended 1% resistor range for  $R_{ILIM}$  is  $20\text{ k}\Omega \leq R_{ILIM} \leq 187\text{ k}\Omega$  to ensure stability of the internal regulation loop. Many applications require that the minimum current limit is above a certain current level or that the maximum current limit is below a certain current level, so it is important to consider the tolerance of the overcurrent threshold when selecting a value for  $R_{ILIM}$ . The following equations calculate the resulting overcurrent threshold for a given external resistor value ( $R_{ILIM}$ ). The traces routing the  $R_{ILIM}$  resistor to the TPS2561-Q1 should be as short as possible to reduce parasitic effects on the current-limit accuracy.

$$I_{OSmax} \text{ (mA)} = \frac{52850 \text{ V}}{R_{ILIM}^{0.957} \text{ k}\Omega}$$

$$I_{OSnom} \text{ (mA)} = \frac{56000 \text{ V}}{R_{ILIM} \text{ k}\Omega}$$

$$I_{OSmin} \text{ (mA)} = \frac{61200 \text{ V}}{R_{ILIM}^{1.056} \text{ k}\Omega}$$

(1)

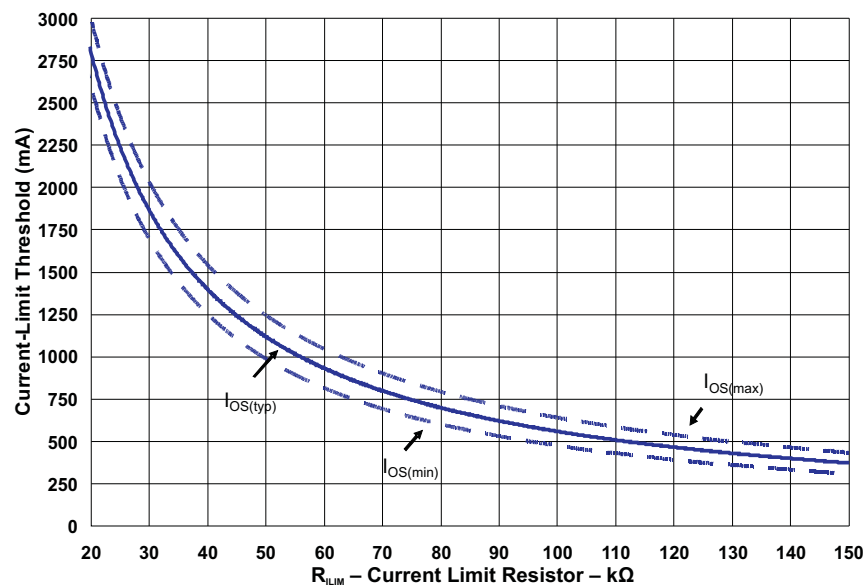

Figure 18. Current-Limit Threshold vs.  $R_{ILIM}$

### APPLICATION 1: DESIGNING ABOVE A MINIMUM CURRENT LIMIT

Some applications require that current limiting cannot occur below a certain threshold. For this example, assume that 2 A must be delivered to the load so that the minimum desired current-limit threshold is 2000 mA. Use the  $I_{OS}$  equations and [Figure 18](#) to select  $R_{ILIM}$ .

$$I_{OSmin} \text{ (mA)} = 2000 \text{ mA}$$

$$I_{OSmin} \text{ (mA)} = \frac{61200 \text{ V}}{R_{ILIM}^{1.056} \text{ k}\Omega}$$

$$R_{ILIM} \text{ (k}\Omega) = \left( \frac{61200 \text{ V}}{I_{OSmin} \text{ mA}} \right)^{\frac{1}{1.056}}$$

$$R_{ILIM} \text{ (k}\Omega) = 25.52 \text{ k}\Omega \tag{2}$$

Select the closest 1% resistor less than the calculated value:  $R_{ILIM} = 25.5 \text{ k}\Omega$ . This sets the minimum current-limit threshold at 2 A. Use the  $I_{OS}$  equations, [Figure 18](#), and the previously calculated value for  $R_{ILIM}$  to calculate the maximum resulting current-limit threshold.

$$R_{ILIM} \text{ (k}\Omega) = 25.52 \text{ k}\Omega$$

$$I_{OSmax} \text{ (mA)} = \frac{52850 \text{ V}}{R_{ILIM}^{0.957} \text{ k}\Omega}$$

$$I_{OSmax} \text{ (mA)} = \frac{52850 \text{ V}}{25.5^{0.957} \text{ k}\Omega}$$

$$I_{OSmax} \text{ (mA)} = 2382 \text{ mA} \tag{3}$$

The resulting maximum current-limit threshold is 2382 mA with a 25.5-k $\Omega$  resistor.

### APPLICATION 2: DESIGNING BELOW A MAXIMUM CURRENT LIMIT

Some applications require that current limiting must occur below a certain threshold. For this example, assume that the desired upper current-limit threshold must be below 1000 mA to protect an up-stream power supply. Use the  $I_{OS}$  equations and [Figure 18](#) to select  $R_{ILIM}$ .

$$I_{OSmax} \text{ (mA)} = 1000 \text{ mA}$$

$$I_{OSmax} \text{ (mA)} = \frac{52850 \text{ V}}{R_{ILIM}^{0.957} \text{ k}\Omega}$$

$$R_{ILIM} \text{ (k}\Omega) = \left( \frac{52850 \text{ V}}{I_{OSmax} \text{ mA}} \right)^{\frac{1}{0.957}}$$

$$R_{ILIM} \text{ (k}\Omega) = 63.16 \text{ k}\Omega \tag{4}$$

Select the closest 1% resistor greater than the calculated value:  $R_{ILIM} = 63.4 \text{ k}\Omega$ . This sets the maximum current-limit threshold at 1000 mA. Use the  $I_{OS}$  equations, [Figure 18](#), and the previously calculated value for  $R_{ILIM}$  to calculate the minimum resulting current-limit threshold.

$$R_{ILIM} \text{ (k}\Omega) = 63.4 \text{ k}\Omega$$

$$I_{OSmin} \text{ (mA)} = \frac{61200 \text{ V}}{R_{ILIM}^{1.056} \text{ k}\Omega}$$

$$I_{OSmin} \text{ (mA)} = \frac{61200 \text{ V}}{63.4^{1.056} \text{ k}\Omega}$$

$$I_{OSmin} \text{ (mA)} = 765 \text{ mA} \tag{5}$$

The resulting minimum current-limit threshold is 765 mA with a 63.4-k $\Omega$  resistor.

## ACCOUNTING FOR RESISTOR TOLERANCE

The previous sections described the selection of  $R_{ILIM}$  given certain application requirements and the importance of understanding the current-limit threshold tolerance. The analysis focused only on the TPS2561-Q1 performance and assumed an exact resistor value. However, resistors sold in quantity are not exact and are bounded by an upper and lower tolerance centered around a nominal resistance. The additional  $R_{ILIM}$  resistance tolerance directly affects the current-limit threshold accuracy at a system level. The following table shows a process that accounts for worst-case resistor tolerance assuming 1% resistor values. Step one follows the selection process outlined in the application examples above. Step two determines the upper and lower resistance bounds of the selected resistor. Step three uses the upper and lower resistor bounds in the  $I_{OS}$  equations to calculate the threshold limits. It is important to use tighter tolerance resistors, for example, 0.5% or 0.1%, when precision current limiting is desired.

**Table 1. Common  $R_{ILIM}$  Resistor Selections**

Desired Nominal Current Limit (mA)	Ideal Resistor (k $\Omega$ )	Closest 1% Resistor (k $\Omega$ )	Resistor Tolerance		Actual Limits		
			1% low (k $\Omega$ )	1% high (k $\Omega$ )	IOS MIN (mA)	IOS Nom (mA)	IOS MAX (mA)
300	186.7	187	185.1	188.9	241.6	299.5	357.3
400	140	140	138.6	141.4	328	400	471.4
600	93.3	93.1	92.2	94	504.6	601.5	696.5
800	70	69.8	69.1	70.5	684	802.3	917.6
1000	56	56.2	55.6	56.8	859.9	996.4	1129.1
1200	46.7	46.4	45.9	46.9	1052.8	1206.9	1356.3
1400	40	40.2	39.8	40.6	1225	1393	1555.9
1600	35	34.8	34.5	35.1	1426.5	1609.2	1786.2
1800	31.1	30.9	30.6	31.2	1617.3	1812.3	2001.4
2000	28	28	27.7	28.3	1794.7	2000	2199.3
2200	25.5	25.5	25.2	25.8	1981	2196.1	2405.3
2400	23.3	23.2	23	23.4	2188.9	2413.8	2633
2600	21.5	21.5	21.3	21.7	2372.1	2604.7	2831.9
2800	20	20	19.8	20.2	2560.4	2800	3034.8

## POWER DISSIPATION AND JUNCTION TEMPERATURE

The low on-resistance of the N-channel MOSFET allows small surface-mount packages to pass large currents. It is good design practice to estimate power dissipation and junction temperature. The below analysis gives an approximation for calculating junction temperature based on the power dissipation in the package. However, it is important to note that thermal analysis is strongly dependent on additional system level factors. Such factors include air flow, board layout, copper thickness and surface area, and proximity to other devices dissipating power. Good thermal design practice must include all system level factors in addition to individual component analysis.

Begin by determining the  $r_{DS(on)}$  of the N-channel MOSFET relative to the input voltage and operating temperature. As an initial estimate, use the highest operating ambient temperature of interest and read  $r_{DS(on)}$  from the typical characteristics graph. Using this value, the power dissipation can be calculated by:

$$P_D = (R_{DS(on)} \times I_{OUT1}^2) + (R_{DS(on)} \times I_{OUT2}^2)$$

Where:

$P_D$  = Total power dissipation (W)

$r_{DS(on)}$  = Power switch on-resistance of one channel ( $\Omega$ )

$I_{OUTx}$  = Maximum current-limit threshold set by  $R_{ILIM}(A)$

This step calculates the total power dissipation of the N-channel MOSFET.

Finally, calculate the junction temperature:

$$T_J = P_D \times \theta_{JA} + T_A$$

Where:

$T_A$  = Ambient temperature ( $^{\circ}C$ )

$\theta_{JA}$  = Thermal resistance ( $^{\circ}C/W$ )

$P_D$  = Total power dissipation (W)

Compare the calculated junction temperature with the initial estimate. If they are not within a few degrees, repeat the calculation using the refined  $r_{DS(on)}$  from the previous calculation as the new estimate. Two or three iterations are generally sufficient to achieve the desired result. The final junction temperature is highly dependent on thermal resistance  $\theta_{JA}$ , and thermal resistance is highly dependent on the individual package and board layout. The [Dissipating Rating Table](#) provides example thermal resistances for specific packages and board layouts.

## AUTO-RETRY FUNCTIONALITY

Some applications require that an overcurrent condition disables the part momentarily during a fault condition and re-enables after a pre-set time. This auto-retry functionality can be implemented with an external resistor and capacitor. During a fault condition,  $\overline{\text{FAULT}}_x$  pulls  $\text{EN}_x$  low disabling the part. The part is disabled when  $\text{EN}_x$  is pulled below the turn-off threshold, and  $\overline{\text{FAULT}}_x$  goes high impedance allowing  $C_{\text{RETRY}}$  to begin charging. The part re-enables when the voltage on  $\text{EN}_x$  reaches the turn-on threshold, and the auto-retry time is determined by the resistor/capacitor time constant. The part will continue to cycle in this manner until the fault condition is removed.

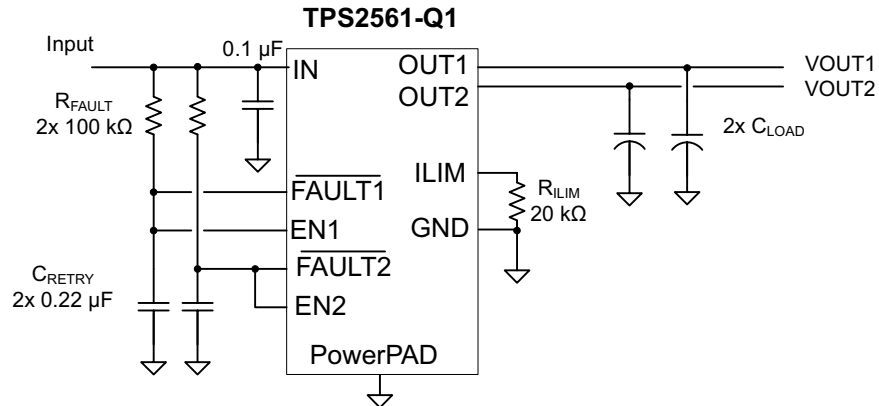

**Figure 19. Auto-Retry Functionality**

Some applications require auto-retry functionality and the ability to enable or disable with an external logic signal. The figure below shows how an external logic signal can drive  $\text{EN}$  through  $R_{\text{FAULT}}$  and maintain auto-retry functionality. The resistor/capacitor time constant determines the auto-retry time-out period.

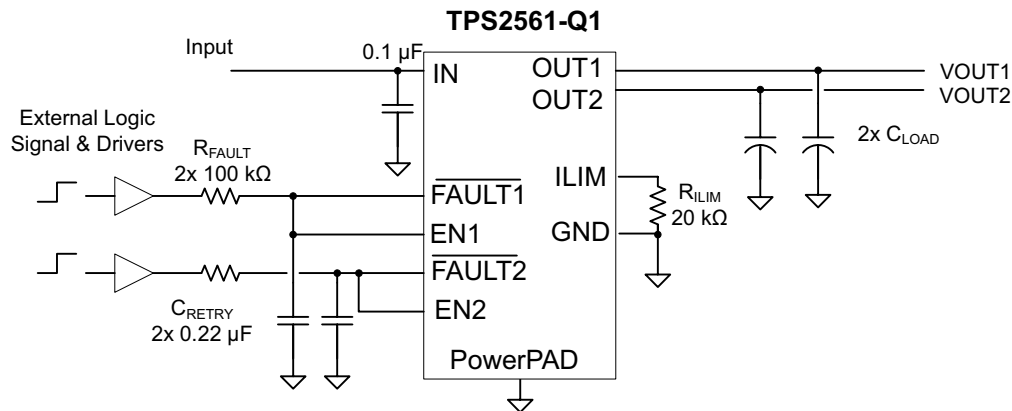

**Figure 20. Auto-Retry Functionality With External EN Signal**

## TWO-LEVEL CURRENT-LIMIT CIRCUIT

Some applications require different current-limit thresholds depending on external system conditions. Figure 21 shows an implementation for an externally controlled, two-level current-limit circuit. The current-limit threshold is set by the total resistance from ILIM to GND (see previously discussed *Programming the Current-Limit Threshold* section). A logic-level input enables or disables MOSFET Q1 and changes the current-limit threshold by modifying the total resistance from ILIM to GND. Additional MOSFET and resistor combinations can be used in parallel to Q1 and R2 to increase the number of additional current-limit levels.

### NOTE

ILIM should never be driven directly with an external signal.

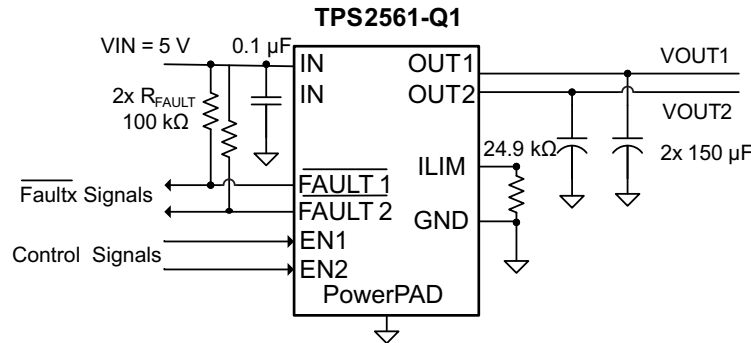

Figure 21. Two-Level Current-Limit Circuit

**REVISION HISTORY**

<b>Changes from Original (December 2011) to Revision A</b>	<b>Page</b>
• Changed the revision to A, August 2012 and aligned FEATURES and DESCRIPTION to top aligned .....	1
• Changed part number from TPS2561 to TPS2561-Q1 in all images where part number appears. ....	2
• Changed the First 2 rows of TYP and MAX columns of the ELEC CHAR table from 110 / 290 to 44 / 50, second row 320 / 79 and added cross reference to second column 'Not production tested.' .....	3

**PACKAGING INFORMATION**

Orderable Device	Status (1)	Package Type	Package Drawing	Pins	Package Qty	Eco Plan (2)	Lead finish/ Ball material (6)	MSL Peak Temp (3)	Op Temp (°C)	Device Marking (4/5)	Samples
TPS2561QDRCRQ1	ACTIVE	VSON	DRC	10	3000	RoHS & Green	NIPDAU	Level-3-260C-168 HR	-40 to 125	PXPQ	Samples

(1) The marketing status values are defined as follows:

**ACTIVE:** Product device recommended for new designs.

**LIFEBUY:** TI has announced that the device will be discontinued, and a lifetime-buy period is in effect.

**NRND:** Not recommended for new designs. Device is in production to support existing customers, but TI does not recommend using this part in a new design.

**PREVIEW:** Device has been announced but is not in production. Samples may or may not be available.

**OBSOLETE:** TI has discontinued the production of the device.

(2) **RoHS:** TI defines "RoHS" to mean semiconductor products that are compliant with the current EU RoHS requirements for all 10 RoHS substances, including the requirement that RoHS substance do not exceed 0.1% by weight in homogeneous materials. Where designed to be soldered at high temperatures, "RoHS" products are suitable for use in specified lead-free processes. TI may reference these types of products as "Pb-Free".

**RoHS Exempt:** TI defines "RoHS Exempt" to mean products that contain lead but are compliant with EU RoHS pursuant to a specific EU RoHS exemption.

**Green:** TI defines "Green" to mean the content of Chlorine (Cl) and Bromine (Br) based flame retardants meet JS709B low halogen requirements of <=1000ppm threshold. Antimony trioxide based flame retardants must also meet the <=1000ppm threshold requirement.

(3) MSL, Peak Temp. - The Moisture Sensitivity Level rating according to the JEDEC industry standard classifications, and peak solder temperature.

(4) There may be additional marking, which relates to the logo, the lot trace code information, or the environmental category on the device.

(5) Multiple Device Markings will be inside parentheses. Only one Device Marking contained in parentheses and separated by a "-" will appear on a device. If a line is indented then it is a continuation of the previous line and the two combined represent the entire Device Marking for that device.

(6) Lead finish/Ball material - Orderable Devices may have multiple material finish options. Finish options are separated by a vertical ruled line. Lead finish/Ball material values may wrap to two lines if the finish value exceeds the maximum column width.

**Important Information and Disclaimer:**The information provided on this page represents TI's knowledge and belief as of the date that it is provided. TI bases its knowledge and belief on information provided by third parties, and makes no representation or warranty as to the accuracy of such information. Efforts are underway to better integrate information from third parties. TI has taken and continues to take reasonable steps to provide representative and accurate information but may not have conducted destructive testing or chemical analysis on incoming materials and chemicals. TI and TI suppliers consider certain information to be proprietary, and thus CAS numbers and other limited information may not be available for release.

In no event shall TI's liability arising out of such information exceed the total purchase price of the TI part(s) at issue in this document sold by TI to Customer on an annual basis.

**OTHER QUALIFIED VERSIONS OF TPS2561-Q1 :**

- Catalog: [TPS2561](#)

NOTE: Qualified Version Definitions:

- Catalog - TI's standard catalog product

**TAPE AND REEL INFORMATION**

**QUADRANT ASSIGNMENTS FOR PIN 1 ORIENTATION IN TAPE**

\*All dimensions are nominal

Device	Package Type	Package Drawing	Pins	SPQ	Reel Diameter (mm)	Reel Width W1 (mm)	A0 (mm)	B0 (mm)	K0 (mm)	P1 (mm)	W (mm)	Pin1 Quadrant
TPS2561QDRCRQ1	VSON	DRC	10	3000	330.0	12.4	3.3	3.3	1.1	8.0	12.0	Q2

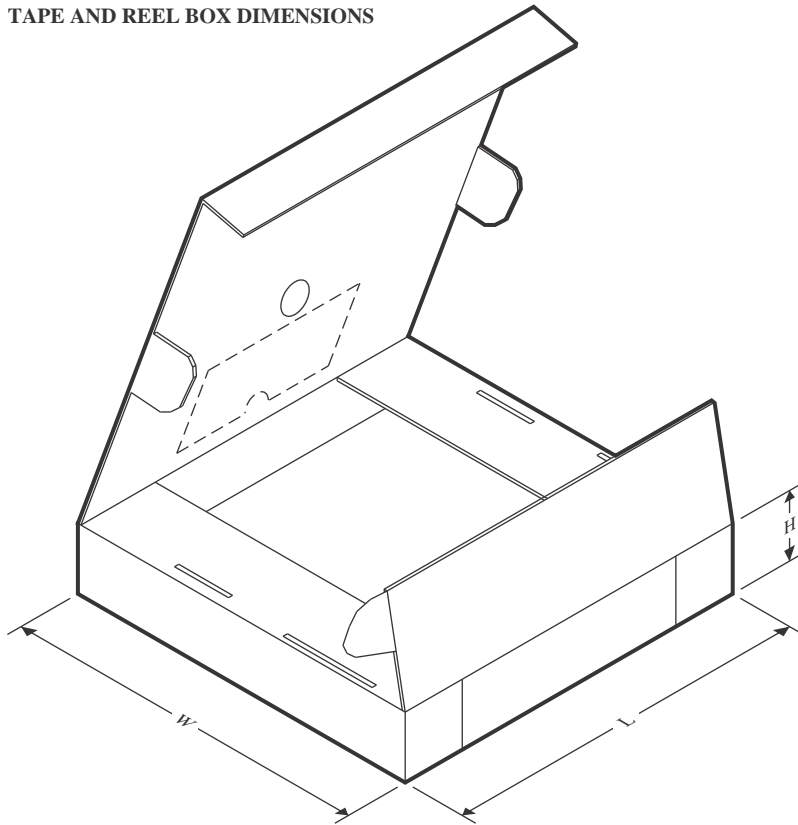
**TAPE AND REEL BOX DIMENSIONS**

\*All dimensions are nominal

Device	Package Type	Package Drawing	Pins	SPQ	Length (mm)	Width (mm)	Height (mm)
TPS2561QDRCRQ1	VSON	DRC	10	3000	356.0	356.0	35.0

## GENERIC PACKAGE VIEW

**DRC 10**

**VSON - 1 mm max height**

3 x 3, 0.5 mm pitch

PLASTIC SMALL OUTLINE - NO LEAD

This image is a representation of the package family, actual package may vary.  
Refer to the product data sheet for package details.

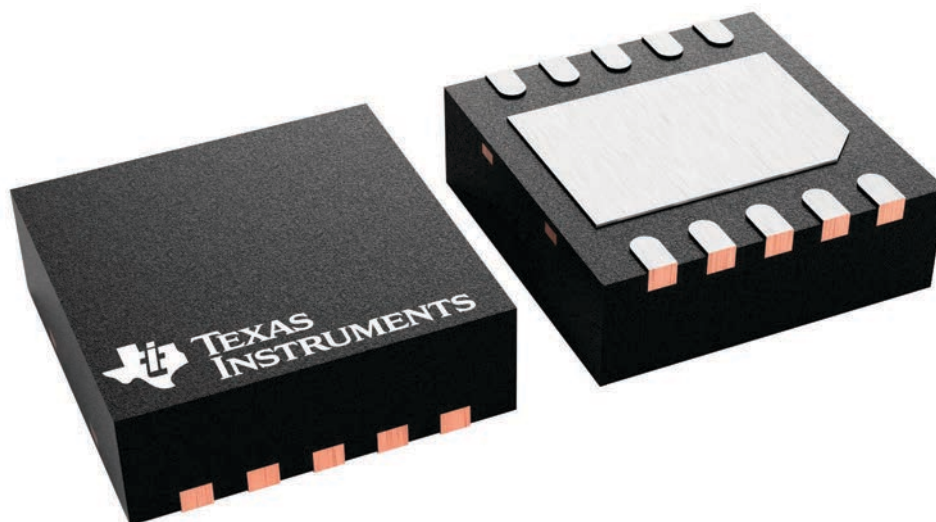

4226193/A



# EXAMPLE BOARD LAYOUT

DRC0010J

VSON - 1 mm max height

PLASTIC SMALL OUTLINE - NO LEAD

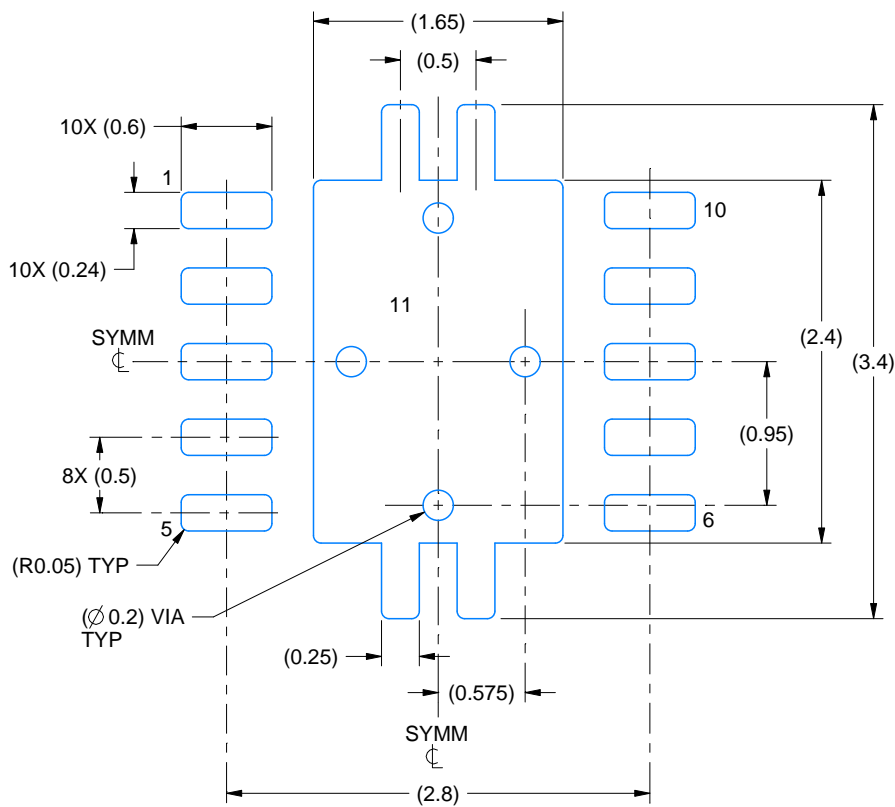

LAND PATTERN EXAMPLE  
EXPOSED METAL SHOWN  
SCALE:20X

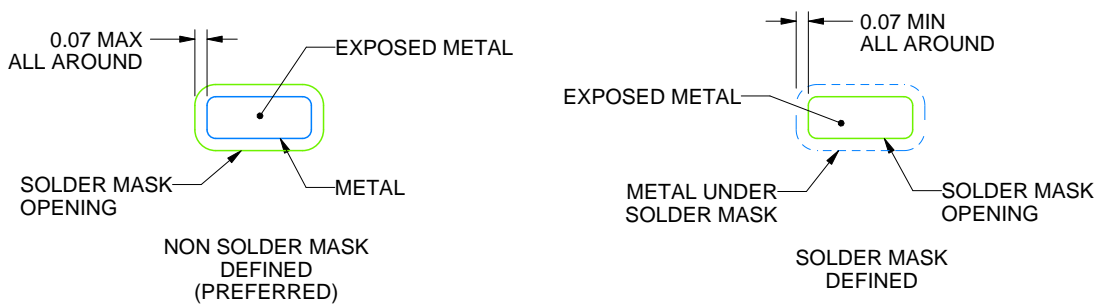

SOLDER MASK DETAILS

4218878/B 07/2018

NOTES: (continued)

4. This package is designed to be soldered to a thermal pad on the board. For more information, see Texas Instruments literature number SLUA271 ([www.ti.com/lit/sluea271](http://www.ti.com/lit/sluea271)).
5. Vias are optional depending on application, refer to device data sheet. If any vias are implemented, refer to their locations shown on this view. It is recommended that vias under paste be filled, plugged or tented.

# EXAMPLE STENCIL DESIGN

DRC0010J

VSON - 1 mm max height

PLASTIC SMALL OUTLINE - NO LEAD

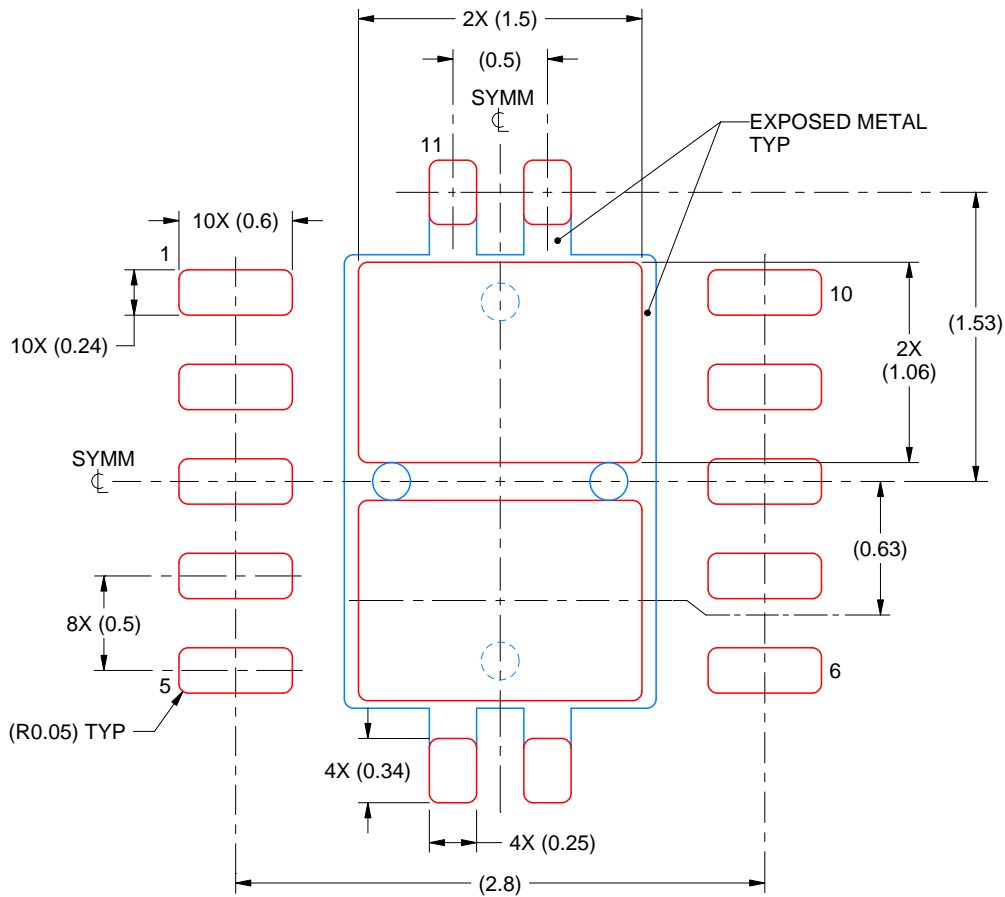

SOLDER PASTE EXAMPLE  
BASED ON 0.125 mm THICK STENCIL

EXPOSED PAD 11:  
80% PRINTED SOLDER COVERAGE BY AREA  
SCALE:25X

4218878/B 07/2018

NOTES: (continued)

6. Laser cutting apertures with trapezoidal walls and rounded corners may offer better paste release. IPC-7525 may have alternate design recommendations.

## IMPORTANT NOTICE AND DISCLAIMER

TI PROVIDES TECHNICAL AND RELIABILITY DATA (INCLUDING DATA SHEETS), DESIGN RESOURCES (INCLUDING REFERENCE DESIGNS), APPLICATION OR OTHER DESIGN ADVICE, WEB TOOLS, SAFETY INFORMATION, AND OTHER RESOURCES "AS IS" AND WITH ALL FAULTS, AND DISCLAIMS ALL WARRANTIES, EXPRESS AND IMPLIED, INCLUDING WITHOUT LIMITATION ANY IMPLIED WARRANTIES OF MERCHANTABILITY, FITNESS FOR A PARTICULAR PURPOSE OR NON-INFRINGEMENT OF THIRD PARTY INTELLECTUAL PROPERTY RIGHTS.

These resources are intended for skilled developers designing with TI products. You are solely responsible for (1) selecting the appropriate TI products for your application, (2) designing, validating and testing your application, and (3) ensuring your application meets applicable standards, and any other safety, security, regulatory or other requirements.

These resources are subject to change without notice. TI grants you permission to use these resources only for development of an application that uses the TI products described in the resource. Other reproduction and display of these resources is prohibited. No license is granted to any other TI intellectual property right or to any third party intellectual property right. TI disclaims responsibility for, and you will fully indemnify TI and its representatives against, any claims, damages, costs, losses, and liabilities arising out of your use of these resources.

TI's products are provided subject to [TI's Terms of Sale](#) or other applicable terms available either on [ti.com](http://ti.com) or provided in conjunction with such TI products. TI's provision of these resources does not expand or otherwise alter TI's applicable warranties or warranty disclaimers for TI products.

TI objects to and rejects any additional or different terms you may have proposed.

Mailing Address: Texas Instruments, Post Office Box 655303, Dallas, Texas 75265  
Copyright © 2022, Texas Instruments Incorporated

## Looking for pricing, stock, or lifecycle information?

Click below to explore more details on WIN SOURCE:

 [View TPS2561QDRCRQ1](#) on WIN SOURCE

 [Texas Instruments](#) Information

## Optimize Your Supply Chain with WIN SOURCE Solutions

-  Global Sourcing Solution
-  Obsolete Management
-  Cost Control Management
-  Shortage Management
-  Alternative Solution
-  Excess Inventory Management