



THE DATASHEET OF TPS2546RTER



TPS2546 USB Charging Port Controller and Power Switch With Load Detection

1 Features

- D+/D– CDP/DCP Modes per USB Battery Charging Specification 1.2
- D+/D– Shorted Mode per Chinese Telecommunication Industry Standard YD/T 1591-2009
- Supports Non-BC1.2 Charging Modes by Automatic Selection:
 - D+/D– Divider Modes 2 V/2.7 V and 2.7 V/2 V
 - D+/D– 1.2-V Mode
- Supports Sleep-Mode Charging and Mouse/Keyboard Wakeup
- Automatic SDP/CDP Switching for Devices That Do Not Connect to CDP Ports
- Load Detection for Power Supply Control in S4/S5 Charging and Port Power Management in All Charge Modes
- Compatible With USB 2.0 and 3.0 Power Switch Requirements
- Integrated 73-mΩ (Typical) High-Side MOSFET
- Adjustable Current-Limit up to 3 A (Typical)
- Operating Range: 4.5 V to 5.5 V
- Max Device Current:
 - 2 μA When Device Disabled
 - 270 μA When Device Enabled
- Drop-In and BOM Compatible With TPS2543
- Available in 16-Pin WQFN (3.00 mm × 3.00 mm) Package
- 8-kV ESD Rating on DM/DP Pins
- UL Listed File No. E169910 and CB certified

2 Applications

- USB Ports (Host and Hubs)
- Notebook and Desktop PCs
- Universal Wall-Charging Adapters

3 Description

The TPS2546 is a USB charging port controller and power switch with an integrated USB 2.0 high-speed data line (D+/D–) switch. TPS2546 provides the electrical signatures on D+/D– to support charging schemes listed under [Feature Description](#). TI tests charging of popular mobile phones, tablets, and media devices with the TPS2546 to ensure compatibility with both BC1.2 compliant, and non-BC1.2 compliant devices.

In addition to charging popular devices, the TPS2546 also supports two distinct power management features, namely, power wake and port power management (PPM) through the STATUS pin. Power wake allows for power supply control in S4/S5 charging and PPM the ability to manage port power in a multi-port application. Additionally, system wake up (from S3) with a mouse/keyboard (both low speed and full speed) is fully supported in the TPS2546.

The TPS2546 73-mΩ power-distribution switch is intended for applications where heavy capacitive loads and short-circuits are likely to be encountered. Two programmable current thresholds provide flexibility for setting current limits and load detect thresholds.

Device Information⁽¹⁾

PART NUMBER	PACKAGE	BODY SIZE (NOM)
TPS2546	WQFN (16)	3.00 mm × 3.00 mm

(1) For all available packages, see the orderable addendum at the end of the data sheet.

Simplified Schematic

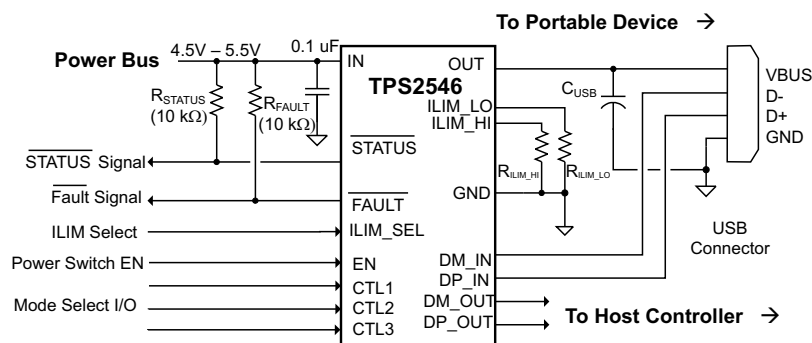

Copyright © 2016, Texas Instruments Incorporated



Table of Contents

1 Features 1 2 Applications 1 3 Description 1 4 Revision History 2 5 Pin Configuration and Functions 3 6 Specifications 4 6.1 Absolute Maximum Ratings 4 6.2 ESD Ratings..... 4 6.3 Recommended Operating Conditions 4 6.4 Thermal Information 5 6.5 Electrical Characteristics..... 5 6.6 Electrical Characteristics: High-Bandwidth Switch.... 6 6.7 Electrical Characteristics: Charging Controller 7 6.8 Typical Characteristics 9 7 Parameter Measurement Information 13 8 Detailed Description 14 8.1 Overview 14 8.2 Functional Block Diagram 15	8.3 Feature Description..... 15 8.4 Device Functional Modes..... 26 9 Application and Implementation 29 9.1 Application Information..... 29 9.2 Typical Application 30 10 Power Supply Recommendations 33 11 Layout 33 11.1 Layout Guidelines 33 11.2 Layout Example 34 12 Device and Documentation Support 35 12.1 Documentation Support 35 12.2 Receiving Notification of Documentation Updates 35 12.3 Community Resources..... 35 12.4 Trademarks 35 12.5 Electrostatic Discharge Caution..... 35 12.6 Glossary 35 13 Mechanical, Packaging, and Orderable Information 35
--------------------------------------------------------------------------------------------------------------------------------------------------------------------------------------------------------------------------------------------------------------------------------------------------------------------------------------------------------------------------------------------------------------------------------------------------------------------------------------------------------------------------------------------------------------------------------------------------------------------------------------------------------------------------------------------------------------------------------------------------------------	------------------------------------------------------------------------------------------------------------------------------------------------------------------------------------------------------------------------------------------------------------------------------------------------------------------------------------------------------------------------------------------------------------------------------------------------------------------------------------------------------------------------------------------------------------------------------------------------------------------------------------------------------------------------------------------------------------------------------------

4 Revision History

NOTE: Page numbers for previous revisions may differ from page numbers in the current version.

Changes from Revision B (January 2016) to Revision C	Page
• Corrected references to images in the <i>Feature Description</i> section	15
• Added text to the <i>Layout Guidelines</i> section	34

Changes from Revision A (February 2013) to Revision B	Page
• Added <i>ESD Ratings</i> table, <i>Feature Description</i> section, <i>Device Functional Modes</i> , <i>Application and Implementation</i> section, <i>Power Supply Recommendations</i> section, <i>Layout</i> section, <i>Device and Documentation Support</i> section, and <i>Mechanical, Packaging, and Orderable Information</i> section.	1

Changes from Original (February 2013) to Revision A	Page
• Changed the device From: Preview To: Production	1

5 Pin Configuration and Functions

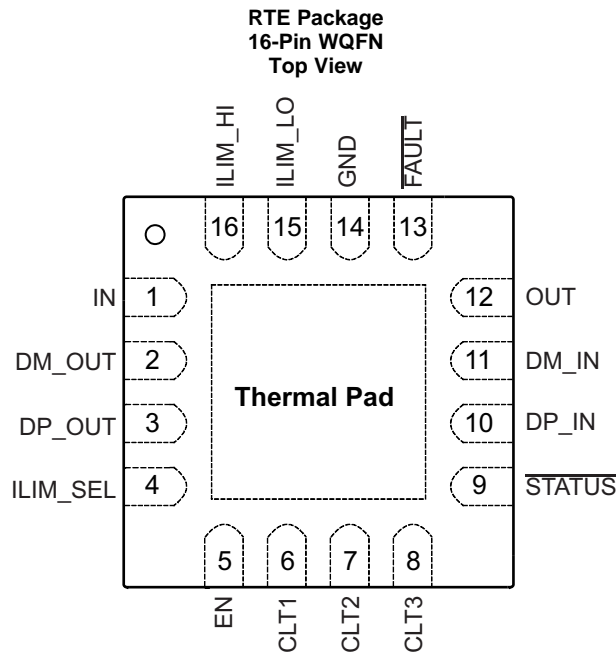

Pin Functions

PIN		TYPE ⁽¹⁾	DESCRIPTION
NO.	NAME		
1	IN	P	Input voltage and supply voltage; connect 0.1 μ F or greater ceramic capacitor from IN to GND as close to the device as possible.
2	DM_OUT	I/O	D– data line to USB host controller.
3	DP_OUT	I/O	D+ data line to USB host controller.
4	ILIM_SEL	I	Logic-level input signal used to control the charging mode, current limit threshold, and load detection; see Table 3 . Can be tied directly to IN or GND without pullup or pulldown resistor.
5	EN	I	Logic-level input for turning the power switch and the signal switches on/off; logic low turns off the signal and power switches and holds OUT in discharge. Can be tied directly to IN or GND without pullup or pulldown resistor.
6	CTL1	I	Logic-level inputs used to control the charging mode and the signal switches; see Table 3 . Can be tied directly to IN or GND without pullup or pulldown resistor.
7	CTL2	I	
8	CTL3	I	
9	STATUS	O	Active-low open-drain output, asserted in load detection conditions.
10	DP_IN	I/O	D+ data line to downstream connector.
11	DM_IN	I/O	D– data line to downstream connector.
12	OUT	P	Power-switch output.
13	FAULT	O	Active-low open-drain output, asserted during overtemperature or current limit conditions.
14	GND	P	Ground connection.
15	ILIM_LO	I	External resistor connection used to set the low current-limit threshold and the load detection current threshold. A resistor to ILIM_LO is optional; see Current-Limit Settings in Detailed Description .
16	ILIM_HI	I	External resistor connection used to set the high-current-limit threshold.
—	Thermal Pad	—	Internally connected to GND; used to heatsink the part to the circuit board traces. Connect to GND plane.

(1) G = ground, I = input, O = output, P = power.

6 Specifications

6.1 Absolute Maximum Ratings

Over operating free-air temperature range (unless otherwise noted)⁽¹⁾

		MIN	MAX	UNIT
Voltage	IN, EN, ILIM_LO, ILIM_HI, $\overline{\text{FAULT}}$, $\overline{\text{STATUS}}$, ILIM_SEL, CTL1, CTL2, CTL3, OUT	-0.3	7	V
	IN to OUT	-7	7	
	DP_IN, DM_IN, DP_OUT, DM_OUT	-0.3	(IN + 0.3) or 5.7	
Input clamp current	DP_IN, DM_IN, DP_OUT, DM_OUT		±20	mA
Continuous current in SDP or CDP mode	DP_IN to DP_OUT or DM_IN to DM_OUT		±100	mA
Continuous current in BC1.2 DCP mode	DP_IN to DM_IN		±50	mA
Continuous output current	OUT		Internally limited	
Continuous output sink current	$\overline{\text{FAULT}}$, $\overline{\text{STATUS}}$		25	mA
Continuous output source current	ILIM_LO, ILIM_HI		Internally limited	mA
Operating junction temperature, T _J		-40	Internally limited	°C

(1) Stresses beyond those listed under *Absolute Maximum Ratings* may cause permanent damage to the device. These are stress ratings only, which do not imply functional operation of the device at these or any other conditions beyond those indicated under *Recommended Operating Conditions*. Exposure to absolute-maximum-rated conditions for extended periods may affect device reliability.

6.2 ESD Ratings

			VALUE	UNIT
V _(ESD) Electrostatic discharge	Human-body model (HBM), per ANSI/ESDA/JEDEC JS-001 ⁽¹⁾	HBM	±2000	V
		HBM wrt GND and each other, DP_IN, DM_IN, OUT	±8000	
	Charged-device model (CDM), per JEDEC specification JESD22-C101 ⁽²⁾		±500	

(1) JEDEC document JEP155 states that 500-V HBM allows safe manufacturing with a standard ESD control process.

(2) JEDEC document JEP157 states that 250-V CDM allows safe manufacturing with a standard ESD control process.

6.3 Recommended Operating Conditions

voltages are referenced to GND (unless otherwise noted)

		MIN	MAX	UNIT
V _{IN}	Input voltage, IN	4.5	5.5	V
	Input voltage, logic-level inputs, EN, CTL1, CTL2, CTL3, ILIM_SEL	0	5.5	V
	Input voltage, data line inputs, DP_IN, DM_IN, DP_OUT, DM_OUT	0	V _{IN}	V
V _{IH}	High-level input voltage, EN, CTL1, CTL2, CTL3, ILIM_SEL	1.8		V
V _{IL}	Low-level input voltage, EN, CTL1, CTL2, CTL3, ILIM_SEL		0.8	V
	Continuous current, data line inputs, SDP or CDP mode, DP_IN to DP_OUT, DM_IN to DM_OUT		±30	mA
	Continuous current, data line inputs, BC1.2 DCP mode, DP_IN to DM_IN		±15	mA
I _{OUT}	Continuous output current, OUT	0	2.5	A
	Continuous output sink current, $\overline{\text{FAULT}}$, $\overline{\text{STATUS}}$	0	10	mA
R _{ILIM_XX}	Current-limit set resistors	16.9	750	kΩ
T _J	Operating virtual junction temperature	-40	125	°C

6.4 Thermal Information

THERMAL METRIC ⁽¹⁾		TPS2546	UNIT
		RTE (WQFN)	
		16 PINS	
R _{θJA}	Junction-to-ambient thermal resistance	53.4	°C/W
R _{θJC(top)}	Junction-to-case (top) thermal resistance	51.4	°C/W
R _{θJB}	Junction-to-board thermal resistance	17.2	°C/W
ψ _{JT}	Junction-to-top characterization parameter	3.7	°C/W
ψ _{JB}	Junction-to-board characterization parameter	20.7	°C/W
R _{θJC(bot)}	Junction-to-case (bottom) thermal resistance	3.9	°C/W

(1) For more information about traditional and new thermal metrics, see the [Semiconductor and IC Package Thermal Metrics](#) application report.

6.5 Electrical Characteristics

Unless otherwise noted: $-40 \leq T_J \leq 125^\circ\text{C}$, $4.5 \text{ V} \leq V_{\text{IN}} \leq 5.5 \text{ V}$, $V_{\text{EN}} = V_{\text{IN}}$, $V_{\text{ILIM_SEL}} = V_{\text{IN}}$, $V_{\text{CTL1}} = V_{\text{CTL2}} = V_{\text{CTL3}} = V_{\text{IN}}$. $R_{\text{FAULT}} = R_{\text{STATUS}} = 10 \text{ k}\Omega$, $R_{\text{ILIM_HI}} = 20 \text{ k}\Omega$, $R_{\text{ILIM_LO}} = 80.6 \text{ k}\Omega$. Positive currents are into pins. Typical values are at 25°C . All voltages are with respect to GND.

PARAMETER		TEST CONDITIONS	MIN	TYP	MAX	UNIT
POWER SWITCH						
R _{DS(on)}	ON resistance ⁽¹⁾	T _J = 25°C, I _{OUT} = 2 A		73	84	mΩ
		-40°C ≤ T _J ≤ 85°C, I _{OUT} = 2 A		73	105	
		-40°C ≤ T _J ≤ 125°C, I _{OUT} = 2 A		73	120	
t _r	OUT voltage rise time	V _{IN} = 5 V, C _L = 1 μF, R _L = 100 Ω (see Figure 23 and Figure 24)	0.7	1	1.6	ms
t _f	OUT voltage fall time		0.2	0.35	0.5	
t _{on}	OUT voltage turnon time	V _{IN} = 5 V, C _L = 1 μF, R _L = 100 Ω (see Figure 23 and Figure 25)		2.7	4	ms
t _{off}	OUT voltage turnoff time			1.7	3	
I _{REV}	Reverse leakage current	V _{OUT} = 5.5 V, V _{IN} = V _{EN} = 0 V, -40 ≤ T _J ≤ 85°C, Measure I _{OUT}			2	μA
DISCHARGE						
R _{DCHG}	OUT discharge resistance		400	500	630	Ω
t _{DCHG_L}	Long OUT discharge hold time	Time V _{OUT} < 0.7 V (see Figure 26)	1.3	2	2.9	s
t _{DCHG_S}	Short OUT discharge hold time	Time V _{OUT} < 0.7 V (see Figure 26)	205	310	450	ms
EN, ILIMSEL, CTL1, CTL2, CTL3 INPUTS						
	Input pin rising logic threshold voltage		1	1.35	1.7	V
	Input pin falling logic threshold voltage		0.85	1.15	1.45	
	Hysteresis ⁽²⁾			200		mV
	Input current	Pin voltage = 0 V or 5.5 V	-0.5		0.5	μA
ILIMSEL CURRENT LIMIT						
I _{OS}	OUT short-circuit current limit ⁽¹⁾	V _{ILIM_SEL} = 0 V, R _{ILIM_LO} = 210 kΩ	205	240	275	mA
		V _{ILIM_SEL} = 0 V, R _{ILIM_LO} = 80.6 kΩ	575	625	680	
		V _{ILIM_SEL} = 0 V, R _{ILIM_LO} = 22.1 kΩ	2120	2275	2430	
		V _{ILIM_SEL} = V _{IN} , R _{ILIM_HI} = 20 kΩ	2340	2510	2685	
		V _{ILIM_SEL} = V _{IN} , R _{ILIM_HI} = 16.9 kΩ	2770	2970	3170	
t _{iOS}	Response time to OUT short-circuit ⁽²⁾	V _{IN} = 5 V, R = 0.1Ω, lead length = 2 inches (see Figure 27)		1.5		μs

(1) Pulse-testing techniques maintain junction temperature close to ambient temperature; Thermal effects must be taken into account separately.

(2) These parameters are provided for reference only and do not constitute part of TI's published device specifications for purposes of TI's product warranty.

Electrical Characteristics (continued)

Unless otherwise noted: $-40 \leq T_J \leq 125^\circ\text{C}$, $4.5 \text{ V} \leq V_{IN} \leq 5.5 \text{ V}$, $V_{EN} = V_{IN}$, $V_{ILIM_SEL} = V_{IN}$, $V_{CTL1} = V_{CTL2} = V_{CTL3} = V_{IN}$. $R_{\overline{\text{FAULT}}} = R_{\overline{\text{STATUS}}} = 10 \text{ k}\Omega$, $R_{ILIM_HI} = 20 \text{ k}\Omega$, $R_{ILIM_LO} = 80.6 \text{ k}\Omega$. Positive currents are into pins. Typical values are at 25°C . All voltages are with respect to GND.

PARAMETER		TEST CONDITIONS	MIN	TYP	MAX	UNIT
SUPPLY CURRENT						
I_{IN_OFF}	Disabled IN supply current	$V_{EN} = 0 \text{ V}$, $V_{OUT} = 0 \text{ V}$, $-40 \leq T_J \leq 85^\circ\text{C}$		0.1	2	μA
I_{IN_ON}	Enabled IN supply current	$V_{CTL1} = V_{CTL2} = V_{IN}$, $V_{CTL3} = 0 \text{ V}$, $V_{ILIM_SEL} = 0 \text{ V}$		165	220	μA
		$V_{CTL1} = V_{CTL2} = V_{CTL3} = V_{IN}$, $V_{ILIM_SEL} = 0 \text{ V}$		175	230	
		$V_{CTL1} = V_{CTL2} = V_{IN}$, $V_{CTL3} = 0 \text{ V}$, $V_{ILIM_SEL} = V_{IN}$		185	240	
		$V_{CTL1} = V_{CTL2} = V_{IN}$, $V_{CTL3} = V_{IN}$, $V_{ILIM_SEL} = V_{IN}$		195	250	
		$V_{CTL1} = 0 \text{ V}$, $V_{CTL2} = V_{CTL3} = V_{IN}$		215	270	
UNDERVOLTAGE LOCKOUT						
V_{UVLO}	IN rising UVLO threshold voltage		3.9	4.1	4.3	V
	Hysteresis ⁽²⁾			100		mV
FAULT						
	Output low voltage	$I_{\overline{\text{FAULT}}} = 1 \text{ mA}$			100	mV
	OFF-state leakage	$V_{\overline{\text{FAULT}}} = 5.5 \text{ V}$			1	μA
	Overcurrent $\overline{\text{FAULT}}$ rising and falling deglitch		5	8.2	12	ms
STATUS						
	Output low voltage	$I_{\overline{\text{STATUS}}} = 1 \text{ mA}$			100	mV
	OFF-state leakage	$V_{\overline{\text{STATUS}}} = 5.5 \text{ V}$			1	μA
THERMAL SHUTDOWN						
	Thermal shutdown threshold		155			$^\circ\text{C}$
	Thermal shutdown threshold in current-limit		135			
	Hysteresis ⁽²⁾			20		

6.6 Electrical Characteristics: High-Bandwidth Switch

Unless otherwise noted: $-40 \leq T_J \leq 125^\circ\text{C}$, $4.5 \text{ V} \leq V_{IN} \leq 5.5 \text{ V}$, $V_{EN} = V_{IN}$, $V_{ILIM_SEL} = V_{IN}$, $V_{CTL1} = V_{CTL2} = V_{CTL3} = V_{IN}$. $R_{\overline{\text{FAULT}}} = R_{\overline{\text{STATUS}}} = 10 \text{ k}\Omega$, $R_{ILIM_HI} = 20 \text{ k}\Omega$, $R_{ILIM_LO} = 80.6 \text{ k}\Omega$. Positive currents are into pins. Typical values are at 25°C . All voltages are with respect to GND.

PARAMETER		TEST CONDITIONS	MIN	TYP	MAX	UNIT
HIGH-BANDWIDTH ANALOG SWITCH						
DP/DM switch ON resistance		$V_{DP/DM_OUT} = 0 \text{ V}$, $I_{DP/DM_IN} = 30 \text{ mA}$		2	4	Ω
		$V_{DP/DM_OUT} = 2.4 \text{ V}$, $I_{DP/DM_IN} = -15 \text{ mA}$		3	6	
Switch resistance mismatch between DP / DM channels		$V_{DP/DM_OUT} = 0 \text{ V}$, $I_{DP/DM_IN} = 30 \text{ mA}$		0.05	0.15	Ω
		$V_{DP/DM_OUT} = 2.4 \text{ V}$, $I_{DP/DM_IN} = -15 \text{ mA}$		0.05	0.15	
DP/DM switch OFF-state capacitance ⁽¹⁾		$V_{EN} = 0 \text{ V}$, $V_{DP/DM_IN} = 0.3 \text{ V}$, $V_{ac} = 0.6 \text{ V}_{pk-pk}$, $f = 1 \text{ MHz}$		3	3.6	pF
DP/DM switch ON-state capacitance ⁽²⁾		$V_{DP/DM_IN} = 0.3 \text{ V}$, $V_{ac} = 0.6 \text{ V}_{pk-pk}$, $f = 1 \text{ MHz}$		5.4	6.2	pF
O_{IRR}	OFF-state isolation ⁽³⁾	$V_{EN} = 0 \text{ V}$, $f = 250 \text{ MHz}$		33		dB
X_{TALK}	ON-state cross channel isolation ⁽³⁾	$f = 250 \text{ MHz}$		52		dB
	OFF-state leakage current	$V_{EN} = 0 \text{ V}$, $V_{DP/DM_IN} = 3.6 \text{ V}$, $V_{DP/DM_OUT} = 0 \text{ V}$, measure I_{DP/DM_OUT}		0.1	1.5	μA
BW	Bandwidth (-3 dB) ⁽³⁾	$R_L = 50 \Omega$		2.6		GHz
t_{pd}	Propagation delay ⁽³⁾			0.25		ns

(1) The resistance in series with the parasitic capacitance to GND is typically 250Ω .

(2) The resistance in series with the parasitic capacitance to GND is typically 150Ω .

(3) These parameters are provided for reference only and do not constitute part of TI's published device specifications for purposes of TI's product warranty.

Electrical Characteristics: High-Bandwidth Switch (continued)

Unless otherwise noted: $-40 \leq T_J \leq 125^\circ\text{C}$, $4.5 \text{ V} \leq V_{\text{IN}} \leq 5.5 \text{ V}$, $V_{\text{EN}} = V_{\text{IN}}$, $V_{\text{ILIM_SEL}} = V_{\text{IN}}$, $V_{\text{CTL1}} = V_{\text{CTL2}} = V_{\text{CTL3}} = V_{\text{IN}}$. $R_{\text{FAULT}} = R_{\text{STATUS}} = 10 \text{ k}\Omega$, $R_{\text{ILIM_HI}} = 20 \text{ k}\Omega$, $R_{\text{ILIM_LO}} = 80.6 \text{ k}\Omega$. Positive currents are into pins. Typical values are at 25°C . All voltages are with respect to GND.

PARAMETER		TEST CONDITIONS	MIN	TYP	MAX	UNIT
t_{SK}	Skew between opposite transitions of the same port ($t_{\text{PHL}} - t_{\text{PLH}}$)			0.1	0.2	ns

6.7 Electrical Characteristics: Charging Controller

Unless otherwise noted: $-40 \leq T_J \leq 125^\circ\text{C}$, $4.5 \text{ V} \leq V_{\text{IN}} \leq 5.5 \text{ V}$, $V_{\text{EN}} = V_{\text{IN}}$, $V_{\text{ILIM_SEL}} = V_{\text{IN}}$, $V_{\text{CTL1}} = 0 \text{ V}$, $V_{\text{CTL2}} = V_{\text{CTL3}} = V_{\text{IN}}$. $R_{\text{FAULT}} = R_{\text{STATUS}} = 10 \text{ k}\Omega$, $R_{\text{ILIM_HI}} = 20 \text{ k}\Omega$, $R_{\text{ILIM_LO}} = 80.6 \text{ k}\Omega$. Positive currents are into pins. Typical values are at 25°C . All voltages are with respect to GND.

PARAMETER		TEST CONDITIONS	MIN	TYP	MAX	UNIT		
SHORTED MODE (BC1.2 DCP)								
DP_IN / DM_IN shorting resistance		$V_{\text{CTL1}} = V_{\text{IN}}$, $V_{\text{CTL2}} = V_{\text{CTL3}} = 0 \text{ V}$		125	200	Ω		
1.2 V MODE								
DP_IN /DM_IN output voltage		$V_{\text{CTL1}} = V_{\text{IN}}$, $V_{\text{CTL2}} = V_{\text{CTL3}} = 0 \text{ V}$	1.19	1.25	1.31	V		
DP_IN /DM_IN output impedance			60	75	94	k Ω		
DIVIDER1 MODE								
DP_IN divider1 output voltage		$V_{\text{CTL1}} = V_{\text{IN}}$, $V_{\text{CTL2}} = V_{\text{CTL3}} = 0 \text{ V}$	1.9	2	2.1	V		
DM_IN divider1 output voltage			2.57	2.7	2.84	V		
DP_IN output impedance			8	10.5	12.5	k Ω		
DM_IN output impedance			8	10.5	12.5	k Ω		
DIVIDER2 MODE								
DP_IN divider2 output voltage		IOUT = 1 A	2.57	2.7	2.84	V		
DM_IN divider2 output voltage			1.9	2	2.1	V		
DP_IN output impedance			8	10.5	12.5	k Ω		
DM_IN output impedance			8	10.5	12.5	k Ω		
CHARGING DOWNSTREAM PORT								
$V_{\text{DM_SRC}}$	DM_IN CDP output voltage	$V_{\text{CTL1}} = V_{\text{CTL2}} = V_{\text{CTL3}} = V_{\text{IN}}$	$V_{\text{DP_IN}} = 0.6 \text{ V}$, $-250 \mu\text{A} < I_{\text{DM_IN}} < 0 \mu\text{A}$		0.5	0.6	0.7	V
$V_{\text{DAT_REF}}$	DP_IN rising lower window threshold for $V_{\text{DM_SRC}}$ activation	$V_{\text{CTL1}} = V_{\text{CTL2}} = V_{\text{CTL3}} = V_{\text{IN}}$	0.25		0.4	V		
	Hysteresis ⁽¹⁾			50		mV		
$V_{\text{LGC_SRC}}$	DP_IN rising upper window threshold for $V_{\text{DM_SRC}}$ de-activation		0.8		1	V		
	Hysteresis ⁽¹⁾			100		mV		
$I_{\text{DP_SINK}}$	DP_IN sink current	$V_{\text{CTL1}} = V_{\text{CTL2}} = V_{\text{CTL3}} = V_{\text{IN}}$	$V_{\text{DP_IN}} = 0.6 \text{ V}$		40	70	100	μA
LOAD DETECT – NON-POWER WAKE								
I_{LD}	IOUT rising load detect current threshold	$V_{\text{CTL1}} = V_{\text{CTL2}} = V_{\text{CTL3}} = V_{\text{IN}}$	635	700	765	mA		
	Hysteresis ⁽¹⁾			50		mA		
$t_{\text{LD_SET}}$	Load detect set time		140	200	275	ms		
	Load detect reset time		1.9	3	4.2	s		

(1) These parameters are provided for reference only and do not constitute part of Texas Instrument's published device specifications for purposes of Texas Instrument's product warranty.

Electrical Characteristics: Charging Controller (continued)

Unless otherwise noted: $-40 \leq T_J \leq 125^\circ\text{C}$, $4.5\text{ V} \leq V_{\text{IN}} \leq 5.5\text{ V}$, $V_{\text{EN}} = V_{\text{IN}}$, $V_{\text{ILIM_SEL}} = V_{\text{IN}}$, $V_{\text{CTL1}} = 0\text{ V}$, $V_{\text{CTL2}} = V_{\text{CTL3}} = V_{\text{IN}}$. $R_{\text{FAULT}} = R_{\text{STATUS}} = 10\text{ k}\Omega$, $R_{\text{ILIM_HI}} = 20\text{ k}\Omega$, $R_{\text{ILIM_LO}} = 80.6\text{ k}\Omega$. Positive currents are into pins. Typical values are at 25°C . All voltages are with respect to GND.

PARAMETER		TEST CONDITIONS	MIN	TYP	MAX	UNIT
LOAD DETECT – POWER WAKE						
$I_{\text{OS_PW}}$	Power wake short-circuit current limit	$V_{\text{CTL1}} = V_{\text{CTL2}} = 0\text{ V}$, $V_{\text{CTL3}} = V_{\text{IN}}$	32	55	78	mA
	I_{OUT} falling power wake reset current detection threshold		23	45	67	mA
	Reset current hysteresis ⁽¹⁾			5		mA
	Power wake reset time		10.7	15	20.6	s

6.8 Typical Characteristics

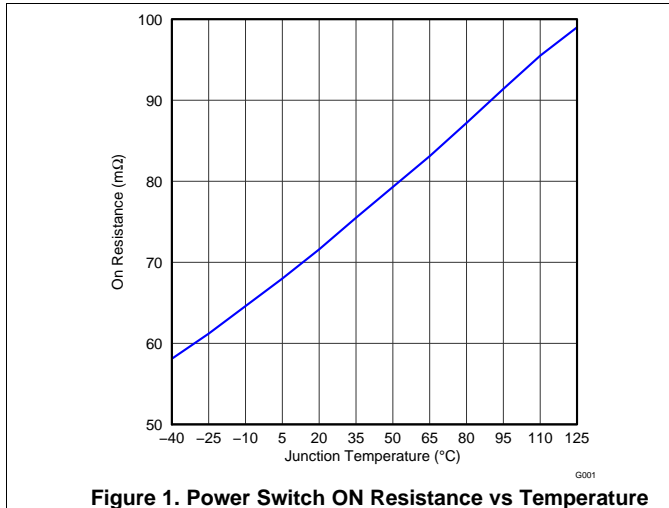

Figure 1. Power Switch ON Resistance vs Temperature

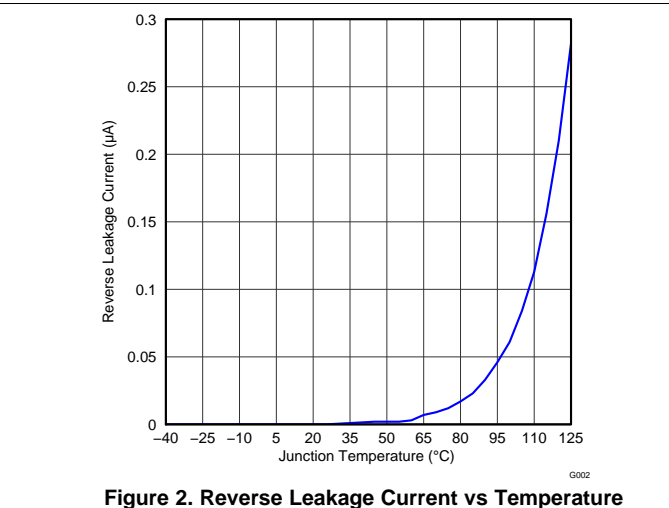

Figure 2. Reverse Leakage Current vs Temperature

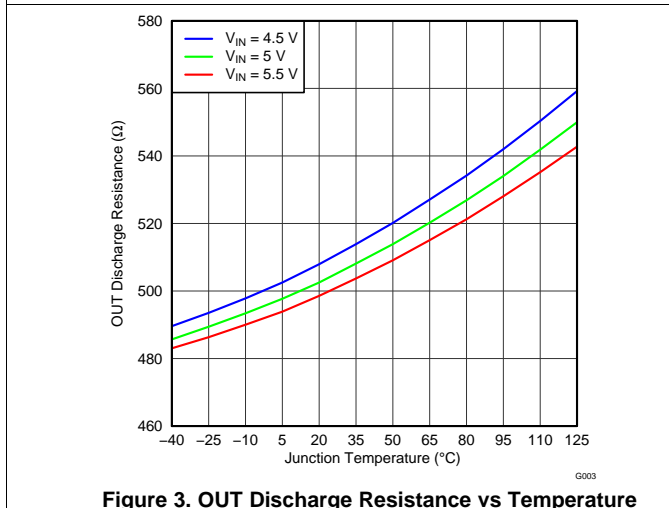

Figure 3. OUT Discharge Resistance vs Temperature

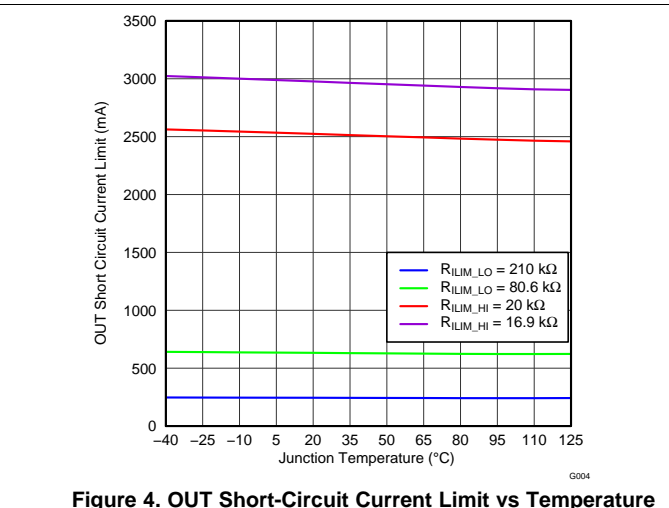

Figure 4. OUT Short-Circuit Current Limit vs Temperature

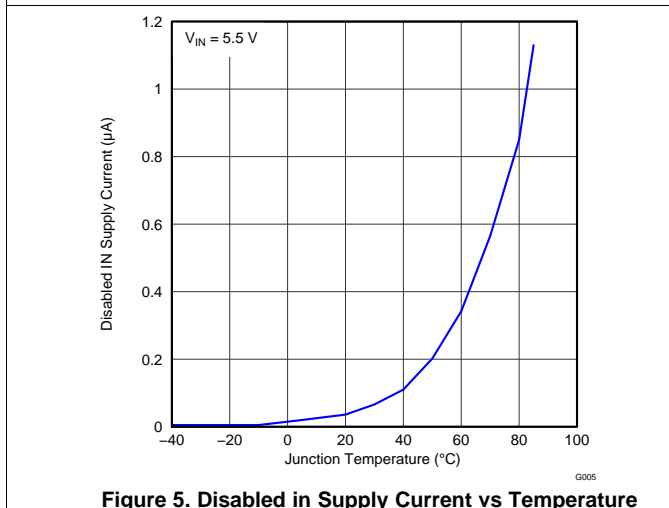

Figure 5. Disabled in Supply Current vs Temperature

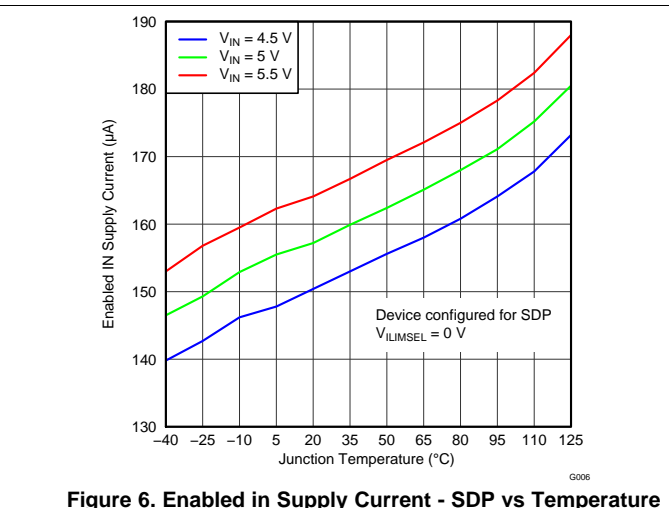

Figure 6. Enabled in Supply Current - SDP vs Temperature

Typical Characteristics (continued)

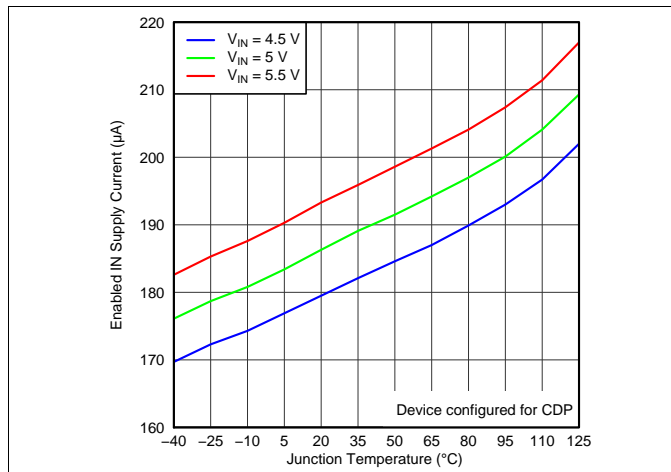

Figure 7. Enabled in Supply Current - CDP vs Temperature

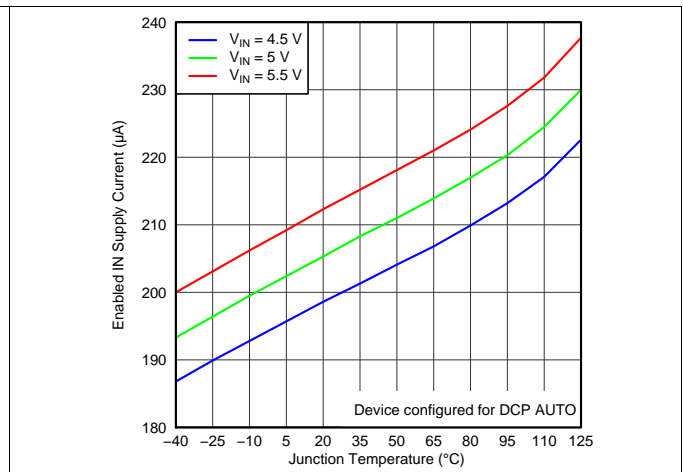

Figure 8. Enabled in Supply Current - DCP Auto vs Temperature

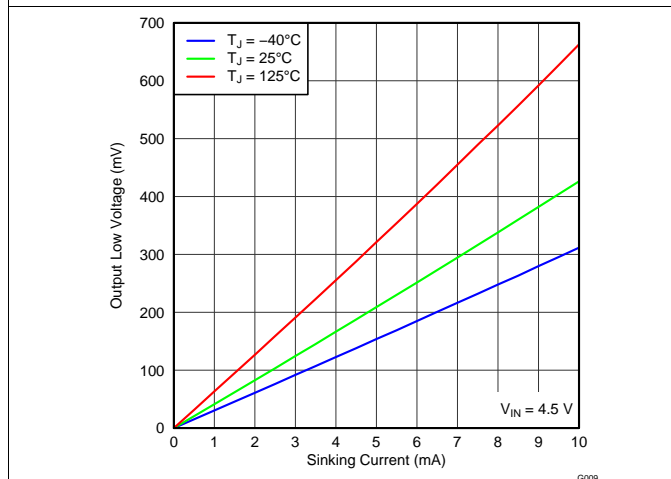

Figure 9. Status and Fault Output Low Voltage vs Sinking Current

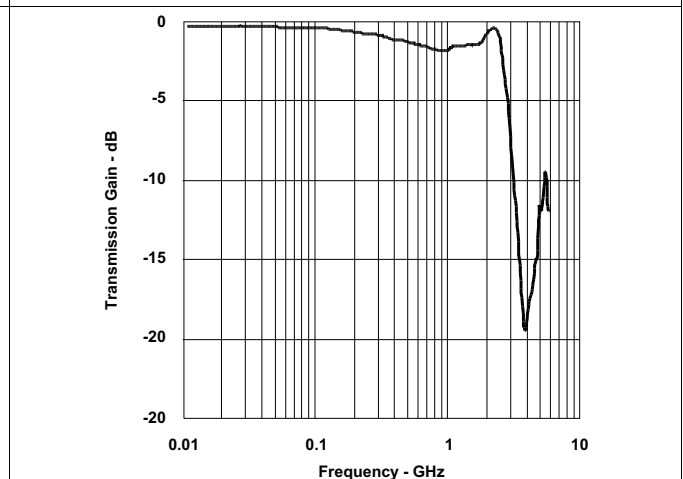

Figure 10. Data Transmission Characteristics vs Frequency

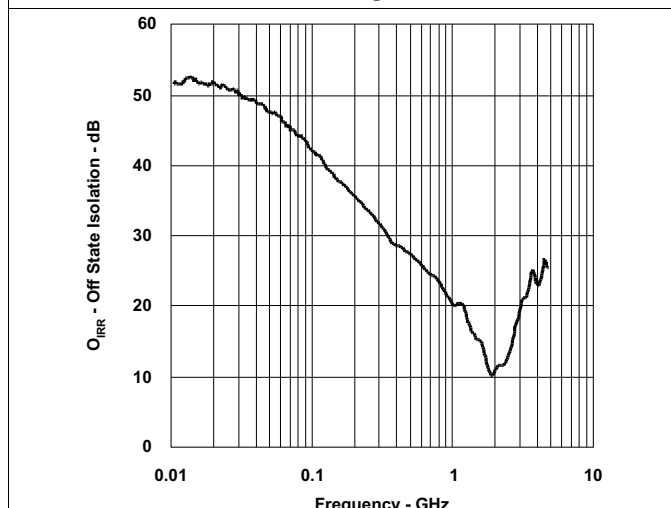

Figure 11. OFF-State Data Switch Isolation vs Frequency

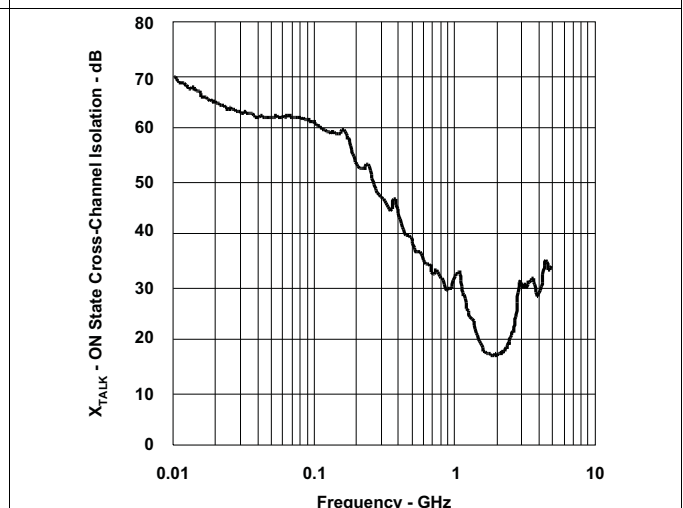

Figure 12. ON-State Cross-Channel Isolation vs Frequency

Typical Characteristics (continued)

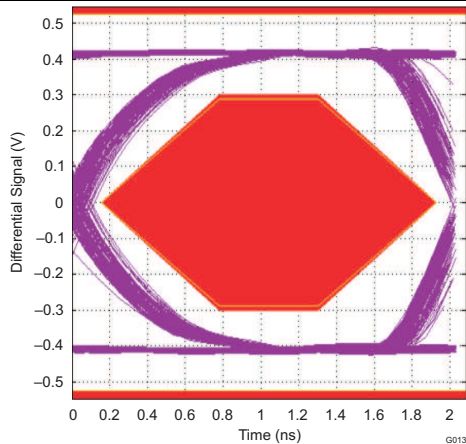

Figure 13. Eye Diagram Using USB Compliance Test Pattern (With No Switch)

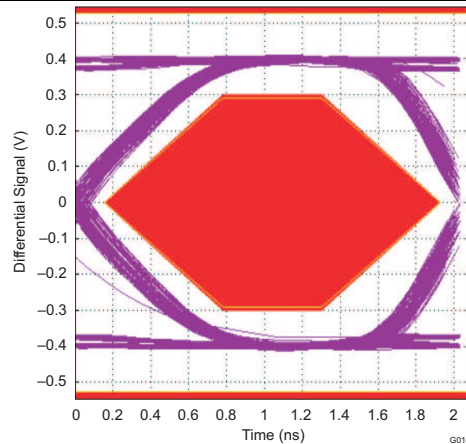

Figure 14. Eye Diagram Using USB Compliance Test Pattern (With Data Switch)

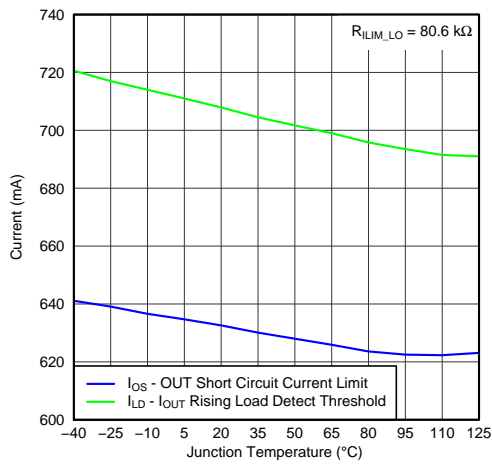

Figure 15. IOU T Rising Load Detect Threshold and Out Short-Circuit Current Limit vs Temperature

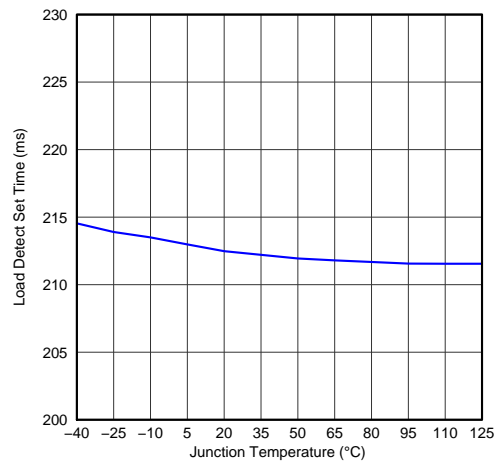

Figure 16. Load Detect Set Time vs Temperature

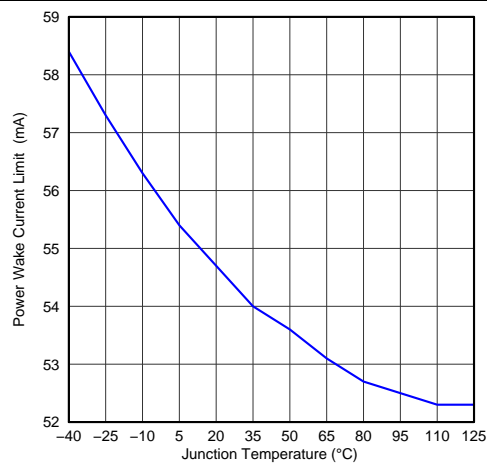

Figure 17. Power Wake Current Limit vs Temperature

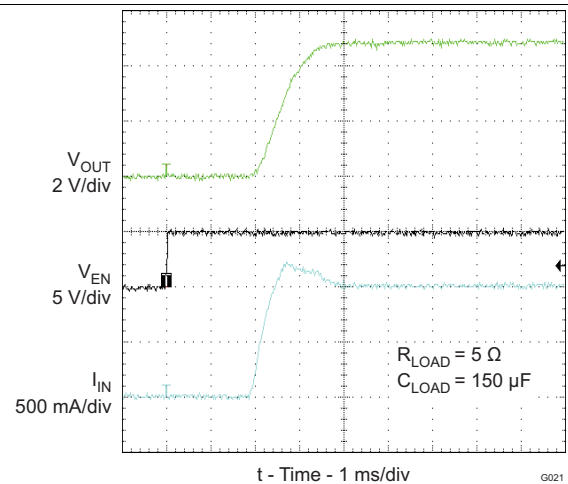

Figure 18. Turnon Response

Typical Characteristics (continued)

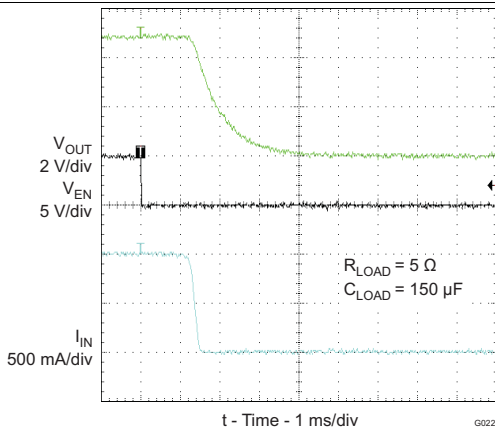

Figure 19. Turnoff Response

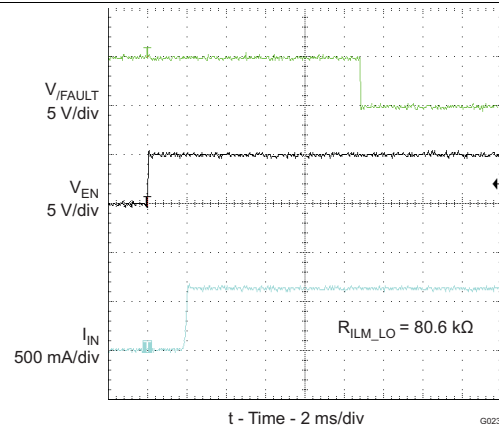

Figure 20. Device Enabled into Short-Circuit

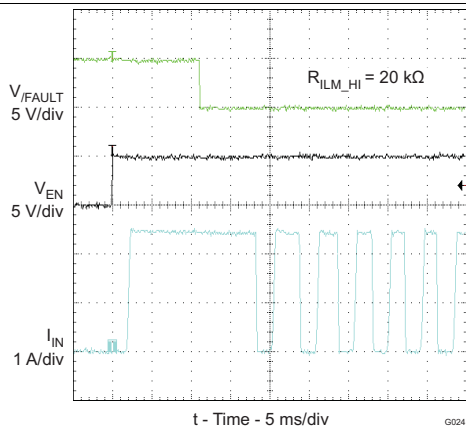

Figure 21. Device Enabled into Short-Circuit - Thermal Cycling

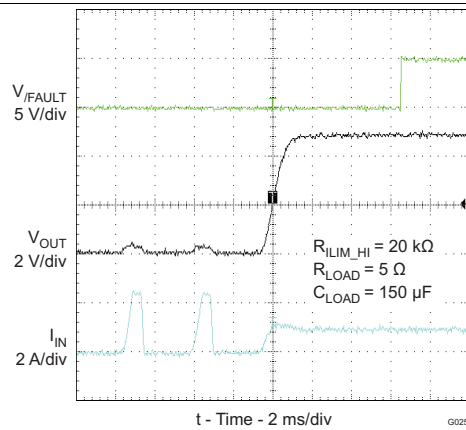

Figure 22. Short-Circuit to Full Load Recovery

7 Parameter Measurement Information

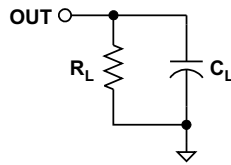

Figure 23. Out Rise/Fall Test Load

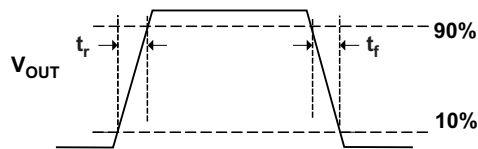

Figure 24. Power-ON and OFF Timing

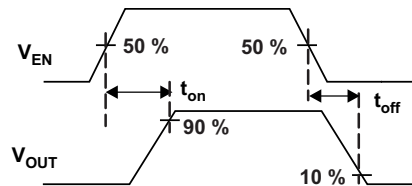

Figure 25. Enable Timing, Active High Enable

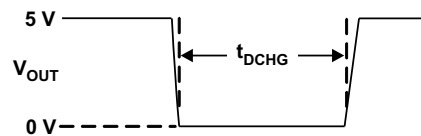

Figure 26. Out Discharge During Mode Change

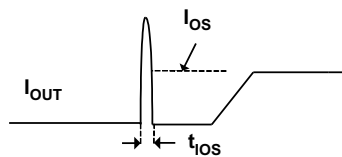

Figure 27. Output Short-Circuit Parameters

8 Detailed Description

8.1 Overview

The following overview references various industry standards. TI recommends consulting the most up-to-date standard to ensure the most recent and accurate information. Rechargeable portable equipment requires an external power source to charge its batteries. USB ports are a convenient location for charging, because of an available 5-V power source. Universally accepted standards are required to make sure host and client-side devices operate together in a system to ensure power management requirements are met. Traditionally, host ports following the USB 2.0 specification must provide at least 500 mA to downstream client-side devices. Because multiple USB devices can attach to a single USB port through a bus-powered hub, it is the responsibility of the client-side device to negotiate its power allotment from the host, ensuring the total current draw does not exceed 500 mA. In general, each USB device is granted 100 mA, and may request more current in 100-mA unit steps up to 500 mA. The host may grant or deny based on the available current. A USB 3.0 host port not only provides higher data rate than USB 2.0 port, but also raises the unit load from 100 mA to 150 mA. It is also required to provide a minimum current of 900 mA to downstream client-side devices.

Additionally, the success of USB makes the mini-USB connector a popular choice for wall adapter cables. This allows a portable device to charge from both a wall adapter, and USB port with only one connector. As USB charging has gained popularity, the 500-mA minimum defined by USB 2.0 or 900 mA for USB 3.0 has become insufficient for many handset and personal media players, which need a higher charging rate. Wall adapters can provide much more current than 500 mA/900 mA. Several new standards have been introduced, defining protocol handshaking methods that allow host and client devices to acknowledge and draw additional current beyond the 500 mA/900 mA minimum defined by USB 2.0 and 3.0, while still using a single micro-USB input connector.

The TPS2546 supports four of the most common USB charging schemes found in popular handheld media and cellular devices:

- USB Battery Charging Specification BC1.2
- Chinese Telecommunications Industry Standard YD/T 1591-2009
- Divider Mode
- 1.2-V Mode

YD/T 1591-2009 is a subset of BC1.2 specifications supported by vast majority of devices that implement USB charging. Divider and 1.2-V charging schemes are supported in devices from specific, yet popular device makers.

BC1.2 lists three different port types:

- Standard Downstream Port (SDP)
- Charging Downstream Port (CDP)
- Dedicated Charging Port (DCP)

BC1.2 defines a charging port as a downstream facing USB port that provides power for charging portable equipment. Under this definition, CDP and DCP are defined as charging ports.

8.2 Functional Block Diagram

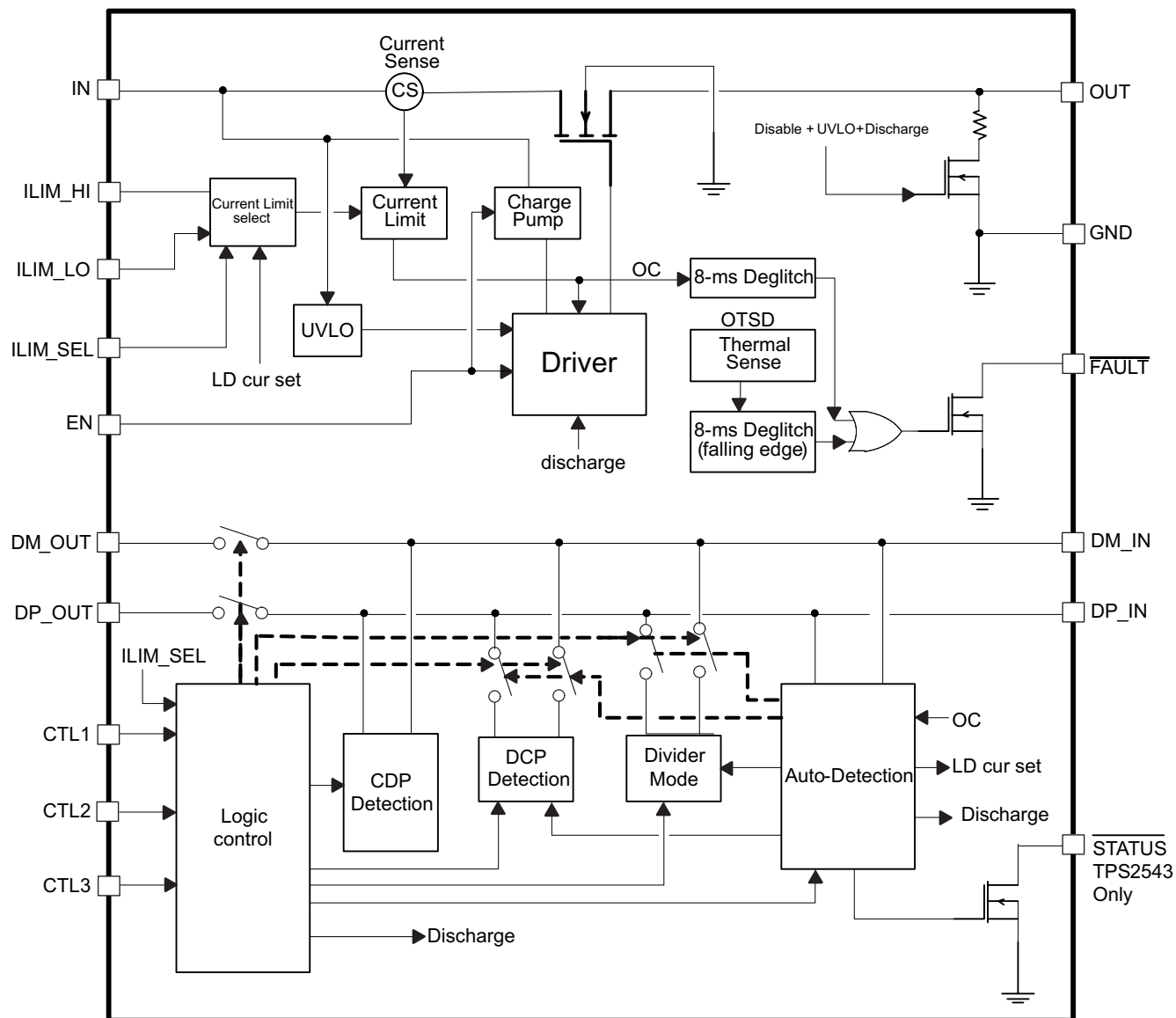

Copyright © 2016, Texas Instruments Incorporated

8.3 Feature Description

8.3.1 Standard Downstream Port (SDP) USB 2.0/USB 3.0

An SDP is a traditional USB port that follows USB 2.0 and 3.0 protocol, and supplies a minimum of 500 mA for USB 2.0 and 900 mA for USB 3.0 per port. USB 2.0 and 3.0 communications is supported, and the host controller must be active to allow charging. TPS2546 supports SDP mode in system power state S0, when system is completely powered ON, and fully operational. For more details on control pin (CTL1-CTL3) settings to program this state, see [Table 3](#).

Feature Description (continued)

8.3.2 Charging Downstream Port (CDP)

A CDP is a USB port that follows USB BC1.2 and supplies a minimum of 1.5 A per port. It provides power and meets USB 2.0 requirements for device enumeration. USB 2.0 communications is supported, and the host controller must be active to allow charging. What separates a CDP from an SDP is the host-charge handshaking logic that identifies this port as a CDP. A CDP is identifiable by a compliant BC1.2 client device, and allows for additional current draw by the client device.

The CDP process is done in two steps. During step one, the portable equipment outputs a nominal 0.6-V output on the D+ line, and reads the voltage input on the D– line. The portable device detects it is connected to an SDP if the voltage is less than the nominal data detect voltage of 0.3 V. The portable device detects that it is connected to a Charging Port if the D– voltage is greater than the nominal data detect voltage of 0.3 V, and optionally less than 0.8 V.

The second step is necessary for portable equipment to determine if it is connected to CDP or DCP. The portable device outputs a nominal 0.6 V output on its D– line, and reads the voltage input on its D+ line. The portable device detects it is connected to a CDP if the data line being read remains less than the nominal data detect voltage of 0.3 V. The portable device detects it is connected to a DCP if the data line being read is greater than the nominal data detect voltage of 0.3 V.

TPS2546 supports CDP mode in system power state S0 when system is completely powered ON, and fully operational. For more details on control pin (CTL1-CTL3) settings to program this state, see [Table 3](#).

8.3.3 Dedicated Charging Port (DCP)

A DCP only provides power but does not support data connection to an upstream port. As shown in following sections, a DCP is identified by the electrical characteristics of the data lines. The TPS2546 emulates DCP in two charging states, namely DCP Forced and DCP Auto as shown in [Figure 37](#). In DCP Forced state the device supports one of the two DCP charging schemes, namely Divider1 or Shorted. In the DCP Auto state, the device charge detection state machine is activated to selectively implement charging schemes involved with the Shorted, Divider1, Divider2, and 1.2-V modes. Shorted DCP mode complies with BC1.2 and Chinese Telecommunications Industry Standard YD/T 1591-2009, while the Divider and 1.2-V modes are employed to charge devices that do not comply with BC1.2 DCP standard.

8.3.3.1 DCP BC1.2 and YD/T 1591-2009

Both standards define that the D+ and D– data lines must be shorted together with a maximum series impedance of 200 Ω. This is shown in [Figure 28](#).

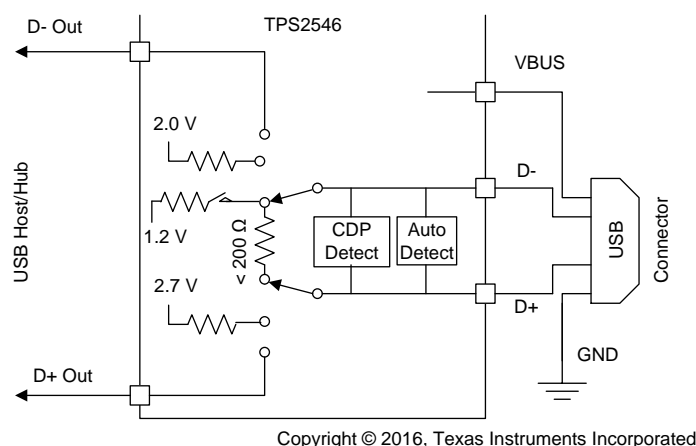

Figure 28. DCP Supporting BC1.2/YD/T 1591-2009

Feature Description (continued)

8.3.3.2 DCP Divider Charging Scheme

There are two Divider charging scheme supported by the device, Divider1 and Divider2 as shown in Figure 29 and Figure 30. In Divider1 charging scheme the device applies 2 V and 2.7 V to D+ and D– data line respectively. This is reversed in Divider2 mode.

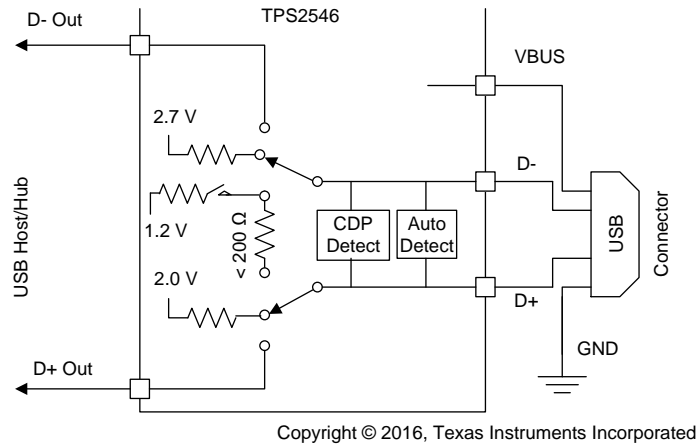

Figure 29. DCP Divider1 Charging Scheme

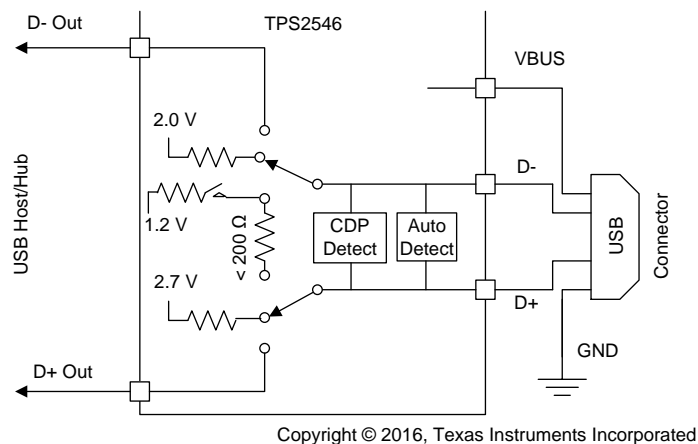

Figure 30. Divider2 Charging Scheme

Feature Description (continued)

8.3.3.3 DCP 1.2-V Charging Scheme

1.2-V charging scheme is used by some handheld devices to enable fast charging at 2 A. TPS2546 supports this scheme in the DCP-Auto mode before the device enters BC1.2 shorted mode. To simulate this charging scheme D+/D– lines are shorted and pulled-up to 1.2 V for fixed duration then device moves to DCP shorted mode as defined in BC1.2 specification. This is shown in [Figure 31](#)

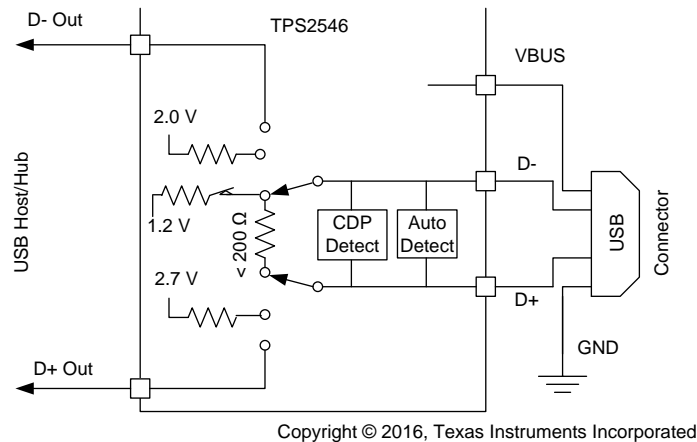

Figure 31. DCP 1.2-V Charging Scheme

8.3.4 Wake on USB Feature (Mouse/Keyboard Wake Feature)

8.3.4.1 USB 2.0 Background Information

The TPS2546 data lines interface with USB 2.0 devices. USB 2.0 defines three types of devices according to data rate. These devices and their characteristics relevant to TPS2546 Wake on USB operation are shown below.

Low-speed USB devices:

- 1.5 Mbps
- Wired mice and keyboards are examples
- No devices that need battery charging
- All signaling performed at 2 V and 0.8 V hi/lo logic levels
- D– high to signal connect and when placed into suspend
- D– high when not transmitting data packets

Full-speed USB devices:

- 12 Mbps
- Wireless mice and keyboards are examples
- Legacy phones and music players are examples
- Some legacy devices that need battery charging
- All signaling performed at 2 V and 0.8 V hi/lo logic levels
- D+ high to signal connect and when placed into suspend
- D+ high when not transmitting data packets

High-speed USB devices:

- 480 Mbps
- Tablets, phones and music players are examples
- Many devices that need battery charging
- Connect and suspend signaling performed at 2 V and 0.8 V hi/lo logic levels
- Data packet signaling performed a logic levels below 0.8 V

Feature Description (continued)

- D+ high to signal connect and when placed into suspend (same as a full-speed device)
- D+ and D– low when not transmitting data packets

8.3.4.2 Wake On USB

Wake on USB is the ability of a wake configured USB device to wake a computer system from its S3 sleep state back to its S0 working state. Wake on USB requires the data lines to be connected to the system USB host before the system is placed into its S3 sleep state, and remain continuously connected until they are used to wake the system.

The TPS2546 supports low-speed and high-speed HID (human interface device like mouse/key board) wake function. There are two scenarios under which wake on mouse are supported by the TPS2546. The specific CTL pin changes that the TPS2546 overrides are shown below. The information is presented as CTL1, CTL2, CTL3. The ILIM_SEL pin plays no role

1. 111 (CDP/SDP2) to 011 (DCP-Auto)
2. 010 (SDP1) to 011 (DCP-Auto)

NOTE

The 110 (SDP1) to 011 (DCP-Auto) transition is not supported. This is done for practical reasons, because the transition involves changes to two CTL pins. Depending on which CTL pin changes first, the device sees either a temporary 111 or 010 command. The 010 command is safe but the 111 command causes an OUT discharge as the TPS2546 instead proceeds to the 111 state.

8.3.4.3 USB Slow-Speed and Full-Speed Device Recognition

TPS2546 is capable of detecting LS or FS device attachment when TPS2546 is in SDP or CDP mode. Per USB specification, when no device is attached, the D+ and D– lines are near ground level. When a low-speed compliant device is attached to the TPS2546 charging port, D– line is pulled high in its idle state (mouse/keyboard not activated). However, when a FS device is attached then the opposite is true in its idle state, that is, D+ is pulled high and D– remains at ground level.

TPS2546 monitors both D+ and D– lines while CTL pin settings are in CDP or SDP mode to detect LS or FS HID device attachment. To support HID sleep wake, TPS2546 must first determine that it is attached to a LS or FS device when system is in S0 power state. TPS2546 does this as described above. While supporting a LS HID wake is straight forward, supporting FS HID requires making a distinction between a FS and a HS device. This is because a high-speed device always presents itself initially as a full speed device (by a 1.5-K pullup resistor on D+). The negotiation for high speed then makes the distinction whereby the 1.5-K pullup resistor gets removed.

TPS2546 handles the distinction between a FS and HS device at connect by memorizing if the D+ line goes low after connect. A HS device after connect always undergoes negotiation for HS, which requires the 1.5-k Ω resistor pullup on D+ to be removed. To memorize a FS device, TPS2546 requires the device to remain connected for at least 60 seconds while the system is in S0 mode, before placing it in sleep or S3 mode.

NOTE

If system is placed in sleep mode earlier than the 60 second window, a FS device may not get recognized and hence could fail to wake system from S3. This requirement does not apply for LS device.

8.3.4.3.1 No CTL Pin Timing Requirement After Wake Event and Transition from S3 to S0

Unlike the TPS2543, there is no CTL pin timing requirement for the TPS2546 when the wake configured USB device wakes the system from S3 back to S0. The TPS2543 requires the CTL pins to transition from the DCP-Auto setting back to the SDP/CDP setting within 64 ms of the attached USB device signaling a wake event (for example, mouse clicked or keyboard key pressed). No such timing condition exists for the TPS2546.

Feature Description (continued)

8.3.5 Load Detect

TPS2546 offers system designers unique power management strategy not available in the industry from similar devices. There are two power management schemes supported by the TPS2546 through the $\overline{\text{STATUS}}$ pin, they are:

- Power Wake (PW)
- Port Power Management (PPM)

Either feature may be implemented in a system depending on power savings goals for the system. In general, Power Wake feature is used mainly in mobile systems, like a notebook, where it is imperative to save battery power when system is in deep sleep (S4/S5) state. Oppositely, Port Power Management feature would be implemented where multiple charging ports are supported in the same system, and system power rating is not capable of supporting high-current charging on multiple ports simultaneously.

8.3.6 Power Wake

The goal of the power wake feature is to save system power when the system is in S4/S5 state. In the S4/S5 state, the system is in deep sleep and typically running off the battery; so every mW in system power savings translates to extending battery life. In this state, the TPS2546 monitors charging current at the OUT pin and provide a mechanism through the $\overline{\text{STATUS}}$ pin to switch out the high-power DC-DC controller and switch in a low power LDO when charging current requirement is < 45 mA (typical). This would be the case when no peripheral device is connected at the charging port or if a device has attained its full battery charge and draws < 45 mA. A power wake flow chart and description is shown in [Figure 32](#).

Feature Description (continued)

- Load being Charged
- TPS2546 is asserting power wake
 - System power is at its full capability
 - Load can charge at high current
 - TPS2546 monitors port to detect when charging load is done charging or removed

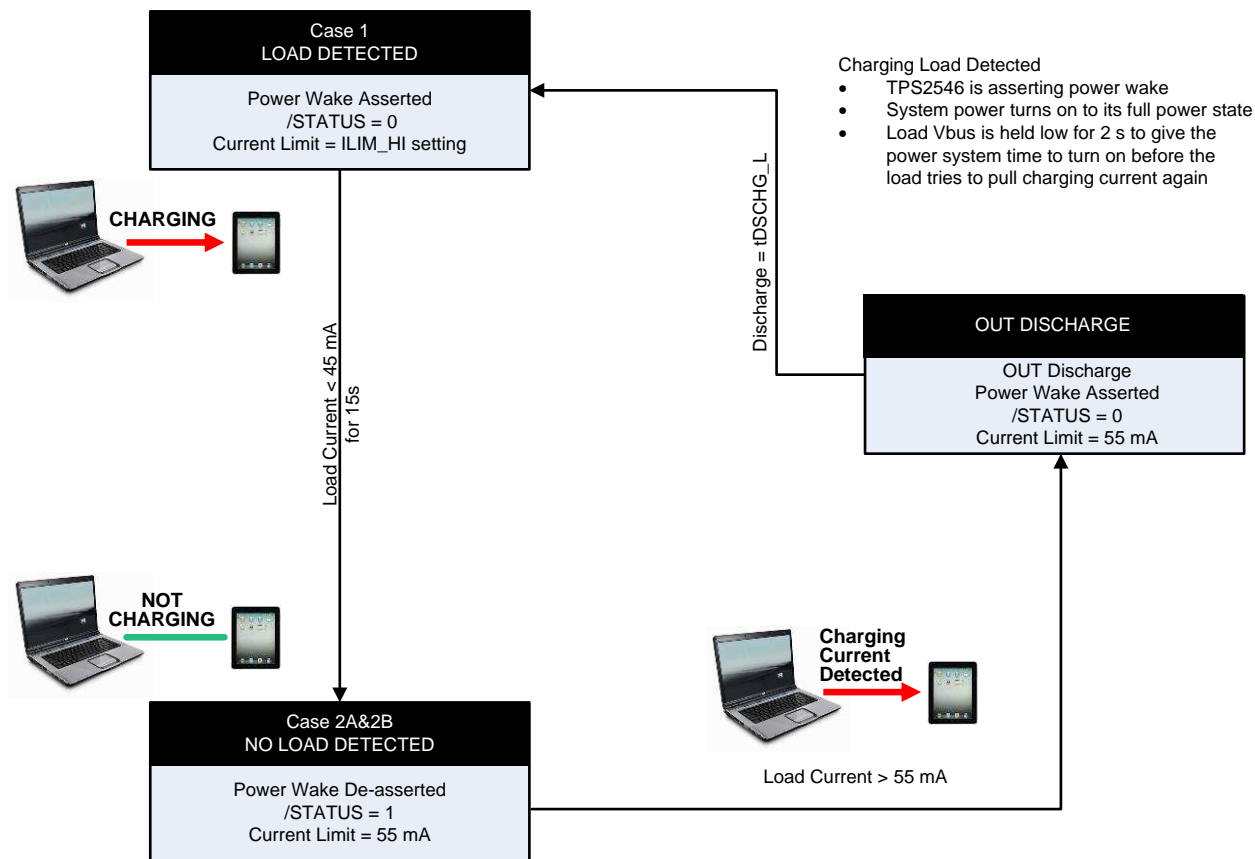

- Charging Load Detected
- TPS2546 is asserting power wake
 - System power turns on to its full power state
 - Load Vbus is held low for 2 s to give the power system time to turn on before the load tries to pull charging current again

- Charging Load Not Detected.
- TPS2546 is not asserting power wake. System power is in a low power state to save energy.
 - TPS2546 monitors port to detect when charging load is attached and tries to charge

Copyright © 2016, Texas Instruments Incorporated

Figure 32. Power Wake Flow Chart

Feature Description (continued)

8.3.6.1 Implementing Power Wake in Notebook System

An implementation of power wake in notebook platforms with the TPS2546 is shown in Figure 33 to Figure 35. Power wake function is used to select between a high-power DC-DC converter, and low-power LDO (100 mA) based on charging requirements. System power saving is achieved when under no charging conditions (the connected device is fully charged or no device is connected) the DC-DC converter is turned off (to save power because it is less efficient in low-power operating region) and the low-power LDO supplies standby power to the charging port.

Power wake is activated in S4/S5 mode (0011 setting, see Table 3), TPS2546 is charging connected device as shown in Figure 33, STATUS is pulled LO (Case 1) which switches-out the LDO and switches-in the DC-DC converter to handle high-current charging.

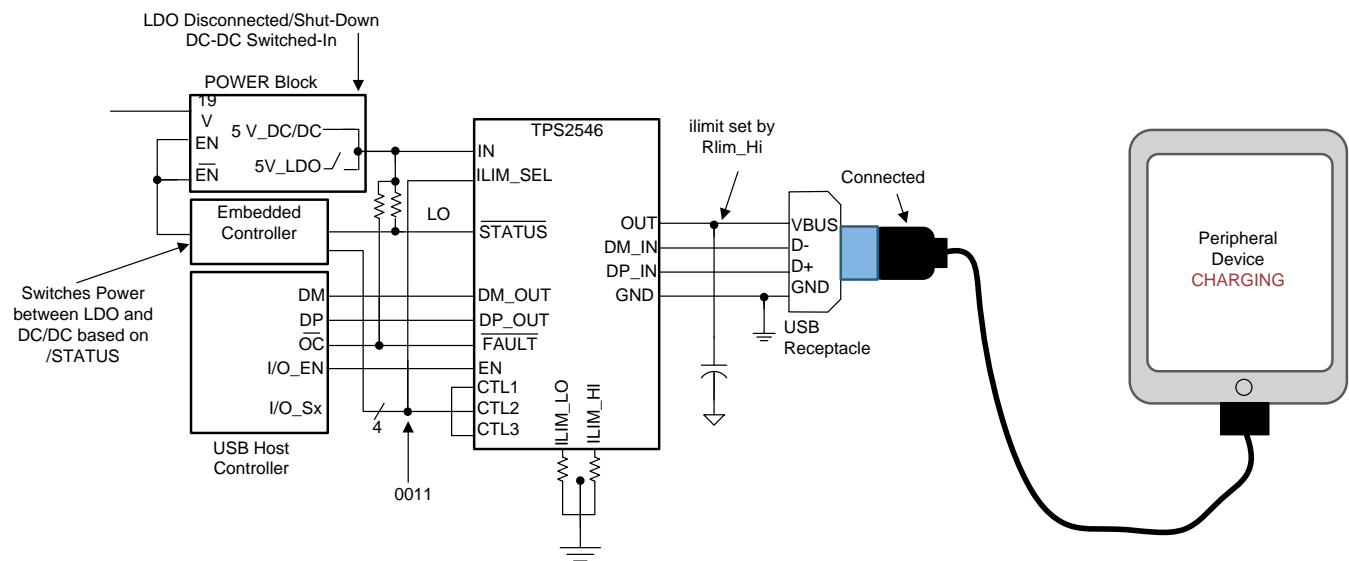

Copyright © 2016, Texas Instruments Incorporated

Figure 33. Case 1: System in S4/S5, Device Charging

As shown in Figure 34 and Figure 35, when connected device is fully charged or gets disconnected from the charging port, the charging current falls. If charging current falls to $< 45 \text{ mA}$ and stays below this threshold for over 15 s, TPS2546 automatically sets a 55-mA internal current limit and STATUS is de-asserted (pulled HI). As shown in Figure 34 and Figure 35. This results in DC-DC converter turning off, and the LDO turning on. Current limit of 55 mA is set to prevent the low-power LDO output voltage from collapsing in case there is a spike in current draw due to device attachment or other activity such as display panel LED turning ON in connected device.

Following Power Wake flow chart (Figure 32) when a device is attached and draws $> 55 \text{ mA}$ of charging current the TPS2546 hits its internal current limit. This triggers the device to assert STATUS (LO), and turn on the DC-DC converter and turn off the LDO. TPS2546 discharges OUT for $> 2 \text{ s}$ (typical), allowing the main power supply to turn on. After the discharge, the device turns back on with current limit set by ILIM_HI (Case 1)

Feature Description (continued)

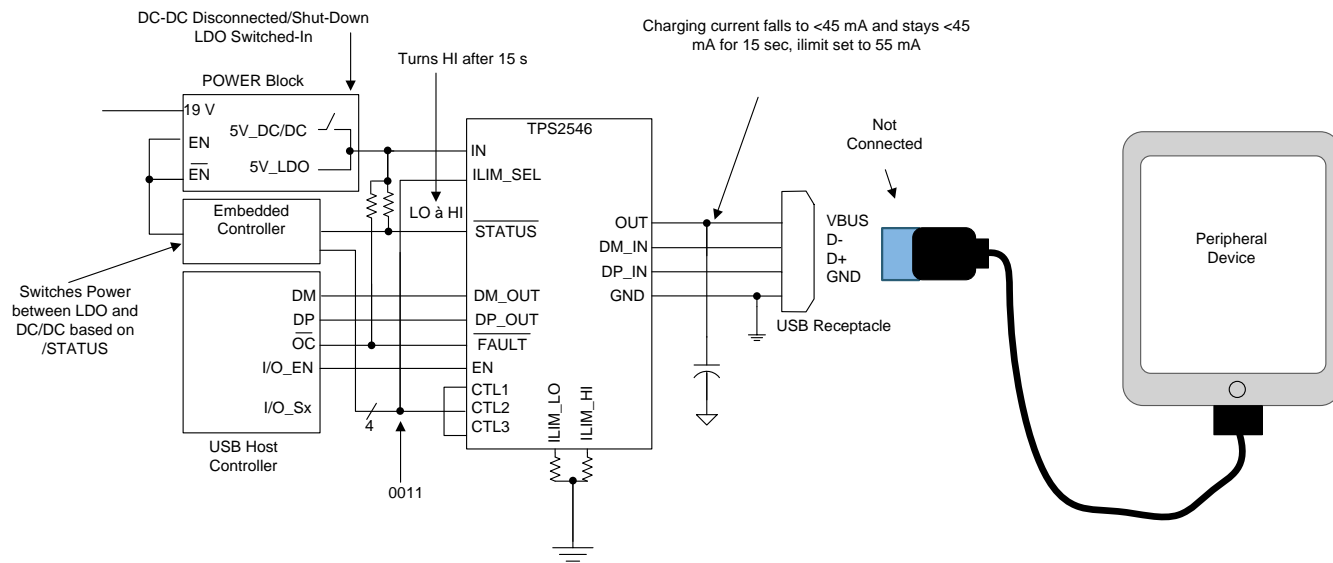

Copyright © 2016, Texas Instruments Incorporated

Figure 34. Case 2A: System in S4/S5, No Device Attached

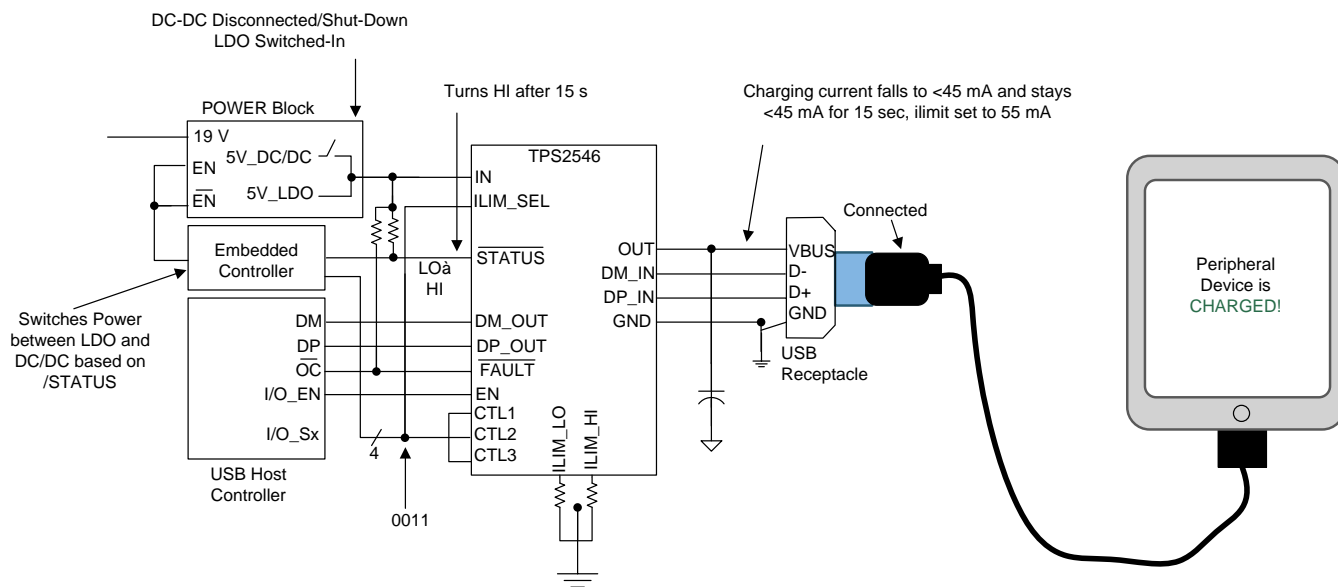

Copyright © 2016, Texas Instruments Incorporated

Figure 35. Case 2B: System in S4/S5, Attached Device Fully Charged

Feature Description (continued)

8.3.7 Port Power Management (PPM)

PPM is the intelligent and dynamic allocation of power for systems that have multiple charging ports but cannot power them all simultaneously. The goals of this feature are:

- Enhance user experience because user does not have to search for charging port
- Ensure the power supply only has to be designed for a reasonable charging load

Initially all ports are allowed to broadcast high-current charging, charging current limit is based on ILIM_HI resistor setting. System monitors STATUS to see when high-current loads are present. Once allowed number of ports assert STATUS, remaining ports are toggled to a non-charging port. Non-charging ports are SDP ports with current limit based on ILIM_LO. TPS2546 allows for a system to toggle between charging and non-charging ports either with an OUT discharge or without an OUT discharge.

8.3.7.1 Benefits of PPM

- Delivers better user experience
- Prevents overloading of system's power supply
- Allows for dynamic power limits based on system state
- Allows every port to potentially be a high-power charging port
- Allows for smaller power supply capacity because the loading is controlled

8.3.7.2 PPM Details

All ports are allowed to broadcast high-current charging – CDP or DCP. Current limit is based on ILIM_HI and system monitors STATUS pin to see when high-current loads are present. Once allowed number of ports assert STATUS, remaining ports are toggled to a SDP non-charging port. SDP current limit is based on ILIM_LO setting. SDP ports are automatically toggled back to CDP or DCP mode when a charging port de-asserts STATUS.

Based on CTL settings there is a provision for a port to toggle between charging and non-charging ports either with a Vbus discharge or without a Vbus discharge. For example when a port is in SDP2 mode (1110) and its ILIM_SEL pin is toggled to 1 due to another port releasing its high-current requirements. The SDP2 port automatically reverts to CDP mode (1111) without a discharge event. This is desirable if this port was connected to a media device where it was syncing data from the SDP2 port; a discharge event would disrupt the syncing activity on the port and cause user confusion.

STATUS trip point is based on the programmable ILIM_LO current limit set point. This does not mean STATUS is a current limit – the port itself is using the ILIM_HI current limit. Since ILIM_LO defines the current limit for a SDP port, it works well to use the ILIM_LO value to define a high-current load. STATUS asserts in CDP and DCP when load current is above $ILIM_LO + 60\text{ mA}$ for 200 ms. STATUS also asserts in CDP when an attached device does a BC1.2 primary detection. STATUS de-asserts in CDP and DCP when the load current is below $ILIM_LO + 10\text{ mA}$ for 3 s.

8.3.7.3 Implementing PPM in a System with Two Charging Ports

Figure 36 shows implementation of two charging ports, each with its own TPS2546. In this example 5-V power supply for the two charging ports is rated at < 3 A or < 15 W maximum. Both devices have R_{LIM} chosen to correspond to the low (0.9 A) and high (1.5 A) current limit setting for the port. In this implementation the system can support only one of the two ports at 1.5-A charging current while the other port is set to SDP mode and I_{LIMIT} corresponding to 0.9 A.

Feature Description (continued)

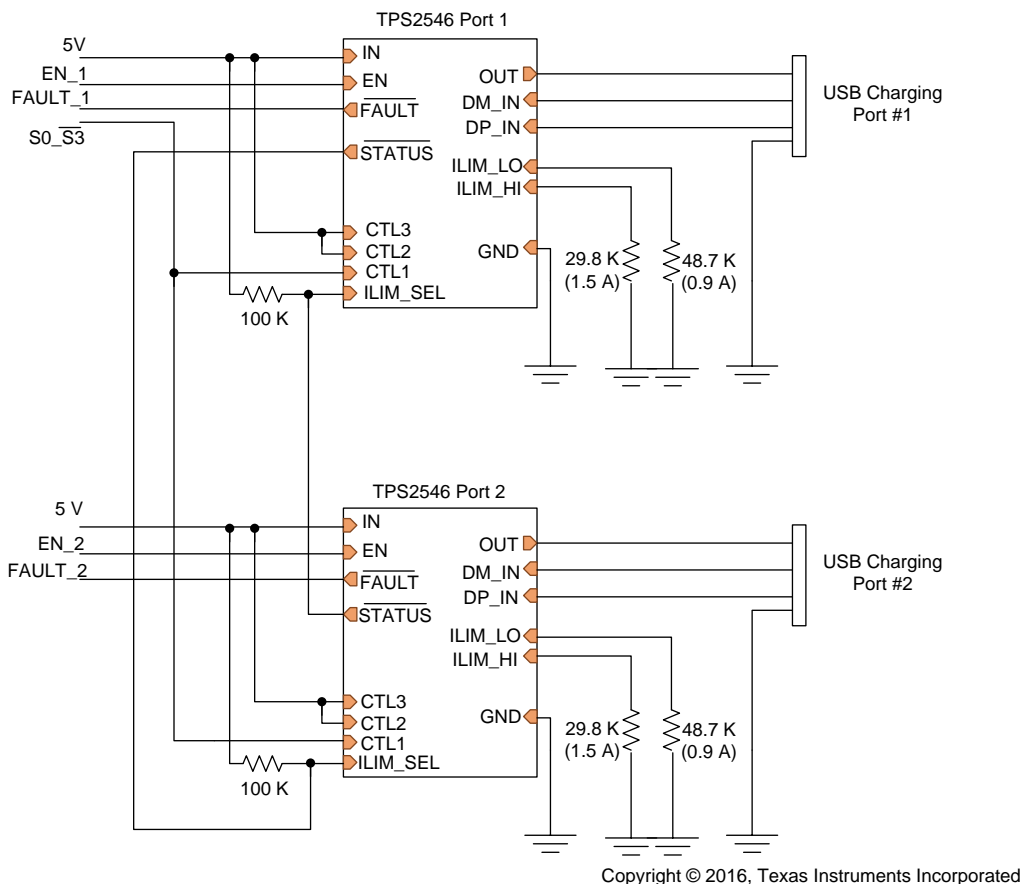

Figure 36. Implementing Port Power Management in a System Supporting Two Charging Ports

8.3.8 Overcurrent Protection

When an overcurrent condition is detected, the device maintains a constant output current and reduces the output voltage accordingly. Two possible overload conditions can occur. In the first condition, the output has been shorted before the device is enabled or before V_{IN} has been applied. The TPS2546 senses the short and immediately switches into a constant-current output. In the second condition, a short or an overload occurs while the device is enabled. At the instant the overload occurs, high currents may flow for nominally one to two microseconds before the current-limit circuit can react. The device operates in constant-current mode after the current-limit circuit has responded. Complete shutdown occurs only if the fault is present long enough to activate thermal limiting. The device remains off until the junction temperature cools approximately 20°C and then re-starts. The device continues to cycle on/off until the overcurrent condition is removed.

8.3.9 FAULT Response

The $\overline{\text{FAULT}}$ open-drain output is asserted (active low) during an overtemperature or current limit condition. The output remains asserted until the fault condition is removed. The TPS2546 is designed to eliminate false $\overline{\text{FAULT}}$ reporting by using an internal de-glitch circuit for current limit conditions without the need for external circuitry. This ensures that $\overline{\text{FAULT}}$ is not accidentally asserted due to normal operation such as starting into a heavy capacitive load. Overtemperature conditions are not de-glitched and assert the $\overline{\text{FAULT}}$ signal immediately.

8.3.10 Undervoltage Lockout (UVLO)

The undervoltage lockout (UVLO) circuit disables the power switch until the input voltage reaches the UVLO turnon threshold. Built-in hysteresis prevents unwanted oscillations on the output due to input voltage drop from large current surges.

Feature Description (continued)

8.3.11 Thermal Sense

The TPS2546 protects itself with two independent thermal sensing circuits that monitor the operating temperature of the power distribution switch and disables operation if the temperature exceeds recommended operating conditions. The device operates in constant-current mode during an overcurrent condition, which increases the voltage drop across power switch. The power dissipation in the package is proportional to the voltage drop across the power switch, so the junction temperature rises during an overcurrent condition. The first thermal sensor turns off the power switch when the die temperature exceeds 135°C and the part is in current limit. The second thermal sensor turns off the power switch when the die temperature exceeds 155°C regardless of whether the power switch is in current limit. Hysteresis is built into both thermal sensors, and the switch turns on after the device has cooled by approximately 20°C. The switch continues to cycle off and on until the fault is removed. The open-drain false reporting output FAULT is asserted (active low) during an overtemperature shutdown condition.

8.4 Device Functional Modes

Table 1 shows the differences between these ports.

Table 1. Operating Modes

PORT TYPE	SUPPORT USB 2.0 COMMUNICATION	MAXIMUM ALLOWABLE CURRENT DRAW BY PORTABLE DEVICE (A)
SDP (USB 2.0)	Yes	0.5
SDP (USB 3.0)	Yes	0.9
CDP	Yes	1.5
DCP	No	1.5

8.4.1 DCP Auto Mode

As mentioned above the TPS2546 integrates an auto-detect state machine that supports all the above DCP charging schemes. It starts in Divider1 scheme, however if a BC1.2 or YD/T 1591-2009 compliant device is attached, the TPS2546 responds by discharging OUT, turning back on the power switch and operating in 1.2 V mode briefly and then moving to BC1.2 DCP mode. It then stays in that mode until the device releases the data line, in which case it goes back to Divider1 scheme. When a Divider1 compliant device is attached the TPS2546 stays in Divider1 state.

Also, the TPS2546 automatically switches between the Divider1 and Divider2 schemes based on charging current drawn by the connected device. Initially the device sets the data lines to Divider1 scheme. If charging current of > 750 mA is measured by the TPS2546 it switches to Divider2 scheme and test to see if the peripheral device still charges at a high current. If it does then it stays in Divider2 scheme otherwise it reverts to Divider1 scheme.

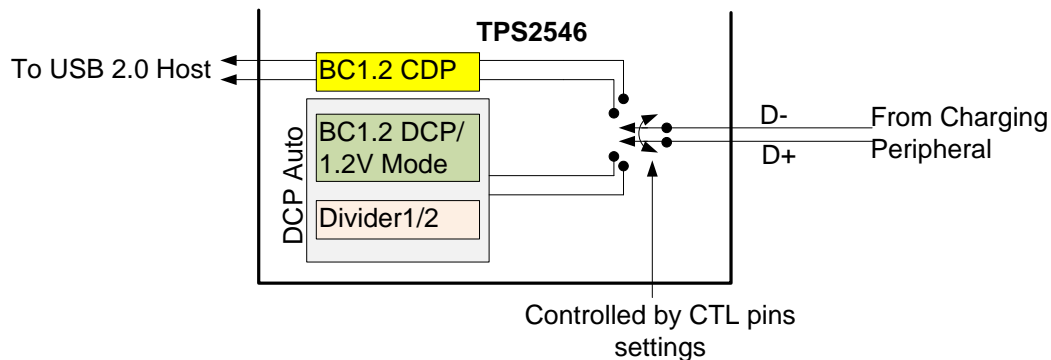

Figure 37. DCP Auto Mode

8.4.2 DCP Forced Shorted / DCP Forced Divider1

In this mode the device is permanently set to one of the DCP schemes (BC1.2/ YD/T 1591-2009 or Divider1) as commanded by its control pin setting per [Table 3](#).

8.4.3 High-Bandwidth Data Line Switch

The TPS2546 passes the D+ and D– data lines through the device to enable monitoring and handshaking while supporting charging operation. A wide bandwidth signal switch is used, allowing data to pass through the device without corrupting signal integrity. The data line switches are turned on in any of CDP or SDP operating modes. The EN input also needs to be at logic High for the data line switches to be enabled.

NOTE

- While in CDP mode, the data switches are ON even while CDP handshaking is occurring
- The data line switches are OFF if EN or all CTL pins are held low, or if in DCP mode. They are not automatically turned off if the power switch (IN to OUT) is in current limit
- The data switches are for USB 2.0 differential pair only. In the case of a USB 3.0 host, the super speed differential pairs must be routed directly to the USB connector without passing through the TPS2546
- Data switches are OFF during OUT (VBUS) discharge

[Table 2](#) can be used as an aid to program the TPS2546 per system states however not restricted to below settings only.

Table 2. Control Pin Settings Matched to System Power States

SYSTEM GLOBAL POWER STATE	TPS2546 CHARGING MODE	CTL1	CTL2	CTL3	ILIM_SEL	CURRENT LIMIT SETTING
S0	SDP1	1	1	0	1 or 0	ILIM_HI / ILIM_LO
S0	SDP2, no discharge to / from CDP	1	1	1	0	ILIM_LO
S0	CDP, load detection with ILIM_LO + 60-mA thresholds or if a BC1.2 primary detection occurs	1	1	1	1	ILIM_HI
S4/S5	Auto mode, load detection with power wake thresholds	0	0	1	1	ILIM_HI
S3/S4/S5	Auto mode, no load detection	0	0	1	0	ILIM_HI
S3	Auto mode, keyboard/mouse wake up, load detection with ILIM_LO + 60 mA thresholds	0	1	1	1	ILIM_HI
S3	Auto mode, keyboard/mouse wake-up, no load detection	0	1	1	0	ILIM_HI
S3	SDP1, keyboard/mouse wake-up	0	1	0	1 or 0	ILIM_HI / ILIM_LO

8.4.4 Device Truth Table (TT)

Device TT lists all valid bias combinations for the three control pins CTL1-3 and ILIM_SEL pin and their corresponding charging mode. It is important to note that the TT purposely omits matching charging modes of the TPS2546 with global power states (S0-S5) as device is agnostic to system power states. The TPS2546 monitors CTL inputs and transitions to the charging state it is commanded to go to (except when LS/FS HID device is detected). For example, if sleep charging is desired when system is in standby or hibernate state then the user must set TPS2546 CTL pins to correspond to DCP_Auto charging mode as shown in the below table. When the system resumes operation mode set the control pins to correspond to SDP or CDP mode, as seen in [Table 3](#).

Table 3. Truth Table

CTL1	CTL2	CTL3	ILIM_SEL	MODE	CURRENT LIMIT SETTING	STATUS OUTPUT (ACTIVE LOW)	COMMENT
0	0	0	0	Discharge	NA	OFF	OUT held low.
0	0	0	1	Discharge	NA	OFF	
0	0	1	0	DCP_Auto	ILIM_HI	OFF	Data lines disconnected.
0	0	1	1	DCP_Auto	I_{OS_PW} & ILIM_HI ⁽¹⁾	DCP load present ⁽²⁾	Data lines disconnected and load detect function active.
0	1	0	0	SDP1	ILIM_LO	OFF	Data lines connected.
0	1	0	1	SDP1	ILIM_HI	OFF	
0	1	1	0	DCP_Auto	ILIM_HI	OFF	Data lines disconnected.
0	1	1	1	DCP_Auto	ILIM_HI	DCP load present ⁽³⁾	Data lines disconnected and load detect function active.
1	0	0	0	DCP_Shorted	ILIM_LO	OFF	Device forced to stay in DCP BC1.2 charging mode.
1	0	0	1	DCP_Shorted	ILIM_HI	OFF	
1	0	1	0	DCP / Divider1	ILIM_LO	OFF	Device forced to stay in DCP divider1 charging mode.
1	0	1	1	DCP / Divider1	ILIM_HI	OFF	
1	1	0	0	SDP1	ILIM_LO	OFF	Data lines connected.
1	1	0	1	SDP1	ILIM_HI	OFF	
1	1	1	0	SDP2 ⁽⁴⁾	ILIM_LO	OFF	
1	1	1	1	CDP ⁽⁴⁾	ILIM_HI	CDP load present ⁽⁵⁾	

(1) TPS2546 : Current limit (I_{OS}) is automatically switched between I_{OS_PW} and the value set by ILIM_HI according to the Load Detect – Power Wake functionality.

(2) DCP Load present governed by the Load Detection – Power Wake limits.

(3) DCP Load present governed by the Load Detection – Non Power Wake limits.

(4) No OUT discharge when changing between 1111 and 1110.

(5) CDP Load present governed by the Load Detection – Non Power Wake limits and BC1.2 primary detection.

9 Application and Implementation

NOTE

Information in the following applications sections is not part of the TI component specification, and TI does not warrant its accuracy or completeness. TI's customers are responsible for determining suitability of components for their purposes. Customers must validate and test their design implementation to confirm system functionality.

9.1 Application Information

Power-on-reset (POR) holds device in initial state while output is held in discharge mode. Any POR event returns the device to initial state. After POR clears, device goes to the next state depending on the CTL lines as shown in Figure 38.

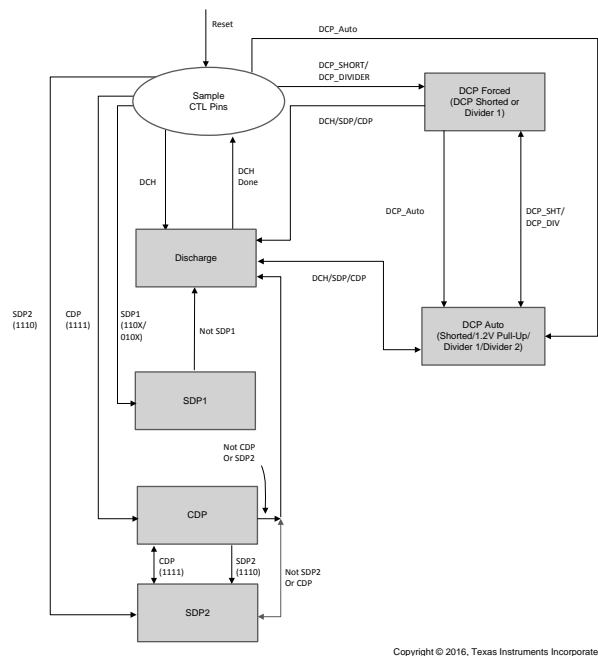

Figure 38. TPS2546 Charging States

9.1.1 Output Discharge

To allow a charging port to renegotiate current with a portable device, the TPS2546 device uses the OUT discharge function. The device proceeds by turning off the power switch while discharging OUT. The device then turns on the power switch again to reassert the OUT voltage. This discharge function is automatically applied, as shown in Figure 26. There are two discharge times, t_{DCHG_L} and t_{DCHG_S} . t_{DCHG_L} is from SDP1/SDP2/CDP to DCP_Auto, and t_{DCHG_S} is from DCP_Auto to SDP1/SDP2/CDP.

9.1.2 CDP/SDP Auto Switch

TPS2546 is equipped with a CDP/SDP auto-switch feature to support some popular phones in the market that are not compliant to the BC1.2 specification, as they fail to establish data connection in CDP mode. These phones use primary detection (used to distinguish between an SDP and different types of Charging Ports) to only identify ports as SDP (data / no charge) or DCP (no data / charge). They do not recognize CDP (data /charge) ports. When connected to a CDP port, these phones classify the port as a DCP and only charges. Since charging ports are configured as CDP when the computer is in S0, users do not get the expected data connection.

Application Information (continued)

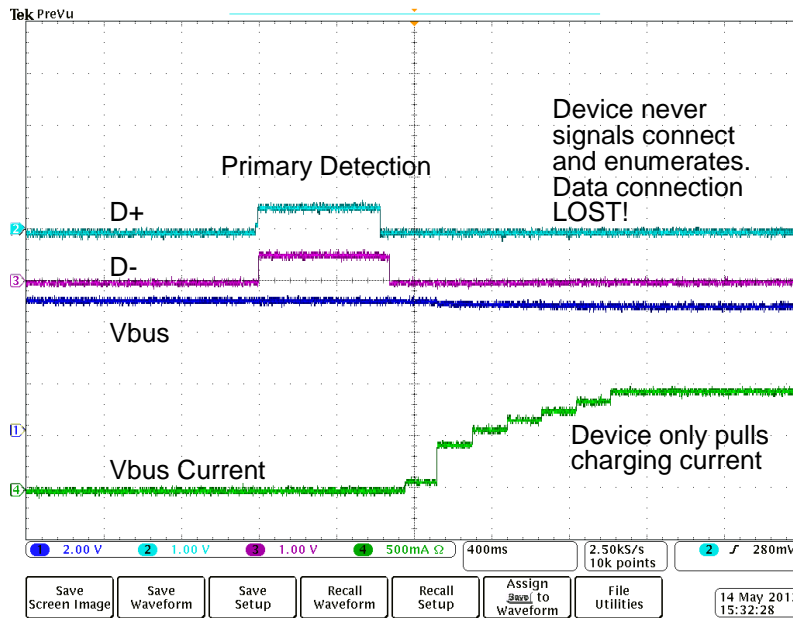
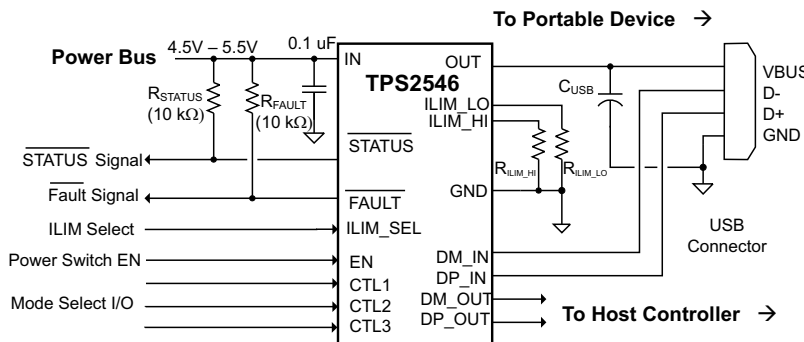

Figure 39. CDP/SDP Auto

To fix this problem, TPS2546 employs a CDP/SDP Auto Switch scheme to ensure these BC1.2 non-compliant phones establishes data connection by following below steps:

- The TPS2546 determines when a non-compliant phone has wrongly classified a CDP port as a DCP port and has not made a data connection
- The TPS2546 then automatically does a OUT (VBUS) discharge and reconfigure the port as an SDP
- This allows the phone to discover it is now connected to an SDP and establish a data connection
- The TPS2546 then switches automatically back to CDP without doing an OUT (VBUS) discharge
- The phone continues to operate like it is connected to a SDP because OUT (VBUS) was not interrupted
- The port is now ready in CDP if a new device is attached

9.2 Typical Application



Copyright © 2016, Texas Instruments Incorporated

Figure 40. Typical Application Schematic USB Port Charging

Typical Application (continued)

9.2.1 Design Requirements

For this design example, use the parameters listed in [Table 4](#).

Table 4. Design Parameters

DESIGN PARAMETER	EXAMPLE VALUE
Input voltage, $V_{(IN)}$	5 V
Output voltage, $V_{(DC)}$	5 V
Maximum continuous output current, $I_{(OUT)}$	2.5 A
Current limit, $I_{(LIM_LO)}$ at $R_{ILIM_LO} = 80.6 \text{ k}\Omega$	0.625 A
Current Limit, $I_{(LIM_HI)}$ at $R_{ILIM_HI} = 16.9 \text{ k}\Omega$	2.97 A

9.2.2 Detailed Design Procedure

9.2.2.1 Current-Limit Settings

The TPS2546 has two independent current limit settings that are each programmed externally with a resistor. The $ILIM_HI$ setting is programmed with R_{ILIM_HI} connected between $ILIM_HI$ and GND. The $ILIM_LO$ setting is programmed with R_{ILIM_LO} connected between $ILIM_LO$ and GND. Consult the Device Truth Table ([Table 3](#)) to see when each current limit is used. Both settings have the same relation between the current limit and the programming resistor.

R_{ILIM_LO} is optional and the $ILIM_LO$ pin may be left unconnected if the following conditions are met:

1. $ILIM_SEL$ is always set high
2. Load Detection - Port Power Management is not used

[Equation 1](#) programs the typical current limit:

$$I_{OS_typ}(\text{mA}) = \frac{50,250}{R_{ILIM_XX}(\text{k}\Omega)} \quad (1)$$

R_{ILIM_XX} corresponds to either R_{ILIM_HI} or R_{ILIM_LO} as appropriate.

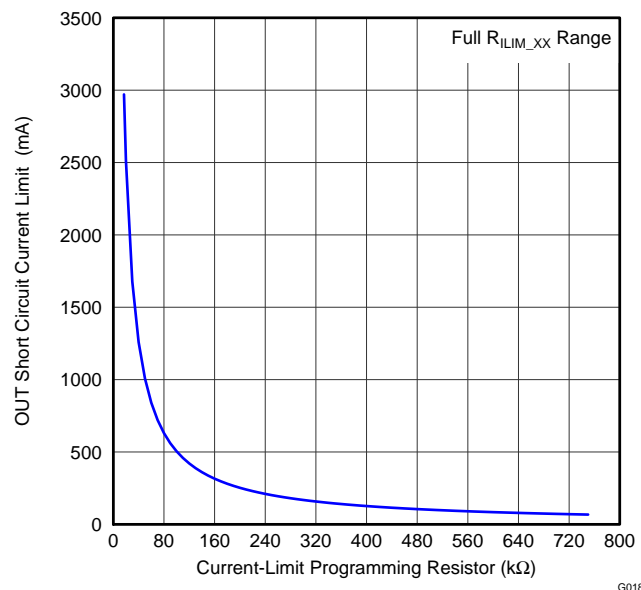

Figure 41. Typical Current Limit Setting vs Programming Resistor

Many applications require that the current limit meet specific tolerance limits. When designing to these tolerance limits, both the tolerance of the TPS2546 current limit and the tolerance of the external programming resistor must be taken into account. The following equations approximate the TPS2546 minimum and maximum current limits to within a few mA, and are appropriate for design purposes. The equations do not constitute part of Texas Instrument's published device specifications for purposes of Texas Instrument's product warranty. These equations assume an ideal - no variation - external programming resistor. To take resistor tolerance into account, first determine the minimum and maximum resistor values based on its tolerance specifications, and use these values in the equations. Because of the inverse relation between the current limit and the programming resistor, use the maximum resistor value in the Equation 2 and the minimum resistor value in the Equation 3.

$$I_{OS_min} (mA) = \frac{45,271}{(R_{ILIM_XX} (k\Omega))^{0.98437}} - 30 \tag{2}$$

$$I_{OS_max} (mA) = \frac{55,325}{(R_{ILIM_XX} (k\Omega))^{1.0139}} + 30 \tag{3}$$

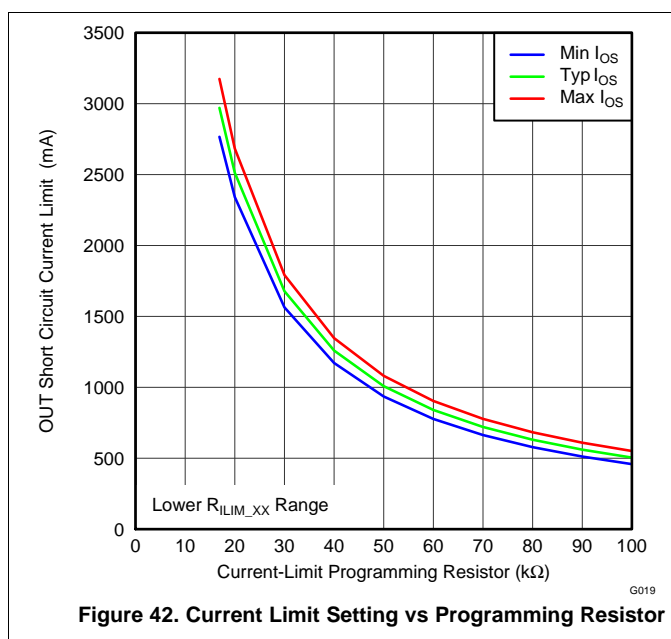

Figure 42. Current Limit Setting vs Programming Resistor

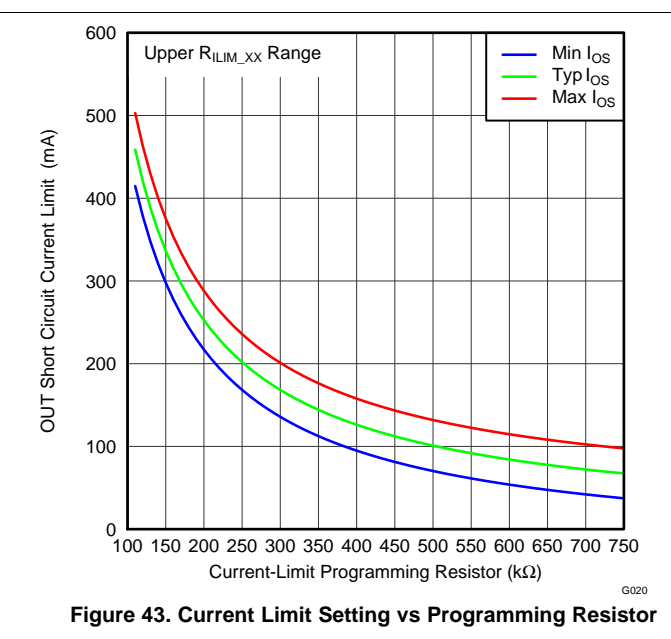
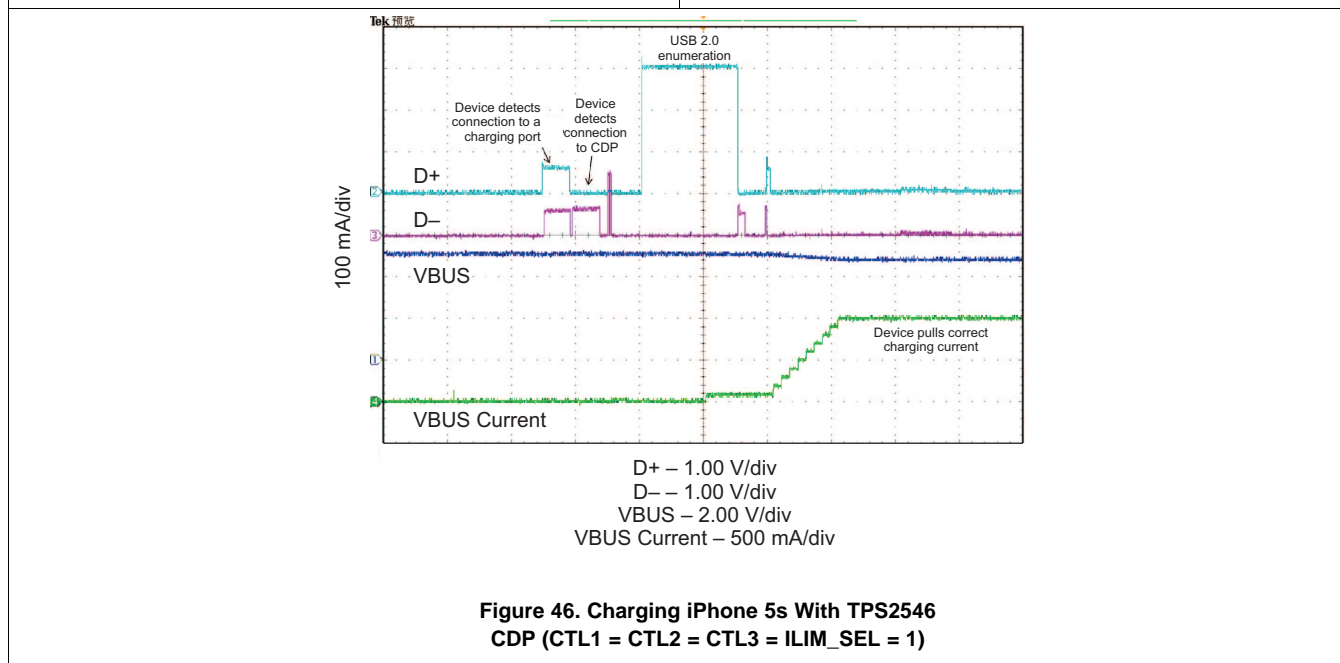
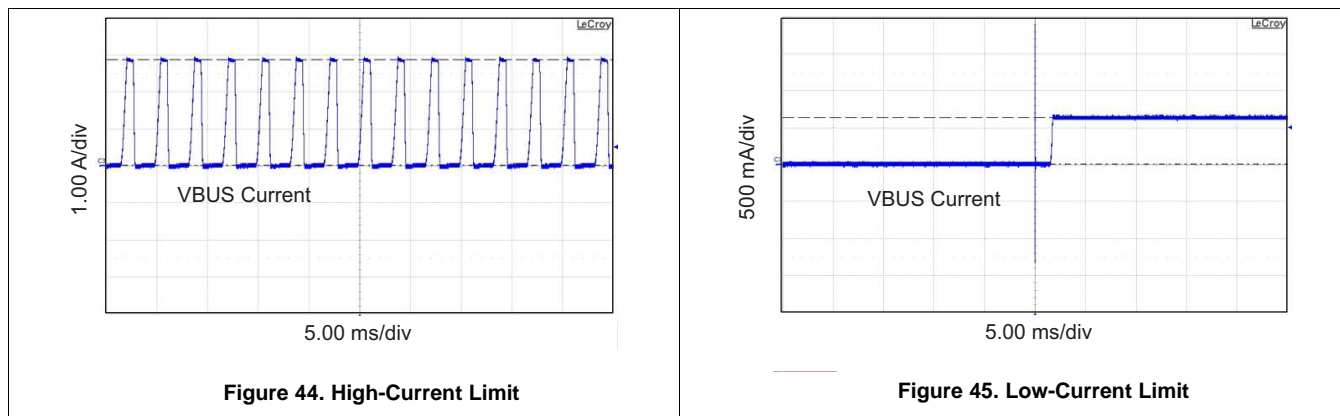

Figure 43. Current Limit Setting vs Programming Resistor

The traces routing the R_{ILIM_XX} resistors must be a sufficiently low resistance as to not affect the current-limit accuracy. The ground connection for the R_{ILIM_XX} resistors is also very important. The resistors need to reference back to the TPS2546 GND pin. Follow normal board layout practices to ensure that current flow from other parts of the board does not impact the ground potential between the resistors and the TPS2546 GND pin.

9.2.3 Application Curves



10 Power Supply Recommendations

The TPS2546 device is designed for a supply-voltage range of $4.5\text{ V} \leq V_{IN} \leq 5.5\text{ V}$. If the input supply is located more than a few inches from the device, an input ceramic bypass capacitor higher than $0.1\text{ }\mu\text{F}$ is recommended. In order to avoid drops in voltage during overcurrent and short-circuit conditions, choose a power supply rated higher than the TPS2546 current-limit setting.

11 Layout

11.1 Layout Guidelines

For the trace routing of DP_IN, DM_IN, DP_OUT, and DM_OUT: route these traces as micro-strips with nominal differential impedance of $90\text{ }\Omega$. Minimize the use of vias in the high-speed data lines. Keep the reference GND plane devoid from cuts or splits above the differential pairs to prevent impedance discontinuities. For more information, see the *High-Speed USB Platform Design Guidelines* from Intel.

The trace routing from the upstream regulator to the TPS2546 IN pin must as short as possible to reduce the voltage drop and parasitic inductance.





Layout Guidelines (continued)

In order to meet IEC61000-4-2 level 4 ESD, external circuitry is required. Refer to the guidelines provided in the [Related Documentation](#) section.

The traces routing from the RILIM_HI and RILIM_LO resistors to the device must be as short as possible to reduce parasitic effects on the current-limit accuracy.

The thermal pad must be directly connected to the PCB ground plane using wide and short copper trace.

11.2 Layout Example

-  Top Layer Signal Trace
-  Top Layer Signal Ground Plane
-  Bottom Layer Signal Trace
-  Via to Bottom layer Signal Ground Plane
-  Via to Bottom layer Signal

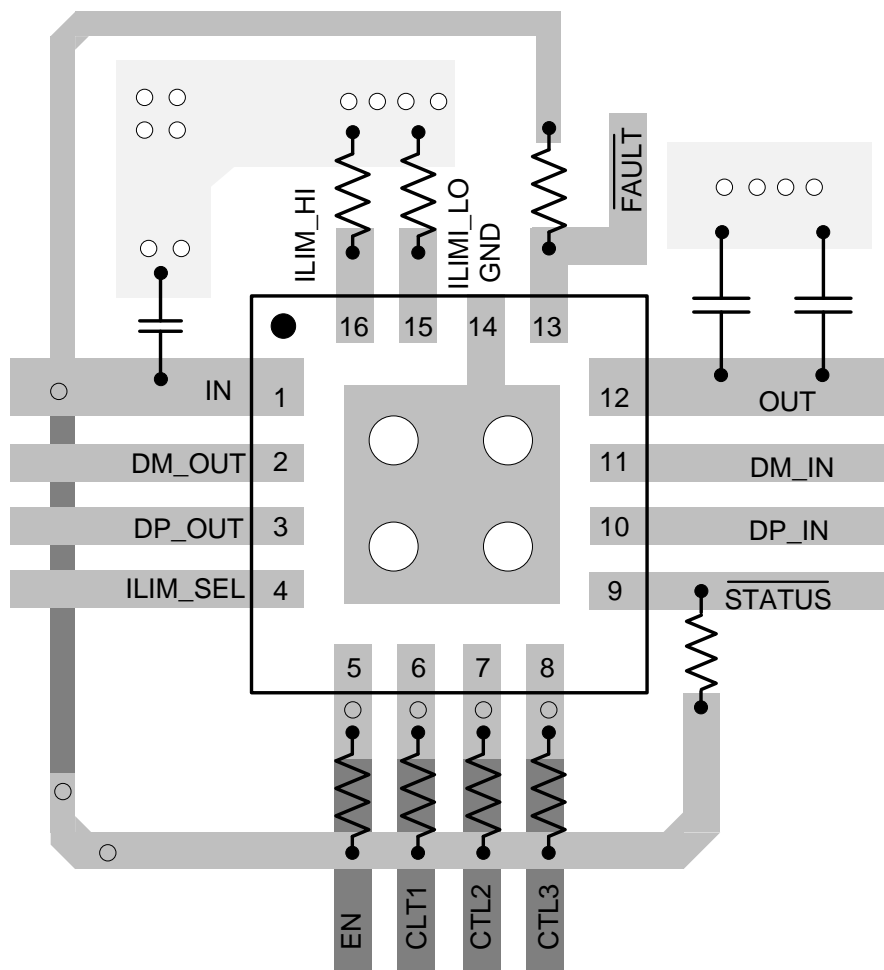

Figure 47. Layout Recommendation

12 Device and Documentation Support

12.1 Documentation Support

12.1.1 Related Documentation

For related documentation see:

Effective System ESD Protection for TPS254x USB Charging Port Controllers, [SLVA796](#).

High Speed USB Platform Design Guidelines, Intel (www.usb.org/developers/docs/hs_usb_pdg_r1_0.pdf)

USB 2.0 Specifications (www.usb.org/developers/docs/usb20_docs/#usb20spec)

BC1.2 Battery Charging Specification (kinetis.pl/sites/default/files/BC1.2_FINAL.pdf)

12.2 Receiving Notification of Documentation Updates

To receive notification of documentation updates, navigate to the device product folder on ti.com. In the upper right corner, click on *Alert me* to register and receive a weekly digest of any product information that has changed. For change details, review the revision history included in any revised document.

12.3 Community Resources

The following links connect to TI community resources. Linked contents are provided "AS IS" by the respective contributors. They do not constitute TI specifications and do not necessarily reflect TI's views; see TI's [Terms of Use](#).

TI E2E™ Online Community *TI's Engineer-to-Engineer (E2E) Community*. Created to foster collaboration among engineers. At e2e.ti.com, you can ask questions, share knowledge, explore ideas and help solve problems with fellow engineers.

Design Support *TI's Design Support* Quickly find helpful E2E forums along with design support tools and contact information for technical support.

12.4 Trademarks

E2E is a trademark of Texas Instruments.
All other trademarks are the property of their respective owners.

12.5 Electrostatic Discharge Caution



These devices have limited built-in ESD protection. The leads should be shorted together or the device placed in conductive foam during storage or handling to prevent electrostatic damage to the MOS gates.

12.6 Glossary



[SLYZ022](#) — *TI Glossary*.

This glossary lists and explains terms, acronyms, and definitions.

13 Mechanical, Packaging, and Orderable Information

The following pages include mechanical, packaging, and orderable information. This information is the most current data available for the designated devices. This data is subject to change without notice and revision of this document. For browser-based versions of this data sheet, refer to the left-hand navigation.

PACKAGING INFORMATION

Orderable Device	Status (1)	Package Type	Package Drawing	Pins	Package Qty	Eco Plan (2)	Lead finish/ Ball material (6)	MSL Peak Temp (3)	Op Temp (°C)	Device Marking (4/5)	Samples
TPS2546RTER	ACTIVE	WQFN	RTE	16	3000	RoHS & Green	NIPDAU	Level-2-260C-1 YEAR	-40 to 125	2546	
TPS2546RTET	ACTIVE	WQFN	RTE	16	250	RoHS & Green	NIPDAU	Level-2-260C-1 YEAR	-40 to 125	2546	

(1) The marketing status values are defined as follows:

ACTIVE: Product device recommended for new designs.

LIFEBUY: TI has announced that the device will be discontinued, and a lifetime-buy period is in effect.

NRND: Not recommended for new designs. Device is in production to support existing customers, but TI does not recommend using this part in a new design.

PREVIEW: Device has been announced but is not in production. Samples may or may not be available.

OBSOLETE: TI has discontinued the production of the device.

(2) **RoHS:** TI defines "RoHS" to mean semiconductor products that are compliant with the current EU RoHS requirements for all 10 RoHS substances, including the requirement that RoHS substance do not exceed 0.1% by weight in homogeneous materials. Where designed to be soldered at high temperatures, "RoHS" products are suitable for use in specified lead-free processes. TI may reference these types of products as "Pb-Free".

RoHS Exempt: TI defines "RoHS Exempt" to mean products that contain lead but are compliant with EU RoHS pursuant to a specific EU RoHS exemption.

Green: TI defines "Green" to mean the content of Chlorine (Cl) and Bromine (Br) based flame retardants meet JS709B low halogen requirements of <=1000ppm threshold. Antimony trioxide based flame retardants must also meet the <=1000ppm threshold requirement.

(3) MSL, Peak Temp. - The Moisture Sensitivity Level rating according to the JEDEC industry standard classifications, and peak solder temperature.

(4) There may be additional marking, which relates to the logo, the lot trace code information, or the environmental category on the device.

(5) Multiple Device Markings will be inside parentheses. Only one Device Marking contained in parentheses and separated by a "~" will appear on a device. If a line is indented then it is a continuation of the previous line and the two combined represent the entire Device Marking for that device.

(6) Lead finish/Ball material - Orderable Devices may have multiple material finish options. Finish options are separated by a vertical ruled line. Lead finish/Ball material values may wrap to two lines if the finish value exceeds the maximum column width.

Important Information and Disclaimer:The information provided on this page represents TI's knowledge and belief as of the date that it is provided. TI bases its knowledge and belief on information provided by third parties, and makes no representation or warranty as to the accuracy of such information. Efforts are underway to better integrate information from third parties. TI has taken and continues to take reasonable steps to provide representative and accurate information but may not have conducted destructive testing or chemical analysis on incoming materials and chemicals. TI and TI suppliers consider certain information to be proprietary, and thus CAS numbers and other limited information may not be available for release.

In no event shall TI's liability arising out of such information exceed the total purchase price of the TI part(s) at issue in this document sold by TI to Customer on an annual basis.

OTHER QUALIFIED VERSIONS OF TPS2546 :

- Automotive: [TPS2546-Q1](#)

NOTE: Qualified Version Definitions:

- Automotive - Q100 devices qualified for high-reliability automotive applications targeting zero defects

TAPE AND REEL INFORMATION

QUADRANT ASSIGNMENTS FOR PIN 1 ORIENTATION IN TAPE

*All dimensions are nominal

Device	Package Type	Package Drawing	Pins	SPQ	Reel Diameter (mm)	Reel Width W1 (mm)	A0 (mm)	B0 (mm)	K0 (mm)	P1 (mm)	W (mm)	Pin1 Quadrant
TPS2546RTER	WQFN	RTE	16	3000	330.0	12.4	3.3	3.3	1.1	8.0	12.0	Q2
TPS2546RTET	WQFN	RTE	16	250	180.0	12.4	3.3	3.3	1.1	8.0	12.0	Q2

TAPE AND REEL BOX DIMENSIONS

*All dimensions are nominal

Device	Package Type	Package Drawing	Pins	SPQ	Length (mm)	Width (mm)	Height (mm)
TPS2546RTER	WQFN	RTE	16	3000	346.0	346.0	33.0
TPS2546RTET	WQFN	RTE	16	250	210.0	185.0	35.0

GENERIC PACKAGE VIEW

RTE 16

WQFN - 0.8 mm max height

3 x 3, 0.5 mm pitch

PLASTIC QUAD FLATPACK - NO LEAD

This image is a representation of the package family, actual package may vary.
Refer to the product data sheet for package details.

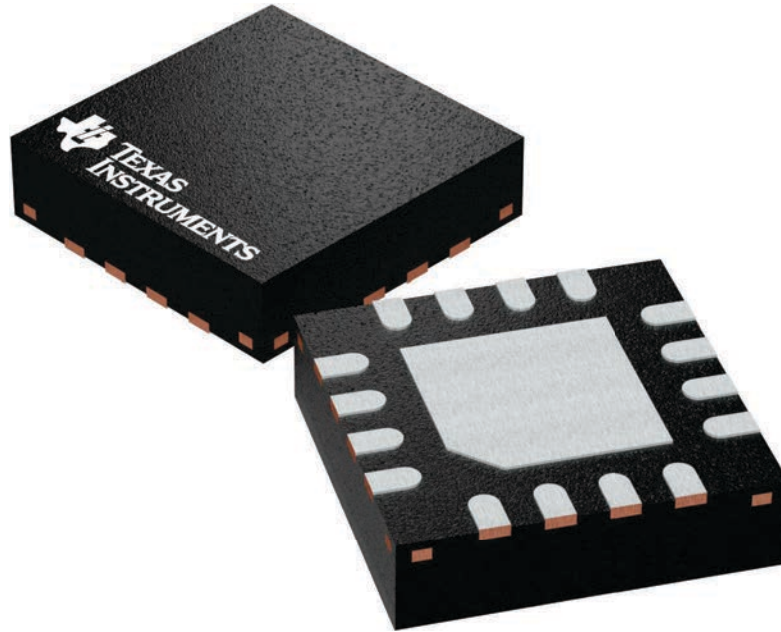

4225944/A

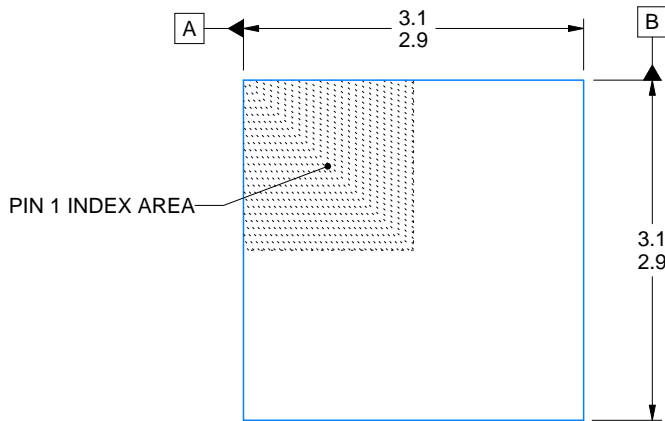

SIDE WALL METAL THICKNESS DIM A	
OPTION 1	OPTION 2
0.1	0.2

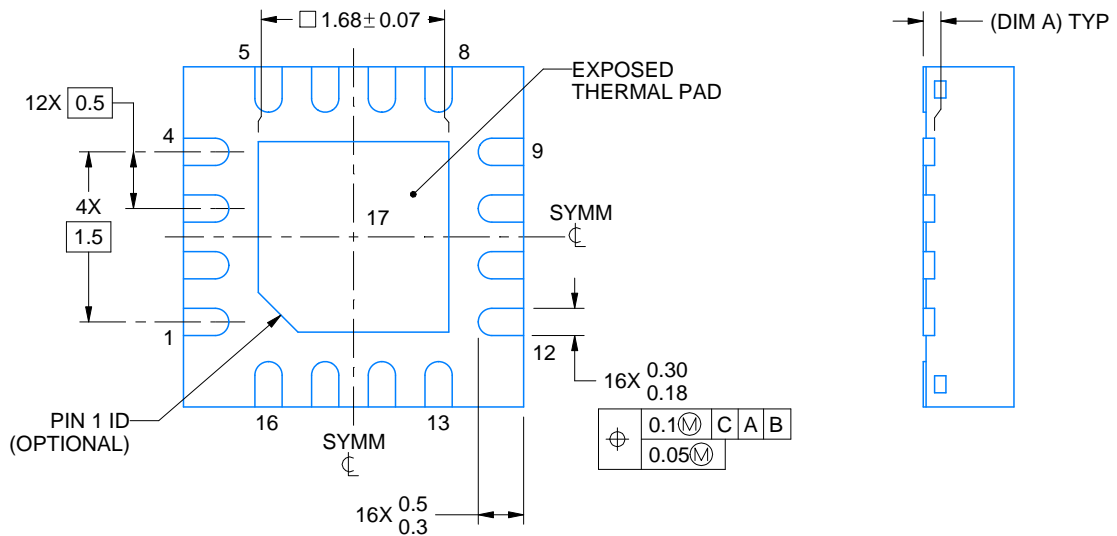
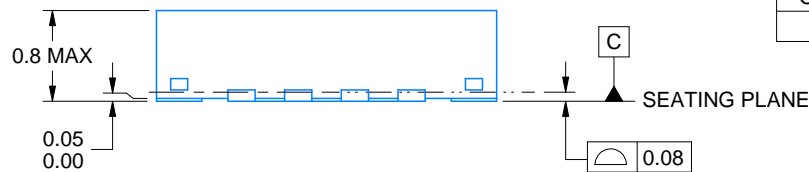

4219117/B 04/2022

NOTES:

1. All linear dimensions are in millimeters. Any dimensions in parenthesis are for reference only. Dimensioning and tolerancing per ASME Y14.5M.
2. This drawing is subject to change without notice.
3. The package thermal pad must be soldered to the printed circuit board for thermal and mechanical performance.

EXAMPLE BOARD LAYOUT

RTE0016C

WQFN - 0.8 mm max height

PLASTIC QUAD FLATPACK - NO LEAD

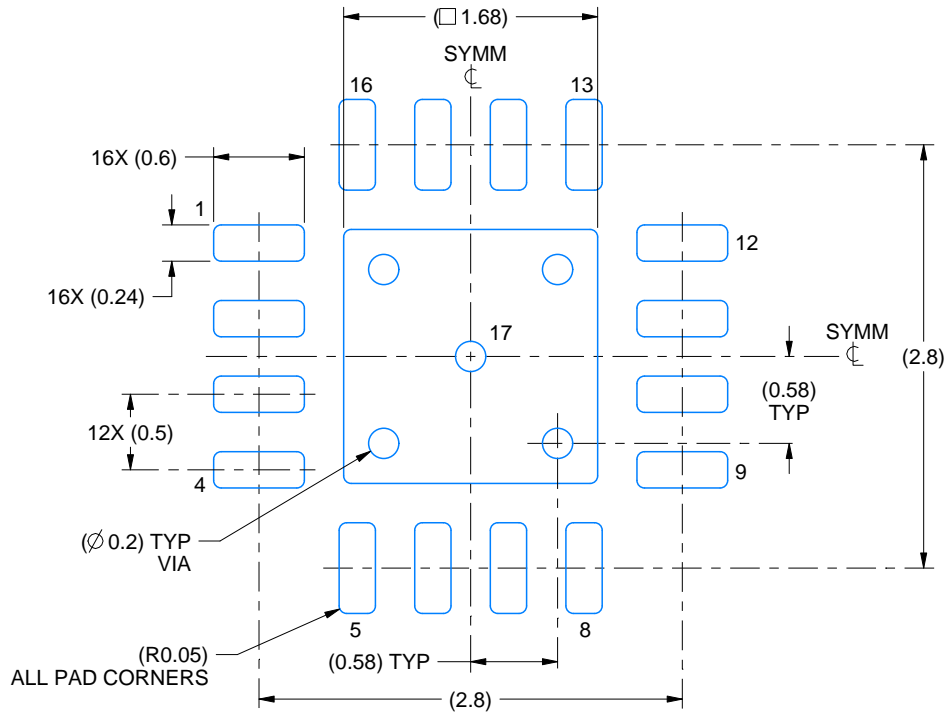

LAND PATTERN EXAMPLE
EXPOSED METAL SHOWN
SCALE:20X

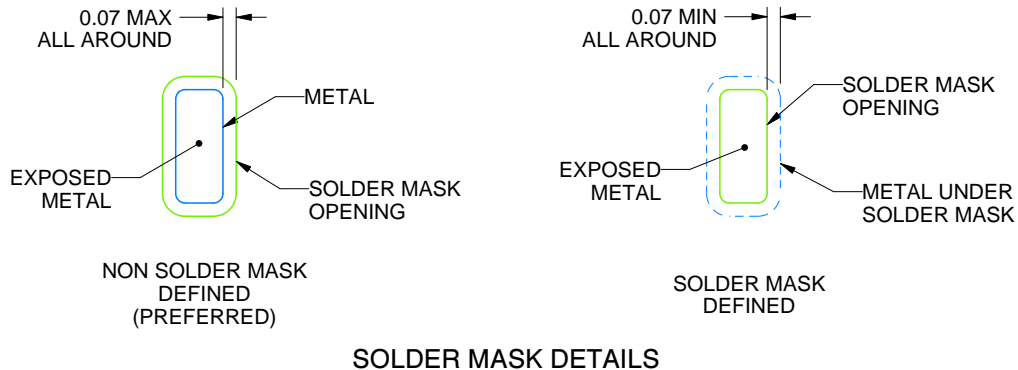

SOLDER MASK DETAILS

4219117/B 04/2022

NOTES: (continued)

- This package is designed to be soldered to a thermal pad on the board. For more information, see Texas Instruments literature number SLUA271 (www.ti.com/lit/slua271).
- Vias are optional depending on application, refer to device data sheet. If any vias are implemented, refer to their locations shown on this view. It is recommended that vias under paste be filled, plugged or tented.

EXAMPLE STENCIL DESIGN

RTE0016C

WQFN - 0.8 mm max height

PLASTIC QUAD FLATPACK - NO LEAD

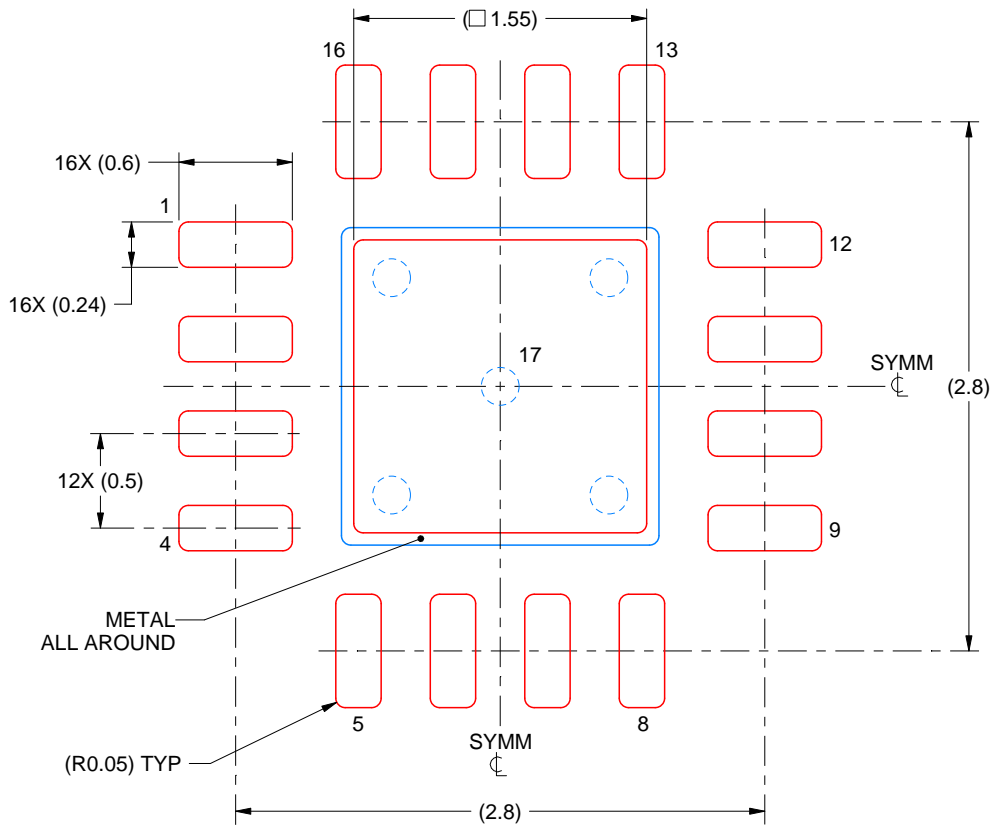

SOLDER PASTE EXAMPLE
BASED ON 0.125 mm THICK STENCIL

EXPOSED PAD 17:
85% PRINTED SOLDER COVERAGE BY AREA UNDER PACKAGE
SCALE:25X

4219117/B 04/2022

NOTES: (continued)

6. Laser cutting apertures with trapezoidal walls and rounded corners may offer better paste release. IPC-7525 may have alternate design recommendations.

IMPORTANT NOTICE AND DISCLAIMER

TI PROVIDES TECHNICAL AND RELIABILITY DATA (INCLUDING DATA SHEETS), DESIGN RESOURCES (INCLUDING REFERENCE DESIGNS), APPLICATION OR OTHER DESIGN ADVICE, WEB TOOLS, SAFETY INFORMATION, AND OTHER RESOURCES "AS IS" AND WITH ALL FAULTS, AND DISCLAIMS ALL WARRANTIES, EXPRESS AND IMPLIED, INCLUDING WITHOUT LIMITATION ANY IMPLIED WARRANTIES OF MERCHANTABILITY, FITNESS FOR A PARTICULAR PURPOSE OR NON-INFRINGEMENT OF THIRD PARTY INTELLECTUAL PROPERTY RIGHTS.

These resources are intended for skilled developers designing with TI products. You are solely responsible for (1) selecting the appropriate TI products for your application, (2) designing, validating and testing your application, and (3) ensuring your application meets applicable standards, and any other safety, security, regulatory or other requirements.

These resources are subject to change without notice. TI grants you permission to use these resources only for development of an application that uses the TI products described in the resource. Other reproduction and display of these resources is prohibited. No license is granted to any other TI intellectual property right or to any third party intellectual property right. TI disclaims responsibility for, and you will fully indemnify TI and its representatives against, any claims, damages, costs, losses, and liabilities arising out of your use of these resources.

TI's products are provided subject to [TI's Terms of Sale](#) or other applicable terms available either on [ti.com](https://www.ti.com) or provided in conjunction with such TI products. TI's provision of these resources does not expand or otherwise alter TI's applicable warranties or warranty disclaimers for TI products.

TI objects to and rejects any additional or different terms you may have proposed.

Mailing Address: Texas Instruments, Post Office Box 655303, Dallas, Texas 75265
Copyright © 2024, Texas Instruments Incorporated

Looking for pricing, stock, or lifecycle information?

Click below to explore more details on WIN SOURCE:

 [View TPS2546RTER](#) on WIN SOURCE

 [Texas Instruments](#) Information

Optimize Your Supply Chain with WIN SOURCE Solutions

-  Global Sourcing Solution
-  Obsolete Management
-  Cost Control Management
-  Shortage Management
-  Alternative Solution
-  Excess Inventory Management