



THE DATASHEET OF TPS2378DDAR



TPS2378 IEEE 802.3at PoE High-Power PD Interface

1 Features

- IEEE 802.3at Type-2 Hardware Classification with Status Flag
- Adapter Priority Input
- DC/DC Converter Enable
- Robust 100 V, 0.5- Ω Hotswap MOSFET
- Operating Current up to 850 mA
- 1-A (Typical) Operating Current Limit
- 15 kV and 8 kV System-level ESD Capability
- PowerPAD™ HSOP Package

2 Applications

- IEEE 802.3at-compliant Devices
- Video and VoIP Telephones
- Multiband Access Points
- Security Cameras
- Pico-base Stations
- Forced, Four-Pair, High Power Devices
([SLVA625](#))

3 Description

This 8-pin integrated circuit contains all of the features needed to implement an IEEE802.3at type-2 powered device (PD). The low 0.5- Ω internal switch resistance, combined with the enhanced thermal dissipation of the PowerPAD™ package, enables this controller to continuously handle up to 0.85 A. The TPS2378 features an auxiliary power detect (APD) input, providing priority for an external power adapter. It also features a 100-V pass transistor, 140-mA inrush current limiting, type-2 indication, auto-retry fault protection, and an open-drain power-good output.

Device Information⁽¹⁾

PART NUMBER	PACKAGE	BODY SIZE (NOM)
TPS2378	HSOP (8)	4.89 mm x 3.90 mm

(1) For all available packages, see the orderable addendum at the end of the data sheet.

Typical Application Circuit

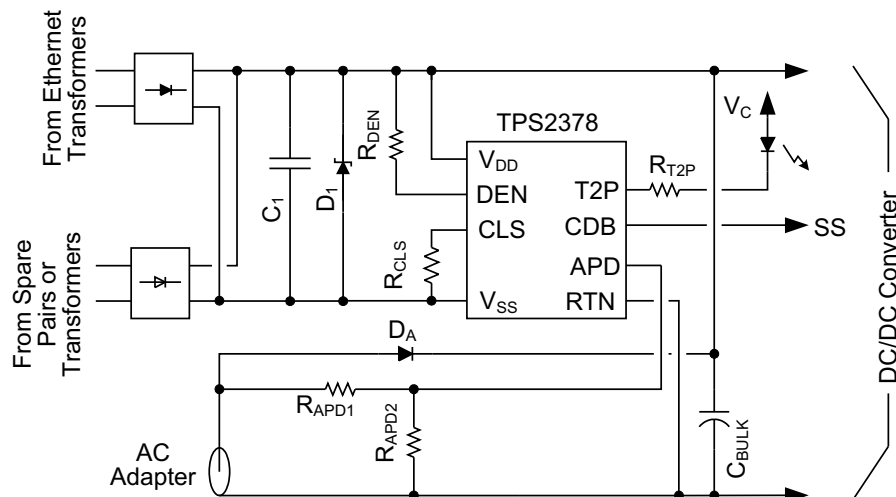

Table of Contents

1 Features	1	8 Application and Implementation	21
2 Applications	1	8.1 Application Information.....	21
3 Description	1	8.2 Typical Application	21
4 Revision History	2	9 Power Supply Recommendations	24
5 Pin Configuration and Functions	3	10 Layout	24
6 Specifications	4	10.1 Layout Guidelines	24
6.1 Absolute Maximum Ratings	4	10.2 Layout Example	24
6.2 ESD Ratings.....	4	10.3 EMI Containment	25
6.3 Recommended Operating Conditions.....	4	10.4 Thermal Considerations and OTSD.....	25
6.4 Thermal Information	5	10.5 ESD.....	25
6.5 Electrical Characteristics.....	5	11 Device and Documentation Support	26
6.6 Typical Characteristics	7	11.1 Documentation Support	26
7 Detailed Description	10	11.2 Community Resources.....	26
7.1 Overview	10	11.3 Trademarks	26
7.2 Functional Block Diagram	10	11.4 Electrostatic Discharge Caution.....	26
7.3 Feature Description.....	10	11.5 Glossary	26
7.4 Device Functional Modes.....	13	12 Mechanical, Packaging, and Orderable Information	26

4 Revision History

NOTE: Page numbers for previous revisions may differ from page numbers in the current version.

Changes from Revision B (November 2012) to Revision C	Page
• Added ESD Ratings table, Feature Description section, Device Functional Modes, Application and Implementation section, Power Supply Recommendations section, Layout section, Device and Documentation Support section, and Mechanical, Packaging, and Orderable Information section	1
• Deleted Detailed Pin Description section.	15
• Deleted CBD Pin Interface section.....	22
• Deleted APD Pin Divider Network, R _{APD1} , R _{APD2} section.....	22

Changes from Revision A (March 2012) to Revision B	Page
• Added Application: Forced, Four-Pair, High Power Devices (SLVA625)	1
• Added Note 1 to the ELECTRICAL CHARACTERISTICS table	6
• Added section: Forced, Four-Pair, High Power PoE	13
• Changed Table 2, From: POWER ≤ 12.95W To: POWER ≤ 13W, From: POWER > 12.95W To POWER > 13W, and PD INPUT POWER (max) From: 12.95 W To 13W	14
• Changed Table 2, PSE Output Power for 802.3at (Type 2) From: 36W to 30W	14
• Changed text in the Detection section From: "(ΔV / ΔI) between 23.75 kΩ and 26.25 kΩ at the PI." To: "(ΔV / ΔI) between 23.7 kΩ and 26.3 kΩ at the PI."	16
• Added text to the Startup and Converter Operation section: "Additional loading applied between V _{VDD} and V _{RTN} during the inrush state may prevent successful PD and subsequent converter start up."	17
• Changed text in the Detection Resistor, R _{DEN} section From: "R _{DEN} between 23.75 kΩ and 26.25 kΩ, or 25 kΩ ± 5%." To: "R _{DEN} between 23.7 kΩ and 26.3 kΩ, or 25 kΩ ± 5%."	22

Changes from Original (March 2012) to Revision A	Page
• Changed the Inrush termination MAX value From: 100% To: 99%	5

5 Pin Configuration and Functions

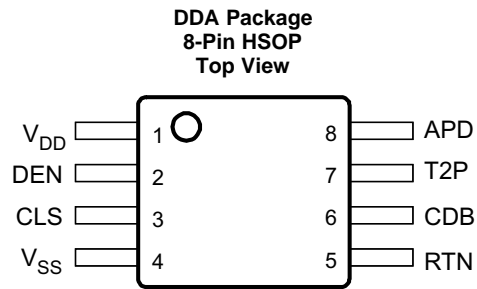

Pin Functions

PIN		I/O	DESCRIPTION
NAME	NO.		
V _{DD}	1	I	Connect to positive PoE input power rail. Bypass with 0.1 μ F to V _{SS} .
DEN	2	I/O	Connect 24.9 k Ω to V _{DD} for detection. Pull to V _{SS} disable pass MOSFET.
CLS	3	O	Connect resistor from CLS to V _{SS} to program classification current.
V _{SS}	4	—	Connect to negative power rail derived from PoE source.
RTN	5	—	Drain of PoE pass MOSFET.
CDB	6	O	Active low, open-drain converter disable output, referenced to RTN.
T2P	7	O	Active low indicates type 2 PSE connected or APD active.
APD	8	I	Raise 1.5 V above RTN to disable pass MOSFET and force T2P active.
Pad	—	—	The PowerPad™ must be connected to V _{SS} . A large fill area is required to assist in heat dissipation.

6 Specifications

6.1 Absolute Maximum Ratings

over recommended T_J range; voltages with respect to V_{VSS} (unless otherwise noted)⁽¹⁾

		MIN	MAX	UNIT
Input voltage	V_{DD} , DEN	-0.3	100	V
	RTN ⁽²⁾	-0.6	100	
	CLS ⁽³⁾	-0.3	6.5	
	APD to RTN	-0.3	19	
	[CDB, T2P] to RTN	-0.3	100	
Sinking current	RTN ⁽⁴⁾	Internally limited		mA
	CDB, T2P	5		
	DEN	1		
Sourcing current	CLS	65		mA
T_{JMAX}	Maximum junction temperature	Internally limited		°C
T_{stg}	Storage temperature	-65	150	°C

- (1) Stresses beyond those listed under *Absolute Maximum Ratings* may cause permanent damage to the device. These are stress ratings only, which do not imply functional operation of the device at these or any other conditions beyond those indicated under *Recommended Operating Conditions*. Exposure to absolute-maximum-rated conditions for extended periods may affect device reliability.
- (2) With $I_{(RTN)} = 0$
- (3) Do not apply voltages to these pins
- (4) SOA limited to RTN = 80 V at 1.2 A.

6.2 ESD Ratings

		VALUE	UNIT
$V_{(ESD)}$ Electrostatic discharge	Human body model (HBM), per ANSI/ESDA/JEDEC JS-001, all pins ⁽¹⁾	2000	V
	Charged device model (CDM), per JEDEC specification JESD22-C101, all pins ⁽²⁾	500	
	IEC 61000-4-2 contact discharge ⁽³⁾	8000	
	IEC 61000-4-2 air-gap discharge ⁽³⁾	15000	

- (1) JEDEC document JEP155 states that 500-V HBM allows safe manufacturing with a standard ESD control process.
- (2) JEDEC document JEP157 states that 250-V CDM allows safe manufacturing with a standard ESD control process.
- (3) Discharges applied to circuit of [Figure 24](#) between RJ-45, adapter, and output voltage rails

6.3 Recommended Operating Conditions

over operating free-air temperature range and voltages with respect to V_{SS} (unless otherwise noted)

		MIN	NOM	MAX	UNIT
Input voltage range	RTN, VDD	0		57	V
	APD to RTN	0		18	
	CDB, T2P to RTN	0		57	
Sinking current	RTN			0.85	A
	CDB, T2P			2	mA
Resistance	CLS ⁽¹⁾	60			Ω
Junction temperature		-40		125	°C

- (1) Voltage should not be externally applied to this pin.

6.4 Thermal Information

THERMAL METRIC ⁽¹⁾		TPS2378		UNIT
		SO-8 PowerPad™		
		8 PINS		
R _{θJA}	Junction-to-ambient thermal resistance	45.9		°C/W
R _{θJC(top)}	Junction-to-case (top) thermal resistance	51.9		°C/W
R _{θJB}	Junction-to-board thermal resistance	28.8		°C/W
ψ _{JT}	Junction-to-top characterization parameter	8.9		°C/W
ψ _{JB}	Junction-to-board characterization parameter	28.7		°C/W
R _{θJC(bot)}	Junction-to-case (bottom) thermal resistance	6.7		°C/W

(1) For more information about traditional and new thermal metrics, see the *Semiconductor and IC Package Thermal Metrics* application report, [SPRA953](#).

6.5 Electrical Characteristics

40 V ≤ V_{VDD} ≤ 57 V, R_{DEN} = 24.9 kΩ, V_{CDB}, V_{CLS}, and V_{T2P} open; V_{APD} = V_{RTN}; -40°C ≤ T_J ≤ 125°C. Positive currents are into pins. Typical values are at 25°C. All voltages are with respect to V_{VSS} unless otherwise noted.

PARAMETER		TEST CONDITIONS	MIN	TYP	MAX	UNIT
DETECTION (DEN)						
Bias current		DEN open, V _{VDD} = 10.1 V, Measure I _{SUPPLY} (VDD, RTN, DEN), Not in mark	3	4.8	12	μA
Detection current		Measure I _{SUPPLY} (VDD, RTN, DEN), V _{DD} = 1.4 V	53.8	56.5	58.3	μA
		Measure I _{SUPPLY} (VDD, RTN, DEN), V _{DD} = 10.1 V, Not in mark	395	410	417	
V _{PD_DIS}	Disable threshold	DEN falling	3	3.7	5	V
	Hysteresis		50	113	200	mV
AUXILIARY POWER DETECTION (APD)						
V _{APDEN}	Voltage threshold	V _{APD} rising, measure to V _{RTN}	1.4	1.5	1.6	V
V _{APDH}		Hysteresis, measure to V _{RTN}	0.27	0.3	0.33	
Sinking current		V _(APD-RTN) = 5 V, measure I _{APD}	1	1.73	3	μA
CLASSIFICATION (CLS)						
I _{CLS} Classification current		13 V ≤ V _{VDD} ≤ 21 V, Measure I _{VDD} + I _{DEN} + I _{RTN}				
		R _{CLS} = 1270 Ω	1.8	2.17	2.6	mA
		R _{CLS} = 243 Ω	9.9	10.6	11.2	
		R _{CLS} = 137 Ω	17.6	18.6	19.4	
		R _{CLS} = 90.9 Ω	26.5	27.9	29.3	
		R _{CLS} = 63.4 Ω	38	39.9	42	
V _{CL_ON}	Class lower threshold	V _{VDD} rising, I _{CLS} ↑	11.9	12.5	13	
V _{CL_H}		Hysteresis	1.4	1.6	1.7	
V _{CU_ON}	Class upper threshold	V _{VDD} rising, I _{CLS} ↓	21	22	23	V
V _{CU_H}		Hysteresis	0.5	0.78	0.9	
V _{MSR}	Mark reset threshold	V _{VDD} falling	3	3.9	5	V
Mark state resistance		2-point measurement at 5 V and 10.1 V	6	10	12	kΩ
Leakage current		V _{VDD} = 57 V, V _{CLS} = 0 V, measure I _{CLS}			1	μA
PASS DEVICE (RTN)						
r _{DS(on)}	On resistance		0.2	0.42	0.75	Ω
Input bias current		V _{VDD} = V _{RTN} = 30 V, measure I _{RTN}			30	μA
Current limit		V _{RTN} = 1.5 V	0.85	1	1.2	A
Inrush current limit		V _{RTN} = 2 V, V _{VDD} : 20 V → 48 V	100	140	180	mA
Inrush termination		Percentage of inrush current	80%	90%	99%	
Foldback threshold		V _{RTN} rising	11	12.3	13.6	V

Electrical Characteristics (continued)

40 V ≤ V_{VDD} ≤ 57 V, R_{DEN} = 24.9 kΩ, V_{CDB}, V_{CLS}, and V_{T2P} open; V_{APD} = V_{RTN}; –40°C ≤ T_J ≤ 125°C. Positive currents are into pins. Typical values are at 25°C. All voltages are with respect to V_{VSS} unless otherwise noted.

PARAMETER		TEST CONDITIONS	MIN	TYP	MAX	UNIT
Foldback deglitch time		V _{RTN} rising to when current limit changes to inrush current limit	500	800	1500	μs
CONVERTER DISABLE (CDB)						
Output low voltage		Measure V _{CDB} – V _{RTN} , I _{CDB} = 2 mA, V _{RTN} = 2 V, V _{DD} : 20 V → 48 V		0.27	0.5	V
Leakage current		V _{CDB} = 57 V, V _{RTN} = 0 V			10	μA
TYPE 2 PSE INDICATION (T2P)						
V _{T2P}	Output low voltage	I _{T2P} = 2 mA, after 2-event classification and inrush is complete, V _{RTN} = 0 V		0.26	0.6	V
Leakage current		V _{T2P} = 57 V, V _{RTN} = 0 V			10	μA
UVLO						
V _{UVLO_R}	UVLO rising threshold	V _{VDD} rising	36.3	38.1	40	V
	UVLO falling threshold	V _{VDD} falling	30.5	32	33.6	
V _{UVLO_H}	UVLO hysteresis			6.1		V
THERMAL SHUTDOWN						
Shutdown		T _J ↑	135	145		°C
Hysteresis ⁽¹⁾				20		
BIAS CURRENT						
Operating current		40 V ≤ V _{VDD} ≤ 57 V		285	500	μA

(1) Parameters provided for reference only, and do not constitute part of TI published specifications for purposes of TI product warranty.

6.6 Typical Characteristics

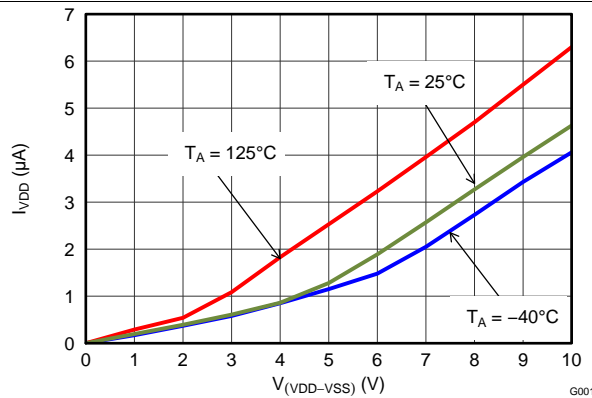

Figure 1. Detection Bias Current vs PoE Voltage

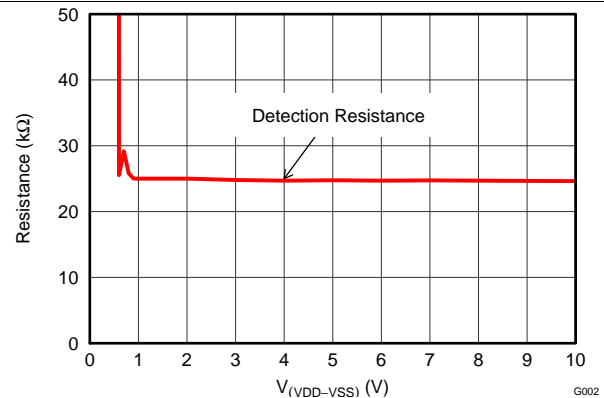

Figure 2. Detection Resistance vs PoE Voltage

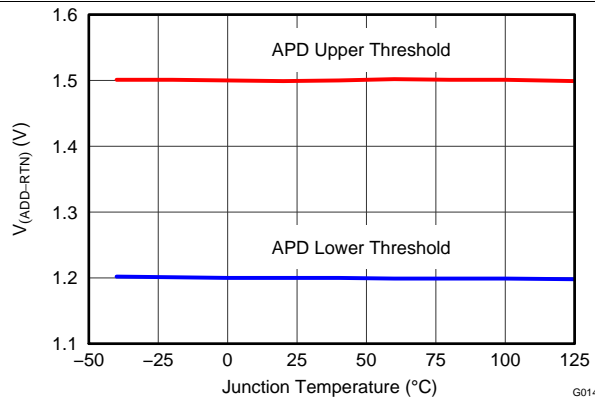

Figure 3. APD Threshold Voltage vs Temperature

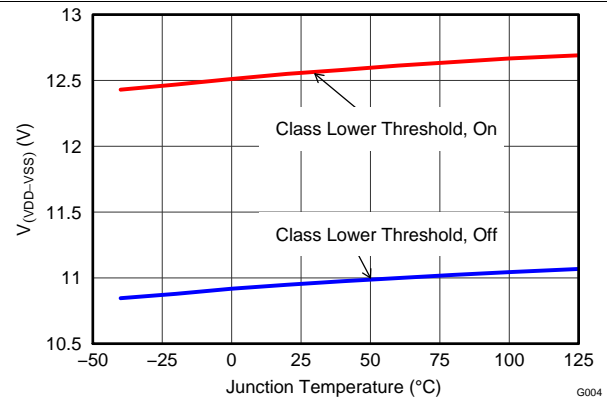

Figure 4. Classification Lower Threshold vs Temperature

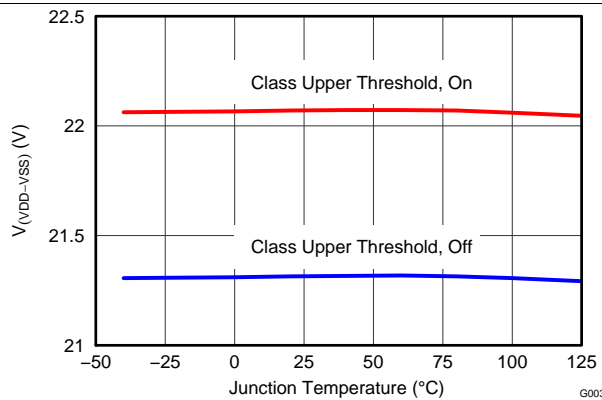

Figure 5. Classification Upper Threshold vs Temperature

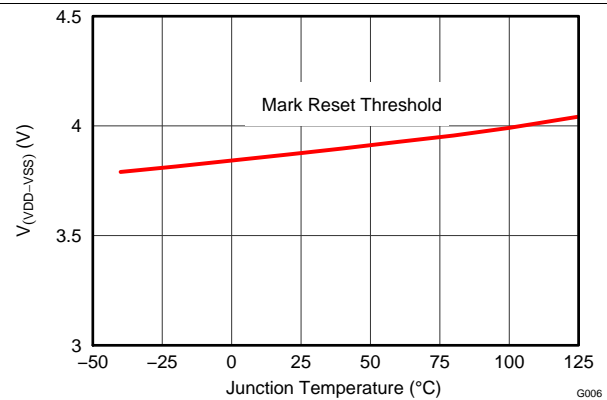

Figure 6. Mark Reset Threshold vs Temperature

Typical Characteristics (continued)

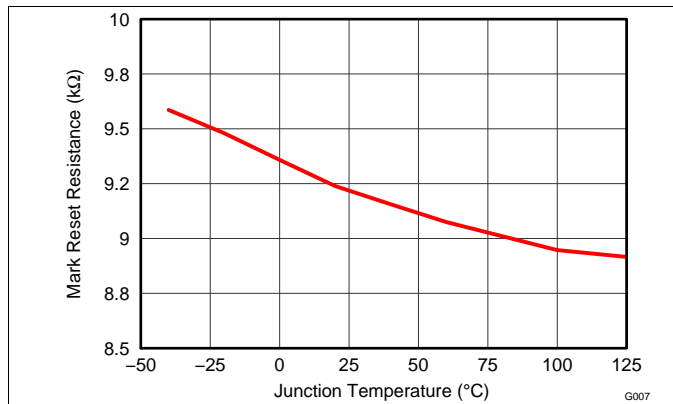

Figure 7. Mark Resistance vs PoE Voltage

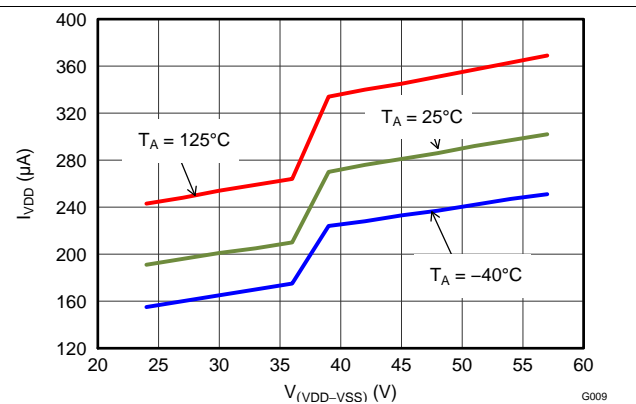

Figure 8. I_VDD Bias Current vs Voltage

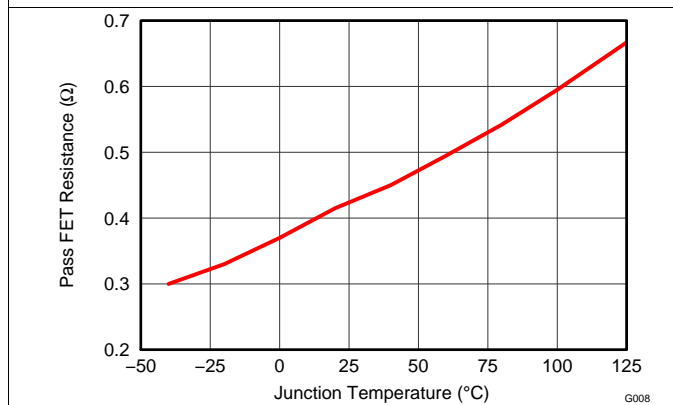

Figure 9. Pass FET Resistance vs Temperature

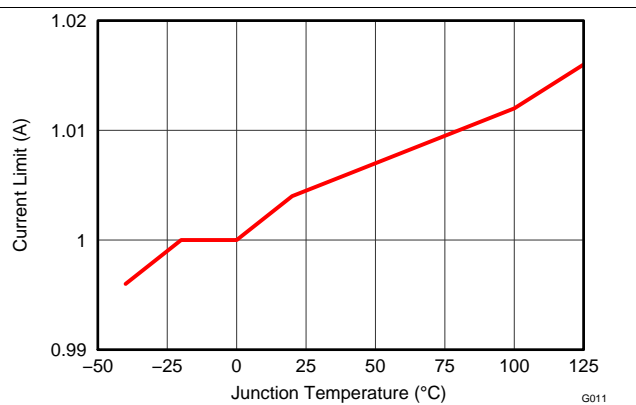

Figure 10. PoE Current Limit vs Temperature

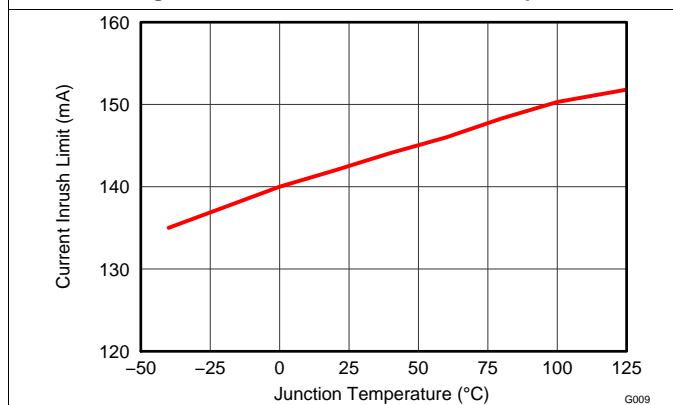

Figure 11. PoE Inrush Current Limit vs Temperature

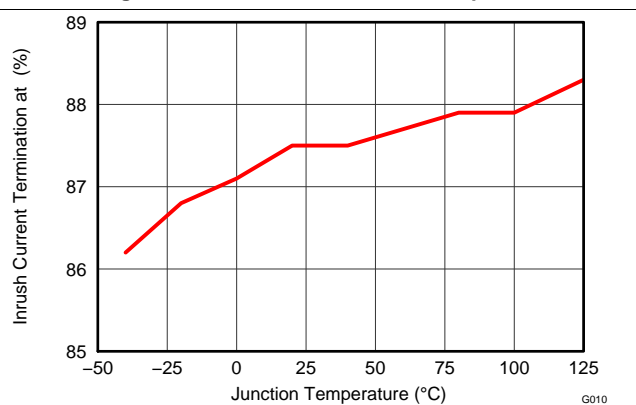
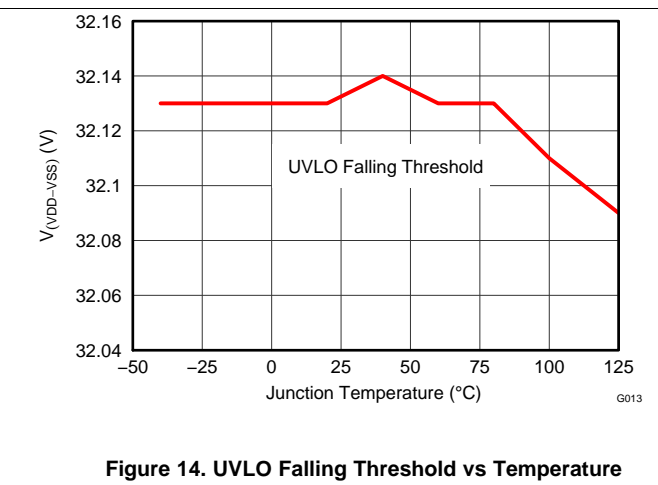
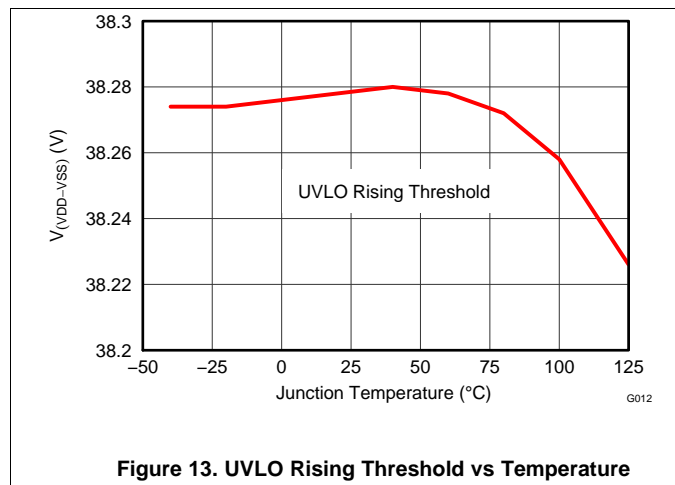

Figure 12. Inrush Termination Threshold vs Temperature

Typical Characteristics (continued)



7 Detailed Description

7.1 Overview

The TPS2378 device is an 8-pin integrated circuit that contains all of the features needed to implement an IEEE802.3at type-2 powered device (PD) such as Detection, Classification, Type 2 Hardware Classification, and 140-mA inrush current limit during start-up.

The TPS2378 integrates a low 0.5-Ω internal switch to allow for up to 0.85 A of continuous current through the PD during normal operation.

The TPS2378 features an auxiliary power detect (APD) input, providing priority for an external power adapter.

The TPS2378 contains several protection features such as thermal shutdown, current limit foldback, and a robust 100-V internal switch.

7.2 Functional Block Diagram

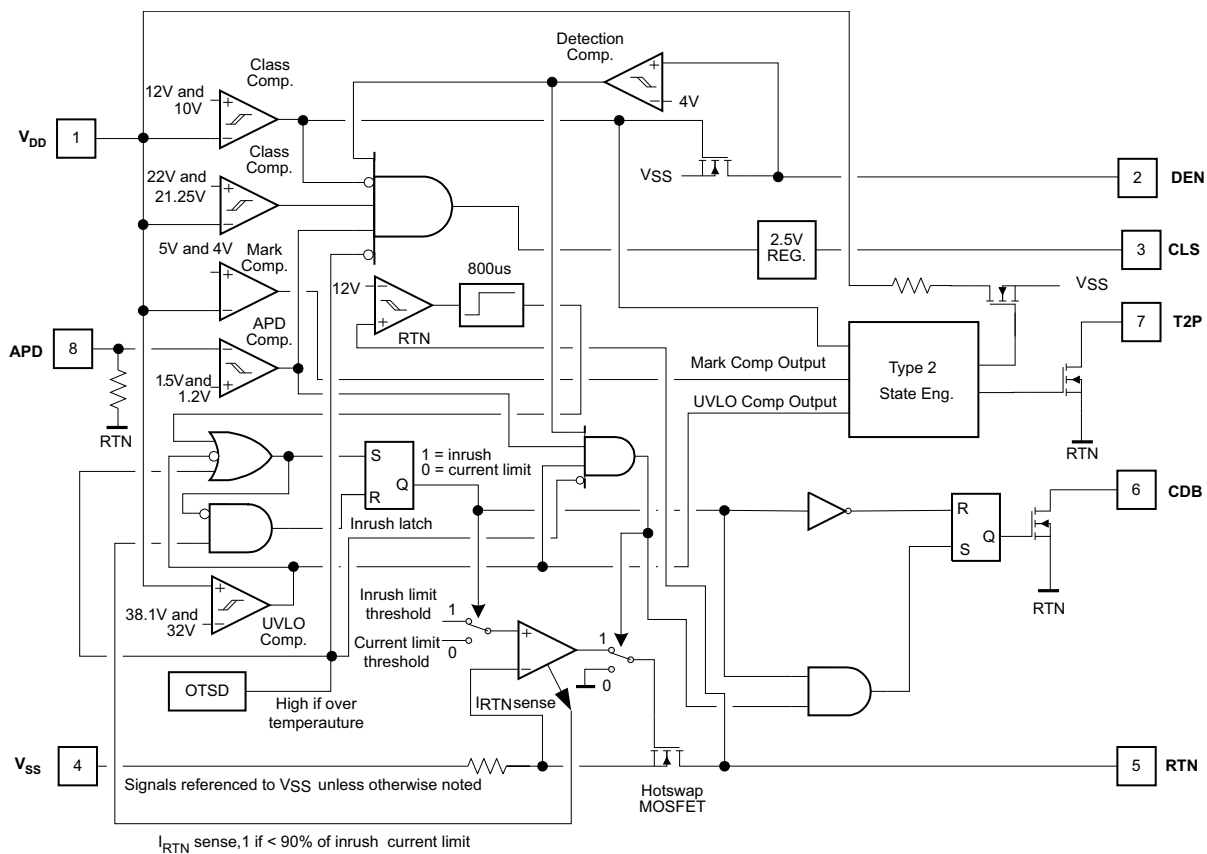

7.3 Feature Description

7.3.1 APD Auxiliary Power Detect

The APD pin is used in applications that may draw power either from the Ethernet cable or from an auxiliary power source. A voltage of more than about 1.5 V on the APD pin relative to RTN turns off the internal pass MOSFET, disables the CLS output, and enables the T2P output, giving adapter source priority over the PoE. A resistor divider (R_{APD1} – R_{APD2} in Figure 24) provides system-level ESD protection for the APD pin, discharges leakage from the blocking diode (D_A in Figure 24) and provides input voltage supervision to ensure that switch-over to the auxiliary voltage source does not occur at excessively low voltages. If not used, connect APD to RTN.

Feature Description (continued)

7.3.2 CDB Converter Disable Bar Pin Interface

CDB is an active low output that is pulled to RTN when the device is in inrush current limiting. It remains in a high impedance state at all other times. This pin is an open-drain output, and it may require a pullup resistor or other interface to the downstream load. CDB may be left open if it is not used.

The CDB pin can be used to inhibit downstream converter start-up by keeping the soft start pin low. Figure 15 shows an example where CDB connects to the SS pin of a UCC2897A DC-DC controller. Because CDB is an open drain output, it will not affect the soft start capacitor charge time when it deasserts. Another common use of the CDB pin is to enable a converter with an active-high enable input. In this case, CDB may require a pullup resistor to either VDD, or to a bias supply, depending on the requirements of the controller enable pin.

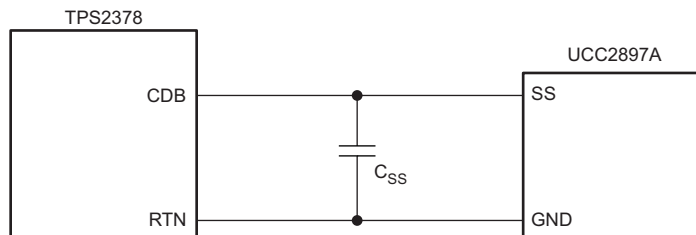

Figure 15. CDB Interface

7.3.3 CLS Classification

An external resistor (RCLS in Figure 24) connected between the CLS pin and VSS provides a classification signature to the PSE. The controller places a voltage of approximately 2.5 V across the external resistor whenever the voltage differential between VDD and VSS lies from about 10.9 V to 22 V. The current drawn by this resistor, combined with the internal current drain of the controller and any leakage through the internal pass MOSFET, creates the classification current. Table 1 lists the external resistor values required for each of the PD power ranges defined by IEEE802.3at. The maximum average power drawn by the PD, plus the power supplied to the downstream load, should not exceed the maximum power indicated in Table 1. Holding APD high disables the classification signature.

High-power PSEs may perform two classification cycles if Class 4 is presented on the first cycle.

Table 1. Class Resistor Selection

CLASS	MINIMUM POWER AT PD (W)	MAXIMUM POWER AT PD (W)	RESISTOR (Ω)
0	0.44	12.95	1270
1	0.44	3.84	243
2	3.84	6.49	137
3	6.49	12.95	90.9
4	12.95	25.5	63.4

7.3.4 DEN Detection and Enable

DEN pin implements two separate functions. A resistor (R_{DEN} in Figure 24) connected between V_{DD} and DEN generates a detection signature whenever the voltage differential between V_{DD} and V_{SS} lies from approximately 1.4 to 10.9 V. Beyond this range, the controller disconnects this resistor to save power. The IEEE 802.3at standard specifies a detection signature resistance, R_{DEN} from 23.75 k Ω to 26.25 k Ω , or 25 k Ω \pm 5%. TI recommends a resistor of 24.9 k Ω \pm 1% for R_{DEN} .

If the resistance connected between V_{DD} and DEN is divided into two roughly equal portions, then the application circuit can disable the PD by grounding the tap point between the two resistances. This action simultaneously spoils the detection signature and thereby signals the PSE that the PD no longer requires power.

7.3.5 Internal Pass MOSFET

RTN pin provides the negative power return path for the load. Once V_{DD} exceeds the UVLO threshold, the internal pass MOSFET pulls RTN to VSS. Inrush limiting prevents the RTN current from exceeding about 140 mA until the bulk capacitance (C_{BULK} in Figure 24) is fully charged. Inrush ends when the RTN current drops below about 125 mA. The RTN current is subsequently limited to about 1 A. The CDB pulls low to signal the downstream load that the bulk capacitance is fully charged. If RTN ever exceeds about 12 V for longer than 800 μ s, then the TPS2378 returns to inrush limiting.

7.3.6 T2P Type-2 PSE Indicator

The TPS2378 pulls T2P to RTN whenever type-2 hardware classification has been observed or the APD pin is pulled high. The T2P output will return to a high-impedance state if the part enters thermal shutdown, the pass MOSFET enters inrush limiting, or if a type-2 PSE was not detected and the voltage on APD drops below its threshold. The circuitry that watches for type-2 hardware classification latches its result when the V_{DD} -to- V_{SS} voltage differential rises above the upper classification threshold. This circuit resets when the V_{DD} -to- V_{SS} voltage differential drops below the mark threshold. The T2P pin can be left unconnected if it is not used.

The T2P pin is an active-low, open-drain output, which indicates that a high power source is available. An optocoupler can interface the T2P pin to circuitry on the secondary side of the converter. A high-gain optocoupler and a high-impedance (for example, CMOS) receiver are recommended. Design of the T2P optocoupler interface can be accomplished as follows:

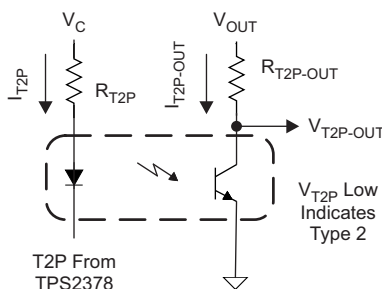

Figure 16. T2P Interface

- As shown in Figure 16, let $V_C = 12$ V, $V_{OUT} = 5$ V, $R_{T2P-OUT} = 10$ k Ω , $V_{T2P} = 260$ mV, $V_{T2P} = 400$ mV.

$$I_{T2P-OUT} = \frac{V_{OUT} - V_{T2P-OUT}}{R_{T2P-OUT}} = \frac{5 - 0.4}{10000} = 0.46\text{mA} \quad (1)$$

- The optocoupler current transfer ratio, CTR, is needed to determine R_{T2P} . A device with a minimum CTR of 100% at 1 mA LED bias current, I_{T2P} , is selected. In practice, CTR will vary with temperature, LED bias current, and aging. These variations may require some iteration using the CTR-versus-LED current curve on the optocoupler data sheet.

(a) The approximate forward voltage of the optocoupler diode, V_{FWLED} , is 1.1 V from the data sheet.

(b) Use Equation 2.

$$I_{T2P-MIN} = \frac{I_{T2P-OUT}}{CTR} = \frac{0.46\text{mA}}{1.00} = 0.46\text{mA}, \text{ Select } I_{T2P} = 1\text{mA}$$

$$R_{T2P} = \frac{V_C - V_{T2P} - V_{FWLED}}{I_{T2P}} = \frac{12\text{ V} - 0.26\text{ V} - 1.1\text{ V}}{1\text{mA}} = 10.6\text{k}\Omega \quad (2)$$

(c) Select a 10.7-k Ω resistor.

7.3.7 VDD Supply Voltage

VDD pin connects to the positive side of the input supply. It provides operating power to the PD controller and allows monitoring of the input line voltage.

7.3.8 VSS

VSS pin is the input supply negative rail that serves as a local ground. The PowerPAD must be connected to this pin to ensure proper operation.

7.3.9 PowerPAD

The PowerPAD is internally connected to V_{SS} . It should be tied to a large V_{SS} copper area on the PCB to provide a low resistance thermal path to the circuit board. TI recommends maintaining a clearance of 0.025" between V_{SS} and high-voltage signals such as V_{DD} .

7.3.10 Forced, Four-Pair, High Power PoE

TPS2378 can be arranged in a dual fashion to support high power, four pair operation at 51 W at the input RJ45 connector. Additional information is available in the *Dual TPS2378 PD for 51 W High Power-Four Pair PoE (SLVA625)* application report.

7.4 Device Functional Modes

7.4.1 PoE Overview

The following text is intended as an aid in understanding the operation of the TPS2378 but not as a substitute for the IEEE 802.3at standard. The IEEE 802.3at standard is an update to IEEE 802.3-2008 clause 33 (PoE), adding high-power options and enhanced classification. Generally speaking, a device compliant to IEEE 802.3-2008 is referred to as a type 1 device, and devices with high power and enhanced classification will be referred to as type 2 devices. Standards change and should always be referenced when making design decisions.

The IEEE 802.3at standard defines a method of safely powering a PD (powered device) over a cable by power sourcing equipment (PSE), and then removing power if a PD is disconnected. The process proceeds through an idle state and three operational states of detection, classification, and operation. The PSE leaves the cable unpowered (idle state) while it periodically looks to see if something has been plugged in; this is referred to as detection. The low power levels used during detection are unlikely to damage devices not designed for PoE. If a valid PD signature is present, the PSE may inquire how much power the PD requires; this is referred to as classification. The PSE may then power the PD if it has adequate capacity.

Type 2 PSEs are required to do type 1 hardware classification plus a (new) data-layer classification, or an enhanced type 2 hardware classification. Type 1 PSEs are not required to do hardware or data link layer (DLL) classification. A type 2 PD must do type 2 hardware classification as well as DLL classification. The PD may return the default, 13-W current-encoded class, or one of four other choices. DLL classification occurs after power-on and the Ethernet data link has been established.

Once started, the PD must present a maintain power signature (MPS) to assure the PSE that it is still present. The PSE monitors its output for a valid MPS, and turns the port off if it loses the MPS. Loss of the MPS returns the PSE to the idle state. [Figure 17](#) shows the operational states as a function of PD input voltage. The upper half is for IEEE 802.3-2008, and the lower half shows specific differences for IEEE 802.3at. The dashed lines in the lower half indicate these are the same (for example, Detect and Class) for both.

Device Functional Modes (continued)

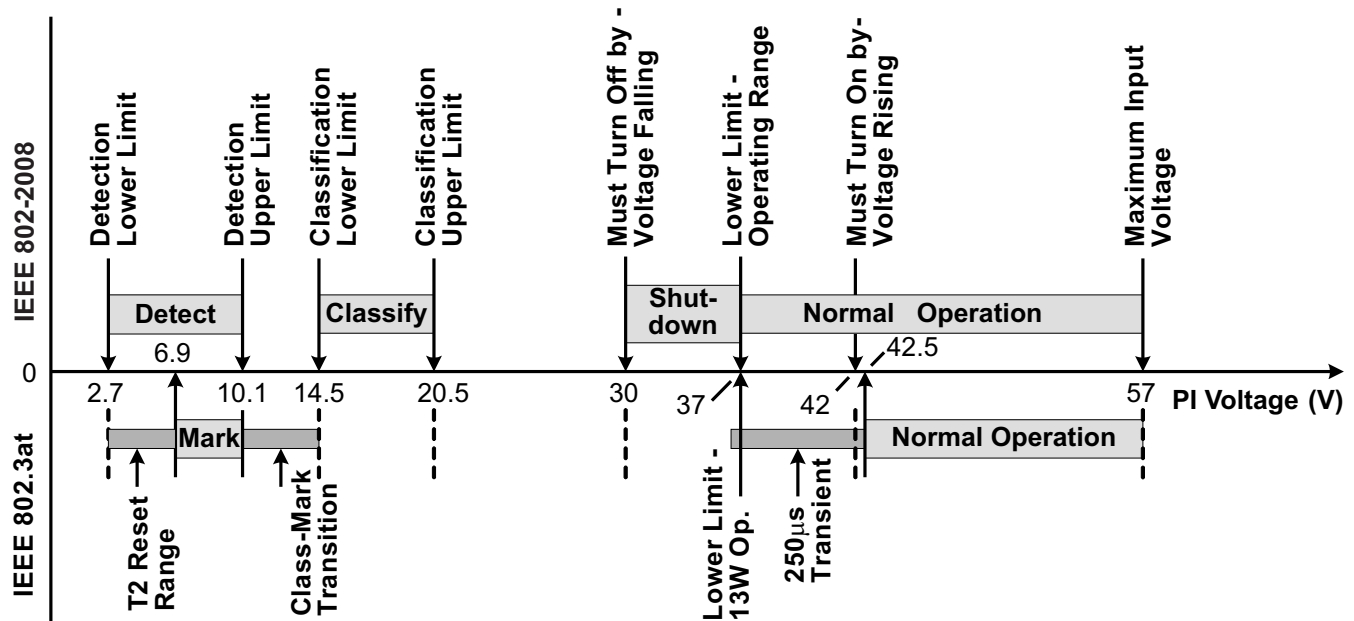

Figure 17. Threshold Voltages

The PD input, typically an RJ-45 eight-lead connector, is referred to as the power interface (PI). PD input requirements differ from PSE output requirements to account for voltage drops and operating margin. The standard allots the maximum loss to the cable regardless of the actual installation to simplify implementation. IEEE 802.3-2008 was designed to run over infrastructure including ISO/IEC 11801 class C (CAT3 per TIA/EIA-568) that may have had AWG 26 conductors. IEEE 802.3at type 2 cabling power loss allotments and voltage drops have been adjusted for 12.5-Ω power loops per ISO/IEC11801 class D (CAT5 or higher per TIA/EIA-568, typically AWG 24 conductors). Table 2 shows key operational limits broken out for the two revisions of the standard.

Table 2. Comparison of Operational Limits

STANDARD	POWER LOOP RESISTANCE (MAX)	PSE OUTPUT POWER (MIN)	PSE STATIC OUTPUT VOLTAGE (MIN)	PD INPUT POWER (MAX)	STATIC PD INPUT VOLTAGE	
					POWER ≤ 13 W	POWER > 13 W
IEEE802.3at-2008 802.3at (Type 1)	20 Ω	15.4 W	44 V	13 W	37 V – 57 V	N/A
802.3at (Type 2)	12.5 Ω	30 W	50 V	25.5 W	37 V – 57 V	42.5 V – 57 V

The PSE can apply voltage either between the RX and TX pairs (pins 1–2 and 3–6 for 10baseT or 100baseT), or between the two spare pairs (4–5 and 7–8). Power application to the same pin combinations in 1000baseT systems is recognized in IEEE 802.3at. 1000baseT systems can handle data on all pairs, eliminating the spare pair terminology. The PSE may only apply voltage to one set of pairs at a time. The PD uses input diode bridges to accept power from any of the possible PSE configurations. The voltage drops associated with the input bridges create a difference between the standard limits at the PI and the TPS2378 specifications.

A compliant type 2 PD has power management requirements not present with a type 1 PD. These requirements include the following:

1. Must interpret type 2 hardware classification.
2. Must present hardware class 4.
3. Must implement DLL negotiation.
4. Must behave like a type 1 PD during inrush and start-up.
5. Must not draw more than 13 W for 80 ms after the PSE applies operating voltage (power up).

6. Must not draw more than 13 W if it has not received a type 2 hardware classification or received permission through DLL.
7. Must meet various operating and transient templates.
8. Optionally monitor for the presence or absence of an adapter (assume high power).

As a result of these requirements, the PD must be able to dynamically control its loading, and monitor T2P for changes. In cases where the design needs to know specifically if an adapter is plugged in and operational, the adapter should be individually monitored, typically with an optocoupler.

7.4.2 Threshold Voltages

The TPS2378 has a number of internal comparators with hysteresis for stable switching between the various states. Figure 18 relates the parameters in Electrical Characteristics to the PoE states. The mode labeled Idle between Classification and Operation implies that the DEN, CLS, and RTN pins are all high impedance. The state labeled Mark, which is drawn in dashed lines, is part of the new type 2 hardware class state machine.

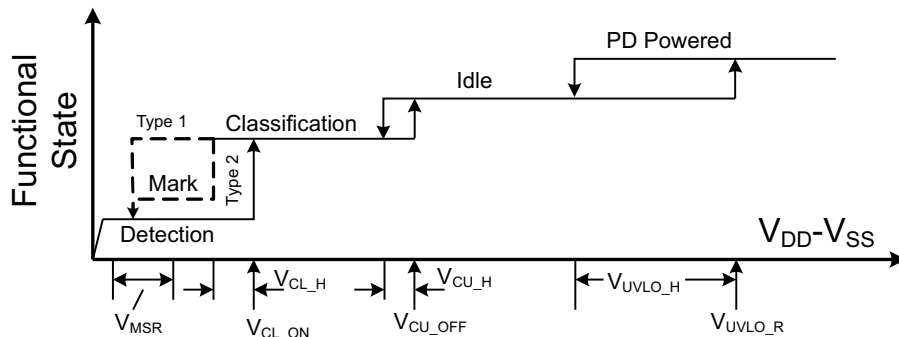

Note: Variable names refer to Electrical Characteristic Table parameters

Figure 18. Threshold Voltages

7.4.3 PoE Start-up Sequence

The waveforms of Figure 19 demonstrate detection, classification, and start-up from a PSE with type 2 hardware classification. The key waveforms shown are $V_{(VDD-VSS)}$, $V_{(RTN-VSS)}$, and I_{PI} . IEEE 802.3at requires a minimum of two detection levels, two class and mark cycles, and start-up from the second mark event. V_{RTN} to V_{SS} falls as the TPS2378 charges C_{BULK} following application of full voltage. In Figure 19, deassertion of the CDB signal is delayed and used to enable load current as seen in the I_{PI} waveform.

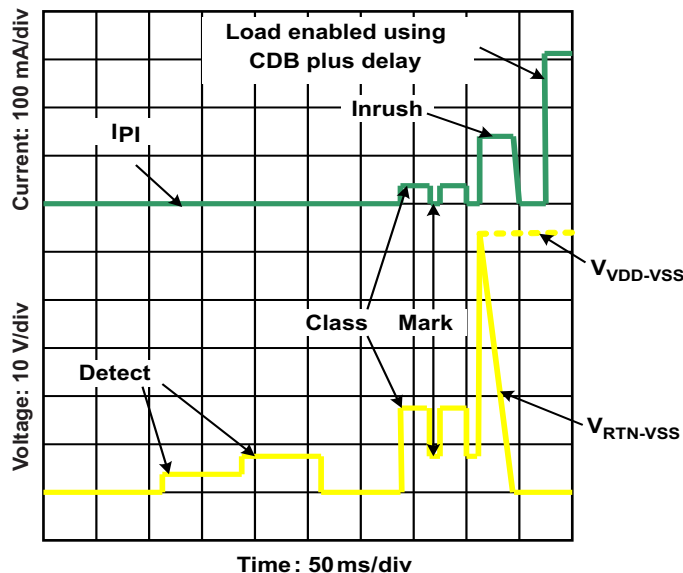

Figure 19. Start-up

7.4.4 Detection

The TPS2378 pulls DEN to V_{SS} whenever $V_{(VDD-VSS)}$ is below the lower classification threshold. When the input voltage rises above V_{CL_ON} , the DEN pin goes to an open-drain condition to conserve power. While in detection, RTN is high impedance, and almost all the internal circuits are disabled. An R_{DEN} of 24.9 k Ω ($\pm 1\%$), presents the correct signature. It may be a small, low-power resistor because it only sees a stress of about 5 mW. A valid PD detection signature is an incremental resistance ($\Delta V / \Delta I$) from 23.7 k Ω to 26.3 k Ω at the PI.

The detection resistance seen by the PSE at the PI is the result of the input bridge resistance in series with the parallel combination of R_{DEN} and internal V_{DD} loading. The input diode bridge's incremental resistance may be hundreds of Ω at the low currents drawn when 2.7 V is applied to the PI. The input bridge resistance is partially compensated by the TPS2378 effective resistance during detection.

The type 2 hardware classification protocol of IEEE 802.3at specifies that a type 2 PSE drops its output voltage into the detection range during the classification sequence. The PD is required to have an incorrect detection signature in this condition, which is referred to as a mark event (see [Figure 19](#)). After the first mark event, the TPS2378 will present a signature less than 12 k Ω until it has experienced a $V_{(VDD-VSS)}$ voltage below the mark reset threshold (V_{MSR}). This is explained more fully under [Hardware Classification](#).

7.4.5 Hardware Classification

Hardware classification allows a PSE to determine a PD's power requirements before powering, and helps with power management once power is applied. Type 2 hardware classification permits high power PSEs and PDs to determine whether the connected device can support high-power operation. A type 2 PD presents class 4 in hardware to indicate that it is a high-power device. A type 1 PSE will treat a class 4 device like a class 0 device, allotting 13 W if it chooses to power the PD. A PD that receives a 2-event class understands that it is powered from a high-power PSE and it may draw up to 25.5 W immediately after the 80-ms start-up period completes. A type 2 PD that does not receive a 2-event hardware classification may choose to not start, or must start in a 13-W condition and request more power through the DLL after start-up. The standard requires a type 2 PD to indicate that it is underpowered if this occurs. Start-up of a high-power PD under 13 W implicitly requires some form of powering down sections of the application circuits.

The maximum power entries in [Table 1](#) determine the class the PD must advertise. The PSE may disconnect a PD if it draws more than its stated class power, which may be the hardware class or a lower DLL-derived power level. The standard permits the PD to draw limited current peaks that increase the instantaneous power above the [Table 1](#) limit; however, the average power requirement always applies.

The TPS2378 implements two-event classification. Selecting an R_{CLS} of 63.4 Ω provides a valid type 2 signature. TPS2378 may be used as a compatible type 1 device simply by programming class 0–3 per [Table 1](#). DLL communication is implemented by the Ethernet communication system in the PD and is not implemented by the TPS2378.

The TPS2378 disables classification above V_{CU_ON} to avoid excessive power dissipation. CLS voltage is turned off during PD thermal limiting or when APD or DEN is active. The CLS output is inherently current-limited, but should not be shorted to V_{SS} for long periods of time.

[Figure 20](#) shows how classification works for the TPS2378. Transition from state-to-state occurs when comparator thresholds are crossed (see [Figure 17](#) and [Figure 18](#)). These comparators have hysteresis, which adds inherent memory to the machine. Operation begins at idle (unpowered by PSE) and proceeds with increasing voltage from left to right. A 2-event classification follows the (heavy lined) path towards the bottom, ending up with a latched type 2 decode along the lower branch that is highlighted. This state results in a low T2P during normal operation. Once the valid path to type 2 PSE detection is broken, the input voltage must transition below the mark reset threshold to start anew.

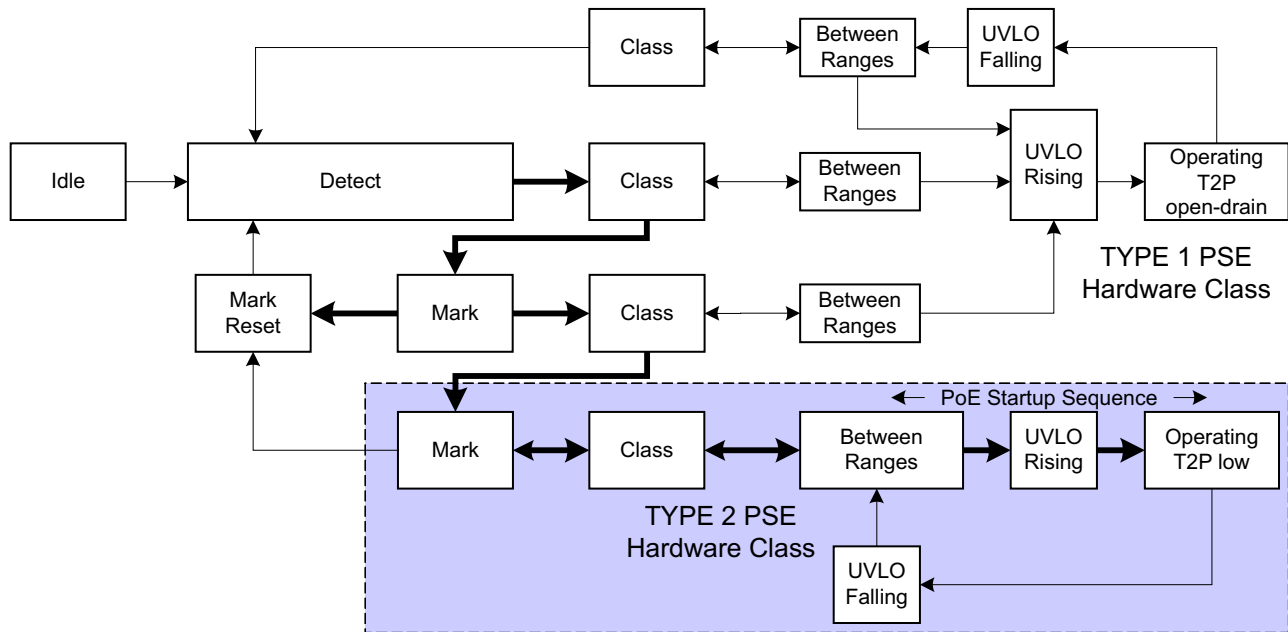

Figure 20. Two-Event Class Internal States

7.4.6 Inrush and Start-up

IEEE 802.3at has a start-up current and time limitation, providing type 2 PSE compatibility for type 1 PDs. A type 2 PSE limits output current to from 400 mA to 450 mA for up to 75 ms after power up (applying 48 V to the PI) to mirror type 1 PSE functionality. The type 2 PSE will support higher output current after 75 ms. The TPS2378 implements a 140-mA inrush current, which is compatible with all PSE types. A high-power PD must limit its converter start-up peak current. The operational current cannot exceed 400 mA for a period of 80 ms or longer. This requirement implicitly requires some form of powering down sections of the application circuits.

7.4.7 Maintain Power Signature

The MPS is an electrical signature presented by the PD to assure the PSE that it is still present after operating voltage is applied. A valid MPS consists of a minimum dc current of 10 mA (or a 10-mA pulsed current for at least 75 ms every 325 ms) and an AC impedance lower than 26.3 kΩ in parallel with 0.05 μF. The AC impedance is usually accomplished by the minimum operating C_{BULK} requirement of 5 μF. When either APD or DEN is used to force the hotswap switch off, the DC MPS will not be met. A PSE that monitors the DC MPS will remove power from the PD when this occurs. A PSE that monitors only the ac MPS may remove power from the PD.

7.4.8 Start-up and Converter Operation

The internal PoE UVLO (Undervoltage Lock Out) circuit holds the hotswap switch off before the PSE provides full voltage to the PD. This prevents the downstream converter circuits from loading the PoE input during detection and classification. The converter circuits will discharge C_{BULK} while the PD is unpowered. Thus $V_{(VDD-RTN)}$ will be a small voltage just after full voltage is applied to the PD, as seen in Figure 19. The PSE drives the PI voltage to the operating range once it has decided to power up the PD. When V_{VDD} rises above the UVLO turn-on threshold (V_{UVLO_R} , approximately 38 V) with RTN high, the TPS2378 enables the hotswap MOSFET with a approximately 140 mA (inrush) current limit as seen in Figure 21. The CDB pin is active while C_{BULK} charges and V_{RTN} falls from V_{VDD} to nearly V_{VSS} . Additional loading applied between V_{VDD} and V_{RTN} during the inrush state may prevent successful PD and subsequent converter start up. Once the inrush current falls about 10% below the inrush current limit, the PD current limit switches to the operational level (approximately 1000 mA) and CDB is deassert to allow downstream converter circuitry to start. In Figure 21, T2P is active when a type 2 PSE is plugged in.

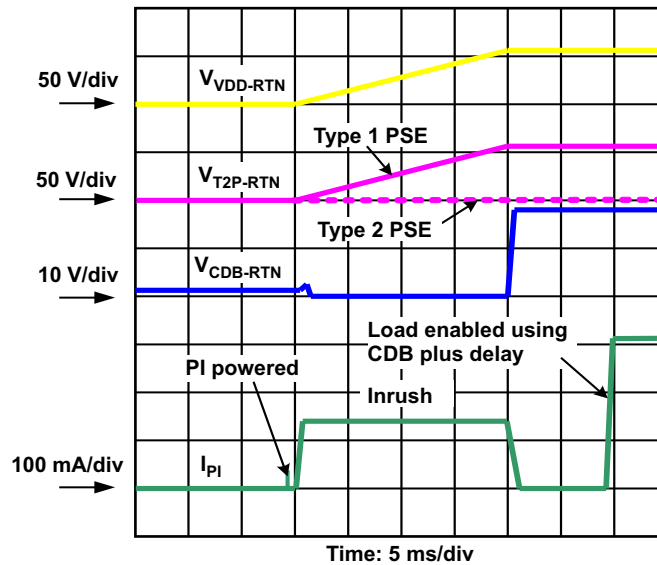

Figure 21. Power Up and Start

7.4.9 PD Hotswap Operation

IEEE 802.3at has taken a new approach to PSE output limiting. A type 2 PSE must meet an output current vs time template with specified minimum and maximum sourcing boundaries. The peak output current may be as high as 50 A for 10 μ s or 1.75 A for 75 ms. This makes robust protection of the PD device even more important than it was in IEEE 802.3-2008.

The internal hotswap MOSFET is protected against output faults and input voltage steps with a current limit and deglitched (time-delay filtered) foldback. An overload on the pass MOSFET engages the current limit, with $V_{(RTN-VSS)}$ rising as a result. If $V_{(RTN-VSS)}$ rises above approximately 12 V for longer than approximately 800 μ s, the current limit reverts to the inrush value. The 800- μ s deglitch feature prevents momentary transients from causing a PD reset, provided that recovery lies within the bounds of the hotswap and PSE protection. Figure 22 shows an example of the RTN current profile during V_{DD} to RTN short circuit. The hotswap MOSFET goes into current limit, causing the RTN voltage to increase. Once V_{RTN} exceeds 12 V, I_{RTN} , which was clamped to the current limit, drops to the level of inrush current limit after 800 μ s. The inrush current limit is reestablished when $V_{(VDD-VSS)}$ drops below UVLO.

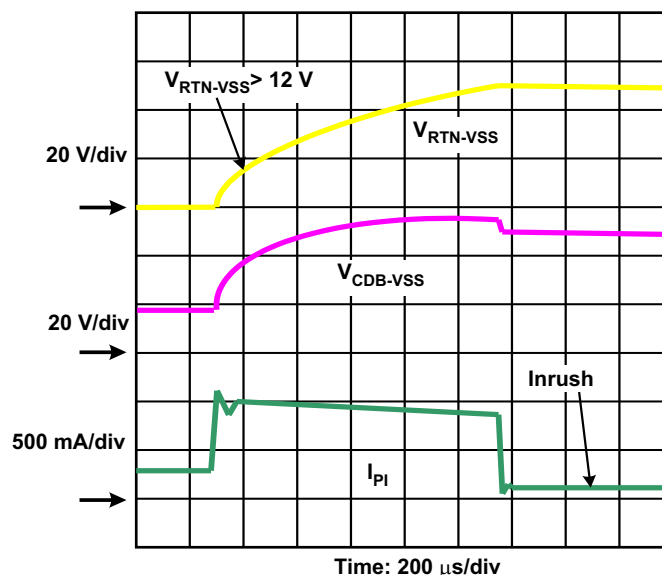

Figure 22. Response to PD Output Short Circuit

The PD control has a thermal sensor that protects the internal hotswap MOSFET. Conditions like start-up or operation into a V_{DD} -to-RTN short cause high power dissipation in the MOSFET. An over-temperature shutdown (OTSD) turns off the hotswap MOSFET and class regulator, which are restarted after the device cools. The hotswap MOSFET will be re-enabled with the inrush current limit when exiting from an overtemperature event. Pulling DEN to VSS during powered operation causes the internal hotswap MOSFET to turn off. This feature allows a PD with option three ORing per [Figure 23](#) to achieve adapter priority.

The hotswap switch will be forced off under the following conditions:

1. V_{APD} above V_{APDEN} (approximately 1.5 V),
2. $V_{(DEN-VSS)} < V_{PD-DIS}$ when $V_{(VDD-VSS)}$ is in the operational range,
3. PD is over-temperature, or
4. $V_{(DEN-VSS)} < \text{PoE UVLO falling threshold}$ (approximately 32 V).

7.4.10 Start-up and Power Management, CDB and T2P

CDB (converter disable) is an active-low pin that indicates when the internal hotswap MOSFET is in inrush limiting. CDB deasserts when inrush is over and can be used to enable a downstream converter to start up. Common interfaces to the converter controller include the soft start or enable pins.

T2P (type 2 PSE) is an active-low multifunction pin that indicates if

$[(\text{PSE} = \text{Type_2}) \text{ or } (1.5 \text{ V} < V_{APD})]$ and $(\text{pd current limit} \neq \text{Inrush})$.

The APD term allows the PD to operate from an adapter at high-power if a type 2 PSE is not present, assuming the adapter has sufficient capacity. Applications must monitor the state of T2P to detect power source transitions. Transitions could occur when a local power supply is added or dropped, or when a PSE is enabled on the far end. The PD may be required to adjust the load appropriately. The usage of T2P is demonstrated in [Figure 24](#).

In order for a type 2 PD to operate at less than 13 W for the first 80 ms after power application, the various delays must be estimated and used by the application controller to meet the requirement. The bootup time of many application processors may be long enough to eliminate the need for any timing.

7.4.11 Adapter ORing

Many PoE-capable devices are designed to operate from either a wall adapter or PoE power. A local power solution adds cost and complexity, but allows a product to be used if PoE is not available in a particular installation. While most applications only require that the PD operate when both sources are present, the TPS2378 supports forced operation from either of the power sources. [Figure 23](#) illustrates three options for diode ORing external power into a PD. Only one option would be used in any particular design. Option 1 applies power to the TPS2378 PoE input, option 2 applies power between the TPS2378 PoE section and the power circuit, and option 3 applies power to the output side of the converter. Each of these options has advantages and disadvantages. Many of the basic ORing configurations and much of the discussion contained in the application note *Advanced Adapter ORing Solutions* using the TPS23753 ([SLVA306](#)), apply to the TPS2378 incorporating a DC/DC converter.

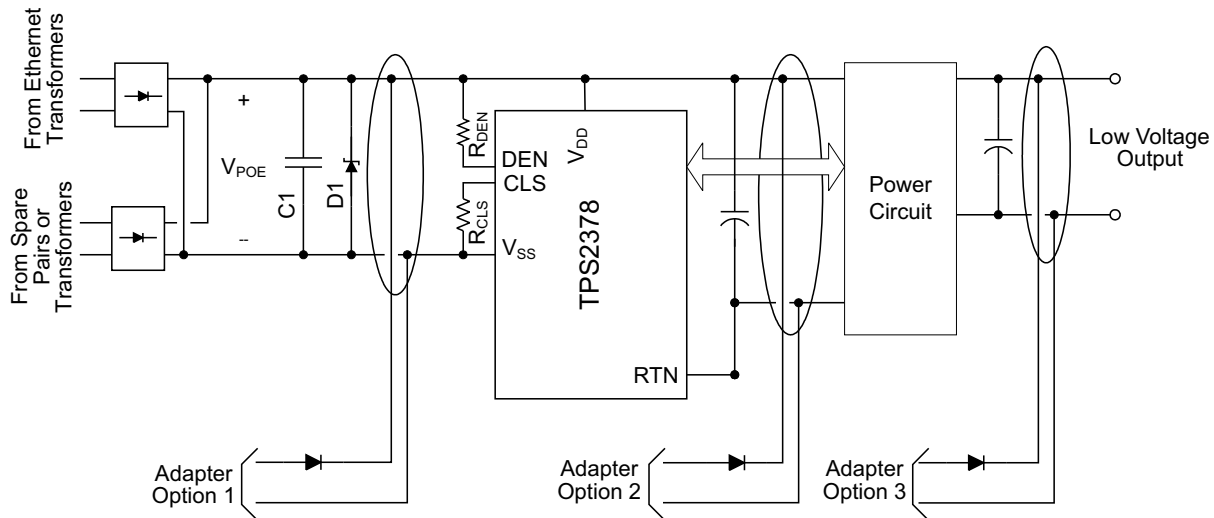
Figure 23. ORing Configurations

The IEEE standards require that the Ethernet cable be isolated from ground and all other system potentials. The adapter must meet a minimum 1500 Vac dielectric withstand test between the output and all other connections for ORing options 1 and 2. The adapter only needs this isolation for option 3 if it is not provided by the converter.

Adapter ORing diodes are shown for all the options to protect against a reverse voltage adapter, a short on the adapter input pins, or damage to a low-voltage adapter. ORing is sometimes accomplished with a MOSFET in option 3.

7.4.12 Using DEN to Disable PoE

The DEN pin may be used to turn the PoE hotswap switch off by pulling it to V_{SS} while in the operational state, or to prevent detection when in the idle state. A low voltage on DEN forces the hotswap MOSFET off during normal operation. Additional information is available in the *Advanced Adapter ORing Solutions using the TPS23753 (SLVA306)* application report.

7.4.13 ORing Challenges

Preference of one power source presents a number of challenges. Combinations of adapter output voltage (nominal and tolerance), power insertion point, and which source is preferred determine solution complexity. Several factors adding to the complexity are the natural high-voltage selection of diode ORing (the simplest method of combining sources), the current limit implicit in the PSE, and PD inrush and protection circuits (necessary for operation and reliability). Creating simple and seamless solutions is difficult, if not impossible, for many of the combinations. However, the TPS2378 offers several built-in features that simplify some combinations.

Several examples demonstrate the limitations inherent in ORing solutions. Diode ORing a 48-V adapter with PoE (option 1) presents the problem that either source may have the higher voltage. A blocking switch would be required to assure that one source dominates. A second example combines a 12-V adapter with PoE using option 2. The converter draws approximately four times the current at 12 V from the adapter than it does from PoE at 48 V. Transition from PoE power to adapter may demand more current than can be supplied by the PSE. The converter must be turned off while the C_{BULK} capacitance charges, with a subsequent converter restart at the higher voltage and lower input current. A third example involves the loss of the MPS when running from the adapter, causing the PSE to remove power from the PD. If AC power is then lost, the PD will stop operating until the PSE detects and powers the PD.

8 Application and Implementation

NOTE

Information in the following applications sections is not part of the TI component specification, and TI does not warrant its accuracy or completeness. TI's customers are responsible for determining suitability of components for their purposes. Customers should validate and test their design implementation to confirm system functionality.

8.1 Application Information

The TPS2378 has the flexibility to be implemented in IEEE802.3at and Universal Power Over Ethernet (UPOE) PDs. Therefore, it can be used in a wide range applications such as video and VoIP telephones, multiband access points, security cameras, and pico-base stations.

8.2 Typical Application

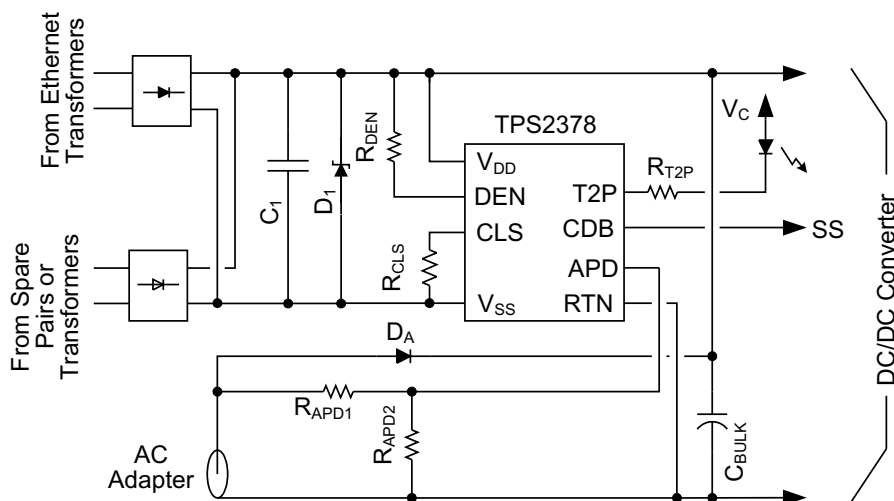

Figure 24. Typical Application Circuit

8.2.1 Design Requirements

For this design example, use the parameters in [Table 3](#).

Table 3. Design Parameters

PARAMETER	TEST CONDITIONS	MIN	MAX	UNIT
POWER INTERFACE				
Input voltage	Applied to the power pins of connectors J1 or J3 (adapter)	0	57	V
Operating voltage	After start-up	30	57	V
Input UVLO	Rising input voltage at device terminals	—	40	V
	Falling input voltage	30.5	—	
Detection voltage	At device terminals	1.4	10.1	V
Classification voltage	At device terminals	11.9	23	V
Classification current	Class 4	38	42	mA
Inrush current limit		100	180	mA
Operating current-limit		850	1200	mA

8.2.2 Detailed Design Requirements

8.2.2.1 Input Bridges and Schottky Diodes

Using Schottky diodes instead of PN junction diodes for the PoE input bridges will reduce the power dissipation in these devices by about 30%. There are, however, some things to consider when using them. The IEEE standard specifies a maximum backfeed voltage of 2.8 V. A 100-kΩ resistor is placed between the unpowered pairs and the voltage is measured across the resistor. Schottky diodes often have a higher reverse leakage current than PN diodes, making this a harder requirement to meet. To compensate, use conservative design for diode operating temperature, select lower-leakage devices where possible, and match leakage and temperatures by using packaged bridges.

Schottky diode leakage currents and lower dynamic resistances can impact the detection signature. Setting reasonable expectations for the temperature range over which the detection signature is accurate is the simplest solution. Increasing R_{DEN} slightly may also help meet the requirement.

Schottky diodes have proven less robust to the stresses of ESD transients than PN junction diodes. After exposure to ESD, Schottky diodes may become shorted or leak. Take care to provide adequate protection in line with the exposure levels. This protection may be as simple as ferrite beads and capacitors.

As a general recommendation, use 1 A or 2 A, 100 V rated discrete or bridge diodes for the input rectifiers.

8.2.2.2 Protection, D_1

A TVS, D_1 , across the rectified PoE voltage per [Figure 24](#) must be used. TI recommends a SMAJ58A, or equivalent, is recommended for general indoor applications. If an adapter is connected from V_{DD} to RTN, as in ORing option 2 above, then voltage transients caused by the input cable inductance ringing with the internal PD capacitance can occur. Adequate capacitive filtering or a TVS must limit this voltage to within the absolute maximum ratings. Outdoor transient levels or special applications require additional protection.

8.2.2.3 Capacitor, C_1

The IEEE 802.3at standard specifies an input bypass capacitor (from V_{DD} to V_{SS}) of 0.05 μF to 0.12 μF. Typically a 0.1 μF, 100 V, 10% ceramic capacitor is used.

8.2.2.4 Detection Resistor, R_{DEN}

The IEEE 802.3at standard specifies a detection signature resistance, R_{DEN} between 23.7 kΩ and 26.3 kΩ, or 25 kΩ ± 5%. A resistor of 24.9 kΩ ± 1% is recommended for R_{DEN} .

8.2.2.5 Classification Resistor, R_{CLS}

Connect a resistor from CLS to V_{SS} to program the classification current according to the IEEE 802.3at standard. The class power assigned should correspond to the maximum average power drawn by the PD during operation. Select R_{CLS} according to [Table 1](#).

Choose class 4 and $R_{CLS} = 63.4 \Omega$.

8.2.2.6 APD Pin Divider Network RAPD1, RAPD2

For an adapter voltage threshold to switch from PoE to adapter at 37 V, choose 10 kΩ for RAPD2.

$$\frac{V_{\text{Adapter}} R_{\text{APD2}}}{R_{\text{APD1}} + R_{\text{APD2}}} = 1.5 \text{ V} \quad (3)$$

$$\frac{37 \text{ V} \times 10 \text{ k}}{10 \text{ k} + R_{\text{APD1}}} = 1.5 \text{ V} \quad (4)$$

Solving for RAPD1:

$$RAPD1 = 237 \text{ k}\Omega \quad (5)$$

8.2.3 Application Curves

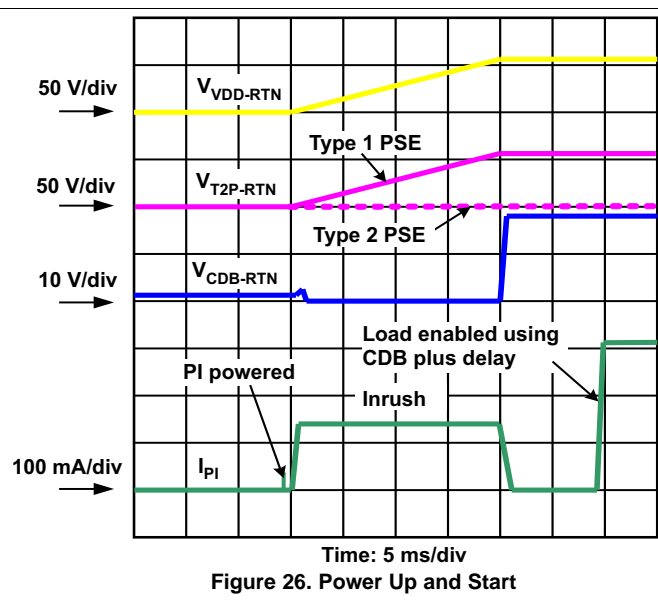
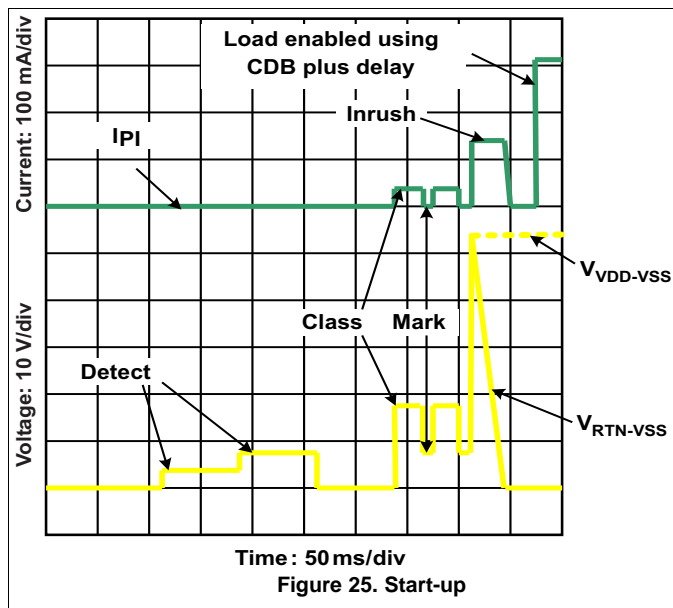

9 Power Supply Recommendations

The TPS2378 device will typically be followed by a power supply such as an isolated flyback or active clamp forward converter or a non-isolated buck converter. The input voltage of the converter should be capable of operating within the IEEE802.3at recommended input voltage as shown in [Table 2](#).

10 Layout

10.1 Layout Guidelines

The layout of the PoE front end should follow power and EMI/ESD best practice guidelines. A basic set of recommendations include:

- Parts placement must be driven by power flow in a point-to-point manner; RJ-45, Ethernet transformer, diode bridges, TVS and 0.1- μ F capacitor, and TPS2378.
- All leads should be as short as possible with wide power traces and paired signal and return.
- There should not be any crossovers of signals from one part of the flow to another.
- Spacing consistent with safety standards like IEC60950 must be observed between the 48-V input voltage rails and between the input and an isolated converter output.
- The TPS2378 should be located over split, local ground planes referenced to VSS for the PoE input and to RTN for the switched output.
- Large copper fills and traces should be used on SMT power-dissipating devices, and wide traces or overlay copper fills should be used in the power path.

10.2 Layout Example

[Figure 27](#) and [Figure 28](#) show the top and bottom layer and assemblies of the TPS2378EVM-105 as a reference for optimum parts placement. A detailed PCB layout can be found in the user's guide of the TPS2378EVM-105 ([SLVU682](#)).

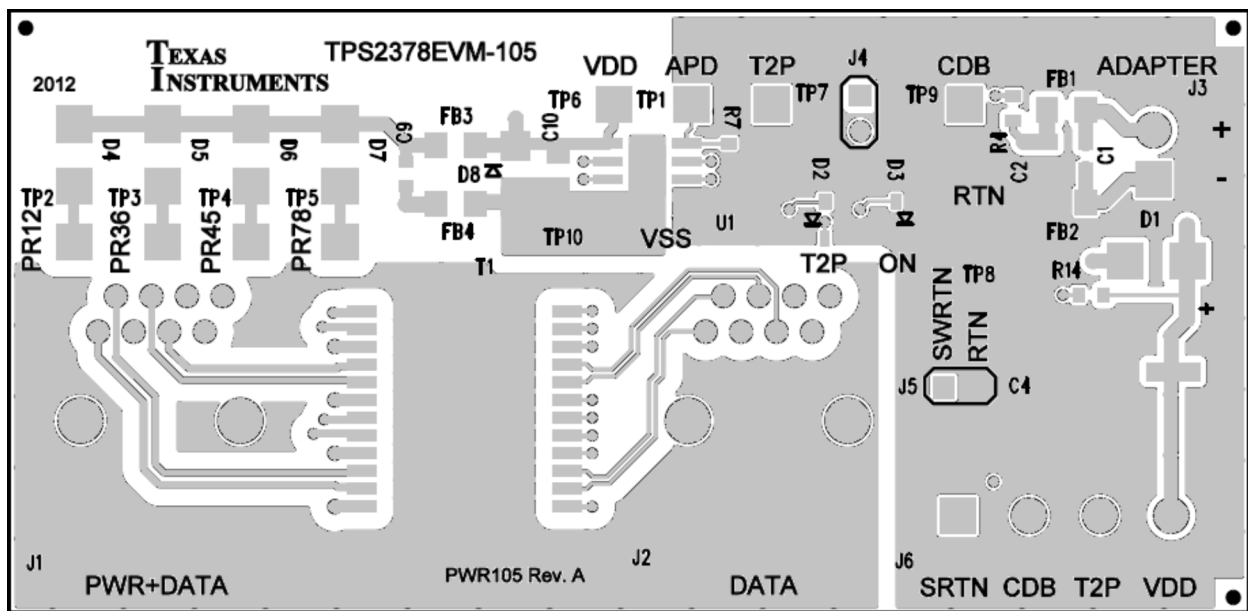

Figure 27. Top Side

Layout Example (continued)

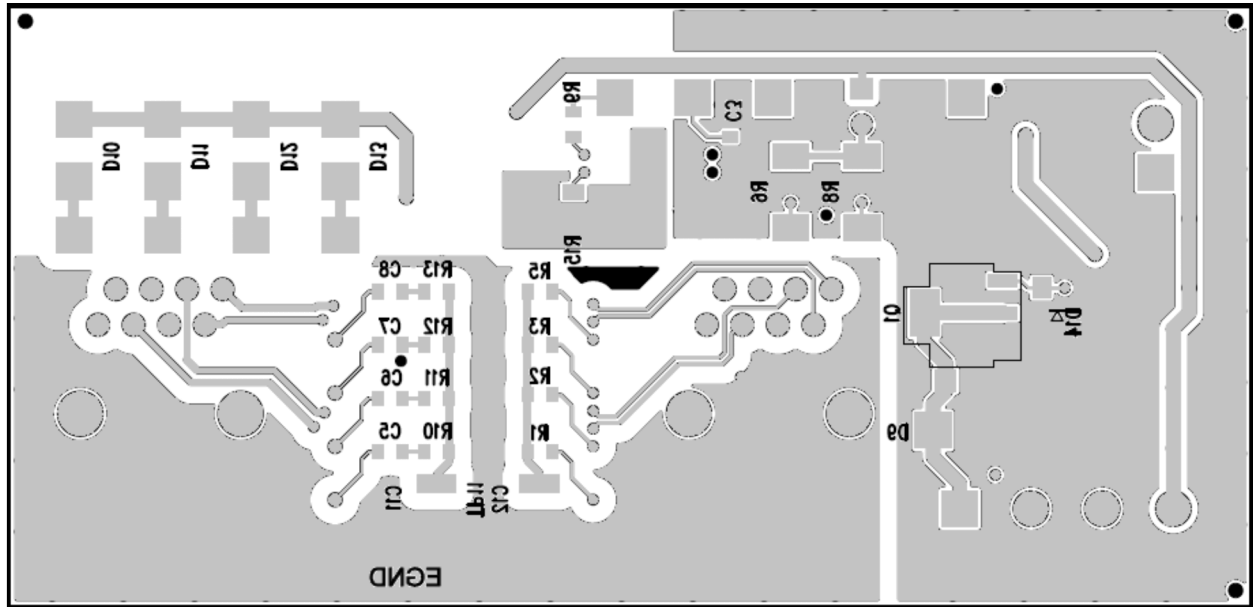

Figure 28. Bottom Side

10.3 EMI Containment

- Use compact loops for dv/dt and di/dt circuit paths (power loops and gate drives).
- Use minimal, yet thermally adequate, copper areas for heat sinking of components tied to switching nodes (minimize exposed radiating surface).
- Use copper ground planes (possible stitching) and top layer copper floods (surround circuitry with ground floods).
- Use 4 layer PCB if economically feasible (for better grounding).
- Minimize the amount of copper area associated with input traces (to minimize radiated pickup).
- Use Bob Smith terminations, Bob Smith EFT capacitor, and Bob Smith plane.
- Use Bob Smith plane as ground shield on input side of PCB (creating a phantom or literal earth ground).
- Use of ferrite beads on input (allow for possible use of beads or 0 ohm resistors).
- Maintain physical separation between input-related circuitry and power circuitry (use ferrite beads as boundary line).
- Possible use of common-mode inductors.
- Possible use of integrated RJ-45 jacks (shielded with internal transformer and Bob Smith terminations).
- End-product enclosure considerations (shielding).

10.4 Thermal Considerations and OTSD

Sources of nearby local PCB heating should be considered during the thermal design. Typical calculations assume that the TPS2378 is the only heat source contributing to the PCB temperature rise. It is possible for a normally operating TPS2378 device to experience an OTSD event if it is excessively heated by a nearby device.

10.5 ESD

ESD requirements for a unit that incorporates the TPS2378 have a much broader scope and operational implications than are used in TI's testing. Unit-level requirements should not be confused with reference design testing that only validates the ruggedness of the TPS2378.

11 Device and Documentation Support

11.1 Documentation Support

11.1.1 Related Documentation

For related documentation see the following:

- *Advanced Adapter ORing Solutions using the TPS23753*, [SLVA306](#)

11.2 Community Resources

The following links connect to TI community resources. Linked contents are provided "AS IS" by the respective contributors. They do not constitute TI specifications and do not necessarily reflect TI's views; see TI's [Terms of Use](#).

TI E2E™ Online Community *TI's Engineer-to-Engineer (E2E) Community*. Created to foster collaboration among engineers. At [e2e.ti.com](#), you can ask questions, share knowledge, explore ideas and help solve problems with fellow engineers.

Design Support *TI's Design Support* Quickly find helpful E2E forums along with design support tools and contact information for technical support.

11.3 Trademarks

PowerPAD, E2E are trademarks of Texas Instruments. All other trademarks are the property of their respective owners.

11.4 Electrostatic Discharge Caution



These devices have limited built-in ESD protection. The leads should be shorted together or the device placed in conductive foam during storage or handling to prevent electrostatic damage to the MOS gates.

11.5 Glossary

[SLYZ022](#) — *TI Glossary*.

This glossary lists and explains terms, acronyms, and definitions.

12 Mechanical, Packaging, and Orderable Information

The following pages include mechanical, packaging, and orderable information. This information is the most current data available for the designated devices. This data is subject to change without notice and revision of this document. For browser-based versions of this data sheet, refer to the left-hand navigation.

PACKAGING INFORMATION

Orderable Device	Status (1)	Package Type	Package Drawing	Pins	Package Qty	Eco Plan (2)	Lead/Ball Finish (6)	MSL Peak Temp (3)	Op Temp (°C)	Device Marking (4/5)	Samples
TPS2378DDA	ACTIVE	SO PowerPAD	DDA	8	75	Green (RoHS & no Sb/Br)	CU NIPDAUAG	Level-2-260C-1 YEAR	-40 to 85	2378	Samples
TPS2378DDAR	ACTIVE	SO PowerPAD	DDA	8	2500	Green (RoHS & no Sb/Br)	CU NIPDAUAG	Level-2-260C-1 YEAR	-40 to 85	2378	Samples

(1) The marketing status values are defined as follows:

ACTIVE: Product device recommended for new designs.

LIFEBUY: TI has announced that the device will be discontinued, and a lifetime-buy period is in effect.

NRND: Not recommended for new designs. Device is in production to support existing customers, but TI does not recommend using this part in a new design.

PREVIEW: Device has been announced but is not in production. Samples may or may not be available.

OBSOLETE: TI has discontinued the production of the device.

(2) Eco Plan - The planned eco-friendly classification: Pb-Free (RoHS), Pb-Free (RoHS Exempt), or Green (RoHS & no Sb/Br) - please check <http://www.ti.com/productcontent> for the latest availability information and additional product content details.

TBD: The Pb-Free/Green conversion plan has not been defined.

Pb-Free (RoHS): TI's terms "Lead-Free" or "Pb-Free" mean semiconductor products that are compatible with the current RoHS requirements for all 6 substances, including the requirement that lead not exceed 0.1% by weight in homogeneous materials. Where designed to be soldered at high temperatures, TI Pb-Free products are suitable for use in specified lead-free processes.

Pb-Free (RoHS Exempt): This component has a RoHS exemption for either 1) lead-based flip-chip solder bumps used between the die and package, or 2) lead-based die adhesive used between the die and leadframe. The component is otherwise considered Pb-Free (RoHS compatible) as defined above.

Green (RoHS & no Sb/Br): TI defines "Green" to mean Pb-Free (RoHS compatible), and free of Bromine (Br) and Antimony (Sb) based flame retardants (Br or Sb do not exceed 0.1% by weight in homogeneous material)

(3) MSL, Peak Temp. - The Moisture Sensitivity Level rating according to the JEDEC industry standard classifications, and peak solder temperature.

(4) There may be additional marking, which relates to the logo, the lot trace code information, or the environmental category on the device.

(5) Multiple Device Markings will be inside parentheses. Only one Device Marking contained in parentheses and separated by a "~" will appear on a device. If a line is indented then it is a continuation of the previous line and the two combined represent the entire Device Marking for that device.

(6) Lead/Ball Finish - Orderable Devices may have multiple material finish options. Finish options are separated by a vertical ruled line. Lead/Ball Finish values may wrap to two lines if the finish value exceeds the maximum column width.

Important Information and Disclaimer: The information provided on this page represents TI's knowledge and belief as of the date that it is provided. TI bases its knowledge and belief on information provided by third parties, and makes no representation or warranty as to the accuracy of such information. Efforts are underway to better integrate information from third parties. TI has taken and continues to take reasonable steps to provide representative and accurate information but may not have conducted destructive testing or chemical analysis on incoming materials and chemicals. TI and TI suppliers consider certain information to be proprietary, and thus CAS numbers and other limited information may not be available for release.

In no event shall TI's liability arising out of such information exceed the total purchase price of the TI part(s) at issue in this document sold by TI to Customer on an annual basis.

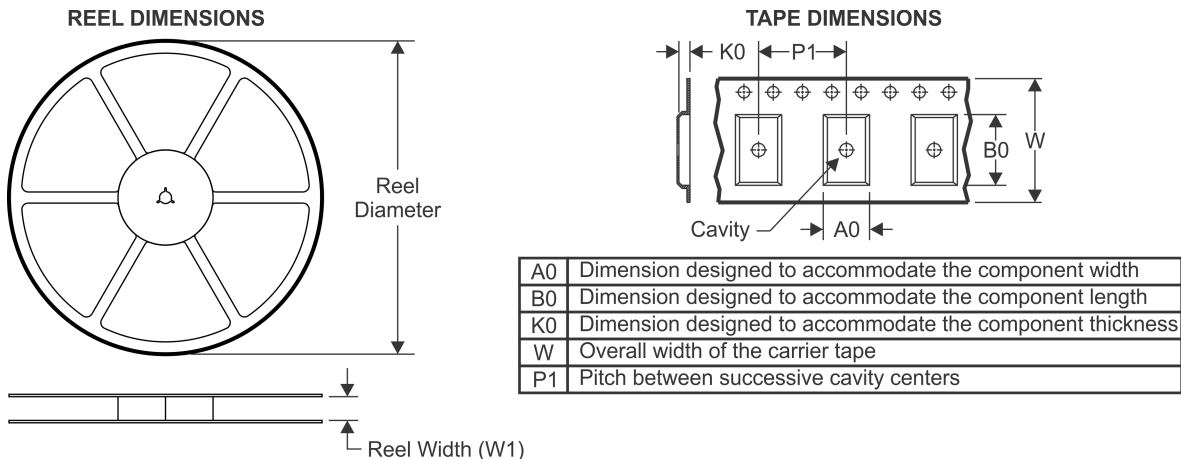
TAPE AND REEL INFORMATION

QUADRANT ASSIGNMENTS FOR PIN 1 ORIENTATION IN TAPE



*All dimensions are nominal

Device	Package Type	Package Drawing	Pins	SPQ	Reel Diameter (mm)	Reel Width W1 (mm)	A0 (mm)	B0 (mm)	K0 (mm)	P1 (mm)	W (mm)	Pin1 Quadrant
TPS2378DDAR	SO Power PAD	DDA	8	2500	330.0	12.8	6.4	5.2	2.1	8.0	12.0	Q1

TAPE AND REEL BOX DIMENSIONS

*All dimensions are nominal

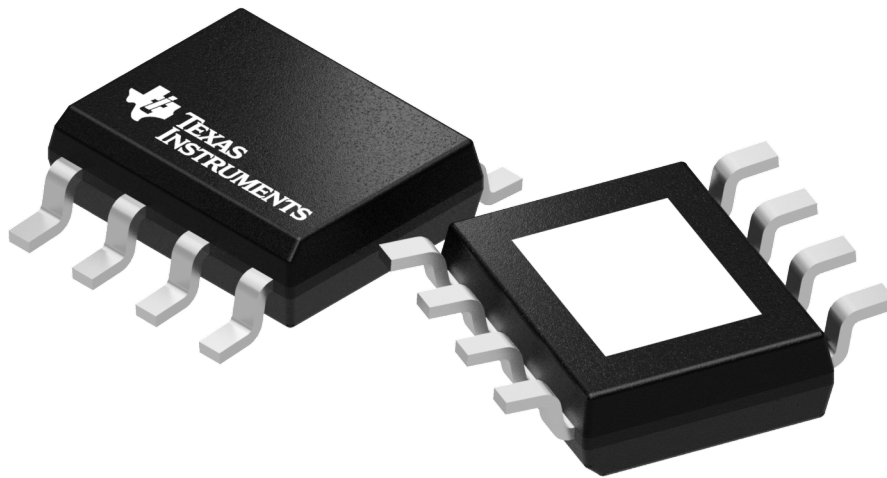
Device	Package Type	Package Drawing	Pins	SPQ	Length (mm)	Width (mm)	Height (mm)
TPS2378DDAR	SO PowerPAD	DDA	8	2500	366.0	364.0	50.0



Images above are just a representation of the package family, actual package may vary.
Refer to the product data sheet for package details.

DDA (R-PDSO-G8)

PowerPAD™ PLASTIC SMALL-OUTLINE

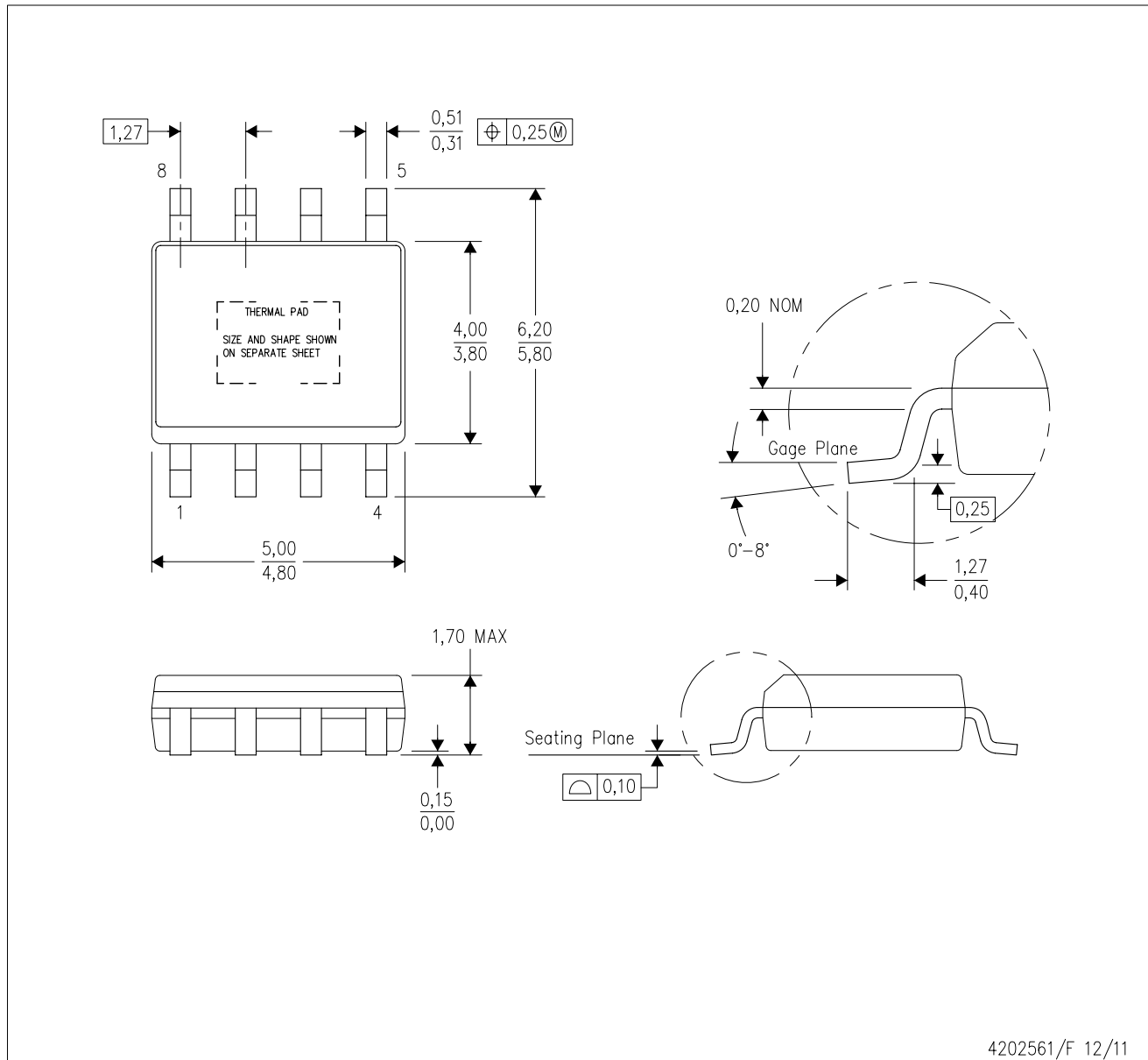

4202561/F 12/11

- NOTES:
- All linear dimensions are in millimeters. Dimensioning and tolerancing per ASME Y14.5-1994.
 - This drawing is subject to change without notice.
 - Body dimensions do not include mold flash or protrusion not to exceed 0,15.
 - This package is designed to be soldered to a thermal pad on the board. Refer to Technical Brief, PowerPad Thermally Enhanced Package, Texas Instruments Literature No. SLMA002 for information regarding recommended board layout. This document is available at www.ti.com <<http://www.ti.com>>.
 - See the additional figure in the Product Data Sheet for details regarding the exposed thermal pad features and dimensions.
 - This package complies to JEDEC MS-012 variation BA

PowerPAD is a trademark of Texas Instruments.

DDA (R-PDSO-G8)

PowerPAD™ PLASTIC SMALL OUTLINE

THERMAL INFORMATION

This PowerPAD™ package incorporates an exposed thermal pad that is designed to be attached to a printed circuit board (PCB). The thermal pad must be soldered directly to the PCB. After soldering, the PCB can be used as a heatsink. In addition, through the use of thermal vias, the thermal pad can be attached directly to the appropriate copper plane shown in the electrical schematic for the device, or alternatively, can be attached to a special heatsink structure designed into the PCB. This design optimizes the heat transfer from the integrated circuit (IC).

For additional information on the PowerPAD package and how to take advantage of its heat dissipating abilities, refer to Technical Brief, PowerPAD Thermally Enhanced Package, Texas Instruments Literature No. SLMA002 and Application Brief, PowerPAD Made Easy, Texas Instruments Literature No. SLMA004. Both documents are available at www.ti.com.

The exposed thermal pad dimensions for this package are shown in the following illustration.

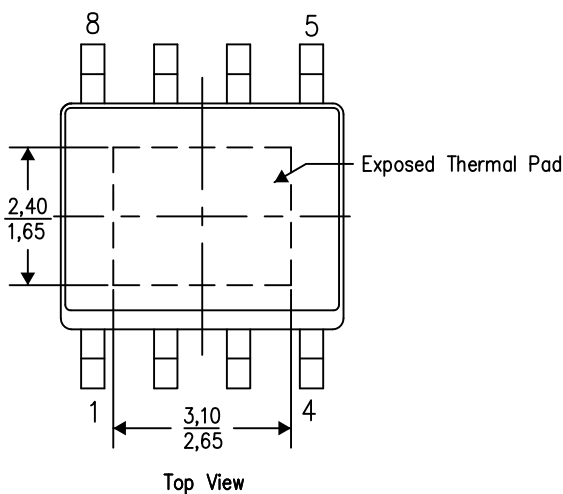

Exposed Thermal Pad Dimensions

4206322-6/L 05/12

NOTE: A. All linear dimensions are in millimeters

PowerPAD is a trademark of Texas Instruments

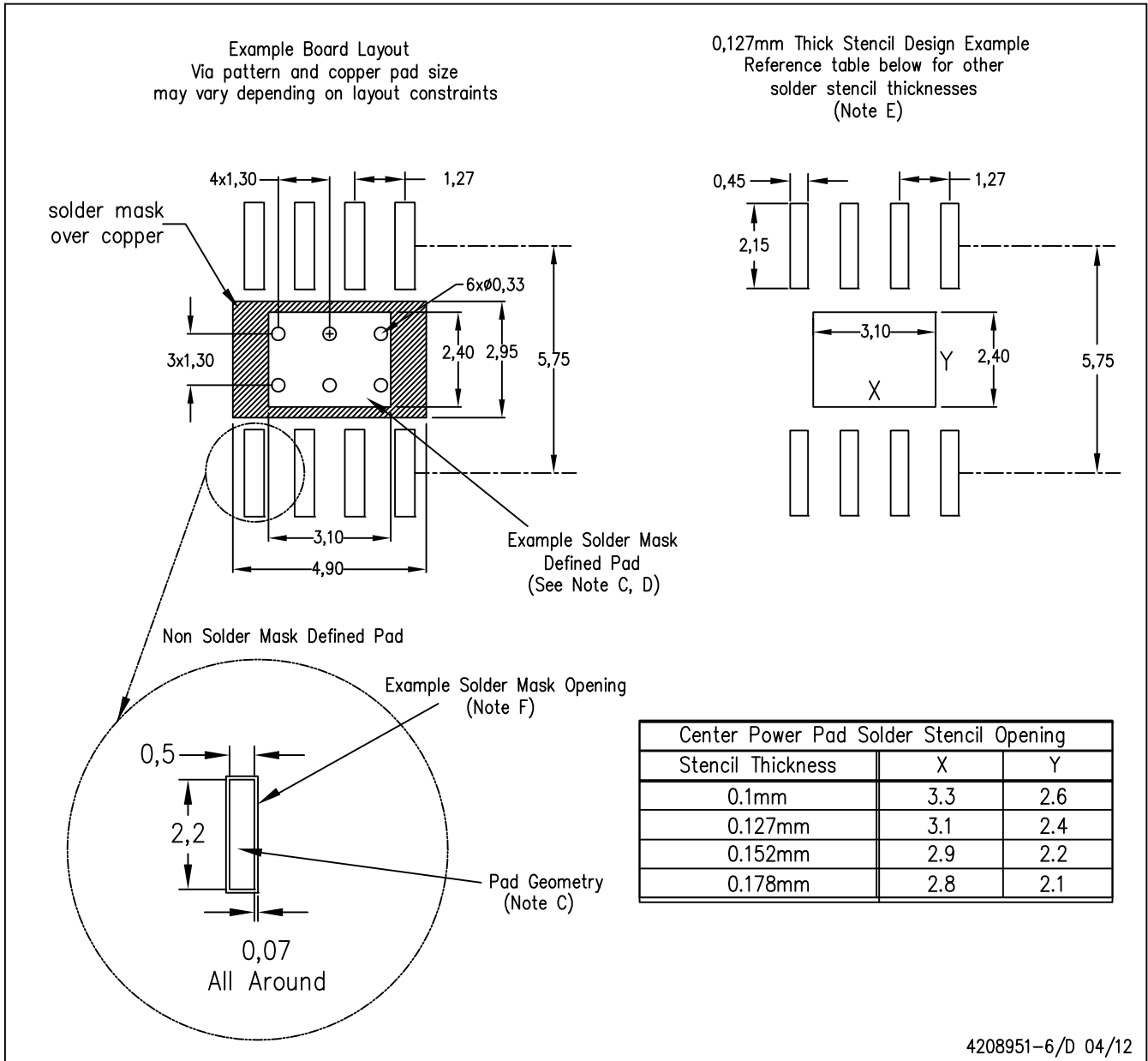

- NOTES:
- A. All linear dimensions are in millimeters.
 - B. This drawing is subject to change without notice.
 - C. Publication IPC-7351 is recommended for alternate designs.
 - D. This package is designed to be soldered to a thermal pad on the board. Refer to Technical Brief, PowerPad Thermally Enhanced Package, Texas Instruments Literature No. SLMA002, SLMA004, and also the Product Data Sheets for specific thermal information, via requirements, and recommended board layout. These documents are available at www.ti.com <<http://www.ti.com>>. Publication IPC-7351 is recommended for alternate designs.
 - E. Laser cutting apertures with trapezoidal walls and also rounding corners will offer better paste release. Customers should contact their board assembly site for stencil design recommendations. Example stencil design based on a 50% volumetric metal load solder paste. Refer to IPC-7525 for other stencil recommendations.
 - F. Customers should contact their board fabrication site for solder mask tolerances between and around signal pads.

PowerPAD is a trademark of Texas Instruments.

IMPORTANT NOTICE AND DISCLAIMER

TI PROVIDES TECHNICAL AND RELIABILITY DATA (INCLUDING DATASHEETS), DESIGN RESOURCES (INCLUDING REFERENCE DESIGNS), APPLICATION OR OTHER DESIGN ADVICE, WEB TOOLS, SAFETY INFORMATION, AND OTHER RESOURCES "AS IS" AND WITH ALL FAULTS, AND DISCLAIMS ALL WARRANTIES, EXPRESS AND IMPLIED, INCLUDING WITHOUT LIMITATION ANY IMPLIED WARRANTIES OF MERCHANTABILITY, FITNESS FOR A PARTICULAR PURPOSE OR NON-INFRINGEMENT OF THIRD PARTY INTELLECTUAL PROPERTY RIGHTS.

These resources are intended for skilled developers designing with TI products. You are solely responsible for (1) selecting the appropriate TI products for your application, (2) designing, validating and testing your application, and (3) ensuring your application meets applicable standards, and any other safety, security, or other requirements. These resources are subject to change without notice. TI grants you permission to use these resources only for development of an application that uses the TI products described in the resource. Other reproduction and display of these resources is prohibited. No license is granted to any other TI intellectual property right or to any third party intellectual property right. TI disclaims responsibility for, and you will fully indemnify TI and its representatives against, any claims, damages, costs, losses, and liabilities arising out of your use of these resources.

TI's products are provided subject to TI's Terms of Sale (www.ti.com/legal/termsofsale.html) or other applicable terms available either on ti.com or provided in conjunction with such TI products. TI's provision of these resources does not expand or otherwise alter TI's applicable warranties or warranty disclaimers for TI products.

Mailing Address: Texas Instruments, Post Office Box 655303, Dallas, Texas 75265
Copyright © 2019, Texas Instruments Incorporated

Looking for pricing, stock, or lifecycle information?

Click below to explore more details on WIN SOURCE:

 [View TPS2378DDAR](#) on WIN SOURCE

 [Texas Instruments](#) Information

Optimize Your Supply Chain with WIN SOURCE Solutions

-  Global Sourcing Solution
-  Obsolete Management
-  Cost Control Management
-  Shortage Management
-  Alternative Solution
-  Excess Inventory Management