



THE DATASHEET OF TPS23757PWR



High Efficiency PoE Interface and DC/DC Controller

FEATURES

- Powers up to 13 W (Input) PDs
- Legacy and IEEE 802.3at Type 1 PDs
- Optimized for Isolated DC/DC Converters
- Supports High-Efficiency Topologies
- Complete PoE Interface
- Adapter ORing Support
- Programmable Frequency with Synch.
- Robust 100 V, 0.5 Ω Hotswap MOSFET
- Pin Compatible with TPS23754/6
- -40°C to 125°C Junction Temperature Range
- Industry Standard TSSOP-20

APPLICATIONS

- IEEE 802.3at Type 1 Compliant Devices
- Video and VoIP Telephones
- Access Points
- Security Cameras

DESCRIPTION

The TPS23757 is a combined Power over Ethernet (PoE) powered device (PD) interface and current-mode dc/dc controller optimized specifically for isolated converters. The PoE interface supports the IEEE 802.3at standard for a type 1 PD, which is equivalent to the 13W standard of IEEE 802.3-2008.

The TPS23757 supports a number of input voltage ORing options including highest voltage, external adapter preference, and PoE preference.

The TPS23757 has an output flag indicating if an external wall adapter is active when used in conjunction with ORing controls. The detection signature pin can also be used to force power from the PoE source off. Classification can be programmed to any of the defined types with a single resistor.

The dc/dc controller features two complementary gate drivers with programmable dead time. This simplifies design of highly-efficient flyback topologies or active-clamp forward or flyback converters. The second gate driver may be disabled if desired for single MOSFET topologies. The controller also features internal softstart, bootstrap startup source, current-mode compensation, and a 78% maximum duty cycle. A programmable and synchronizable oscillator allows design optimization for efficiency and eases use of the controller to upgrade existing power supply designs. Accurate programmable blanking, with a default period, simplifies the usual current-sense filter design trade-offs.

The TPS23757 has a 9 V converter startup, permitting operation with 12 V wall adapters.

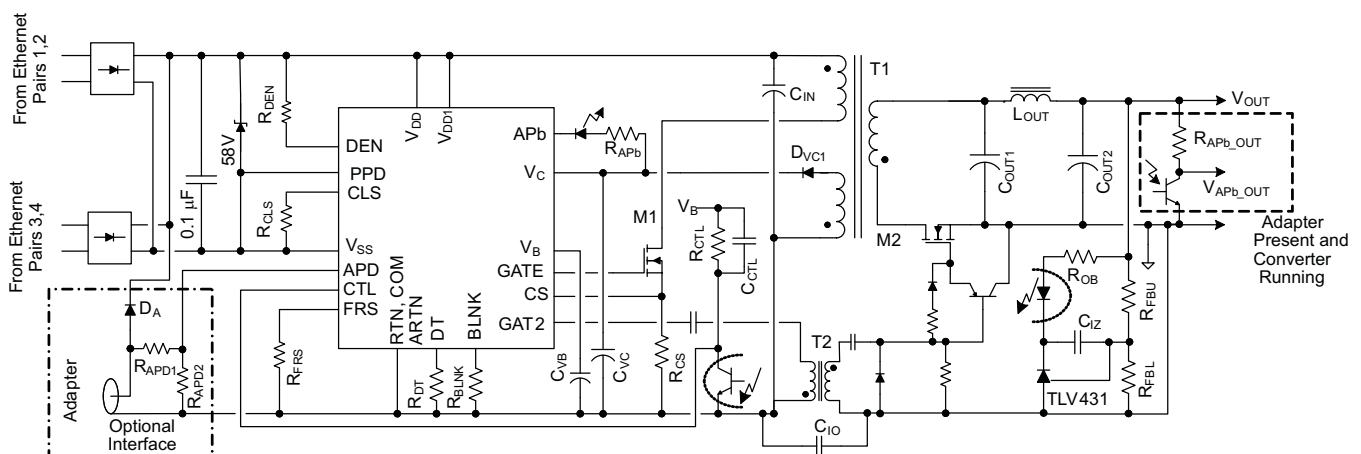

Figure 1. High Efficiency Converter Using TPS23757



Please be aware that an important notice concerning availability, standard warranty, and use in critical applications of Texas Instruments semiconductor products and disclaimers thereto appears at the end of this data sheet.

TPS23757

SLVS948D – JULY 2009 – REVISED NOVEMBER 2013

www.ti.com



This integrated circuit can be damaged by ESD. Texas Instruments recommends that all integrated circuits be handled with appropriate precautions. Failure to observe proper handling and installation procedures can cause damage.

ESD damage can range from subtle performance degradation to complete device failure. Precision integrated circuits may be more susceptible to damage because very small parametric changes could cause the device not to meet its published specifications.

PRODUCT INFORMATION⁽¹⁾

	STATUS	DUTY CYCLE	POE UVLO ON / HYST. (V)	CONVERTER UVLO ON / HYST. (V)	PoE Current Limit (mA)	PACKAGE	MARKING
TPS23757PW	Preview	0–78%	35/4.5	9 / 3.5	465	TSSOP-20	TPS23757

(1) For the most current package and ordering information, see the Package Option Addendum at the end of this document, or see the TI web site at www.ti.com.

ABSOLUTE MAXIMUM RATINGS^{(1) (2)}

Voltage with respect to V_{SS} unless otherwise noted.

		MIN	MAX	UNIT
Input voltage	ARTN ⁽²⁾ , COM ⁽²⁾ , DEN, PPD, RTN ⁽³⁾ , V_{DD} , V_{DD1}	–0.3	100	V
	CLS ⁽⁴⁾	–0.3	6.5	V
	[APD, BLNK ⁽⁴⁾ , CTL, DT ⁽⁴⁾ , FRS ⁽⁴⁾ , VB ⁽⁴⁾] to [ARTN, COM]	–0.3	6.5	V
	CS to [ARTN, COM]	–0.3	V_B	V
	[ARTN, COM] to RTN	–2	2	V
	V_C , APb, to [ARTN, COM]	–0.3	19	V
	GATE ⁽⁴⁾ , GAT2 ⁽⁴⁾ to [ARTN, COM]	–0.3	$V_C+0.3$	V
Sinking current	RTN	Internally limited		mA
Sourcing current	V_B	Internally limited		mA
Average Sourcing or sinking current	GATE, GAT2		25	mArms
Electrostatic Discharge	Human Body Model (HBM)		2	kV
	Charge Device Model (CDM)		500	V
	System level (contact/air) at RJ-45 ⁽⁵⁾		8 / 15	kV
Operating junction temperature range	T_J	–40	Internally limited	°C

- (1) Stresses beyond those listed under *absolute maximum ratings* may cause permanent damage to the device. These are stress ratings only and functional operation of the device at these or any other conditions beyond those indicated under *recommended operating conditions* is not implied. Exposure to absolute-maximum-rated conditions for extended periods may affect device reliability.
- (2) ARTN and COM typically tied to RTN.
- (3) $I_{RTN} = 0$ for $V_{RTN} > 80V$.
- (4) Do not apply voltage to these pins
- (5) ESD per EN61000-4-2. A power supply containing the TPS23757 was subjected to the highest test levels in the standard. See the ESD section.

RECOMMENDED OPERATING CONDITIONS⁽¹⁾

Voltage with respect to V_{SS} (unless otherwise noted)

		MIN	NOM	MAX	UNIT
V_I	Input voltage range ARTN, COM, PPD, RTN, V_{DD} , V_{DD1}	0		57	V
	Input voltage range APb, V_C to [ARTN, COM]	0		18	V
	Input voltage range APD, CTL to [ARTN, COM]	0		V_B	V
	Input voltage range CS to [ARTN, COM]	0		2	V
I	Continuous RTN current ($T_J \leq 125^\circ\text{C}$) ⁽²⁾			400	mA
I_S	Sourcing current, V_B	0	2.5	5	mA
C	V_B capacitance	0.08			μF
	R_{BLNK}	0		350	k Ω
	Synchronization pulse width input (when used)	25			ns
T_J	Operating junction temperature range	-40		125	$^\circ\text{C}$

(1) ARTN and COM tied to RTN.

(2) This is the minimum current-limit value. PDs should be designed for maximum currents below this value to provide for unit power-draw tolerance. IEEE 802.3at type 1 and IEEE 802.3-2008 compliant devices should not draw average current greater than 350 mA, or their class power.

DISSIPATION RATINGS

PACKAGE	Ψ_{JT} $^\circ\text{C/W}^{(1)}$	θ_{JA} $^\circ\text{C/W}^{(2)}$	θ_{JA} $^\circ\text{C/W}^{(3)}$
PWP (TSSOP-20)	0.7 / 0.45	135	74

(1) Thermal resistance junction to case top, low-k / high-k board, natural convection, $T_J = T_{TOP} + (\Psi_{JT} \times P_J)$. Use Ψ_{JT} to validate T_J from measurements.

(2) JEDEC method with low-k board (1 signal layer), natural convection.

(3) JEDEC method with high-k board (2 signal – 2 plane layers).

ELECTRICAL CHARACTERISTICS

Unless otherwise noted: CS=COM=APD=CTL=RTN=ARTN, GATE and GAT2 float, $R_{FRS} = 68.1\text{ k}\Omega$, $R_{BLNK} = 249\text{ k}\Omega$, $DT = V_B$, PPD = V_{SS} , APb open, $C_{VB} = C_{VC} = 0.1\text{ }\mu\text{F}$, $R_{DEN} = 24.9\text{ k}\Omega$, R_{CLS} open, $0\text{ V} \leq (V_{DD}, V_{DD1}) \leq 57\text{ V}$, $0\text{ V} \leq V_C \leq 18\text{ V}$, $-40^\circ\text{C} \leq T_J \leq 125^\circ\text{C}$. Typical specifications are at 25°C .

CONTROLLER SECTION ONLY

 $[V_{SS} = \text{RTN and } V_{DD} = V_{DD1}]$ or $[V_{SS} = \text{RTN} = V_{DD}]$, all voltages referred to [ARTN, COM] (unless otherwise noted).

PARAMETER		TEST CONDITIONS	MIN	TYP	MAX	UNIT
V_C						
V_{CUV}	UVLO	V_C rising	8.7	9	9.3	V
V_{CUVH}		Hysteresis ⁽¹⁾	3.3	3.5	3.7	
	Operating current	$V_C = 12\text{ V}$, CTL = V_B , $R_{DT} = 68.1\text{ k}\Omega$	0.7	0.92	1.2	mA
t_{ST}	Bootstrap startup time, $C_{VC} = 22\text{ }\mu\text{F}$	$V_{DD1} = 10.2\text{ V}$, $V_C(0) = 0\text{ V}$	50	85	175	ms
		$V_{DD1} = 35\text{ V}$, $V_C(0) = 0\text{ V}$	27	45	92	
	Startup current source - I_{VC}	$V_{DD1} = 10.2\text{ V}$, $V_C = 8.6\text{ V}$	0.44	1.06	1.80	mA
		$V_{DD1} = 48\text{ V}$, $V_C = 0\text{ V}$	2.7	4.8	6.8	
V_B						
	Voltage	$6.5\text{ V} \leq V_C \leq 18\text{ V}$, $0 \leq I_{VB} \leq 5\text{ mA}$	4.8	5.10	5.25	V

(1) The hysteresis tolerance tracks the rising threshold for a given device.

TPS23757

SLVS948D – JULY 2009 – REVISED NOVEMBER 2013

www.ti.com

PARAMETER		TEST CONDITIONS	MIN	TYP	MAX	UNIT
FRS						
Switching frequency		CTL = V _B , measure GATE, R _{FRS} = 68.1 kΩ	227	253	278	kHz
D _{MAX}	Duty cycle	CTL = V _B , measure GATE	76	78	80	%
V _{SYNC}	Synchronization	Input threshold	2	2.2	2.4	V
CTL						
V _{ZDC}	0% duty cycle threshold	V _{CTL} ↓ until GATE stops	1.3	1.5	1.7	V
Softstart period		Interval from switching start to V _{CSMAX}	1.9	3.9	6.2	ms
Input resistance			70	100	145	kΩ
BLNK						
Blanking delay (In addition to t ₁)		BLNK = RTN	35	55	78	ns
		R _{BLNK} = 49.9 kΩ	38	55	70	
DT						
Dead time See Figure 2 for t _{DTx} definition		CTL = V _B , C _{GATE} = 1 nF, C _{GAT2} = 1 nF, measure GATE, GAT2				ns
		R _{DT} = 24.9 kΩ, GAT2 ↑ to GATE ↑	40	50	62.5	
		R _{DT} = 24.9 kΩ, GATE ↓ to GAT2 ↓	40	50	62.5	
		R _{DT} = 75 kΩ, GAT2 ↑ to GATE ↑	120	150	188	
		R _{DT} = 75 kΩ, GATE ↓ to GAT2 ↓	120	150	188	
CS						
V _{CSMAX}	Maximum threshold voltage	V _{CTL} = V _B , V _{CS} rising until GATE duty cycle drops	0.5	0.55	0.6	V
t ₁	Turnoff delay	V _{CS} = 0.65 V	24	40	70	ns
V _{SLOPE}	Internal slope compensation voltage	Peak voltage at maximum duty cycle, referenced to CS	120	155	185	mV
I _{SL_EX}	Peak slope compensation current	V _{CTL} = V _B , I _{CS} at maximum duty cycle	30	42	54	μA
Bias current (sourcing)		DC component of I _{CS}	1	2.5	4.3	μA
GATE						
Source current		V _{CTL} = V _B , V _C = 12 V, GATE high, pulsed measurement	0.37	0.6	0.95	A
Sink current		V _{CTL} = V _B , V _C = 12 V, GATE low, pulsed measurement	0.7	1.0	1.4	A
GAT2						
Source current		V _{CTL} = V _B , V _C = 12 V, GAT2 high, R _{DT} = 24.9 kΩ, pulsed measurement	0.37	0.6	0.95	A
Sink current		V _{CTL} = V _B , V _C = 12 V, GAT2 low, R _{DT} = 24.9 kΩ, pulsed measurement	0.7	1.0	1.4	A
APD / PPD						
V _{APDEN}	APD threshold voltage	V _{APD} rising	1.43	1.5	1.57	V
V _{APDH}		Hysteresis ⁽²⁾	0.29	0.31	0.33	
V _{PPDEN}	PPD threshold voltage	V _{PPD} - V _{VSS} rising, UVLO disable	1.45	1.55	1.65	V
V _{PPDH}		Hysteresis ⁽²⁾	0.29	0.31	0.33	
V _{PPD2}		V _{PPD} - V _{VSS} rising, Class enable	7.4	8.3	9.2	V
V _{PPD2H}		Hysteresis ⁽²⁾	0.5	0.6	0.7	
APD leakage current (source or sink)		V _C = 12 V, V _{APD} = V _B			1	μA
I _{PPD}	PPD sink current	V _{PPD} - V _{VSS} = 1.5 V	2.5	5	7.5	μA
THERMAL SHUTDOWN						
Turnoff temperature		T _J rising	135	145	155	°C
Hysteresis ⁽³⁾				20		°C

(2) The hysteresis tolerance tracks the rising threshold for a given device.

(3) These parameters are provided for reference only, and do not constitute part of TI's published specifications for purposes of TI's product warranty.

ELECTRICAL CHARACTERISTICS – PoE AND CONTROL
 $[V_{DD} = V_{DD1}]$ or $[V_{DD1} = RTN]$, $V_C = RTN$, $COM = RTN = ARTN$, all voltages referred to V_{SS} unless otherwise noted

PARAMETER		TEST CONDITIONS	MIN	TYP	MAX	UNIT
DETECTION (DEN)		$(V_{DD} = V_{DD1} = RTN = V_{SUPPLY} \text{ positive})$				
Detection current		Measure I_{SUPPLY}				μA
		$V_{DD} = 1.6 \text{ V}$	62	64.3	66.5	
		$V_{DD} = 10 \text{ V}$	399	406	414	
Detection bias current		$V_{DD} = 10 \text{ V}$, float DEN, measure I_{SUPPLY}		5.6	10	μA
V_{PD_DIS}	Hotswap disable threshold		3	4	5	V
DEN leakage current		$V_{DEN} = V_{DD} = 57 \text{ V}$, float V_{DD1} and RTN, measure I_{DEN}		0.1	5	μA
CLASSIFICATION (CLS)		$(V_{DD} = V_{DD1} = RTN = V_{SUPPLY} \text{ positive})$				
I_{CLS}	Classification current, applies to both cycles	$13 \text{ V} \leq V_{DD} \leq 21 \text{ V}$, Measure I_{SUPPLY}				mA
		$R_{CLS} = 1270 \Omega$	1.8	2.1	2.4	
		$R_{CLS} = 243 \Omega$	9.9	10.4	10.9	
		$R_{CLS} = 137 \Omega$	17.6	18.5	19.4	
		$R_{CLS} = 90.9 \Omega$	26.5	27.7	29.3	
		$R_{CLS} = 63.4 \Omega$	38.0	39.7	42	
V_{CL_ON}	Classification regulator lower threshold	Regulator turns on, V_{DD} rising	11.2	11.9	12.6	V
V_{CL_H}		Hysteresis ⁽¹⁾	1.55	1.65	1.75	
V_{CU_OFF}	Classification regulator upper threshold	Regulator turns off, V_{DD} rising	21	22	23	V
V_{CU_H}		Hysteresis ⁽¹⁾	0.5	0.75	1.0	
Leakage current		$V_{DD} = 57 \text{ V}$, $V_{CLS} = 0 \text{ V}$, DEN = V_{SS} , measure I_{CLS}			1	μA
PASS DEVICE (RTN)		$(V_{DD1} = RTN)$				
On resistance			0.25	0.43	0.8	Ω
Current limit		$V_{RTN} = 1.5 \text{ V}$, $V_{DD} = 48 \text{ V}$, pulsed measurement	400	465	535	mA
Inrush limit		$V_{RTN} = 2 \text{ V}$, $V_{DD}: 0 \text{ V} \rightarrow 48 \text{ V}$, pulsed measurement	100	140	180	mA
Foldback voltage threshold		V_{DD} rising	11	12.3	13.6	V
UVLO						
$UVLO_R$	UVLO threshold	V_{DD} rising	33.9	35	36.1	V
$UVLO_H$		Hysteresis ⁽¹⁾	4.4	4.55	4.76	
APb		$V_C = 12 \text{ V}$, float V_{DD1} , $V_{DD} = 48 \text{ V}$, $ARTN = V_{SS}$				
ON characteristic		$V_{APD} = 2 \text{ V}$, $CTL = ARTN$, $(V_{APb} - V_{ARTN}) = 0.6 \text{ V}$	2			mA
Leakage current		$V_{APb} = 18 \text{ V}$, $(V_{APD} - V_{ARTN}) = 0 \text{ V}$, $(V_{PPD} - V_{VSS}) = 0 \text{ V}$			10	μA
t_{APb}	Delay	From start of switching to APb active	5	9	15	ms
THERMAL SHUTDOWN						
Turnoff temperature		T_J rising	135	145	155	$^{\circ}C$
Hysteresis ⁽²⁾				20		$^{\circ}C$

(1) The hysteresis tolerance tracks the rising threshold for a given device.

(2) These parameters are provided for reference only, and do not constitute part of TI's published specifications for purposes of TI's product warranty.

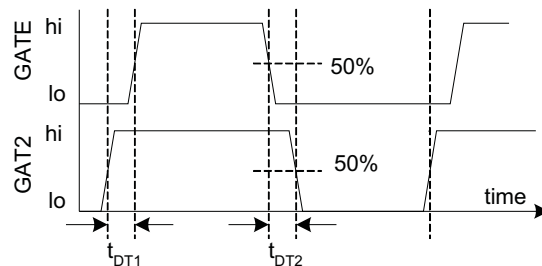
Figure 2. GATE and GAT2 Timing and Phasing

DEVICE INFORMATION
FUNCTIONAL BLOCK DIAGRAM

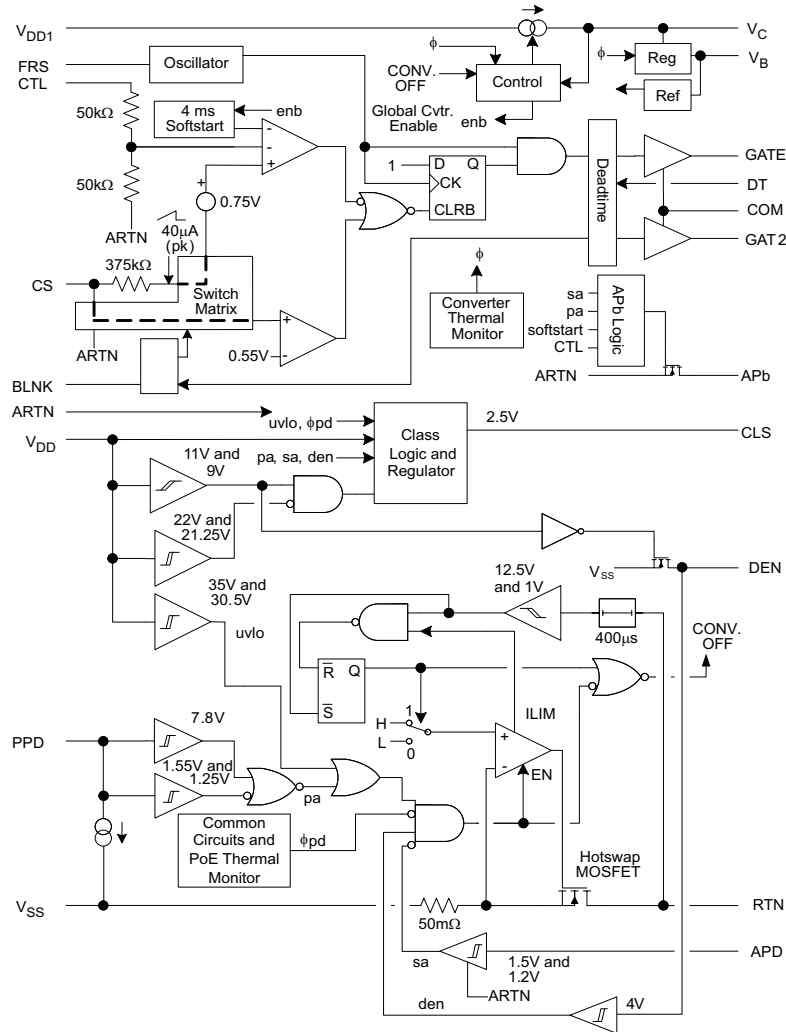

PWP PACKAGE
(TOP VIEW)

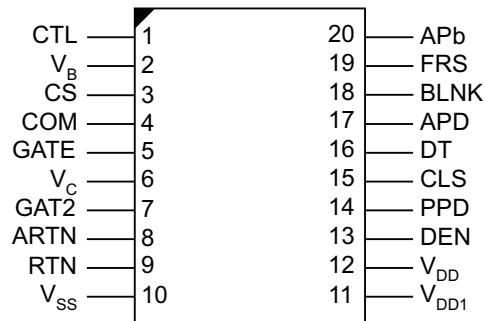

PIN FUNCTIONS

NAME	NO.	TYPE	DESCRIPTION
CTL	1	I	The control loop input to the PWM (pulse width modulator), typically driven by output regulation feedback (e.g. optocoupler). Use V_B as a pullup for CTL.
V_B	2	O	5.1 V bias rail for dc/dc control circuits and the feedback optocoupler. Typically bypass with a 0.1 μ F to ARTN.
CS	3	I/O	DC/DC converter switching MOSFET current sense input. See R_{CS} in Figure 1 .
COM	4		Gate driver return, connect to ARTN, and RTN for most applications.
GATE	5	O	Gate drive output for the main dc/dc converter switching MOSFET.
V_C	6	I/O	DC/DC converter bias voltage. Connect a 0.47 μ F (minimum) ceramic capacitor to ARTN at the pin, and a larger capacitor to power startup.
GAT2	7	O	Gate drive output for a second dc/dc converter switching MOSFET (see Figure 1).
ARTN	8		ARTN is the dc/dc converter analog return. Tie to COM, and RTN for most applications.
RTN	9		RTN is the output of the PoE hotswap MOSFET.
V_{SS}	10		Connect to the negative power rail derived from the PoE source.
V_{DD1}	11	I	Source of dc/dc converter startup current. Connect to V_{DD} for many applications.
V_{DD}	12	I	Connect to the positive PoE input power rail. V_{DD} powers the PoE interface circuits. Bypass with a 0.1 μ F capacitor and protect with a TVS.
DEN	13	I/O	Connect a 24.9 k Ω resistor from DEN to V_{DD} to provide the PoE detection signature. Pulling this pin to V_{SS} during powered operation causes the internal hotswap MOSFET to turn off.
PPD	14	I	Raising $V_{PPD} - V_{VSS}$ above 1.55 V enables the hotswap MOSFET and activates APb. Connecting PPD to V_{DD} enables classification when APD is active. Tie PPD to V_{SS} or float when not used.
CLS	15	I	Connect a resistor from CLS to V_{SS} to program classification current per Table 1 .
DT	16	I	Connect a resistor from DT to ARTN to set the GATE to GAT2 dead time. Tie DT to V_B to disable GAT2 operation.
APD	17	I	Raising $V_{APD} - V_{ARTN}$ above 1.5 V disables the internal hotswap MOSFET, turns class off, and forces APb active. This forces power to come from an external $V_{DD1} - V_{RTN}$ adapter. Tie APD to ARTN when not used.
BLNK	18	I	Connect to ARTN to utilize the internally set current-sense blanking period, or connect a resistor from BLNK to ARTN to program a more accurate period.
FRS	19	I	Connect a resistor from FRS to ARTN to program the converter switching frequency. FRS may be used to synchronize the converter to an external timing source.
APb	20	O	Active low output that indicates PPD (first level) or APD are active.

PIN DESCRIPTION

See [Figure 1](#) for component reference designators (R_{CS} for example), and the Electrical Characteristics table for values denoted by reference (V_{CSMAX} for example). Electrical Characteristic values take precedence over any numerical values used in the following sections.

APD

APD (adapter priority detect) forces power to come from an external adapter connected from V_{DD1} to RTN by opening the hotswap switch, disabling the CLS output (see PPD pin description), and enabling the APb output. A resistor divider is recommended on APD when it is connected to an external adapter. The divider provides ESD protection, leakage discharge for the adapter ORing diode, and input voltage qualification. Voltage qualification assures the adapter output voltage is high enough that it can support the PD before the PoE current is cut off.

Select the APD divider resistors per [Equation 1](#) where V_{ADPTR_ON} is the desired adapter voltage that enables the APD function as adapter voltage rises.

$$R_{APD1} = R_{APD2} \times (V_{ADPTR_ON} - V_{APDEN}) / V_{APDEN}$$

$$V_{ADPTR_OFF} = \frac{R_{APD1} + R_{APD2}}{R_{APD2}} \times (V_{APDEN} - V_{APDH}) \quad (1)$$

Place the APD pull-down resistor adjacent to the APD pin.

APD should be tied to ARTN when not used.

BLNK

Blanking provides an interval between GATE going high and the current-control comparators on CS actively monitoring the input. This delay allows the normal turn-on current transient (spike) to subside before the comparators are active, preventing undesired short duty cycles and premature current limiting.

Connect BLNK to ARTN to obtain the internally set blanking period. Connect a resistor from BLNK to ARTN for a more accurate, programmable blanking period. The relationship between the desired blanking period and the programming resistor is defined by [Equation 2](#).

$$R_{\text{BLNK}} (\text{k}\Omega) = t_{\text{BLNK}} (\text{ns}) \quad (2)$$

Place the resistor adjacent to the BLNK pin when it is used.

CLS

A resistor from CLS (class) to V_{SS} programs the classification current per the IEEE standard. The PD power ranges and corresponding resistor values are listed in [Table 1](#). The power assigned should correspond to the maximum average power drawn by the PD during operation.

Table 1. Class Resistor Selection

CLASS	POWER AT PD		RESISTOR (Ω)	NOTES
	MINIMUM (W)	MAXIMUM (W)		
0	0.44	13	1270	Minimum may be reduced by pulsed loading. Serves as a catch-all default class.
1	0.44	3.84	243	
2	3.84	6.49	137	
3	6.49	13	90.9	
4	13	25.5	63.4	Not allowed prior to IEEE 802.3at. Maximum type 2 hardware class current levels not supported by TPS23757.

CS

The CS (current sense) input for the dc/dc converter should be connected to the high side of the switching MOSFET's current sense resistor (R_{CS}). The current-limit threshold, V_{CSMAX} , defines the voltage on CS above which the GATE ON time will be terminated regardless of the voltage on CTL.

The TPS23757 provides internal slope compensation (155 mV, V_{SLOPE}), an output current for additional slope compensation, a peak current limiter, and an off-time pull-down to this pin.

Routing between the current-sense resistor and the CS pin should be short to minimize cross-talk from noisy traces such as the gate drive signal.

CTL

CTL (control) is the voltage-control loop input to the PWM (pulse width modulator). Pulling V_{CTL} below V_{ZDC} (zero duty cycle voltage) causes GATE to stop switching. Increasing V_{CTL} above V_{ZDC} raises the switching MOSFET programmed peak current. The maximum (peak) current is requested at approximately $V_{\text{ZDC}} + (2 \times V_{\text{CSMAX}})$. The ac gain from CTL to the PWM comparator is 0.5. The internal divider from CTL to ARTN is approximately 100 k Ω .

Use V_{B} as a pull up source for CTL.

DEN

DEN (detection and enable) is a multifunction pin for PoE detection and inhibiting operation from PoE power. Connect a 24.9 k Ω resistor from DEN to V_{DD} to provide the PoE detection signature. DEN goes to a high-impedance state when $V_{\text{VDD}} - V_{\text{VSS}}$ is outside of the detection range. Pulling DEN to V_{SS} during powered operation causes the internal hotswap MOSFET and class regulator to turn OFF, while the reduced detection resistance prevents the PD from properly re-detecting. See *Using DEN to Disable PoE*.

DT

Dead-time programming sets the delay between GATE and GAT2 to prevent overlap of MOSFET ON times as shown in [Figure 2](#). GAT2 turns the second MOSFET OFF when it transitions high. Both MOSFETs should be OFF between GAT2 going high to GATE going high, and GATE going low to GAT2 going low. The maximum GATE ON time is reduced by the programmed dead-time period. The dead time period is specified with 1 nF of capacitance on GATE and GAT2. Different loading on these pins will change the effective dead time.

A resistor connected from DT to ARTN sets the delay between GATE and GAT2 per [Equation 3](#).

$$R_{DT} \text{ (k}\Omega\text{)} = \frac{t_{DT} \text{ (ns)}}{2} \quad (3)$$

Connect DT to V_B to set the dead time to 0 and turn GAT2 OFF.

FRS

Connect a resistor from FRS (frequency and synchronization) to ARTN to program the converter switching frequency. Select the resistor per the following relationship.

$$R_{FRS} \text{ (k}\Omega\text{)} = \frac{17250}{f_{SW} \text{ (kHz)}} \quad (4)$$

The converter may be synchronized to a frequency above its maximum free-running frequency by applying short ac-coupled pulses into the FRS pin per [Figure 25](#).

The FRS pin is high impedance. Keep the connections short and apart from potential noise sources. Special care should be taken to avoid crosstalk when synchronizing circuits are used.

GATE

Gate drive output for the dc/dc converter's main switching MOSFET. GATE's phase turns the main switch ON when it transitions high, and OFF when it transitions low. GATE is held low when the converter is disabled.

GAT2

GAT2 is the second gate drive output for the dc/dc converter. GAT2's phase turns the second switch OFF when it transitions high, and ON when it transitions low. This drives flyback synchronous rectifiers per [Figure 1](#). See the DT Pin Description for GATE to GAT2 timing. Connecting DT to V_B disables GAT2 in a high-impedance condition. GAT2 is low when the converter is disabled.

PPD

PPD is a multifunction pin that has two voltage thresholds, PPD1 and PPD2.

PPD1 permits power to come from an external low voltage adapter, e.g., 24 V, connected from V_{DD} to V_{SS} by over-riding the normal hotswap UVLO. Voltage on PPD above 1.55 V (V_{PPDEN}) enables the hotswap MOSFET, inhibits class current, and enables APb. A resistor divider per [Figure 30](#) provides ESD protection, leakage discharge for the adapter ORing diode, reverse adapter protection, and input voltage qualification. Voltage qualification assures the adapter output voltage is high enough that it can support the PD before it begins to draw current.

$$R_{PPD1} = \left(\frac{V_{ADPTR_ON} - V_{PPDEN}}{\frac{V_{PPDEN}}{R_{PPD2}} + I_{PPD}} \right)$$

$$V_{ADPTR_OFF} = (V_{PPDEN} - V_{PPDH}) + \left[R_{PPD1} \times \left(\frac{(V_{PPDEN} - V_{PPDH})}{R_{PPD2}} + I_{PPD} \right) \right] \quad (5)$$

PPD2 enables normal class regulator operation when V_{PPD} is above 8.3 V to permit normal classification when APD is used in conjunction with diode D_{VDD} (see [Figure 29](#)). Tie PPD to V_{DD} when PPD2 operation is desired.

TPS23757

SLVS948D – JULY 2009 – REVISED NOVEMBER 2013

www.ti.com

The PPD pin has a 5 μ A internal pull-down current.

Locate the PPD pull-down resistor adjacent to the pin when used.

PPD may be tied to V_{SS} or left open when not used.

RTN, ARTN, COM

RTN is internally connected to the drain of the PoE hotswap MOSFET, while ARTN is the quiet analog return for the dc/dc controller. COM serves as the return path for the gate drivers and should be tied to ARTN on the circuit board. The ARTN / COM / RTN net should be treated as a local reference plane (ground plane) for the dc/dc control and converter primary. RTN and (ARTN/COM) may be separated by several volts for special applications.

APb

APb is an active low output that indicates [($V_{APD} > 1.5$ V) OR (1.55 V $\leq V_{PPD} \leq 8.3$ V)]. APb is valid after both a delay of t_{APb} from the start of converter switching, and [$V_{CTL} \leq (V_B - 1$ V)]. Once APb is valid, V_{CTL} will not effect it. APb will become invalid if the converter goes back into softstart, overtemperature, or is held off by the PD during C_{IN} recharge (inrush). APb is referenced to ARTN and is intended to drive the diode side of an optocoupler. APb should be left open or tied to ARTN if not used.

V_B

V_B is an internal 5.1 V regulated dc/dc controller supply rail that is typically bypassed by a 0.1 μ F capacitor to ARTN. V_B should be used to bias the feedback optocoupler.

V_C

V_C is the bias supply for the dc/dc controller. The MOSFET gate drivers run directly from V_C . V_B is regulated down from V_C , and is the bias voltage for the rest of the converter control. A startup current source from V_{DD1} to V_C is controlled by a comparator with hysteresis to implement the converter bootstrap startup. V_C must be connected to a bias source, such as a converter auxiliary output, during normal operation.

A minimum 0.47 μ F capacitor, located adjacent to the V_C pin, should be connected from V_C to COM to bypass the gate driver. A larger total capacitance is required for startup to provide control power between the time the converter starts switching and the availability of the converter auxiliary output voltage.

V_{DD}

V_{DD} is the positive input power rail that is derived from the PoE source (PSE). V_{DD} should be bypassed to V_{SS} with a 0.1 μ F capacitor as required by the IEEE standard. A transient suppressor diode (TVS), such as SMAJ58A should be connected from V_{DD} to V_{SS} to protect against overvoltage transients.

V_{DD1}

V_{DD1} is the dc/dc converter startup supply. Connect to V_{DD} for many applications. V_{DD1} may be isolated by a diode from V_{DD} to support PoE priority operation.

V_{SS}

V_{SS} is the PoE input-power return side. It is the reference for the PoE interface circuits, and has a current-limited hotswap switch that connects it to RTN. V_{SS} is clamped to a diode drop above RTN by the hotswap switch.

A local V_{SS} reference plane should be used to connect the input bypass capacitor, TVS, and R_{CLS} .

TYPICAL CHARACTERISTICS

DETECTION BIAS CURRENT
VS
VOLTAGE

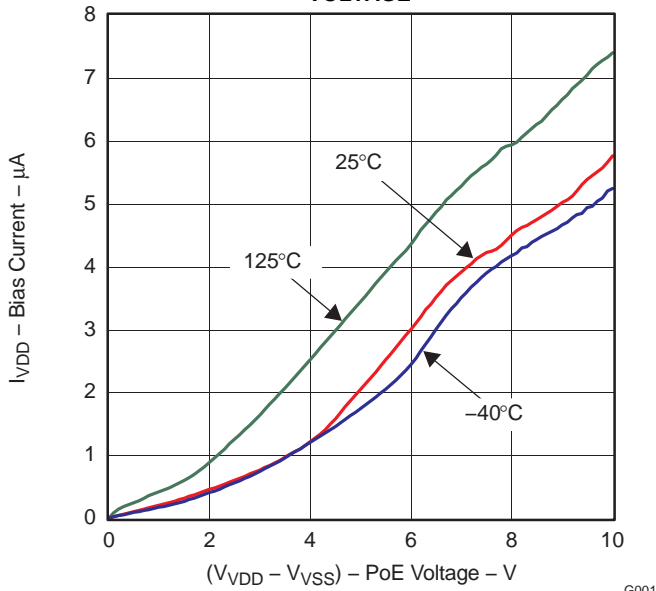

Figure 3.

PoE CURRENT LIMIT
VS
TEMPERATURE

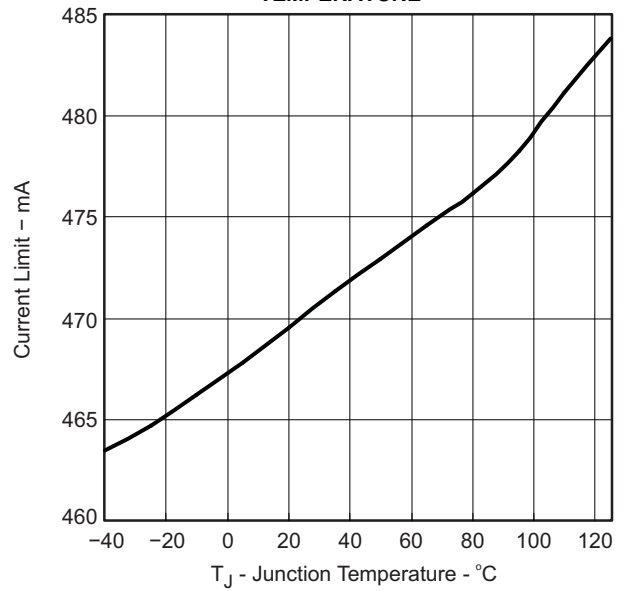

Figure 4.

CONVERTER START TIME
VS
TEMPERATURE

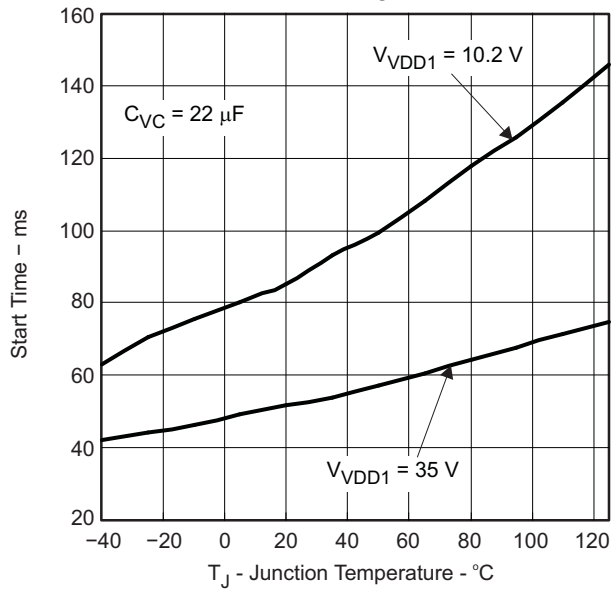

Figure 5.

CONVERTER STARTUP CURRENT
VS
V_{VDD1}

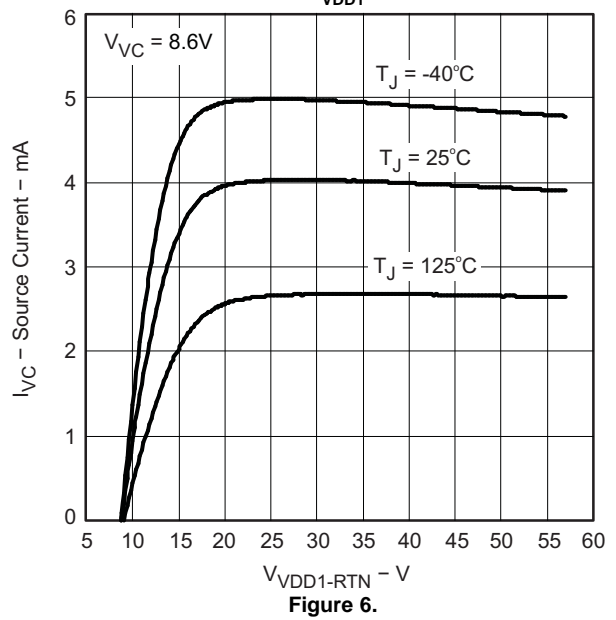

Figure 6.

TYPICAL CHARACTERISTICS (continued)

**CONTROLLER BIAS CURRENT
VS
TEMPERATURE**

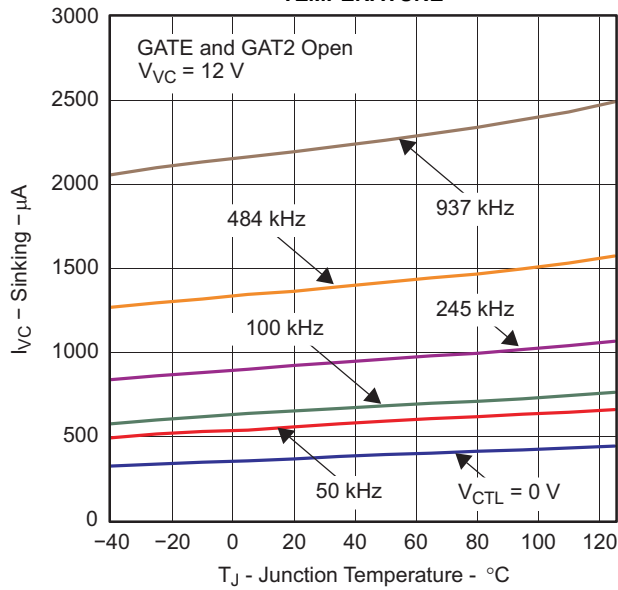

Figure 7.

G005

**CONTROLLER BIAS CURRENT
VS
VOLTAGE**

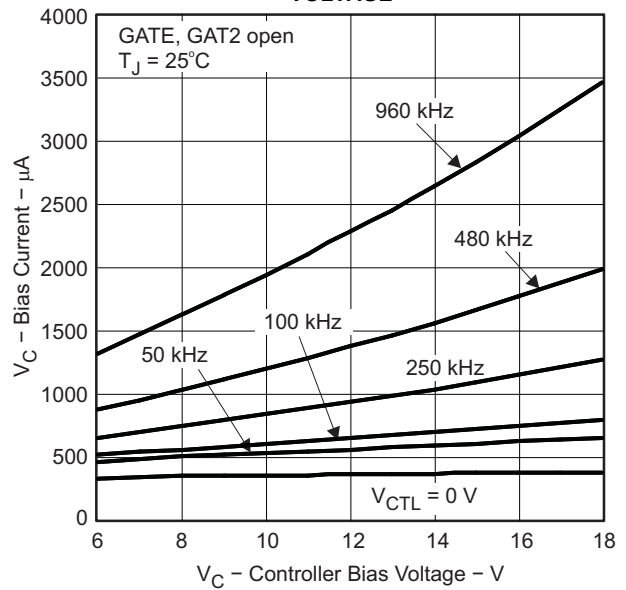

Figure 8.

**SWITCHING FREQUENCY
VS
TEMPERATURE**

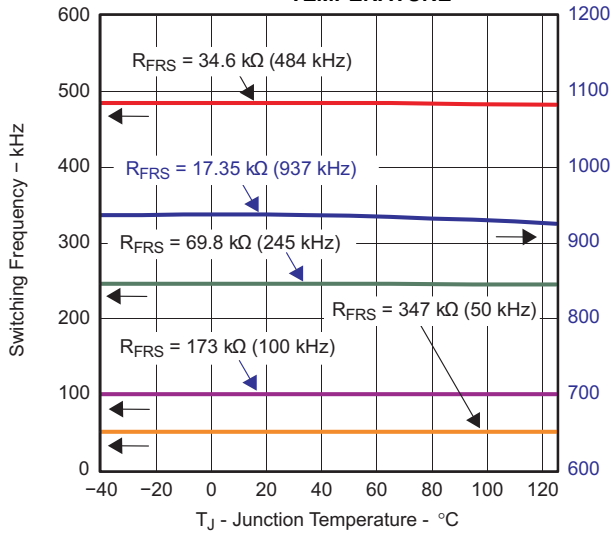

Figure 9.

G007

**SWITCHING FREQUENCY
VS
PROGRAM CONDUCTANCE**

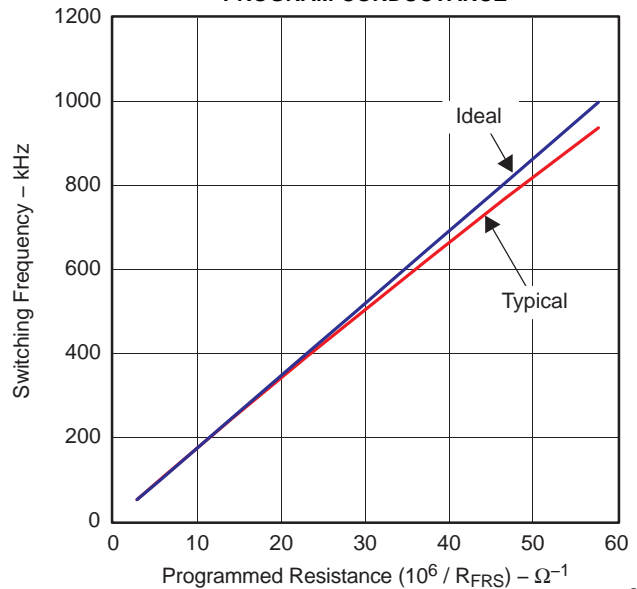

Figure 10.

G008

TYPICAL CHARACTERISTICS (continued)
MAXIMUM DUTY CYCLE VS TEMPERATURE
CURRENT SLOPE COMPENSATION VOLTAGE VS TEMPERATURE

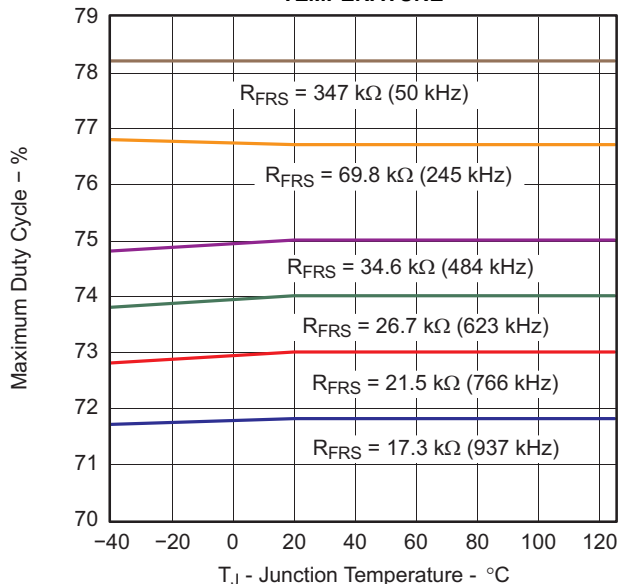

Figure 11.

G009

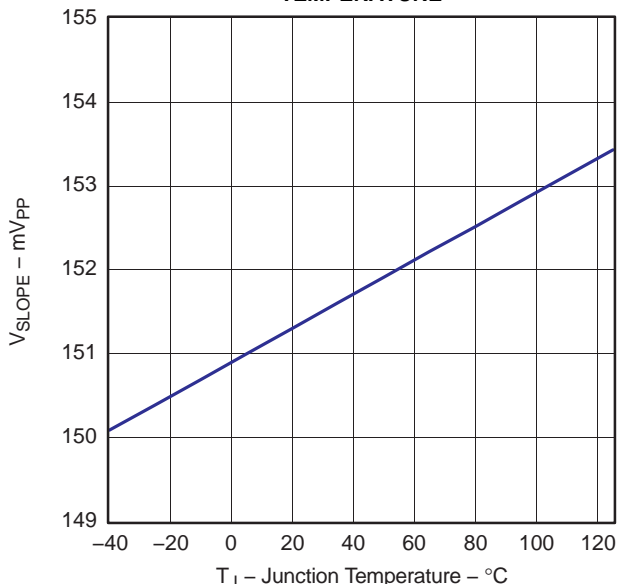

Figure 12.

G010

CURRENT SLOPE COMPENSATION CURRENT VS TEMPERATURE

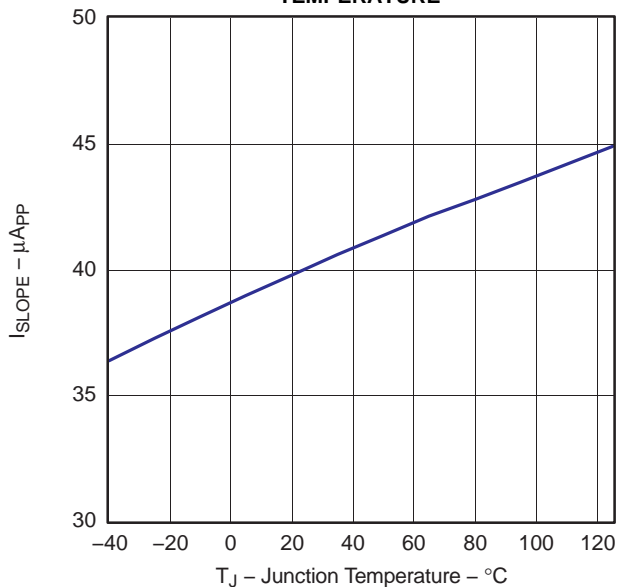

Figure 13.

G011

BLANKING PERIOD VS TEMPERATURE

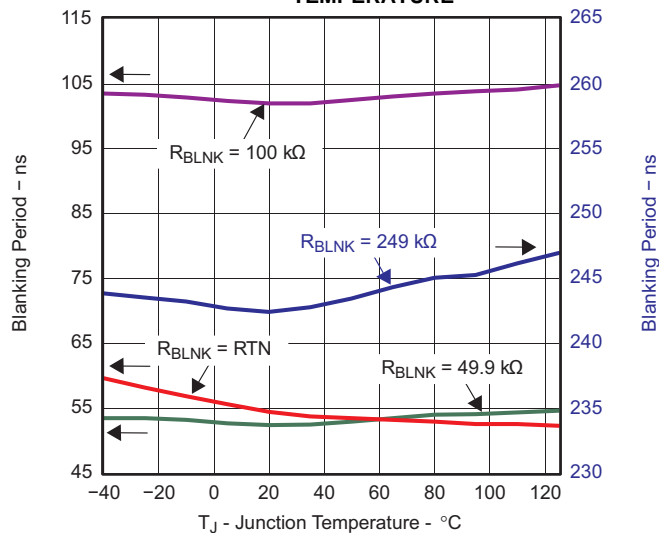

Figure 14.

G012

TYPICAL CHARACTERISTICS (continued)

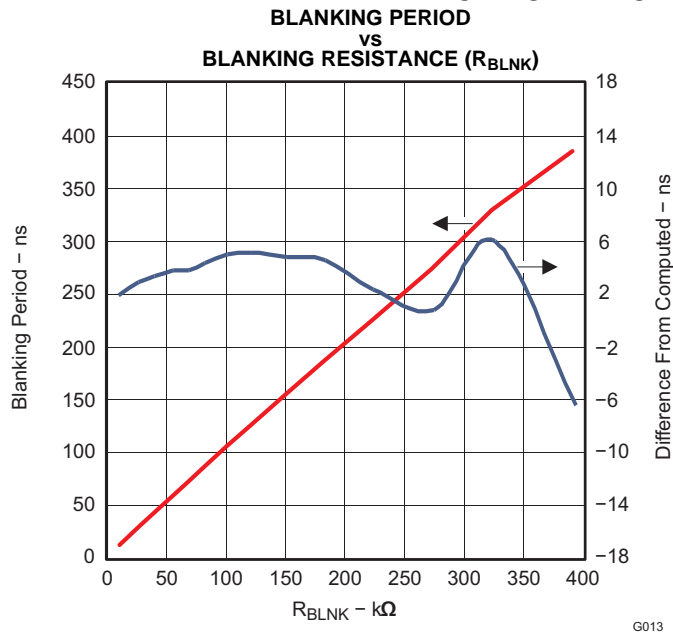

Figure 15.

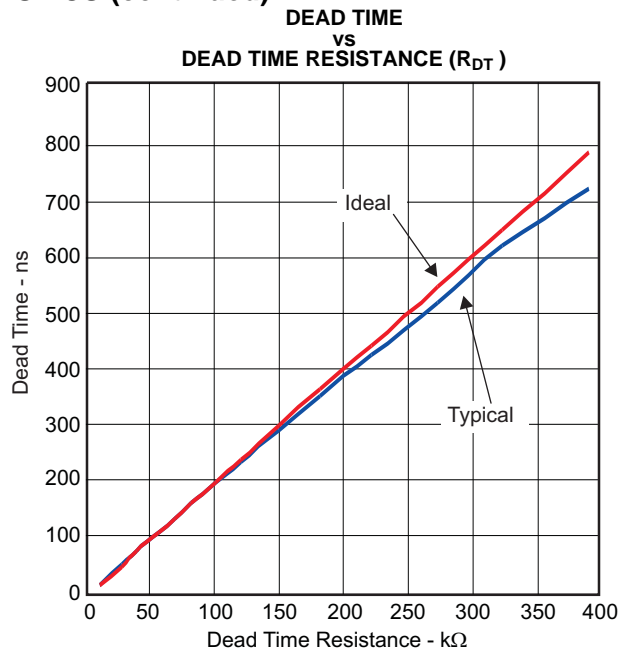

Figure 16.

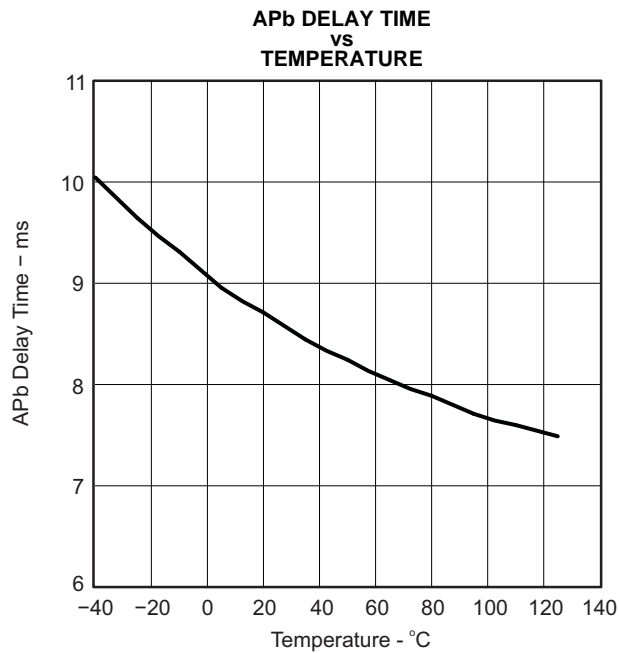

Figure 17.

DETAILED DESCRIPTION

PoE OVERVIEW

The following text is intended as an aid in understanding the operation of the TPS23757 but not as a substitute for the IEEE 802.3at standard. The IEEE 802.3at standard is an update to IEEE 802.3-2008 clause 33 (PoE), adding high-power options and enhanced classification. Generally speaking, a device compliant to IEEE 802.3-2008 will be referred to as a type 1 device (PD or PSE), and devices with high power and enhanced classification will be referred to as type 2 devices (PD or PSE). Standards change and should always be referenced when making design decisions. The TPS23757 supports type 1 PDs as a result of the limited-current capability and lack of type 2 hardware class detection. Type 1 devices are encompassed within the new standard, providing the same features and functions as devices in service since 2003.

The IEEE 802.3at standard defines a method of safely powering a PD over a cable by power sourcing equipment (PSE), and then removing power if a PD is disconnected. The process proceeds through an idle state and three states of detection, classification, and operation. The PSE leaves the cable unpowered (idle state) while it periodically looks to see if something has been plugged in; this is referred to as detection. The low power levels used during detection are unlikely to damage devices not designed for PoE. If a valid PD signature is present, the PSE may inquire how much power the PD requires; this is referred to as classification. The PSE may then power the PD if it has adequate capacity.

Type 2 PSEs are required to do type 1 hardware classification plus a (new) data-layer classification, or an enhanced type 2 hardware classification. Type 1 PSEs are not required to do hardware or data link layer (DLL) classification. A type 2 PD must do type 2 hardware classification as well as DLL classification. A type 1 PD may have passive classification (class 0, < 5 mA) or active type 1 hardware class (1 through 3) per IEEE 802.3-2008. DLL communication occurs after power-on and the ethernet data link has been established by the applications circuits in the PD (not the power interface). It may be used by type 1 PDs and must be implemented by type 2 PDs.

Once started, the PD must present the maintain power signature (MPS) to assure the PSE that it is still present. The PSE monitors its output for a valid MPS, and turns the port off if it loses the MPS. Loss of the MPS returns the PSE to the idle state. Figure 18 shows the operational states as a function of PD input voltage. The upper half is for IEEE 802.3-2008, and the lower half shows specific differences for IEEE 802.3at. The dashed lines in the lower half indicate these are the same (e.g., detect and class) for both.

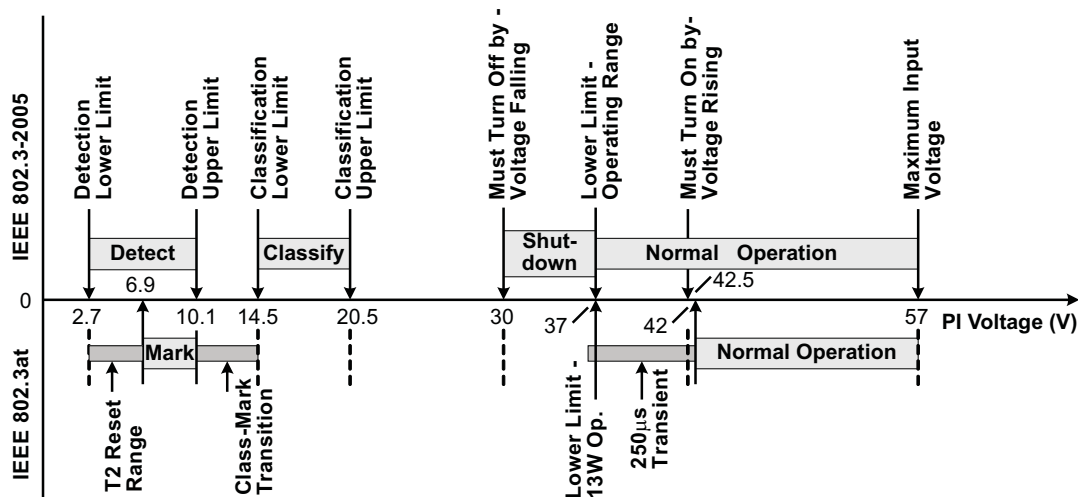

Figure 18. Operational States for PD

The PD input, typically an RJ-45 eight-lead connector, is referred to as the power interface (PI). PD input requirements differ from PSE output requirements to account for voltage drops in the channel and operating margin. The standard allots the maximum loss to the cable regardless of the actual installation to simplify implementation. IEEE 802.3-2008 (and IEEE 802.3at type 1) was designed to run over infrastructure including ISO/IEC 11801 class C (CAT3 per TIA/EIA-568) that may have had AWG 26 conductors and 20 Ω power loops. IEEE 802.3at (type 2) cabling power loss allotments and voltage drops have been adjusted for 12.5 Ω power loops per ISO/IEC11801 class D (CAT5 or higher per TIA/EIA-568, typically AWG #24 conductors). Table 2 shows key operational limits broken out for the two revisions of the standard.

Table 2. Comparison of Operational Limits

STANDARD	POWER LOOP RESISTANCE (max)	PSE OUTPUT POWER (min)	PSE STATIC OUTPUT VOLTAGE (min)	PD INPUT POWER (max)	STATIC PD INPUT VOLTAGE	
					POWER ≤ 13 W	POWER > 13 W
'2008 & 802.3at type 1	20 Ω	15.4 W	44 V	13 W	37 V–57 V	N/A
802.3at type 2	12.5 Ω	30 W	50 V	25.5 W	37 V–57 V	42.5 V–57 V

The PSE can apply voltage either between the RX and TX pairs (pins 1 - 2 and 3 - 6 for 10baseT or 100baseT), or between the two spare pairs (4 - 5 and 7 - 8) in either polarity. Power application to the same pin combinations in 1000baseT systems is recognized in IEEE 802.3at. 1000baseT systems can handle data on all pairs, eliminating the spare pair terminology. The PSE may only apply voltage to one set of pairs at a time. The PD uses input diode bridges to accept power from any of the possible PSE configurations. The voltage drops associated with the input bridges create a difference between the standard limits at the PI and the TPS23757 specifications.

A compliant type 1 PD per IEEE 802.3at has the same requirements as a PD per IEEE 802.3-2008.

Threshold Voltages

The TPS23757 has a number of internal comparators with hysteresis for stable switching between the various states. Figure 19 relates the parameters in the Electrical Characteristics section to the PoE states. The mode labeled *Idle* between classification and operation implies that the DEN, CLS, and RTN pins are all high impedance.

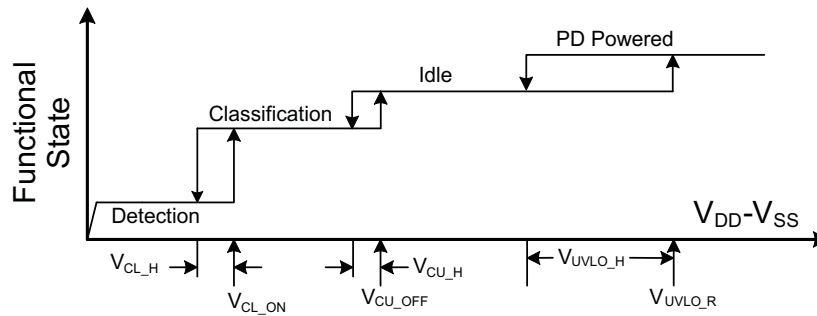

Note: Variable names refer to Electrical Characteristic Table parameters

Figure 19. Threshold Voltages

PoE Startup Sequence

The waveforms of Figure 20 demonstrate detection, classification, and startup from a PSE with type 1 hardware classification. The key waveforms shown are V_{VDD}-V_{VSS}, V_{RTN}-V_{VSS}, and I_{PI}. This figure shows two detection cycles (a *minimum* of two levels are required), a class cycle (a type 2 PSE need only do 1 hardware class cycle if it reads class 0 through 3), and startup. V_{RTN} to V_{SS} falls as the TPS23757 charges C_{IN} with inrush-limited current following application of full voltage. Subsequently, the converter starts up, drawing current as seen in the I_{PI} waveform.

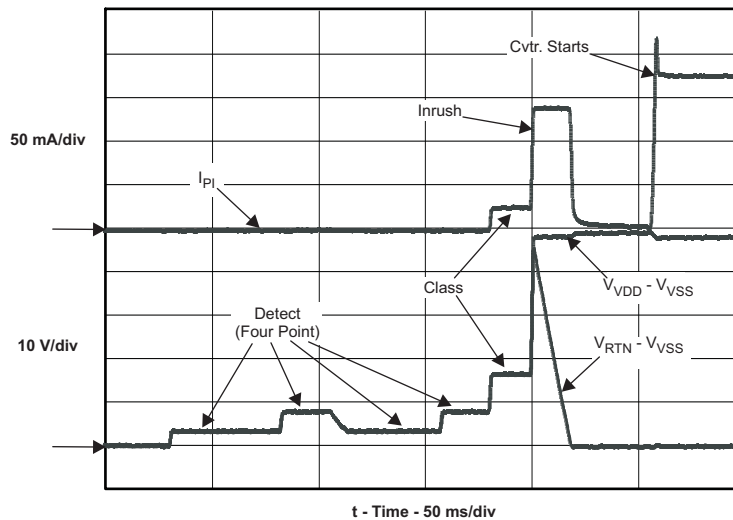

Figure 20. Startup

Detection

The TPS23757 drives DEN to V_{SS} whenever $V_{VDD} - V_{VSS}$ is in the detection state per Figure 19. When the input voltage rises above V_{CL-ON} , the DEN pin goes to an open-drain condition to conserve power. While in detection, RTN is high impedance, and almost all the internal circuits are disabled. An R_{DEN} of 24.9 k Ω (1%), presents the correct signature. It may be a small, low-power resistor since it only sees a stress of about 5 mW. A valid PD detection signature is an incremental resistance ($\Delta V / \Delta I$) between 23.7 k Ω and 26.3 k Ω at the PI.

The detection resistance seen by the PSE at the PI is the result of the input bridge resistance in series with the parallel combination of R_{DEN} and internal V_{DD} loading. The input diode bridge's incremental resistance may be hundreds of ohms at the very low currents drawn when 2.7 V is applied to the PI. The input bridge resistance is partially cancelled by the TPS23757's effective resistance during detection.

Detection is the same for type 1 and type 2 PDs.

Hardware Classification

Hardware classification allows a PSE to determine a PD's power requirements before powering, and helps with power management once power is applied. The PSE applies a voltage of between 14.5 V and 20.5 V at the PD PI and the PD responds with a current representing the class per the standard. A type 1 PD presents class 0 - 3 in hardware to indicate it is a low-power device (no change from IEEE 802.3-2008). Type 1 PD hardware class interoperates properly with type 2 PSEs. A type 1 PD must present the hardware class which covers its maximum power draw. IEEE 802.3at provides a new option for type 1 PDs to negotiate their power allocation to a lower level using DLL after startup. DLL communication is implemented by the ethernet communication system in the PD and is not implemented by the TPS23757.

The maximum power entries in Table 1 determine the class the PD must advertise. The PSE may disconnect a PD if it draws more than its stated class power, which may be the hardware class or an optional lower DLL-derived power level. The standard permits the PD to draw limited current peaks that increase the instantaneous power above the Table 1 limit, however the average power requirement always applies.

The TPS23757 disables classification above V_{CU-OFF} to avoid excessive power dissipation. CLS is turned off during PD thermal limit or when APD, PPD (level 1), or DEN are active. CLS is enabled when APD and PPD (level 2) are active. The CLS output is inherently current limited, but should not be shorted to V_{SS} for long periods of time.

Inrush and Startup

The TPS23757 provides a 140 mA inrush limit that is compatible with both type 1 and type 2 PSEs. The TPS23757's internal softstart permits control of the converter startup preventing the converter from exceeding the PSE output limitations. APb becomes valid within t_{APb} after converter switching starts, or if an adapter is plugged in while the PD is operating from a PSE.

Maintain Power Signature

The MPS is an electrical signature presented by the PD to assure the PSE that it is still present after operating voltage is applied. A valid MPS consists of a minimum dc current of 10 mA (or a 10 mA pulsed current for at least 75 ms every 325 ms) and an ac impedance lower than 26.3 k Ω in parallel with 0.05 μ F. The ac impedance is usually accomplished by the minimum operating C_{IN} requirement of 5 μ F. When either APD or DEN is used to force the hotswap switch off, the dc MPS will not be met. A PSE that monitors the dc MPS will remove power from the PD when this occurs. A PSE that monitors only the ac MPS may remove power from the PD.

Startup and Converter Operation

The internal PoE UVLO (Under Voltage Lock Out) circuit holds the hotswap switch off before the PSE provides full voltage to the PD. This prevents the converter circuits from loading the PoE input during detection and classification. The converter circuits will discharge C_{IN} , C_{VC} , and C_{VB} while the PD is unpowered. Thus $V_{VDD}-V_{RTN}$ will be a small voltage just after full voltage is applied to the PD, as seen in Figure 20. The PSE drives the PI voltage to the operating range once it has decided to power up the PD. When V_{VDD} rises above the UVLO turn-on threshold (V_{UVLO-R} , ~35 V) with RTN high, the TPS23757 enables the hotswap MOSFET with a ~140 mA (inrush) current limit as seen in Figure 21. Converter switching is disabled while C_{IN} charges and V_{RTN} falls from V_{VDD} to nearly V_{VSS} , however the converter startup circuit is allowed to charge C_{VC} (the bootstrap startup capacitor). Additional loading applied between V_{VDD} and V_{RTN} during the inrush state may prevent successful PD and subsequent converter start up. Converter switching is allowed if the PD is not in inrush, converter OTSD (over-temperature shutdown) is not active, and the V_C UVLO permits it. Once the inrush current falls about 10% below the inrush current limit, the PD current limit switches to the operational level (~450 mA). Continuing the startup sequence shown in Figure 21, V_{VC} continues to rise until the startup threshold (V_{CUV} , ~9 V) is exceeded, turning the startup source off and enabling switching. The V_B regulator is always active, powering the internal converter circuits as V_{VC} rises. There is a slight delay between the removal of charge current and the start of switching as the softstart ramp sweeps above the V_{ZDC} threshold. V_{VC} falls as it powers both the internal circuits and the switching MOSFET gates. If the converter control bias output rises to support V_{VC} before it falls to $V_{CUV} - V_{CUVH}$ (~5.5 V), a successful startup occurs. APb in Figure 21 becomes active within t_{APb} from the start of switching, indicating that an adapter is plugged in.

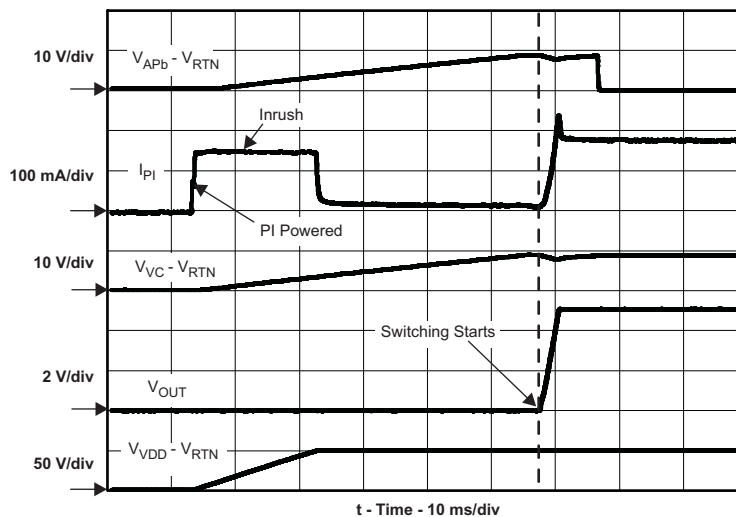

Figure 21. Power Up and Start

If $V_{VDD} - V_{VSS}$ drops below the lower PoE UVLO ($V_{UVLO-R} - V_{UVLO-H}$, ~ 30.5 V), the hotswap MOSFET is turned off, but the converter will still run. The converter will stop if V_{VC} falls below the converter UVLO ($V_{CUV} - V_{CUVH}$, ~ 5.5 V), the hotswap is in inrush current limit, 0% duty cycle is demanded by V_{CTL} ($V_{CTL} < V_{ZDC}$, ~ 1.5 V), or the converter is in thermal shutdown.

PD Hotswap Operation

IEEE 802.3at has taken a new approach to PSE output limiting. A type 2 PSE must meet an output current vs. time template with specified minimum and maximum sourcing boundaries. The peak output current may be as high as 50 A for 10 μ s or 1.75 A for 75 ms. This makes robust protection of the PD device even more important than it was in IEEE 802.3-2008.

The internal hotswap MOSFET is protected against output faults and input voltage steps with a current limit and deglitched (time-delay filtered) foldback. An overload on the pass MOSFET engages the current limit, with $V_{RTN} - V_{VSS}$ rising as a result. If V_{RTN} rises above ~ 12 V for longer than ~ 400 μ s, the current limit reverts to the inrush value, and turns the converter off. The 400 μ s deglitch feature prevents momentary transients from causing a PD reset, provided that recovery lies within the bounds of the hotswap and PSE protection. Figure 22 shows an example of recovery from a 14 V PSE rising voltage step. The hotswap MOSFET goes into current limit, overshooting to a relatively low current, recovers to ~ 450 mA full current limit, and charges the input capacitor while the converter continues to run. The MOSFET did not go into foldback because $V_{RTN} - V_{VSS}$ was below 12 V after the 400 μ s deglitch.

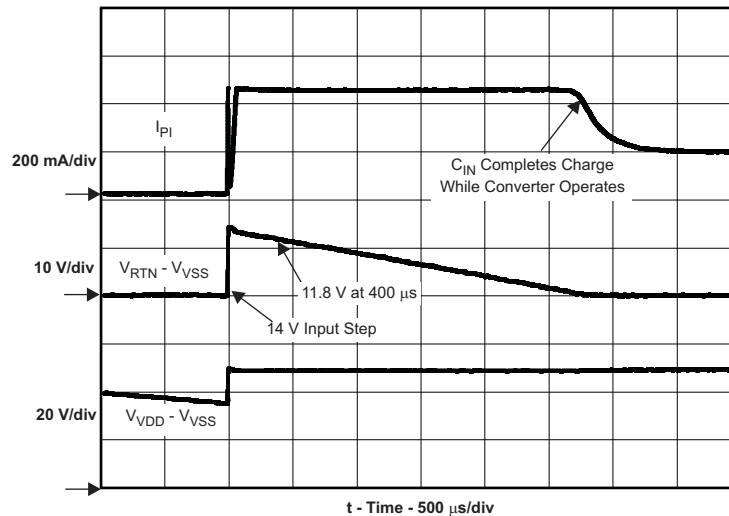

Figure 22. Response to PSE Step Voltage

The PD control has a thermal sensor that protects the internal hotswap MOSFET. Conditions like startup or operation into a V_{DD} to RTN short cause high power dissipation in the MOSFET. An overtemperature shutdown (OTSD) turns off the hotswap MOSFET and class regulator, which are restarted after the device cools. The hotswap MOSFET will be re-enabled with the inrush current limit when exiting from an overtemperature event.

Pulling DEN to V_{SS} during powered operation causes the internal hotswap MOSFET to turn OFF. This feature allows a PD with Option three ORing per Figure 23 to achieve adapter priority. Care must be taken with synchronous converter topologies that can deliver power in both directions.

The hotswap switch will be forced off under the following conditions:

1. V_{APD} above V_{APDEN} (~ 1.5 V)
2. $V_{DEN} < V_{PD-DIS}$ when $V_{VDD} - V_{VSS}$ is in the operational range
3. PD overtemperature
4. $(V_{VDD} - V_{VSS}) < \text{PoE UVLO}$ (~ 30.5 V).

Converter Controller Features

The TPS23757 dc/dc controller implements a typical current-mode control as shown in the Functional Block Diagram. Features include oscillator, overcurrent and PWM comparators, current-sense blanker, dead-time control, softstart, and gate driver. In addition, an internal slope-compensation ramp generator, frequency synchronization logic, thermal shutdown, and startup current source with control are provided.

The TPS23757 is optimized for isolated converters, and does not provide an internal error amplifier. Instead, the optocoupler feedback is directly fed to the CTL pin which serves as a current-demand control for the PWM. There is an offset of V_{ZDC} (~1.5 V) and 2:1 resistor divider between the CTL pin and the PWM. A V_{CTL} below V_{ZDC} will stop converter switching, while voltages above ($V_{ZDC} + (2 \times V_{CSMAX})$) will not increase the requested peak current in the switching MOSFET. Optocoupler biasing design is eased by this limited control range.

Bootstrap Topology

The internal startup current source and control logic implement a bootstrap-type startup as discussed in *Startup and Converter Operation*. The startup current source charges C_{VC} from V_{DD1} when the converter is disabled (either by the PD control or the V_C control) to store enough energy to start the converter. Steady-state operating power must come from a converter (bias winding) output or other source. Loading on V_C and V_B must be minimal while C_{VC} charges, otherwise the converter may never start. The optocoupler will not load V_B when the converter is off for most situations, however care should be taken in ORing topologies where the output is powered when PoE is off.

The converter will shut off when V_C falls below its lower UVLO. This can happen when power is removed from the PD, or during a fault on a converter output rail. When one output is shorted, all the output voltages fall including the one that powers V_C . The control circuit discharges V_C until it hits the lower UVLO and turns off. A restart will initiate as described in *Startup and Converter Operation* if the converter turns off and there is sufficient V_{DD1} voltage. This type of operation is sometimes referred to as *hiccup mode* which provides robust output short protection by providing time-average heating reduction of the output rectifier.

The bootstrap control logic disables most of the converter controller circuits except the V_B regulator and internal reference. Both GATE and GAT2 (assuming GAT2 is enabled) will be low when the converter is disabled. FRS, BLNK, and DT will be at ARTN while the V_C UVLO disables the converter. While the converter runs, FRS, BLNK, and DT will be about 1.25 V.

The startup current source transitions to a resistance as ($V_{DD1} - V_{VC}$) falls below 7 V, but will start the converter from adapters within t_{ST} . The lower test voltage for t_{ST} was chosen based on an assumed adapter tolerance, but is not meant to imply a hard cutoff exists. Startup takes longer and eventually will not occur as V_{DD1} decreases below the test voltage. The bootstrap source provides reliable startup from widely varying input voltages, and eliminates the continual power loss of external resistors. The startup current source will not charge above the maximum recommended V_{VC} if the converter is disabled and there is sufficient V_{DD1} to charge higher.

Current Slope Compensation and Current Limit

Current-mode control requires addition of a compensation ramp to the sensed inductive (transformer or inductor) current for stability at duty cycles near and over 50%. The TPS23757 has a maximum duty cycle limit of 78%, permitting the design of wide input-range flyback and active clamp converters with a lower voltage stress on the output rectifiers. While the maximum duty cycle is 78%, converters may be designed that run at duty cycles well below this for a narrower, 36 V to 57 V PI range. The TPS23757 provides a fixed internal compensation ramp that suffices for most applications.

The TPS23757 provides internal, frequency independent, slope compensation (150 mV, V_{SLOPE}) to the PWM comparator input for current-mode control-loop stability. This voltage is not applied to the current-limit comparator whose threshold is 0.55 V (V_{CSMAX}). If the provided slope is not sufficient, the effective slope may be increased by addition of R_S per [Figure 26](#). The additional slope voltage is provided by ($I_{SL-EX} \times R_S$). There is also a small dc offset caused by the ~2.5 μ A pin current. The peak current limit does not have duty cycle dependency unless R_S is used. This makes it easier to design the current limit to a fixed value. See *Current Slope Compensation* for more information.

The internal comparators monitoring CS are isolated from the IC pin by the blanking circuits while GATE is low, and for a short time (blanking period) just after GATE switches high. A 440 Ω (max) equivalent pull down on CS is applied while GATE is low.

Blanking - R_{BLNK}

The TPS23757 provides a choice between internal fixed and programmable blanking periods. The blanking period is specified as an increase in the minimum GATE on time over the inherent gate driver and comparator delays. The default period (see the Electrical Characteristics table) is selected by connecting BLNK to RTN, and the programmable period is set with R_{BLNK}.

The TPS23757 blanker timing is precise enough that the traditional R-C filters on CS can be eliminated. This avoids current-sense waveform distortion, which tends to get worse at light output loads. There may be some situations or designers that prefer an R-C approach. The TPS23757 provides a pull-down on CS during the GATE off time to improve sensing when an R-C filter must be used. The CS input signal should be protected from nearby noisy signals like GATE drive and the switching MOSFET drain.

Dead Time

The TPS23757 features two switching MOSFET gate drivers to ease implementation of high-efficiency topologies. Specifically, these include active (primary) clamp topologies and those with synchronous drivers that are hard-driven by the control circuit. In all cases, there is a need to assure that both driven MOSFETs are not on at the same time. The DT pin programs a fixed time period delay between the turn-off of one gate driver until the turn-on of the next. This feature is an improvement over the repeatability and accuracy of discrete solutions while eliminating a number of discrete parts on the board. Converter efficiency is tuned with this one repeatable adjustment. The programmed dead time is the same for both GATE-to-GAT2 and GAT2-to-GATE transitions. The dead time period is specified with some capacitive loading and is triggered from internal signals that are several stages back in the driver to eliminate the effects of the gate waveform. The actual dead-time will be somewhat dependent on the gate loading. The turnoff of GAT2 coincides with the start of the internal clock period.

Connecting DT to V_B disables GAT2, which goes to a high-impedance state.

GATE's phase turns the main switch on when it transitions high, and OFF when it transitions low. GAT2's phase turns the second switch OFF when it transitions high, and on when it transitions low. Both switches should be OFF when GAT2 is high and GATE is low. The signal phasing is shown in [Figure 2](#). Many topologies that use secondary-side synchronous rectifiers also use N-Channel MOSFETs driven through a gate-drive transformer. The proper signal phase for these rectifiers may be achieved by inverting the phasing of the secondary winding (swapping the leads). Use of the two gate drives is shown in [Figure 1](#).

FRS and Synchronization

The FRS pin programs the (free-running) oscillator frequency, and may also be used to synchronize the TPS23757 converter to a higher frequency. The internal oscillator sets the maximum duty cycle at 78% and controls the slope-compensation ramp circuit. Synchronization may be accomplished by applying a short pulse (T_{SYNC}) of magnitude V_{SYNC} to FRS as shown in [Figure 25](#). The synchronization pulse terminates the potential on-time period, and the off-time period does not begin until the pulse terminates. Reducing the on-time reduces the available maximum duty cycle.

APb, Startup and Power Management

APb (adapter present) is an active-low multifunction pin that indicates if

$$[(1.5 \text{ V} < V_{APD}) + (1.55 \text{ V} < V_{PPD} \leq 8.3 \text{ V})] \times (V_{CTL} < 4 \text{ V}) \times (\text{pd current limit} \neq \text{Inrush}).$$

The term with V_{CTL} prevents an optocoupler connected to the secondary-side from loading V_C before the converter is started. The APD and PPD terms indicate that an adapter is plugged into the PD, and voltage is present on them. APb permits applications which run from high-power adapters (> 13 W) to detect their presence and adjust the load appropriately. The usage of APb is demonstrated in [Figure 1](#).

Thermal Shutdown

The dc/dc controller has an OTSD that can be triggered by heat sources including the V_B regulator, GATE driver, bootstrap current source, and bias currents. The controller OTSD turns off V_B, the GATE driver, and forces the V_C control into an undervoltage state.

Adapter ORing

Many PoE-capable devices are designed to operate from either a wall adapter or PoE power. A local power solution adds cost and complexity, but allows a product to be used if PoE is not available in a particular installation. While most applications only require that the PD operate when both sources are present, the TPS23757 supports forced operation from either of the power sources. Figure 23 illustrates three options for diode ORing external power into a PD. Only one option would be used in any particular design. Option 1 applies power to the TPS23757 PoE input, option 2 applies power between the TPS23757 PoE section and the dc/dc converter, and option 3 applies power to the output side of the converter. Each of these options has advantages and disadvantages. Many of the basic ORing configurations and discussion contained in application note *Advanced Adapter ORing Solutions using the TPS23753* (literature number [SLVA306](#)), apply to the TPS23757.

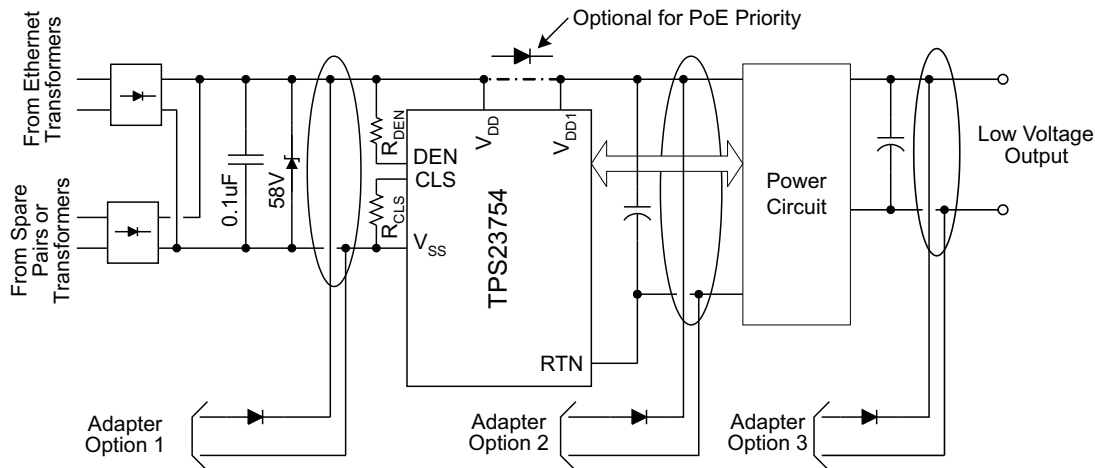

Figure 23. ORing Configurations

The IEEE standards require that the Ethernet cable be isolated from ground and all other system potentials. The adapter must meet a minimum 1500 Vac dielectric withstand test between the output and all other connections for ORing options 1 and 2. The adapter only needs this isolation for option 3 if it is not provided by the converter.

Adapter ORing diodes are shown for all the options to protect against a reverse voltage adapter, a short on the adapter input pins, and damage to a low-voltage adapter. ORing is sometimes accomplished with a MOSFET in option 3.

PPD ORing Features

The TPS23757 provides several additional features for the ORing based on the multifunction PPD pin. These include APb signaling of an option 1 adapter, use of a 24 V adapter (reduced output power) for option 1, and use of PoE as a power backup in conjunction with option 2. See the *Advanced ORing Techniques* section.

Using DEN to disable PoE

The DEN pin may be used to turn the PoE hotswap switch OFF by pulling it to V_{SS} while in the operational state, or to prevent detection when in the idle state. A low on DEN forces the hotswap MOSFET OFF during normal operation. Additional information is available in *Advanced Adapter ORing Solutions using the TPS23753* (literature number [SLVA306](#)).

ORing Challenges

Preference of one power source presents a number of challenges. Combinations of adapter output voltage (nominal and tolerance), power insertion point, and which source is preferred determine solution complexity. Several factors adding to the complexity are the natural high-voltage selection of diode ORing (the simplest method of combining sources), the current limit implicit in the PSE, and PD inrush and protection circuits (necessary for operation and reliability). Creating simple and seamless solutions is difficult if not impossible for many of the combinations. However the TPS23757 offers several built-in features that simplify some combinations.

Several examples will demonstrate the limitations inherent in ORing solutions. Diode ORing a 48 V adapter with PoE (option 1) presents the problem that either source might be higher. A blocking switch would be required to assure which source was active. A second example is combining a 12 V adapter with PoE using option 2. The converter will draw approximately four times the current at 12 V from the adapter than it does from PoE at 48 V. Transition from adapter power to PoE may demand more current than can be supplied by the PSE. The converter must be turned off while C_{IN} capacitance charges, with a subsequent converter restart at the higher voltage and lower input current. A third example is use of a 12 V adapter with ORing option 1. The PD hotswap would have to handle four times the current, and have 1/16 the resistance (be 16 times larger) to dissipate equal power. A fourth example is that MPS is lost when running from the adapter, causing the PSE to remove power from the PD. If ac power is then lost, the PD will stop operating until the PSE detects and powers the PD.

APPLICATION INFORMATION

The TPS23757 will support many power supply topologies that require a single PWM gate drive or two complementary gate drives and will operate with current-mode control. [Figure 1](#) provides an example of a flyback with a driven output synchronous rectifier. The TPS23757 may be used in topologies that do not require GAT2, which may be disabled to reduce its idling loss.

Selecting a converter topology along with a design procedure is beyond the scope of this applications section. Examples to help in programming the TPS23757 are shown below. Additional special topics are included to explain the ORing capabilities, frequency dithering, and other design considerations.

For more specific converter design examples refer to the following application notes:

- Designing with the TPS23753 Powered Device and Power Supply Controller, [SLVA305](#)
- Understanding and Designing an Active Clamp Current Mode Controlled Converter Using the UCC2897A. [SLUA535](#)
- Advanced Adapter ORing Solutions using the TPS23753, [SLVA306A](#)
- TPS23757EVM: Evaluation Module for TPS23757, [SLVU318](#)

Input Bridges and Schottky Diodes

Using Schottky diodes instead of PN junction diodes for the PoE input bridges and D_{VDD} will reduce the loss of this function by about 30%. There are however some things to consider when using them.

The IEEE standard specifies a maximum backfeed voltage of 2.8 V. A 100 k Ω resistor is placed between the unpowered pairs and the voltage is measured across the resistor. Schottky diodes often have a higher reverse leakage current than PN diodes, making this a harder requirement to meet. Use conservative design for diode operating temperature, select lower-leakage devices where possible, and match leakage and temperatures by using packaged bridges to help with this.

Schottky diode leakage current and lower dynamic resistance can impact the detection signature. Setting reasonable expectations for the temperature range over which the detection signature is accurate is the simplest solution. Increasing R_{DEN} slightly may also help meet the requirement.

Schottky diodes have proven less robust to the stresses of ESD transients, failing as a short or becoming leaky. Care must be taken to provide adequate protection in line with the exposure levels. This protection may be as simple as ferrite beads and capacitors.

A general recommendation for the input rectifiers are 1 A or 2 A, 100 V rated discrete or bridge diodes.

Protection, D1

A TVS, D_1 , across the rectified PoE voltage per [Figure 24](#) must be used. An SMAJ58A, or a part with equal to or better performance, is recommended for general indoor applications. If an adapter is connected from V_{DD1} to RTN, as in ORing option 2 above, voltage transients caused by the input cable inductance ringing with the internal PD capacitance can occur. Adequate capacitive filtering or a TVS must limit this voltage to be within the absolute maximum ratings. Outdoor transient levels or special applications require additional protection.

Use of diode D_{VDD} for PoE priority may dictate the use of additional protection around the TPS23757. ESD events between the PD power inputs (PoE and adapter), or the inputs and converter output, cause large stresses in the hotswap MOSFET if D_{VDD} becomes reverse biased and transient current around the TPS23757 is blocked. The use of C_{VDD} and D_{RTN} in Figure 24 provides additional protection should over-stress of the TPS23757 be an issue. An SMAJ58A would be a good initial selection for D_{RTN} . Individual designs may have to tune the value of C_{VDD} .

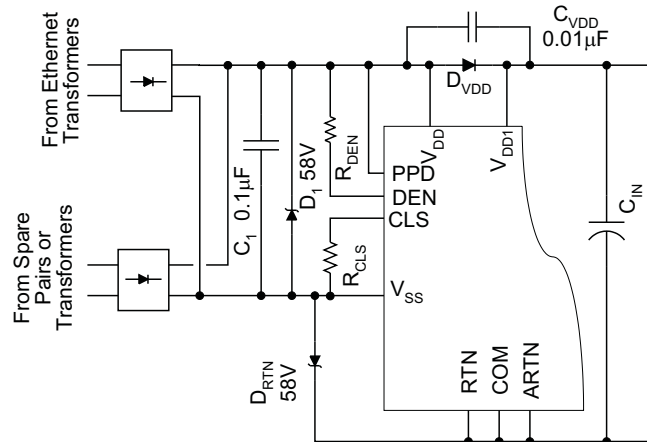

Figure 24. Example of Added ESD Protection for PoE Priority

Capacitor, C_1

The standard specifies an input bypass capacitor (from V_{DD} to V_{SS}) of 0.05 μF to 0.12 μF . Typically a 0.1 μF , 100 V, 10% ceramic capacitor is used.

Detection Resistor, R_{DEN}

The standard specifies a detection signature resistance, R_{DEN} between 23.7 k Ω and 26.3 k Ω , or 25 k $\Omega \pm 5\%$. Choose an R_{DEN} of 24.9 k Ω .

Classification Resistor, R_{CLS}

Connect a resistor from CLS to V_{SS} to program the classification current according to the IEEE 802.3at standard. The class power assigned should correspond to the maximum average power drawn by the PD during operation. Select R_{CLS} according to Table 1. The TPS23757 should not use class 4 as its input current is limited to class 3 (and lower) levels. Apart from power above 13W, there is no advantage to type 2 operation.

APD Pin Divider Network, R_{APD1} , R_{APD2}

The APD pin can be used to disable the TPS23757 internal hotswap MOSFET giving the adapter source priority over the PoE source. An example calculation is provided in (TI literature number) [SLVA306A](#).

PPD Pin Divider Network, R_{PPD1} , R_{PPD2}

The PPD pin can be used to override the internal hotswap MOSFET UVLO (UVLO_R and UVLO_H) when using low voltage adapters connected between V_{DD} and V_{SS} . The PPD pin has an internal 5 μA pulldown current source. As an example, consider the choice of R_{PPD1} and R_{PPD2} , for a 24 V adapter.

1. Select the startup voltage, $V_{ADPTR-ON}$ approximately 75% of nominal for a 24 V adapter. Assuming that the adapter output is 24 V \pm 10%, this provides 15% margin below the minimum adapter operating voltage.
2. Choose $V_{ADPTR-ON} = 24 \text{ V} \times 0.75 = 18 \text{ V}$
3. Choose $R_{PPD2} = 3.01 \text{ k}\Omega$
4. Calculate R_{PPD1}

$$R_{PPD1} = \left(\frac{V_{ADPTR_ON} - V_{PPDEN}}{\frac{V_{PPDEN}}{R_{PPD2}} + I_{PPD}} \right) = \left(\frac{18\text{ V} - 1.55\text{ V}}{\frac{1.55\text{ V}}{3.01\text{ k}\Omega} + 5\text{ }\mu\text{A}} \right) = 31.64\text{ k}\Omega$$

(a)

(b) Choose $R_{PPD1} = 32.4\text{ k}\Omega$

5. Check PPD turn on and PPD turn off voltages

$$V_{ADPTR_ON} = V_{PPDEN} + \left[R_{PPD1} \times \left(\frac{V_{PPDEN}}{R_{PPD2}} + I_{PPD} \right) \right] = 18.4\text{ V}$$

(a)

$$V_{ADPTR_OFF} = (V_{PPDEN} - V_{PPDH}) + \left[R_{PPD1} \times \left(\frac{(V_{PPDEN} - V_{PPDH})}{R_{PPD2}} + I_{PPD} \right) \right] = 14.75\text{ V}$$

(b)

(c) Voltages look acceptable.

6. Check PPD resistor power consumption.

$$P_{RPPD} = \frac{(V_{DD} - V_{SS})^2}{R_{PPD1} + R_{PPD2}} = \frac{(24\text{ V} \times 1.1)^2}{3.01\text{ k}\Omega + 32.4\text{ k}\Omega} = 19.6\text{ mW}$$

(a)

(b) Power is acceptable, but resistor values could be increased to reduce the power loss.

The PPD pin can also be used to modify the internal MOSFET UVLO for use with a lower output voltage PSE (within certain limits). Connect the R_{PPD1} and R_{PPD2} dividers directly between VDD and VSS with the midpoint connected to PPD. For this case and in order to allow classification, target the minimum PSE OFF voltage (V_{ADPTR_OFF}) $> V_{CU_OFF} = 23\text{ V}$. Then follow the procedure outlined above to select R_{PPD1} , R_{PPD2} , and determine the PSE ON (V_{ADPTR_ON}) and PSE OFF (V_{ADPTR_OFF}) voltages ensuring that PSE OFF $> 23\text{ V}$. Lastly, since the R_{PPD1}/R_{PPD2} divider is in parallel with R_{DEN} during detection, R_{DEN} must be increased such that the equivalent detection resistance is $25\text{ k}\Omega$ nominal.

Setting Frequency (R_{FRS}) and Synchronization

The converter switching frequency is set by connecting R_{FRS} from the FRS pin to ARTN. The frequency may be set as high as 1 MHz with some loss in programming accuracy as well as converter efficiency. Synchronization at high duty cycles may become more difficult above 500 kHz due to the internal oscillator delays reducing the available on-time. As an example:

1. Assume a desired switching frequency (f_{SW}) of 250 kHz.
2. Compute R_{FRS} :

$$R_{FRS}(\text{k}\Omega) = \frac{17250}{f_{SW}(\text{kHz})} = \frac{17250}{250} = 69$$

(a)

(b) Select 69.8 k Ω .

The TPS23757 may be synchronized to an external clock to eliminate beat frequencies from a sampled system, or to place emission spectrum away from an RF input frequency. Synchronization may be accomplished by applying a short pulse (T_{SYNC}) of magnitude V_{SYNC} to FRS as shown in [Figure 25](#). R_{FRS} should be chosen so that the maximum free-running frequency is just below the desired synchronization frequency. The synchronization pulse terminates the potential on-time period, and the off-time period does not begin until the pulse terminates. The pulse at the FRS pin should reach between 2.5 V and V_B , with a minimum width of 22 ns (above 2.5 V) and rise/fall times less than 10 ns. The FRS node should be protected from noise because it is high-impedance. An R_T on the order of 100 Ω in the isolated example reduces noise sensitivity and jitter.

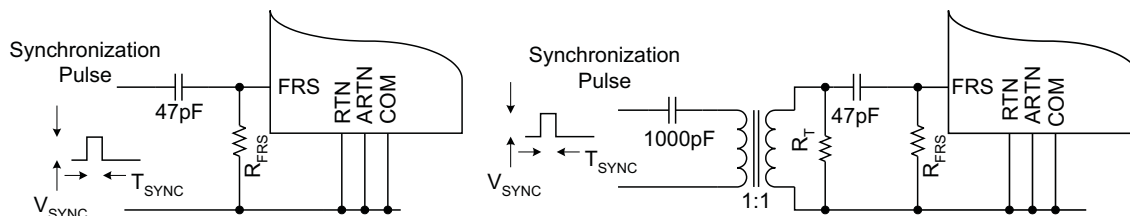
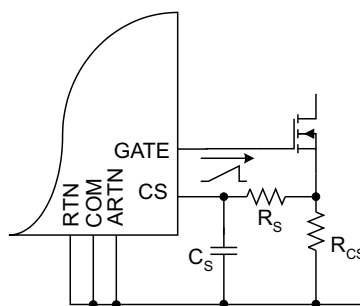

Figure 25. Synchronization

Current Slope Compensation

The TPS23757 provides a fixed internal compensation ramp that suffices for most applications. R_S (see [Figure 26](#)) may be used if the internally provided slope compensation is not enough.

Most current-mode control papers and application notes define the slope values in terms of V_{PP}/t_S (peak ramp voltage / switching period), however the electrical characteristics table specifies the slope peak (V_{SLOPE}) based on the maximum (78%) duty cycle. Assuming that the desired slope, V_{SLOPE_D} (in mV/period), is based on the full period, compute R_S per the following equation where V_{SLOPE} , D_{MAX} , and I_{SL_EX} are from the electrical characteristics table with voltages in mV, current in μA , and the duty cycle is unitless (e.g., $D_{MAX} = 0.78$).

$$R_S (\Omega) = \frac{\left[V_{SLOPE_D} (\text{mV}) - \left(\frac{V_{SLOPE} (\text{mV})}{D_{MAX}} \right) \right]}{I_{SL_EX} (\mu A)} \times 1000 \quad (6)$$

Figure 26. Additional Slope Compensation

C_S may be required if the presence of R_S causes increased noise, due to adjacent signals like the gate drive, to appear at the C_S pin.

Blanking Period, R_{BLNK}

Selection of the blanking period is often empirical because it is affected by parasitics and thermal effects of every device between the gate-driver and output capacitors. The minimum blanking period prevents the current limit and PWM comparators from being falsely triggered by the inherent current spike that occurs when the switching MOSFET turns on. The maximum blanking period is bounded by the output rectifier's ability to withstand the currents experienced during a converter output short, and the minimum duty cycle required.

If blanking beyond the internal default is desired choose R_{BLNK} using $R_{BLNK} (\text{k}\Omega) = t_{BLNK} (\text{ns})$.

1. For a 100 ns blanking interval
 - (a) $R_{BLNK} (\text{k}\Omega) = 100$
 - (b) Choose $R_{BLNK} = 100 \text{ k}\Omega$.

The blanking interval can also be chosen as a percentage of the switching period.

1. Compute R_{BLNK} as follows for 2% blanking interval in a switcher running at 250 kHz.

$$R_{\text{BLNK}} (\text{k}\Omega) = \frac{\text{Blanking_Interval}(\%)}{f_{\text{SW}} (\text{kHz})} \times 10^4 = \frac{2}{250} \times 10^4 = 80$$

(a)

(b) Select $R_{\text{BLNK}} = 80.6 \text{ k}\Omega$.

Dead Time Resistor, R_{DT}

The required dead time period depends on the specific topology and parasitics. To obtain the optimum timing resistor, build the supply and tune the dead time to achieve the best efficiency after considering all corners of operation (load, input voltage, and temperature). A good initial value is 100 ns. Program the dead time with a resistor connected from DT to ARTN per Equation 3. Efficiency optimization may be performed by substituting a potentiometer (POT) for R_{DT} , and adjusting its value to obtain a minimum input current at the desired operating load.

1. Choose R_{DT} as follows assuming a t_{DT} of 100 ns:

$$R_{\text{DT}} (\text{k}\Omega) = \frac{t_{\text{DT}} (\text{ns})}{2} = \frac{100}{2} = 50$$

(a)

(b) Choose $R_{\text{DT}} = 49.9 \text{ k}\Omega$

Estimating Bias Supply Requirements and C_{VC}

The bias supply (V_{C}) power requirements determine the C_{VC} sizing and frequency of hiccup during a fault. The first step is to determine the power/current requirements of the power supply control, then use this to select C_{VC} . The control current draw will be assumed constant with voltage to simplify the estimate, resulting in an approximate value.

First determine the switching MOSFET gate drive power.

1. Let V_{QG} be the gate voltage swing that the MOSFET Q_{G} is rated to (often 10 V).

$$P_{\text{GATE}} = V_{\text{C}} \times f_{\text{SW}} \times \left(Q_{\text{GATE}} \times \frac{V_{\text{C}}}{V_{\text{QG}}} \right) \quad P_{\text{GAT2}} = V_{\text{C}} \times f_{\text{SW}} \times \left(Q_{\text{GATE2}} \times \frac{V_{\text{C}}}{V_{\text{QG}}} \right)$$

(a)

- (b) Compute gate drive power if V_{C} is 10 V, the switching frequency is 250 kHz, Q_{GATE} is 17 nC, and Q_{GAT2} is 8 nC.

$$P_{\text{GATE}} = 10 \text{ V} \times 250 \text{ kHz} \times 17 \text{ nC} \times \frac{10}{10} = 42.5 \text{ mW}$$

$$P_{\text{GAT2}} = 10 \text{ V} \times 250 \text{ kHz} \times 8 \text{ nC} \times \frac{10}{10} = 20 \text{ mW}$$

(c)

$$P_{\text{DRIVE}} = 42.5 \text{ mW} + 20 \text{ mW} = 62.5 \text{ mW}$$

- (d) This illustrates why MOSFET Q_{G} should be an important consideration in selecting the switching MOSFETs.

2. Estimate the required bias current at some intermediate voltage during the C_{VC} discharge. For the TPS23757, 7.5 V provides a reasonable estimate. Add the operating bias current to the gate drive current.

$$I_{\text{DRIVE}} = \frac{P_{\text{DRIVE}}}{V_{\text{C}}} \times \frac{V_{\text{DIS}}}{V_{\text{C}}} = \frac{62.5 \text{ mW}}{10 \text{ V}} \times \frac{7.5 \text{ V}}{10 \text{ V}} = 4.7 \text{ mA}$$

(a)

$$I_{\text{TOTAL}} = I_{\text{DRIVE}} + I_{\text{OPERATING}} = 4.7 \text{ mA} + 0.92 \text{ mA} = 5.6 \text{ mA}$$

(b)

3. Compute the required C_{VC} based on startup within the typical softstart period of 4 ms.

$$C_{\text{VC1}} + C_{\text{VC2}} = \frac{t_{\text{STARTUP}} \times I_{\text{TOTAL}}}{V_{\text{CUVH}}} = \frac{4 \text{ ms} \times 5.6 \text{ mA}}{3.5 \text{ V}} = 6.4 \text{ }\mu\text{F}$$

(a)

- (b) For this case, a standard 10 μF electrolytic plus a 0.47 μF should be sufficient. In practice this is conservative since it was assumed it would take the full 4 ms to start up.

4. Compute the initial time to start the converter when operating from PoE.

- (a) Using a typical bootstrap current of 4 mA, compute the time to startup.

$$t_{\text{ST}} = \frac{C_{\text{VC}} \times V_{\text{CUV}}}{I_{\text{VC}}} = \frac{10.47 \text{ }\mu\text{F} \times 9 \text{ V}}{4 \text{ mA}} = 23.6 \text{ ms}$$

(b)

5. Compute the fault duty cycle and hiccup frequency

$$(a) \quad t_{\text{RECHARGE}} = \frac{(C_{\text{VC1}} + C_{\text{VC2}}) \times V_{\text{CUVH}}}{I_{\text{VC}}} = \frac{(10 \mu\text{F} + 0.47 \mu\text{F}) \times 3.5 \text{ V}}{4 \text{ mA}} = 9.2 \text{ ms}$$

$$(b) \quad t_{\text{DISCHARGE}} = \frac{(C_{\text{VC1}} + C_{\text{VC2}}) \times V_{\text{CUVH}}}{I_{\text{TOTAL}}} = \frac{(10 \mu\text{F} + 0.47 \mu\text{F}) \times 3.5 \text{ V}}{5.6 \text{ mA}} = 6.5 \text{ ms}$$

(a) Note that the optocoupler current is 0 mA because the output is in current limit.

(b) Also, it is assumed I_{APb} is 0 mA.

$$(c) \quad \text{Duty Cycle: } D = \frac{t_{\text{DISCHARGE}}}{t_{\text{DISCHARGE}} + t_{\text{RECHARGE}}} = \frac{6.5 \text{ ms}}{6.5 \text{ ms} + 9.2 \text{ ms}} = 41\%$$

$$(d) \quad \text{Hiccup Frequency: } F = \frac{1}{t_{\text{DISCHARGE}} + t_{\text{RECHARGE}}} = \frac{1}{6.5 \text{ ms} + 9.2 \text{ ms}} = 64 \text{ Hz}$$

6. The voltage rating of C_{VC1} and C_{VC2} should be 16 V minimum.

Switching Transformer Considerations and R_{VC}

Care in design of the transformer and V_{C} bias circuit is required to obtain hiccup overload protection. Leading-edge voltage overshoot on the bias winding may cause V_{C} to peak-charge, preventing the expected tracking with output voltage. Some method of controlling this is usually required. This may be as simple as a series resistor, or an R-C filter in front of D_{VC1} . Good transformer bias-to-output-winding coupling results in reduced overshoot and better voltage tracking.

R_{VC} as shown in Figure 27 helps to reduce peak charging from the bias winding. This becomes especially important when tuning hiccup mode operation during output overload. Typical values for R_{VC} will be between 10 Ω and 100 Ω .

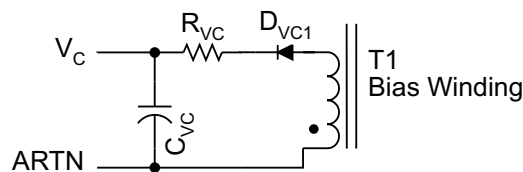

Figure 27. R_{VC} Usage

APb Pin Interface

The APb pin is an active low, open-drain output indicating an adapter power source is available. An optocoupler is typically used to interface with the APb pin to signal equipment on the secondary side of the converter of APb status. Optocoupler current-gain is referred to as CTR (current transfer ratio), which is the ratio of transistor collector current to LED current. To preserve efficiency, a high-gain optocoupler ($250\% \leq \text{CTR} \leq 500\%$, or $300\% \leq \text{CTR} \leq 600\%$) along with a high-impedance (e.g., CMOS) receiver are recommended. Design of the APb optocoupler interface can be accomplished as follows:

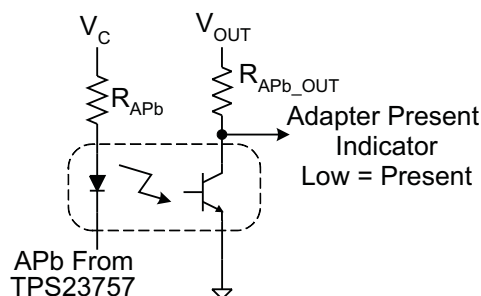

Figure 28. APb Interface

1. APb ON characteristic: $I_{\text{APb}} = 2 \text{ mA}$ minimum, $V_{\text{APb}} = 1 \text{ V}$
2. Let $V_{\text{C}} = 12 \text{ V}$, $V_{\text{OUT}} = 5 \text{ V}$, $R_{\text{APb-OUT}} = 10 \text{ k}\Omega$, $V_{\text{APb-OUT}} (\text{low}) = 400 \text{ mV}$ max

$$I_{APb} = \frac{V_{OUT} - V_{APb}(low)}{R_{APb}} = \frac{5 - 0.4}{10000} = 0.46 \text{ mA}$$

(a)

3. The optocoupler CTR will be needed to determine R_{APb} . A device with a minimum CTR of 300% at 5 mA LED bias current is selected. CTR will also vary with temperature and LED bias current. The strong variation of CTR with diode current makes this a problem that requires some iteration using the CTR versus I_{DIODE} curve on the optocoupler data sheet.

(a) Using the (normalized) curves, a current of 0.4 mA to 0.5 mA is required to support the output current at the minimum CTR at 25°C.

(a) Pick an I_{DIODE} . For example one around the desired load current.

(b) Use the optocoupler datasheet curve to determine the effective CTR at this operating current. It is usually necessary to apply the normalized curve value to the minimum specified CTR. It might be necessary to ratio or offset the curve readings to obtain a value that is relative to the current that the CTR is specified at.

(c) If $I_{DIODE} \times CTR_{I_{DIODE}}$ is substantially different from I_{RAPb_OUT} , choose another I_{DIODE} and repeat.

(b) This manufacturer's curves also indicate a -20% variation of CTR with temperature. The approximate forward voltage of the optocoupler diode is 1.1 V from the data sheet.

$$I_{APb} \cong I_{MIN} \times \frac{100}{100 - \Delta CTR_{TEMP}} = 0.5 \text{ mA} \times \frac{100}{100 - 20} = 0.625 \text{ mA}$$

(c) $V_{FLED} \cong 1.1 \text{ V}$

$$R_{APb} = \frac{V_C - V_{APb} - V_{FLED}}{I_{APb}} = \frac{12 - 1 - 1.1}{0.625 \text{ mA}} = 15.48 \text{ k}\Omega$$

(d) Select a 15.4 kΩ resistor. Even though the minimum CTR and temperature variation were considered, the designer might choose a smaller resistor for a little more margin.

Advanced ORing Techniques

See *Advanced Adapter ORing Solutions using the TSP23753*, TI literature number [SLVA306A](#) for ORing applications that also work with the TPS23757. The material in sections *Adapter ORing* and *Protection, D1* are important to consider as well. The following applications are supported with the introduction of PPD.

Option 2 ORing with PoE acting as a hot backup is eased by connecting PPD to V_{DD} per [Figure 29](#). This PPD connection enables the class regulator even when APD is high. The R-Zener network (1.8 kΩ – 24 V) is the simplest circuit that will satisfy MPS requirements, keeping the PSE online. This network may be switched out when APD is not powered with an optocoupler. This works best with a 48-V adapter and the APD-programmed threshold as high as possible. An example of an adapter priority application with smooth switchover between a 48 V adapter and PoE is shown on the right side of [Figure 29](#). D_{APD} is used to reduce the effective APD hysteresis, allowing the PSE to power the load before $V_{VDD1} - V_{RTN}$ falls too low and causes a hotswap foldback.

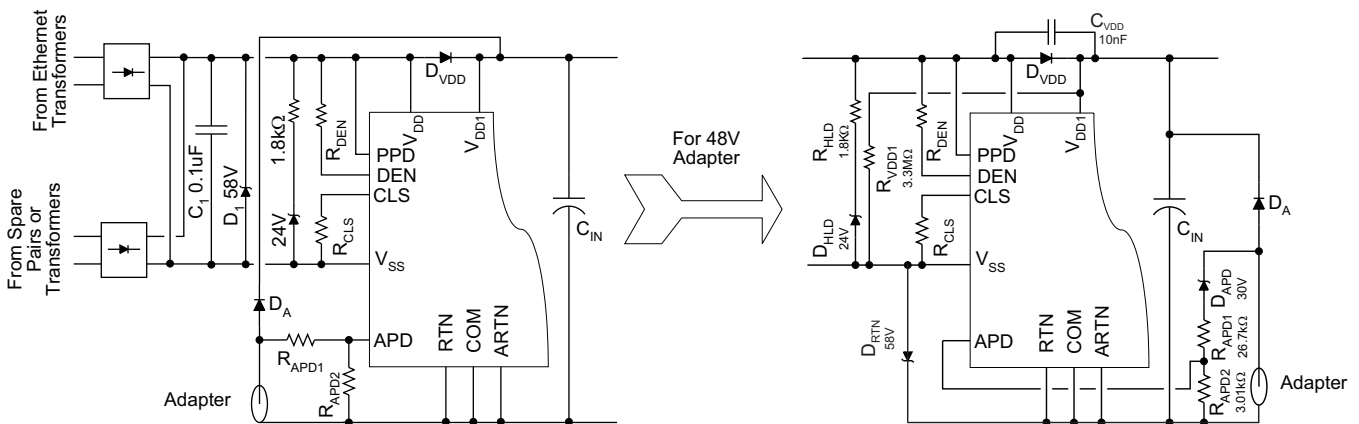

Figure 29. Option 2 PoE Backup ORing

Option 1 ORing of a low voltage adapter (e.g., 24 V) is possible by connecting a resistor divider to PPD as in [Figure 30](#). When $1.55\text{ V} \leq V_{PPD} \leq 8.3\text{ V}$, the hotswap MOSFET is enabled, APb is activated, and the class feature is disabled. The hotswap current limit is unaffected, limiting the available power. For example, the maximum input power from a 24 V adapter would be 9.3 W $[(24\text{ V} - 0.6\text{ V}) \times 0.4\text{ A}]$.

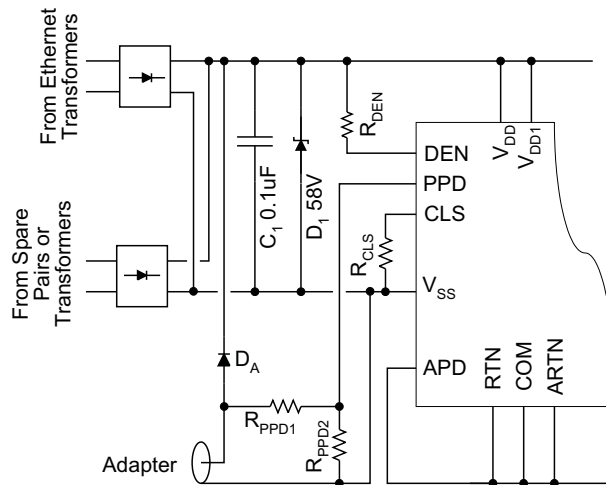

Figure 30. Low-Voltage Option 1 ORing

Softstart

Converters require a softstart on the voltage error amplifier to prevent output overshoot on startup. [Figure 31](#) shows a common implementation of a secondary-side softstart that works with the typical TLV431 error amplifier. The softstart components consist of D_{SS} , R_{SS} , and C_{SS} . They serve to control the output rate-of-rise by pulling V_{CTL} down as C_{SS} charges through R_{OB} , the optocoupler, and D_{SS} . This has the added advantage that the TLV431 output and C_{IZ} are preset to the proper value as the output voltage reaches the regulated value, preventing voltage overshoot due to the error amplifier recovery. The secondary-side error amplifier will not become active until there is sufficient voltage on the secondary. The TPS23757 provides a primary-side softstart which persists long enough ($\sim 4\text{ ms}$) for secondary side voltage-loop softstart to take over. The primary-side current-loop softstart controls the switching MOSFET peak current by applying a slowly rising ramp voltage to a second PWM control input. The PWM is controlled by the lower of the softstart ramp or the CTL-derived current demand. The actual output voltage rise time is usually much shorter than the internal softstart period. Initially the internal softstart ramp limits the maximum current demand as a function of time. Either the current limit, secondary-side softstart, or output regulation assume control of the PWM before the internal softstart period is over. [Figure 21](#) shows a smooth handoff between the primary and secondary-side softstart with minimal output voltage overshoot.

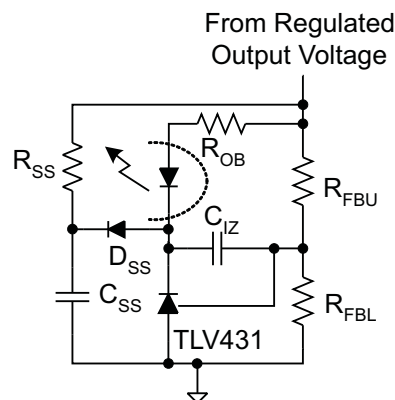

Figure 31. Error Amplifier Soft Start

Special Switching MOSFET Considerations

Special care must be used in selecting the converter switching MOSFET. The TPS23757 minimum switching MOSFET V_{GATE} is ~5.5 V, which is due to the V_C lower threshold. This will occur during an output overload, or towards the end of a (failed) bootstrap startup. The MOSFET must be able to carry the anticipated peak fault current at this gate voltage.

Thermal Considerations and OTSD

Sources of nearby local PCB heating should be considered during the thermal design. Typical calculations assume that the TPS23757 is the only heat source contributing to the PCB temperature rise. It is possible for a normally operating TPS23757 device to experience an OTSD event if it is excessively heated by a nearby device.

Frequency Dithering for Conducted Emissions Control

The international standard CISPR 22 (and adopted versions) is often used as a requirement for conducted emissions. Ethernet cables are covered as a telecommunication port under section 5.2 for conducted emissions. Meeting EMI requirements is often a challenge, with the lower limits of Class B being especially hard. Circuit board layout, filtering, and snubbing various nodes in the power circuit are the first layer of control techniques. A more detailed discussion of EMI control is presented in *Practical Guidelines to Designing an EMI Compliant PoE Powered Device With Isolated Flyback*, TI literature number [SLUA469](#). Additionally, IEEE802.3at sections 33.3 and 33.4 have requirements for noise injected onto the Ethernet cable based on compatibility with data transmission.

Occasionally, a technique referred to as frequency dithering is utilized to provide additional EMI measurement reduction. The switching frequency is modulated to spread the narrowband individual harmonics across a wider bandwidth, thus lowering peak measurements. The circuit of [Figure 32](#) modulates the switching frequency by feeding a small ac signal into the FRS pin. These values may be adapted to suit individual needs.

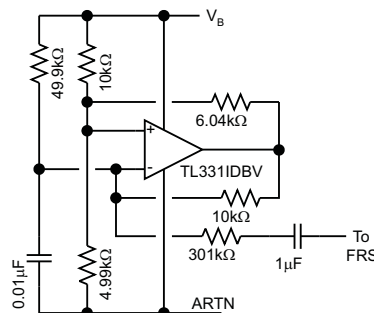

Figure 32. Frequency Dithering

ESD

The TPS23757 has been tested to EN61000-4-2 using a power supply based on [Figure 1](#). The levels used were 8 kV contact discharge and 15 kV air discharge. Surges were applied between the PoE input and the dc output, between the adapter input and the dc output, between the adapter and the PoE inputs, and to the dc output with respect to earth. Tests were done both powered and unpowered. No TPS23757 failures were observed and operation was continuous. See [Figure 24](#) for additional protection for some test configurations.

ESD requirements for a unit that incorporates the TPS23757 have a much broader scope and operational implications than are used in TI's testing. Unit-level requirements should not be confused with reference design testing that only validates the ruggedness of the TPS23757.

Layout

Printed circuit board layout recommendations are provided in the evaluation module (EVM) documentation available for these devices.

REVISION HISTORY

Changes from Revision Original (August 2009) to Revision A **Page**

- Changed the ESDS statement. 2
-

Changes from Revision A (September 2009) to Revision B **Page**

- Changed From: IEEE 802.3at (draft) To: IEEE 802.3at throughout the data sheet 1
 - Changed the Thermal resistance note in the DISSIPATION RATINGS table to include additional information 3
 - Changed [Table 1](#) - Notes for the Class 4 row. 8
 - Changed the section - Using DEN to disable PoE 22
-

Changes from Revision B (December 2009) to Revision C **Page**

- Changed the application report From: SLAU303 To: SLAU535 23
-

Changes from Revision C (June 2012) to Revision D **Page**

- Changed [Table 1](#), Class 0 and Class 3 Max From: 12.95 To: 13; Class 4 Min From: 12.95 To: 13 8
 - Changrd [Equation 5](#), From: $-I_{PPD}$ To: $+I_{PPD}$ 9
 - Changed [Table 2](#), PD INPUT POWER (max) From: 12.92(13) W To 13 W; POWER \leq 12.95 W To: \leq 13 W, and POWER $>$ 12.95 W To: $>$ 13 W 16
 - Changed text in the Detection section From: "($\Delta V / \Delta I$) between 23.75 k Ω and 26.25 k Ω at the PI." To: "($\Delta V / \Delta I$) between 23.7 k Ω and 26.3 k Ω at the PI." 17
 - Changed text in the Maintain Power Signature section From: "75 ms every 225 ms) and an ac impedance lower than 26.25 k Ω in parallel with 0.05 μ F" To: "75 ms every 325 ms) and an ac impedance lower than 26.3 k Ω in parallel with 0.05 μ F" 18
 - Added text to the Startup and Converter Operation: "Additional loading applied between V_{VDD} and V_{RTN} during the inrush state may prevent successful PD and subsequent converter start up." 18
 - Changrd text in the Detection Resistor, R_{DEN} From: "between 23.75 k Ω and 26.25 k Ω , or 25 k $\Omega \pm 5\%$: To: ".between 23.7 k Ω and 26.3 k Ω , or 25 k $\Omega \pm 5\%$ " 24
 - Changed the equation for Calculate R_{PPD1} . From: $-I_{PPD}$ to: $+I_{PPD}$, From: -5μ A to $+5 \mu$ A, and From: $= 32.26$ To: $= 31.64$ 25
 - Changed the equation for Check PPD turn on and PPD turn off voltages (a), From: $-I_{PPD}$ to: $+I_{PPD}$, and From: $= 18.07$ To: $= 18.4$ 25
 - Changed the equation for Check PPD turn on and PPD turn off voltages (b), From: $-I_{PPD}$ to: $+I_{PPD}$, and From: $= 14.54$ To: $= 14.75$ 25
 - Added text to the end of the PPD Pin Divider Network, R_{PPD1} , R_{PPD2} section 25
-

PACKAGING INFORMATION

Orderable Device	Status (1)	Package Type	Package Drawing	Pins	Package Qty	Eco Plan (2)	Lead/Ball Finish (6)	MSL Peak Temp (3)	Op Temp (°C)	Device Marking (4/5)	Samples
TPS23757PW	ACTIVE	TSSOP	PW	20	70	Green (RoHS & no Sb/Br)	CU NIPDAU	Level-2-260C-1 YEAR	-40 to 125	TPS23757	Samples
TPS23757PWR	ACTIVE	TSSOP	PW	20	2000	Green (RoHS & no Sb/Br)	CU NIPDAU	Level-2-260C-1 YEAR	-40 to 125	TPS23757	Samples

(1) The marketing status values are defined as follows:

ACTIVE: Product device recommended for new designs.

LIFEBUY: TI has announced that the device will be discontinued, and a lifetime-buy period is in effect.

NRND: Not recommended for new designs. Device is in production to support existing customers, but TI does not recommend using this part in a new design.

PREVIEW: Device has been announced but is not in production. Samples may or may not be available.

OBsolete: TI has discontinued the production of the device.

(2) Eco Plan - The planned eco-friendly classification: Pb-Free (RoHS), Pb-Free (RoHS Exempt), or Green (RoHS & no Sb/Br) - please check <http://www.ti.com/productcontent> for the latest availability information and additional product content details.

TBD: The Pb-Free/Green conversion plan has not been defined.

Pb-Free (RoHS): TI's terms "Lead-Free" or "Pb-Free" mean semiconductor products that are compatible with the current RoHS requirements for all 6 substances, including the requirement that lead not exceed 0.1% by weight in homogeneous materials. Where designed to be soldered at high temperatures, TI Pb-Free products are suitable for use in specified lead-free processes.

Pb-Free (RoHS Exempt): This component has a RoHS exemption for either 1) lead-based flip-chip solder bumps used between the die and package, or 2) lead-based die adhesive used between the die and leadframe. The component is otherwise considered Pb-Free (RoHS compatible) as defined above.

Green (RoHS & no Sb/Br): TI defines "Green" to mean Pb-Free (RoHS compatible), and free of Bromine (Br) and Antimony (Sb) based flame retardants (Br or Sb do not exceed 0.1% by weight in homogeneous material)

(3) MSL, Peak Temp. - The Moisture Sensitivity Level rating according to the JEDEC industry standard classifications, and peak solder temperature.

(4) There may be additional marking, which relates to the logo, the lot trace code information, or the environmental category on the device.

(5) Multiple Device Markings will be inside parentheses. Only one Device Marking contained in parentheses and separated by a "~" will appear on a device. If a line is indented then it is a continuation of the previous line and the two combined represent the entire Device Marking for that device.

(6) Lead/Ball Finish - Orderable Devices may have multiple material finish options. Finish options are separated by a vertical ruled line. Lead/Ball Finish values may wrap to two lines if the finish value exceeds the maximum column width.

Important Information and Disclaimer: The information provided on this page represents TI's knowledge and belief as of the date that it is provided. TI bases its knowledge and belief on information provided by third parties, and makes no representation or warranty as to the accuracy of such information. Efforts are underway to better integrate information from third parties. TI has taken and continues to take reasonable steps to provide representative and accurate information but may not have conducted destructive testing or chemical analysis on incoming materials and chemicals. TI and TI suppliers consider certain information to be proprietary, and thus CAS numbers and other limited information may not be available for release.

In no event shall TI's liability arising out of such information exceed the total purchase price of the TI part(s) at issue in this document sold by TI to Customer on an annual basis.

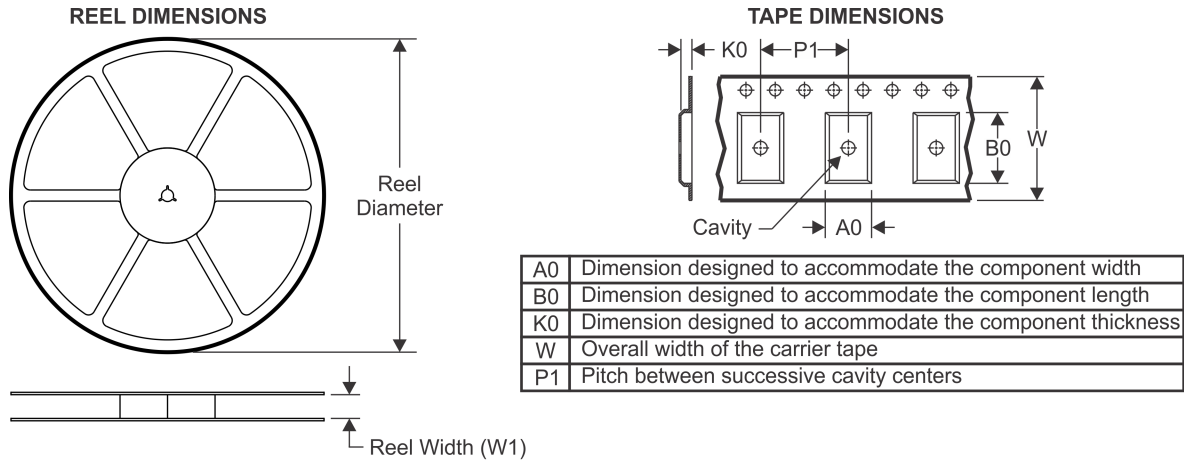
TAPE AND REEL INFORMATION

QUADRANT ASSIGNMENTS FOR PIN 1 ORIENTATION IN TAPE

*All dimensions are nominal

Device	Package Type	Package Drawing	Pins	SPQ	Reel Diameter (mm)	Reel Width W1 (mm)	A0 (mm)	B0 (mm)	K0 (mm)	P1 (mm)	W (mm)	Pin1 Quadrant
TPS23757PWR	TSSOP	PW	20	2000	330.0	16.4	6.95	7.1	1.6	8.0	16.0	Q1

TAPE AND REEL BOX DIMENSIONS



*All dimensions are nominal



Device	Package Type	Package Drawing	Pins	SPQ	Length (mm)	Width (mm)	Height (mm)
TPS23757PWR	TSSOP	PW	20	2000	350.0	350.0	43.0

PW (R-PDSO-G20)

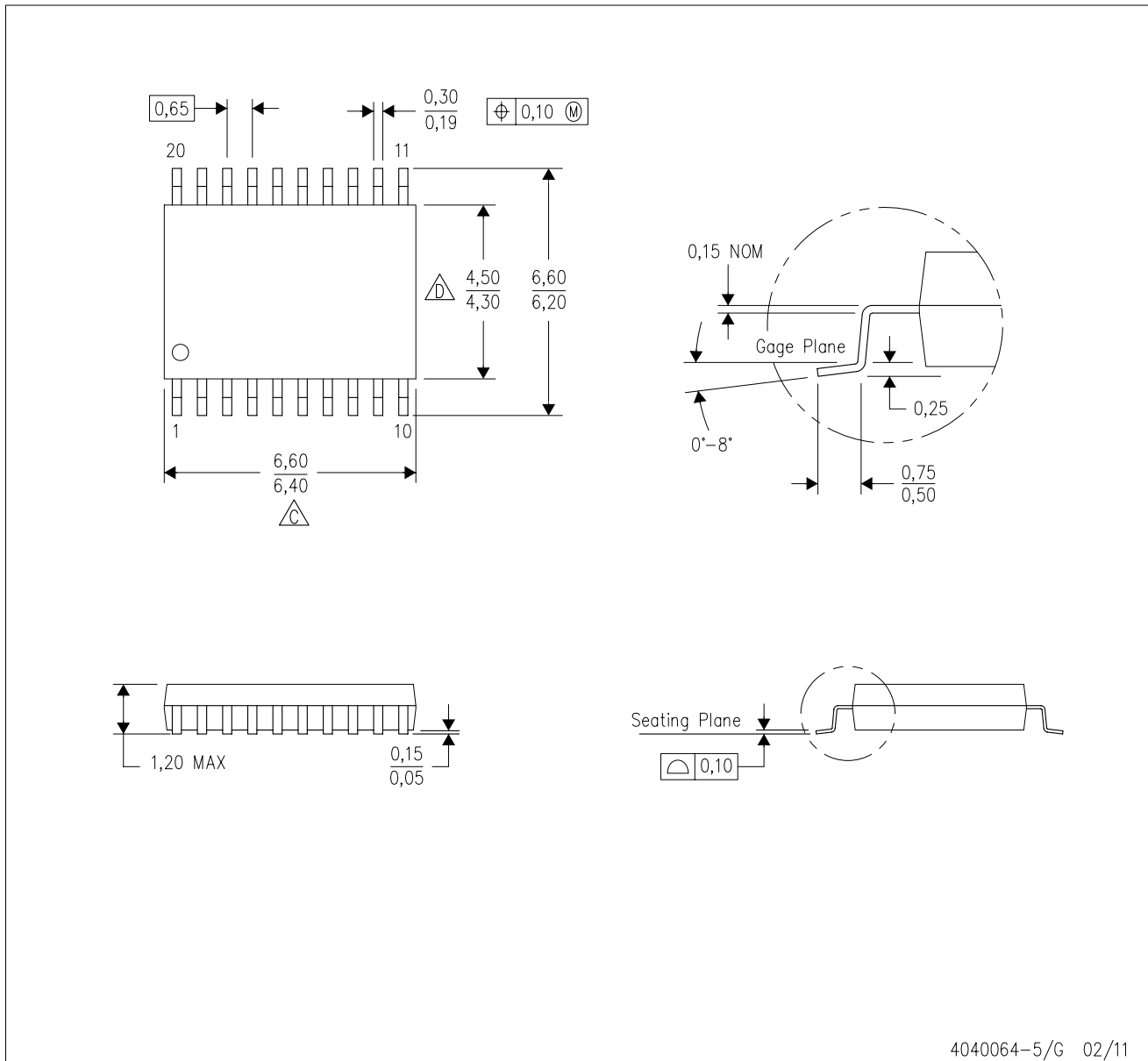
PLASTIC SMALL OUTLINE



4040064-5/G 02/11

- NOTES:
- A. All linear dimensions are in millimeters. Dimensioning and tolerancing per ASME Y14.5M-1994.
 - B. This drawing is subject to change without notice.
 -  C. Body length does not include mold flash, protrusions, or gate burrs. Mold flash, protrusions, or gate burrs shall not exceed 0,15 each side.
 -  D. Body width does not include interlead flash. Interlead flash shall not exceed 0,25 each side.
 - E. Falls within JEDEC MO-153

PW (R-PDSO-G20)

PLASTIC SMALL OUTLINE

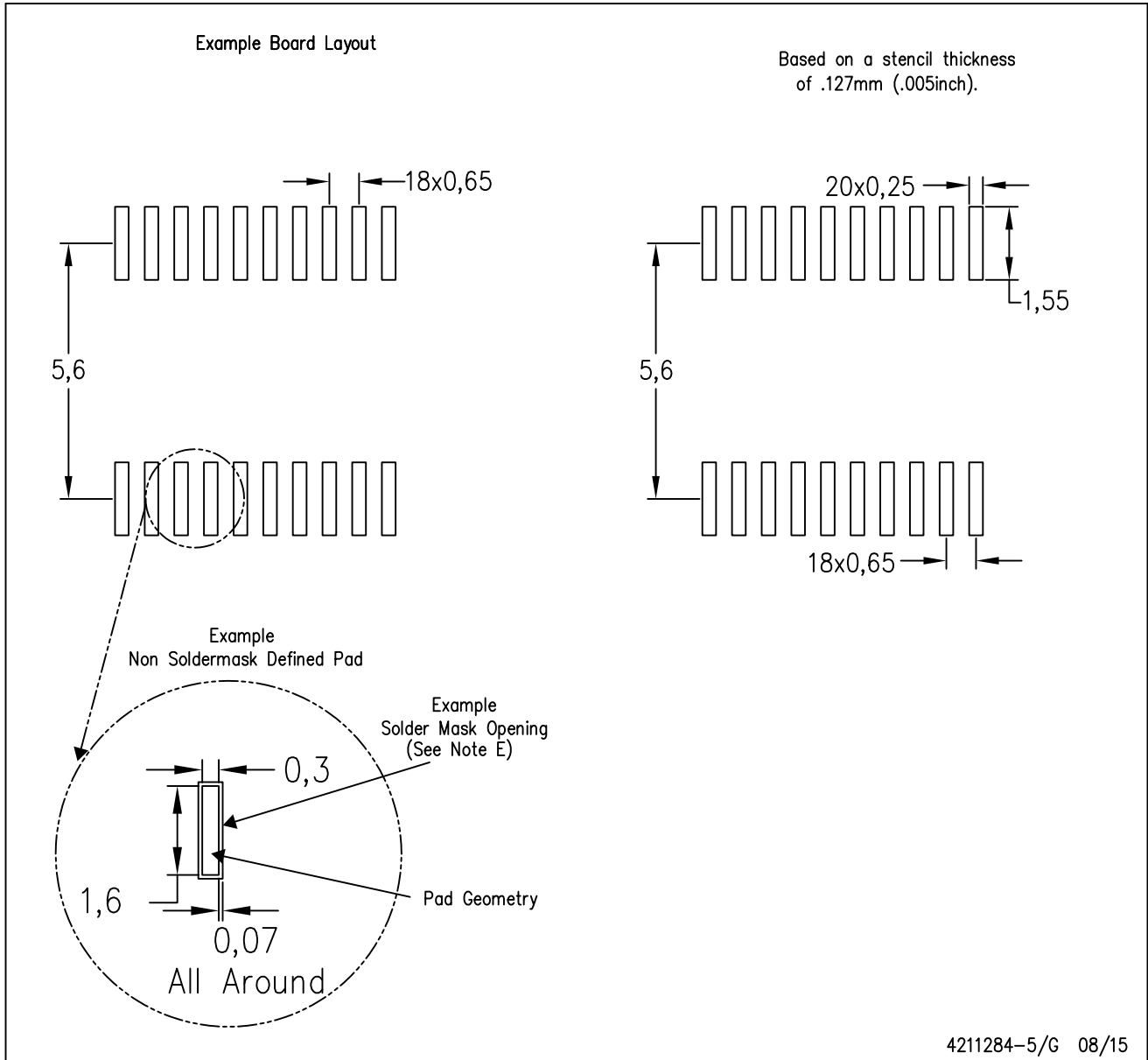

- NOTES:
- A. All linear dimensions are in millimeters.
 - B. This drawing is subject to change without notice.
 - C. Publication IPC-7351 is recommended for alternate design.
 - D. Laser cutting apertures with trapezoidal walls and also rounding corners will offer better paste release. Customers should contact their board assembly site for stencil design recommendations. Refer to IPC-7525 for other stencil recommendations.
 - E. Customers should contact their board fabrication site for solder mask tolerances between and around signal pads.

IMPORTANT NOTICE AND DISCLAIMER

TI PROVIDES TECHNICAL AND RELIABILITY DATA (INCLUDING DATASHEETS), DESIGN RESOURCES (INCLUDING REFERENCE DESIGNS), APPLICATION OR OTHER DESIGN ADVICE, WEB TOOLS, SAFETY INFORMATION, AND OTHER RESOURCES "AS IS" AND WITH ALL FAULTS, AND DISCLAIMS ALL WARRANTIES, EXPRESS AND IMPLIED, INCLUDING WITHOUT LIMITATION ANY IMPLIED WARRANTIES OF MERCHANTABILITY, FITNESS FOR A PARTICULAR PURPOSE OR NON-INFRINGEMENT OF THIRD PARTY INTELLECTUAL PROPERTY RIGHTS.

These resources are intended for skilled developers designing with TI products. You are solely responsible for (1) selecting the appropriate TI products for your application, (2) designing, validating and testing your application, and (3) ensuring your application meets applicable standards, and any other safety, security, or other requirements. These resources are subject to change without notice. TI grants you permission to use these resources only for development of an application that uses the TI products described in the resource. Other reproduction and display of these resources is prohibited. No license is granted to any other TI intellectual property right or to any third party intellectual property right. TI disclaims responsibility for, and you will fully indemnify TI and its representatives against, any claims, damages, costs, losses, and liabilities arising out of your use of these resources.

TI's products are provided subject to TI's Terms of Sale (www.ti.com/legal/termsofsale.html) or other applicable terms available either on ti.com or provided in conjunction with such TI products. TI's provision of these resources does not expand or otherwise alter TI's applicable warranties or warranty disclaimers for TI products.

Mailing Address: Texas Instruments, Post Office Box 655303, Dallas, Texas 75265
Copyright © 2019, Texas Instruments Incorporated

Looking for pricing, stock, or lifecycle information?

Click below to explore more details on WIN SOURCE:

 [View TPS23757PWR](#) on WIN SOURCE

 [Texas Instruments](#) Information

Optimize Your Supply Chain with WIN SOURCE Solutions

-  Global Sourcing Solution
-  Obsolete Management
-  Cost Control Management
-  Shortage Management
-  Alternative Solution
-  Excess Inventory Management