



**THE DATASHEET OF
TPL0401A-10DCKR**



TPL0401x-10 128-TAPS Single-Channel Digital Potentiometer With I²C Interface

1 Features

- Single-Channel, 128-Position Resolution
- 10-k Ω End-to-End Resistance Options
- Low Temperature Coefficient: 22 ppm/ $^{\circ}$ C
- I²C Serial Interface
- 2.7-V to 5.5-V Single-Supply Operation
- \pm 20% Resistance Tolerance
- A and B Versions Have Different I²C Addresses
- L Terminal is Internal and Connected to GND
- Operating Temperature: -40° C to $+125^{\circ}$ C
- Available in Industry Standard SC70 Packages
- ESD Performance Tested per JESD 22
 - 2000-V Human-Body Model (A114-B, Class II)

2 Applications

- Mechanical Potentiometer Replacement
- Adjustable Power Supplies
- Adjustable Gain Amplifiers and Offset Trimming
- Precision Calibration of Setpoint Thresholds
- Sensor Trimming and Calibration

3 Description

The TPL0401x-10 device is a single-channel, linear-taper digital potentiometer with 128 wiper positions. The TPL0401x-10 has the low terminal internal and connected to GND. The position of the wiper can be adjusted using an I²C interface. The TPL0401x-10 is available in a 6-pin SC70 package with a specified temperature range of -40° C to $+125^{\circ}$ C. The part has a 10-k Ω end-to-end resistance and can operate with a supply voltage range of 2.7 V to 5.5 V. This kind of product is widely used in setting the voltage reference for low power DDR3 memory.

The TPL0401x-10 has the low terminal internal and connected to GND.

Device Information⁽¹⁾

PART NUMBER	PACKAGE	BODY SIZE (NOM)
TPL0401A-10 TPL0401B-10	SC70 (6)	2.00 mm x 1.25 mm

(1) For all available packages, see the orderable addendum at the end of the data sheet.

Simplified Schematic

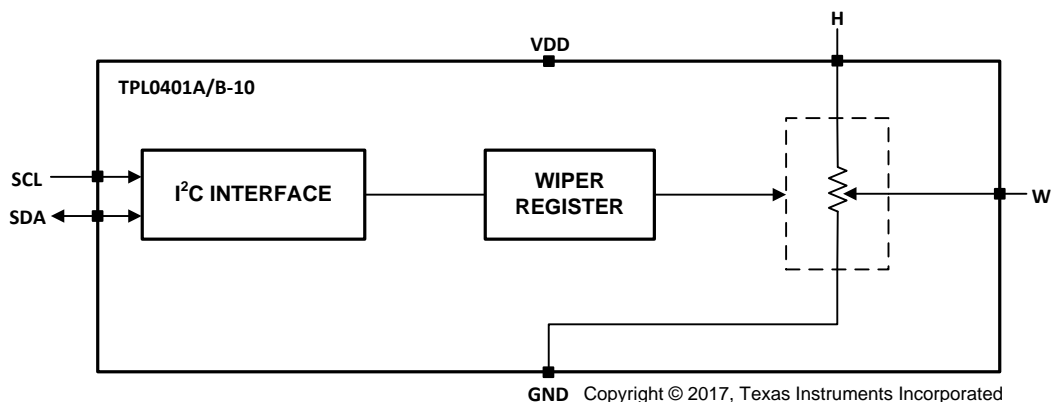

Table of Contents

1 Features	1	10 Application and Implementation	21
2 Applications	1	10.1 Application Information	21
3 Description	1	10.2 Typical Application	21
4 Revision History	2	11 Power Supply Recommendations	23
5 Device Comparison Table	3	11.1 Power Sequence	23
6 Pin Configuration and Functions	3	11.2 Power-On Reset Requirements	23
7 Specifications	4	11.3 I ² C Communication After Power Up	23
7.1 Absolute Maximum Ratings	4	11.4 Wiper Position While Unpowered and After Power Up	24
7.2 ESD Ratings	4	12 Layout	25
7.3 Recommended Operating Conditions	4	12.1 Layout Guidelines	25
7.4 Thermal Information	4	12.2 Layout Example	25
7.5 Electrical Characteristics	5	13 Device and Documentation Support	26
7.6 Timing Requirements	6	13.1 Documentation Support	26
7.7 Typical Characteristics	7	13.2 Related Links	26
8 Parameter Measurement Information	9	13.3 Receiving Notification of Documentation Updates	26
9 Detailed Description	11	13.4 Community Resources	26
9.1 Overview	11	13.5 Trademarks	26
9.2 Functional Block Diagram	11	13.6 Electrostatic Discharge Caution	26
9.3 Feature Description	11	13.7 Glossary	26
9.4 Device Functional Modes	11	14 Mechanical, Packaging, and Orderable Information	26
9.5 Programming	15		
9.6 Register Maps	19		

4 Revision History

Changes from Revision A (March 2012) to Revision B	Page
• Added <i>Device Information</i> table, <i>ESD Ratings</i> table, <i>Feature Description</i> section, <i>Device Functional Modes</i> , <i>Application and Implementation</i> section, <i>Power Supply Recommendations</i> section, <i>Layout</i> section, <i>Device and Documentation Support</i> section, and <i>Mechanical, Packaging, and Orderable Information</i> section	1
• Changed this data sheet to the new SDA format	1
• Removed the obsolete TPL0401C device from the data sheet	1
• Removed TPL0401C references	1
• Changed T _A max value to 125°C from 128°C	4
• Deleted I _{LKG}	5
• Changed R _H typical and max values	5
• Changed I _{DD(STBY)} measurement point from 85°C to 105°C	5
• I _{IN-DIG} min and max values increased	5
• Added Rheostat mode parameters	5
• Corrected typo to t _{OCF} from t _{ICF}	6
• Corrected typo to t _{VD(DATA)} from t _{VD(ACK)}	6
• Updated Typical Characteristics graphs	7
• Updated Resistance Values table	12
• Added power supply recommendations	23

Changes from Original (September 2011) to Revision A	Page
• Added TPL0401C device to the Datasheet	1
• Added TPL0401C Package	1
• Added TPL0401C Functional Block Diagram	1

5 Device Comparison Table

ORDERABLE PART NUMBER	END-TO-END RESISTANCE	I ² C ADDRESS
TPL0401A-10DCKR	10 k Ω	0101110
TPL0401B-10DCKR	10 k Ω	0111110

6 Pin Configuration and Functions

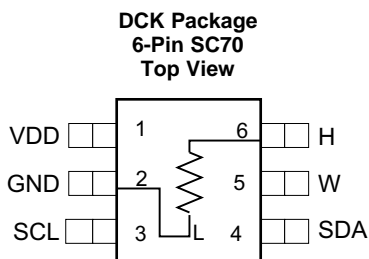

Pin Functions

PIN		TYPE	DESCRIPTION
NO.	NAME		
1	VDD	Power	Positive supply voltage
2	GND	—	Ground
3	SCL	I	I ² C Clock
4	SDA	I/O	I ² C Data
5	W	I/O	Wiper terminal
6	H	I/O	High terminal
—	L	I/O	Low terminal

7 Specifications

7.1 Absolute Maximum Ratings

over operating free-air temperature range (unless otherwise noted) ⁽¹⁾

		MIN	MAX	UNIT	
V _{DD}	Supply voltage	V _{DD} to GND	-0.3	7	V
I _H , I _L , I _W	Continuous current		±5		mA
V _I	Digital input pins (SDA, SCL)		-0.3	V _{DD} + 0.3	V
	Potentiometer pins (H, W)		-0.3	V _{DD} + 0.3	
T _{J(MAX)}	Maximum junction temperature		130		°C
T _{stg}	Storage temperature		-65	150	°C

- (1) Stresses beyond those listed under *Absolute Maximum Ratings* may cause permanent damage to the device. These are stress ratings only, which do not imply functional operation of the device at these or any other conditions beyond those indicated under *Recommended Operating Conditions*. Exposure to absolute-maximum-rated conditions for extended periods may affect device reliability.

7.2 ESD Ratings

		VALUE	UNIT
V _(ESD)	Electrostatic discharge	Human-body model (HBM), per ANSI/ESDA/JEDEC JS-001 ⁽¹⁾	±2500
		Charged-device model (CDM), per JEDEC specification JESD22-C101 ⁽²⁾	±1000

- (1) JEDEC document JEP155 states that 500-V HBM allows safe manufacturing with a standard ESD control process. Manufacturing with less than 500-V HBM is possible with the necessary precautions.
 (2) JEDEC document JEP157 states that 250-V CDM allows safe manufacturing with a standard ESD control process. Manufacturing with less than 250-V CDM is possible with the necessary precautions.

7.3 Recommended Operating Conditions

over operating free-air temperature range (unless otherwise noted)

		MIN	MAX	UNIT	
V _{DD}	Supply voltage		2.7	5.5	V
V _W , V _H , SDA, SCL	Terminal voltage		0	V _{DD}	V
V _{IH}	Voltage input high (SCL, SDA)		0.7 × V _{DD}	V _{DD}	V
V _{IL}	Voltage input low (SCL, SDA)		0	0.3 × V _{DD}	V
I _W	Wiper current		-2	2	mA
T _A	Ambient operating temperature		-40	125	°C

7.4 Thermal Information

THERMAL METRIC ⁽¹⁾	TPL0401x-10		UNIT	
	DCK (SC70)			
	6 PINS			
R _{θJA}	Junction-to-ambient thermal resistance		234	°C/W
R _{θJC(top)}	Junction-to-case (top) thermal resistance		110.5	°C/W
R _{θJB}	Junction-to-board thermal resistance		79	°C/W
ψ _{JT}	Junction-to-top characterization parameter		7.2	°C/W
ψ _{JB}	Junction-to-board characterization parameter		77	°C/W
R _{θJC(bot)}	Junction-to-case (bottom) thermal resistance		N/A	°C/W

- (1) For more information about traditional and new thermal metrics, see the [Semiconductor and IC Package Thermal Metrics](#) application report.

7.5 Electrical Characteristics

Typical values are specified at 25°C and $V_{DD} = 3.3\text{ V}$ (unless otherwise noted)

PARAMETER		TEST CONDITIONS	MIN	TYP	MAX	UNIT
R_{TOTAL}	End-to-end resistance		8	10	12	k Ω
R_H	Terminal resistance			100	200	Ω
R_W	Wiper resistance			35	100	Ω
C_H	Terminal capacitance			10		pF
C_W	Wiper capacitance			11		pF
TC_R	Resistance temperature coefficient			22		ppm/ $^{\circ}\text{C}$
$I_{DD(STBY)}$	V_{DD} standby current	-40°C to +105°C			0.5	μA
		-40°C to +125°C			1.5	
I_{IN-DIG}	Digital pins leakage current (SCL, SDA Inputs)		-2.5		2.5	μA
SERIAL INTERFACE SPECS (SDA, SCL)						
V_{IH}	Input high voltage		$0.7 \times V_{DD}$		V_{DD}	V
V_{IL}	Input low voltage		0	$0.3 \times V_{DD}$		V
V_{OL}	Output low voltage	SDA Pin, $I_{OL} = 4\text{ mA}$		0.4		V
C_{IN}	Pin capacitance	SCL, SDA Inputs		7		pF
VOLTAGE DIVIDER MODE ($V_H = V_{DD}$, $V_W = \text{Not Loaded}$)						
$INL^{(1)(2)}$	Integral non-linearity		-0.5		0.5	LSB
$DNL^{(3)(2)}$	Differential non-linearity		-0.25		0.25	LSB
$ZS_{ERROR}^{(4)(5)}$	Zero-scale error		0	0.75	1.5	LSB
$FS_{ERROR}^{(6)(5)}$	Full-scale error		-1.5	-0.75	0	LSB
T_{CV}	Ratiometric temperature coefficient	Wiper set at mid-scale		4		ppm/ $^{\circ}\text{C}$
BW	Bandwidth	Wiper set at mid-scale, $C_{LOAD} = 10\text{ pF}$		2862		kHz
T_{SW}	Wiper settling time	See Figure 10		0.152		μs
THD+N	Total harmonic distortion	$V_H = 1\text{ V}_{RMS}$ at 1 kHz, measurement at W		0.03		%
RHEOSTAT MODE ($V_H = V_{DD}$, $V_W = \text{Not Loaded}$)						
$RINL^{(7)(8)}$	Rheostat mode integral non-linearity		-1		1	LSB
$RDNL^{(9)(8)}$	Rheostat mode differential non-linearity		0.5		0.5	LSB
$R_{OFFSET}^{(10)(1)}$	Rheostat-mode zero-scale error		0	0.75	2	LSB

(1) $INL = ((V_{MEAS[code\ x]} - V_{MEAS[code\ 0]}) / LSB) - [code\ x]$

(2) $LSB = (V_{MEAS[code\ 127]} - V_{MEAS[code\ 0]}) / 127$

(3) $DNL = ((V_{MEAS[code\ x]} - V_{MEAS[code\ x-1]}) / LSB) - 1$

(4) $ZS_{ERROR} = V_{MEAS[code\ 0]} / IDEAL_LSB$

(5) $IDEAL_LSB = V_H / 128$

(6) $FS_{ERROR} = [(V_{MEAS[code\ 127]} - V_H) / IDEAL_LSB] + 1$

(7) $RINL = ((R_{MEAS[code\ x]} - R_{MEAS[code\ 0]}) / RLSB) - [code\ x]$

(8) $RLSB = (R_{MEAS[code\ 127]} - R_{MEAS[code\ 0]}) / 127$

(9) $RDNL = ((R_{MEAS[code\ x]} - R_{MEAS[code\ x-1]}) / RLSB) - 1$

(10) $R_{OFFSET} = R_{MEAS[code\ 0]} / IDEAL_RLSB$

(11) $IDEAL_RLSB = R_{TOT} / 128$

7.6 Timing Requirements

		MIN	MAX	UNIT
STANDARD MODE				
f_{SCL}	I ² C clock frequency	0	100	kHz
t_{SCH}	I ² C clock high time	4		μs
t_{SCL}	I ² C clock low time	4.7		μs
t_{sp}	I ² C spike time	0	50	ns
t_{SDS}	I ² C serial data setup time	250		ns
t_{SDH}	I ² C serial data hold time	0		ns
t_{ICR}	I ² C input rise time		1000	ns
t_{ICF}	I ² C input fall time		300	ns
t_{OCF}	I ² C output fall time, 10 pF to 400 pF bus		300	ns
t_{BUF}	I ² C bus free time between stop and start	4.7		μs
t_{STS}	I ² C start or repeater start condition setup time	4.7		μs
t_{STH}	I ² C start or repeater start condition hold time	4		μs
t_{SPS}	I ² C stop condition setup time	4		μs
$t_{VD(DATA)}$	Valid data time, SCL low to SDA output valid		1	μs
$t_{VD(ACK)}$	Valid data time of ACK condition, ACK signal from SCL low to SDA (out) low		1	μs
FAST MODE				
f_{SCL}	I ² C clock frequency	0	400	kHz
t_{SCH}	I ² C clock high time	0.6		μs
t_{SCL}	I ² C clock low time	1.3		μs
t_{sp}	I ² C spike time	0	50	ns
t_{SDS}	I ² C serial data setup time	100		ns
t_{SDH}	I ² C serial data hold time	0		ns
t_{ICR}	I ² C input rise time	20	300	ns
t_{ICF}	I ² C input fall time	$20 \times (V_{DD} / 5.5)$	300	ns
t_{OCF}	I ² C output fall time, 10 pF to 400 pF bus	$(V_{DD} / 5.5) \times 20$	300	ns
t_{BUF}	I ² C bus free time between stop and start	1.3		μs
t_{STS}	I ² C start or repeater start condition setup time	1.3		μs
t_{STH}	I ² C start or repeater start condition hold time	0.6		μs
t_{SPS}	I ² C stop condition setup time	0.6		μs
$t_{VD(DATA)}$	Valid data time, SCL low to SDA output valid		1	μs
$t_{VD(ACK)}$	Valid data time of ACK condition, ACK signal from SCL low to SDA (out) low		1	μs

7.7 Typical Characteristics

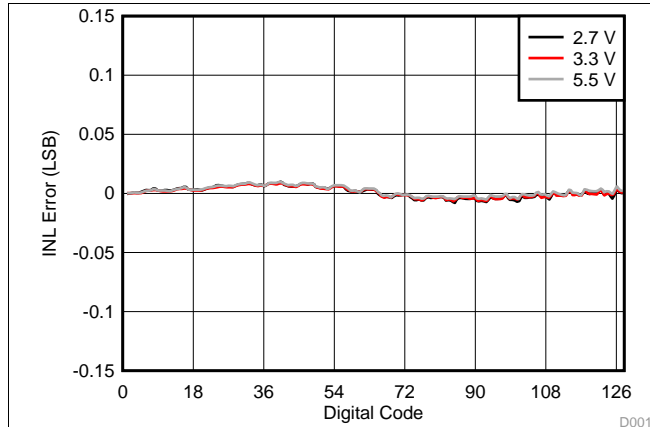

Figure 1. INL vs Tap Position (Potentiometer Mode)

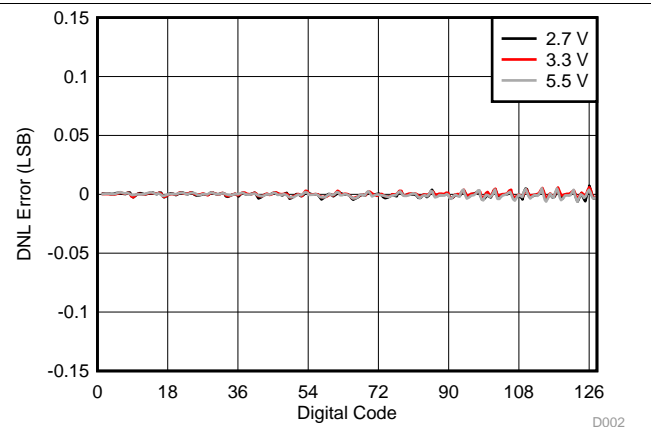

Figure 2. DNL vs Tap Position (Potentiometer Mode)

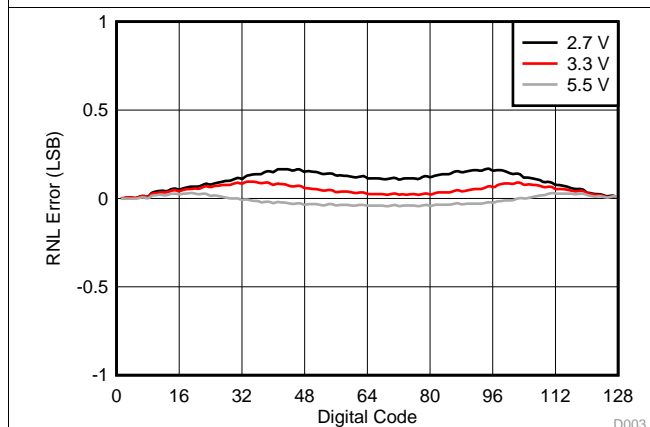

Figure 3. INL vs Tap Position (Rheostat Mode)

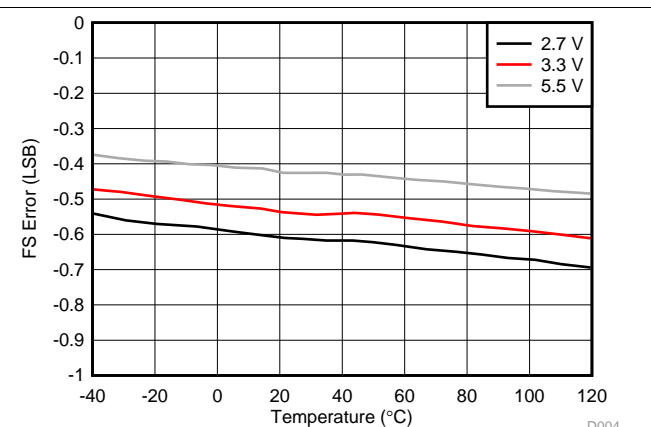

Figure 4. Full Scale Error vs Temperature

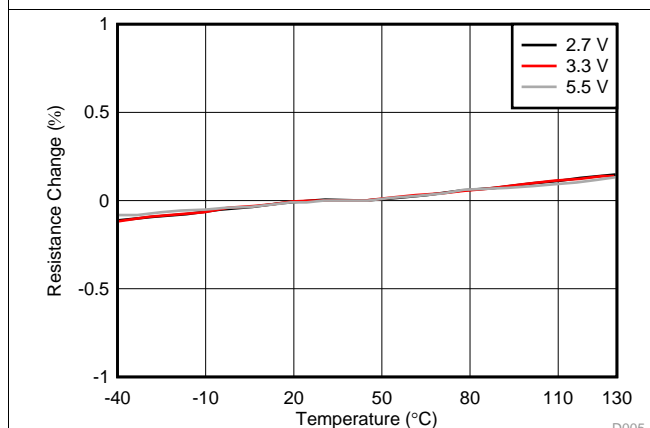

Figure 5. End-to-End R_{TOTAL} Change vs Temperature

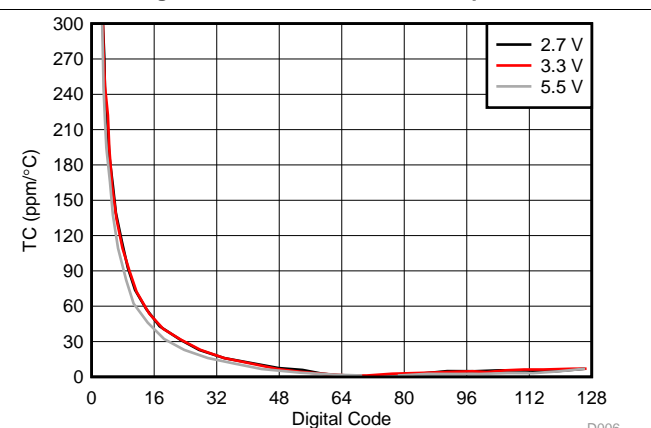
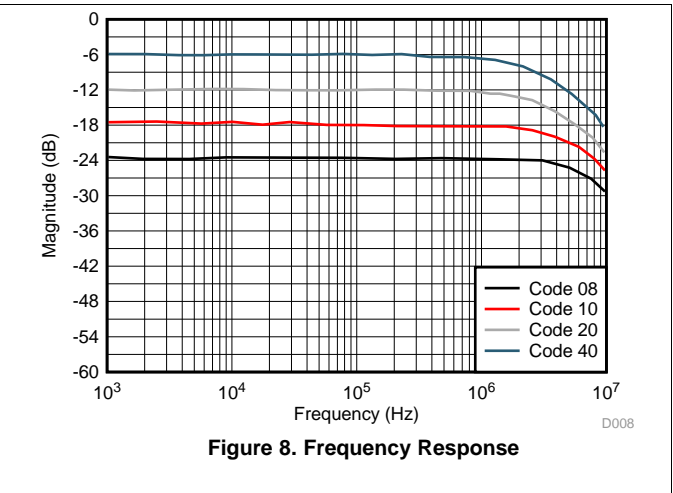
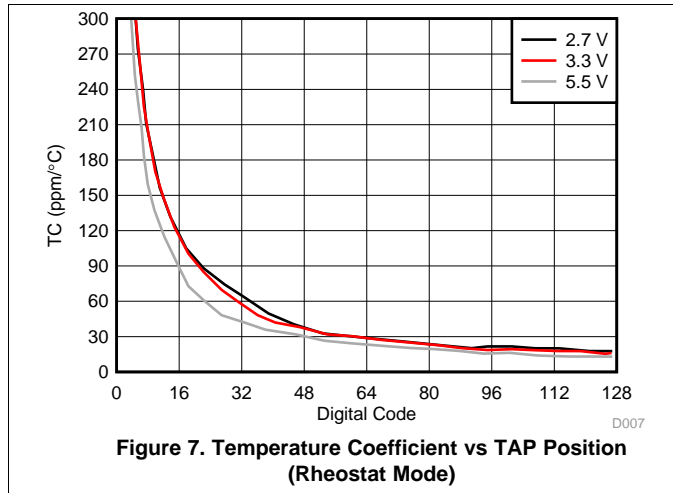
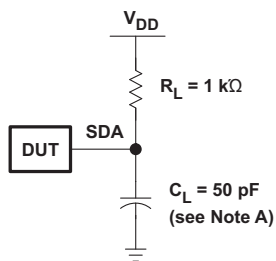

Figure 6. Temperature Coefficient vs TAP Position (Potentiometer Mode)

Typical Characteristics (continued)



8 Parameter Measurement Information



SDA LOAD CONFIGURATION

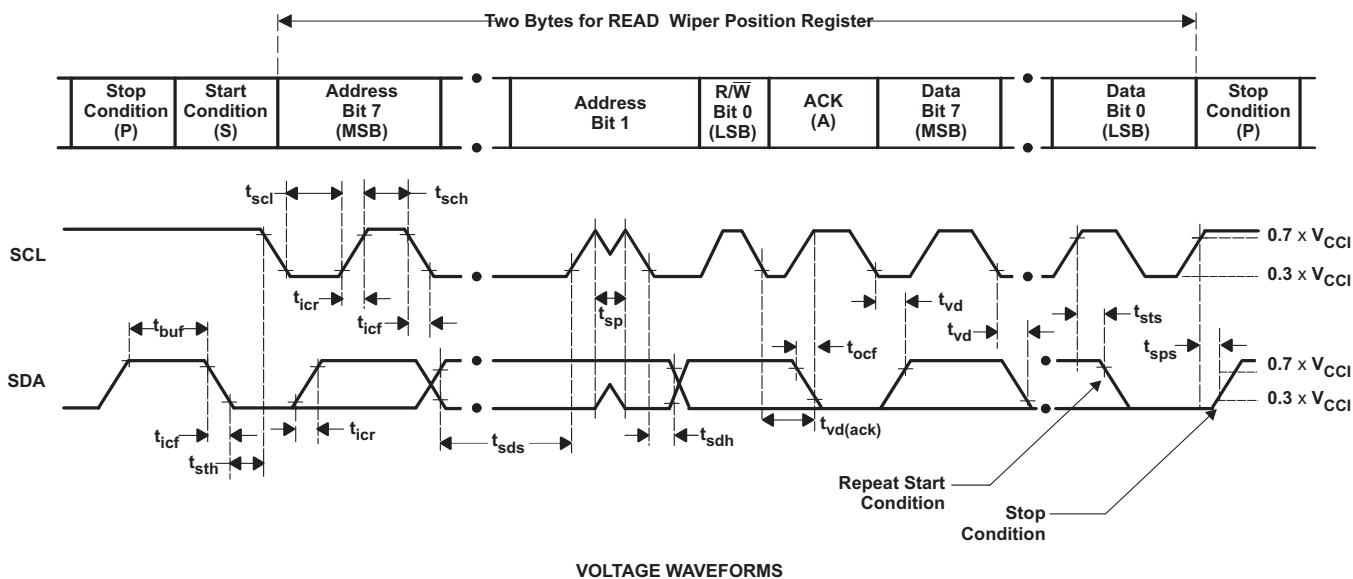

VOLTAGE WAVEFORMS

BYTE	DESCRIPTION
1	I ² C address
2	Wiper Position Data

- A. C_L includes probe and jig capacitance. t_{ocf} is measured with C_L of 10 pF or 400 pF.
- B. All inputs are supplied by generators having the following characteristics: PRR \leq 10 MHz, $Z_0 = 50 \Omega$, $t_r/t_f \leq 30$ ns.
- C. All parameters and waveforms are not applicable to all devices.

Figure 9. I²C Interface Load Circuit and Voltage Waveforms

Parameter Measurement Information (continued)

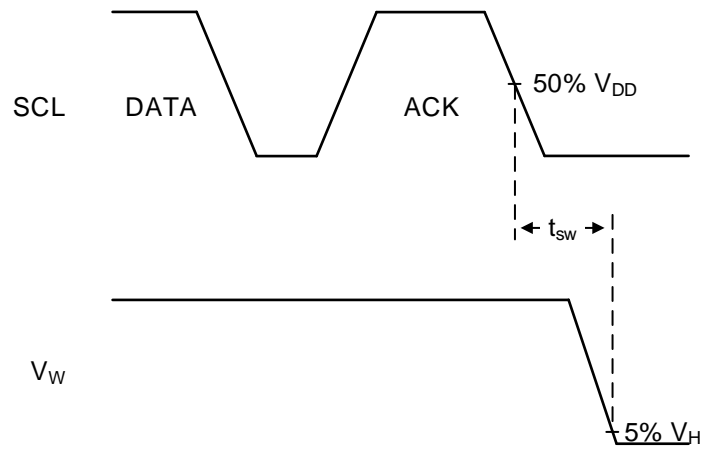

- A. Code change is from 0x40 to 0x00
- B. All inputs are supplied by generators having the following characteristics: PRR ≤ 10 MHz, Z_O = 50 Ω, t_r/t_f ≤ 30 ns.

Figure 10. Switch Time Waveform (t_{sw})

9 Detailed Description

9.1 Overview

The TPL0401x-10 has a single linear-taper digital potentiometer with 128 wiper positions and an end-to-end resistance of 10 k Ω . The potentiometer can be used as a three-terminal potentiometer. The main operation of TPL0401x-10 is in voltage divider mode.

The low (L) terminal of the TPL0401x-10 is tied directly to GND. The high (H) and low (GND) terminals of TPL0401-10 are equivalent to the fixed terminals of a mechanical potentiometer. The H terminal must have a higher voltage than the low terminal (GND). The position of the wiper (W) terminal is controlled by the value in the Wiper Resistance (WR) 8-bit register. When the WR register contains all zeroes (zero-scale), the wiper terminal is closest to its L terminal. As the value of the WR register increases from all zeroes to all ones (full-scale), the wiper moves from the position closest to the GND terminal to the position closest to the H terminal. At the same time, the resistance between W and GND increases, whereas the resistance between W and H decreases.

9.2 Functional Block Diagram

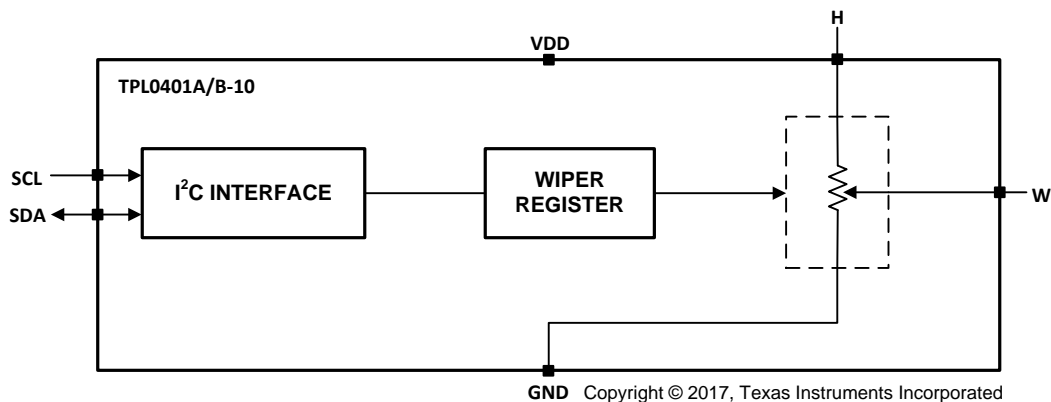

9.3 Feature Description

The TPL0401x-10 device is a single-channel, linear taper digital potentiometer with 128 wiper positions. Default power up state for the TPL0401x-10 is mid code (0x40). The TPL0401x-10 has the low terminal connected to GND internally. The position of the wiper can be adjusted using an I²C interface. The TPL0401x-10 is available in a 6-pin SOT package with a specified temperature range of –40°C to +125°C. The part has a 10-k Ω end-to-end resistance and can operate with a supply voltage range of 2.7 V to 5.5 V. This kind of product is widely used in setting the voltage reference for low power DDR3 memory. The TPL0401x-10 has the low terminal internal and connected to GND.

9.4 Device Functional Modes

9.4.1 Voltage Divider Mode

The digital potentiometer generates a voltage divider when all three terminals are used. The voltage divider at wiper-to-H and wiper-to-GND is proportional to the input voltage at H to L (see [Figure 11](#)).

Device Functional Modes (continued)

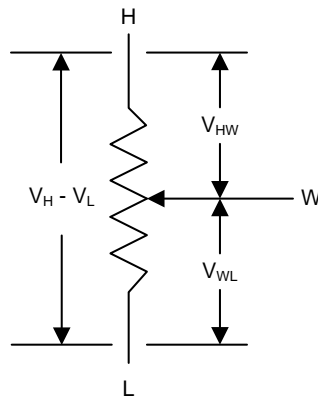

Figure 11. Equivalent Circuit for Voltage Divider Mode

For example, connecting terminal H to 5 V, the output voltage at terminal W can range from 0 V to 5 V. Equation 1 is the general equation defining the output voltage at terminal W for any valid input voltage applied to terminal H and terminal L (GND).

$$V_W = V_{WL} = (V_H - V_L) \times \frac{D}{128} \tag{1}$$

The voltage difference between terminal H and terminal W can also be calculated in Equation 2.

$$V_{HW} = (V_H - V_L) \times \left(1 - \left(\frac{D}{128} \right) \right) \tag{2}$$

where

- D is the decimal value of the wiper code (2)

Table 1 shows the ideal values for DPOT with end-to end resistance of 10 kΩ. The absolute values of resistance can vary significantly but the Ratio (R_{WL}/R_{TOT}) is extremely accurate.

The linearity values are *relative* linearity values (that is, linearity after zero-scale and full-scale offset errors are removed). Consider this when expecting a certain absolute accuracy because some error is introduced when the device gets close in magnitude to the offset errors.

Note that the MSB is always discarded during a write to the wiper position register. For example, if 0x80 is written to the wiper position register, a read returns 0x00. Another similar example is if 0xFF is written, then 0x7F is read.

Table 1. Resistance Values Table

STEP	HEX	R _{WL} (KΩ)	R _{HW} (KΩ)	R _{WL} /R _{TOT}
0	0x00	0.00	10.00	0.0%
1	0x01	0.08	9.92	0.8%
2	0x02	0.16	9.84	1.6%
3	0x03	0.23	9.77	2.3%
4	0x04	0.31	9.69	3.1%
5	0x05	0.39	9.61	3.9%
6	0x06	0.47	9.53	4.7%
7	0x07	0.55	9.45	5.5%
8	0x08	0.63	9.38	6.3%
9	0x09	0.70	9.30	7.0%
10	0x0A	0.78	9.22	7.8%

Table 1. Resistance Values Table (continued)

STEP	HEX	R _{WL} (KΩ)	R _{HW} (KΩ)	R _{WL} /R _{TOT}
11	0x0B	0.86	9.14	8.6%
12	0x0C	0.94	9.06	9.4%
13	0x0D	1.02	8.98	10.2%
14	0x0E	1.09	8.91	10.9%
15	0x0F	1.17	8.83	11.7%
16	0x10	1.25	8.75	12.5%
17	0x11	1.33	8.67	13.3%
18	0x12	1.41	8.59	14.1%
19	0x13	1.48	8.52	14.8%
20	0x14	1.56	8.44	15.6%
21	0x15	1.64	8.36	16.4%
22	0x16	1.72	8.28	17.2%
23	0x17	1.80	8.20	18.0%
24	0x18	1.88	8.13	18.8%
25	0x19	1.95	8.05	19.5%
26	0x1A	2.03	7.97	20.3%
27	0x1B	2.11	7.89	21.1%
28	0x1C	2.19	7.81	21.9%
29	0x1D	2.27	7.73	22.7%
30	0x1E	2.34	7.66	23.4%
31	0x1F	2.42	7.58	24.2%
32	0x20	2.50	7.50	25.0%
33	0x21	2.58	7.42	25.8%
34	0x22	2.66	7.34	26.6%
35	0x23	2.73	7.27	27.3%
36	0x24	2.81	7.19	28.1%
37	0x25	2.89	7.11	28.9%
38	0x26	2.97	7.03	29.7%
39	0x27	3.05	6.95	30.5%
40	0x28	3.13	6.88	31.3%
41	0x29	3.20	6.80	32.0%
42	0x2A	3.28	6.72	32.8%
43	0x2B	3.36	6.64	33.6%
44	0x2C	3.44	6.56	34.4%
45	0x2D	3.52	6.48	35.2%
46	0x2E	3.59	6.41	35.9%
47	0x2F	3.67	6.33	36.7%
48	0x30	3.75	6.25	37.5%
49	0x31	3.83	6.17	38.3%
50	0x32	3.91	6.09	39.1%
51	0x33	3.98	6.02	39.8%
52	0x34	4.06	5.94	40.6%
53	0x35	4.14	5.86	41.4%
54	0x36	4.22	5.78	42.2%
55	0x37	4.30	5.70	43.0%
56	0x38	4.38	5.63	43.8%
57	0x39	4.45	5.55	44.5%

Table 1. Resistance Values Table (continued)

STEP	HEX	R _{WL} (KΩ)	R _{HW} (KΩ)	R _{WL} /R _{TOT}
58	0x3A	4.53	5.47	45.3%
59	0x3B	4.61	5.39	46.1%
60	0x3C	4.69	5.31	46.9%
61	0x3D	4.77	5.23	47.7%
62	0x3E	4.84	5.16	48.4%
63	0x3F	4.92	5.08	49.2%
64 (POR Default)	0x40	5.00	5.00	50.0%
65	0x41	5.08	4.92	50.8%
66	0x42	5.16	4.84	51.6%
67	0x43	5.23	4.77	52.3%
68	0x44	5.31	4.69	53.1%
69	0x45	5.39	4.61	53.9%
70	0x46	5.47	4.53	54.7%
71	0x47	5.55	4.45	55.5%
72	0x48	5.63	4.38	56.3%
73	0x49	5.70	4.30	57.0%
74	0x4A	5.78	4.22	57.8%
75	0x4B	5.86	4.14	58.6%
76	0x4C	5.94	4.06	59.4%
77	0x4D	6.02	3.98	60.2%
78	0x4E	6.09	3.91	60.9%
79	0x4F	6.17	3.83	61.7%
80	0x50	6.25	3.75	62.5%
81	0x51	6.33	3.67	63.3%
82	0x52	6.41	3.59	64.1%
83	0x53	6.48	3.52	64.8%
84	0x54	6.56	3.44	65.6%
85	0x55	6.64	3.36	66.4%
86	0x56	6.72	3.28	67.2%
87	0x57	6.80	3.20	68.0%
88	0x58	6.88	3.13	68.8%
89	0x59	6.95	3.05	69.5%
90	0x5A	7.03	2.97	70.3%
91	0x5B	7.11	2.89	71.1%
92	0x5C	7.19	2.81	71.9%
93	0x5D	7.27	2.73	72.7%
94	0x5E	7.34	2.66	73.4%
95	0x5F	7.42	2.58	74.2%
96	0x60	7.50	2.50	75.0%
97	0x61	7.58	2.42	75.8%
98	0x62	7.66	2.34	76.6%
99	0x63	7.73	2.27	77.3%
100	0x64	7.81	2.19	78.1%
101	0x65	7.89	2.11	78.9%
102	0x66	7.97	2.03	79.7%
103	0x67	8.05	1.95	80.5%
104	0x68	8.13	1.88	81.3%

Table 1. Resistance Values Table (continued)

STEP	HEX	R _{WL} (KΩ)	R _{HW} (KΩ)	R _{WL} /R _{TOT}
105	0x69	8.20	1.80	82.0%
106	0x6A	8.28	1.72	82.8%
107	0x6B	8.36	1.64	83.6%
108	0x6C	8.44	1.56	84.4%
109	0x6D	8.52	1.48	85.2%
110	0x6E	8.59	1.41	85.9%
111	0x6F	8.67	1.33	86.7%
112	0x70	8.75	1.25	87.5%
113	0x71	8.83	1.17	88.3%
114	0x72	8.91	1.09	89.1%
115	0x73	8.98	1.02	89.8%
116	0x74	9.06	0.94	90.6%
117	0x75	9.14	0.86	91.4%
118	0x76	9.22	0.78	92.2%
119	0x77	9.30	0.70	93.0%
120	0x78	9.38	0.63	93.8%
121	0x79	9.45	0.55	94.5%
122	0x7A	9.53	0.47	95.3%
123	0x7B	9.61	0.39	96.1%
124	0x7C	9.69	0.31	96.9%
125	0x7D	9.77	0.23	97.7%
126	0x7E	9.84	0.16	98.4%
127	0x7F	9.92	0.08	99.2%

9.5 Programming

9.5.1 I²C General Operation and Overview

9.5.1.1 START and STOP Conditions

I²C communication with this device is initiated by the master sending a START condition and terminated by the master sending a STOP condition. A high-to-low transition on the SDA line while the SCL is high defines a START condition. A low-to-high transition on the SDA line while the SCL is high defines a STOP condition. See [Figure 12](#).

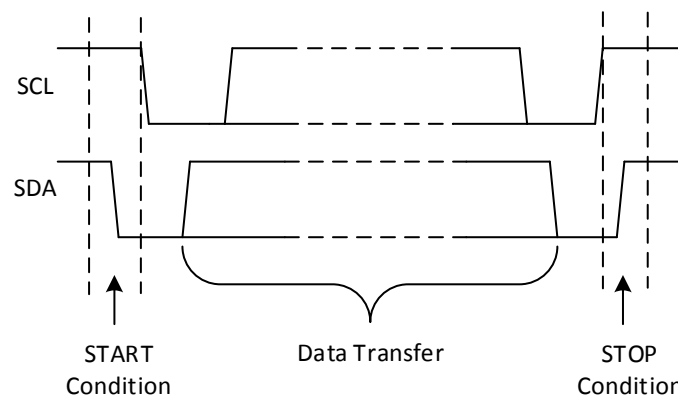

Figure 12. Definition of START and STOP Conditions

Programming (continued)

9.5.1.2 Data Validity and Byte Formation

One data bit is transferred during each clock pulse of the SCL. One byte is comprised of eight bits on the SDA line. See [Figure 13](#). A byte may either be a device address, register address, or data written to or read from a slave.

Data is transferred Most Significant Bit (MSB) first. Any number of data bytes can be transferred from the master to slave between the START and STOP conditions. Data on the SDA line must remain stable during the high phase of the clock period, as changes in the data line when the SCL is high are interpreted as control commands (START or STOP).

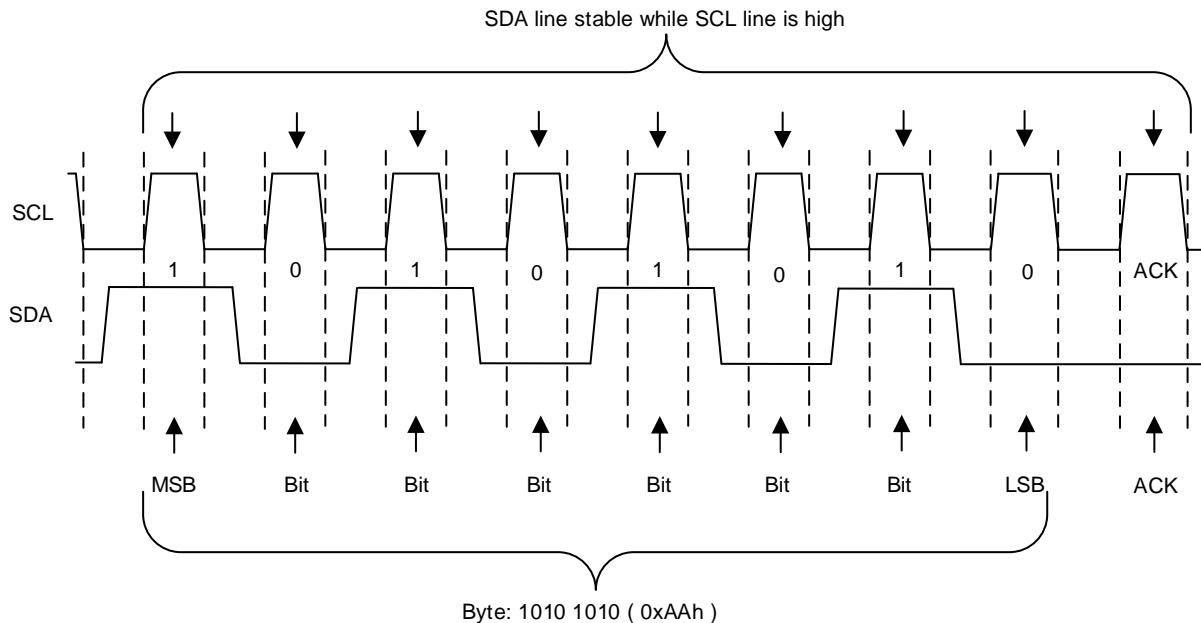

Figure 13. Definition of Byte Formation

9.5.1.3 Acknowledge (ACK) and Not Acknowledge (NACK)

Each byte is followed by one ACK bit from the receiver. The ACK bit allows the receiver to communicate to the transmitter that the byte was successfully received and another byte may be sent.

The transmitter must release the SDA line before the receiver can send the ACK bit. To send an ACK bit, the receiver shall pull down the SDA line during the low phase of the ACK/NACK-related clock period (period 9), so that the SDA line is stable low during the high phase of the ACK/NACK-related clock period. Consider setup and hold times. [Figure 14](#) shows an example use of ACK.

Programming (continued)

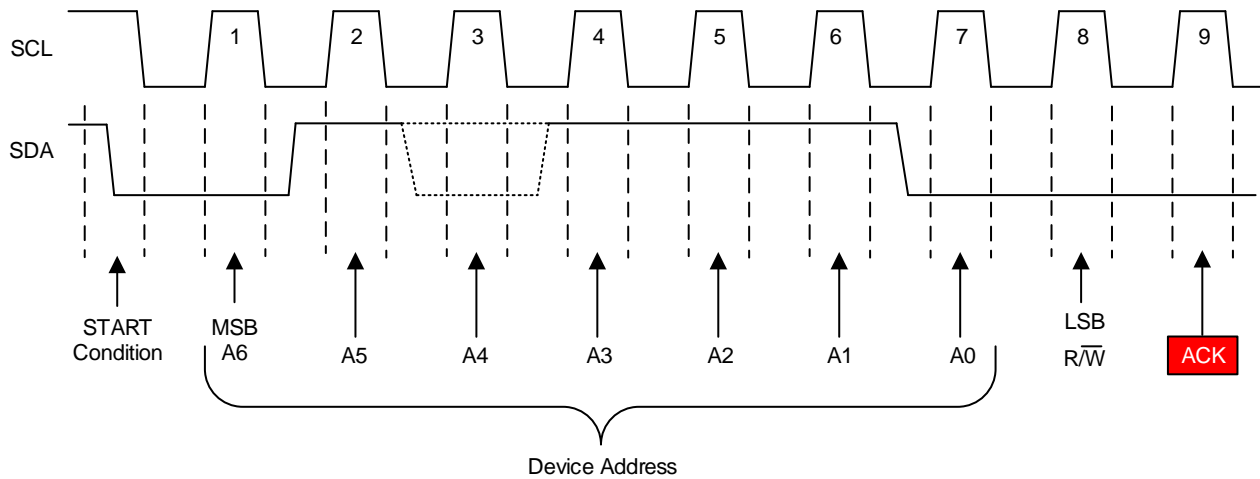

Figure 14. Example Use of ACK

When the SDA line remains high during the ACK/NACK-related clock period, this is a NACK signal. There are several conditions that lead to the generation of a NACK:

- The receiver is unable to receive or transmit because it is performing some real-time function and is not ready to start communication with the master.
- During the transfer, the receiver gets data or commands that it does not understand.
- During the transfer, the receiver cannot receive any more data bytes.
- A master-receiver is done reading data and indicates this to the slave through a NACK.

Figure 15 shows an example use of NACK.

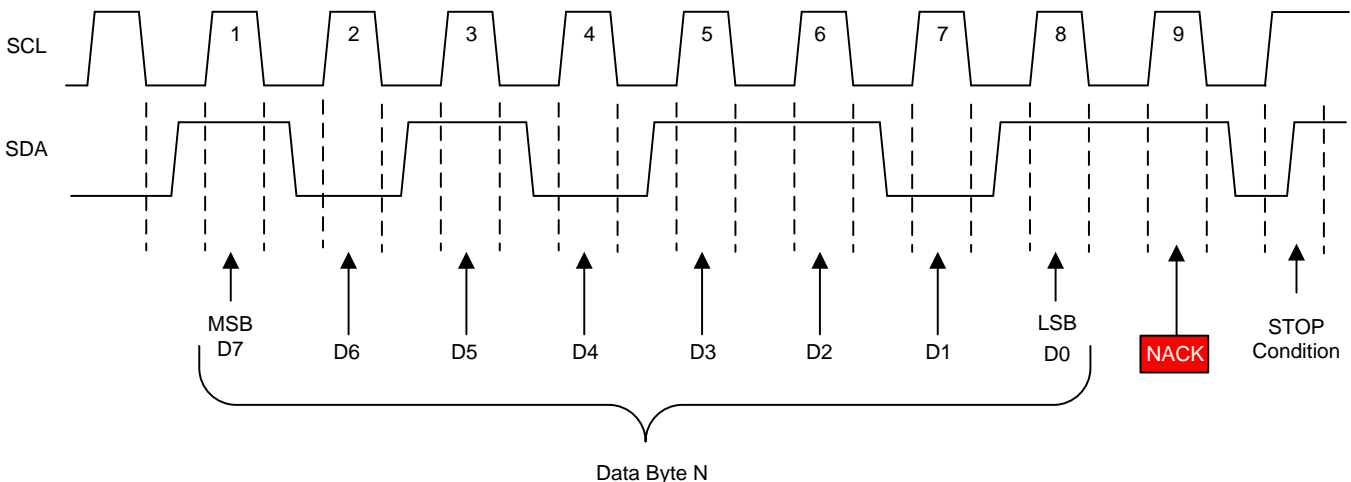

Figure 15. Example Use of NACK

9.5.1.4 Repeated Start

A repeated START condition may be used in place of a complete STOP condition followed by another START condition when performing a read function. The advantage of this is that the I²C bus does not become available after the stop and therefore prevents other devices from grabbing the bus between transfers.

Programming (continued)

9.5.2 Programing with I²C

9.5.2.1 Write Operation

To write on the I²C bus, the master sends a START condition on the bus with the address of the slave, as well as the last bit (the R/W bit) set to 0, which signifies a write. After the slave responds with an acknowledge, the master then sends the register address of the register to which it wishes to write. The slave acknowledges again, letting the master know that it is ready. After this, the master starts sending the register data to the slave until the master has sent all the data necessary (which is sometimes only a single byte), and the master terminates the transmission with a STOP condition. See [Figure 16](#).

- Master controls SDA line
- Slave controls SDA line

Write to one register in a device

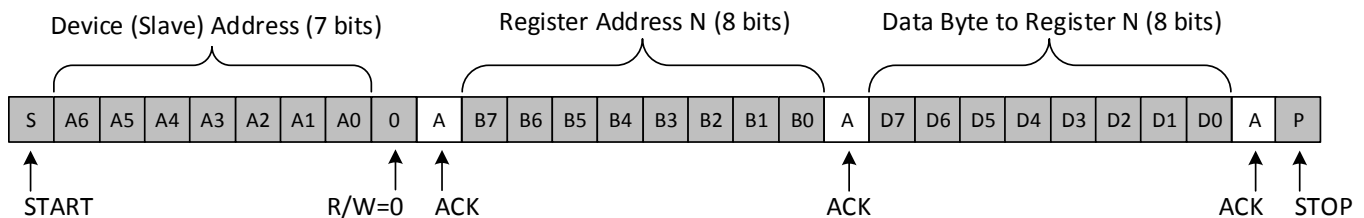

Figure 16. Write Operation

9.5.2.2 Read Operation

Reading from a slave is very similar to writing, but requires some additional steps. In order to read from a slave, the master must first instruct the slave which register it wishes to read from. This is done by the master starting off the transmission in a similar fashion as the write, by sending the address with the R/W bit equal to 0 (signifying a write), followed by the register address it wishes to read from. When the slave acknowledges this register address, the master sends a START condition again, followed by the slave address with the R/W bit set to 1 (signifying a read). This time, the slave acknowledges the read request, and the master releases the SDA bus but continues supplying the clock to the slave. During this part of the transaction, the master becomes the master-receiver, and the slave becomes the slave-transmission.

The master continues to send out the clock pulses, for each byte of data that it wishes to receive. At the end of every byte of data, the master sends an ACK to the slave, letting the slave know that it is ready for more data. When the master has received the number of bytes it was expecting (or needs to stop communication), it sends a NACK, signaling to the slave to halt communications and release the bus. The master follows this up with a STOP condition. [Figure 17](#) shows the read operation from one register.

Programming (continued)

Read from one register in a device

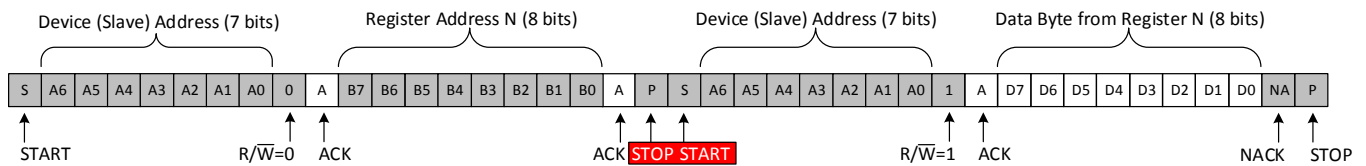

Read from one register in a device (Repeated Start)

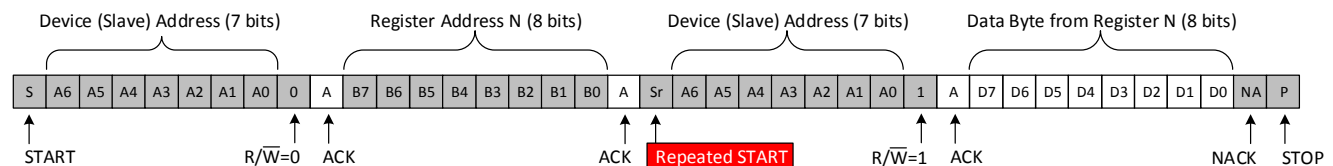

Figure 17. Read Operation from One Register

Read from one register in a device with single register

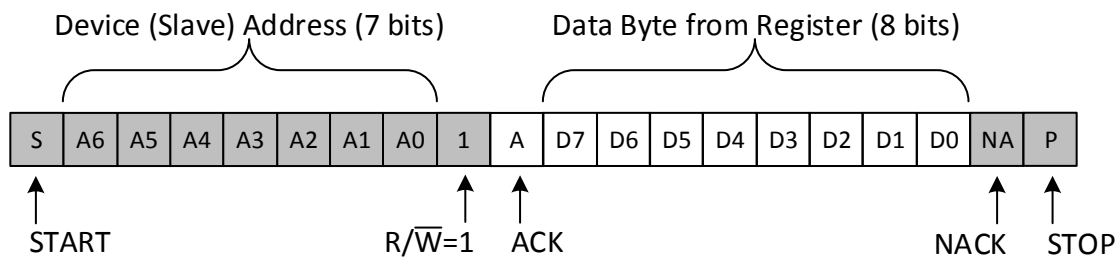

Figure 18. Short Read Operation

The TPL0401x-10 has 1 register, and it is not a requirement that the register address be sent before a read. A shorter read allows the user to simply send a read request to the device address as shown in [Figure 18](#).

9.6 Register Maps

9.6.1 Slave Address

[Table 2](#) and [Table 3](#) show the TPL0401A-10 and TPL0401B-10 bit address respectively.

Table 2. TPL0401A-10 Bit Address

BIT 7 (MSB)	BIT 6	BIT 5	BIT 4	BIT 3	BIT 2	BIT 1	BIT 0 (LSB)
0	1	0	1	1	1	0	R/W

Table 3. TPL0401B-10 Bit Address

BIT 7 (MSB)	BIT 6	BIT 5	BIT 4	BIT 3	BIT 2	BIT 1	BIT 0 (LSB)
0	1	1	1	1	1	0	R/W

9.6.2 Register Address

Following the successful acknowledgment of the address byte, the bus master sends a command byte as shown in [Figure 19](#), which is stored in the Control Register in the TPL0401x-10. The TPL0401x-10 has only 1 register, but requires the command byte be sent during communication.



Figure 19. Register Address Byte

[Table 4](#) shows the TPL0401x-10 register address byte.

Table 4. Register Address Byte

REGISTER ADDRESS BITS								REGISTER ADDRESS (HEX)	REGISTER	PROTOCOL	POWER-UP DEFAULT
B7	B6	B5	B4	B3	B2	B1	B0				
0	0	0	0	0	0	0	0	0x00	Wiper Position	Read/Write byte	0100 0000 (0x40)

See [Table 1](#) for more information on the wiper position register values. Note that the MSB is always discarded during a write to the wiper position register. For example, if 0x80 is written to the wiper position register, a read returns 0x00. Another similar example is if 0xFF is written, then 0x7F is read.

10 Application and Implementation

10.1 Application Information

There are many applications in which voltage division is needed through the use of a digital potentiometer such as the TPL0401x-10; this is one example of the many. In conjunction with many amplifiers, the TPL0401x-10 can effectively be used in voltage divider mode to create a buffer to adjust the reference voltage for DDR3 DIMM1 Memory.

10.2 Typical Application

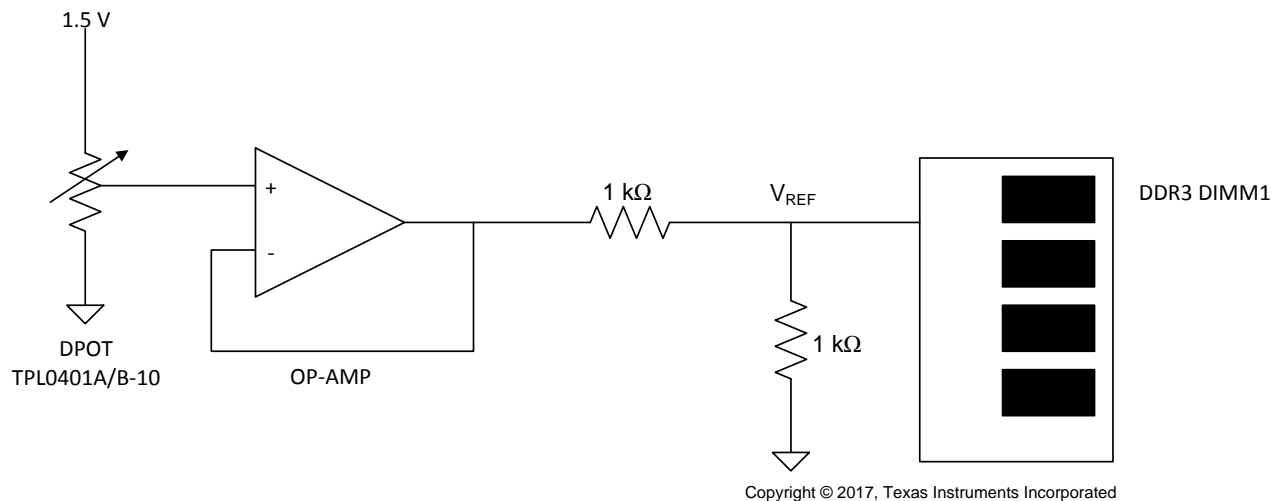

Figure 20. DDR3 Voltage Reference Adjustment

10.2.1 Design Requirements

Table 5 lists the design parameters for this example.

Table 5. Design Parameters

PARAMETER	EXAMPLE VALUE
Input voltage	1.5 V
V_{REF}	0 V to 0.75 V

10.2.2 Detailed Design Procedure

The TPL0401x-10 can be used in voltage divider mode with a unity-gain op amp buffer to provide a clean voltage reference for DDR3 DIMM1 Memory. The analog output voltage, V_{REF1} is determined by the wiper setting programmed through the I²C bus.

The op amp is required to buffer the high-impedance output of the TPL0401x-10 or else loading placed on the output of the voltage divider affects the output voltage.

10.2.3 Application Curve

The voltage, 1.5 V, applied to terminal H of TPL0401x-10 determines the voltage that is buffered by the unity-gain op amp and divided as the DDR3 DIMM1 voltage reference. By using the TPL0401x-10, and dividing the 1.5 V, a maximum of 0.75 V is applied to the buffer and passed to the voltage divider. The output voltage then ranges from 0 V to 0.75 V.

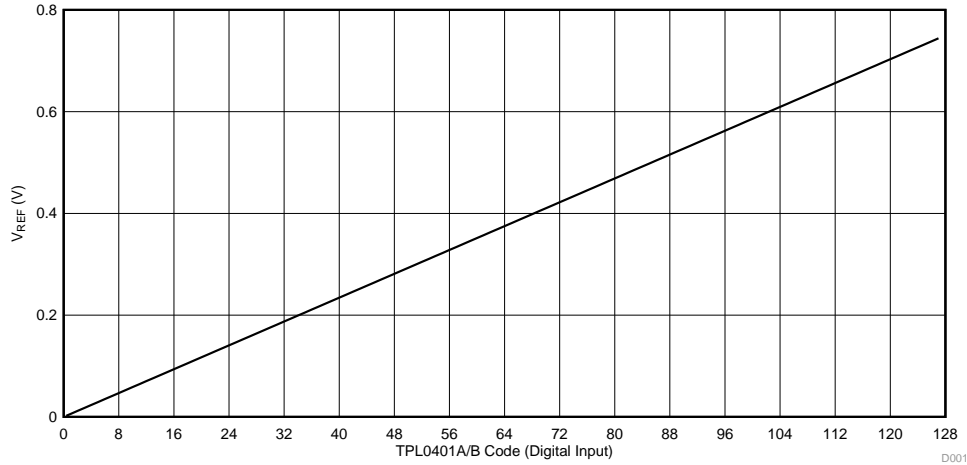

Figure 21. TPL0401-10 Digital Input vs Reference Voltage for DDR3 DIMM Memory

11 Power Supply Recommendations

11.1 Power Sequence

Protection diodes limit the voltage compliance at SDA, SCL, terminal H, and terminal W, making it important to power up V_{DD} first before applying any voltage to SDA, SCL, terminal H, and terminal W. The diodes are forward-biasing, meaning V_{DD} can be powered unintentionally if V_{DD} is not powered first. The ideal power-up sequence is V_{DD} , digital inputs, and V_W and V_H . The order of powering digital inputs, V_H and V_W does not matter as long as they are powered after V_{DD} .

11.2 Power-On Reset Requirements

In the event of a glitch or data corruption, the TPL0401-10 can be reset to its default conditions by using the power-on reset feature. Power-on reset requires that the device go through a power cycle to be completely reset. This reset also happens when the device is powered on for the first time in an application.

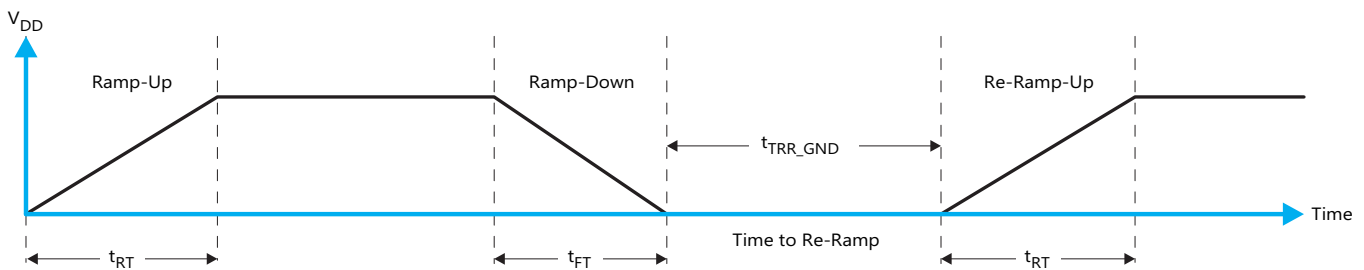

Figure 22. V_{DD} is Lowered to 0 V and then Ramped Up to V_{DD}

Table 6 specifies the performance of the power-on reset feature for the TPL0401-10 for both types of power-on reset.

Table 6. Recommended Supply Sequencing and Ramp Rates at $T_A = 25^\circ\text{C}^{(1)}$

PARAMETER			MIN	MAX	UNIT
t_{FT}	Fall rate	See Figure 22	0.0001	1000	ms
t_{RT}	Rise rate	See Figure 22	0.0001	1000	ms
t_{RR_GND}	Time to re-ramp (when V_{DD} drops to GND)	See Figure 22	1		μs

(1) Not tested. Specified by design.

11.3 I²C Communication After Power Up

In order to ensure a complete device reset after a power up condition, the user must wait 120 μs after power up before initiating communication with the TPL0401x-10. See Figure 23 for an example waveform.

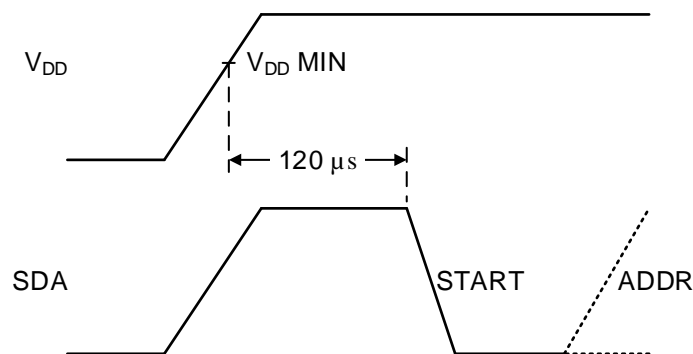

Figure 23. Recommended Start Up Sequence

11.4 Wiper Position While Unpowered and After Power Up

When DPOT is powered off, the impedance of the device is undefined and not known.

Upon power-up, the device returns to 0x40h code because this device does not contain non-volatile memory.

12 Layout

12.1 Layout Guidelines

To ensure reliability of the device, follow common printed-circuit board (PCB) layout guidelines:

- Leads to the input must be as direct as possible with a minimum conductor length.
- The ground path must have low resistance and low inductance.
- Use short trace-lengths to avoid excessive loading.
- It is common to have a dedicated ground plane on an inner layer of the board.
- Terminals that are connected to ground must have a low-impedance path to the ground plane in the form of wide polygon pours and multiple vias.
- Use bypass capacitors on power supplies and placed them as close as possible to the V_{DD} pin.
- Apply low equivalent series resistance (0.1- μ F to 10- μ F tantalum or electrolytic capacitors) at the supplies to minimize transient disturbances and to filter low-frequency ripple.
- To reduce the total I²C bus capacitance added by PCB parasitics, data lines (SCL and SDA) must be as short as possible and the widths of the traces must also be minimized (for example, 5 to 10 mils depending on copper weight).

12.2 Layout Example

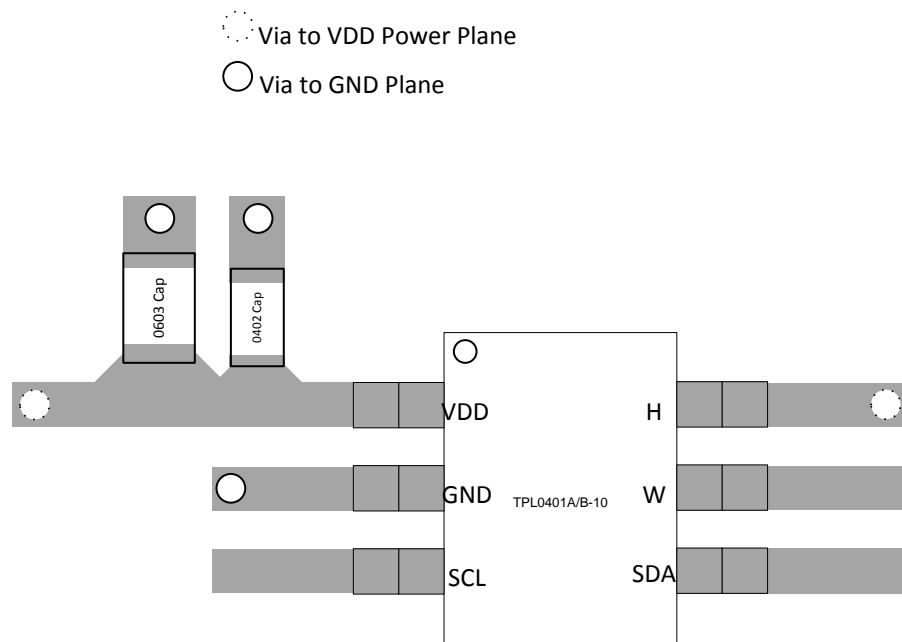

Figure 24. Layout Recommendation

13 Device and Documentation Support

13.1 Documentation Support

13.1.1 Related Documentation

For related documentation, see the following:

- [*PC Bus Pullup Resistor Calculation*](#)
- [*Understanding the PC Bus*](#)
- [*TPL0401 Evaluation Module User's Guide*](#)

13.2 Related Links

The table below lists quick access links. Categories include technical documents, support and community resources, tools and software, and quick access to order now.

Table 7. Related Links

PARTS	PRODUCT FOLDER	ORDER NOW	TECHNICAL DOCUMENTS	TOOLS & SOFTWARE	SUPPORT & COMMUNITY
TPL0401A	Click here	Click here	Click here	Click here	Click here
TPL0401B	Click here	Click here	Click here	Click here	Click here

13.3 Receiving Notification of Documentation Updates

To receive notification of documentation updates, navigate to the device product folder on ti.com. In the upper right corner, click on *Alert me* to register and receive a weekly digest of any product information that has changed. For change details, review the revision history included in any revised document.

13.4 Community Resources

The following links connect to TI community resources. Linked contents are provided "AS IS" by the respective contributors. They do not constitute TI specifications and do not necessarily reflect TI's views; see TI's [Terms of Use](#).

TI E2E™ Online Community *TI's Engineer-to-Engineer (E2E) Community*. Created to foster collaboration among engineers. At e2e.ti.com, you can ask questions, share knowledge, explore ideas and help solve problems with fellow engineers.

Design Support *TI's Design Support* Quickly find helpful E2E forums along with design support tools and contact information for technical support.

13.5 Trademarks

E2E is a trademark of Texas Instruments.
 All other trademarks are the property of their respective owners.

13.6 Electrostatic Discharge Caution



These devices have limited built-in ESD protection. The leads should be shorted together or the device placed in conductive foam during storage or handling to prevent electrostatic damage to the MOS gates.

13.7 Glossary

[SLYZ022](#) — *TI Glossary*.

This glossary lists and explains terms, acronyms, and definitions.

14 Mechanical, Packaging, and Orderable Information

The following pages include mechanical, packaging, and orderable information. This information is the most current data available for the designated devices. This data is subject to change without notice and revision of this document. For browser-based versions of this data sheet, refer to the left-hand navigation.

PACKAGING INFORMATION

Orderable Device	Status (1)	Package Type	Package Drawing	Pins	Package Qty	Eco Plan (2)	Lead finish/ Ball material (6)	MSL Peak Temp (3)	Op Temp (°C)	Device Marking (4/5)	Samples
TPL0401A-10DCKR	ACTIVE	SC70	DCK	6	3000	RoHS & Green	NIPDAU	Level-1-260C-UNLIM	-40 to 125	(7TD, 7TV)	Samples
TPL0401B-10DCKR	ACTIVE	SC70	DCK	6	3000	RoHS & Green	NIPDAU	Level-1-260C-UNLIM	-40 to 125	(7UD, 7UV)	Samples

(1) The marketing status values are defined as follows:

ACTIVE: Product device recommended for new designs.

LIFEBUY: TI has announced that the device will be discontinued, and a lifetime-buy period is in effect.

NRND: Not recommended for new designs. Device is in production to support existing customers, but TI does not recommend using this part in a new design.

PREVIEW: Device has been announced but is not in production. Samples may or may not be available.

OBSELETE: TI has discontinued the production of the device.

(2) **RoHS:** TI defines "RoHS" to mean semiconductor products that are compliant with the current EU RoHS requirements for all 10 RoHS substances, including the requirement that RoHS substance do not exceed 0.1% by weight in homogeneous materials. Where designed to be soldered at high temperatures, "RoHS" products are suitable for use in specified lead-free processes. TI may reference these types of products as "Pb-Free".

RoHS Exempt: TI defines "RoHS Exempt" to mean products that contain lead but are compliant with EU RoHS pursuant to a specific EU RoHS exemption.

Green: TI defines "Green" to mean the content of Chlorine (Cl) and Bromine (Br) based flame retardants meet JS709B low halogen requirements of <=1000ppm threshold. Antimony trioxide based flame retardants must also meet the <=1000ppm threshold requirement.

(3) MSL, Peak Temp. - The Moisture Sensitivity Level rating according to the JEDEC industry standard classifications, and peak solder temperature.

(4) There may be additional marking, which relates to the logo, the lot trace code information, or the environmental category on the device.

(5) Multiple Device Markings will be inside parentheses. Only one Device Marking contained in parentheses and separated by a "~" will appear on a device. If a line is indented then it is a continuation of the previous line and the two combined represent the entire Device Marking for that device.

(6) Lead finish/Ball material - Orderable Devices may have multiple material finish options. Finish options are separated by a vertical ruled line. Lead finish/Ball material values may wrap to two lines if the finish value exceeds the maximum column width.

Important Information and Disclaimer:The information provided on this page represents TI's knowledge and belief as of the date that it is provided. TI bases its knowledge and belief on information provided by third parties, and makes no representation or warranty as to the accuracy of such information. Efforts are underway to better integrate information from third parties. TI has taken and continues to take reasonable steps to provide representative and accurate information but may not have conducted destructive testing or chemical analysis on incoming materials and chemicals. TI and TI suppliers consider certain information to be proprietary, and thus CAS numbers and other limited information may not be available for release.

In no event shall TI's liability arising out of such information exceed the total purchase price of the TI part(s) at issue in this document sold by TI to Customer on an annual basis.

OTHER QUALIFIED VERSIONS OF TPL0401A-10, TPL0401B-10 :

- Automotive: [TPL0401A-10-Q1](#), [TPL0401B-10-Q1](#)

NOTE: Qualified Version Definitions:

- Automotive - Q100 devices qualified for high-reliability automotive applications targeting zero defects

TAPE AND REEL INFORMATION

QUADRANT ASSIGNMENTS FOR PIN 1 ORIENTATION IN TAPE

*All dimensions are nominal

Device	Package Type	Package Drawing	Pins	SPQ	Reel Diameter (mm)	Reel Width W1 (mm)	A0 (mm)	B0 (mm)	K0 (mm)	P1 (mm)	W (mm)	Pin1 Quadrant
TPL0401A-10DCKR	SC70	DCK	6	3000	180.0	8.4	2.41	2.41	1.2	4.0	8.0	Q3
TPL0401B-10DCKR	SC70	DCK	6	3000	180.0	8.4	2.41	2.41	1.2	4.0	8.0	Q3

TAPE AND REEL BOX DIMENSIONS

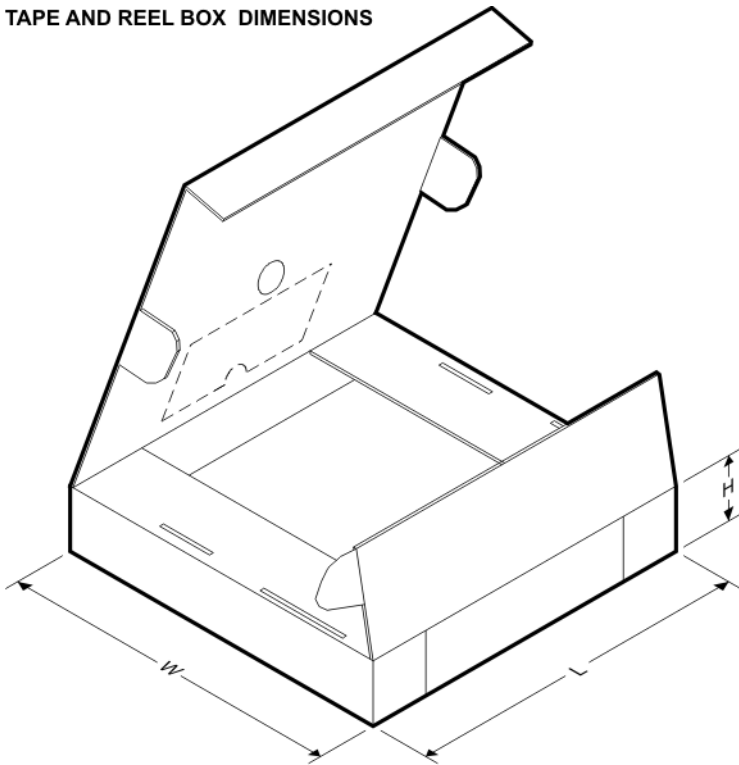

*All dimensions are nominal

Device	Package Type	Package Drawing	Pins	SPQ	Length (mm)	Width (mm)	Height (mm)
TPL0401A-10DCKR	SC70	DCK	6	3000	202.0	201.0	28.0
TPL0401B-10DCKR	SC70	DCK	6	3000	202.0	201.0	28.0

DCK0006A



PACKAGE OUTLINE

SOT - 1.1 max height

SMALL OUTLINE TRANSISTOR

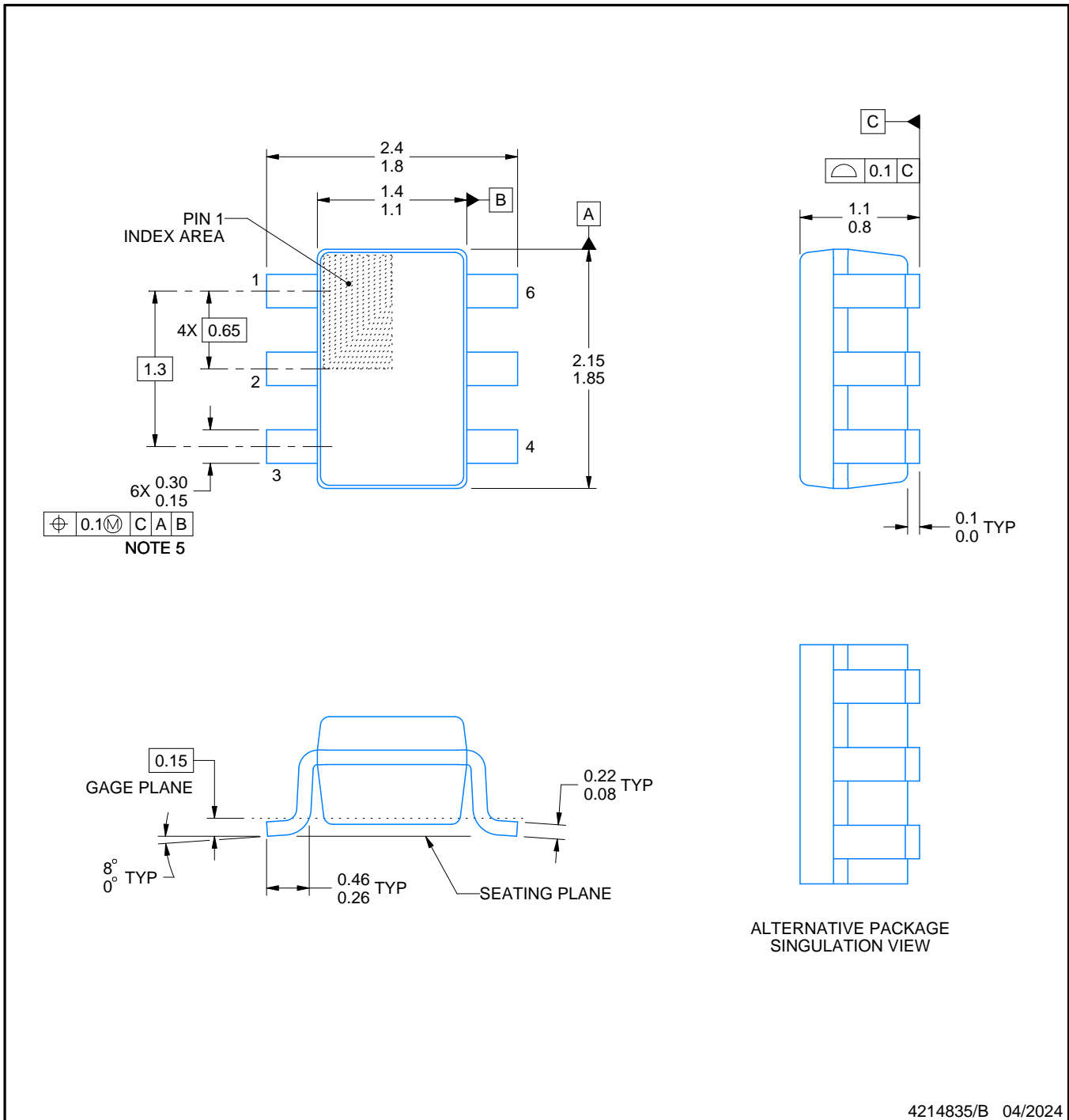

NOTES:

1. All linear dimensions are in millimeters. Any dimensions in parenthesis are for reference only. Dimensioning and tolerancing per ASME Y14.5M.
2. This drawing is subject to change without notice.
3. Body dimensions do not include mold flash or protrusion. Mold flash and protrusion shall not exceed 0.15 per side.
4. Falls within JEDEC MO-203 variation AB.

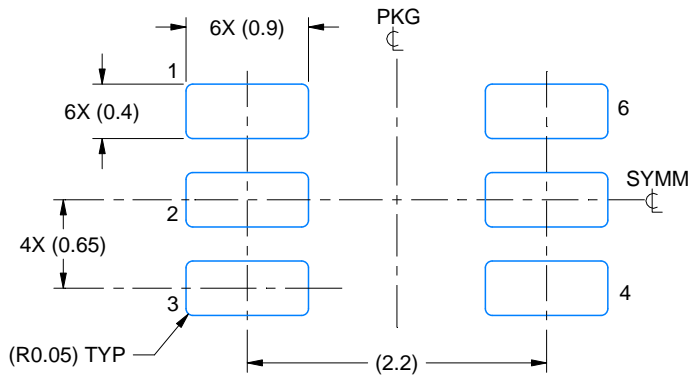

LAND PATTERN EXAMPLE
EXPOSED METAL SHOWN
SCALE:18X

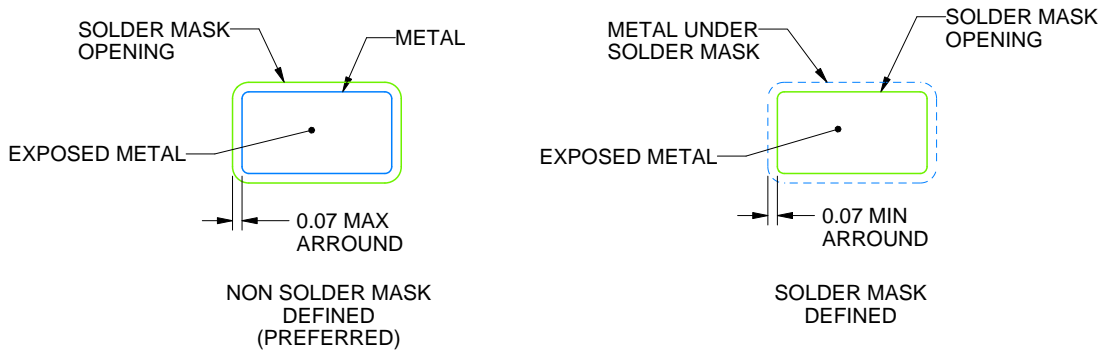

SOLDER MASK DETAILS

4214835/B 04/2024

NOTES: (continued)

- 5. Publication IPC-7351 may have alternate designs.
- 6. Solder mask tolerances between and around signal pads can vary based on board fabrication site.

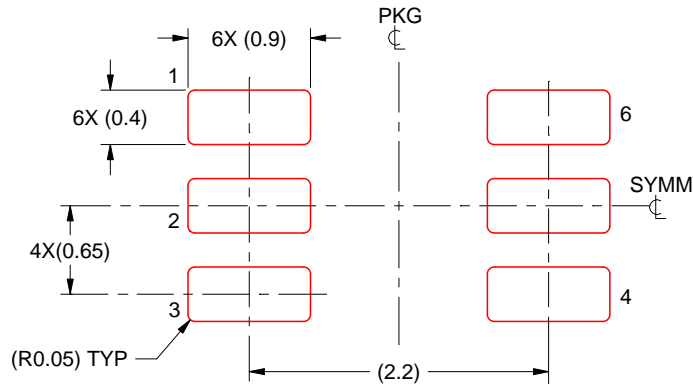

SOLDER PASTE EXAMPLE
BASED ON 0.125 THICK STENCIL
SCALE:18X

4214835/B 04/2024

NOTES: (continued)

7. Laser cutting apertures with trapezoidal walls and rounded corners may offer better paste release. IPC-7525 may have alternate design recommendations.
8. Board assembly site may have different recommendations for stencil design.

IMPORTANT NOTICE AND DISCLAIMER

TI PROVIDES TECHNICAL AND RELIABILITY DATA (INCLUDING DATA SHEETS), DESIGN RESOURCES (INCLUDING REFERENCE DESIGNS), APPLICATION OR OTHER DESIGN ADVICE, WEB TOOLS, SAFETY INFORMATION, AND OTHER RESOURCES "AS IS" AND WITH ALL FAULTS, AND DISCLAIMS ALL WARRANTIES, EXPRESS AND IMPLIED, INCLUDING WITHOUT LIMITATION ANY IMPLIED WARRANTIES OF MERCHANTABILITY, FITNESS FOR A PARTICULAR PURPOSE OR NON-INFRINGEMENT OF THIRD PARTY INTELLECTUAL PROPERTY RIGHTS.

These resources are intended for skilled developers designing with TI products. You are solely responsible for (1) selecting the appropriate TI products for your application, (2) designing, validating and testing your application, and (3) ensuring your application meets applicable standards, and any other safety, security, regulatory or other requirements.

These resources are subject to change without notice. TI grants you permission to use these resources only for development of an application that uses the TI products described in the resource. Other reproduction and display of these resources is prohibited. No license is granted to any other TI intellectual property right or to any third party intellectual property right. TI disclaims responsibility for, and you will fully indemnify TI and its representatives against, any claims, damages, costs, losses, and liabilities arising out of your use of these resources.

TI's products are provided subject to [TI's Terms of Sale](#) or other applicable terms available either on [ti.com](https://www.ti.com) or provided in conjunction with such TI products. TI's provision of these resources does not expand or otherwise alter TI's applicable warranties or warranty disclaimers for TI products.

TI objects to and rejects any additional or different terms you may have proposed.

Mailing Address: Texas Instruments, Post Office Box 655303, Dallas, Texas 75265
Copyright © 2024, Texas Instruments Incorporated

Looking for pricing, stock, or lifecycle information?

Click below to explore more details on WIN SOURCE:

 [View TPL0401A-10DCKR on WIN SOURCE](#)

 [Texas Instruments](#) Information

Optimize Your Supply Chain with WIN SOURCE Solutions

-  Global Sourcing Solution
-  Obsolete Management
-  Cost Control Management
-  Shortage Management
-  Alternative Solution
-  Excess Inventory Management