



**THE DATASHEET OF
TPD4S214YFFR**



TPD4S214 USB OTG Companion Device with V_{BUS} Over Voltage Protection, Over Current Protection, and Four Channel ESD Protection

1 Features

- Input Voltage Protection at V_{BUS} from -7 V to 30 V
- IEC61000-4-2 Level 4 ESD Protection
 - $\pm 15\text{-kV}$ Contact Discharge
 - $\pm 15\text{-kV}$ Air Gap Discharge
- IEC 61000-4-5 Surge Protection
 - 7.8 A ($8/20\ \mu\text{s}$)
- Low $R_{DS(ON)}$ N-CH FET Switch for High Efficiency
- Compliant with USB2.0 and USB3.0 OTG spec
- User Adjustable Current Limit From 250 mA to Beyond 1.2 A
- Built-in Soft-start
- Reverse Current Blocking
- Over Voltage Lock Out for V_{BUS}
- Under Voltage Lock Out for V_{OTG_IN}
- Thermal Shutdown and Short Circuit Protection
- Auto Retry on any Fault; No Latching Off States
- Integrated V_{BUS} Detection Circuit
- Low Capacitance TVS ESD Clamp for USB2.0 High Speed Data Rate
- Internal 16ms Startup Delay
- Space Saving WCSP (12-YFF) Package
- UL Listed and CB File No. E169910

2 Applications

- Cell Phones
- Tablet, eBook
- Portable Media Players
- Digital Camera

4 Simplified Schematic

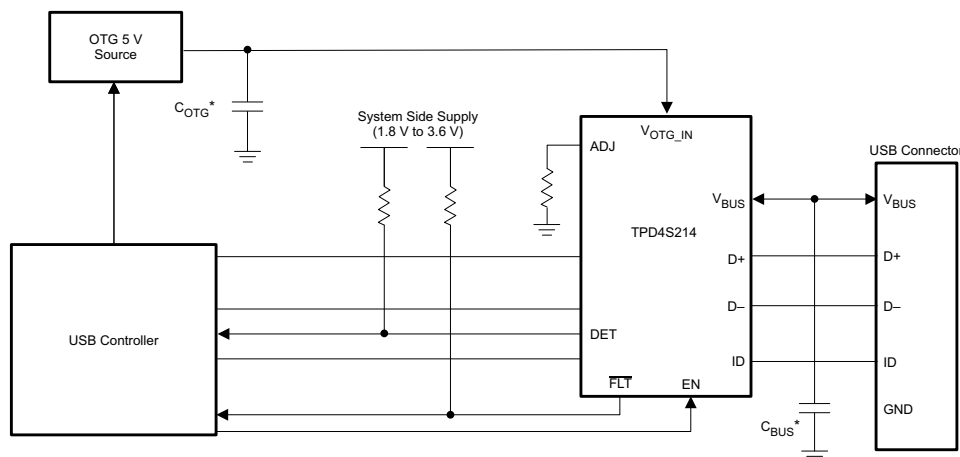

3 Description

The TPD4S214 is a single-chip protection solution for USB On-the-Go (OTG) and other current limited USB applications. This device includes an integrated low $R_{DS(ON)}$ N-channel current limited switch for the OTG current supply to peripheral devices. TPD4S214 offers low capacitance transient voltage suppression (TVS) electrostatic discharge (ESD) clamping diodes for the D+, D-, and ID pins for both USB2.0 and USB3.0 applications. The V_{BUS} pin can handle continuous voltage ranging from -7 V to 30 V . The over voltage lock-out (OVLO) at the V_{BUS} pin ensures that if there is a fault condition at the V_{BUS} line, TPD4S214 is able to isolate it and protect the internal circuitry from damage. Similarly, the under voltage lock out (UVLO) at the V_{OTG_IN} pin ensures that there is no power drain from the internal OTG supply to external V_{BUS} if V_{OTG_IN} droops below a safe operating level. When EN is high, the OTG switch is activated and the FLT pin indicates whether there is a fault condition. The soft start feature waits 16 ms to turn on the OTG switch after all operating conditions are met.

Device Information⁽¹⁾

PART NUMBER	PACKAGE	BODY SIZE (MAX)
TPD4S214	WCSP (12)	1.39 mm x 1.69 mm

(1) For all available packages, see the orderable addendum at the end of the datasheet.



Table of Contents

1 Features	1	7.12 Typical Characteristics	8
2 Applications	1	8 Detailed Description	11
3 Description	1	8.1 Overview	11
4 Simplified Schematic	1	8.2 Functional Block Diagram	11
5 Revision History	2	8.3 Feature Description	12
6 Pin Configuration and Functions	3	8.4 Device Functional Modes	17
7 Specifications	4	9 Application and Implementation	18
7.1 Absolute Maximum Ratings	4	9.1 Application Information	18
7.2 ESD Ratings	4	9.2 Typical Application	18
7.3 Recommended Operating Conditions	4	10 Power Supply Recommendations	22
7.4 Thermal Information	5	11 Layout	22
7.5 Thermal Shutdown	5	11.1 Layout Guidelines	22
7.6 Electrical Characteristics for EN, \overline{FLT} , DET, D+, D-, V _{BUS} , ID Pins	5	11.2 Layout Example	22
7.7 Electrical characteristics for UVLO / OVLO	6	12 Device and Documentation Support	23
7.8 Electrical Characteristics for DET Circuits	6	12.1 Documentation Support	23
7.9 Electrical Characteristics for OTG Switch	6	12.2 Trademarks	23
7.10 Electrical Characteristics for Current Limit and Short Circuit Protection	7	12.3 Electrostatic Discharge Caution	23
7.11 Supply Current Consumption	7	12.4 Glossary	23
		13 Mechanical, Packaging, and Orderable Information	23

5 Revision History

Changes from Revision E (January 2015) to Revision F	Page
• Added UL and CB certifications.	1
Changes from Revision D (October 2014) to Revision E	Page
• Added R _{LOAD} TEST CONDITIONS to I _{OCP} in the Electrical Characteristics for Current Limit and Short Circuit Protection table.	7
Changes from Revision C (August 2013) to Revision D	Page
• Handling Rating table, Feature Description section, Device Functional Modes, Application and Implementation section, Power Supply Recommendations section, Layout section, Device and Documentation Support section, and Mechanical, Packaging, and Orderable Information section.	1
Changes from Original (January 2013) to Revision A	Page
• Changed the Product Preview data sheet	1
Changes from Revision A (February 2013) to Revision B	Page
• Changed the device From: Product Preview To: Production data	1
Changes from Revision B (February 2013) to Revision C	Page
• YFF PACKAGE Changed the YFF package dimensions	3

6 Pin Configuration and Functions

TPD4S214 WCSP (YFF) PIN
MAPPING
(TOP SIDE/SEE-THROUGH VIEW)

	1	2	3
A	V _{OTG_N}	DET	V _{BUS}
B	V _{OTG_IN}	$\overline{\text{FLT}}$	V _{BUS}
C	EN	GND	ID
D	ADJ	D-	D+

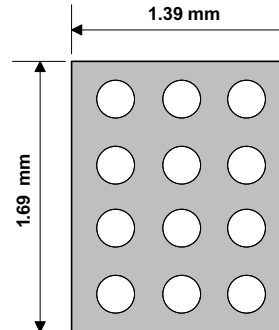

Pin Functions

NAME	PIN	TYPE	DESCRIPTION
D-	D2	I/O	USB data-
D+	D3	I/O	USB data+
ID	C3	I/O	USB ID signal
$\overline{\text{FLT}}$	B2	O	Open-Drain Output. Connect a pull-up resistor from $\overline{\text{FLT}}$ to the supply voltage of the host system.
ADJ	D1	I	Attach external resistor to adjust the current limit
EN	C1	I	Enable Input. Drive EN high to enable the OTG switch.
V _{BUS}	A3, B3	O	USB Power Output
V _{OTG_IN}	A1, B1	I	USB OTG Supply Input
DET	A2	O	Open-Drain Output. Connect a pull-up resistor from DET to the supply voltage of the host system.
GND	C2	Ground	Connect to PCB ground plane

7 Specifications

7.1 Absolute Maximum Ratings

over operating free-air temperature range (unless otherwise noted)⁽¹⁾

		MIN	MAX	UNIT
T _{stg}	Storage temperature range	-40	85	°C
V _{OTG_IN} , ADJ, EN	Input voltage	-0.5	7	V
V _{BUS}	Output voltage to USB connector	-7	30	V
FLT, DET	Output voltage	-0.5	7	V
	Input clamp current V _I < 0		-50	mA
	I _{OUT} Continuous current through FLT and DET output		10	mA
	I _{GND} Continuous current through GND		100	mA
	T _{J(max)} maximum junction temperature	-65	150	°C
D+, D-, ID, V _{BUS} pins	IEC 61000-4-2 Contact Discharge at 25°C		±15	kV
D+, D-, ID, V _{BUS} pins	IEC 61000-4-2 Air-gap Discharge at 25°C		±15	kV
D+, D-, ID pins	Peak Pulse Current (tp = 8/20 μs) at 25°C		7.8	A
D+, D-, ID pins	Peak Pulse Power (tp = 8/20 μs) at 25°C		84	W

(1) Stresses beyond those listed under *Absolute Maximum Ratings* may cause permanent damage to the device. These are stress ratings only, which do not imply functional operation of the device at these or any other conditions beyond those indicated under *Recommended Operating Conditions*. Exposure to absolute-maximum-rated conditions for extended periods may affect device reliability.

7.2 ESD Ratings

		VALUE	UNIT
V _(ESD)	Electrostatic discharge	Human body model (HBM), per ANSI/ESDA/JEDEC JS-001, all pins ⁽¹⁾	±2000
		Charged device model (CDM), per JEDEC specification JESD22-C101, all pins ⁽²⁾	±500
		IEC 61000-4-2 Contact Discharge	±15000
		IEC 61000-4-2 Air-gap Discharge	
		D+, D-, ID, V _{BUS} Pins	V

(1) JEDEC document JEP155 states that 500-V HBM allows safe manufacturing with a standard ESD control process. Pins listed as 2000 V may actually have higher performance.

(2) JEDEC document JEP157 states that 250-V CDM allows safe manufacturing with a standard ESD control process. Pins listed as 500 V may actually have higher performance.

7.3 Recommended Operating Conditions

over operating free-air temperature range (unless otherwise noted)

		MIN	TYP	MAX	UNIT
T _A	Operating free-air temperature	-40		85	°C
V _{IH}	High-level input voltage EN	1.2			V
V _{IL}	Low-level input voltage EN			0.4	V
t _{EN}	EN ramp rate for proper turn on	Valid ramp rate is between 10 μs and 100 ms, rising and falling		100	ms
t _{UVLO_SLEW}	V _{OTG_IN} ramp rate for proper UVLO operation	Valid ramp rate is between 10 μs and 100 ms, rising and falling		100	ms
t _{OVLO_SLEW}	V _{BUS} ramp rate for proper OVLO operation	Valid ramp rate is between 10 μs and 100 ms, rising and falling		100	ms
T _{A_VBUS_ATT}	Time to detect V _{BUS} device attachment and turn on DET			200	ms

7.4 Thermal Information

THERMAL METRIC ⁽¹⁾		TPD4S214		UNIT
		YFF		
		12 PINS		
R _{θJA}	Junction-to-ambient thermal resistance	89.1		°C/W
R _{θJC(top)}	Junction-to-case (top) thermal resistance	0.5		
R _{θJB}	Junction-to-board thermal resistance	40.0		
ψ _{JT}	Junction-to-top characterization parameter	3.0		
ψ _{JB}	Junction-to-board characterization parameter	39.0		

(1) For more information about traditional and new thermal metrics, see the *IC Package Thermal Metrics* application report, [SPRA953](#).

7.5 Thermal Shutdown

over operating free-air temperature range (unless otherwise noted)

PARAMETER		TEST CONDITIONS	TYP	MAX	UNIT
T _{SHDN+}	Shutdown temp rising		141		°C
T _{SHDN-}	Shutdown temp falling		125		°C
T _{HYST}	Thermal-shutdown Hysteresis		16		°C
P _{MAX}	Maximum power dissipation	V _{OTG_IN} = 5 V, R _{load} = 5 Ω, EN = 5 V, R _{ADJ} = 75 KΩ		0.16	W
T _{JMAX}	Junction Temp at max power dissipation			150	°C

7.6 Electrical Characteristics for EN, $\overline{\text{FLT}}$, DET, D+, D–, V_{BUS}, ID Pins

over operating free-air temperature range (unless otherwise noted)

PARAMETER		TEST CONDITIONS	MIN	TYP	MAX	UNIT
I _{L_EN}	EN pin input leakage current	EN = 3.3 V			1	μA
I _{OL}	$\overline{\text{FLT}}$, DET pin output leakage current	$\overline{\text{FLT}}$, DET = 3.6 V			1	μA
V _{OL_FLT}	Low-level output voltage $\overline{\text{FLT}}$	V _{BUS} or V _{OTG_IN} = 5 V or 0 V I _{OL} = 100 μA			100	mV
V _{OL_DET}	Low-level output voltage DET	V _{BUS} and V _{OTG_IN} = 5 V or 0 V I _{OL} = 100 μA			100	mV
C _{EN}	Enable capacitance	V _{BIAS} = 1.8 V, f = 1 MHz, 30 mVpp ripple, V _{OTG_IN} = 5 V		4.5		pF
V _D	Diode forward voltage D+, D–, ID pins; lower clamp diode	I _O = 8 mA			0.95	V
I _{L_D}	Leakage current on D+, D–, ID Pins	D+, D–, ID = 3.3 V			100	nA
ΔC _{IO}	Differential capacitance between the D+, D– lines	V _{BIAS} = 1.8 V, f = 1 MHz, 30 mVpp ripple, V _{OTG_IN} = 5 V			0.04	pF
C _{IO}	Capacitance to GND for the D+, D– lines	V _{BIAS} = 1.8 V, f = 1 MHz, 30 mVpp ripple, V _{OTG_IN} = 5 V		1.9		pF
	Capacitance to GND for the ID lines			1.9		
V _{BR}	Breakdown voltage D+, D–, ID pins	I _{br} = 1 mA	6			V
	Breakdown voltage on V _{BUS}	I _{br} = 1 mA	33			V
R _{DYN}	Dynamic on resistance D+, D–, ID clamps			1		Ω

7.7 Electrical characteristics for UVLO / OVLO

over operating free-air temperature range (unless otherwise noted)

PARAMETER		TEST CONDITIONS	MIN	TYP	MAX	UNIT
INPUT UNDER-VOLTAGE LOCKOUT						
V _{UVLO+}	Under-voltage lock-out, input power detected threshold rising	V _{OTG_IN} increasing from 0 V to 5 V, No load on V _{BUS} pin	3.4	3.6	3.8	V
V _{UVLO-}	Under-voltage lock-out, input power detected threshold falling	V _{OTG_IN} decreasing from 5 V to 0 V, No load on V _{BUS} pin	3.0	3.2	3.5	V
V _{HYS-UVLO}	Hysteresis on UVLO	Δ of V _{UVLO+} and V _{UVLO-}	260			mV
T _{RUUVLO}	Recovery time from UVLO	V _{OTG_IN} increasing from 0V to 5V, No load on V _{BUS} pin; time from V _{OTG_IN} = V _{UVLO+} to $\overline{\text{FLT}}$ toggles high	18			ms
T _{RESP_UVLO}	Response time for UVLO	V _{OTG_IN} decreasing from 5V to 0V, No load on V _{BUS} pin; time from V _{OTG_IN} = V _{UVLO-} to $\overline{\text{FLT}}$ toggles low	0.18			μs
OUTPUT OVERVOLTAGE LOCKOUT						
V _{OVP+}	OVLO rising threshold	Both V _{OTG_IN} and V _{BUS} increasing from 5 V to 7 V	5.55	6.15	6.45	V
V _{OVP-}	OVLO falling threshold	Both V _{OTG_IN} and V _{BUS} decreasing from 7 V to 5 V	5.4	6	6.3	V
V _{HYS-OVP}	Hysteresis on OVLO	Δ of V _{UVLO+} and V _{UVLO-}	100			mV
T _{ROVLO}	Recovery time from OVLO	Both V _{OTG_IN} and V _{BUS} decreasing from 7 V to 5 V, V _{OTG_IN} = 5 V; time from V _{BUS} = V _{OVP-} to $\overline{\text{FLT}}$ toggles high	9			ms
T _{RESP_OVLO}	Response time for OVLO	Both V _{OTG_IN} and V _{BUS} increasing from 5 V to 7 V, V _{OTG_IN} = 5 V; time from V _{BUS} = V _{OVP+} to $\overline{\text{FLT}}$ toggles low	17			μs

7.8 Electrical Characteristics for DET Circuits

over operating free-air temperature range (unless otherwise noted)

PARAMETER		TEST CONDITIONS	MIN	TYP	MAX	UNIT
V _{BUS_VALID-}	Valid V _{BUS} voltage detect	V _{BUS} = 7 V to 0 V	2.7	2.9	3	V
V _{BUS_VALID+}	Valid V _{BUS} voltage detect	V _{BUS} = 0 V to 7 V	5.3	5.4	5.6	V
T _{DET_DELAY-}	V _{BUS} detect propagation delay-	V _{BUS} 0 V to 4 V, 200 ns ramp; V _{BUS} = V _{BUS_VALID-} MIN to DET toggles high	4.9			μs
T _{DET_DELAY+}	V _{BUS} detect propagation delay+	V _{BUS} 6 V to 4 V, 200 ns ramp; V _{BUS} = V _{BUS_VALID+} MAX to DET toggles low	1.8			μs

7.9 Electrical Characteristics for OTG Switch

over operating free-air temperature range (unless otherwise noted)

PARAMETER		TEST CONDITIONS	MIN	TYP	MAX	UNIT	
R _{DS_ON}	OTG switch resistance	T _A = 25 °C, V _{BUS} = 5 V, I _{OUT} = 100 mA, R _{ADJ} = 75 kΩ ⁽¹⁾	263			290	mΩ
V _{DROP}	OTG switch voltage drop	V _{BUS} = 5 V, I _{OUT} = 100 mA, R _{ADJ} = 75 kΩ	12.6			29	mV
I _{OTG_OFF_30V}	Leakage current at 30V	Measured at V _{OTG_IN}	V _{BUS} = 30 V, EN = 5 V, V _{OTG_IN} = 5 V			6	μA
I _{OTG_OFF_2V}	Leakage current at -2V		V _{BUS} = 30 V, EN = 5 V, V _{OTG_IN} = 0 V			11	nA
I _{OTG_OFF}	Standby Leakage current		V _{BUS} = -2 V, EN = 5 V, V _{OTG_IN} = 5 V			30	μA
			V _{BUS} = 0 V, EN = 0 V, V _{OTG_IN} = 5 V			32	μA
I _{BUS_REV}	Reverse Leakage current		V _{BUS} = 5 V, EN = 0 V, V _{OTG_IN} = 0 V			10	nA
			V _{BUS} = 5 V, EN = 5 V, V _{OTG_IN} = 0V			1	nA
V _{BUS} = 5.5 V, EN = 5 V, V _{OTG_IN} = 5 V			6			μA	
T _{ON}	Turn-ON time	R _L = 100 Ω, C _L = 1 μF, R _{ADJ} = 75 kΩ	16			ms	
T _{OFF_EN}	Turn-OFF time	R _L = 100 Ω, C _L = 1 μF, R _{ADJ} = 75 kΩ, toggle EN	80			μs	
T _{OFF_OTG}	Turn-OFF time	R _L = 100 Ω, C _L = 1 μF, R _{ADJ} = 75 kΩ, toggle V _{OTG_IN}	0.5			μs	
T _{RISE}	Output rise time	R _L = 100 Ω, C _L = 1 μF, R _{ADJ} = 75 kΩ	137			μs	
T _{FALL}	Output fall time	R _L = 100 Ω, C _L = 1 μF, R _{ADJ} = 75 kΩ	1.6			μs	

(1) R_{DS(ON)} is measured at 25°C

7.10 Electrical Characteristics for Current Limit and Short Circuit Protection

over operating free-air temperature range (unless otherwise noted)

PARAMETER		TEST CONDITIONS		MIN	TYP	MAX	UNIT
I _{OCP}	Current-limit threshold (maximum DC output current I _{OUT} delivered to load)	V _{OTG_IN} = 5 V, R _{LOAD} = 2.0 Ω	R _{ADJ} = 226 kΩ ⁽¹⁾	235	245	281	mA
			R _{ADJ} = 75 kΩ ⁽¹⁾	735	792	830	
			R _{ADJ} = 62 kΩ ⁽¹⁾	885	959	1005	
			R _{ADJ} = 45 kΩ ⁽¹⁾	1128	1200	1363	
T _{BLANK}	Blanking time after enable	V _{OTG_IN} = 5 V	RL = 1 Ω, CL = 1 μF, RADJ = 75 kΩ		4		ms
T _{DEGL}	Deglintch time while enabled	V _{OTG_IN} = 5 V, RL = 100 Ω, CL = 1 μF, RADJ = 75 kΩ, apply short to ground			9.4		ms
T _{DET_SC}	Response time to short circuit				10		μs
T _{REG}	Short circuit regulation time		Hiccup pulse width; auto-retry time		13		ms
T _{OCP}	Short circuit over current protection time		Hiccup pulse period		153		ms
V _{SHORT}	Short circuit threshold				4		V
I _{INRUSH}	Inrush current during a startup	See Figure 23 under test configuration	RL = 100 Ω, CL = 22 μF, RADJ = 75 kΩ		726		mA

(1) External resistor tolerance is ±1%

7.11 Supply Current Consumption

over operating free-air temperature range (unless otherwise noted)

PARAMETER		TEST CONDITIONS		TYP	MAX	UNIT
I _{VOTG_INON}	High-level V _{OTG_IN} operating current consumption	V _{OTG_IN} = 5 V, No load on V _{BUS} , EN = 5 V	RADJ = 75 kΩ	162	200	μA
			RADJ = 226 kΩ	150	200	μA

7.12 Typical Characteristics

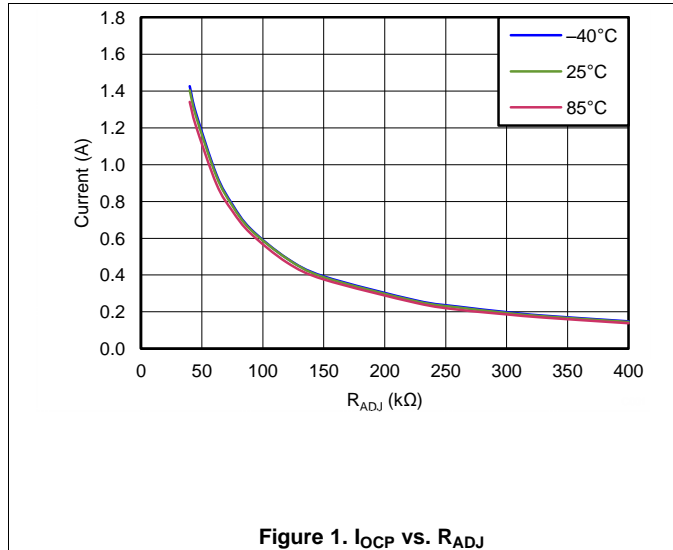

Figure 1. I_{OCP} vs. R_{ADJ}

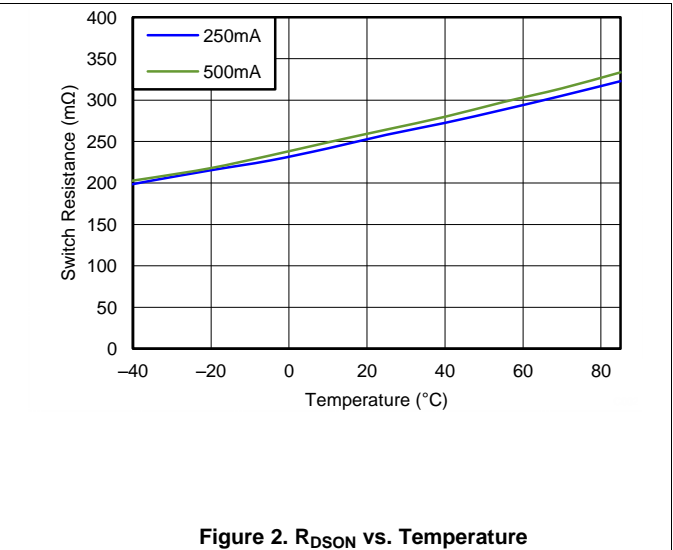

Figure 2. $R_{DS(on)}$ vs. Temperature

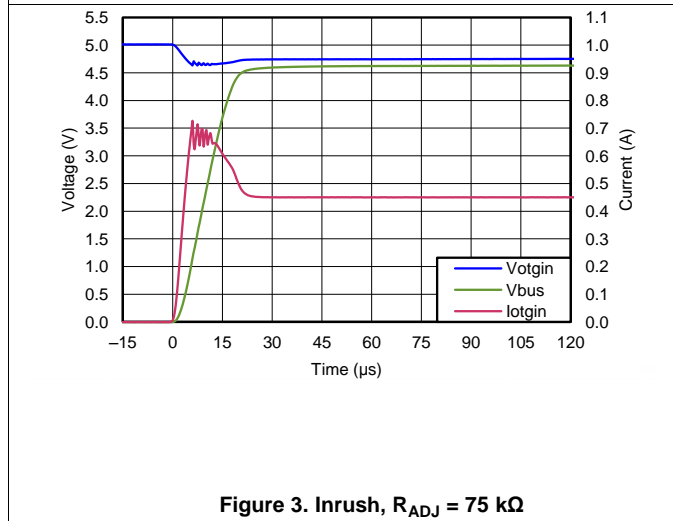

Figure 3. Inrush, $R_{ADJ} = 75 \text{ k}\Omega$

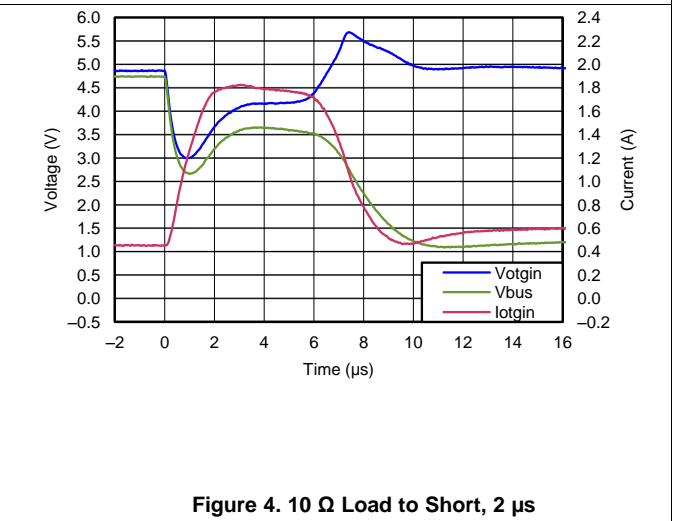

Figure 4. 10Ω Load to Short, $2 \mu\text{s}$

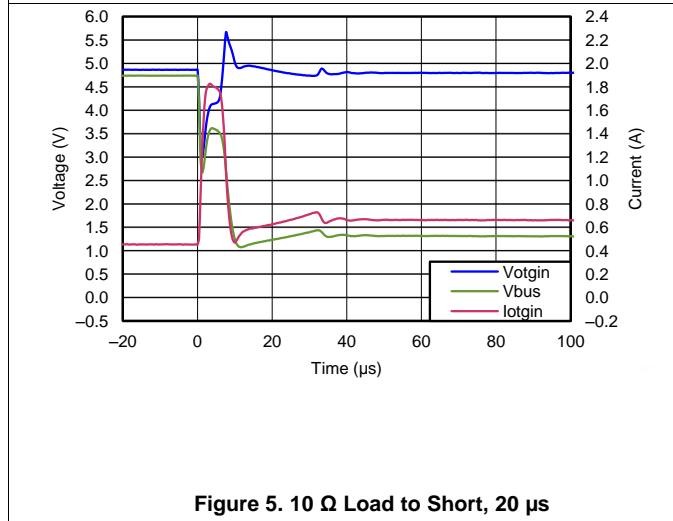

Figure 5. 10Ω Load to Short, $20 \mu\text{s}$

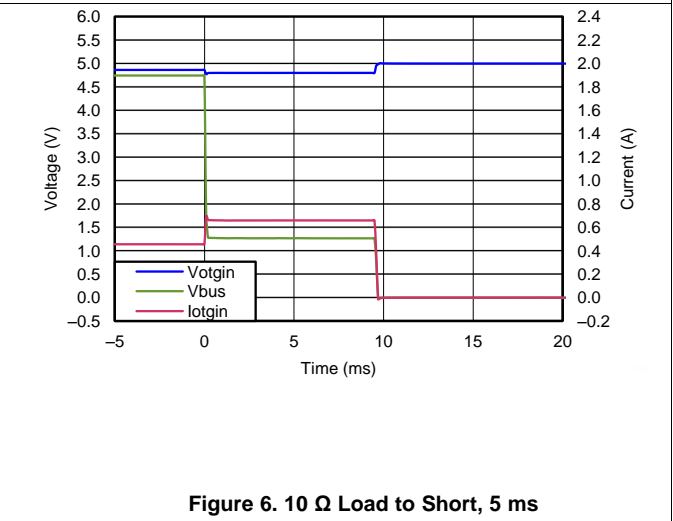

Figure 6. 10Ω Load to Short, 5 ms

Typical Characteristics (continued)

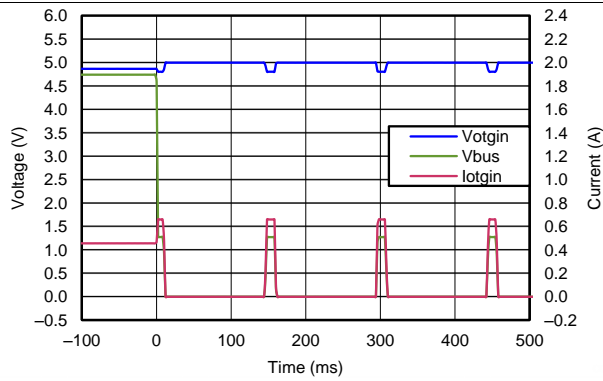

Figure 7. 10 Ω Load to Short, 100 ms

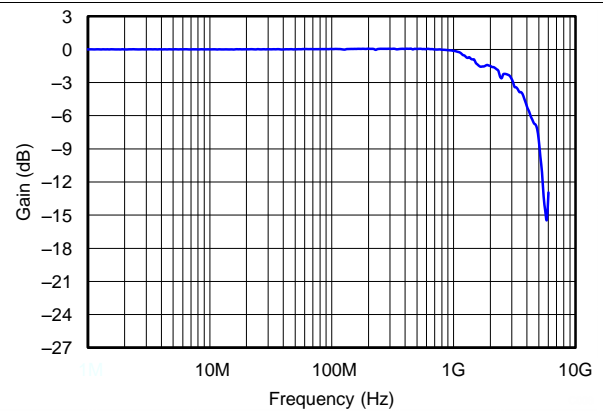

Figure 8. Data Line Insertion Loss

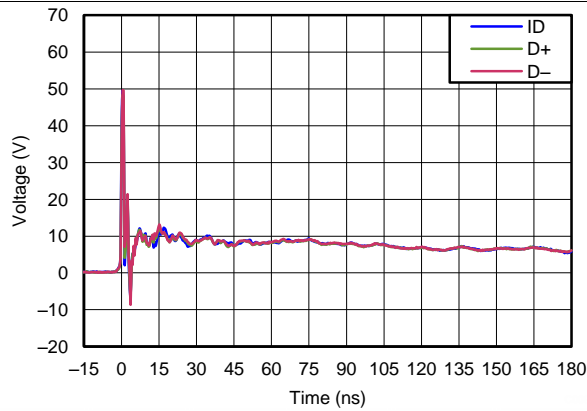

Figure 9. +8 kV Contact, 1 GHz

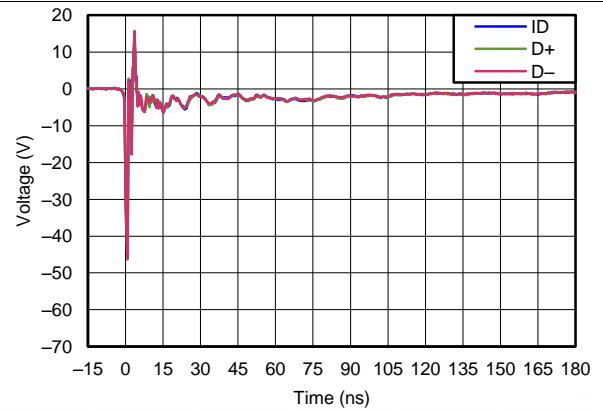

Figure 10. -8 kV Contact, 1 GHz

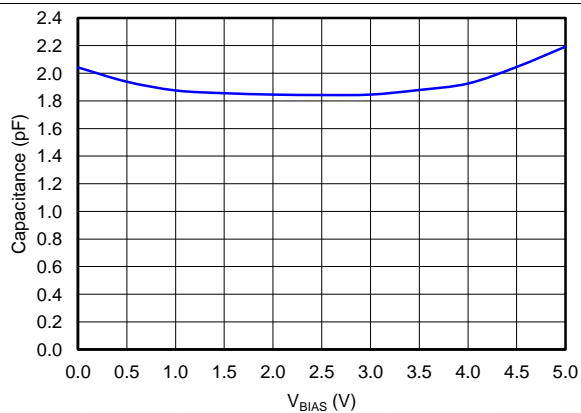

Figure 11. C_{IO} vs. V_{BIAS}, f = 1 MHz

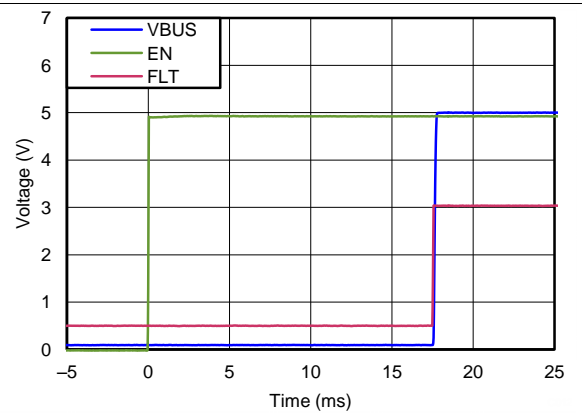

Figure 12. TPD4S214 Turn On Characteristics

Typical Characteristics (continued)

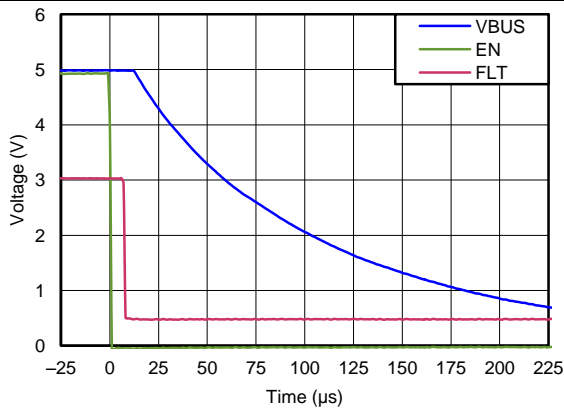

Figure 13. TPD4S214 Turn Off Characteristics

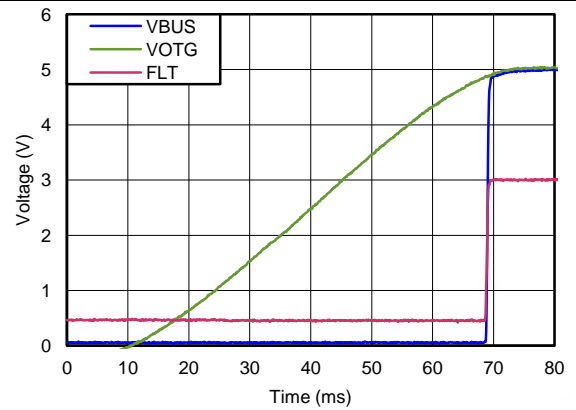

Figure 14. UVLO

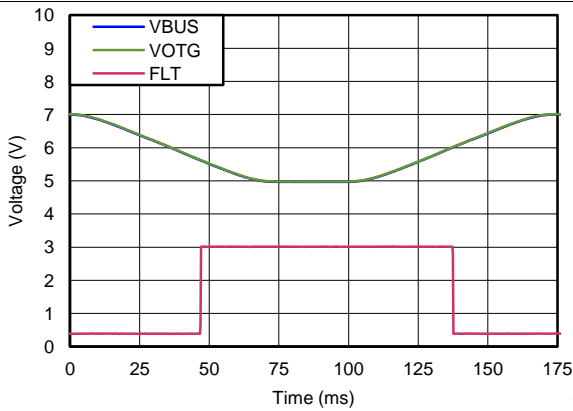

Figure 15. OVLO

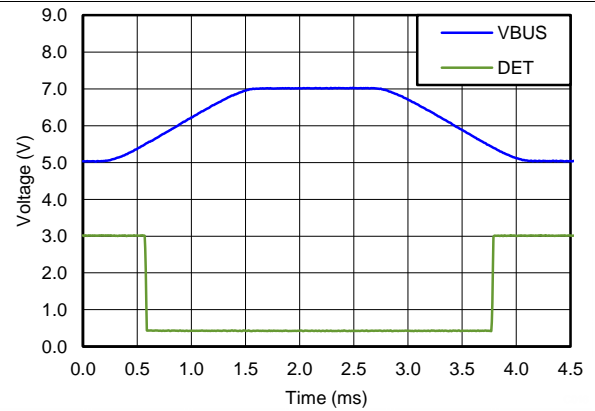

Figure 16. V_{BUS} Valid Detect Upper

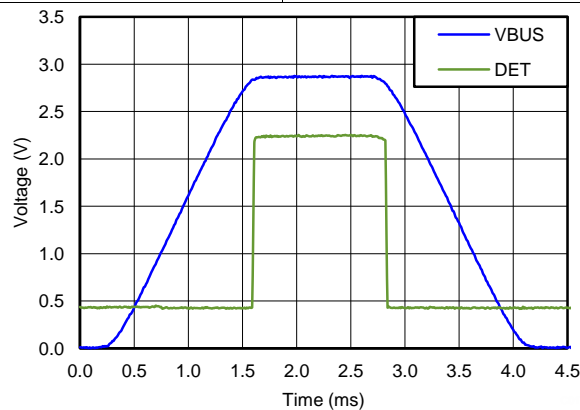

Figure 17. V_{BUS} Valid Detect Lower

8 Detailed Description

8.1 Overview

The TPD4S214 is a single-chip protection solution for USB On-the-Go and other current limited USB applications. This device includes an integrated low $R_{DS(ON)}$ N-channel current limited switch for OTG current supply to peripheral devices. TPD4S214 offers low capacitance TVS ESD clamps for the D+, D-, and ID pins for both USB2.0 and USB3.0 applications. The V_{BUS} pin can handle continuous voltage ranging from -7 V to 30 V. The OVLO at the V_{BUS} pin ensures that if there is a fault condition at the V_{BUS} line, TPD4S214 is able to isolate it and protect the internal circuitry from damage. Similarly, the UVLO at the V_{OTG_IN} pin ensures that there is no power drain from the internal OTG supply to external V_{BUS} if V_{OTG_IN} droops below a safe operating level.

When EN is high, the OTG switch is activated and the \overline{FLT} pin indicates whether there is a fault condition. The soft start feature waits 16 ms to turn on the OTG switch after all operating conditions are met. The \overline{FLT} pin asserts low during any one of the following fault conditions: OVLO ($V_{BUS} > V_{OVLO}$), UVLO condition ($V_{OTG_IN} < V_{UVLO}$) over temperature, over current, short circuit condition, or reverse-current-condition ($V_{BUS} > V_{OTG_IN}$). The OTG switch is turned off during any fault condition. Once the switch is turned off, the IC periodically rechecks the faults internally. If the IC returns to normal operating conditions, the switch turns back on and \overline{FLT} is reset to high.

There is also a V_{BUS} detection feature for facilitating USB communication between USB host and peripheral device. If this is not used, the DET pin can be either floating or connected to ground.

8.2 Functional Block Diagram

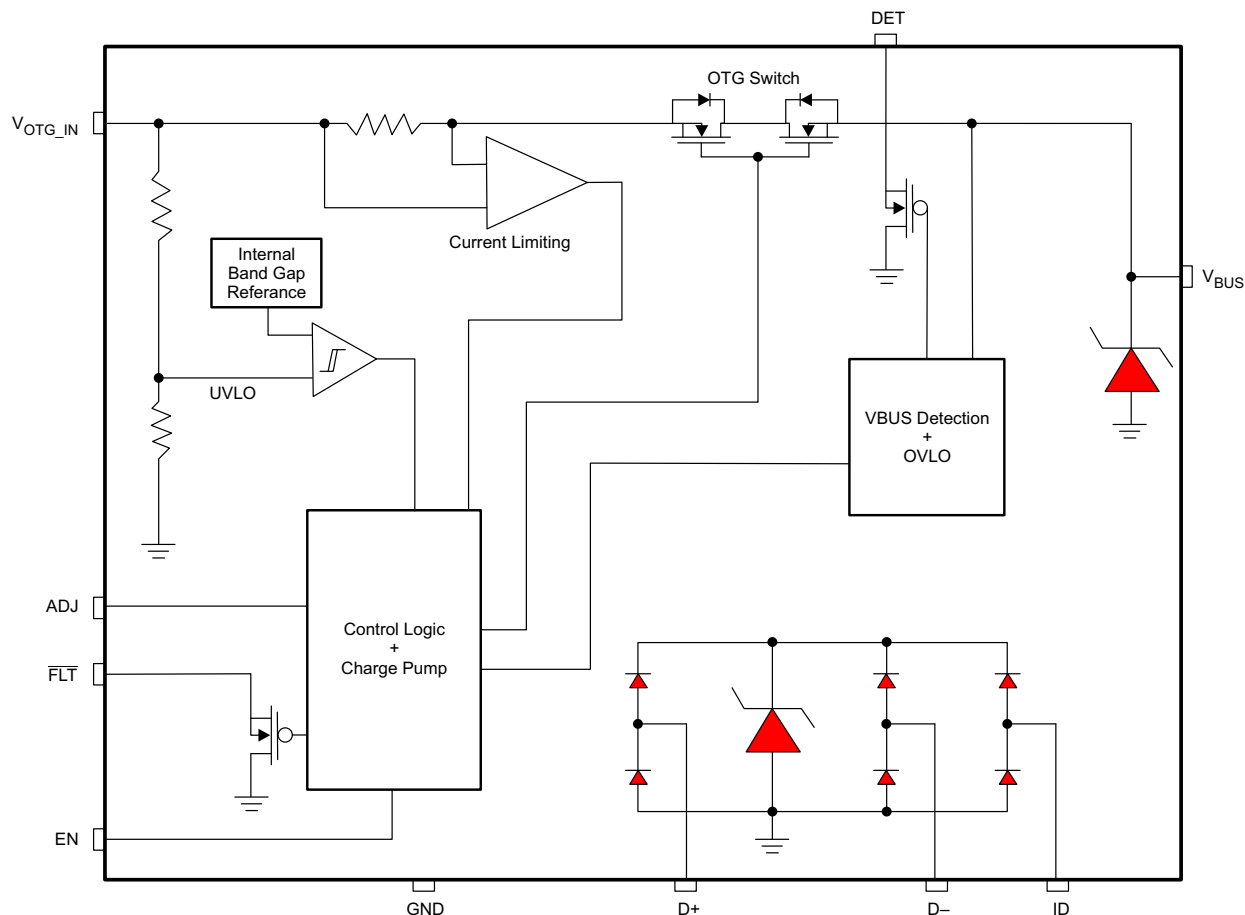

8.3 Feature Description

8.3.1 Input Voltage Protection at V_{BUS} from -7 V to 30 V

The V_{BUS} pin can handle continuous voltage ranging from -7 V to 30 V . The OVLO at the V_{BUS} pin ensures that if there is a fault condition at the V_{BUS} line, TPD4S214 is able to isolate the fault and protect the internal circuitry from damage.

8.3.2 IEC 61000-4-2 Level 4 ESD Protection

The I/O pins can withstand ESD events up to $\pm 15\text{-kV}$ contact and air gap. An ESD clamp diverts the current to ground.

8.3.3 Low $R_{DS(ON)}$ N-CH FET Switch for High Efficiency

A Low $R_{DS(ON)}$ ensures there is minimal voltage loss when supplying high current to OTG devices.

8.3.4 Compliant with USB2.0 and USB3.0 OTG spec

The capability of TPD4S214 to supply greater than 1.2 A of current on V_{BUS} meets or exceeds the USB2.0 and USB3.0 OTG specification.

8.3.5 User Adjustable Current Limit From 250 mA to Beyond 1.2 A

The designer can select the over current protection level by selecting the proper R_{ADJ} .

8.3.6 Built-in Soft-start

The soft start feature waits 16 ms to turn on the OTG switch after all operating conditions are met.

8.3.7 Reverse Current Blocking

If V_{BUS} is greater than V_{OTG_IN} by 50 mV , the OTG switch is disabled in 17.5 ms .

8.3.8 Over Voltage Lock Out for V_{BUS}

OVLO ensures that an over voltage condition on V_{BUS} disables the OTG switch to protect the system.

8.3.9 Under Voltage Lock Out for V_{OTG_IN}

UVLO ensures that an under voltage condition on V_{BUS} disables the OTG switch to protect the system.

8.3.10 Thermal Shutdown and Short Circuit Protection

TPD4S214 has an over-temperature protection circuit to protect against system faults or improper use. The basic function of the thermal shutdown (TSD) circuit is to sense when the junction temperature has exceeded the absolute maximum rating and shut down the device until the junction temperature has cooled to a safe level. Short circuit protection prevents any damaging current demand from the system.

8.3.11 Auto Retry on any Fault; no Latching off States

In any fault condition, TPD4S214 will reassess V_{BUS} , V_{OTG_IN} , and thermal conditions until a safe state is reached and then enable the OTG switch, eliminating any latched off states.

8.3.12 Integrated V_{BUS} Detection Circuit

TPD4S214 has a V_{BUS} detection feature facilitating communication between the USB host and peripheral device. The use of this feature is optional.

8.3.13 Low Capacitance TVS ESD Clamp for USB2.0 High Speed Data Rate

The High Speed data lines have a capacitance less than 2 pF , supporting a bandwidth greater than 3 GHz . This easily accommodates the 480-Mbps data rate defined in the USB2.0 specification.

Feature Description (continued)

8.3.14 Internal 16ms Startup Delay

The built-in start up delay allows for voltages on V_{BUS} to reach a steady state after which a 1- μ A trickle charge slowly turns on the main switch. During the inrush period, the peak inrush current will be limited to no more than the current limit set by the external resistor R_{ADJ} .

8.3.15 Space Saving WCSP (12-YFF) Package

The 1.69 mm \times 1.39 mm (Max) WCSP package is valuable in space constrained designs.

8.3.16 Inrush Current Protection

As soon as TPD4S214 is enabled, its logic block detects the presence of any fault conditions highlighted in [Table 2](#). In the absence of any fault condition, a counter waits for 16 ms, after which a 1- μ A trickle charge slowly turns on the main switch. During the inrush period, the peak inrush current will be limited to no more than the current limit set by the external resistor R_{ADJ} .

8.3.17 Input Capacitor (Optional)

To limit the voltage drop on the input supply caused by transient in-rush currents when the switch turns on into a discharged load capacitor or short-circuit, a capacitor needs to be placed between V_{OTG_IN} and GND. A 10- μ F ceramic capacitor, C_{IN} , placed close to the pins, is usually sufficient. Higher values of C_{IN} can be used to further reduce the voltage drop during high-current application. When switching heavy loads, it is recommended to have an input capacitor about 10 times higher than the output capacitor to avoid excessive voltage drop.

8.3.18 Output Capacitor (Optional)

Due to the integrated body diode in the NMOS switch, a C_{IN} greater than C_{LOAD} is highly recommended. A C_{LOAD} greater than C_{IN} can cause V_{BUS} to exceed V_{OTG_IN} when the system supply is removed. A C_{IN} to C_{LOAD} ratio of 10 to 1 is recommended for minimizing V_{OTG_IN} dip caused by inrush currents during startup.

8.3.19 Current Limit

The TPD4S214 provides current limiting protection, which is set by an external resistor connected from the ADJ pin to ground shown in [Figure 18](#). The current limiting threshold I_{OCP} is set by the external resistor R_{ADJ} . [Figure 19](#) shows the typical current limit for a corresponding R_{ADJ} value with $\pm 1\%$ tolerance across the operating temperature range.

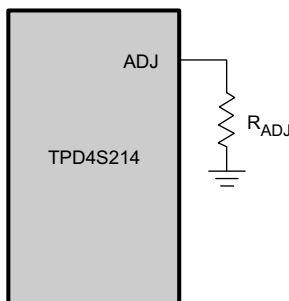

Figure 18. Current Limit Diagram

$$R_{ADJ} = \frac{55.358}{I_{OCP}} \quad (1)$$

Where:

R_{ADJ} = external resistor used to set the current limit (k Ω)

I_{OCP} = current limit set by the external R_{ADJ} resistor (A)

R_{ADJ} is placed between the ADJ pin and ground, shown in [Figure 18](#), providing a maximum current limit between 250 mA and 1.2 A.

Feature Description (continued)

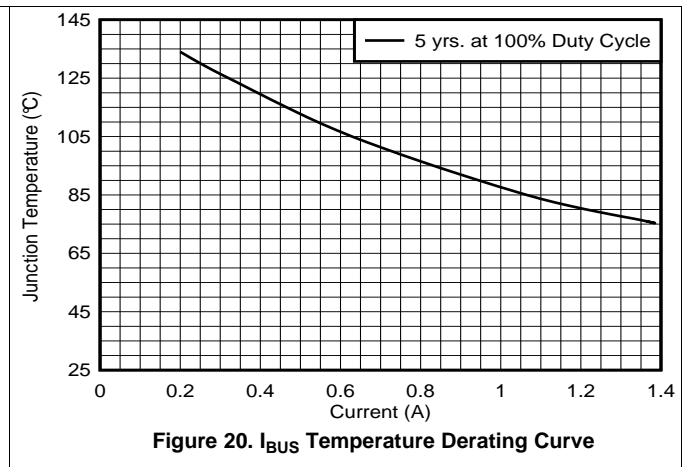
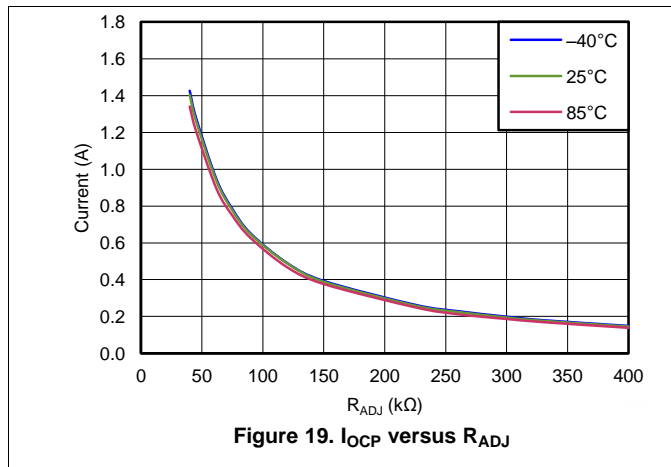

The temperature derating curve shown in [Figure 20](#) graphs the line where TPD4S214 will have a Mean Time Before Failure (MTBF) of 5 years at a 100% duty cycle for a given junction temperature, T_j , and current on V_{BUS} , or I_{BUS} . MTBF of 5 years at a 100% duty cycle is equivalent to 7.5 years at a 75% duty cycle, or 10 years at a 50% duty cycle. See [Equation 2](#) to calculate the junction temperature. If a current and junction temperature point lie below the curve on the graph then the MTBF will exceed 5 years at a 100% duty cycle, or its equivalent. If above the curve, the MTBF will be decreased.

8.3.20 Thermal Shutdown

When the device is ON, current flowing through the device will cause the device to heat up. Overheating can lead to permanent damage to the device. To prevent this, an over temperature protection has been designed into the device. Whenever the junction temperature exceeds 141°C, the switch will turn off, thereby limiting the temperature. Once the device cools down to below 125°C the switch will turn on if the EN is active and the V_{BUS} voltage is within the UVLO and OVP thresholds. While the over temperature protection in the device will not kick-in unless the die temperature reaches 141°C, it is generally recommended that care is taken to keep the junction temperature below 125°C. Operation of the device above 125°C for extended periods of time can affect the long-term reliability of the part.

The junction temperature of the device can be calculated using the below formula:

$$T_j = T_A + P_D R_{\theta JA} \tag{2}$$

Where:

T_j = Junction temperature

T_A = Ambient temperature

$R_{\theta JA}$ = Thermal resistance

P_D = Power Dissipated in device

$$P_D = I^2 R_{DS(ON)} \tag{3}$$

I = Current through device

$R_{DS(ON)}$ = Max on resistance of device

Example

At 0.5 A, the continuous current power dissipation is given by:

$$P_D = 0.5^2 \times 0.3 = 0.075 \text{ W} \tag{4}$$

If the ambient temperature is about 85 °C the junction temperature will be:

$$T_j = 85 + (0.075 \times 89.1) = 91.7^\circ\text{C} \tag{5}$$

Feature Description (continued)

This implies that, at an ambient temperature of 85°C, TPD4S214 can pass a continuous 0.5 A without sustaining damage. Conversely, the above calculation can also be used to calculate the total continuous current the TPD4S214 can handle at any given temperature.

The MTBF can be estimated by examining [Figure 20](#). Locating 0.5 A and 91.7 °C, the point is below the curve. This implies that the MTBF for this calculation is longer than 5 years at a 100% duty cycle. If the duty cycle is 50% then MTBF exceeds 10 years.

8.3.21 V_{BUS} Detection

There are several important protocols defined in [OTG and EH Supplement] that governs communication between Targeted Hosts (A-device) and USB peripherals (B-device). Communication between host and peripheral is usually done on the ID pin only. In the case when two OTG devices that could both act as either host or peripheral are connected, measuring voltage level on V_{BUS} will aid in the handshaking process. If an embedded host instead of a USB peripheral is connected to the OTG device, OTG charging would not be required and the system's OTG source should remain off to conserve power. The TPD4S214 V_{BUS} detection block aids power conservation and is powered from V_{BUS}. See [Functional Block Diagram](#). The DET pin is an open drain PMOS output with default state low.

In the event when an A-plug is attached, the system detects ID pin as FALSE, in which case ID pin resistance to ground is less than 10 Ω. For a B-plug, the system detects ID pin as TRUE and ID pin resistance to ground is greater than 100 kΩ. For the system to power a USB device through OTG switch once it is connected, voltage on V_{BUS} should remain below V_{BUS_VALID MIN} within T_{A_VBUS_ATT} of the ID pin becoming FALSE. After this event, the system confirms that the USB device requires power and enables both TPD4S214 and OTG source. However, if V_{BUS_VALID} is detected on V_{BUS} within T_{A_VBUS_ATT} of the ID pin becoming FALSE, there is either a system error or the device connected does not require charging. OTG source remains switched off and the entire sequence would restart when the system detects another FALSE on the ID pin.

Table 1. V_{BUS} Detection scheme

EN	V _{OTG_IN} (V _{BUS} Detect Power)	V _{BUS}	DET	Condition
X	X	V _{BUS_VALID-} < V _{BUS} < V _{BUS_VALID+}	H	V _{BUS} within V _{BUS_VALID}
X	X	V _{BUS_VALID-} > V _{BUS} OR V _{BUS} > V _{BUS_VALID+}	L	V _{BUS} outside of V _{BUS_VALID}

X = Don't Care, H = Signal High, and L = Signal Low

[Figure 21](#) and [Figure 22](#) shows suggested system level timing diagrams for detecting V_{BUS} according to [OTG and EH Supplement]. [Figure 28](#) shows the application diagram. In [Figure 21](#), DET pin remains low after ID pin becomes FALSE, indicating there is not an active voltage source on V_{BUS}. The USB controller proceeds to turn on OTG 5-V source and the TPD4S214 respectively; this sequence is recommended because TPD4S214 is powered through the OTG source. After a period of t_{ON}, current starts to flow through the OTG switch and V_{BUS} is ramped to the voltage level of V_{OTG_IN}.

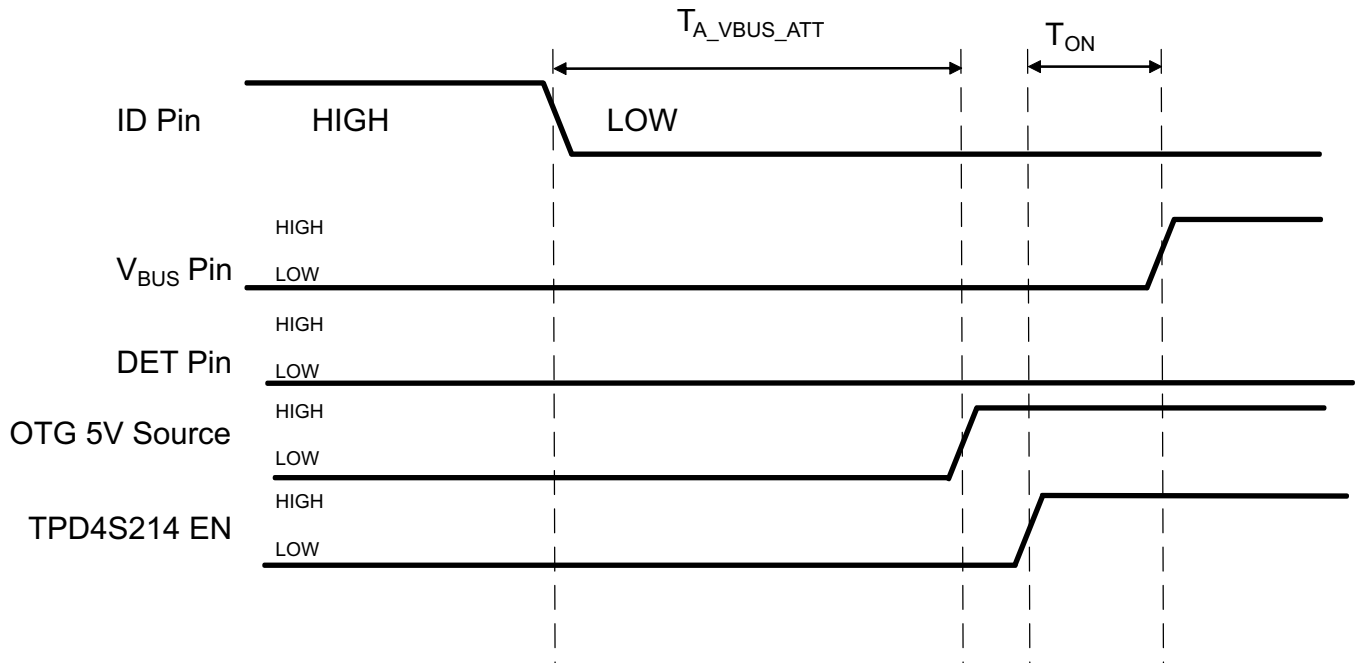
Figure 21. Timing Diagram for Valid USB Device

In [Figure 22](#), DET pin toggles high after an active voltage is detected on V_{BUS} within $T_{A_VBUS_ATT}$. This indicates that the USB device attached is not suitable for OTG charging and both OTG 5-V source and TPD4S214 remain off.

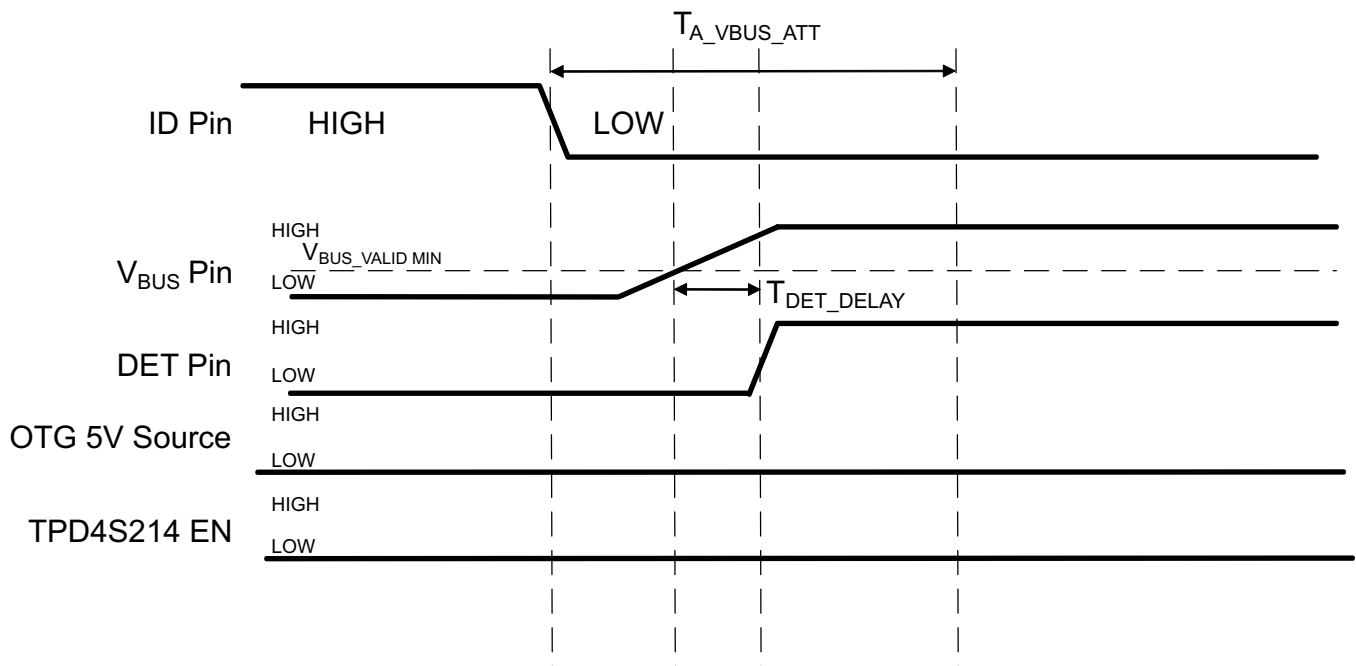
Figure 22. System Level Timing Diagram for Invalid USB Device

8.3.22 Test Configuration

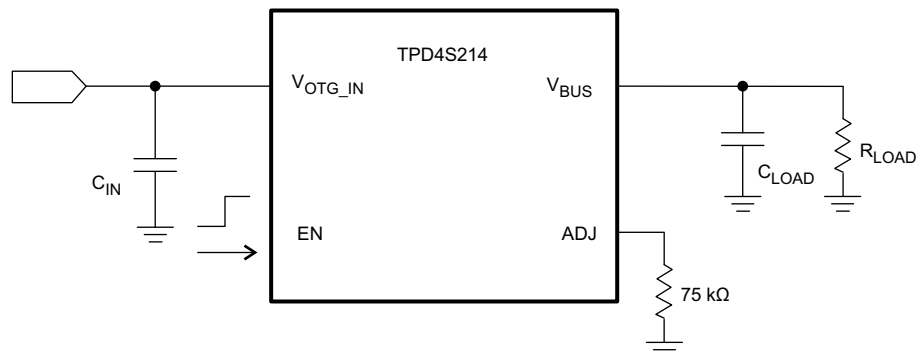

Figure 23. Inrush Current Test Configuration.

Enable is toggled from low to high. See the [Application Information](#) section for C_{IN} and C_{LOAD} value recommendations.

8.4 Device Functional Modes

Table 2. Device Operation

EN	V_{OTG_IN}	V_{BUS}	OCP	OTP	OTG SW	\overline{FLT}	FAULT CONDITION
X	0	0	F	F	OFF	L	SW Disabled
X	X	X	X	T	OFF	L	Over Temperature
H	X	X	T	X	OFF	L	Over Current
H	$V_{OTG_IN} > V_{UVLO}$	$V_{BUS} > V_{OTG_IN}$	F	F	OFF	L	Reverse-current
H	X	$V_{BUS} > V_{OVLO}$	F	F	OFF	L	V_{BUS} over-voltage
H	$V_{OTG_IN} < V_{UVLO}$	X	F	F	OFF	L	V_{OTG_IN} under-voltage
H	$V_{OTG_IN} > V_{BUS}$ and $V_{OTG_IN} > V_{UVLO}$	$V_{SHORT} < V_{BUS} < V_{OTG_IN}$ and $V_{SHORT} < V_{BUS} < V_{OVLO}$	F	F	ON	H	Normal (SW Enabled)

9 Application and Implementation

NOTE

Information in the following applications sections is not part of the TI component specification, and TI does not warrant its accuracy or completeness. TI's customers are responsible for determining suitability of components for their purposes. Customers should validate and test their design implementation to confirm system functionality.

9.1 Application Information

A USB OTG device's one and only connector is the AB receptacle, which accepts either an A or B plug. When an A-plug is inserted, the OTG device is called the A-device and when a B-plug is inserted it is called the B-device. A-device is often times referred to as "Targeted Host" and B-device as "USB peripheral". TPD4S214 supports an OTG device when TPD4S214's system is acting as an A-device and powering the USB interface. The TPD4S214 may also be used in non-OTG applications where it resides on the current source side.

9.2 Typical Application

The TPD4S214 is placed next to the USB connector to provide over voltage, over current, and ESD protection for the OTG 5-V source and USB Controller.

9.2.1 USB 2.0 Without Using On-chip V_{BUS} Detect

An example using TPD4S214 to protect an OTG 5-V source and USB 2.0 Controller is shown below. This USB Controller does not utilize V_{BUS} detection with the DET pin, so DET is tied to GND. TPD4S214 is placed in the transmitter channel immediately adjacent to the USB connector. The D+, D-, ID pins on TPD4S214 are interchangeable so that each can protect either of the D+, D-, ID pins on the USB connector, the naming convention is just a suggestion.

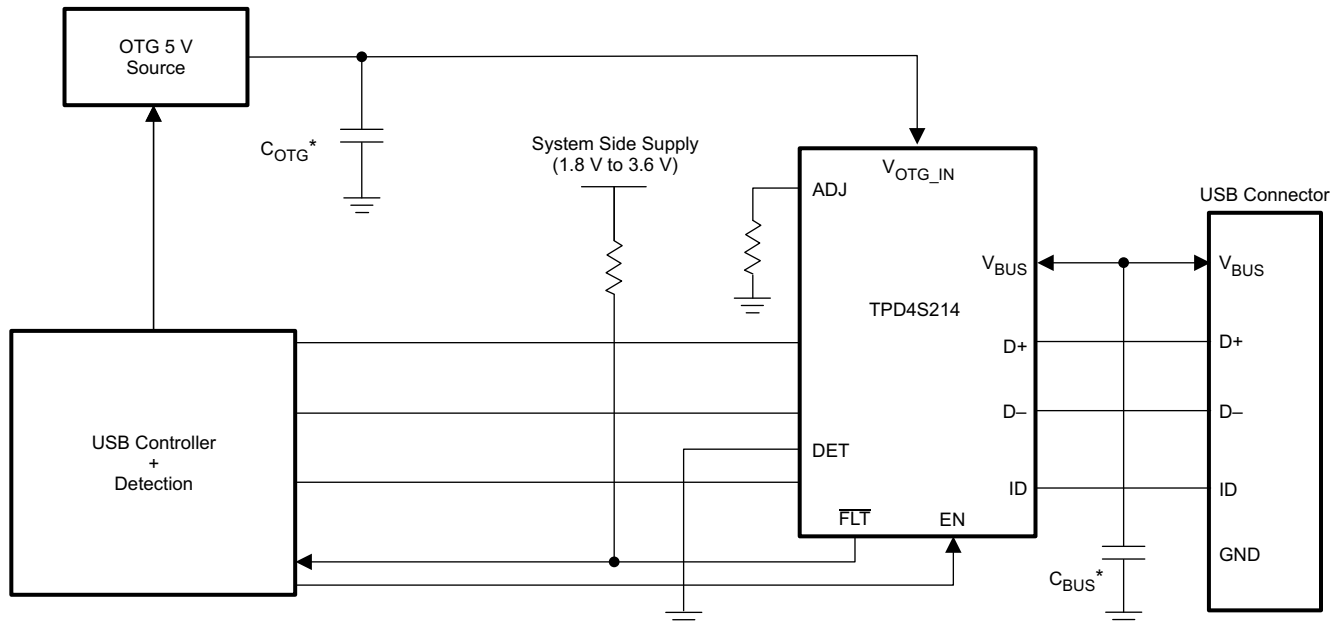

Figure 24. USB2.0 Application Diagram Without Using On-chip V_{BUS} Detect

* C_{OTG} and C_{BUS} have minimum recommended values of 1 μF each

Typical Application (continued)

9.2.1.1 Design Requirements

For this example, use the following table as input parameters:

Design Parameters	Example Value
Signal range on V_{OTG_IN}	3.8 V – 5.5 V
Signal range on V_{BUS}	0 V – 5.3 V nominal, withstand -7 V to 30 V
I_{BUS_MAX}	500 mA
R_{ADJ}	100 k Ω
Drive EN low (disabled)	0 V – 0.4 V
Drive EN high (enabled)	1.2 V – 5.5 V

9.2.1.2 Detailed Design Procedure

To begin the design process, determine the maximum current expected under normal usage. In this example, the maximum expected current is 500 mA so an R_{ADJ} of 100 k Ω was selected to begin current limiting at around 550 mA and protect the OTG system. Fault conditions are monitored by the USB controller by using the FLT Pin. DET is not used and is grounded and can optionally be left floating instead.

9.2.1.3 Application Curves

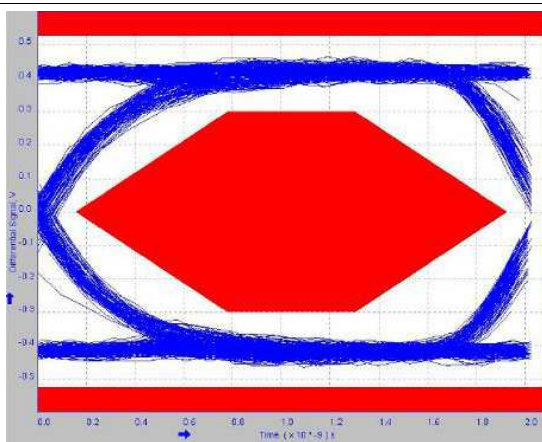

Figure 25. Eye Diagram with no EVM and no IC, Full USB2.0 Speed at 480 Mbps

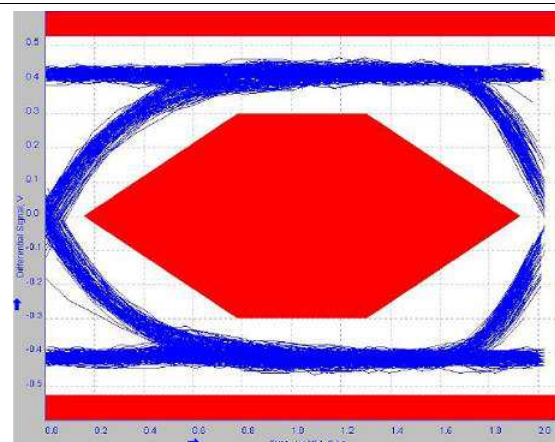

Figure 26. Eye Diagram with TPD4S214EVM but no IC, Full USB2.0 Speed at 480 Mbps

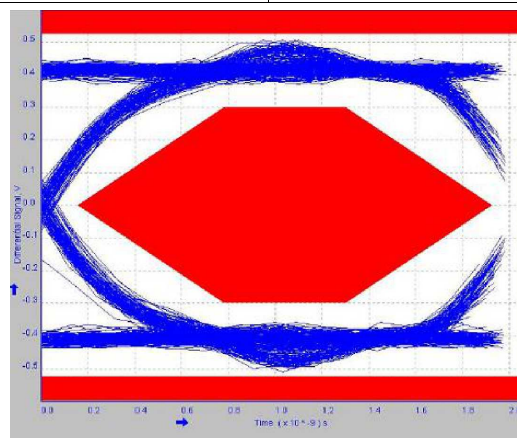

Figure 27. Eye Diagram with TPD4S214EVM and IC, Full USB2.0 Speed at 480 Mbps

9.2.2 USB 2.0 Using On-chip V_{BUS} Detect

An example using TPD4S214 to protect an OTG 5-V source and USB 2.0 Controller is shown below. This USB Controller monitors V_{BUS} detection with the DET pin. This can be advantageous when a peripheral with an Embedded Host is attached. In this case, if there is a valid voltage present on V_{BUS} there is no need to provide OTG power, so the USB Controller can be programmed to disable the OTG 5-V source, resulting in a power savings. The D+, D-, ID pins on TPD4S214 are interchangeable so that each can protect either of the D+, D-, ID pins on the USB connector, the naming convention is just a suggestion.

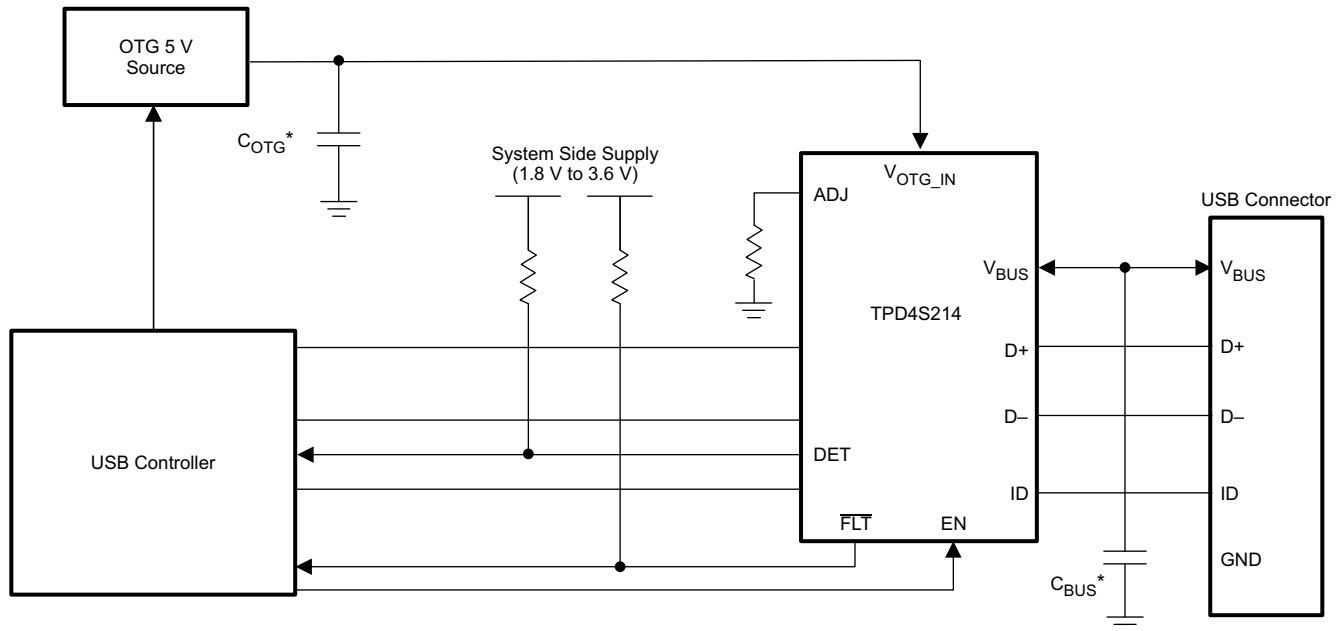

Figure 28. USB 2.0 Application Diagram Using On-chip V_{BUS} Detect

* C_{OTG} and C_{BUS} each have minimum recommended values of 1 μ F

9.2.2.1 Design Requirements

For this example, use the following table as input parameters:

Design Parameters	Example Value
Signal range on V_{OTG_IN}	3.8 V – 5.5 V
Signal range on V_{BUS}	0 V – 5.3 V nominal, withstand –7 V to 30 V
I_{BUS_MAX}	500 mA
R_{ADJ}	100 k Ω
Drive EN low (disabled)	0 V – 0.4 V
Drive EN high (enabled)	1.2 V – 5.5 V

9.2.2.2 Detailed Design Procedure

To begin the design process, determine the maximum current expected under normal usage. In this example, the maximum expected current is 500 mA so an R_{ADJ} of 100 k Ω was selected to begin current limiting at around 550 mA and protect the OTG system. Fault conditions are monitored by the USB controller by using the FLT Pin. DET Pin is used to facilitate detecting between a USB host and peripheral device on V_{BUS} .

9.2.2.3 Application Curves

Refer to [Application Curves](#) for related application curves.

9.2.3 USB 3.0 Without Using On-chip V_{BUS} Detect

An example using TPD4S214 to protect an OTG 5-V source and USB 3.0 Controller is shown below. This USB Controller does not utilize V_{BUS} detection with the DET pin, so it is tied to GND. The D+, D-, ID pins on TPD4S214 are interchangeable so that each can protect either of the D+, D-, ID pins on the USB connector, the naming convention is just a suggestion.

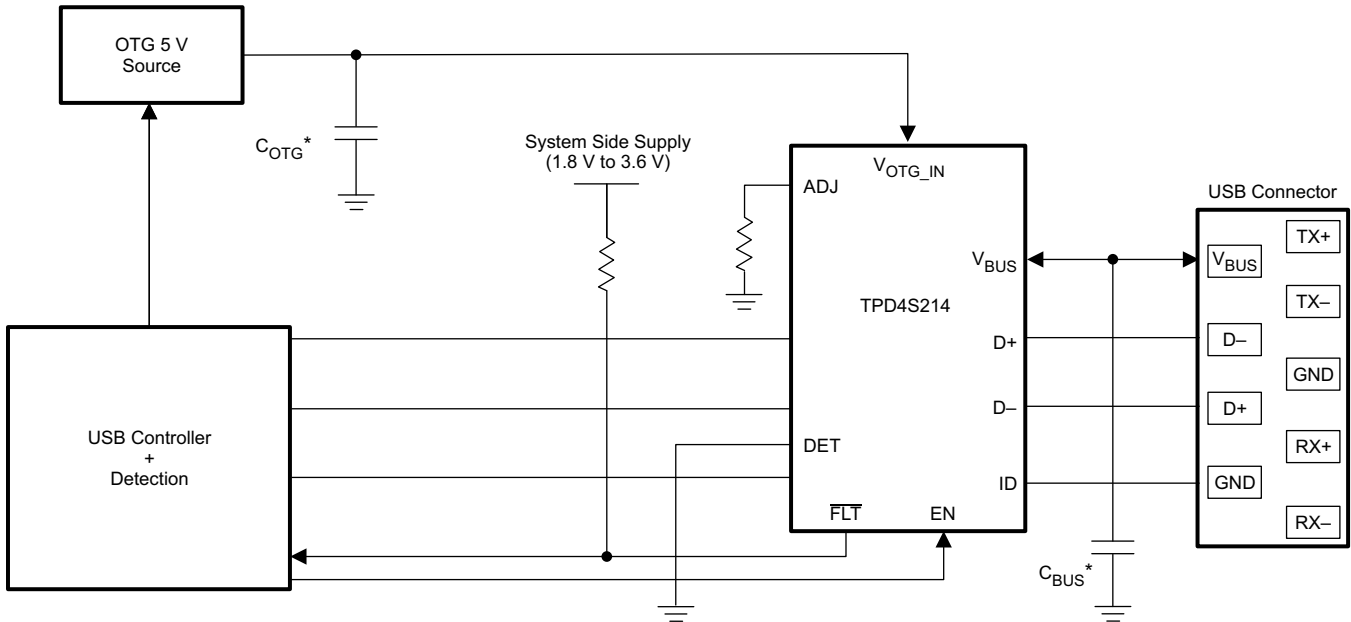

*C_{BUS} and C_{OTG} each have minimum recommended values of 1 μF

Figure 29. USB 3.0 Application Diagram Without Using On-chip V_{BUS} Detect

9.2.3.1 Design Requirements

For this example, use the following table as input parameters:

Design Parameters	Example Value
Signal range on V _{OTG_IN}	3.8 V – 5.5 V
Signal range on V _{BUS}	0 V – 5.3 V nominal, withstand –7 V to 30 V
I _{BUS_MAX}	900 mA
R _{ADJ}	56 kΩ
Drive EN low (disabled)	0 V – 0.4 V
Drive EN high (enabled)	1.2 V – 5.5 V

9.2.3.2 Detailed Design Procedure

To begin the design process, determine the maximum current expected under normal usage. In this example, the maximum expected current is 900 mA so an R_{ADJ} of 56 kΩ was selected to begin current limiting at around 1 A and protect the OTG system. Fault conditions are monitored by the USB controller by the $\overline{\text{FLT}}$ Pin. DET is not used and is grounded and can optionally be left floating instead.

9.2.3.3 Application Curves

Refer to [Application Curves](#) for related application curves.

10 Power Supply Recommendations

TPD4S214 is designed to receive power from an OTG 5-V power source. It can operate normally (nFET ON) between 3.8 V and 5.55 V. Thus, the power supply (with a ripple of V_{RIPPLE}) requirement for TPD4S214 to be able to switch the nFET ON is between $3.8\text{ V} + V_{RIPPLE}$ and $5.55\text{ V} - V_{RIPPLE}$.

11 Layout

11.1 Layout Guidelines

- The optimum placement is as close to the connector as possible.
 - EMI during an ESD event can couple from the trace being struck to other nearby unprotected traces, resulting in early system failures. Therefore, the PCB designer needs to minimize the possibility of EMI coupling by keeping any unprotected traces away from the protected traces which are between the TVS and the connector.
- Route the protected traces as straight as possible.
- Avoid using VIAs between the connector and an I/O protection pin on TPD4S214.
- Avoid 90° turns in traces.
 - Electric fields tend to build up on corners, increasing EMI coupling.
- Minimize impedance on the path to GND for maximum ESD dissipation.
- The capacitors on V_{BUS} and V_{OTG_IN} should be placed close to their respective pins on TPD4S214.

11.2 Layout Example

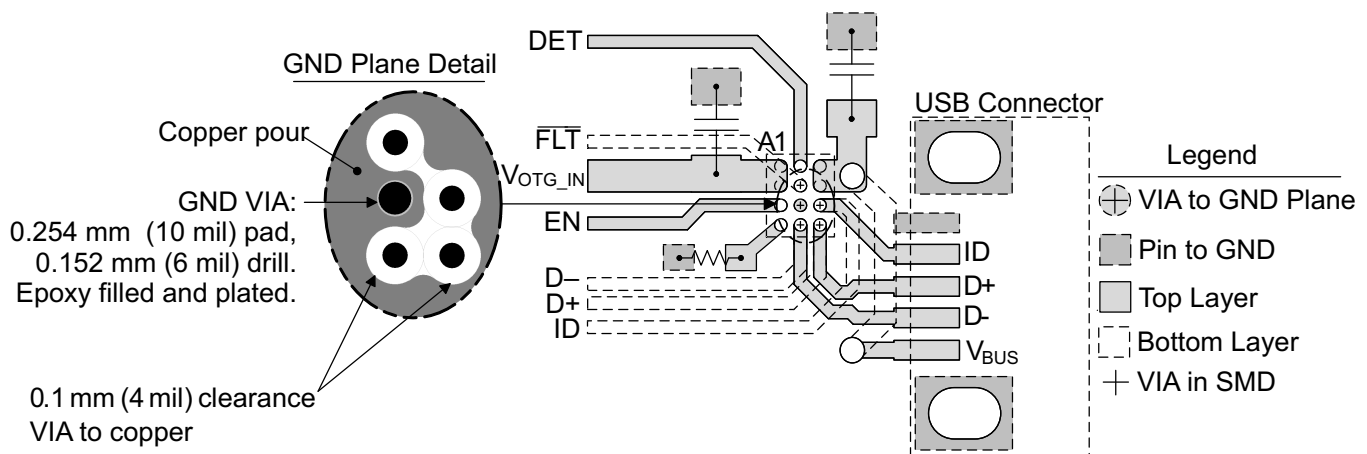

Figure 30. TPD4S214 Layout Example

Successful dissipation of an ESD event is largely dependent on minimizing the impedance along the designated electrical path to ground. For this reason any TVS, including TPD4S214, needs to have the lowest possible impedance to GND. The BGA footprint of this device constrains the path to ground through a VIA in the GND pad of TPD4S214. Due to the "skin effect," maximizing the surface area of the VIA minimizes the impedance of the path to GND. For this reason make both the VIA pad diameter and the VIA drill diameter as large as possible, thus maximizing the surface area of the outside of the VIA surface and the inside of the VIA surface. The GND plane should not be broken in the vicinity of the GND VIA. If possible, attaching the GND VIA to a GND plane on multiple layers minimizes the impedance. The GND VIA should be filled with a non-conductive filler (like epoxy) as opposed to a conductive filler, in order to keep the surface area of the inside of the VIA created by the drill. The GND VIA should be plated over at the SMD pad.

12 Device and Documentation Support

12.1 Documentation Support

12.1.1 Related Documentation

OTG and EH Supplement: *On-The-Go and Embedded Host Supplement to the USB Revision 2.0 Specification*, July 14th, 2011. www.usb.org

12.2 Trademarks

All trademarks are the property of their respective owners.

12.3 Electrostatic Discharge Caution



These devices have limited built-in ESD protection. The leads should be shorted together or the device placed in conductive foam during storage or handling to prevent electrostatic damage to the MOS gates.

12.4 Glossary

[SLYZ022](#) — *TI Glossary*.

This glossary lists and explains terms, acronyms, and definitions.

13 Mechanical, Packaging, and Orderable Information

The following pages include mechanical, packaging, and orderable information. This information is the most current data available for the designated devices. This data is subject to change without notice and revision of this document. For browser-based versions of this data sheet, refer to the left-hand navigation.

PACKAGING INFORMATION

Orderable Device	Status (1)	Package Type	Package Drawing	Pins	Package Qty	Eco Plan (2)	Lead/Ball Finish (6)	MSL Peak Temp (3)	Op Temp (°C)	Device Marking (4/5)	Samples
TPD4S214YFFR	ACTIVE	DSBGA	YFF	12	3000	Green (RoHS & no Sb/Br)	SNAGCU	Level-1-260C-UNLIM	-40 to 85	B3214	

(1) The marketing status values are defined as follows:

ACTIVE: Product device recommended for new designs.

LIFEBUY: TI has announced that the device will be discontinued, and a lifetime-buy period is in effect.

NRND: Not recommended for new designs. Device is in production to support existing customers, but TI does not recommend using this part in a new design.

PREVIEW: Device has been announced but is not in production. Samples may or may not be available.

OBSOLETE: TI has discontinued the production of the device.

(2) Eco Plan - The planned eco-friendly classification: Pb-Free (RoHS), Pb-Free (RoHS Exempt), or Green (RoHS & no Sb/Br) - please check <http://www.ti.com/productcontent> for the latest availability information and additional product content details.

TBD: The Pb-Free/Green conversion plan has not been defined.

Pb-Free (RoHS): TI's terms "Lead-Free" or "Pb-Free" mean semiconductor products that are compatible with the current RoHS requirements for all 6 substances, including the requirement that lead not exceed 0.1% by weight in homogeneous materials. Where designed to be soldered at high temperatures, TI Pb-Free products are suitable for use in specified lead-free processes.

Pb-Free (RoHS Exempt): This component has a RoHS exemption for either 1) lead-based flip-chip solder bumps used between the die and package, or 2) lead-based die adhesive used between the die and leadframe. The component is otherwise considered Pb-Free (RoHS compatible) as defined above.

Green (RoHS & no Sb/Br): TI defines "Green" to mean Pb-Free (RoHS compatible), and free of Bromine (Br) and Antimony (Sb) based flame retardants (Br or Sb do not exceed 0.1% by weight in homogeneous material)

(3) MSL, Peak Temp. - The Moisture Sensitivity Level rating according to the JEDEC industry standard classifications, and peak solder temperature.

(4) There may be additional marking, which relates to the logo, the lot trace code information, or the environmental category on the device.

(5) Multiple Device Markings will be inside parentheses. Only one Device Marking contained in parentheses and separated by a "~" will appear on a device. If a line is indented then it is a continuation of the previous line and the two combined represent the entire Device Marking for that device.

(6) Lead/Ball Finish - Orderable Devices may have multiple material finish options. Finish options are separated by a vertical ruled line. Lead/Ball Finish values may wrap to two lines if the finish value exceeds the maximum column width.

Important Information and Disclaimer: The information provided on this page represents TI's knowledge and belief as of the date that it is provided. TI bases its knowledge and belief on information provided by third parties, and makes no representation or warranty as to the accuracy of such information. Efforts are underway to better integrate information from third parties. TI has taken and continues to take reasonable steps to provide representative and accurate information but may not have conducted destructive testing or chemical analysis on incoming materials and chemicals. TI and TI suppliers consider certain information to be proprietary, and thus CAS numbers and other limited information may not be available for release.

In no event shall TI's liability arising out of such information exceed the total purchase price of the TI part(s) at issue in this document sold by TI to Customer on an annual basis.

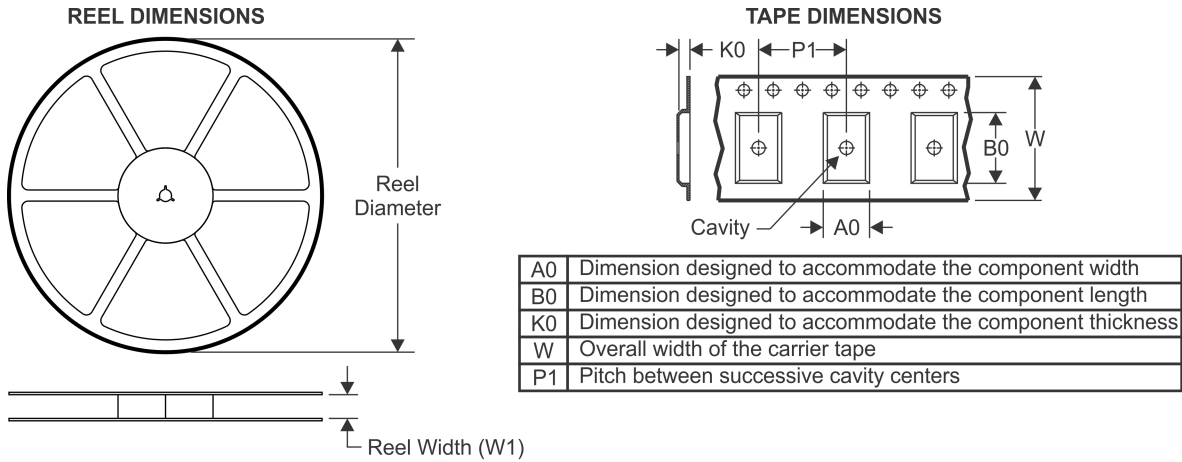
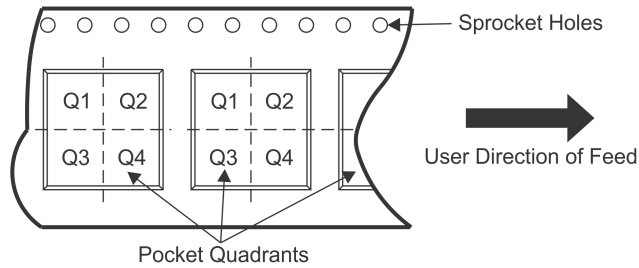
TAPE AND REEL INFORMATION

QUADRANT ASSIGNMENTS FOR PIN 1 ORIENTATION IN TAPE

*All dimensions are nominal

Device	Package Type	Package Drawing	Pins	SPQ	Reel Diameter (mm)	Reel Width W1 (mm)	A0 (mm)	B0 (mm)	K0 (mm)	P1 (mm)	W (mm)	Pin1 Quadrant
TPD4S214YFFR	DSBGA	YFF	12	3000	180.0	8.4	1.48	1.78	0.69	4.0	8.0	Q1

TAPE AND REEL BOX DIMENSIONS



*All dimensions are nominal

Device	Package Type	Package Drawing	Pins	SPQ	Length (mm)	Width (mm)	Height (mm)
TPD4S214YFFR	DSBGA	YFF	12	3000	182.0	182.0	20.0

YFF0012

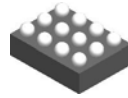

PACKAGE OUTLINE

DSBGA - 0.625 mm max height

DIE SIZE BALL GRID ARRAY

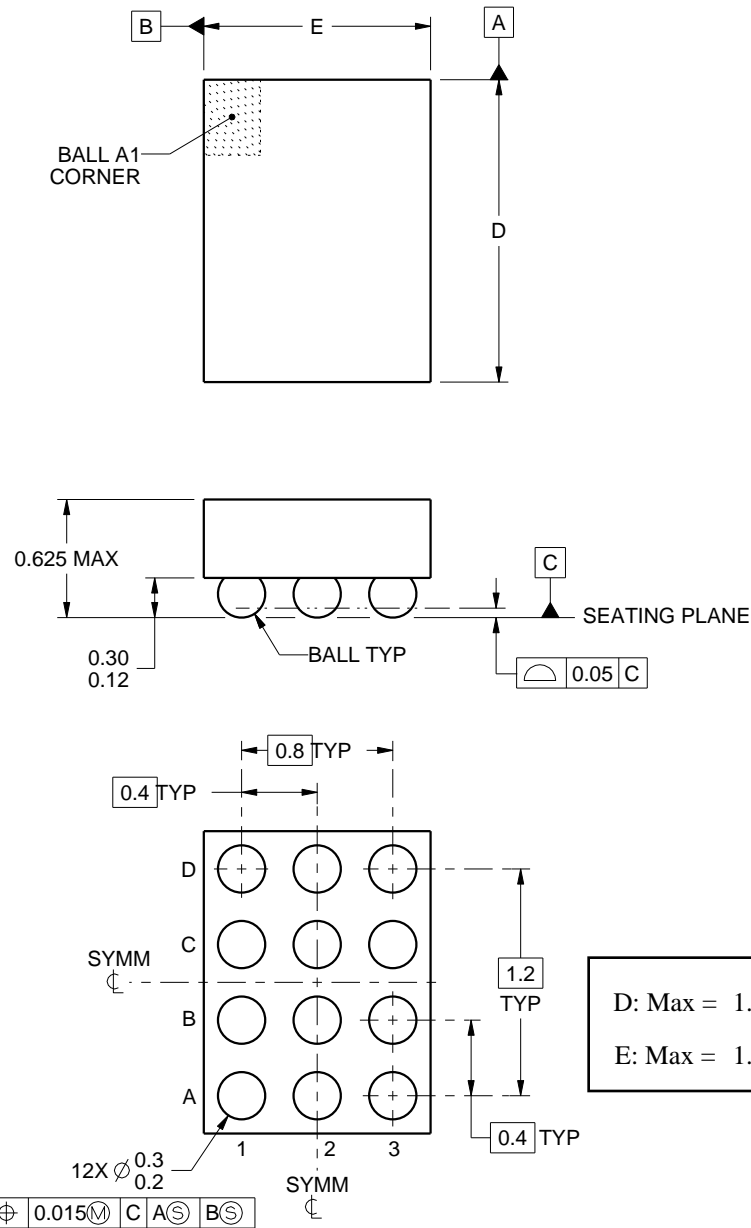

D: Max = 1.72 mm, Min = 1.66 mm
 E: Max = 1.42 mm, Min = 1.36 mm

4222191/A 07/2015

NOTES:

1. All linear dimensions are in millimeters. Any dimensions in parenthesis are for reference only. Dimensioning and tolerancing per ASME Y14.5M.
2. This drawing is subject to change without notice.

EXAMPLE BOARD LAYOUT

YFF0012

DSBGA - 0.625 mm max height

DIE SIZE BALL GRID ARRAY

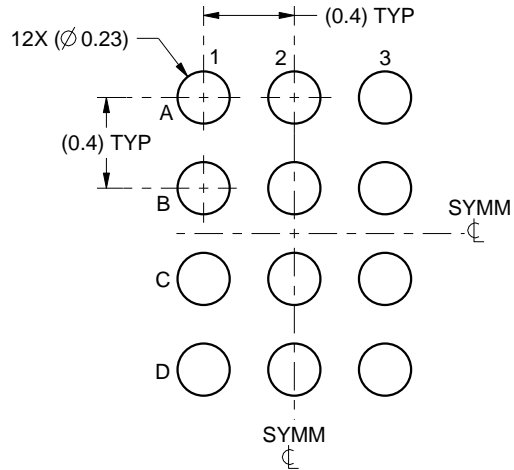

LAND PATTERN EXAMPLE
SCALE:30X

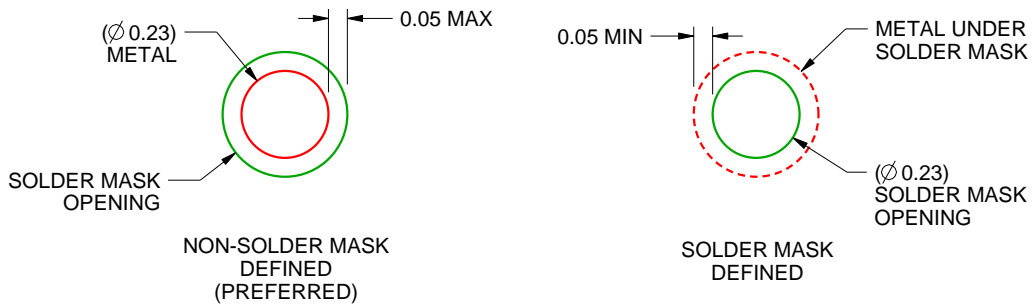

SOLDER MASK DETAILS
NOT TO SCALE

4222191/A 07/2015

NOTES: (continued)

3. Final dimensions may vary due to manufacturing tolerance considerations and also routing constraints. For more information, see Texas Instruments literature number SNVA009 (www.ti.com/lit/snva009).

EXAMPLE STENCIL DESIGN

YFF0012

DSBGA - 0.625 mm max height

DIE SIZE BALL GRID ARRAY

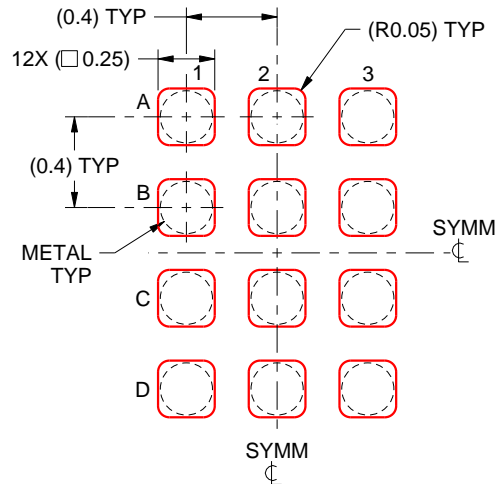

SOLDER PASTE EXAMPLE
BASED ON 0.1 mm THICK STENCIL
SCALE:30X

4222191/A 07/2015

NOTES: (continued)

4. Laser cutting apertures with trapezoidal walls and rounded corners may offer better paste release.

IMPORTANT NOTICE

Texas Instruments Incorporated (TI) reserves the right to make corrections, enhancements, improvements and other changes to its semiconductor products and services per JESD46, latest issue, and to discontinue any product or service per JESD48, latest issue. Buyers should obtain the latest relevant information before placing orders and should verify that such information is current and complete.

TI's published terms of sale for semiconductor products (<http://www.ti.com/sc/docs/stdterms.htm>) apply to the sale of packaged integrated circuit products that TI has qualified and released to market. Additional terms may apply to the use or sale of other types of TI products and services.

Reproduction of significant portions of TI information in TI data sheets is permissible only if reproduction is without alteration and is accompanied by all associated warranties, conditions, limitations, and notices. TI is not responsible or liable for such reproduced documentation. Information of third parties may be subject to additional restrictions. Resale of TI products or services with statements different from or beyond the parameters stated by TI for that product or service voids all express and any implied warranties for the associated TI product or service and is an unfair and deceptive business practice. TI is not responsible or liable for any such statements.

Buyers and others who are developing systems that incorporate TI products (collectively, "Designers") understand and agree that Designers remain responsible for using their independent analysis, evaluation and judgment in designing their applications and that Designers have full and exclusive responsibility to assure the safety of Designers' applications and compliance of their applications (and of all TI products used in or for Designers' applications) with all applicable regulations, laws and other applicable requirements. Designer represents that, with respect to their applications, Designer has all the necessary expertise to create and implement safeguards that (1) anticipate dangerous consequences of failures, (2) monitor failures and their consequences, and (3) lessen the likelihood of failures that might cause harm and take appropriate actions. Designer agrees that prior to using or distributing any applications that include TI products, Designer will thoroughly test such applications and the functionality of such TI products as used in such applications.

TI's provision of technical, application or other design advice, quality characterization, reliability data or other services or information, including, but not limited to, reference designs and materials relating to evaluation modules, (collectively, "TI Resources") are intended to assist designers who are developing applications that incorporate TI products; by downloading, accessing or using TI Resources in any way, Designer (individually or, if Designer is acting on behalf of a company, Designer's company) agrees to use any particular TI Resource solely for this purpose and subject to the terms of this Notice.

TI's provision of TI Resources does not expand or otherwise alter TI's applicable published warranties or warranty disclaimers for TI products, and no additional obligations or liabilities arise from TI providing such TI Resources. TI reserves the right to make corrections, enhancements, improvements and other changes to its TI Resources. TI has not conducted any testing other than that specifically described in the published documentation for a particular TI Resource.

Designer is authorized to use, copy and modify any individual TI Resource only in connection with the development of applications that include the TI product(s) identified in such TI Resource. NO OTHER LICENSE, EXPRESS OR IMPLIED, BY ESTOPPEL OR OTHERWISE TO ANY OTHER TI INTELLECTUAL PROPERTY RIGHT, AND NO LICENSE TO ANY TECHNOLOGY OR INTELLECTUAL PROPERTY RIGHT OF TI OR ANY THIRD PARTY IS GRANTED HEREIN, including but not limited to any patent right, copyright, mask work right, or other intellectual property right relating to any combination, machine, or process in which TI products or services are used. Information regarding or referencing third-party products or services does not constitute a license to use such products or services, or a warranty or endorsement thereof. Use of TI Resources may require a license from a third party under the patents or other intellectual property of the third party, or a license from TI under the patents or other intellectual property of TI.

TI RESOURCES ARE PROVIDED "AS IS" AND WITH ALL FAULTS. TI DISCLAIMS ALL OTHER WARRANTIES OR REPRESENTATIONS, EXPRESS OR IMPLIED, REGARDING RESOURCES OR USE THEREOF, INCLUDING BUT NOT LIMITED TO ACCURACY OR COMPLETENESS, TITLE, ANY EPIDEMIC FAILURE WARRANTY AND ANY IMPLIED WARRANTIES OF MERCHANTABILITY, FITNESS FOR A PARTICULAR PURPOSE, AND NON-INFRINGEMENT OF ANY THIRD PARTY INTELLECTUAL PROPERTY RIGHTS. TI SHALL NOT BE LIABLE FOR AND SHALL NOT DEFEND OR INDEMNIFY DESIGNER AGAINST ANY CLAIM, INCLUDING BUT NOT LIMITED TO ANY INFRINGEMENT CLAIM THAT RELATES TO OR IS BASED ON ANY COMBINATION OF PRODUCTS EVEN IF DESCRIBED IN TI RESOURCES OR OTHERWISE. IN NO EVENT SHALL TI BE LIABLE FOR ANY ACTUAL, DIRECT, SPECIAL, COLLATERAL, INDIRECT, PUNITIVE, INCIDENTAL, CONSEQUENTIAL OR EXEMPLARY DAMAGES IN CONNECTION WITH OR ARISING OUT OF TI RESOURCES OR USE THEREOF, AND REGARDLESS OF WHETHER TI HAS BEEN ADVISED OF THE POSSIBILITY OF SUCH DAMAGES.

Unless TI has explicitly designated an individual product as meeting the requirements of a particular industry standard (e.g., ISO/TS 16949 and ISO 26262), TI is not responsible for any failure to meet such industry standard requirements.

Where TI specifically promotes products as facilitating functional safety or as compliant with industry functional safety standards, such products are intended to help enable customers to design and create their own applications that meet applicable functional safety standards and requirements. Using products in an application does not by itself establish any safety features in the application. Designers must ensure compliance with safety-related requirements and standards applicable to their applications. Designer may not use any TI products in life-critical medical equipment unless authorized officers of the parties have executed a special contract specifically governing such use. Life-critical medical equipment is medical equipment where failure of such equipment would cause serious bodily injury or death (e.g., life support, pacemakers, defibrillators, heart pumps, neurostimulators, and implantables). Such equipment includes, without limitation, all medical devices identified by the U.S. Food and Drug Administration as Class III devices and equivalent classifications outside the U.S.

TI may expressly designate certain products as completing a particular qualification (e.g., Q100, Military Grade, or Enhanced Product). Designers agree that it has the necessary expertise to select the product with the appropriate qualification designation for their applications and that proper product selection is at Designers' own risk. Designers are solely responsible for compliance with all legal and regulatory requirements in connection with such selection.

Designer will fully indemnify TI and its representatives against any damages, costs, losses, and/or liabilities arising out of Designer's non-compliance with the terms and provisions of this Notice.

Looking for pricing, stock, or lifecycle information?

Click below to explore more details on WIN SOURCE:

 [View TPD4S214YFFR](#) on WIN SOURCE

 [Texas Instruments](#) Information

Optimize Your Supply Chain with WIN SOURCE Solutions

-  Global Sourcing Solution
-  Obsolete Management
-  Cost Control Management
-  Shortage Management
-  Alternative Solution
-  Excess Inventory Management