



**THE DATASHEET OF
TPD4S012DRYR**



TPD4S012 4-Channel ESD Solution for USB-HS/USB OTG/USB Charger Interface

1 Features

- Integrated ESD Clamps on all Pins
- USB Signal Pins (D+, D-, ID)
 - 0.8-pF Line Capacitance
- Supports Data Rates in Excess of 480 Mbps
- IEC 61000-4-2 ESD Protection (Level 4 Contact)
 - ±10-kV IEC 61000-4-2 Contact Discharge
- IEC 61000-4-5 Surge
 - 3 Amps Peak Pulse Current

2 Applications

- Cellular Phones
- Digital Cameras
- Global Positioning Systems (GPS)
- Portable Digital Assistants (PDA)
- Portable Computers

3 Description

The TPD4S012 is a four-channel Transient Voltage Suppressor (TVS) based Electrostatic Discharge (ESD) protection diode array for USB chargers and USB On-The-Go (OTG) interfaces.

The TPD4S012 provides IEC 61000-4-2 system level ESD Protection featuring 15 V tolerance on the V_{BUS} line. The device is ideal for providing circuit protection for USB charger and OTG applications due to its high-voltage tolerance at the V_{BUS} line and small flow-through package.

Device Information⁽¹⁾

PART NUMBER	PACKAGE	BODY SIZE (NOM)
TPD4S012	SON (6)	1.45 mm x 1.00 mm

(1) For all available packages, see the orderable addendum at the end of the datasheet.

Typical Application Schematic

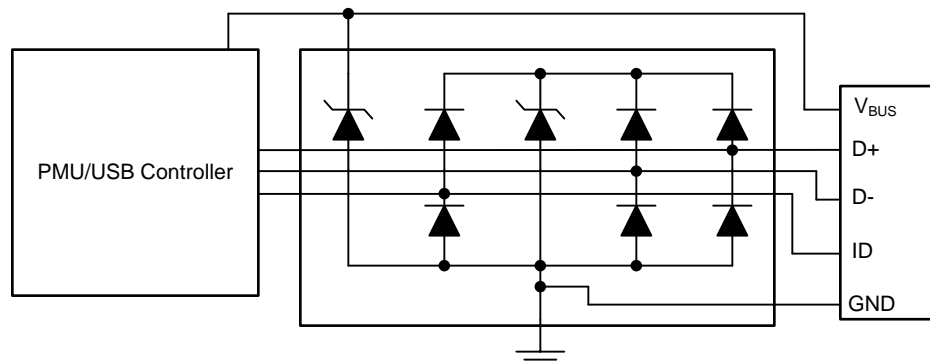

Table of Contents

1 Features	1	7.3 Feature Description	8
2 Applications	1	7.4 Device Functional Modes.....	9
3 Description	1	8 Applications and Implementation	10
4 Revision History	2	8.1 Application Information.....	10
5 Pin Configurations and Functions	3	8.2 Typical Application	10
6 Specifications	4	9 Power Supply Recommendations	12
6.1 Absolute Maximum Ratings	4	10 Layout	12
6.2 Handling Ratings.....	4	10.1 Layout Guidelines	12
6.3 Recommended Operating Conditions.....	4	10.2 Layout Example	12
6.4 Thermal Information	4	11 Device and Documentation Support	13
6.5 Electrical Characteristics.....	5	11.1 Trademarks	13
6.6 Typical Characteristics.....	6	11.2 Electrostatic Discharge Caution.....	13
7 Detailed Description	8	11.3 Glossary	13
7.1 Overview	8	12 Mechanical, Packaging, and Orderable Information	13
7.2 Functional Block Diagram	8		

4 Revision History

Changes from Revision A (November 2009) to Revision B	Page
<ul style="list-style-type: none"> Added <i>Handling Rating</i> table, <i>Feature Description</i> section, <i>Device Functional Modes</i>, <i>Application and Implementation</i> section, <i>Power Supply Recommendations</i> section, <i>Layout</i> section, <i>Device and Documentation Support</i> section, and <i>Mechanical, Packaging, and Orderable Information</i> section 	1

5 Pin Configurations and Functions

DRY PACKAGE (TOP VIEW)

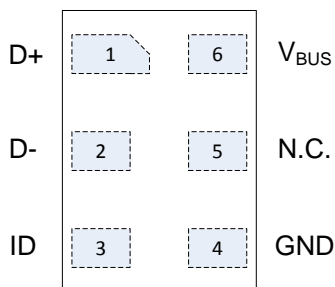

N.C. – Not internally connected

D+, D-, and ID pins are exact equivalent ESD clamp circuits. Any of these pins can be connected to any other D+, D-, or ID pin if it becomes easier to route the traces from the USB connector.

Pin Functions

PIN		TYPE	DESCRIPTION
DRY PIN NO.	NAME		
1	D+	ESD clamp	Provides ESD protection to the high-speed differential data lines
2	D-	ESD clamp	Provides ESD protection to the high-speed differential data lines
3	ID	ESD clamp	Provides ESD protection to the high-speed differential data lines
4	GND	PWR	Ground
5	N.C.	–	Not internally connected
6	V_{BUS}	ESD clamp	ESD clamp for high-voltage tolerant V_{BUS} line(s)

6 Specifications

6.1 Absolute Maximum Ratings

Over operating free-air temperature range (unless otherwise noted)

PARAMETER		MIN	MAX	UNIT
V_{BUS} voltage tolerance	V_{BUS} pin	-0.3	20	V
IO voltage tolerance	D+, D-, ID pins	-0.3	6	V
T_A Operating free-air temperature range		-40	85	°C
IEC 61000-4-2 Contact Discharge	D+, D-, ID		±10	kV
	V_{BUS} pin		±10	kV
IEC 61000-4-2 Air-Gap Discharge	D+, D-, ID		±10	kV
	V_{BUS} pin		±9	kV
IEC 61000-4-5 Surge ($t_p = 8/20 \mu s$)	Peak pulse Power (All pins)		60	W
	Peak pulse current (All Pins)		3	A

6.2 Handling Ratings

		MIN	MAX	UNIT	
T_{stg}	Storage temperature range	-65	125	°C	
$V_{(ESD)}$	Electrostatic discharge	Human body model (HBM), per ANSI/ESDA/JEDEC JS-001, all pins ⁽¹⁾	-2.5	2.5	kV
		Charged device model (CDM), per JEDEC specification JESD22-C101, all pins ⁽²⁾	-1	1	

(1) JEDEC document JEP155 states that 500-V HBM allows safe manufacturing with a standard ESD control process.

(2) JEDEC document JEP157 states that 250-V CDM allows safe manufacturing with a standard ESD control process.

6.3 Recommended Operating Conditions

over operating free-air temperature range (unless otherwise noted)

PARAMETER		MIN	MAX	UNIT
T_A Operating free-air Temperature Range		-40	85	°C
Operating Voltage	V_{BUS} Pin	0	15	V
	D+, D-, ID Pins	0	5.5	

6.4 Thermal Information

THERMAL METRIC ⁽¹⁾		TPD4S012	UNIT
		DRY	
		6 PINS	
$R_{\theta JA}$	Junction-to-ambient thermal resistance	461.3	°C/W
$R_{\theta JC(top)}$	Junction-to-case (top) thermal resistance	219.6	
$R_{\theta JB}$	Junction-to-board thermal resistance	343.7	
Ψ_{JT}	Junction-to-top characterization parameter	162.5	
Ψ_{JB}	Junction-to-board characterization parameter	343.7	

(1) For more information about traditional and new thermal metrics, see the *IC Package Thermal Metrics* application report, [SPRA953](#).

6.5 Electrical Characteristics

over operating free-air temperature range (unless otherwise noted)

PARAMETER		TEST CONDITIONS		MIN	TYP	MAX	UNIT
$I_{V_{BUS}}$	V_{BUS} operating current	$V_{BUS} = 19\text{ V}$	D+, D–, ID pins open		0.1	0.5	μA
I_{IO}	IO port current	$V_{IO} = 2.5\text{ V}$, $V_{BUS} = 5\text{ V}$	D+, D–, ID pins		0.1	0.5	μA
V_D	Diode forward voltage	$I_{IO} = 8\text{ mA}$	D+, D–, ID pins (lower clamp diode)	0.6	0.8	0.95	V
$C_{V_{BUS}}$	V_{BUS} pin capacitance	$V_{BUS} = 5\text{ V}$			11	15	pF
C_{IO}	IO capacitance	$V_{IO} = 2.5\text{ V}$	D+, D–, ID pins		0.8	1	pF
R_{DYN}	Dynamic resistance	$I_{IO} = 1.5\text{ A}$	D+, D–, ID, and V_{BUS} pins, including central clamp diode during positive ESD pulse		1.2		Ω
		$I_{IO} = 1\text{ A}$	D+, D–, ID, and V_{BUS} pins, including central clamp diode during negative ESD pulse		1		
V_{BR}	Breakdown voltage	$I_{IO} = 1\text{ mA}$	D+, D–, ID pins	6	9		V
			V_{BUS} pin(s)	20	24		

6.6 Typical Characteristics

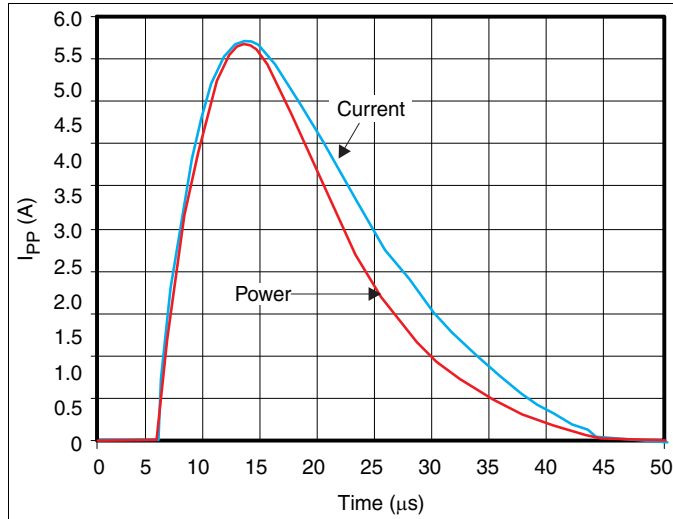

Figure 1. Peak Pulse Power Waveform at the D+, D-, or ID Pin

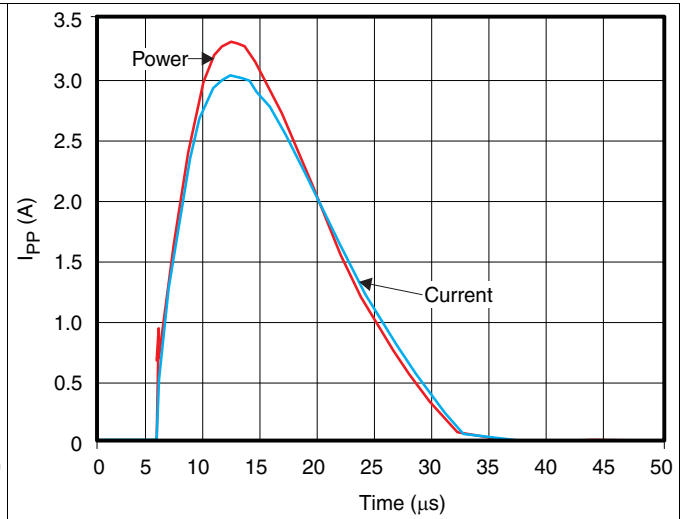

Figure 2. Peak Pulse Power Waveform at the V_{BUS} Pin

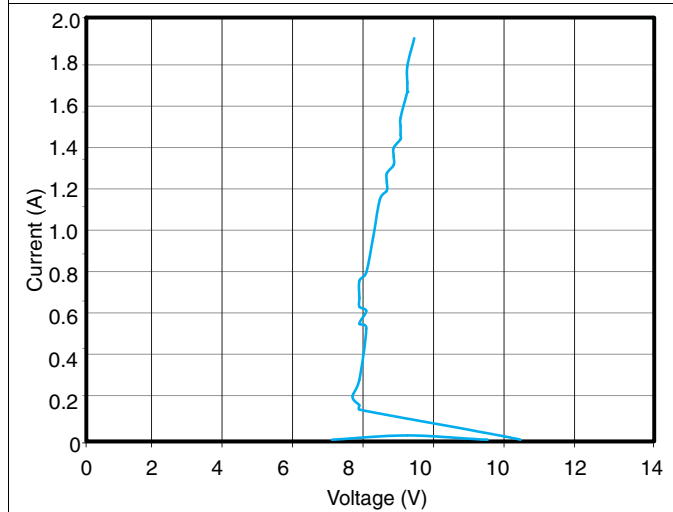

Figure 3. D+, D-, or ID Clamp Voltage Under ESD Event

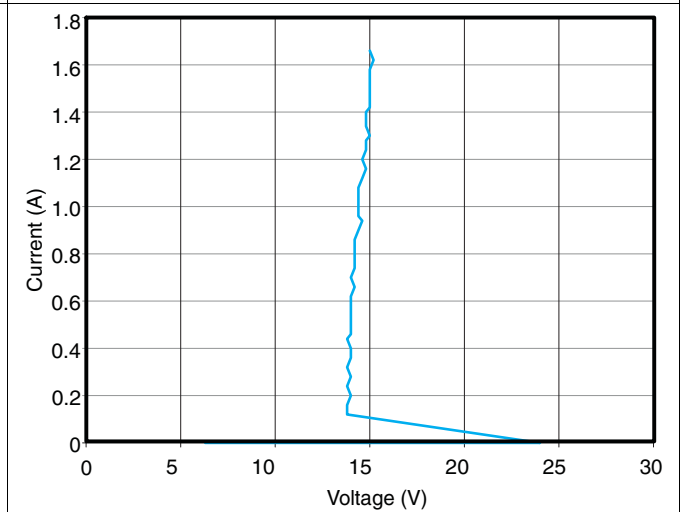

Figure 4. V_{BUS} Clamp Voltage Under ESD Event

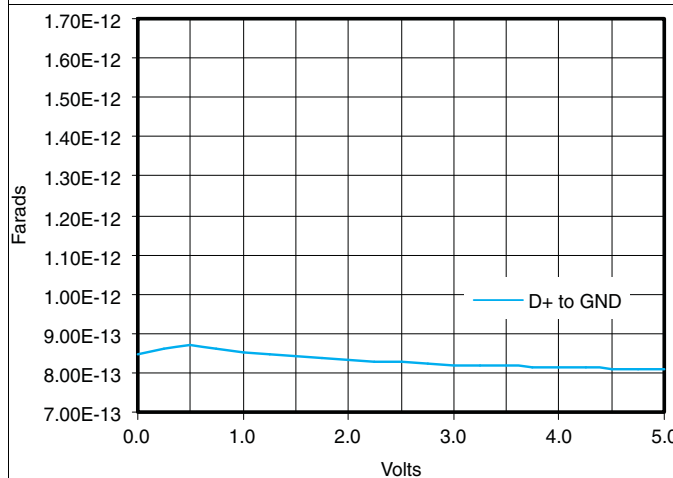

Figure 5. D+, D-, or ID Capacitance, T_A = 27°C

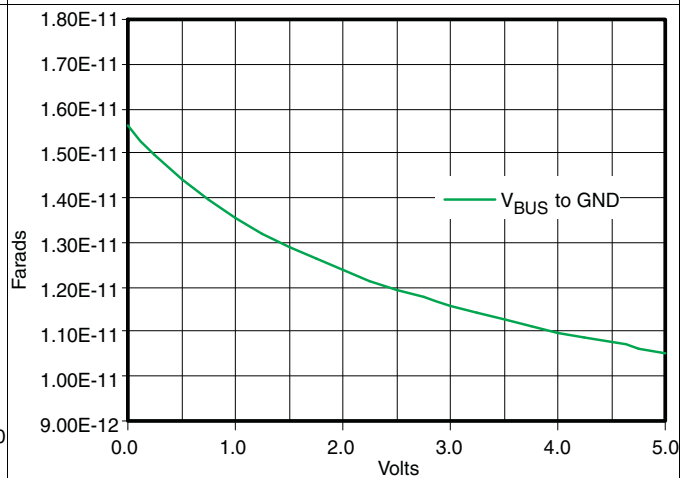

Figure 6. V_{BUS} Capacitance, T_A = 27°C

Typical Characteristics (continued)

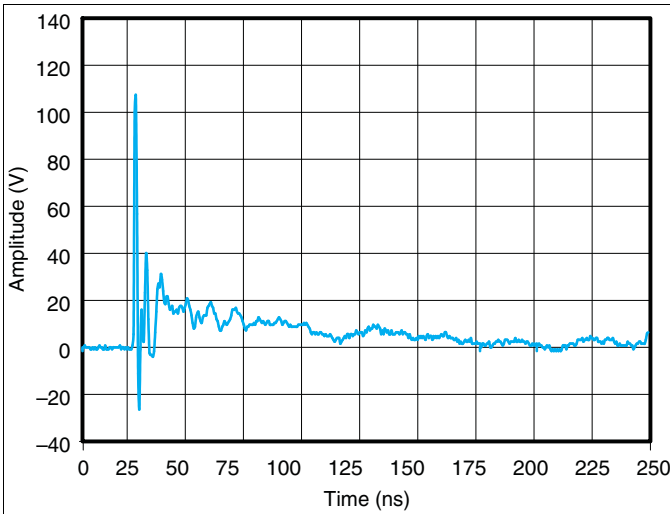

Figure 7. IEC Clamping Waveform, 8 kV Contact, D+, 25 ns/div

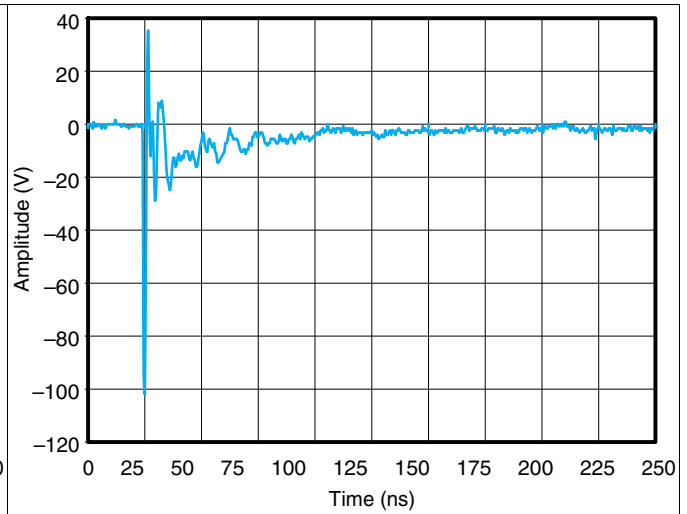

Figure 8. IEC Clamping Waveform, -8 kV Contact, D+, 25 ns/div

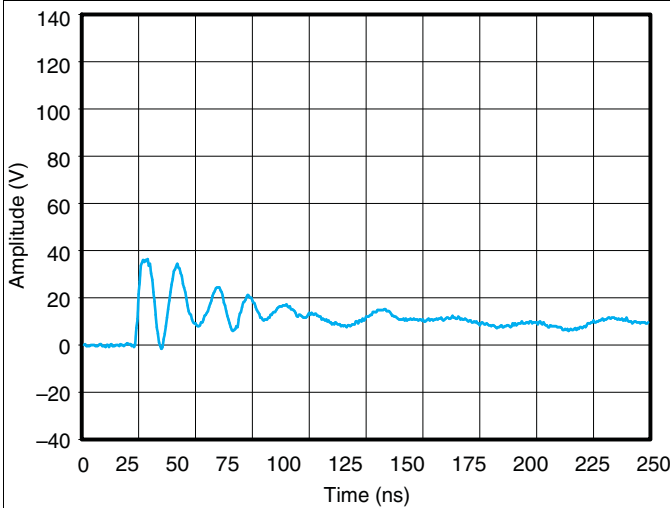

Figure 9. V_{BUS} IEC Clamping Waveform, 8 kV Contact, 25 ns/div

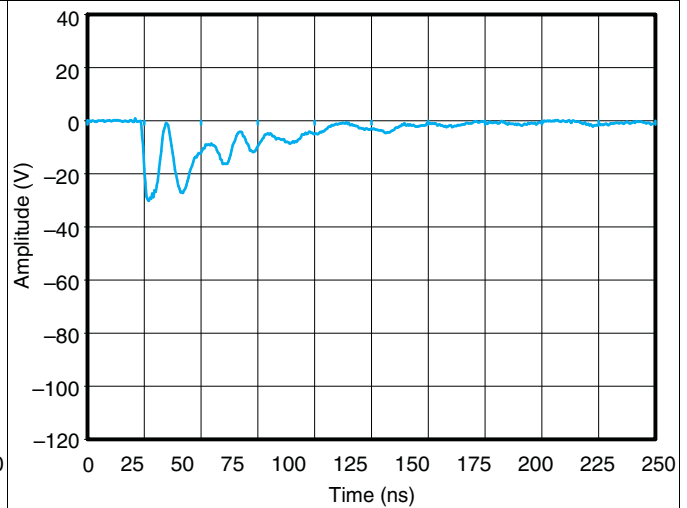

Figure 10. V_{BUS} IEC Clamping Waveform, -8 kV Contact, 25 ns/div

7 Detailed Description

7.1 Overview

The TPD4S012 is a four-channel Transient Voltage Suppressor (TVS) based Electrostatic Discharge (ESD) protection diode array for USB chargers and USB On-The-Go (OTG) interfaces.

The TPD4S012 provides IEC 61000-4-2 system level ESD Protection featuring 15 V tolerance on the V_{BUS} line. The device is ideal for providing circuit protection for USB charger and OTG applications due to its high-voltage tolerance at the V_{BUS} line and small flow-through package.

7.2 Functional Block Diagram

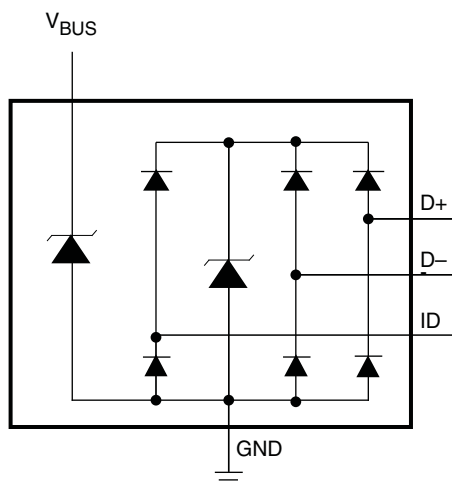

7.3 Feature Description

7.3.1 Integrated ESD Clamps

Integrated ESD Clamps on the D+, D-, V_{BUS} , and ID pins provide single-chip ESD protection for USB High Speed, USB-OTG, and USB charger interfaces.

7.3.2 USB Signal Pins

D+, D- and ID USB Signal pins have low capacitance (0.8 pF Typ).

7.3.3 V_{BUS} Line

The V_{BUS} line has a 11 pF (Typ) capacitance.

7.3.4 Supports Data Rates in Excess of 480 Mbps

The low capacitance (0.8 pF Typ) of the data lines supports speeds in excess of 480 Mbps.

7.3.5 IEC 61000-4-2 (Level 4 Contact)

IEC 61000-4-2 (Level 4 contact) system level ESD compliance measured at the D+, D- and ID pins is rated for ± 10 kV contact and air-gap discharge.

7.3.6 IEC 61000-4-5 Surge

IEC 61000-4-5 system level surge compliance measured at D+, D-, ID, and V_{BUS} pins rated to 3 A of peak pulse current.

7.4 Device Functional Modes

The TPD4S012 is a passive integrated circuit that triggers when voltages are above V_{BR} or below the lower diode's V_f . During ESD events, voltages as high as ± 10 kV (contact) can be directed to ground via the internal diode network. Once the voltages on the protected line fall below the trigger levels of TPD4S012 (usually within 10's of nano-seconds), the device reverts to passive.

8 Applications and Implementation

8.1 Application Information

The TPD4S012 is a four-channel Transient Voltage Suppressor (TVS) based Electrostatic Discharge (ESD) protection diode array for USB chargers and USB On-The-Go (OTG) interfaces.

The TPD4S012 provides IEC 61000-4-2 system level ESD Protection featuring 15 V tolerance on the V_{BUS} line. The device is ideal for providing circuit protection for USB charger and OTG applications due to its high-voltage tolerance at the V_{BUS} line and small flow-through package.

8.2 Typical Application

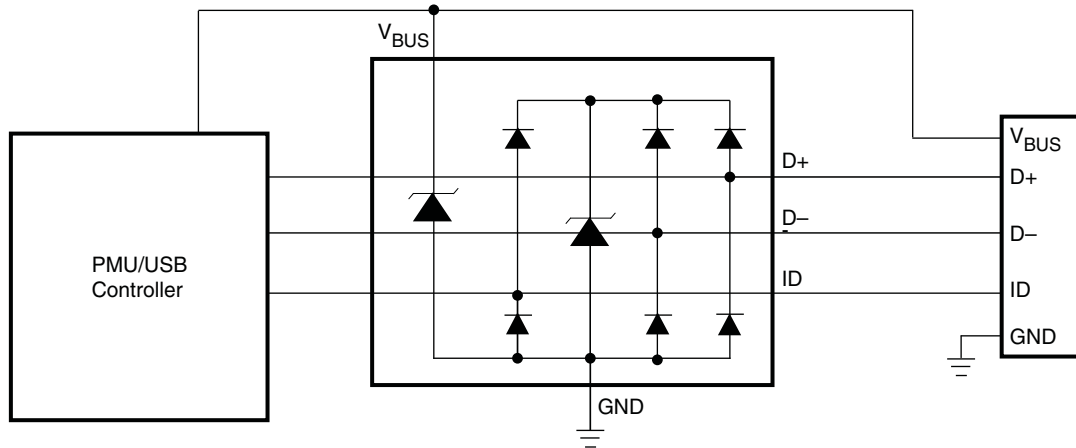

If the ID pin is not used, it can be left floating.

Figure 11. Typical Application Schematic

8.2.1 Design Requirements

For this design example, a single TPD4S012 is used to protect all pins of a micro/mini USB connector.

Given the USB application, the following parameters are known.

DESIGN PARAMETER	VALUE
Signal range on D+, D-, and ID	0 V to 5 V
Signal range on V_{BUS}	0 V to 5 V
Operating Frequency	240 MHz

8.2.2 Detailed Design Procedure

To begin the design process, some parameters must be decided upon; the designer needs to know the following:

- Signal range on all the protected lines
- Operating frequency

8.2.2.1 Signal Range on D+, D-, ID and V_{BUS} pins

The TPD4S012 has 3 pins which support 0 to 5.5 V signals, these are suited for the D+, D-, and ID pins. The V_{BUS} pin is suitable for the VBUS line, and has the benefit of being tolerant of voltages up to 16 V

8.2.2.2 Operating Frequency

The 0.8 pF (Typ) of the TPD4S012 support data rates in excess of 480 Mbps.

8.2.3 Application Curve

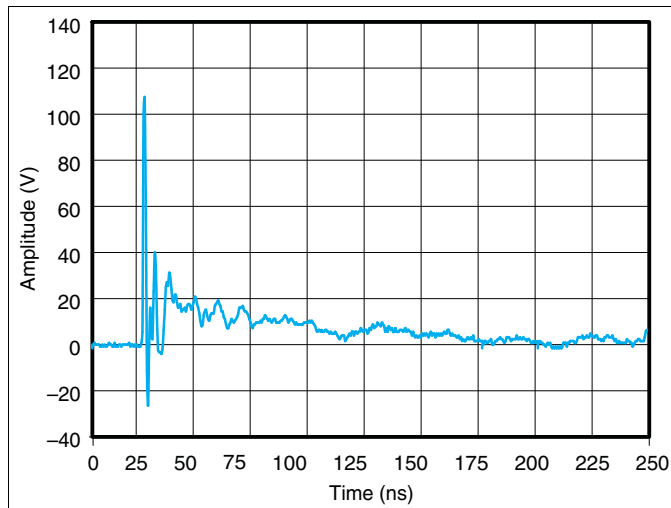

Figure 12. IEC Clamping Waveform, 8 kV Contact, D+, 25 ns/div

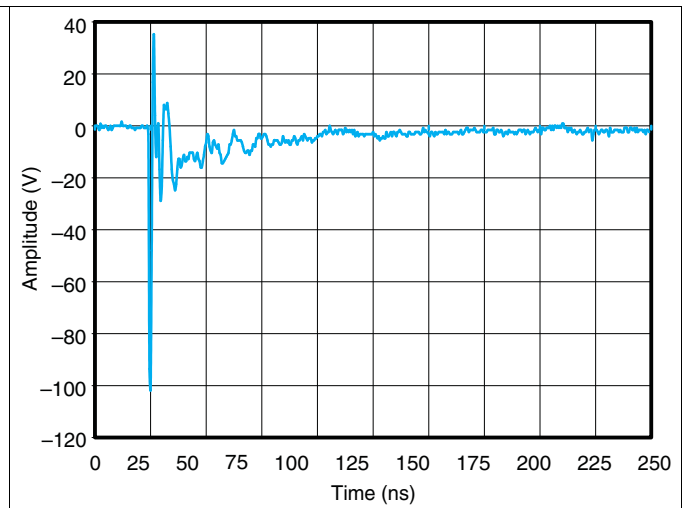

Figure 13. IEC Clamping Waveform, -8 kV Contact, D+, 25 ns/div

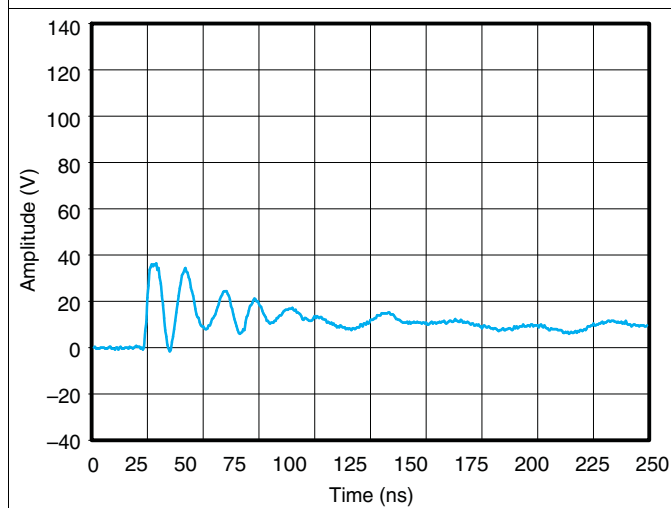

Figure 14. V_{BUS} IEC Clamping Waveform, 8 kV Contact, 25 ns/div

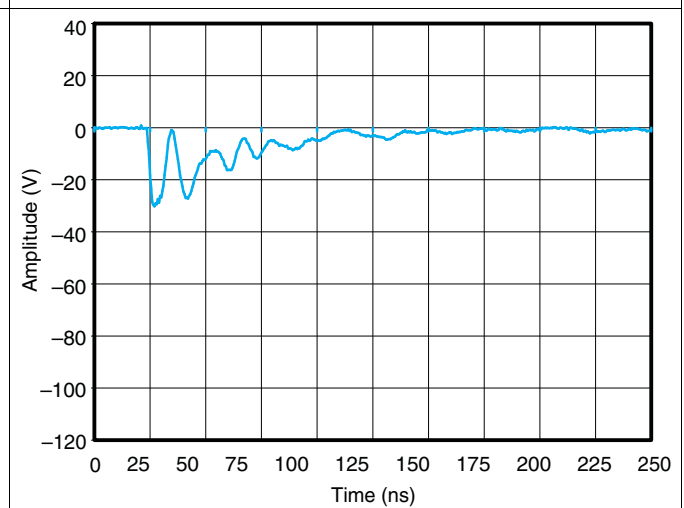

Figure 15. V_{BUS} IEC Clamping Waveform, -8 kV Contact, 25 ns/div

9 Power Supply Recommendations

This family of devices are passive ESD protection devices and there is no need to power them. Care should be taken to not violate the maximum voltage specification to ensure that the device functions properly. The V_{BUS} TVS diode can tolerate up to a 15 V signal. The D+, D–, and ID pins tolerate up to a 5.5 V signal.

10 Layout

10.1 Layout Guidelines

- The optimum placement is as close to the connector as possible.
 - EMI during an ESD event can couple from the trace being struck to other nearby unprotected traces, resulting in early system failures.
 - The PCB designer needs to minimize the possibility of EMI coupling by keeping any unprotected traces away from the protected traces which are between the TVS and the connector.
- Route the protected traces as straight as possible.
- Eliminate any sharp corners on the protected traces between the TVS and the connector by using rounded corners with the largest radii possible.
 - Electric fields tend to build up on corners, increasing EMI coupling.

10.2 Layout Example

This application is typical of a mobile USB platform with an ID pin in addition to the D+, D–, and V_{BUS} pins.

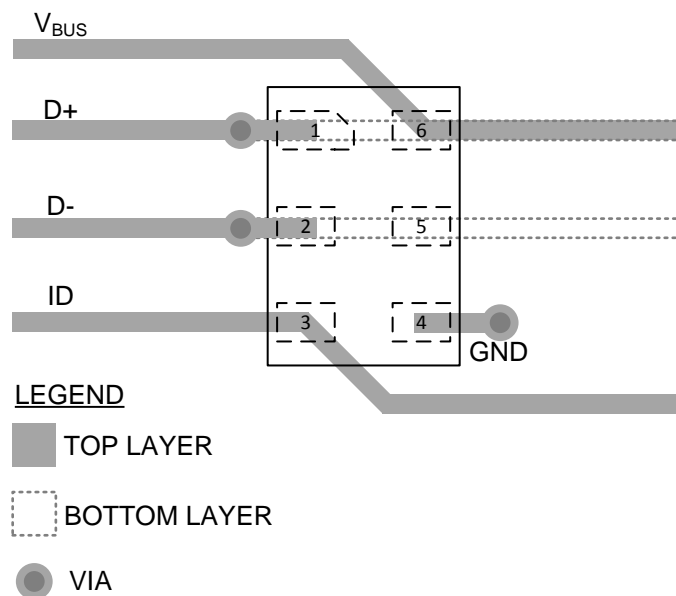

Figure 16. Using DRY Package

11 Device and Documentation Support

11.1 Trademarks

All trademarks are the property of their respective owners.

11.2 Electrostatic Discharge Caution



These devices have limited built-in ESD protection. The leads should be shorted together or the device placed in conductive foam during storage or handling to prevent electrostatic damage to the MOS gates.

11.3 Glossary

[SLYZ022](#) — *TI Glossary*.

This glossary lists and explains terms, acronyms, and definitions.

12 Mechanical, Packaging, and Orderable Information

The following pages include mechanical, packaging, and orderable information. This information is the most current data available for the designated devices. This data is subject to change without notice and revision of this document. For browser-based versions of this data sheet, refer to the left-hand navigation.

PACKAGING INFORMATION

Orderable Device	Status (1)	Package Type	Package Drawing	Pins	Package Qty	Eco Plan (2)	Lead finish/ Ball material (6)	MSL Peak Temp (3)	Op Temp (°C)	Device Marking (4/5)	Samples
TPD4S012DRYR	ACTIVE	SON	DRY	6	5000	RoHS & Green	NIPDAU	Level-1-260C-UNLIM	-40 to 85	3B	Samples

(1) The marketing status values are defined as follows:

ACTIVE: Product device recommended for new designs.

LIFEBUY: TI has announced that the device will be discontinued, and a lifetime-buy period is in effect.

NRND: Not recommended for new designs. Device is in production to support existing customers, but TI does not recommend using this part in a new design.

PREVIEW: Device has been announced but is not in production. Samples may or may not be available.

OBSELETE: TI has discontinued the production of the device.

(2) **RoHS:** TI defines "RoHS" to mean semiconductor products that are compliant with the current EU RoHS requirements for all 10 RoHS substances, including the requirement that RoHS substance do not exceed 0.1% by weight in homogeneous materials. Where designed to be soldered at high temperatures, "RoHS" products are suitable for use in specified lead-free processes. TI may reference these types of products as "Pb-Free".

RoHS Exempt: TI defines "RoHS Exempt" to mean products that contain lead but are compliant with EU RoHS pursuant to a specific EU RoHS exemption.

Green: TI defines "Green" to mean the content of Chlorine (Cl) and Bromine (Br) based flame retardants meet JS709B low halogen requirements of <=1000ppm threshold. Antimony trioxide based flame retardants must also meet the <=1000ppm threshold requirement.

(3) MSL, Peak Temp. - The Moisture Sensitivity Level rating according to the JEDEC industry standard classifications, and peak solder temperature.

(4) There may be additional marking, which relates to the logo, the lot trace code information, or the environmental category on the device.

(5) Multiple Device Markings will be inside parentheses. Only one Device Marking contained in parentheses and separated by a "-" will appear on a device. If a line is indented then it is a continuation of the previous line and the two combined represent the entire Device Marking for that device.

(6) Lead finish/Ball material - Orderable Devices may have multiple material finish options. Finish options are separated by a vertical ruled line. Lead finish/Ball material values may wrap to two lines if the finish value exceeds the maximum column width.

Important Information and Disclaimer:The information provided on this page represents TI's knowledge and belief as of the date that it is provided. TI bases its knowledge and belief on information provided by third parties, and makes no representation or warranty as to the accuracy of such information. Efforts are underway to better integrate information from third parties. TI has taken and continues to take reasonable steps to provide representative and accurate information but may not have conducted destructive testing or chemical analysis on incoming materials and chemicals. TI and TI suppliers consider certain information to be proprietary, and thus CAS numbers and other limited information may not be available for release.

In no event shall TI's liability arising out of such information exceed the total purchase price of the TI part(s) at issue in this document sold by TI to Customer on an annual basis.

TAPE AND REEL INFORMATION

QUADRANT ASSIGNMENTS FOR PIN 1 ORIENTATION IN TAPE

*All dimensions are nominal

Device	Package Type	Package Drawing	Pins	SPQ	Reel Diameter (mm)	Reel Width W1 (mm)	A0 (mm)	B0 (mm)	K0 (mm)	P1 (mm)	W (mm)	Pin1 Quadrant
TPD4S012DRYR	SON	DRY	6	5000	180.0	9.5	1.2	1.65	0.7	4.0	8.0	Q1

TAPE AND REEL BOX DIMENSIONS



*All dimensions are nominal

Device	Package Type	Package Drawing	Pins	SPQ	Length (mm)	Width (mm)	Height (mm)
TPD4S012DRYR	SON	DRY	6	5000	189.0	185.0	36.0

GENERIC PACKAGE VIEW

DRY 6

USON - 0.6 mm max height

PLASTIC SMALL OUTLINE - NO LEAD



Images above are just a representation of the package family, actual package may vary.
Refer to the product data sheet for package details.

4207181/G

DRY0006A



PACKAGE OUTLINE

USON - 0.6 mm max height

PLASTIC SMALL OUTLINE - NO LEAD

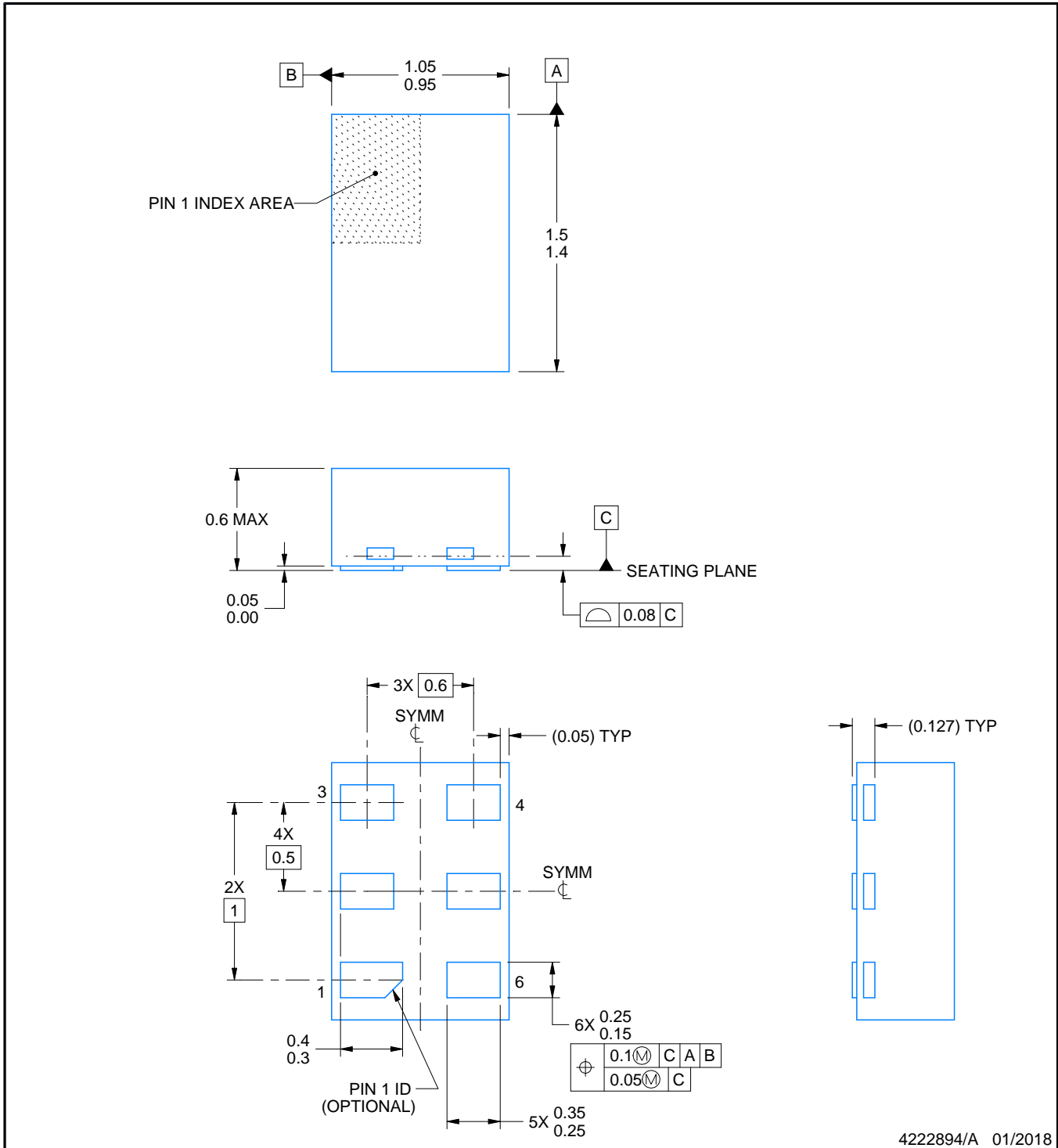

NOTES:

1. All linear dimensions are in millimeters. Any dimensions in parenthesis are for reference only. Dimensioning and tolerancing per ASME Y14.5M.
2. This drawing is subject to change without notice.

EXAMPLE BOARD LAYOUT

DRY0006A

USON - 0.6 mm max height

PLASTIC SMALL OUTLINE - NO LEAD

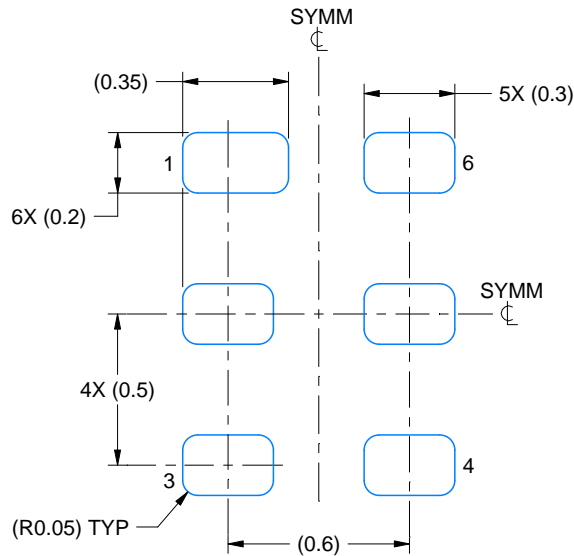

LAND PATTERN EXAMPLE
1:1 RATIO WITH PKG SOLDER PADS
EXPOSED METAL SHOWN
SCALE:40X

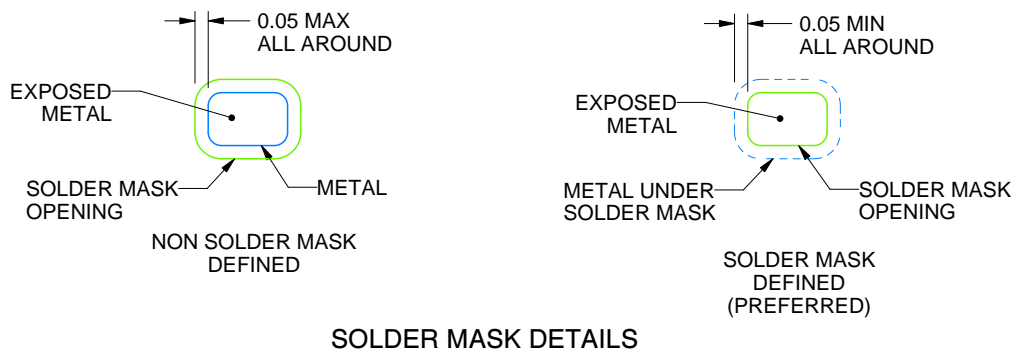

SOLDER MASK DETAILS

4222894/A 01/2018

NOTES: (continued)

3. For more information, see QFN/SON PCB application report in literature No. SLUA271 (www.ti.com/lit/slua271).

EXAMPLE STENCIL DESIGN

DRY0006A

USON - 0.6 mm max height

PLASTIC SMALL OUTLINE - NO LEAD

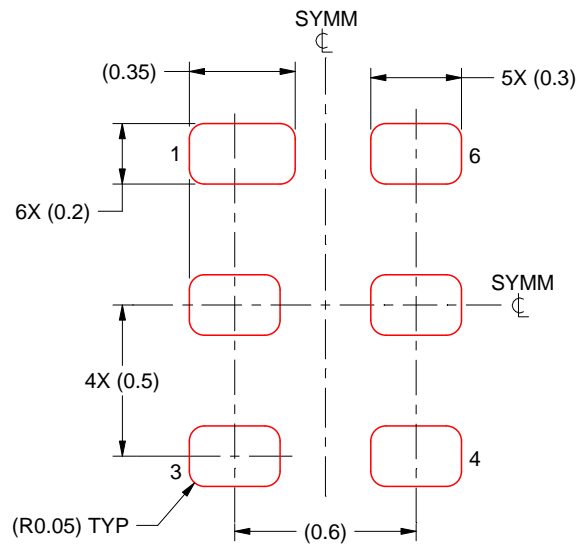

SOLDER PASTE EXAMPLE
BASED ON 0.075 - 0.1 mm THICK STENCIL
SCALE:40X

4222894/A 01/2018

NOTES: (continued)

4. Laser cutting apertures with trapezoidal walls and rounded corners may offer better paste release. IPC-7525 may have alternate design recommendations.

IMPORTANT NOTICE AND DISCLAIMER

TI PROVIDES TECHNICAL AND RELIABILITY DATA (INCLUDING DATA SHEETS), DESIGN RESOURCES (INCLUDING REFERENCE DESIGNS), APPLICATION OR OTHER DESIGN ADVICE, WEB TOOLS, SAFETY INFORMATION, AND OTHER RESOURCES "AS IS" AND WITH ALL FAULTS, AND DISCLAIMS ALL WARRANTIES, EXPRESS AND IMPLIED, INCLUDING WITHOUT LIMITATION ANY IMPLIED WARRANTIES OF MERCHANTABILITY, FITNESS FOR A PARTICULAR PURPOSE OR NON-INFRINGEMENT OF THIRD PARTY INTELLECTUAL PROPERTY RIGHTS.

These resources are intended for skilled developers designing with TI products. You are solely responsible for (1) selecting the appropriate TI products for your application, (2) designing, validating and testing your application, and (3) ensuring your application meets applicable standards, and any other safety, security, regulatory or other requirements.

These resources are subject to change without notice. TI grants you permission to use these resources only for development of an application that uses the TI products described in the resource. Other reproduction and display of these resources is prohibited. No license is granted to any other TI intellectual property right or to any third party intellectual property right. TI disclaims responsibility for, and you will fully indemnify TI and its representatives against, any claims, damages, costs, losses, and liabilities arising out of your use of these resources.

TI's products are provided subject to [TI's Terms of Sale](#) or other applicable terms available either on [ti.com](https://www.ti.com) or provided in conjunction with such TI products. TI's provision of these resources does not expand or otherwise alter TI's applicable warranties or warranty disclaimers for TI products.

TI objects to and rejects any additional or different terms you may have proposed.

Mailing Address: Texas Instruments, Post Office Box 655303, Dallas, Texas 75265
Copyright © 2023, Texas Instruments Incorporated

Looking for pricing, stock, or lifecycle information?

Click below to explore more details on WIN SOURCE:

 [View TPD4S012DRYR on WIN SOURCE](#)

 [Texas Instruments](#) Information

Optimize Your Supply Chain with WIN SOURCE Solutions

-  Global Sourcing Solution
-  Obsolete Management
-  Cost Control Management
-  Shortage Management
-  Alternative Solution
-  Excess Inventory Management