



**THE DATASHEET OF  
TPD4E004DRYR**



# TPD4E004 4-Channel ESD-Protection Array For High-Speed Data Interfaces

## 1 Features

- IEC 61000-4-2 ESD Protection
  - ±8-kV IEC 61000-4-2 Contact Discharge
  - ±12-kV IEC 61000-4-2 Air-Gap Discharge
- ANSI/ESDA/JEDEC JS-001
  - ±15-kV Human Body Model (HBM)
- Low 1.6-pF Input Capacitance
- 0.9-V to 5.5-V Supply Voltage Range
- 4-Channel Device
- Space-Saving SON (DRY) Package

## 2 Applications

- USB
- Ethernet
- FireWire
- Videos
- Cell Phones
- SVGA Video Connections
- Glucose Meters

## 3 Description

The TPD4E004 is a low-capacitance transient voltage suppression (TVS) device. TPD4E004 is designed to protect sensitive electronics attached to communication lines from electrostatic discharge (ESD). Each of the four channels consists of a pair of diodes that steer ESD current pulses to  $V_{CC}$  or GND. The TPD4E004 protects against ESD pulses up to ±15-kV Human-Body Model (HBM) and, as specified in IEC 61000-4-2, ±8-kV contact discharge and ±12-kV air-gap Discharge. This device has 1.6-pF of capacitance per channel, making it ideal for use in high-speed data IO interfaces.

The TPD4E004 is a quad-ESD structure designed for USB, ethernet, and other high-speed applications.

### Device Information<sup>(1)</sup>

PART NUMBER	PACKAGE	BODY SIZE (NOM)
TPD4E004	SON (6)	1.45 mm x 1.00 mm

(1) For all available packages, see the orderable addendum at the end of the data sheet.

### Application Schematic

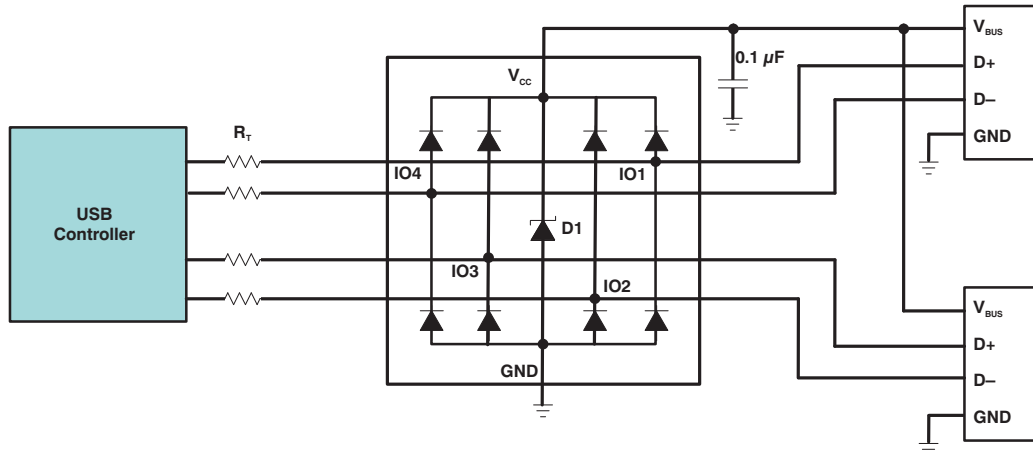

## Table of Contents

<b>1 Features</b> .....	<b>1</b>	7.4 Device Functional Modes.....	<b>7</b>
<b>2 Applications</b> .....	<b>1</b>	<b>8 Application and Implementation</b> .....	<b>8</b>
<b>3 Description</b> .....	<b>1</b>	8.1 Application Information.....	<b>8</b>
<b>4 Revision History</b> .....	<b>2</b>	8.2 Typical Application .....	<b>8</b>
<b>5 Pin Configuration and Functions</b> .....	<b>3</b>	<b>9 Power Supply Recommendations</b> .....	<b>9</b>
<b>6 Specifications</b> .....	<b>4</b>	<b>10 Layout</b> .....	<b>10</b>
6.1 Absolute Maximum Ratings .....	4	10.1 Layout Guidelines .....	10
6.2 ESD Ratings.....	4	10.2 Layout Example .....	10
6.3 Recommended Operating Conditions.....	4	<b>11 Device and Documentation Support</b> .....	<b>11</b>
6.4 Thermal Information .....	4	11.1 Documentation Support .....	11
6.5 Electrical Characteristics.....	5	11.2 Community Resources.....	11
6.6 Typical Characteristics.....	6	11.3 Trademarks .....	11
<b>7 Detailed Description</b> .....	<b>7</b>	11.4 Electrostatic Discharge Caution.....	11
7.1 Overview .....	7	11.5 Glossary .....	11
7.2 Functional Block Diagram .....	7	<b>12 Mechanical, Packaging, and Orderable</b>	
7.3 Feature Description.....	7	<b>Information</b> .....	<b>11</b>

## 4 Revision History

NOTE: Page numbers for previous revisions may differ from page numbers in the current version.

<b>Changes from Revision A (February 2008) to Revision B</b>	<b>Page</b>
• Added <i>Device Information</i> table, <i>ESD Ratings</i> table, <i>Feature Description</i> section, <i>Device Functional Modes</i> , <i>Application and Implementation</i> section, <i>Power Supply Recommendations</i> section, <i>Layout</i> section, <i>Device and Documentation Support</i> section, and <i>Mechanical, Packaging, and Orderable Information</i> section. ....	<b>1</b>
• Deleted the ordering information .....	<b>1</b>

## 5 Pin Configuration and Functions

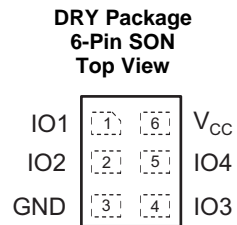

### Pin Functions

PIN		I/O	DESCRIPTION
NO.	NAME		
1	IO1	IO	ESD-protected channel
2	IO2	IO	ESD-protected channel
3	GND	GND	Ground
4	IO3	IO	ESD-protected channel
5	IO4	IO	ESD-protected channel
6	V <sub>CC</sub>	PWR	Power-supply input

## 6 Specifications

### 6.1 Absolute Maximum Ratings

over operating free-air temperature range (unless otherwise noted) <sup>(1)</sup>

		MIN	MAX	UNIT
V <sub>CC</sub>	Supply voltage	-0.3	5.5	V
V <sub>IO</sub>	Input/output voltage	-0.3	V <sub>CC</sub> + 0.3	V
	Bump temperature (soldering)	Infrared (15 s)	220	°C
		Vapor phase (60 s)	215	
	Lead temperature (soldering, 10 s)		300	°C
T <sub>J</sub>	Junction temperature		150	°C
T <sub>stg</sub>	Storage temperature	-65	150	°C

- (1) Stresses beyond those listed under *Absolute Maximum Ratings* may cause permanent damage to the device. These are stress ratings only, which do not imply functional operation of the device at these or any other conditions beyond those indicated under *Recommended Operating Conditions*. Exposure to absolute-maximum-rated conditions for extended periods may affect device reliability.

### 6.2 ESD Ratings

			VALUE	UNIT	
V <sub>(ESD)</sub>	Electrostatic discharge	Human-body model (HBM), per ANSI/ESDA/JEDEC JS-001	±15000	V	
		IEC 61000-4-2	Contact Discharge		±8000
			Air-Gap Discharge		±12000

### 6.3 Recommended Operating Conditions

over operating free-air temperature range (unless otherwise noted)

		MIN	MAX	UNIT
T <sub>A</sub>	Operating free-air temperature	-40	85	°C
V <sub>CC</sub>	Operating voltage for pin V <sub>CC</sub>	0.9	5.5	V
V <sub>IO</sub>	Operating voltage for pins IO1, IO2, IO3, and IO4	0	Minimum of: (5.8, V <sub>CC</sub> )	V

### 6.4 Thermal Information

THERMAL METRIC <sup>(1)</sup>		TPD4E004	UNIT
		DRY (SON)	
		6 PINS	
R <sub>θJA</sub>	Junction-to-ambient thermal resistance	414.8	°C/W
R <sub>θJC(top)</sub>	Junction-to-case (top) thermal resistance	258.6	°C/W
R <sub>θJB</sub>	Junction-to-board thermal resistance	251.6	°C/W
ψ <sub>JT</sub>	Junction-to-top characterization parameter	70.6	°C/W
ψ <sub>JB</sub>	Junction-to-board characterization parameter	248.2	°C/W
R <sub>θJC(bot)</sub>	Junction-to-case (bottom) thermal resistance	n/a	°C/W

- (1) For more information about traditional and new thermal metrics, see the *Semiconductor and IC Package Thermal Metrics* application report, [SPRA953](#).

## 6.5 Electrical Characteristics

$V_{CC} = 0.9\text{ V to }5.5\text{ V}$ ,  $T_A = T_{MIN}$  to  $T_{MAX}$  (unless otherwise noted)

PARAMETER		TEST CONDITIONS	MIN	TYP <sup>(1)</sup>	MAX	UNIT
$V_{CC}$	Supply voltage		0.9		5.5	V
$I_{CC}$	Supply current				500	nA
$V_F$	Diode forward voltage	$I_F = 1\text{ mA}$		0.8		V
$I_l$	Channel leakage current			$\pm 1$		nA
$V_{BR}$	Break-down voltage	$I_l = 10\text{ }\mu\text{A}$	6		8	V
$C_{I/O}$	Channel input capacitance	$V_{CC} = 5\text{ V}$ , Bias of $V_{CC}/2$ , $f = 10\text{ MHz}$		1.6	2	pF

(1) Typical values are at  $V_{CC} = 5\text{ V}$  and  $T_A = 25^\circ\text{C}$ .

## 6.6 Typical Characteristics

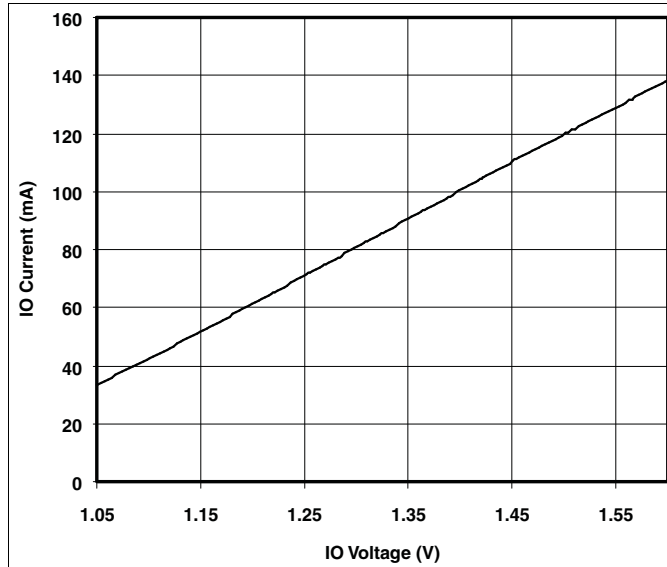

Figure 1. Forward Diode Voltage (Upper Clamp Diode)  
( $V_{CC} = 0\text{ V}$ , DC Sweep Across the IO Pin)

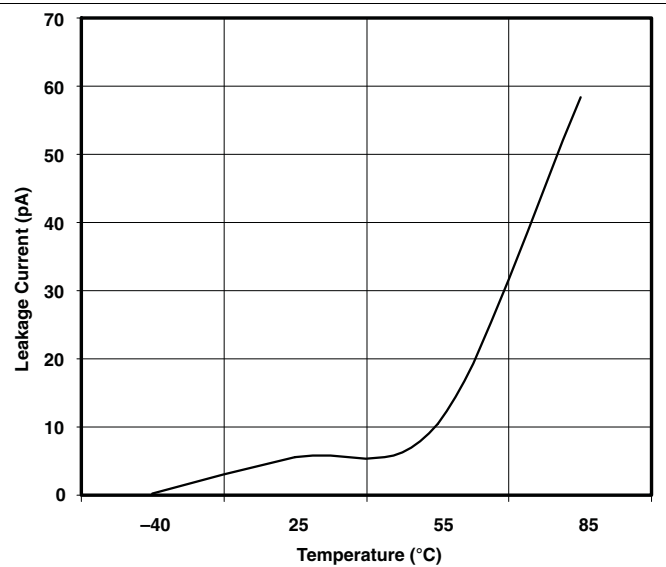

Figure 2. Leakage Current vs Temperature ( $V_{IO} = 2.5\text{ V}$ )

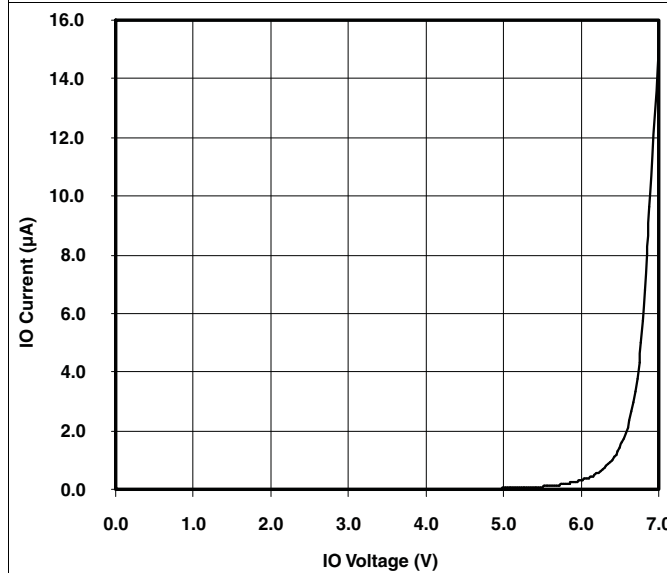

Figure 3. Reverse Diode Curve Current IO to Gnd  
( $V_{CC} = \text{Open}$ )

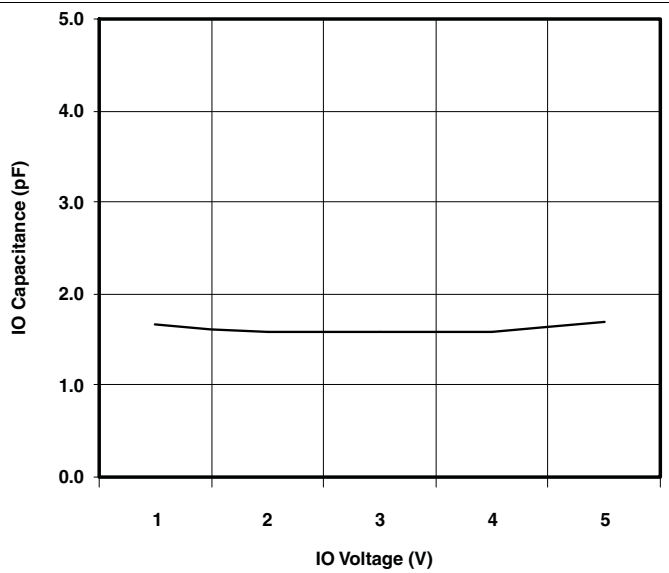

Figure 4. IO Capacitance vs Input Voltage  
( $V_{CC} = 5\text{ V}$ )

## 7 Detailed Description

### 7.1 Overview

The TPD4E004 is a four-channel TVS protection diode array. The TPD4E004 is rated to dissipate contact ESD strikes of  $\pm 8$ -kV contact and  $\pm 12$ -kV air-gap, meeting Level 4 as specified in the IEC 61000-4-2 international standard. This device has a 1.6-pF IO capacitance per channel, making it ideal for use in high-speed data IO interfaces.

### 7.2 Functional Block Diagram

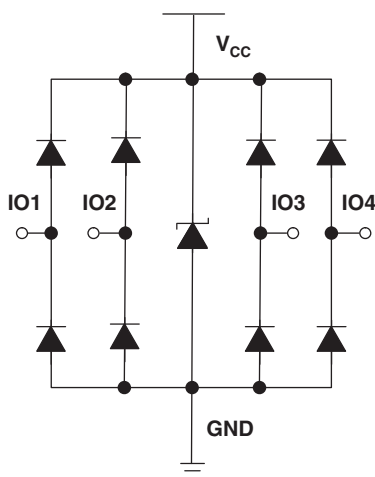

### 7.3 Feature Description

TPD4E004 is a TVS which provides ESD protection for up to four channels, withstanding up to  $\pm 8$ -kV contact and  $\pm 12$ -kV air-gap ESD per IEC 61000-4-2. The monolithic technology yields exceptionally small variations in capacitance between any IO pin of TPD4E004. The small footprint is ideal for applications where space-saving designs are important.

### 7.4 Device Functional Modes

The TPD4E004 device is a passive integrated circuit that triggers when voltages are above  $V_{BR}$  or below the diodes  $V_F$  of approximately  $-0.3$  V. During ESD events, voltages as high as  $\pm 8$ -kV contact and  $\pm 12$ -kV air-gap ESD can be directed to ground via the internal diodes. Once the voltages on the protected line fall below the trigger levels of TPD4E004 (usually within 10's of nano-seconds) the device reverts back to its high-impedance state.

## 8 Application and Implementation

### NOTE

Information in the following applications sections is not part of the TI component specification, and TI does not warrant its accuracy or completeness. TI's customers are responsible for determining suitability of components for their purposes. Customers should validate and test their design implementation to confirm system functionality.

### 8.1 Application Information

TPD4E004 is a diode array type TVS which is typically used to provide a path to ground for dissipating ESD events on hi-speed signal lines between a human interface connector and a system. As the current from ESD passes through the TVS, only a small voltage drop is present across the diode. This is the voltage presented to the protected IC. The low  $R_{DYN}$  of the triggered TVS holds this voltage,  $V_{CLAMP}$ , to a tolerable level for the protected IC.

### 8.2 Typical Application

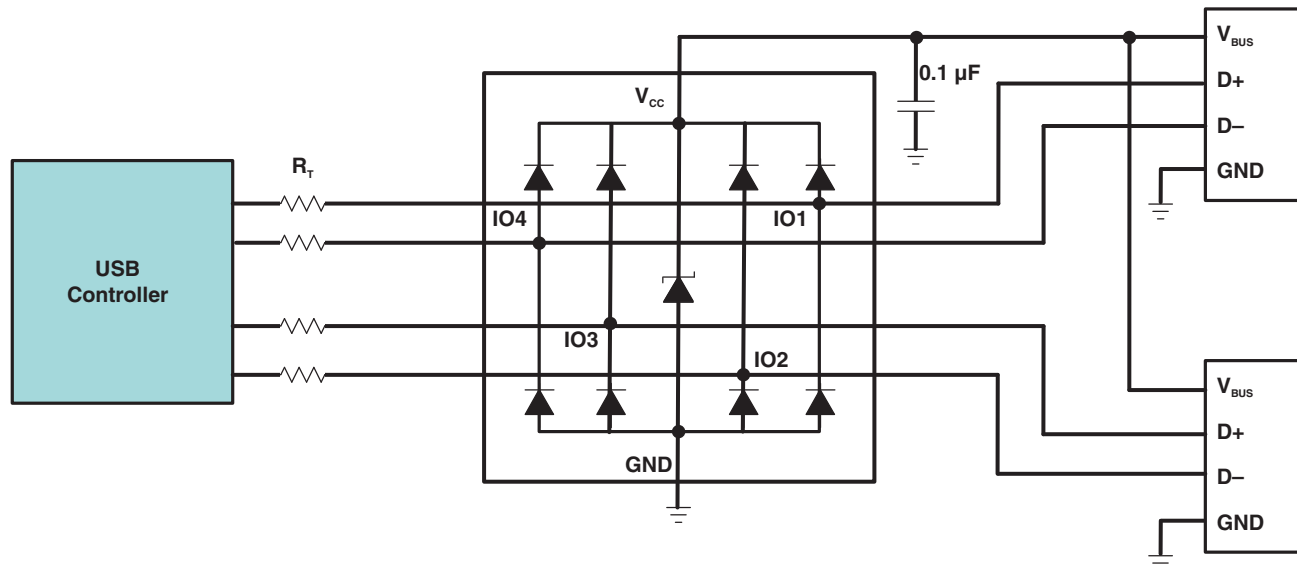

Figure 5. Application Schematic

#### 8.2.1 Design Requirements

For this design example, a single TPD4E004 is used to protect all the pins of two USB2.0 connectors. [Table 1](#) lists the design parameters for the USB application.

Table 1. Design Parameters

DESIGN PARAMETER	VALUE
Signal range on IO1, IO2, IO3, and IO4	0 V to 3.6 V
Signal voltage range on $V_{CC}$	0 V to 5.5 V
Operating Frequency	240 MHz

#### 8.2.2 Detailed Design Procedure

When placed near the USB connectors, the TPD4E004 ESD solution offers little or no signal distortion during normal operation due to low IO capacitance and ultra-low leakage current specifications. The TPD4E004 ensures that the core circuitry is protected and the system is functioning properly in the event of an ESD strike. For proper operation, see the the following layout and design guidelines should be followed:

1. Place the TPD4E004 solution close to the connectors. This allows the TPD4E004 to take away the energy

associated with ESD strike before it reaches the internal circuitry of the system board.

2. Place a 0.1- $\mu$ F capacitor very close to the  $V_{CC}$  pin. This limits any momentary voltage surge at the IO pin during the ESD strike event.
3. Ensure that there is enough metallization for the  $V_{CC}$  and GND loop. During normal operation, the TPD4E004 consumes nA leakage current. But during the ESD event,  $V_{CC}$  and GND may see 15-A to 30-A of current, depending on the ESD level. Sufficient current path enables safe discharge of all the energy associated with the ESD strike.
4. Leave the unused IO pins floating. In this example of protecting two USB ports, none of the IO pins will be left unused.
5. The  $V_{CC}$  pin can be connected in two different ways:
  - (a) If the  $V_{CC}$  pin is connected to the system power supply, the TPD4E004 works as a transient suppressor for any signal swing above  $V_{CC} + V_F$ . A 0.1- $\mu$ F capacitor on the device  $V_{CC}$  pin is recommended for ESD bypass.
  - (b) If the  $V_{CC}$  pin is not connected to the system power supply, the TPD4E004 can tolerate higher signal swing in the range up to 5.8 V. Please note that a 0.1- $\mu$ F capacitor is still recommended at the  $V_{CC}$  pin for ESD bypass.

### 8.2.3 Application Curves

Figure 6 is a capture of the voltage clamping waveform of TPD4E004 during an +8kV Contact IEC 61000-4-2 ESD strike.

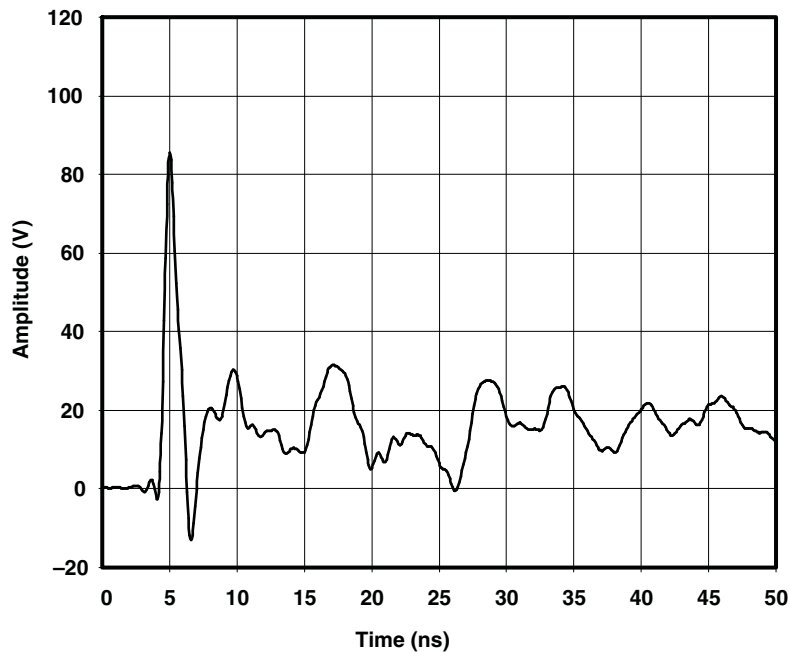

**Figure 6. IEC ESD Clamping Waveforms +8-KV Contact**

## 9 Power Supply Recommendations

This device is a passive ESD protection device so there is no need to power it. Make sure that the maximum voltage specifications for each pin are not violated.

## 10 Layout

### 10.1 Layout Guidelines

- The optimum placement is as close to the connector as possible.
  - EMI during an ESD event can couple from the trace being struck to other nearby unprotected traces, resulting in early system failures.
  - The PCB designer needs to minimize the possibility of EMI coupling by keeping any unprotected traces away from the protected traces which are between the TVS and the connector.
- Route the protected traces as straight as possible.
- Eliminate any sharp corners on the protected traces between the TVS and the connector by using rounded corners with the largest radii possible.
  - Electric fields tend to build up on corners, increasing EMI coupling.

### 10.2 Layout Example

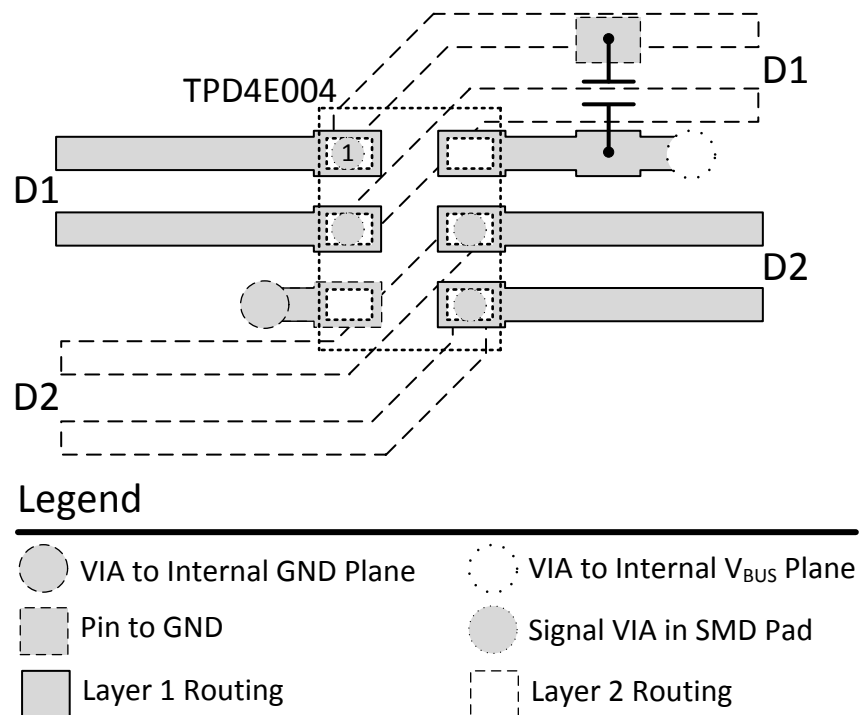

**Figure 7. TPD4E004 Layout Example**

## 11 Device and Documentation Support

### 11.1 Documentation Support

#### 11.1.1 Related Documentation

For related documentation see the following:

- *Reading and Understanding an ESD Protection Datasheet*, [SLLA305](#)
- *ESD Protection Layout Guide*, [SLVA680](#)

### 11.2 Community Resources

The following links connect to TI community resources. Linked contents are provided "AS IS" by the respective contributors. They do not constitute TI specifications and do not necessarily reflect TI's views; see TI's [Terms of Use](#).

**TI E2E™ Online Community** *TI's Engineer-to-Engineer (E2E) Community*. Created to foster collaboration among engineers. At [e2e.ti.com](#), you can ask questions, share knowledge, explore ideas and help solve problems with fellow engineers.

**Design Support** *TI's Design Support* Quickly find helpful E2E forums along with design support tools and contact information for technical support.

### 11.3 Trademarks

E2E is a trademark of Texas Instruments.

All other trademarks are the property of their respective owners.

### 11.4 Electrostatic Discharge Caution



These devices have limited built-in ESD protection. The leads should be shorted together or the device placed in conductive foam during storage or handling to prevent electrostatic damage to the MOS gates.

### 11.5 Glossary

[SLYZ022](#) — *TI Glossary*.

This glossary lists and explains terms, acronyms, and definitions.

## 12 Mechanical, Packaging, and Orderable Information

The following pages include mechanical, packaging, and orderable information. This information is the most current data available for the designated devices. This data is subject to change without notice and revision of this document. For browser-based versions of this data sheet, refer to the left-hand navigation.

**PACKAGING INFORMATION**

Orderable Device	Status (1)	Package Type	Package Drawing	Pins	Package Qty	Eco Plan (2)	Lead/Ball Finish (6)	MSL Peak Temp (3)	Op Temp (°C)	Device Marking (4/5)	Samples
TPD4E004DRYR	ACTIVE	SON	DRY	6	5000	Green (RoHS & no Sb/Br)	CU NIPDAU	Level-1-260C-UNLIM	-40 to 85	2P	<a href="#">Samples</a>
TPD4E004DRYRG4	ACTIVE	SON	DRY	6	5000	Green (RoHS & no Sb/Br)	CU NIPDAU	Level-1-260C-UNLIM	-40 to 85	2P	<a href="#">Samples</a>

(1) The marketing status values are defined as follows:

**ACTIVE:** Product device recommended for new designs.

**LIFEBUY:** TI has announced that the device will be discontinued, and a lifetime-buy period is in effect.

**NRND:** Not recommended for new designs. Device is in production to support existing customers, but TI does not recommend using this part in a new design.

**PREVIEW:** Device has been announced but is not in production. Samples may or may not be available.

**OBSOLETE:** TI has discontinued the production of the device.

(2) Eco Plan - The planned eco-friendly classification: Pb-Free (RoHS), Pb-Free (RoHS Exempt), or Green (RoHS & no Sb/Br) - please check <http://www.ti.com/productcontent> for the latest availability information and additional product content details.

**TBD:** The Pb-Free/Green conversion plan has not been defined.

**Pb-Free (RoHS):** TI's terms "Lead-Free" or "Pb-Free" mean semiconductor products that are compatible with the current RoHS requirements for all 6 substances, including the requirement that lead not exceed 0.1% by weight in homogeneous materials. Where designed to be soldered at high temperatures, TI Pb-Free products are suitable for use in specified lead-free processes.

**Pb-Free (RoHS Exempt):** This component has a RoHS exemption for either 1) lead-based flip-chip solder bumps used between the die and package, or 2) lead-based die adhesive used between the die and leadframe. The component is otherwise considered Pb-Free (RoHS compatible) as defined above.

**Green (RoHS & no Sb/Br):** TI defines "Green" to mean Pb-Free (RoHS compatible), and free of Bromine (Br) and Antimony (Sb) based flame retardants (Br or Sb do not exceed 0.1% by weight in homogeneous material)

(3) MSL, Peak Temp. - The Moisture Sensitivity Level rating according to the JEDEC industry standard classifications, and peak solder temperature.

(4) There may be additional marking, which relates to the logo, the lot trace code information, or the environmental category on the device.

(5) Multiple Device Markings will be inside parentheses. Only one Device Marking contained in parentheses and separated by a "~" will appear on a device. If a line is indented then it is a continuation of the previous line and the two combined represent the entire Device Marking for that device.

(6) Lead/Ball Finish - Orderable Devices may have multiple material finish options. Finish options are separated by a vertical ruled line. Lead/Ball Finish values may wrap to two lines if the finish value exceeds the maximum column width.

**Important Information and Disclaimer:** The information provided on this page represents TI's knowledge and belief as of the date that it is provided. TI bases its knowledge and belief on information provided by third parties, and makes no representation or warranty as to the accuracy of such information. Efforts are underway to better integrate information from third parties. TI has taken and continues to take reasonable steps to provide representative and accurate information but may not have conducted destructive testing or chemical analysis on incoming materials and chemicals. TI and TI suppliers consider certain information to be proprietary, and thus CAS numbers and other limited information may not be available for release.

In no event shall TI's liability arising out of such information exceed the total purchase price of the TI part(s) at issue in this document sold by TI to Customer on an annual basis.

## TAPE AND REEL INFORMATION



### QUADRANT ASSIGNMENTS FOR PIN 1 ORIENTATION IN TAPE



\*All dimensions are nominal

Device	Package Type	Package Drawing	Pins	SPQ	Reel Diameter (mm)	Reel Width W1 (mm)	A0 (mm)	B0 (mm)	K0 (mm)	P1 (mm)	W (mm)	Pin1 Quadrant
TPD4E004DRYR	SON	DRY	6	5000	179.0	8.4	1.2	1.65	0.7	4.0	8.0	Q1
TPD4E004DRYR	SON	DRY	6	5000	180.0	9.5	1.2	1.65	0.7	4.0	8.0	Q1

TAPE AND REEL BOX DIMENSIONS



\*All dimensions are nominal

Device	Package Type	Package Drawing	Pins	SPQ	Length (mm)	Width (mm)	Height (mm)
TPD4E004DRYR	SON	DRY	6	5000	203.0	203.0	35.0
TPD4E004DRYR	SON	DRY	6	5000	189.0	185.0	36.0

## GENERIC PACKAGE VIEW

**DRY 6**

**USON - 0.6 mm max height**

PLASTIC SMALL OUTLINE - NO LEAD



Images above are just a representation of the package family, actual package may vary.  
Refer to the product data sheet for package details.

4207181/G



# EXAMPLE BOARD LAYOUT

DRY0006A

USON - 0.6 mm max height

PLASTIC SMALL OUTLINE - NO LEAD

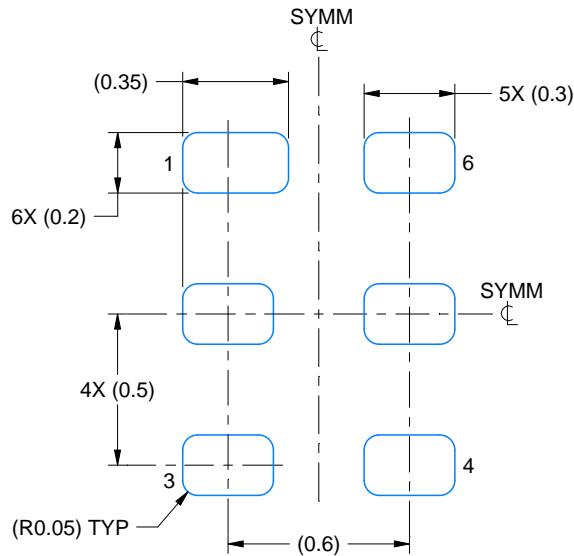

LAND PATTERN EXAMPLE  
1:1 RATIO WITH PKG SOLDER PADS  
EXPOSED METAL SHOWN  
SCALE:40X

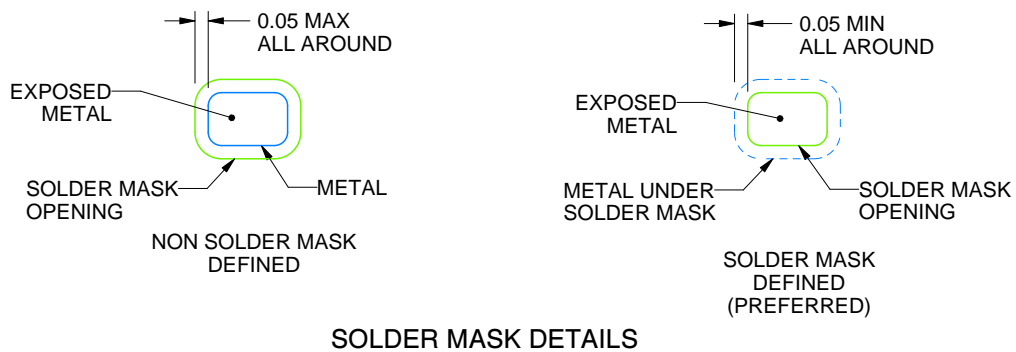

SOLDER MASK DETAILS

4222894/A 01/2018

NOTES: (continued)

3. For more information, see QFN/SON PCB application report in literature No. SLUA271 ([www.ti.com/lit/sluea271](http://www.ti.com/lit/sluea271)).

# EXAMPLE STENCIL DESIGN

DRY0006A

USON - 0.6 mm max height

PLASTIC SMALL OUTLINE - NO LEAD

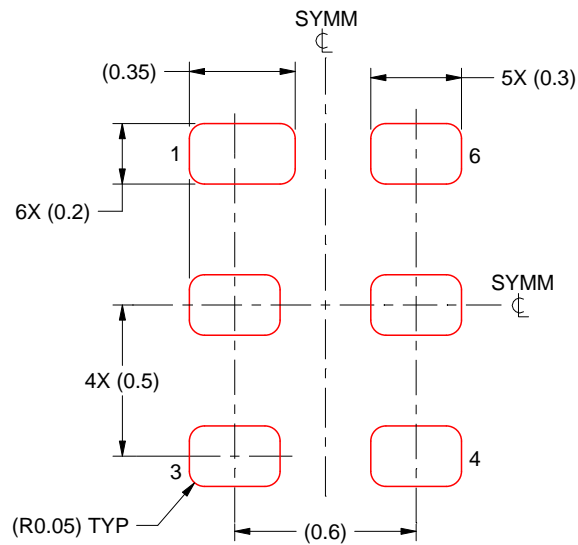

SOLDER PASTE EXAMPLE  
BASED ON 0.075 - 0.1 mm THICK STENCIL  
SCALE:40X

4222894/A 01/2018

NOTES: (continued)

4. Laser cutting apertures with trapezoidal walls and rounded corners may offer better paste release. IPC-7525 may have alternate design recommendations.

## IMPORTANT NOTICE

Texas Instruments Incorporated (TI) reserves the right to make corrections, enhancements, improvements and other changes to its semiconductor products and services per JESD46, latest issue, and to discontinue any product or service per JESD48, latest issue. Buyers should obtain the latest relevant information before placing orders and should verify that such information is current and complete.

TI's published terms of sale for semiconductor products (<http://www.ti.com/sc/docs/stdterms.htm>) apply to the sale of packaged integrated circuit products that TI has qualified and released to market. Additional terms may apply to the use or sale of other types of TI products and services.

Reproduction of significant portions of TI information in TI data sheets is permissible only if reproduction is without alteration and is accompanied by all associated warranties, conditions, limitations, and notices. TI is not responsible or liable for such reproduced documentation. Information of third parties may be subject to additional restrictions. Resale of TI products or services with statements different from or beyond the parameters stated by TI for that product or service voids all express and any implied warranties for the associated TI product or service and is an unfair and deceptive business practice. TI is not responsible or liable for any such statements.

Buyers and others who are developing systems that incorporate TI products (collectively, "Designers") understand and agree that Designers remain responsible for using their independent analysis, evaluation and judgment in designing their applications and that Designers have full and exclusive responsibility to assure the safety of Designers' applications and compliance of their applications (and of all TI products used in or for Designers' applications) with all applicable regulations, laws and other applicable requirements. Designer represents that, with respect to their applications, Designer has all the necessary expertise to create and implement safeguards that (1) anticipate dangerous consequences of failures, (2) monitor failures and their consequences, and (3) lessen the likelihood of failures that might cause harm and take appropriate actions. Designer agrees that prior to using or distributing any applications that include TI products, Designer will thoroughly test such applications and the functionality of such TI products as used in such applications.

TI's provision of technical, application or other design advice, quality characterization, reliability data or other services or information, including, but not limited to, reference designs and materials relating to evaluation modules, (collectively, "TI Resources") are intended to assist designers who are developing applications that incorporate TI products; by downloading, accessing or using TI Resources in any way, Designer (individually or, if Designer is acting on behalf of a company, Designer's company) agrees to use any particular TI Resource solely for this purpose and subject to the terms of this Notice.

TI's provision of TI Resources does not expand or otherwise alter TI's applicable published warranties or warranty disclaimers for TI products, and no additional obligations or liabilities arise from TI providing such TI Resources. TI reserves the right to make corrections, enhancements, improvements and other changes to its TI Resources. TI has not conducted any testing other than that specifically described in the published documentation for a particular TI Resource.

Designer is authorized to use, copy and modify any individual TI Resource only in connection with the development of applications that include the TI product(s) identified in such TI Resource. NO OTHER LICENSE, EXPRESS OR IMPLIED, BY ESTOPPEL OR OTHERWISE TO ANY OTHER TI INTELLECTUAL PROPERTY RIGHT, AND NO LICENSE TO ANY TECHNOLOGY OR INTELLECTUAL PROPERTY RIGHT OF TI OR ANY THIRD PARTY IS GRANTED HEREIN, including but not limited to any patent right, copyright, mask work right, or other intellectual property right relating to any combination, machine, or process in which TI products or services are used. Information regarding or referencing third-party products or services does not constitute a license to use such products or services, or a warranty or endorsement thereof. Use of TI Resources may require a license from a third party under the patents or other intellectual property of the third party, or a license from TI under the patents or other intellectual property of TI.

TI RESOURCES ARE PROVIDED "AS IS" AND WITH ALL FAULTS. TI DISCLAIMS ALL OTHER WARRANTIES OR REPRESENTATIONS, EXPRESS OR IMPLIED, REGARDING RESOURCES OR USE THEREOF, INCLUDING BUT NOT LIMITED TO ACCURACY OR COMPLETENESS, TITLE, ANY EPIDEMIC FAILURE WARRANTY AND ANY IMPLIED WARRANTIES OF MERCHANTABILITY, FITNESS FOR A PARTICULAR PURPOSE, AND NON-INFRINGEMENT OF ANY THIRD PARTY INTELLECTUAL PROPERTY RIGHTS. TI SHALL NOT BE LIABLE FOR AND SHALL NOT DEFEND OR INDEMNIFY DESIGNER AGAINST ANY CLAIM, INCLUDING BUT NOT LIMITED TO ANY INFRINGEMENT CLAIM THAT RELATES TO OR IS BASED ON ANY COMBINATION OF PRODUCTS EVEN IF DESCRIBED IN TI RESOURCES OR OTHERWISE. IN NO EVENT SHALL TI BE LIABLE FOR ANY ACTUAL, DIRECT, SPECIAL, COLLATERAL, INDIRECT, PUNITIVE, INCIDENTAL, CONSEQUENTIAL OR EXEMPLARY DAMAGES IN CONNECTION WITH OR ARISING OUT OF TI RESOURCES OR USE THEREOF, AND REGARDLESS OF WHETHER TI HAS BEEN ADVISED OF THE POSSIBILITY OF SUCH DAMAGES.

Unless TI has explicitly designated an individual product as meeting the requirements of a particular industry standard (e.g., ISO/TS 16949 and ISO 26262), TI is not responsible for any failure to meet such industry standard requirements.

Where TI specifically promotes products as facilitating functional safety or as compliant with industry functional safety standards, such products are intended to help enable customers to design and create their own applications that meet applicable functional safety standards and requirements. Using products in an application does not by itself establish any safety features in the application. Designers must ensure compliance with safety-related requirements and standards applicable to their applications. Designer may not use any TI products in life-critical medical equipment unless authorized officers of the parties have executed a special contract specifically governing such use. Life-critical medical equipment is medical equipment where failure of such equipment would cause serious bodily injury or death (e.g., life support, pacemakers, defibrillators, heart pumps, neurostimulators, and implantables). Such equipment includes, without limitation, all medical devices identified by the U.S. Food and Drug Administration as Class III devices and equivalent classifications outside the U.S.

TI may expressly designate certain products as completing a particular qualification (e.g., Q100, Military Grade, or Enhanced Product). Designers agree that it has the necessary expertise to select the product with the appropriate qualification designation for their applications and that proper product selection is at Designers' own risk. Designers are solely responsible for compliance with all legal and regulatory requirements in connection with such selection.

Designer will fully indemnify TI and its representatives against any damages, costs, losses, and/or liabilities arising out of Designer's non-compliance with the terms and provisions of this Notice.

## Looking for pricing, stock, or lifecycle information?

Click below to explore more details on WIN SOURCE:

 [View TPD4E004DRYR on WIN SOURCE](#)

 [Texas Instruments](#) Information

## Optimize Your Supply Chain with WIN SOURCE Solutions

-  Global Sourcing Solution
-  Obsolete Management
-  Cost Control Management
-  Shortage Management
-  Alternative Solution
-  Excess Inventory Management