



**THE DATASHEET OF
TPA6211A1TDGNRQ1**



TPA6211A1-Q1 3.1W Mono Fully Differential Audio Power Amplifier

1 Features

- Qualified for automotive applications
 - Temperature Grade 2: -40°C to 105°C T_A
 - Device HBM ESD classification level 2
 - Device CDM ESD classification level C6
- 3.1W into 3Ω from a 5V supply at THD = 10% (typical)
- Low supply current: 4mA (typical) at 5V
- Shutdown current: $0.01\mu\text{A}$ (typical)
- Fast startup with minimal pop
- Only three external components
 - Improved PSRR (-80dB) and wide supply voltage (2.5V to 5.5V) for direct battery operation
 - Fully differential design reduces RF rectification
 - -63dB CMRR Eliminates two input coupling capacitors

2 Applications

- Automotive audio
- Emergency calls
- Driver notifications
- Cluster chimes

3 Description

The TPA6211A1-Q1 device is a 3.1W mono fully-differential amplifier designed to drive a speaker with at least 3Ω impedance while consuming only 20mm^2 total printed-circuit board (PCB) area in most applications. The device operates from 2.5V to 5.5V, drawing only 4mA of quiescent supply current. The TPA6211A1-Q1 device is available in the space-saving 8-pin HVSSOP package.

The device includes features such as a -80dB supply voltage rejection from 20Hz to 2kHz, improved RF-rectification immunity, small PCB area, and a fast start-up with minimal pop makes the TPA6211A1-Q1 device an excellent choice for emergency call applications. Additionally, the device supports low-power needs in infotainment and cluster applications, such as cluster chimes or driver notification.

Device Information

PART NUMBER	PACKAGE ⁽¹⁾	PACKAGE SIZE ⁽²⁾	BODY SIZE (NOM)
TPA6211A1-Q1	HVSSOP (8)	3.00mm × 4.90mm	3.00mm × 3.00mm

(1) For more information, see [Section 10](#).

(2) The package size (length × width) is a nominal value and includes pins, where applicable.

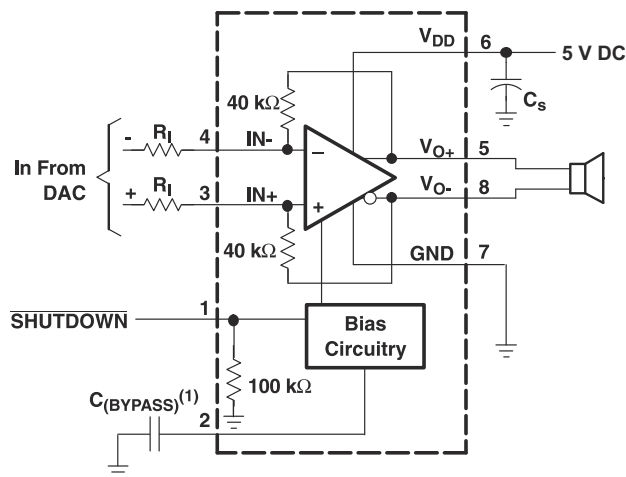

A. C_{BYPASS} is optional

Application Circuit



Table of Contents

1 Features	1	6.3 Feature Description.....	13
2 Applications	1	6.4 Device Functional Modes.....	18
3 Description	1	7 Application and Implementation	19
4 Pin Configuration and Functions	3	7.1 Application Information.....	19
Pin Functions.....	3	7.2 Typical Applications.....	19
4.1 DAPPER.....	3	7.3 Power Supply Recommendations.....	24
5 Specifications	4	7.4 Layout.....	25
5.1 Absolute Maximum Ratings.....	4	8 Device and Documentation Support	26
5.2 ESD Ratings.....	4	8.1 Receiving Notification of Documentation Updates....	26
5.3 Recommended Operating Conditions.....	4	8.2 Support Resources.....	26
5.4 Thermal Information.....	4	8.3 Trademarks.....	26
5.5 Electrical Characteristics.....	4	8.4 Electrostatic Discharge Caution.....	26
5.6 Operating Characteristics.....	6	8.5 Glossary.....	26
5.7 Dissipation Ratings.....	6	9 Revision History	26
6 Detailed Description	13	10 Mechanical, Packaging, and Orderable Information	27
6.1 Overview.....	13		
6.2 Functional Block Diagram.....	13		

4 Pin Configuration and Functions

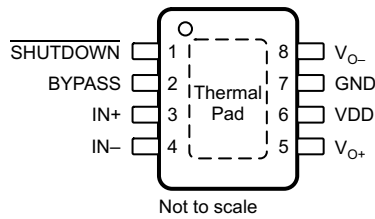

Figure 4-1. DGN Package 8-Pin HVSSOP Top View

Pin Functions

PIN		I/O	DESCRIPTION
NAME	NO.		
BYPASS	2	I	Mid-supply voltage, adding a bypass capacitor improves PSRR
GND	7	I	High-current ground
IN–	4	I	Negative differential input
IN+	3	I	Positive differential input
SHUTDOWN	1	I	Shutdown pin (active low logic)
Thermal Pad	—	—	Connect to ground. Thermal pad must be soldered down in all applications to properly secure device on the PCB.
V _{DD}	6	I	Power supply
V _{O+}	5	O	Positive BTL output
V _{O–}	8	O	Negative BTL output

4.1 DAPPER

NAME	NO.	TYPE	DESCRIPTION
BYPASS	2	I	Mid-supply voltage, adding a bypass capacitor improves PSRR
GND	7	I	High-current ground
IN–	4	I	Negative differential input
IN+	3	I	Positive differential input
SHUTDO WN	1	I	Shutdown pin (active low logic)
V _{DD}	6	I	Power supply
V _{O+}	5	O	Positive BTL output
V _{O–}	8	O	Negative BTL output
Thermal Pad	—	—	Connect to ground. Thermal pad must be soldered down in all applications to properly secure device on the PCB.

5 Specifications

5.1 Absolute Maximum Ratings

over operating free-air temperature range unless otherwise noted⁽¹⁾

	MIN	MAX	UNIT
Supply voltage, V_{DD}	-0.3	6	V
Input voltage, V_I	-0.3	$V_{DD} + 0.3$ V	V
Continuous total power dissipation	See Section 5.7		
Lead temperature 1.6 mm (1/16 Inch) from case for 10 s	DGN	260	°C
Operating free-air temperature, T_A	-40	105	°C
Junction temperature, T_J	-40	150	°C
Storage temperature, T_{stg}	-65	150	°C

- (1) Stresses beyond those listed under *Absolute Maximum Ratings* may cause permanent damage to the device. These are stress ratings only, which do not imply functional operation of the device at these or any other conditions beyond those indicated under [Section 5.3](#). Exposure to absolute-maximum-rated conditions for extended periods may affect device reliability.

5.2 ESD Ratings

	VALUE	UNIT
$V_{(ESD)}$ Electrostatic discharge	Human-body model (HBM), per AEC Q100-002 ⁽¹⁾	±2000
	Charged-device model (CDM), per AEC Q100-011	±1000

- (1) AEC Q100-002 indicates that HBM stressing shall be in accordance with the ANSI/ESDA/JEDEC JS-001 specification.

5.3 Recommended Operating Conditions

	MIN	MAX	UNIT
V_{DD} Supply voltage	2.5	5.5	V
V_{IH} High-level input voltage	SHUTDOWN		V
V_{IL} Low-level input voltage	SHUTDOWN	0.5	V
T_A Operating free-air temperature	-40	105	°C

5.4 Thermal Information

THERMAL METRIC ⁽¹⁾	TPA6211A1-Q1	UNIT
	DGN (HVSSOP)	
	8 PINS	
$R_{\theta JA}$ Junction-to-ambient thermal resistance	71.7	°C/W
$R_{\theta JC(top)}$ Junction-to-case (top) thermal resistance	55.9	°C/W
$R_{\theta JB}$ Junction-to-board thermal resistance	44.9	°C/W
ψ_{JT} Junction-to-top characterization parameter	3.7	°C/W
ψ_{JB} Junction-to-board characterization parameter	44.7	°C/W
$R_{\theta JC(bot)}$ Junction-to-case (bottom) thermal resistance	19.6	°C/W

- (1) For more information about traditional and new thermal metrics, see the [Semiconductor and IC Package Thermal Metrics](#) application report.

5.5 Electrical Characteristics

$T_A = 25^\circ\text{C}$

PARAMETER	TEST CONDITIONS	MIN	TYP	MAX	UNIT
V_{OS} Output offset voltage (measured differentially)	$V_I = 0$ -V differential, Gain = 1 V/V, $V_{DD} = 5.5$ V	-9	0.3	9	mV
PSRR Power supply rejection ratio	$V_{DD} = 2.5$ V to 5.5 V		-85	-60	dB
V_{IC} Common mode input range	$V_{DD} = 2.5$ V to 5.5 V	0.5		$V_{DD} - 0.8$	V

$T_A = 25^\circ\text{C}$

PARAMETER		TEST CONDITIONS	MIN	TYP	MAX	UNIT
CMRR	Common mode rejection ratio	$V_{DD} = 5.5\text{ V}, V_{IC} = 0.5\text{ V to }4.7\text{ V}$		-63	-40	dB
		$V_{DD} = 2.5\text{ V}, V_{IC} = 0.5\text{ V to }1.7\text{ V}$		-63	-40	
Low-output swing	$R_L = 4\ \Omega, V_{IN+} = V_{DD}, V_{IN+} = 0\text{ V},$ Gain = 1 V/V, $V_{IN-} = 0\text{ V}$ or $V_{IN-} = V_{DD}$	$V_{DD} = 5.5\text{ V}$		0.45		V
		$V_{DD} = 3.6\text{ V}$		0.37		
		$V_{DD} = 2.5\text{ V}$		0.26	0.4	
High-output swing	$R_L = 4\ \Omega, V_{IN+} = V_{DD}, V_{IN-} = V_{DD},$ Gain = 1 V/V, $V_{IN-} = 0\text{ V}$ or $V_{IN+} = 0\text{ V}$	$V_{DD} = 5.5\text{ V}$		4.95		V
		$V_{DD} = 3.6\text{ V}$		3.18		
		$V_{DD} = 2.5\text{ V}$	2	2.13		
$ I_{IH} $	High-level input current, shutdown	$V_{DD} = 5.5\text{ V}, V_I = 5.8\text{ V}$		58	100	μA
$ I_{IL} $	Low-level input current, shutdown	$V_{DD} = 5.5\text{ V}, V_I = -0.3\text{ V}$		3	100	μA
I_Q	Quiescent current	$V_{DD} = 2.5\text{ V to }5.5\text{ V},$ no load		4	5	mA
$I_{(SD)}$	Supply current	$V_{SHUTDOWN} \leq 0.5\text{ V}, V_{DD} = 2.5\text{ V to }5.5\text{ V}, R_L = 4\ \Omega$		0.01	1	μA
Gain	$R_L = 4\ \Omega$		$\frac{38\text{ k}\Omega}{R_1}$	$\frac{40\text{ k}\Omega}{R_1}$	$\frac{42\text{ k}\Omega}{R_1}$	V/V
Resistance from shutdown to GND				100		k Ω

5.6 Operating Characteristics

T_A = 25°C, Gain = 1 V/V

PARAMETER		TEST CONDITIONS		MIN	TYP	MAX	UNIT
P _O	Output power	THD + N = 1%, f = 1 kHz, R _L = 3 Ω	V _{DD} = 5 V		2.45		W
			V _{DD} = 3.6 V		1.22		
			V _{DD} = 2.5 V		0.49		
		THD + N = 1%, f = 1 kHz, R _L = 4 Ω	V _{DD} = 5 V		2.22		
			V _{DD} = 3.6 V		1.1		
			V _{DD} = 2.5 V		0.47		
		THD + N = 1%, f = 1 kHz, R _L = 8 Ω	V _{DD} = 5 V		1.36		
			V _{DD} = 3.6 V		0.72		
			V _{DD} = 2.5 V		0.33		
THD+N	Total harmonic distortion plus noise	f = 1 kHz, R _L = 3 Ω	P _O = 2 W, V _{DD} = 5 V		0.045%		
			P _O = 1 W, V _{DD} = 3.6 V		0.05%		
			P _O = 300 mW, V _{DD} = 2.5 V		0.06%		
		f = 1 kHz, R _L = 4 Ω	P _O = 1.8 W, V _{DD} = 5 V		0.03%		
			P _O = 0.7 W, V _{DD} = 3.6 V		0.03%		
			P _O = 300 mW, V _{DD} = 2.5 V		0.04%		
		f = 1 kHz, R _L = 8 Ω	P _O = 1 W, V _{DD} = 5 V		0.02%		
			P _O = 0.5 W, V _{DD} = 3.6 V		0.02%		
			P _O = 200 mW, V _{DD} = 2.5 V		0.03%		
k _{SVR}	Supply ripple rejection ratio	V _{DD} = 3.6 V, Inputs AC-grounded with C _I = 2 μF, V _{RIPPLE} = 200 mV _{pp}	f = 217 Hz		-80		dB
			f = 20 Hz to 20 kHz		-70		
SNR	Signal-to-noise ratio	V _{DD} = 5 V, P _O = 2 W, R _L = 4 Ω			105		dB
V _n	Output voltage noise	V _{DD} = 3.6 V, f = 20 Hz to 20 kHz, Inputs AC-grounded with C _I = 2 μF	No weighting		15		μV _{RMS}
			A weighting		12		
CMRR	Common mode rejection ratio	V _{DD} = 3.6 V, V _{IC} = 1 V _{pp}	f = 217 Hz		-65		dB
Z _I	Input impedance			38	40	44	kΩ
	Start-up time from shutdown	V _{DD} = 3.6 V, No C _{BYPASS}			4		μs
		V _{DD} = 3.6 V, C _{BYPASS} = 0.1 μF			27		ms

5.7 Dissipation Ratings

PACKAGE	T _A ≤ 25°C POWER RATING	DERATING FACTOR ⁽¹⁾	T _A = 70°C POWER RATING	T _A = 85°C POWER RATING
DGN	2.13 W	17.1 mW/°C	1.36 W	1.11 W

(1) Derating factor based on High-k board layout.

Typical Characteristics

Table 5-1. Table of Graphs

		FIGURE
Output power	vs Supply voltage	Figure 5-1
	vs Load resistance	Figure 5-2
Power dissipation	vs Output power	Figure 5-3, Figure 5-4
Total harmonic distortion + noise	vs Output power	Figure 5-5, Figure 5-6, Figure 5-7
	vs Frequency	Figure 5-8, Figure 5-9, Figure 5-10, Figure 5-11, Figure 5-12
	vs Common-mode input voltage	Figure 5-13
Supply voltage rejection ratio	vs Frequency	Figure 5-14, Figure 5-15, Figure 5-16, Figure 5-17
Supply voltage rejection ratio	vs Common-mode input voltage	Figure 5-18
GSM Power supply rejection	vs Time	Figure 5-19
GSM Power supply rejection	vs Frequency	Figure 5-20
Common-mode rejection ratio	vs Frequency	Figure 5-21
	vs Common-mode input voltage	Figure 5-22
Closed loop gain/phase	vs Frequency	Figure 5-23
Open loop gain/phase	vs Frequency	Figure 5-24
Supply current	vs Supply voltage	Figure 5-25
	vs Shutdown voltage	Figure 5-26
Start-up time	vs Bypass capacitor	Figure 5-27

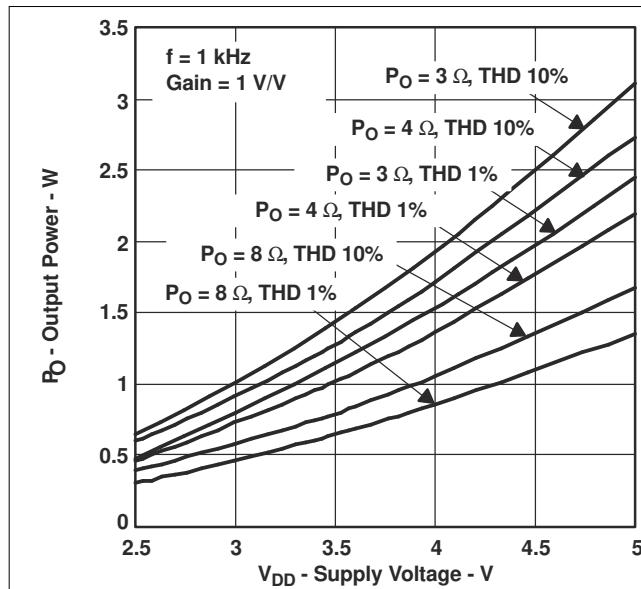

Figure 5-1. Output Power vs Supply Voltage

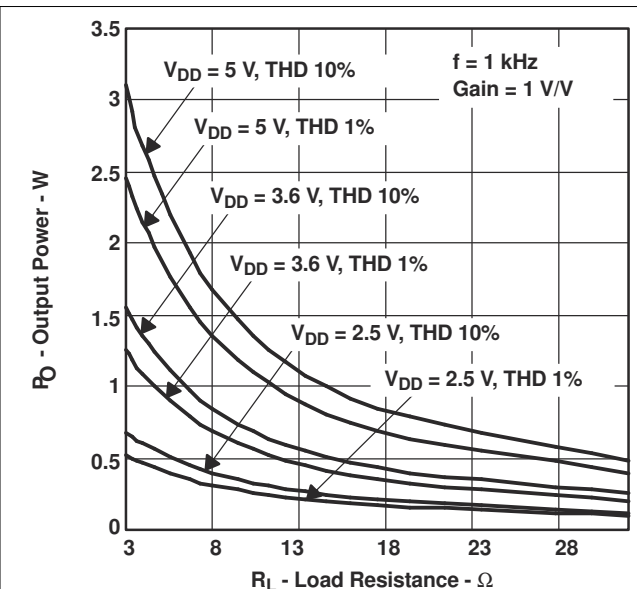

Figure 5-2. Output Power vs Load Resistance

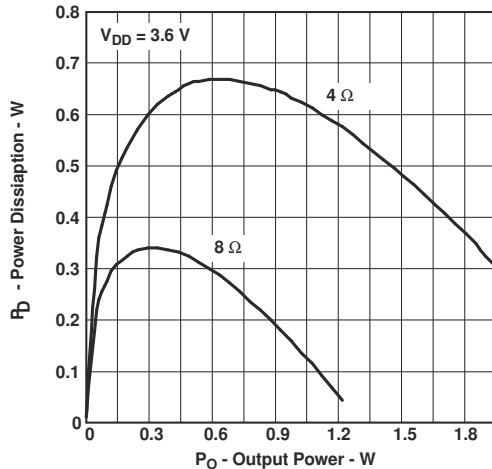

Figure 5-3. Power Dissipation vs Output Power

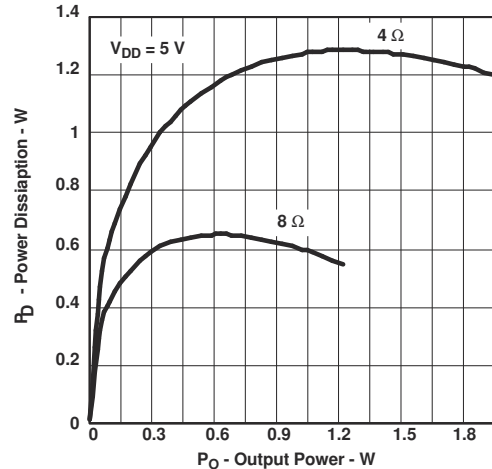

Figure 5-4. Power Dissipation vs Output Power

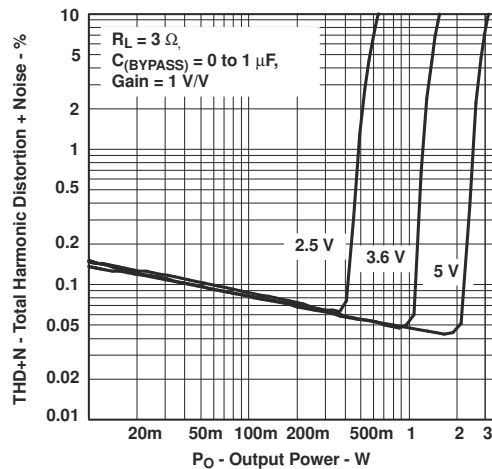

Figure 5-5. Total Harmonic Distortion + Noise vs Output Power

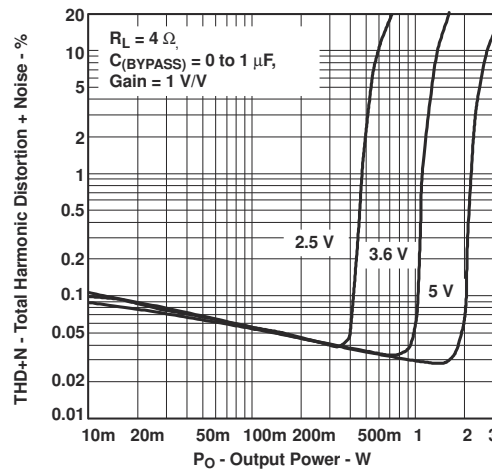

Figure 5-6. Total Harmonic Distortion + Noise vs Output Power

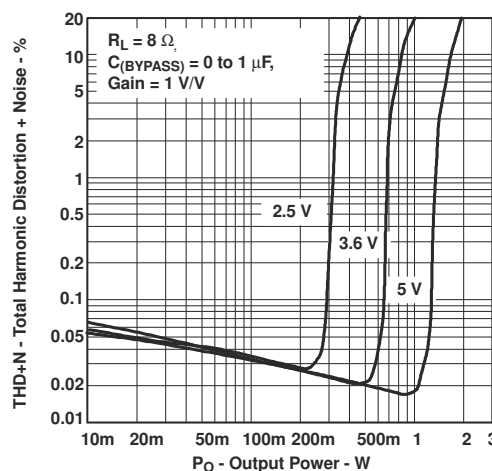

Figure 5-7. Total Harmonic Distortion + Noise vs Output Power

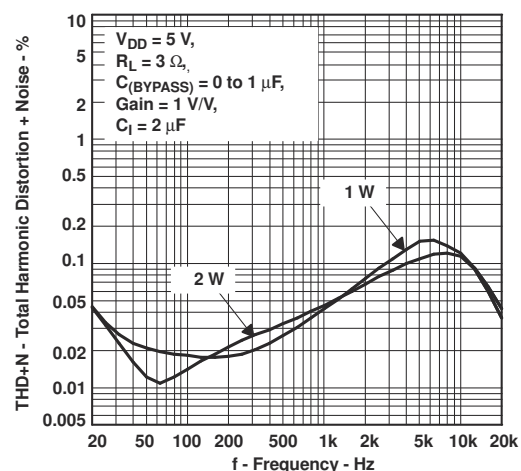

Figure 5-8. Total Harmonic Distortion + Noise vs Frequency

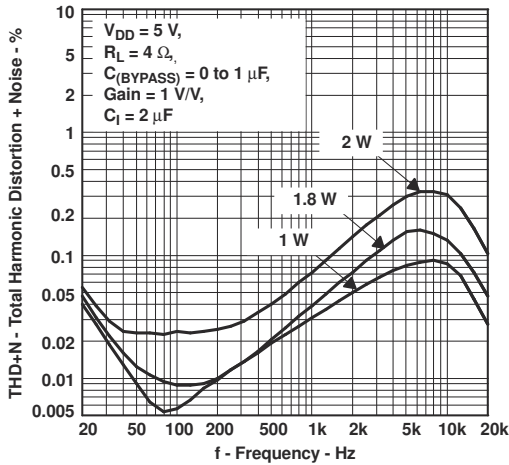

Figure 5-9. Total Harmonic Distortion + Noise vs Frequency

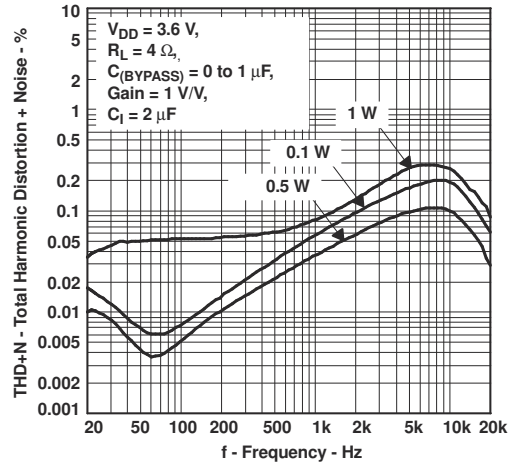

Figure 5-10. Total Harmonic Distortion + Noise vs Frequency

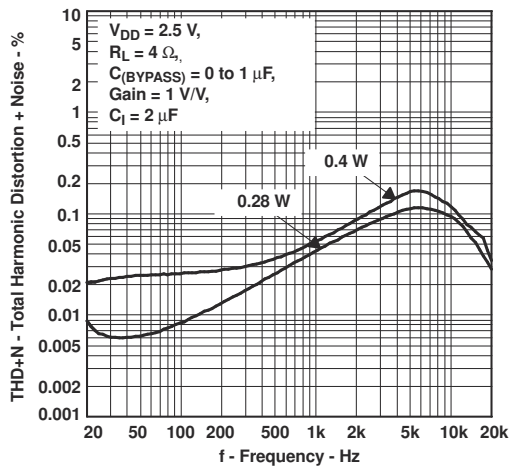

Figure 5-11. Total Harmonic Distortion + Noise vs Frequency

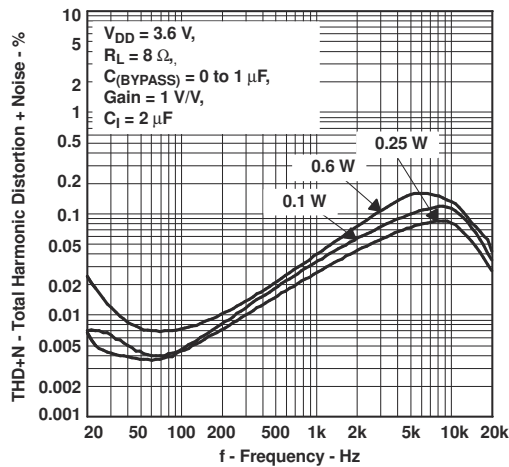

Figure 5-12. Total Harmonic Distortion + Noise vs Frequency

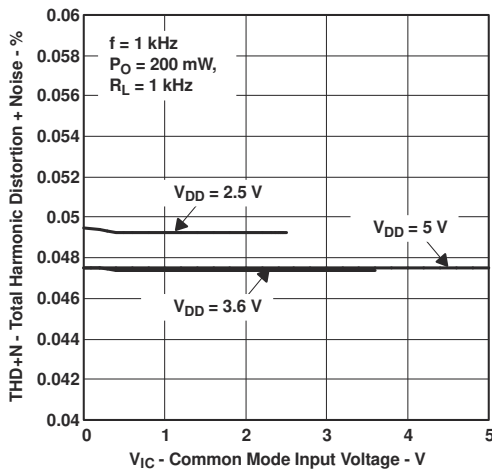

Figure 5-13. Total Harmonic Distortion + Noise vs Common-Mode Input Voltage

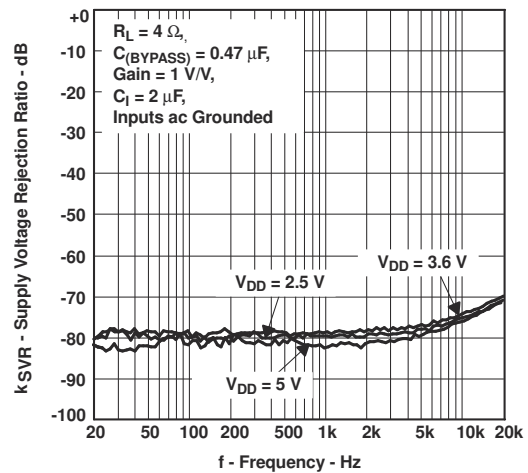

Figure 5-14. Supply Voltage Rejection Ratio vs Frequency

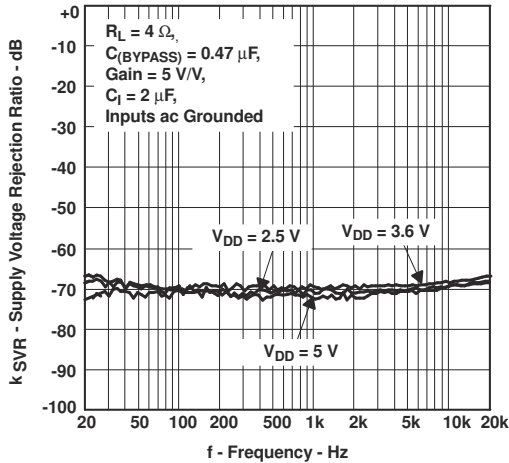

Figure 5-15. Supply Voltage Rejection Ratio vs Frequency

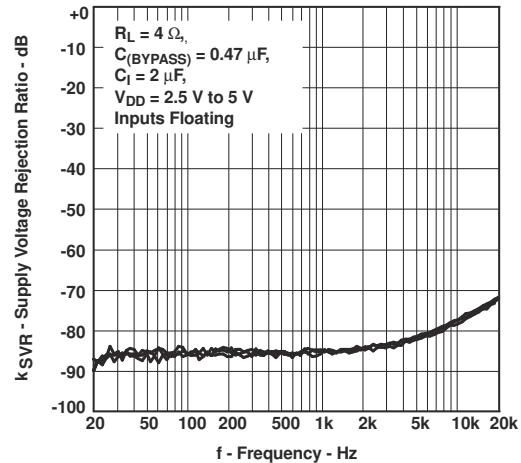

Figure 5-16. Supply Ripple Rejection Ratio vs Frequency

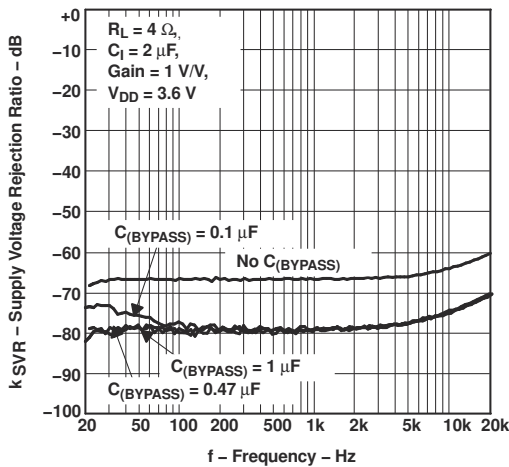

Figure 5-17. Supply Voltage Rejection Ratio vs Frequency

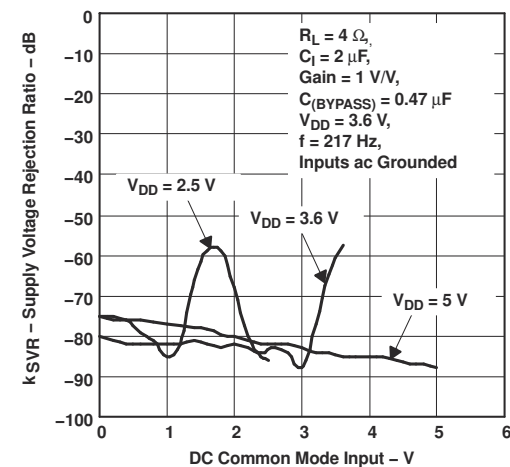

Figure 5-18. Supply Voltage Rejection Ratio vs DC Common-Mode Input

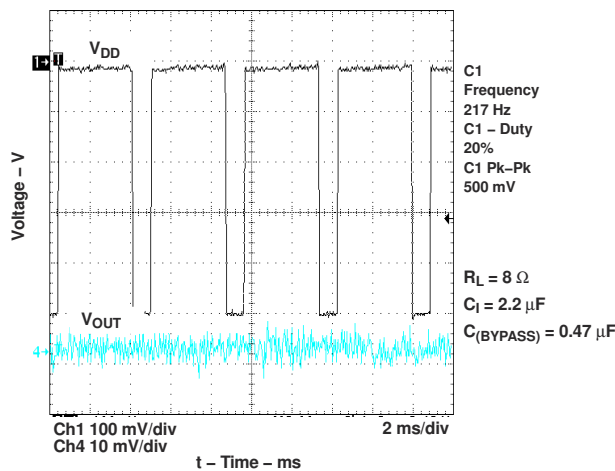

Figure 5-19. GSM Power Supply Rejection vs Time

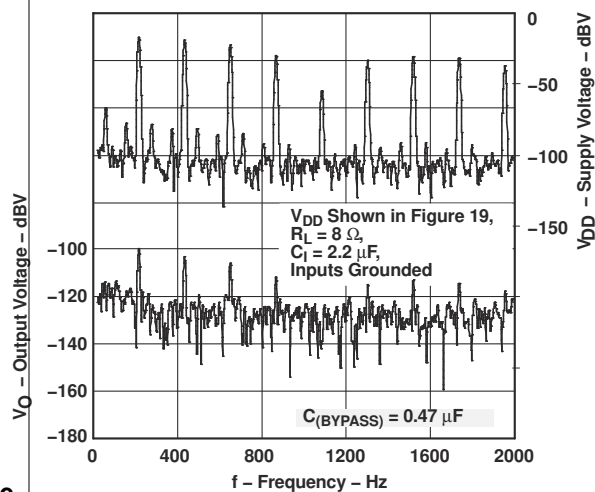

Figure 5-20. GSM Power Supply Rejection vs Frequency

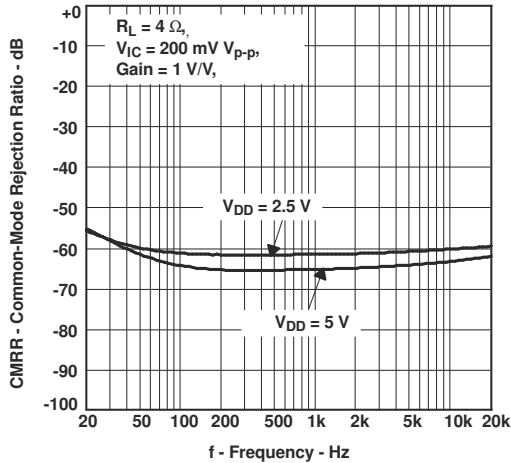

Figure 5-21. Common-Mode Rejection Ratio vs Frequency

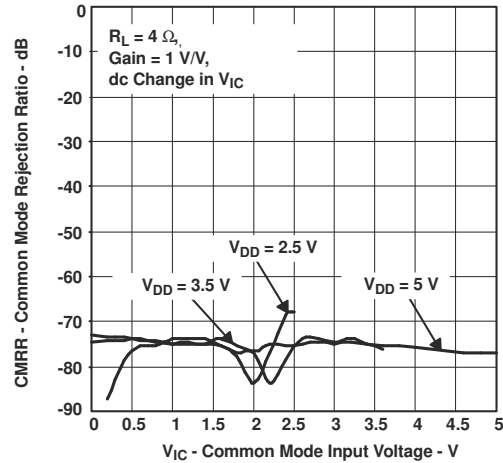

Figure 5-22. Common-Mode Rejection Ratio vs Common-Mode Input Voltage

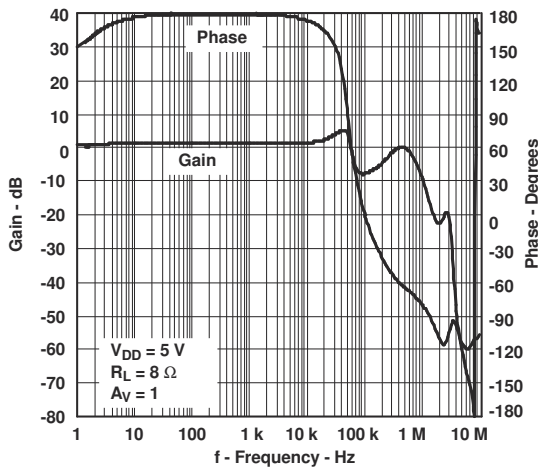

Figure 5-23. Closed Loop Gain/Phase vs Frequency

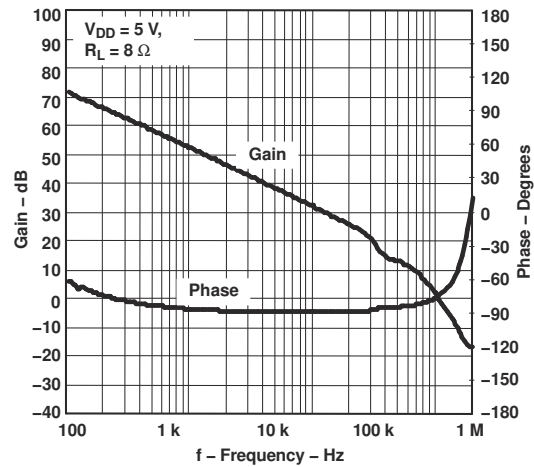

Figure 5-24. Open Loop Gain/Phase vs Frequency

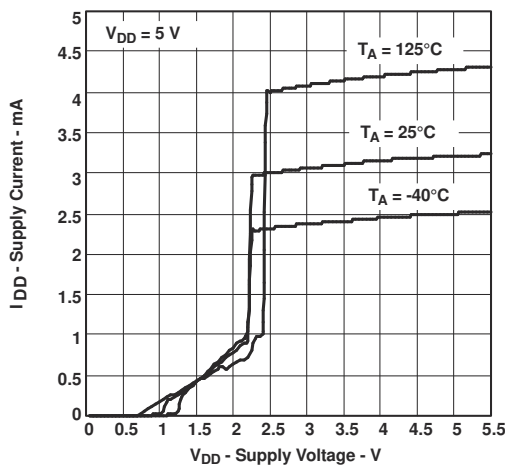

Figure 5-25. Supply Current vs Supply Voltage

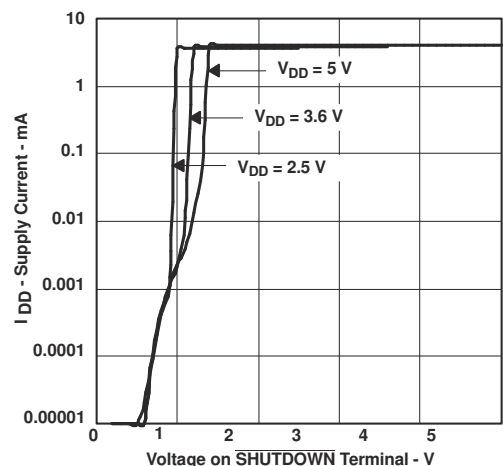

Figure 5-26. Supply Current vs Shutdown Voltage

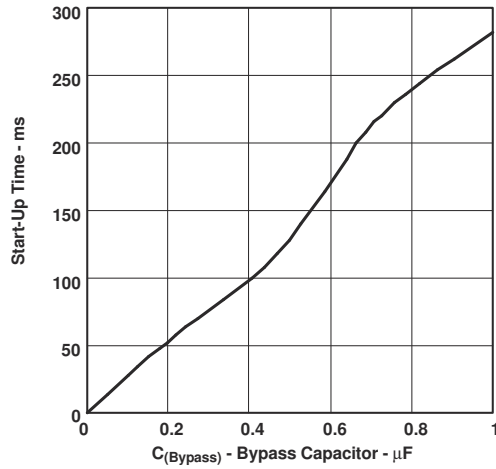

Figure 5-27. Start-up Time vs Bypass Capacitor

6 Detailed Description

6.1 Overview

The TPA6211A1-Q1 device is a fully differential amplifier with differential inputs and outputs. The fully differential amplifier consists of a differential amplifier and a common-mode amplifier. The differential amplifier ensures that the amplifier outputs a differential voltage that is equal to the differential input times the gain. The common-mode feedback ensures that the common-mode voltage at the output is biased around $V_{DD} / 2$ regardless of the common-mode voltage at the input.

6.2 Functional Block Diagram

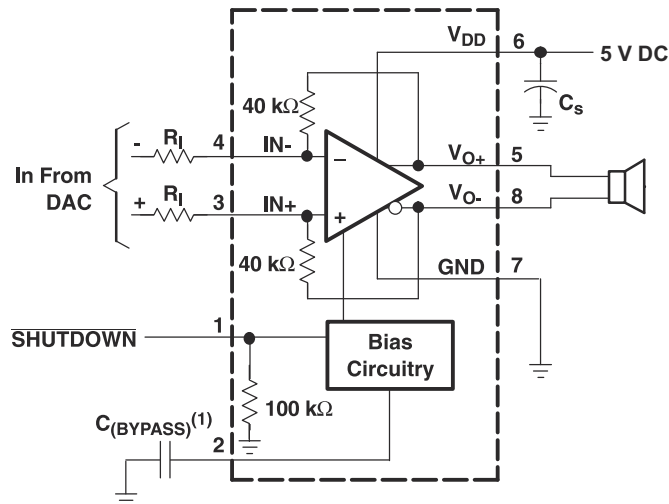

A. $C_{(BYPASS)}$ is optional

6.3 Feature Description

6.3.1 Advantages of Fully Differential Amplifiers

Input coupling capacitors are not required. A fully differential amplifier with good CMRR, such as the TPA6211A1-Q1 device, allows the inputs to be biased at voltage other than mid-supply. For example, if a DAC has a lower mid-supply voltage than that of the TPA6211A1-Q1 device, the common-mode feedback circuit compensates, and the outputs are still biased at the mid-supply point of the TPA6211A1-Q1 device. The inputs of the TPA6211A1-Q1 device can be biased from 0.5 V to $V_{DD} - 0.8$ V. If the inputs are biased outside of that range, input coupling capacitors are required.

A Mid-supply bypass capacitor, C_{BYPASS} , is not required. The fully differential amplifier does not require a bypass capacitor. Any shift in the mid-supply voltage affects both positive and negative channels equally, thus canceling at the differential output. Removing the bypass capacitor slightly worsens power supply rejection ratio (k_{SVR}), but a slight decrease of k_{SVR} can be acceptable when an additional component can be eliminated (see Figure 5-17).

The RF-immunity is improved. A fully differential amplifier cancels the noise from RF disturbances much better than the typical audio amplifier.

6.3.2 Fully Differential Amplifier Efficiency and Thermal Information

Class-AB amplifiers are inefficient, primarily because of voltage drop across the output-stage transistors. The two components of this internal voltage drop are the headroom or DC voltage drop that varies inversely to output power, and the sinewave nature of the output. The total voltage drop can be calculated by subtracting the RMS value of the output voltage from V_{DD} . The internal voltage drop multiplied by the average value of the supply current, $I_{DD}(avg)$, determines the internal power dissipation of the amplifier.

An easy-to-use equation to calculate efficiency starts out as being equal to the ratio of power from the power supply to the power delivered to the load. To accurately calculate the RMS and average values of power in the load and in the amplifier, the current and voltage waveform shapes must first be understood (see Figure 6-1).

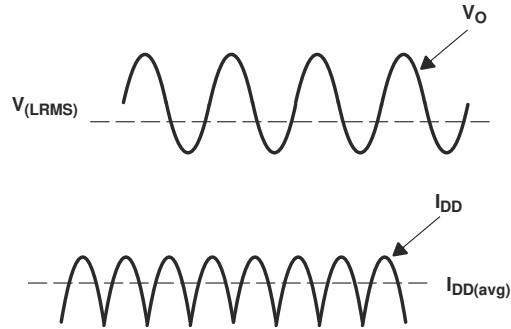

Figure 6-1. Voltage and Current Waveforms for BTL Amplifiers

Although the voltages and currents for SE and BTL are sinusoidal in the load, currents from the supply are different between SE and BTL configurations. In an SE application the current waveform is a half-wave rectified shape, whereas in BTL the current waveform is a full-wave rectified waveform. This means RMS conversion factors are different. Keep in mind that for most of the waveform both the push and pull transistors are not on at the same time, which supports the fact that each amplifier in the BTL device only draws current from the supply for half the waveform. Equation 2 to Equation 11 are the basis for calculating amplifier efficiency.

$$\text{Efficiency of a BTL amplifier} = \frac{P_L}{P_{SUP}}$$

Where:

$$P_L = \frac{V_{L\text{rms}}^2}{R_L}, \text{ and } V_{LRMS} = \frac{V_P}{\sqrt{2}}, \text{ therefore, } P_L = \frac{V_P^2}{2R_L}$$

$$\text{and } P_{SUP} = V_{DD} I_{DD\text{avg}} \text{ and } I_{DD\text{avg}} = \frac{1}{\pi} \int_0^\pi \frac{V_P}{R_L} \sin(t) dt = -\frac{1}{\pi} \times \frac{V_P}{R_L} [\cos(t)]_0^\pi = \frac{2V_P}{\pi R_L}$$

Therefore,

$$P_{SUP} = \frac{2 V_{DD} V_P}{\pi R_L}$$

substituting P_L and P_{SUP} into equation 6,

$$\text{Efficiency of a BTL amplifier} = \frac{\frac{V_P^2}{2R_L}}{\frac{2V_{DD}V_P}{\pi R_L}} = \frac{\pi V_P}{4V_{DD}}$$

Where:

$$V_P = \sqrt{2 P_L R_L}$$

$$\eta_{BTL} = \frac{P_L}{P_{SUP}}$$

- P_L = Power delivered to load
- P_{SUP} = Power drawn from power supply
- V_{LRMS} = RMS voltage on BTL load
- R_L = Load resistance
- V_P = Peak voltage on BTL load
- $I_{DD\text{avg}}$ = Average current drawn from the power supply
- V_{DD} = Power supply voltage
- η_{BTL} = Efficiency of a BTL amplifier

(1)

(2)

where

- η_{BTL} is the efficiency of a BTL amplifier
- P_L is the power delivered to load
- P_{SUP} is the power drawn from power supply

P_L is calculated with Equation 3, and V_{LRMS} is calculated with Equation 4.

$$P_L = \frac{V_{LRMS}^2}{R_L} \quad (3)$$

where

- V_{LRMS} = RMS voltage on BTL load
- R_L is load resistance

$$V_{LRMS} = \frac{V_P}{\sqrt{2}} \quad (4)$$

where

- V_P is peak voltage on BTL load

Therefore, P_L can be given as [Equation 5](#).

$$P_L = \frac{V_P^2}{2 \times R_L} \quad (5)$$

P_{SUP} is calculated with [Equation 6](#).

$$P_{SUP} = V_{DD} \times I_{DDavg} \quad (6)$$

where

- V_{DD} is power supply voltage
- I_{DDavg} is average current drawn from the power supply

I_{DDavg} is calculated with [Equation 7](#).

$$I_{DDavg} = \frac{1}{\pi} \int_0^{\pi} \frac{V_P}{R_L} \times \sin(t) \times dt = -\frac{1}{\pi} \times \frac{V_P}{R_L} \times \cos(t) \Big|_0^{\pi} = \frac{2 \times V_P}{\pi \times R_L} \quad (7)$$

Therefore, P_{SUP} can be given as [Equation 8](#).

$$P_{SUP} = \frac{2 \times V_{DD} \times V_P}{\pi \times R_L} \quad (8)$$

Substituting for P_L and P_{SUP} , [Equation 2](#) becomes [Equation 9](#)

$$\eta_{BTL} = \frac{\frac{V_P^2}{2 \times R_L}}{\frac{2 \times V_{DD} \times V_P}{\pi \times R_L}} = \frac{\pi \times V_P}{4 \times V_{DD}} \quad (9)$$

V_P is calculated with [Equation 10](#).

$$V_P = \sqrt{2 \times P_L \times R_L} \quad (10)$$

And substituting for V_P , η_{BTL} can be calculated with [Equation 11](#)

$$\eta_{BTL} = \frac{\pi \sqrt{2 \times P_L \times R_L}}{4 \times V_{DD}} \quad (11)$$

A simple formula for calculating the maximum power dissipated (P_{Dmax}) can be used for a differential output application:

$$P_{Dmax} = \frac{2V_{DD}^2}{\pi^2 R_L} \quad (12)$$

Table 6-1. Efficiency and Maximum Ambient Temperature vs Output Power

OUTPUT POWER	EFFICIENCY	INTERNAL DISSIPATION	POWER FROM SUPPLY	MAX AMBIENT TEMPERATURE
5-V, 3-Ω SYSTEMS				
0.5 W	27.2%	1.34 W	1.84 W	54°C
1 W	38.4%	1.6 W	2.6 W	35°C
2.45 W	60.2%	1.62 W	4.07 W	34°C
3.1 W	67.7%	1.48 W	4.58 W	44°C
5-V, 4-Ω BTL SYSTEMS				
0.5 W	31.4%	1.09 W	1.59 W	72°C
1 W	44.4%	1.25 W	2.25 W	60°C
2 W	62.8%	1.18 W	3.18 W	65°C
2.8 W	74.3%	0.97 W	3.77 W	80°C
5-V, 8-Ω SYSTEMS				
0.5 W	44.4%	0.625 W	1.13 W	105°C (limited by maximum ambient temperature specification)
1 W	62.8%	0.592 W	1.6 W	105°C (limited by maximum ambient temperature specification)
1.36 W	73.3%	0.496 W	1.86 W	105°C (limited by maximum ambient temperature specification)
1.7 W	81.9%	0.375 W	2.08 W	105°C (limited by maximum ambient temperature specification)

Equation 11 is used to calculate efficiencies for four different output power levels, see Table 6-1. The efficiency of the amplifier is quite low for lower power levels and rises sharply as power to the load is increased resulting in a nearly flat internal power dissipation over the normal operating range. The internal dissipation at full output power is less than in the half power range. Calculating the efficiency for a specific system is the key to proper power supply design. For a 2.8-W audio system with 4-Ω loads and a 5-V supply, the maximum draw on the power supply is almost 3.8 W.

A final point to remember about Class-AB amplifiers is how to manipulate the terms in the efficiency equation to the utmost advantage when possible. In Equation 11, V_{DD} is in the denominator. This indicates that as V_{DD} goes down, efficiency goes up.

The maximum ambient temperature depends on the heat sinking ability of the PCB system. Given $R_{\theta JA}$ (junction-to-ambient thermal resistance), the maximum allowable junction temperature, and the internal dissipation at 1-W output power with a 4-Ohm load, the maximum ambient temperature can be calculated with Equation 13. The maximum recommended junction temperature for the TPA6211A1-Q1 device is 150°C.

$$T_A(\text{Max}) = T_J(\text{Max}) - R_{\theta JA} \times P_D = 150 - 71.7 \times 1.25 = 60^\circ\text{C} \quad (13)$$

Equation 13 shows that the maximum ambient temperature is 60°C at 1-W output power and 4-Ohm load with a 5-V supply.

Table 6-1 shows that the thermal performance must be considered when using a Class-AB amplifier to keep junction temperatures in the specified range. The TPA6211A1-Q1 device is designed with thermal protection that turns the device off when the junction temperature surpasses 150°C to prevent damage to the IC. In addition,

using speakers with an impedance higher than 4 Ω dramatically increases the thermal performance by reducing the output current.

6.3.3 Differential Output Versus Single-Ended Output

Figure 6-2 shows a Class-AB audio power amplifier (APA) in a fully differential configuration. The TPA6211A1-Q1 amplifier has differential outputs driving both ends of the load. One of several potential benefits to this configuration is power to the load. The differential drive to the speaker means that as one side is slewing up, the other side is slewing down, and vice versa. This in effect doubles the voltage swing on the load as compared to a ground-referenced load. Plugging $2 \times V_{O(PP)}$ into the power equation (Equation 14) yields four-times the output power (as the voltage is squared) from the same supply rail and load impedance (see Equation 16 and Equation 17).

$$V_{(rms)} = \frac{V_{O(PP)}}{2\sqrt{2}}$$

$$\text{Power} = \frac{V_{(rms)}^2}{R_L} \tag{14}$$

$$\text{Power}_{(S-E)} = \frac{V_{(rms)}^2}{R_L} = \frac{\left(\frac{V_{O(PP)}}{2\sqrt{2}}\right)^2}{R_L} = \frac{V_{O(PP)}^2}{8R_L} \tag{15}$$

$$\text{Power}_{(Diff)} = \frac{V_{(rms)}^2}{R_L} = \frac{\left(\frac{2 \times V_{O(PP)}}{2\sqrt{2}}\right)^2}{R_L} = \frac{V_{O(PP)}^2}{2R_L} \tag{16}$$

$$\text{Power}_{(Diff)} = 4 \times \text{Power}_{(S-E)} \tag{17}$$

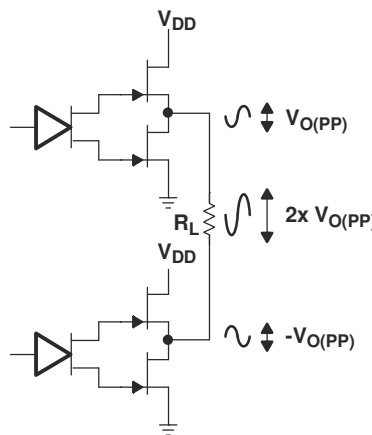

Figure 6-2. Differential Output Configuration

In a typical automotive application operating at 5 V, bridging raises the power into an 8-Ω speaker from a single-ended (SE, ground reference) limit of 390 mW to 1.56 W. This is a 6-dB improvement in sound power, or loudness of the sound. In addition to increased power, there are frequency-response concerns. Consider the single-supply SE configuration shown in Figure 6-3. A coupling capacitor (C_C) is required to block the DC-offset voltage from the load. This capacitor can be quite large (approximately 33 μF to 1000 μF) so it tends to be expensive, heavy, occupy valuable PCB area, and have the additional drawback of limiting low-frequency performance. This frequency-limiting effect is due to the high-pass filter network created with the speaker impedance and the coupling capacitance. This is calculated with Equation 18.

$$f_c = \frac{1}{2\pi R_L C_C} \quad (18)$$

For example, a 68- μ F capacitor with an 8- Ω speaker would attenuate low frequencies below 293 Hz. The BTL configuration cancels the DC offsets, which eliminates the need for the blocking capacitors. Low-frequency performance is then limited only by the input network and speaker response. Cost and PCB space are also minimized by eliminating the bulky coupling capacitor.

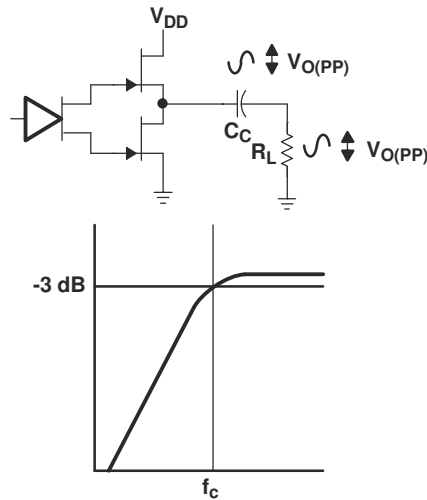

Figure 6-3. Single-Ended Output and Frequency Response

Increasing power to the load does carry a penalty of increased internal power dissipation. The increased dissipation is understandable considering that the BTL configuration produces four-times the output power of the SE configuration.

6.4 Device Functional Modes

The TPA6211A1-Q1 device can be put in shutdown mode when asserting SHUTDOWN pin to a logic LOW. While in shutdown mode, the device output stage is turned off and set into high impedance, making the current consumption very low. The device exits shutdown mode when a HIGH logic level is applied to SHUTDOWN pin.

7 Application and Implementation

Note

Information in the following applications sections is not part of the TI component specification, and TI does not warrant its accuracy or completeness. TI's customers are responsible for determining suitability of components for their purposes. Customers should validate and test their design implementation to confirm system functionality.

7.1 Application Information

The TPA6211A1-Q1 is a fully-differential amplifier designed to drive a speaker with at least 3-Ω impedance while consuming only 20-mm² total printed-circuit board (PCB) area in most applications.

7.2 Typical Applications

Figure 7-1 shows a typical application circuit for the TPA6211A1-Q1 with a speaker, input resistors, and supporting power supply decoupling capacitors.

7.2.1 Typical Differential Input Application

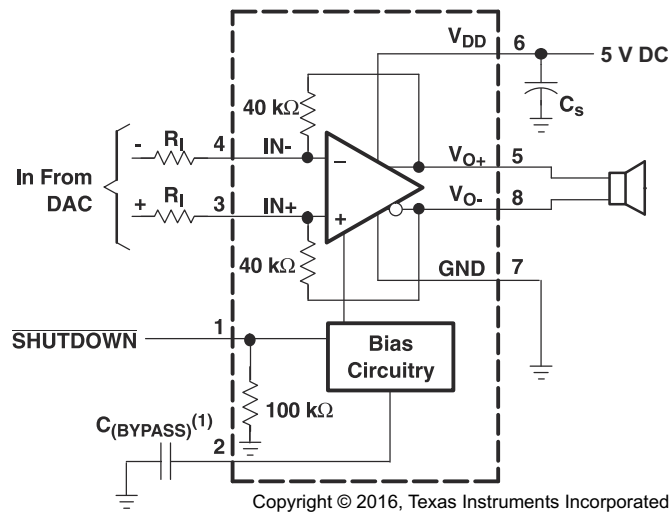

A. $C_{(BYPASS)}$ is optional

Figure 7-1. Typical Differential Input Application Schematic

Typical values are shown in Table 7-1.

Table 7-1. Typical Component Values

COMPONENT	VALUE
R_I	40 kΩ
$C_{BYPASS}^{(1)}$	0.22 μF
C_S	1 μF
C_I	0.22 μF

(1) C_{BYPASS} is optional.

7.2.1.1 Design Requirements

For this design example, use the parameters listed in Table 7-2 as the input parameters.

Table 7-2. Design Parameters

PARAMETER	EXAMPLE VALUE
Power supply voltage	2.5 V to 5.5 V

Table 7-2. Design Parameters (continued)

PARAMETER	EXAMPLE VALUE
Current	4 mA to 5 mA
Shutdown	High > 1.55 V
	Low < 0.5 V
Speaker	3 Ω, 4 Ω, or 8 Ω

7.2.1.2 Detailed Design Procedure

7.2.1.2.1 Resistors (R_I)

The input resistor (R_I) can be selected to set the gain of the amplifier according to [Equation 19](#).

$$\text{Gain} = \frac{R_F}{R_I} \quad (19)$$

The internal feedback resistors (R_F) are trimmed to 40 kΩ.

Resistor matching is very important in fully differential amplifiers. The balance of the output on the reference voltage depends on matched ratios of the resistors. CMRR, PSRR, and the cancellation of the second harmonic distortion diminishes if resistor mismatch occurs. Therefore, TI recommends 1%-tolerance resistors or better to optimize performance.

7.2.1.2.2 Bypass Capacitor (C_{BYPASS}) and Start-Up Time

The internal voltage divider at the BYPASS pin of this device sets a mid-supply voltage for internal references and sets the output common mode voltage to $V_{DD} / 2$. Adding a capacitor filters any noise into this pin, increasing k_{SVR} . C_{BYPASS} also determines the rise time of V_{O+} and V_{O-} when the device exits shutdown. The larger the capacitor, the slower the rise time.

7.2.1.2.3 Input Capacitor (C_I)

The TPA6211A1-Q1 device does not require input coupling capacitors when driven by a differential input source biased from 0.5 V to $V_{DD} - 0.8$ V. Use 1% tolerance or better gain-setting resistors if not using input coupling capacitors.

In the single-ended input application, an input capacitor (C_I) is required to allow the amplifier to bias the input signal to the proper DC level. In this case, C_I and R_I form a high-pass filter with the corner frequency defined in [Equation 20](#).

$$f_c = \frac{1}{2\pi R_I C_I} \quad (20)$$

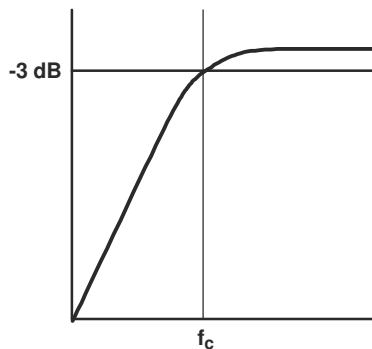
**Figure 7-2. Input Filter Cutoff Frequency**

The value of C_1 is an important consideration, as it directly affects the bass (low frequency) performance of the circuit. Consider the example where R_1 is 10 k Ω and the specification calls for a flat bass response down to 100 Hz. Equation 20 is reconfigured as Equation 21.

$$C_1 = \frac{1}{2\pi R_1 f_c} \quad (21)$$

In this example, C_1 is 0.16 μ F, so the likely choice ranges from 0.22 μ F to 0.47 μ F. TI recommends the use of ceramic capacitors because they are the best choice in preventing leakage current. When polarized capacitors are used, the positive side of the capacitor faces the amplifier input in most applications. The input DC level is held at $V_{DD} / 2$, typically higher than the source DC level. Confirming the capacitor polarity in the application is important.

7.2.1.2.4 Band-Pass Filter (R_b , C_b , and C_F)

Having signal filtering beyond the one-pole high-pass filter formed by the combination of C_1 and R_1 can be desirable. A low-pass filter can be added by placing a capacitor (C_F) between the inputs and outputs, forming a band-pass filter.

An example of when this technique might be used would be in an application where the desirable pass-band range is between 100 Hz and 10 kHz, with a gain of 4 V/V. Equation 22 to Equation 29 allow the proper values of C_F and C_1 to be determined.

7.2.1.2.4.1 Step 1: Low-Pass Filter

$$f_{c(LPF)} = \frac{1}{2\pi R_F C_F} \quad (22)$$

$$f_{c(LPF)} = \frac{1}{2\pi 40\text{k}\Omega C_F} \quad (23)$$

Therefore,

$$C_F = \frac{1}{2\pi 40\text{ k}\Omega f_{c(LPF)}} \quad (24)$$

Substituting 10 kHz for $f_{c(LPF)}$ and solving for C_F :

$$C_F = 398\text{ pF} \quad (25)$$

7.2.1.2.4.2 Step 2: High-Pass Filter

$$f_{c(HPF)} = \frac{1}{2\pi R_1 C_1} \quad (26)$$

Because the application in this case requires a gain of 4 V/V, R_1 must be set to 10 k Ω .

Substituting R_1 into Equation 26.

$$f_{c(HPF)} = \frac{1}{2\pi 10\text{ k}\Omega C_1} \quad (27)$$

Therefore,

$$C_1 = \frac{1}{2\pi \cdot 10 \text{ k}\Omega \cdot f_{c(\text{HPF})}} \quad (28)$$

Substituting 100 Hz for $f_{c(\text{HPF})}$ and solving for C_1 :

$$C_1 = 0.16 \text{ }\mu\text{F} \quad (29)$$

At this point, a first-order band-pass filter has been created with the low-frequency cutoff set to 100 Hz and the high-frequency cutoff set to 10 kHz.

The process can be taken a step further by creating a second-order high-pass filter. This is accomplished by placing a resistor (R_a) and capacitor (C_a) in the input path. R_a must be at least 10 times smaller than R_1 ; otherwise its value has a noticeable effect on the gain, as R_a and R_1 are in series.

7.2.1.2.4.3 Step 3: Additional Low-Pass Filter

R_a must be at least ten-times smaller than R_1 . Set $R_a = 1 \text{ k}\Omega$

$$f_{c(\text{LPF})} = \frac{1}{2\pi R_a C_a} \quad (30)$$

Therefore,

$$C_a = \frac{1}{2\pi \cdot 1 \text{ k}\Omega \cdot f_{c(\text{LPF})}} \quad (31)$$

Substituting 10 kHz for $f_{c(\text{LPF})}$ and solving for C_a :

$$C_a = 160 \text{ pF} \quad (32)$$

Figure 7-3 is a bode plot for the band-pass filter in the previous example. Figure 7-8 shows how to configure the TPA6211A1-Q1 device as a band-pass filter.

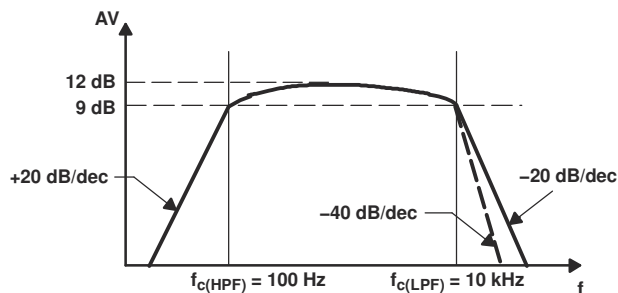

Figure 7-3. Bode Plot

7.2.1.2.5 Decoupling Capacitor (C_S)

The TPA6211A1-Q1 device is a high-performance CMOS audio amplifier that requires adequate power supply decoupling to ensure the output total harmonic distortion (THD) is as low as possible. Power-supply decoupling also prevents oscillations for long lead lengths between the amplifier and the speaker. For higher frequency transients, spikes, or digital hash on the line, a good low equivalent-series-resistance (ESR) ceramic capacitor, typically 0.1 μF to 1 μF , placed as close as possible to the device V_{DD} lead works best. For filtering lower frequency noise signals, a 10- μF or greater capacitor placed near the audio power amplifier also helps, but is not required in most applications because of the high PSRR of this device.

7.2.1.2.6 Using Low-ESR Capacitors

Low-ESR capacitors are recommended throughout this applications section. A real (as opposed to ideal) capacitor can be modeled simply as a resistor in series with an ideal capacitor. The voltage drop across this resistor minimizes the beneficial effects of the capacitor in the circuit. The lower the equivalent value of this resistance the more the real capacitor behaves like an ideal capacitor.

7.2.1.3 Application Curves

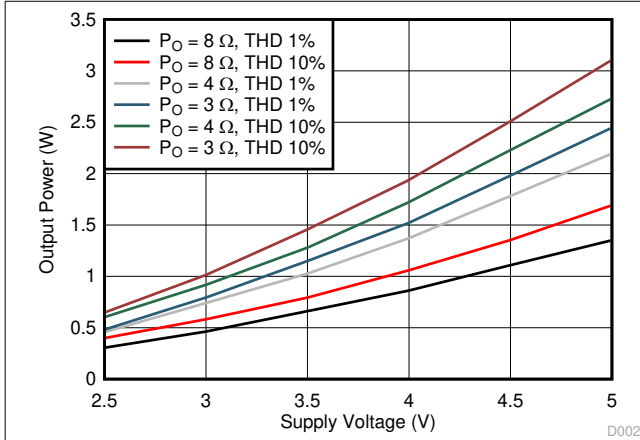

Figure 7-4. Output Power vs Supply Voltage

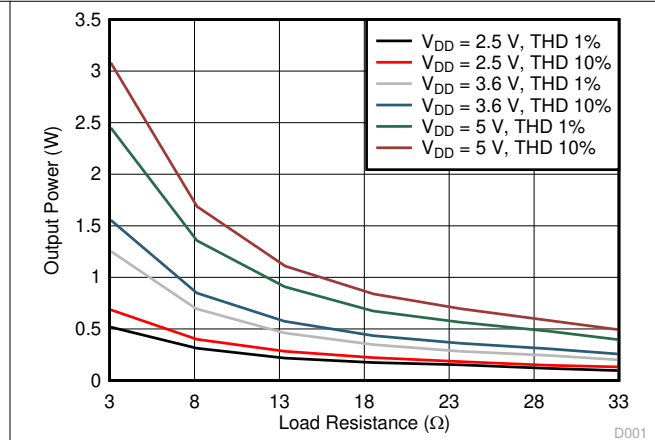
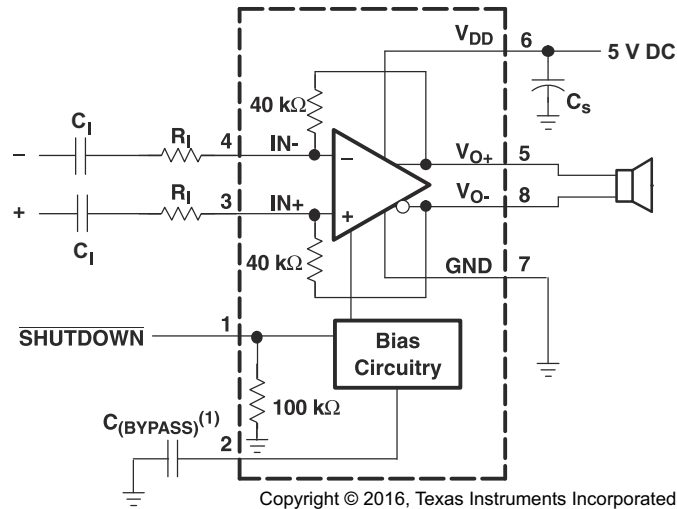

Figure 7-5. Output Power vs Load Resistance

7.2.2 Other Application Circuits

Figure 7-6, Figure 7-7, and Figure 7-8 show example circuits using the TPA6211A1-Q1 device.



A. $C_{(BYPASS)}$ is optional

Figure 7-6. Differential Input Application Schematic Optimized With Input Capacitors

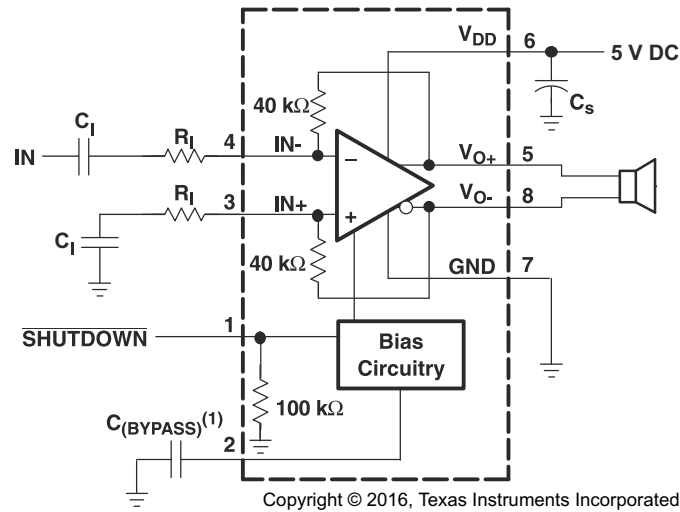

A. $C_{(BYPASS)}$ is optional

Figure 7-7. Single-Ended Input Application Schematic

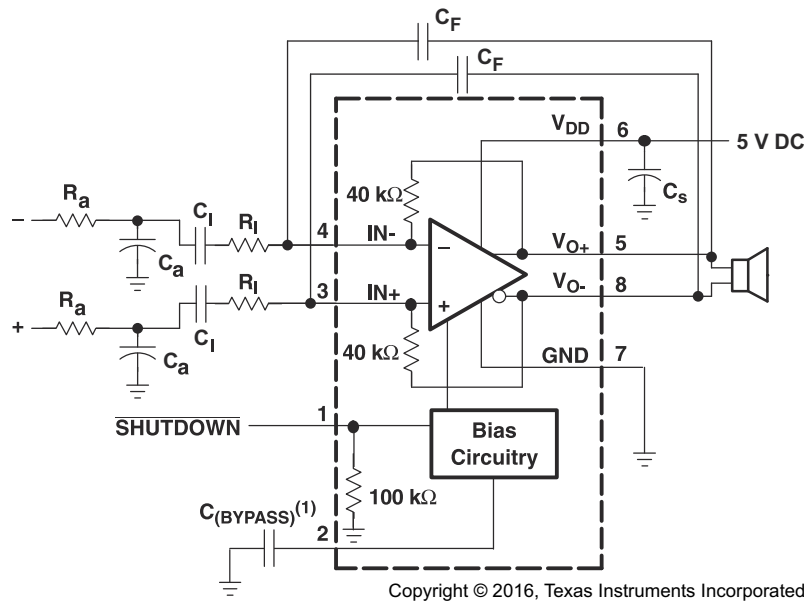

A. $C_{(BYPASS)}$ is optional

Figure 7-8. Differential Input Application Schematic With Input Bandpass Filter

7.3 Power Supply Recommendations

The TPA6211A1-Q1 device is designed to operate from an input voltage supply range between 2.5 V and 5.5 V. Therefore, the output voltage range of power supply must be within this range and well regulated. The current capability of upper power should not exceed the maximum current limit of the power switch.

7.3.1 Power Supply Decoupling Capacitor

The TPA6211A1-Q1 device requires adequate power supply decoupling to ensure a high efficiency operation with low total harmonic distortion (THD). Place a low equivalent series resistance (ESR) ceramic capacitor, typically 0.1 μF , as close as possible of the V_{DD} pin. This choice of capacitor and placement helps with higher frequency transients, spikes, or digital hash on the line. TI recommends placing a 2.2- μF to 10- μF capacitor on the V_{DD} supply trace. This larger capacitor acts as a charge reservoir, providing energy faster than the board supply, thus helping to prevent any droop in the supply voltage.

7.4 Layout

7.4.1 Layout Guidelines

Place all the external components close to the TPA6211A1-Q1 device. The input resistors need to be close to the device input pins so noise does not couple on the high impedance nodes between the input resistors and the input amplifier of the device. Placing the decoupling capacitors, C_S and C_{BYPASS} , close to the TPA6211A1-Q1 device is important for the efficiency of the amplifier. Any resistance or inductance in the trace between the device and the capacitor can cause a loss in efficiency.

7.4.2 Layout Example

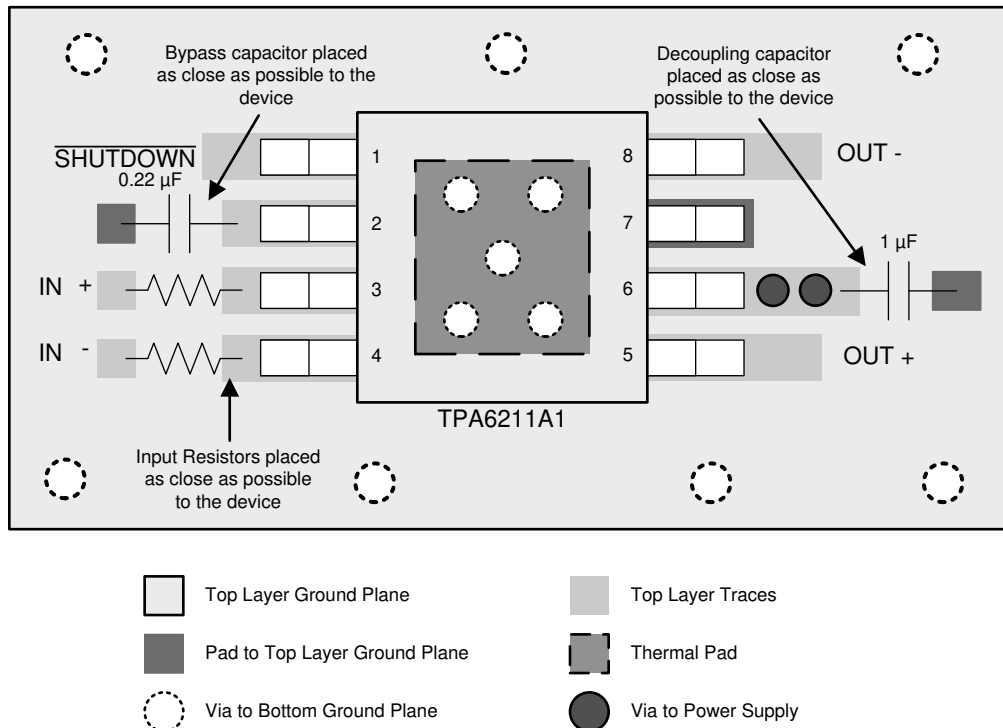

Figure 7-9. TPA6211A1-Q1 8-Pin HVSSOP (DGN) Board Layout

8 Device and Documentation Support

8.1 Receiving Notification of Documentation Updates

To receive notification of documentation updates, navigate to the device product folder on ti.com. In the upper right corner, click on *Alert me* to register and receive a weekly digest of any product information that has changed. For change details, review the revision history included in any revised document.

8.2 Support Resources

TI E2E™ support forums are an engineer's go-to source for fast, verified answers and design help — straight from the experts. Search existing answers or ask your own question to get the quick design help you need.

Linked content is provided "AS IS" by the respective contributors. They do not constitute TI specifications and do not necessarily reflect TI's views; see TI's [Terms of Use](#).

8.3 Trademarks

TI E2E™ is a trademark of Texas Instruments.

All trademarks are the property of their respective owners.

8.4 Electrostatic Discharge Caution



This integrated circuit can be damaged by ESD. Texas Instruments recommends that all integrated circuits be handled with appropriate precautions. Failure to observe proper handling and installation procedures can cause damage.

ESD damage can range from subtle performance degradation to complete device failure. Precision integrated circuits may be more susceptible to damage because very small parametric changes could cause the device not to meet its published specifications.

8.5 Glossary

[TI Glossary](#) This glossary lists and explains terms, acronyms, and definitions.

9 Revision History

NOTE: Page numbers for previous revisions may differ from page numbers in the current version.

Changes from Revision F (February 2024) to Revision G (May 2024) Page

- Changed the *ESD Ratings* for CDM to $\pm 1000V$4

Changes from Revision E (August 2019) to Revision F (February 2024) Page

- Changed *Device HBM ESD classification level* in the Feature: Qualified for automotive applications.....1
- Changed the *ESD Ratings* for HBM to $\pm 2000V$4

Changes from Revision D (August 2019) to Revision E (August 2019) Page

- Changed packaging to HVSSOP.....1
- Changed packaging to HVSSOP.....4
- Changed packaging to HVSSOP.....25

Changes from Revision C (August 2016) to Revision D (August 2019) Page

- Deleted *AEC-Q100* from the Feature: Qualified for automotive applications.....1
- Deleted Feature: Temperature Grade 2.....1
- Changed the *ESD Ratings* table.....4

Changes from Revision B (January 2014) to Revision C (August 2016)	Page
• Added <i>Device Information</i> table, <i>ESD Ratings</i> table, <i>Feature Description</i> section, <i>Device Functional Modes</i> section, <i>Application and Implementation</i> section, <i>Power Supply Recommendations</i> section, <i>Layout</i> section, <i>Device and Documentation Support</i> section, and <i>Mechanical, Packaging, and Orderable Information</i> section.	1
• Added missing Max Ambient Temperature values to Table 6-1	13
• Changed 45.9 to 71.7, 1.27 to 1.25, and 91.7 to 60 in Equation 13	13

Changes from Revision A (November 2013) to Revision B (January 2014)	Page
• Added three new equations to the <i>DIFFERENTIAL OUTPUT VERSUS SINGLE-ENDED OUTPUT</i> section in order to show difference between single-ended and differential output.....	17

Changes from Revision * (June 2011) to Revision A (November 2013)	Page
• Deleted <i>Designed for Wireless or Cellular Handsets and PDAs</i> from <i>Features</i> list.....	1
• Deleted <i>Ordering Information</i> table.....	3
• Changed reference from "equation 6" to Equation 26 in the <i>High-Pass Filter</i> section.....	21

10 Mechanical, Packaging, and Orderable Information

The following pages include mechanical, packaging, and orderable information. This information is the most current data available for the designated devices. This data is subject to change without notice and revision of this document. For browser-based versions of this data sheet, refer to the left-hand navigation.

PACKAGING INFORMATION

Orderable Device	Status (1)	Package Type	Package Drawing	Pins	Package Qty	Eco Plan (2)	Lead finish/ Ball material (6)	MSL Peak Temp (3)	Op Temp (°C)	Device Marking (4/5)	Samples
TPA6211A1TDGNRQ1	ACTIVE	HVSSOP	DGN	8	2500	RoHS & Green	NIPDAU	Level-3-260C-168 HR	-40 to 105	6211Q	Samples

(1) The marketing status values are defined as follows:

ACTIVE: Product device recommended for new designs.

LIFEBUY: TI has announced that the device will be discontinued, and a lifetime-buy period is in effect.

NRND: Not recommended for new designs. Device is in production to support existing customers, but TI does not recommend using this part in a new design.

PREVIEW: Device has been announced but is not in production. Samples may or may not be available.

OBSOLETE: TI has discontinued the production of the device.

(2) **RoHS:** TI defines "RoHS" to mean semiconductor products that are compliant with the current EU RoHS requirements for all 10 RoHS substances, including the requirement that RoHS substance do not exceed 0.1% by weight in homogeneous materials. Where designed to be soldered at high temperatures, "RoHS" products are suitable for use in specified lead-free processes. TI may reference these types of products as "Pb-Free".

RoHS Exempt: TI defines "RoHS Exempt" to mean products that contain lead but are compliant with EU RoHS pursuant to a specific EU RoHS exemption.

Green: TI defines "Green" to mean the content of Chlorine (Cl) and Bromine (Br) based flame retardants meet JS709B low halogen requirements of <=1000ppm threshold. Antimony trioxide based flame retardants must also meet the <=1000ppm threshold requirement.

(3) MSL, Peak Temp. - The Moisture Sensitivity Level rating according to the JEDEC industry standard classifications, and peak solder temperature.

(4) There may be additional marking, which relates to the logo, the lot trace code information, or the environmental category on the device.

(5) Multiple Device Markings will be inside parentheses. Only one Device Marking contained in parentheses and separated by a "~" will appear on a device. If a line is indented then it is a continuation of the previous line and the two combined represent the entire Device Marking for that device.

(6) Lead finish/Ball material - Orderable Devices may have multiple material finish options. Finish options are separated by a vertical ruled line. Lead finish/Ball material values may wrap to two lines if the finish value exceeds the maximum column width.

Important Information and Disclaimer:The information provided on this page represents TI's knowledge and belief as of the date that it is provided. TI bases its knowledge and belief on information provided by third parties, and makes no representation or warranty as to the accuracy of such information. Efforts are underway to better integrate information from third parties. TI has taken and continues to take reasonable steps to provide representative and accurate information but may not have conducted destructive testing or chemical analysis on incoming materials and chemicals. TI and TI suppliers consider certain information to be proprietary, and thus CAS numbers and other limited information may not be available for release.

In no event shall TI's liability arising out of such information exceed the total purchase price of the TI part(s) at issue in this document sold by TI to Customer on an annual basis.

OTHER QUALIFIED VERSIONS OF TPA6211A1-Q1 :

- Catalog : [TPA6211A1](#)

NOTE: Qualified Version Definitions:

- Catalog - TI's standard catalog product

TAPE AND REEL INFORMATION

QUADRANT ASSIGNMENTS FOR PIN 1 ORIENTATION IN TAPE

*All dimensions are nominal

Device	Package Type	Package Drawing	Pins	SPQ	Reel Diameter (mm)	Reel Width W1 (mm)	A0 (mm)	B0 (mm)	K0 (mm)	P1 (mm)	W (mm)	Pin1 Quadrant
TPA6211A1TDGNRQ1	HVSSOP	DGN	8	2500	330.0	12.4	5.3	3.4	1.4	8.0	12.0	Q1

TAPE AND REEL BOX DIMENSIONS

*All dimensions are nominal

Device	Package Type	Package Drawing	Pins	SPQ	Length (mm)	Width (mm)	Height (mm)
TPA6211A1TDGNRQ1	HVSSOP	DGN	8	2500	346.0	346.0	29.0

GENERIC PACKAGE VIEW

DGN 8

PowerPAD VSSOP - 1.1 mm max height

3 x 3, 0.65 mm pitch

SMALL OUTLINE PACKAGE

This image is a representation of the package family, actual package may vary.
Refer to the product data sheet for package details.

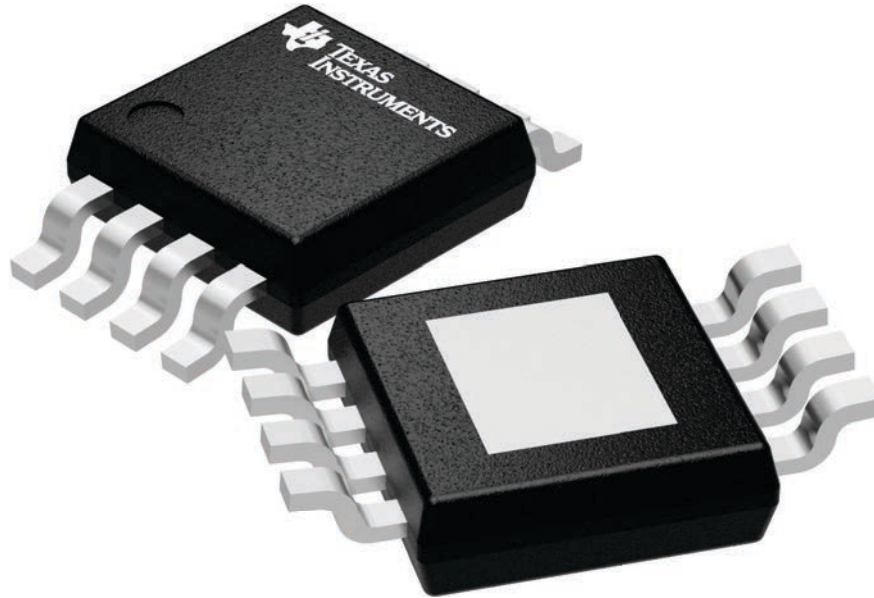

4225482/A

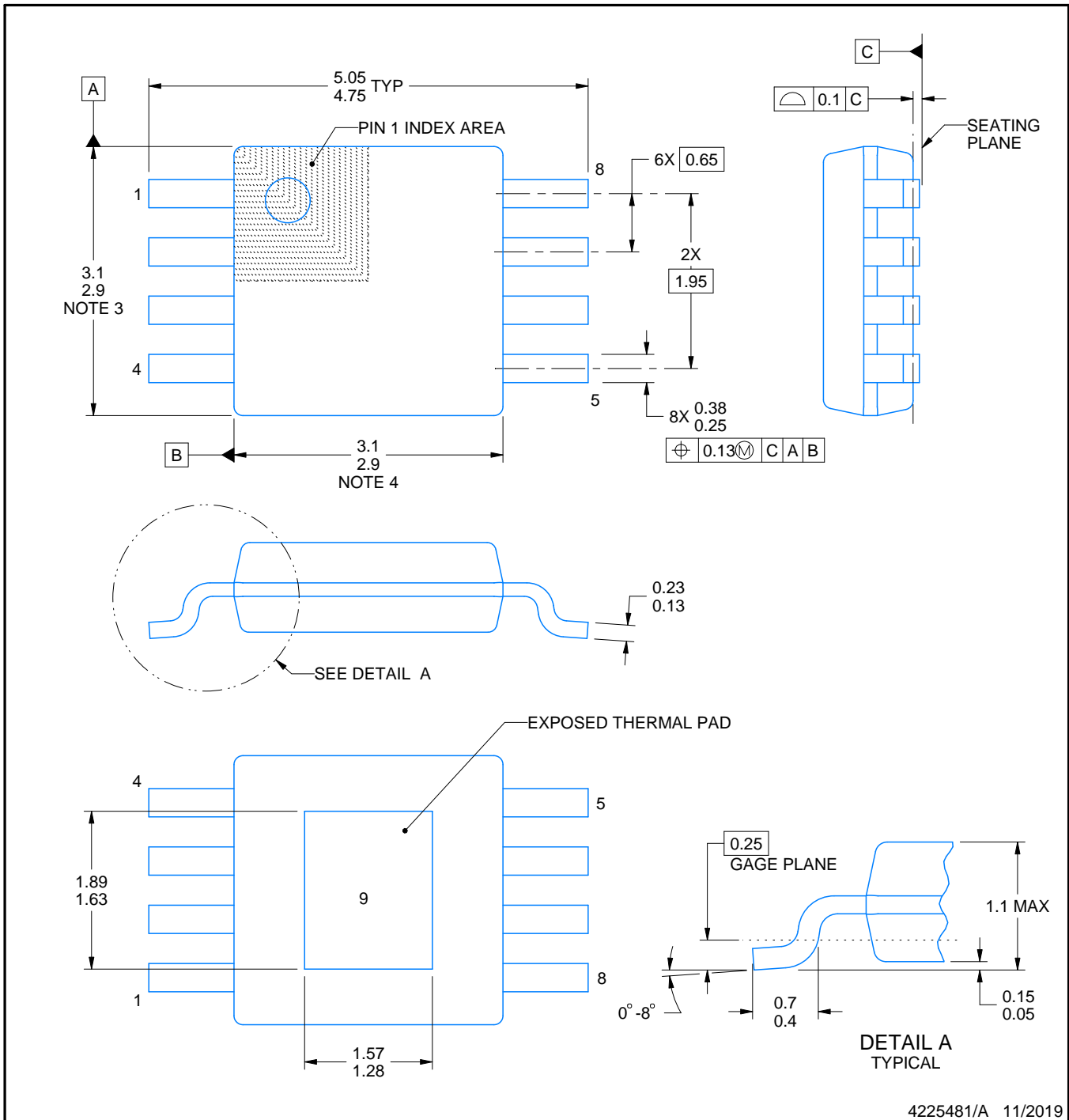

4225481/A 11/2019

PowerPAD is a trademark of Texas Instruments.

NOTES:

1. All linear dimensions are in millimeters. Any dimensions in parenthesis are for reference only. Dimensioning and tolerancing per ASME Y14.5M.
2. This drawing is subject to change without notice.
3. This dimension does not include mold flash, protrusions, or gate burrs. Mold flash, protrusions, or gate burrs shall not exceed 0.15 mm per side.
4. This dimension does not include interlead flash. Interlead flash shall not exceed 0.25 mm per side.
5. Reference JEDEC registration MO-187.

EXAMPLE BOARD LAYOUT

DGN0008D

PowerPAD™ VSSOP - 1.1 mm max height

SMALL OUTLINE PACKAGE

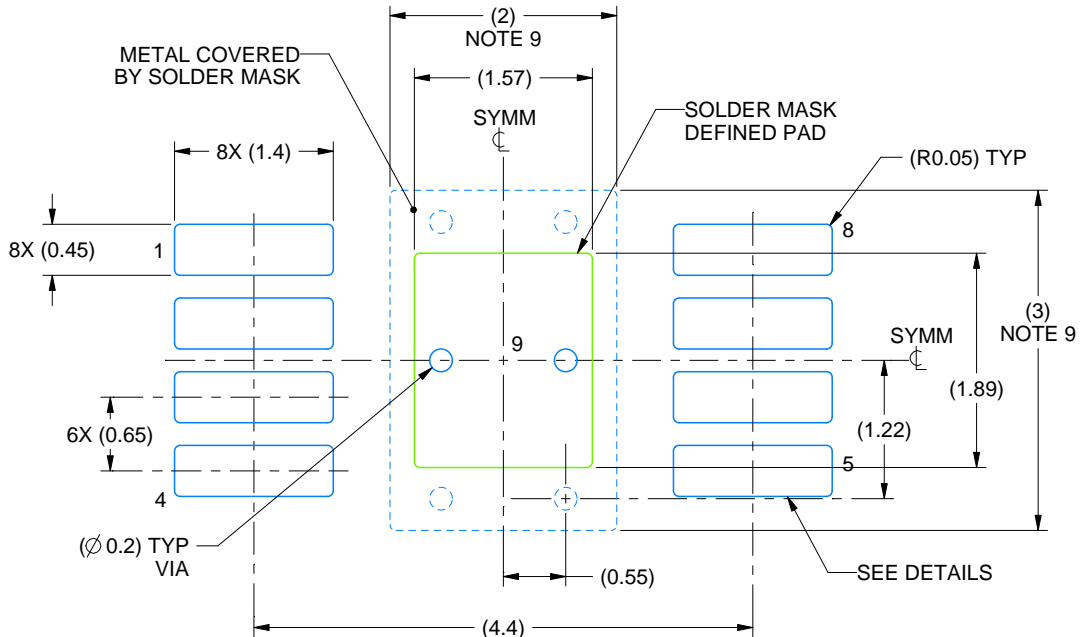

LAND PATTERN EXAMPLE
EXPOSED METAL SHOWN
SCALE: 15X

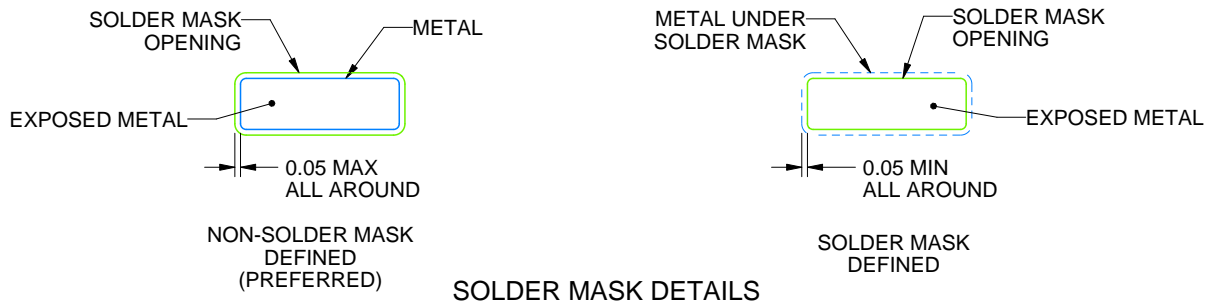

4225481/A 11/2019

NOTES: (continued)

6. Publication IPC-7351 may have alternate designs.
7. Solder mask tolerances between and around signal pads can vary based on board fabrication site.
8. Vias are optional depending on application, refer to device data sheet. If any vias are implemented, refer to their locations shown on this view. It is recommended that vias under paste be filled, plugged or tented.
9. Size of metal pad may vary due to creepage requirement.

EXAMPLE STENCIL DESIGN

DGN0008D

PowerPAD™ VSSOP - 1.1 mm max height

SMALL OUTLINE PACKAGE

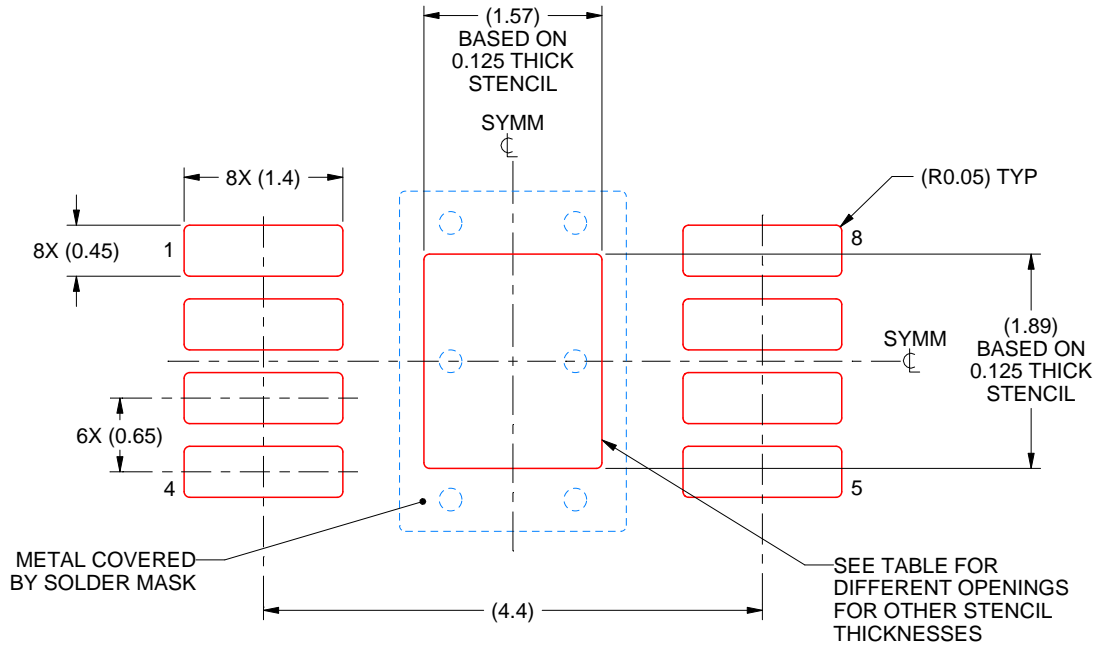

SOLDER PASTE EXAMPLE
EXPOSED PAD 9:
100% PRINTED SOLDER COVERAGE BY AREA
SCALE: 15X

STENCIL THICKNESS	SOLDER STENCIL OPENING
0.1	1.76 X 2.11
0.125	1.57 X 1.89 (SHOWN)
0.15	1.43 X 1.73
0.175	1.33 X 1.60

4225481/A 11/2019

NOTES: (continued)

10. Laser cutting apertures with trapezoidal walls and rounded corners may offer better paste release. IPC-7525 may have alternate design recommendations.
11. Board assembly site may have different recommendations for stencil design.

IMPORTANT NOTICE AND DISCLAIMER

TI PROVIDES TECHNICAL AND RELIABILITY DATA (INCLUDING DATA SHEETS), DESIGN RESOURCES (INCLUDING REFERENCE DESIGNS), APPLICATION OR OTHER DESIGN ADVICE, WEB TOOLS, SAFETY INFORMATION, AND OTHER RESOURCES "AS IS" AND WITH ALL FAULTS, AND DISCLAIMS ALL WARRANTIES, EXPRESS AND IMPLIED, INCLUDING WITHOUT LIMITATION ANY IMPLIED WARRANTIES OF MERCHANTABILITY, FITNESS FOR A PARTICULAR PURPOSE OR NON-INFRINGEMENT OF THIRD PARTY INTELLECTUAL PROPERTY RIGHTS.

These resources are intended for skilled developers designing with TI products. You are solely responsible for (1) selecting the appropriate TI products for your application, (2) designing, validating and testing your application, and (3) ensuring your application meets applicable standards, and any other safety, security, regulatory or other requirements.

These resources are subject to change without notice. TI grants you permission to use these resources only for development of an application that uses the TI products described in the resource. Other reproduction and display of these resources is prohibited. No license is granted to any other TI intellectual property right or to any third party intellectual property right. TI disclaims responsibility for, and you will fully indemnify TI and its representatives against, any claims, damages, costs, losses, and liabilities arising out of your use of these resources.

TI's products are provided subject to [TI's Terms of Sale](#) or other applicable terms available either on [ti.com](https://www.ti.com) or provided in conjunction with such TI products. TI's provision of these resources does not expand or otherwise alter TI's applicable warranties or warranty disclaimers for TI products.

TI objects to and rejects any additional or different terms you may have proposed.

Mailing Address: Texas Instruments, Post Office Box 655303, Dallas, Texas 75265
Copyright © 2024, Texas Instruments Incorporated

Looking for pricing, stock, or lifecycle information?

Click below to explore more details on WIN SOURCE:

 [View TPA6211A1TDGNRQ1 on WIN SOURCE](#)

 [Texas Instruments](#) Information

Optimize Your Supply Chain with WIN SOURCE Solutions

-  Global Sourcing Solution
-  Obsolete Management
-  Cost Control Management
-  Shortage Management
-  Alternative Solution
-  Excess Inventory Management