



**THE DATASHEET OF
TPA6020A2RGWT**





2.8-W STEREO FULLY DIFFERENTIAL AUDIO POWER AMPLIFIER

FEATURES

- Ideal for Notebook PCs
- Fully Differential Architecture and High PSRR (-80 dB) Provide Excellent RF Rectification Immunity
- 2.8 W Into 3 Ω From a 5-V Supply at THD = 10% (Typical)
- Very Low Crosstalk:
 - -100 dB Typical at 5 V, 3 Ω
- 2.5-V to 5.5-V Operating Range
- Low Supply Current:
 - 8 mA Typical at 5 V
 - Shutdown Current: 80-nA Typical
- Fast Startup (27 ms) With Minimal Pop
- Internal Feedback Resistors Reduce Component Count
- Thermally Enhanced QFN Packaging

APPLICATIONS

- Notebook PCs
- LCD TVs

DESCRIPTION

The TPA6020A2 is a 2.8-W stereo bridge-tied load (BTL) amplifier designed to drive stereo speakers with at least 3-Ω impedance. The device operates from 2.5 V to 5.5 V, drawing only 8 mA of quiescent supply current. The feedback resistors are internal, allowing the gain to be set with only two input resistors per channel. The amplifier's fully differential architecture performs with -80 dB of power supply rejection from 20 Hz to 2 kHz, improved RF rectification immunity, small PCB area, and a fast startup time with minimal pop, making the TPA6020A2 ideal for notebook PC applications.

APPLICATION CIRCUIT

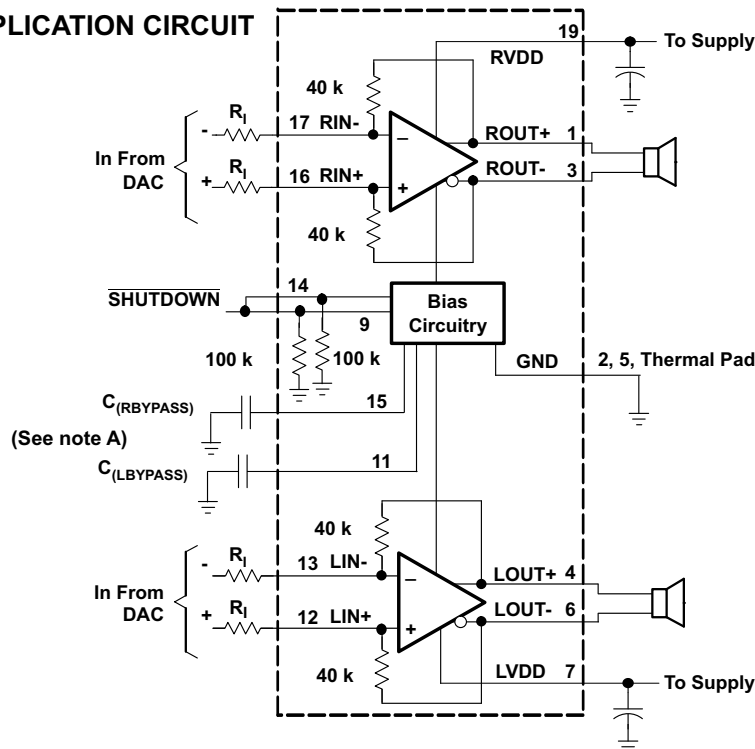

A. $C_{(LBYPASS)}$ and $C_{(RBYPASS)}$ are optional.

20-PIN QFN (RGW) PACKAGE (TOP VIEW)

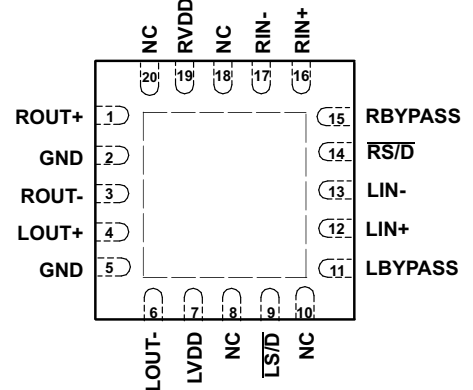

Please be aware that an important notice concerning availability, standard warranty, and use in critical applications of Texas Instruments semiconductor products and disclaimers thereto appears at the end of this data sheet.



These devices have limited built-in ESD protection. The leads should be shorted together or the device placed in conductive foam during storage or handling to prevent electrostatic damage to the MOS gates.

ORDERING INFORMATION

T _A	PACKAGED DEVICES ⁽¹⁾⁽²⁾	EVALUATION MODULES
	QFN (RGW)	
-40°C to 85°C	TPA6020A2RGW	TPA6020A2EVM

- (1) The RGW is available taped and reeled. To order taped and reeled parts, add the suffix R to the part number (TPA6020A2RGWR).
- (2) For the most current package and ordering information, see the Package Option Addendum at the end of this document, or see the TI website at www.ti.com.

ABSOLUTE MAXIMUM RATINGS

over operating free-air temperature range unless otherwise noted⁽¹⁾

		UNIT
V _{DD}	Supply voltage	-0.3 V to 6 V
V _I	Input voltage	-0.3 V to V _{DD} + 0.3 V
	Continuous total power dissipation	See Dissipation Rating Table
T _A	Operating free-air temperature	-40°C to 85°C
T _J	Junction temperature	-40°C to 150°C
T _{stg}	Storage temperature	-65°C to 85°C
	Lead temperature 1,6 mm (1/16 Inch) from case for 10 seconds	260°C
Electrostatic discharge	Human body model ⁽²⁾ (all pins)	±2 kV
	Charged-device model ⁽³⁾ (all pins)	±500 V

- (1) Stresses beyond those listed under "absolute maximum ratings" may cause permanent damage to the device. These are stress ratings only, and functional operation of the device at these or any other conditions beyond those indicated under "recommended operating conditions" is not implied. Exposure to absolute-maximum-rated conditions for extended periods may affect device reliability.
- (2) In accordance with JEDEC Standard 22, Test Method A114-B.
- (3) In accordance with JEDEC Standard 22, Test Method C101-A

PACKAGE DISSIPATION RATINGS

PACKAGE	T _A 25°C POWER RATING	DERATING FACTOR ⁽¹⁾	T _A = 70°C POWER RATING	T _A = 85°C POWER RATING
RGW	2.99 W	23.98 mW/°C	1.92 W	1.56 W

- (1) Derating factor based on high-k board layout.

RECOMMENDED OPERATION CONDITIONS

		MIN	TYP	MAX	UNIT
V _{DD}	Supply voltage	2.5		5.5	V
V _{IH}	High-level input voltage	SHUTDOWN	1.55		V
V _{IL}	Low-level input voltage	SHUTDOWN		0.5	V
T _A	Operating free-air temperature	-40		85	°C

ELECTRICAL CHARACTERISTICS
 $T_A = 25^\circ\text{C}$

PARAMETER		TEST CONDITIONS	MIN	TYP	MAX	UNIT
V_{OS}	Output offset voltage (measured differentially)	$V_I = 0\text{ V}$ differential, Gain = 1 V/V, $V_{DD} = 5.5\text{ V}$	-9	0.3	9	mV
PSRR	Power supply rejection ratio	$V_{DD} = 2.5\text{ V}$ to 5.5 V		-85		dB
V_{IC}	Common-mode input range	$V_{DD} = 2.5\text{ V}$ to 5.5 V	0.5		$V_{DD}-0.8$	V
CMRR	Common-mode rejection ratio	$V_{DD} = 5.5\text{ V}$, $V_{IC} = 0.5\text{ V}$ to 4.7 V		-63		dB
		$V_{DD} = 2.5\text{ V}$, $V_{IC} = 0.5\text{ V}$ to 1.7 V		-63		
Low-output swing		$R_L = 3\ \Omega$, $V_{IN+} = V_{DD}$, $V_{IN-} = 0\text{ V}$, Gain = 1 V/V, $V_{IN-} = 0\text{ V}$ or $V_{IN-} = V_{DD}$	$V_{DD} = 5.5\text{ V}$	0.55		V
			$V_{DD} = 3.6\text{ V}$	0.42		
			$V_{DD} = 2.5\text{ V}$	0.34	0.4	
High-output swing		$R_L = 3\ \Omega$, $V_{IN+} = V_{DD}$, $V_{IN-} = V_{DD}$, Gain = 1 V/V, $V_{IN-} = 0\text{ V}$ or $V_{IN+} = 0\text{ V}$	$V_{DD} = 5.5\text{ V}$	4.9		V
			$V_{DD} = 3.6\text{ V}$	3.1		
			$V_{DD} = 2.5\text{ V}$	1.9	2.1	
$ I_{IH} $	High-level input current, shutdown	$V_{DD} = 5.5\text{ V}$, $V_I = 5.8\text{ V}$		58	100	μA
$ I_{IL} $	Low-level input current, shutdown	$V_{DD} = 5.5\text{ V}$, $V_I = -0.3\text{ V}$		3	100	μA
I_Q	Quiescent current	$V_{DD} = 2.5\text{ V}$ to 5.5 V, no load		8	9.8	mA
$I_{(SD)}$	Supply current	$V(\text{SHUTDOWN}) \leq 0.5\text{ V}$, $V_{DD} = 2.5\text{ V}$ to 5.5 V, $R_L = 3\ \Omega$		0.08	1	μA
Gain		$R_L = 3\ \Omega$	$\frac{38\text{ k}\Omega}{R_1}$	$\frac{40\text{ k}\Omega}{R_1}$	$\frac{42\text{ k}\Omega}{R_1}$	V/V
	Resistance from shutdown to GND			100		k Ω

OPERATING CHARACTERISTICS

T_A = 25°C, Gain = 2 V/V

PARAMETER		TEST CONDITIONS		MIN	TYP	MAX	UNIT
P _O	Output power	THD + N= 1%, f = 1 kHz, R _L = 3 Ω	V _{DD} = 5 V		2.15		W
			V _{DD} = 3.6 V		1.08		
			V _{DD} = 2.5 V		0.43		
		THD + N= 1%, f = 1 kHz, R _L = 4 Ω	V _{DD} = 5 V		1.94		
			V _{DD} = 3.6 V		1.00		
			V _{DD} = 2.5 V		0.41		
		THD + N= 1%, f = 1 kHz, R _L = 8 Ω	V _{DD} = 5 V		1.27		
			V _{DD} = 3.6 V		0.65		
			V _{DD} = 2.5 V		0.29		
THD+N	Total harmonic distortion plus noise	f = 1 kHz, R _L = 3 Ω	P _O = 2 W	V _{DD} = 5 V		0.09%	
			P _O = 1 W	V _{DD} = 3.6 V		0.20%	
			P _O = 300 mW	V _{DD} = 2.5 V		0.08%	
		f = 1 kHz, R _L = 4 Ω	P _O = 1.8 W	V _{DD} = 5 V		0.08%	
			P _O = 0.7 W	V _{DD} = 3.6 V		0.07%	
			P _O = 300 mW	V _{DD} = 2.5 V		0.12%	
		f = 1 kHz, R _L = 8 Ω	P _O = 1 W	V _{DD} = 5 V		0.05%	
			P _O = 0.5 W	V _{DD} = 3.6 V		0.06%	
			P _O = 200 mW	V _{DD} = 2.5 V		0.06%	
k _{SVR}	Supply ripple rejection ratio	V _{DD} = 3.6 V, Inputs ac-grounded with C ₁ = 2 μF, V _(RIPPLE) = 200 mV _{pp}	f = 217 Hz		-80		dB
			f = 20 Hz to 20 kHz		-70		
	Crosstalk	V _{DD} = 5 V, R _L = 3 Ω, f = 20 Hz to 20 kHz, P _o = 1 W			-100		dB
SNR	Signal-to-noise ratio	V _{DD} = 5 V, P _O = 2 W, R _L = 3 Ω, Gain = 1 V/V			104		dB
V _n	Output voltage noise	V _{DD} = 3.6 V, f = 20 Hz to 20 kHz, Gain = 1 V/V Inputs ac grounded with C ₁ = 0.22 μF	No weighting		15		μV _{RMS}
			A weighting		12		
CMRR	Common-mode rejection ratio	V _{DD} = 3.6 V, V _{IC} = 200 mV _{pp}	f = 217 Hz		-65		dB
Z _I	Input impedance			38	40	42	kΩ
	Start-up time from shutdown	V _{DD} = 3.6 V, No C _{BYPASS}			4		μs
		V _{DD} = 3.6 V, C _{BYPASS} = 0.1 μF			27		ms

Terminal Functions

TERMINAL NAME NO.		I/O	DESCRIPTION
ROUT+	1	O	Right channel positive BTL output
GND	2,5	I	High current ground
ROUT-	3	O	Right channel negative BTL output
LOUT+	4	O	Left channel positive BTL output
LOUT-	6	O	Left channel negative BTL output
LVDD	7	I	Left channel power supply. Must be tied to RVDD for stereo operation.
NC	8, 10, 18, 20	–	No internal connection.
$\overline{\text{LS/D}}$	9	I	Left channel shutdown terminal (active low logic)
LBYPASS	11	–	Left channel mid-supply voltage. Adding a bypass capacitor improves PSRR
LIN+	12	I	Left channel positive differential input
LIN-	13	I	Left channel negative differential input
$\overline{\text{RS/D}}$	14	–	Right channel shutdown terminal (active low logic)
RBYPASS	15	–	Right channel mid-supply voltage. Adding a bypass capacitor improves PSRR
RIN+	16	I	Right channel positive differential input
RIN-	17	I	Right channel negative differential input
RVDD	19	I	Power supply
Thermal Pad	–	–	Connect to ground. Thermal pad must be soldered down in all applications to properly secure device on the PCB.

TYPICAL CHARACTERISTICS

Table of Graphs

			FIGURE
P _O	Output power	vs Supply voltage	1
		vs Load resistance	2
P _D	Power dissipation	vs Output power	3, 4
		vs Frequency	5, 6, 7
THD+N	Total harmonic distortion + noise	vs Output power	8, 9, 10, 11, 12, 13
		vs Frequency	14
K _{SVR}	Supply voltage rejection ratio	vs Frequency	15, 16, 17, 18
	GSM power supply rejection	vs Time	19
	GSM power supply rejection	vs Frequency	20
CMRR	Common-mode rejection ratio	vs Frequency	21
		vs Common-mode input voltage	22
	Closed-loop gain/phase	vs Frequency	23
	Open-loop gain/phase	vs Frequency	24
	Start-up time	vs Bypass capacitor	25

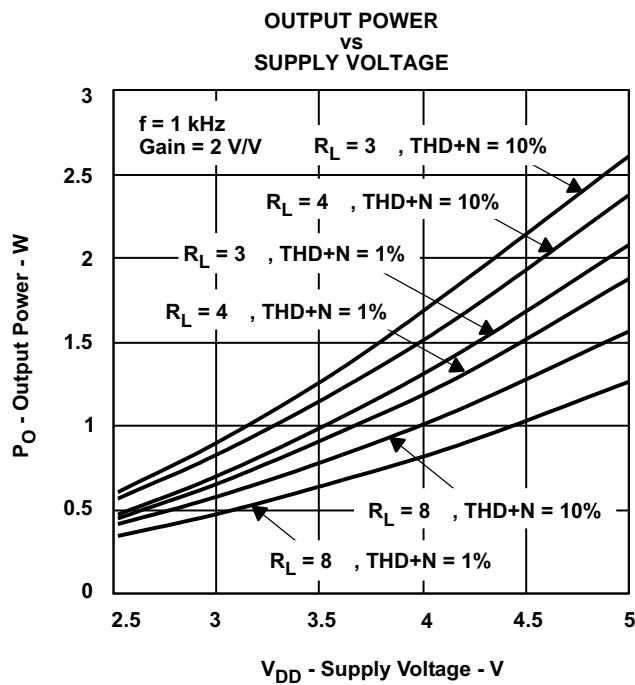

Figure 1.

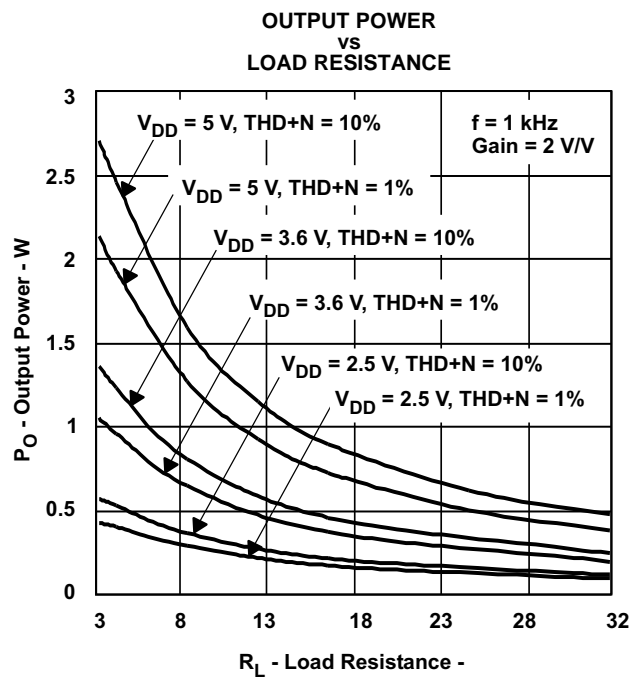

Figure 2.

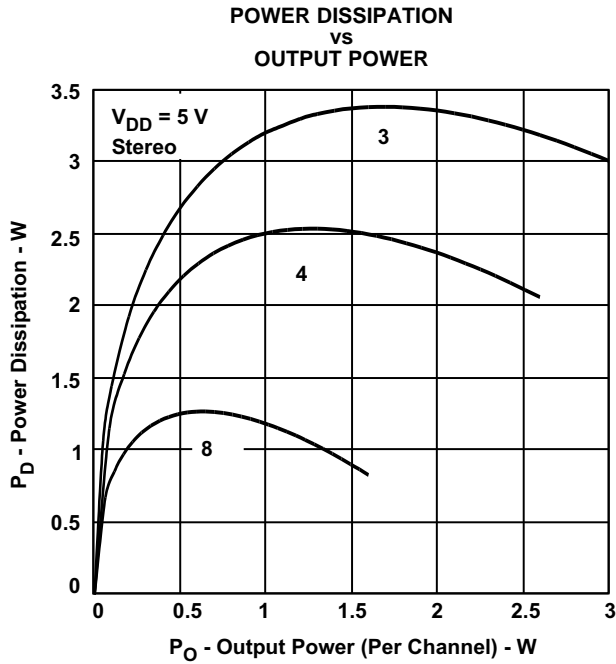

Figure 3.

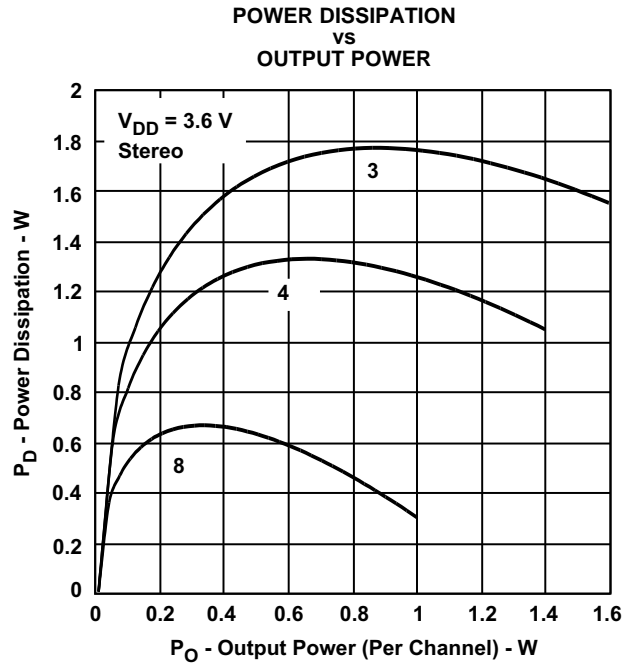

Figure 4.

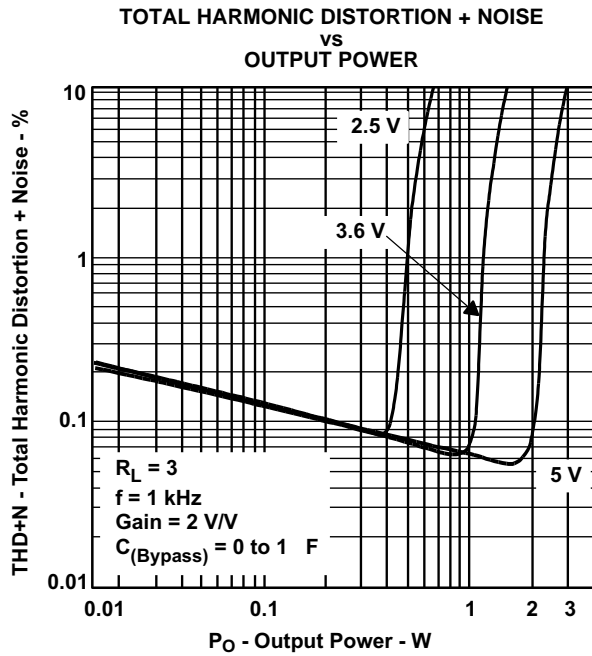

Figure 5.

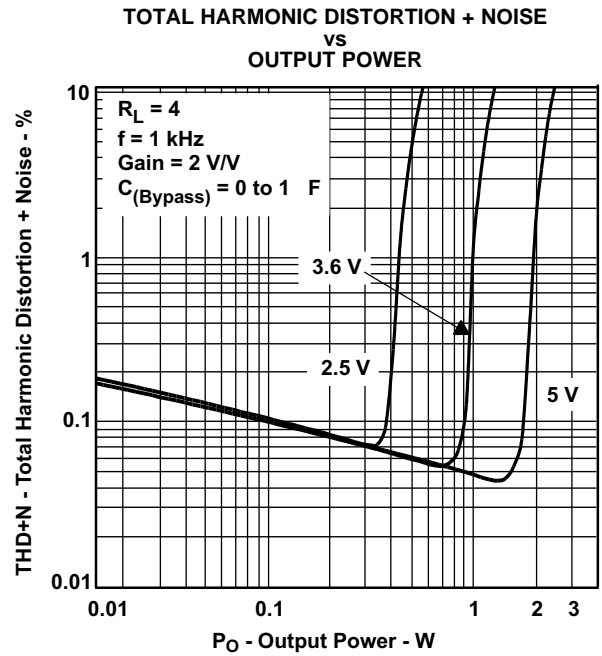

Figure 6.

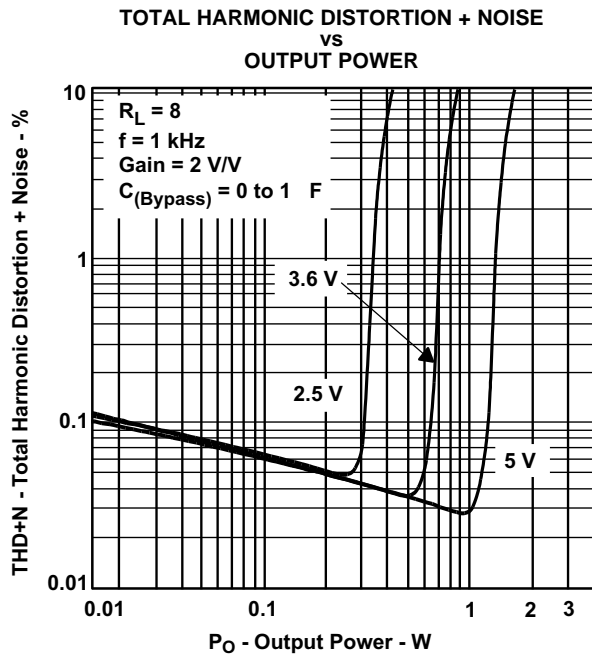

Figure 7.

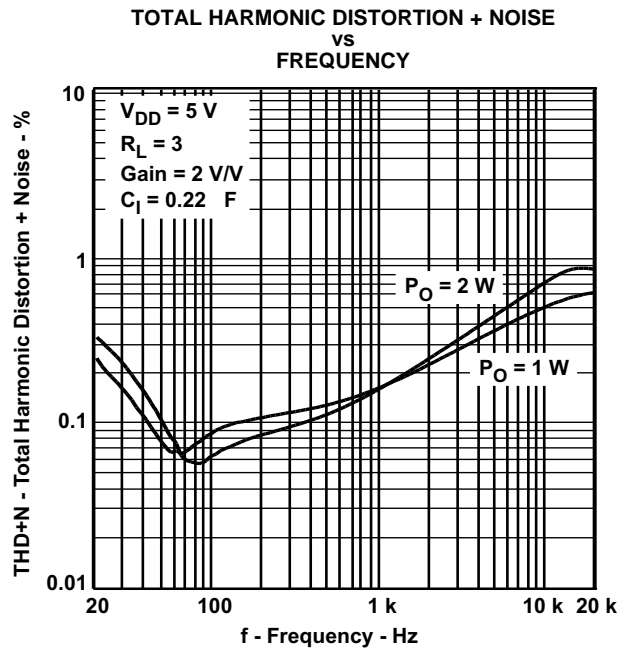

Figure 8.

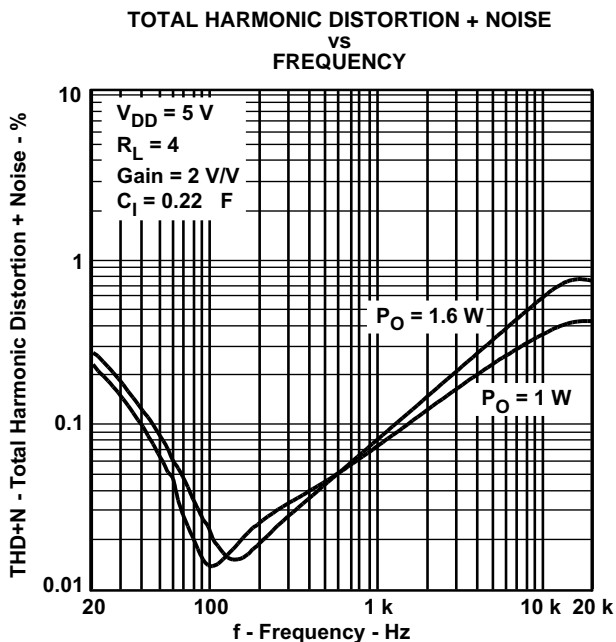

Figure 9.

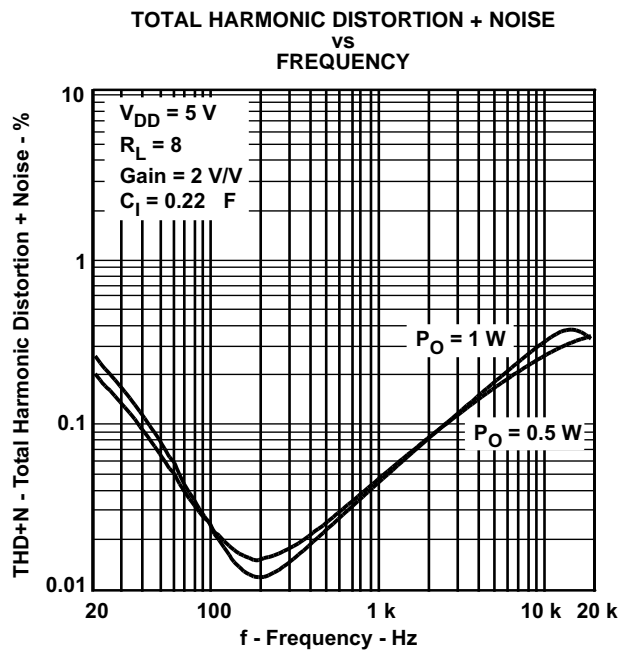

Figure 10.

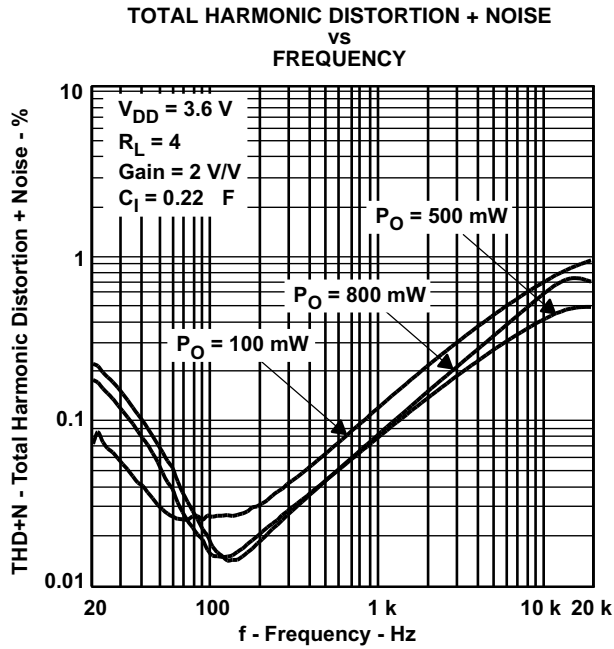

Figure 11.

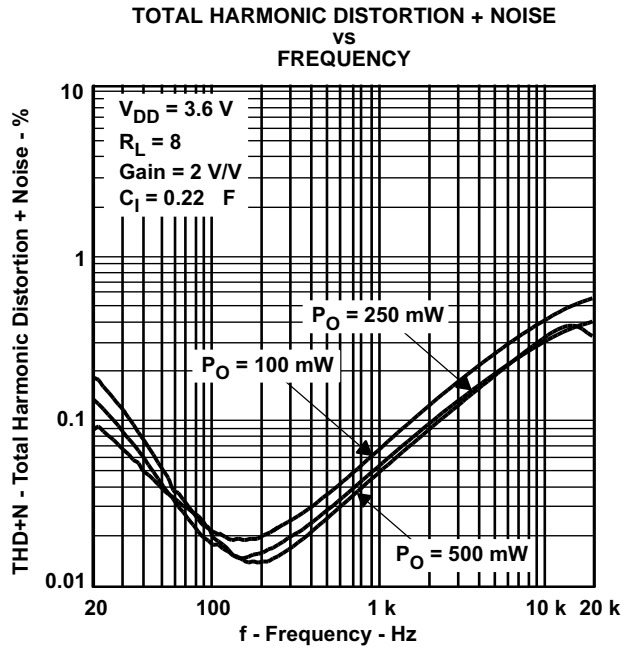

Figure 12.

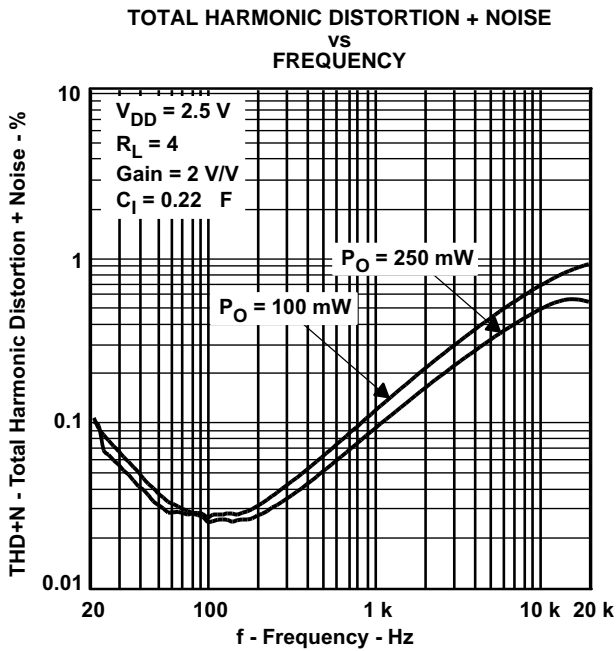

Figure 13.

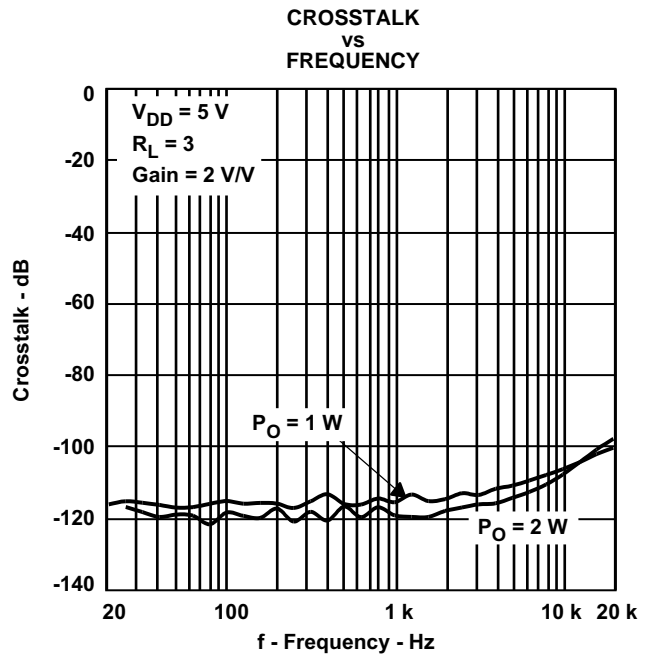

Figure 14.

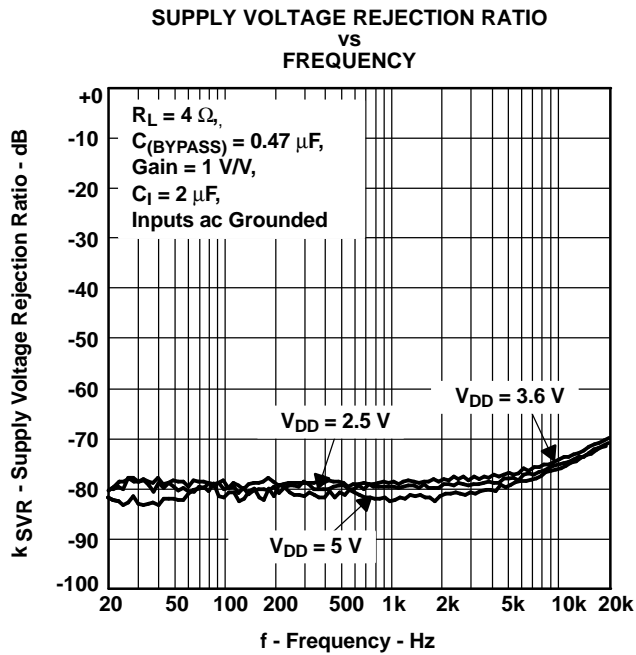

Figure 15.

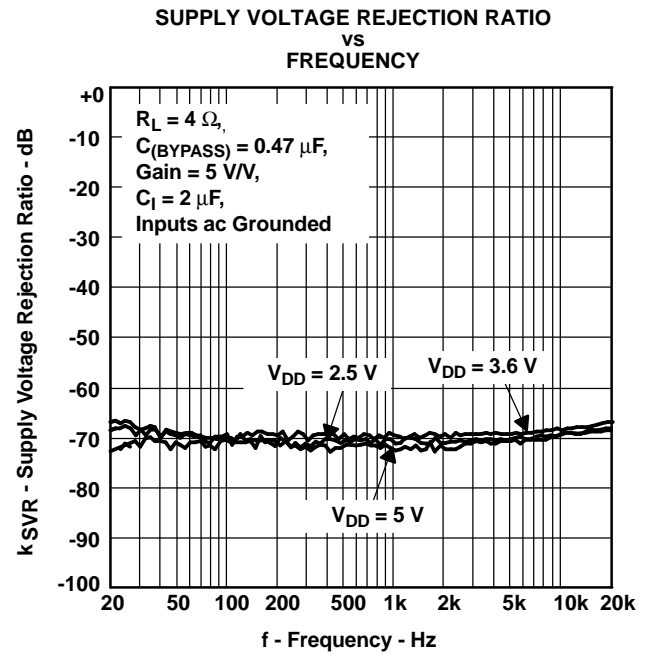

Figure 16.

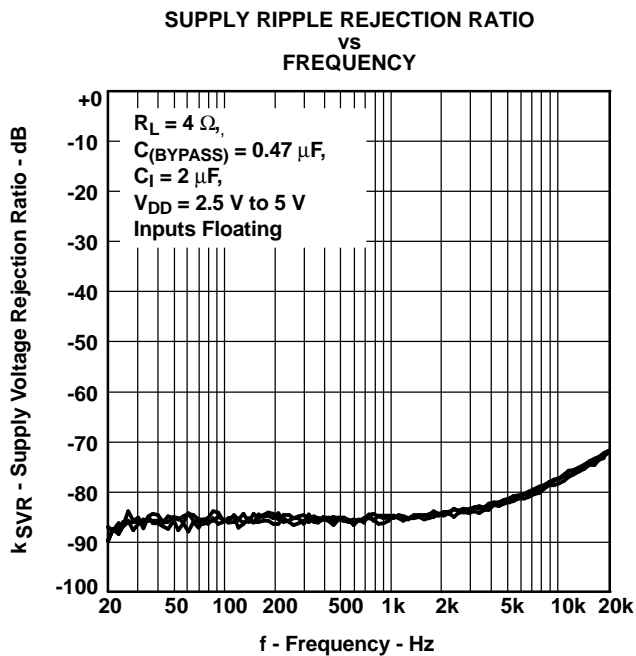

Figure 17.

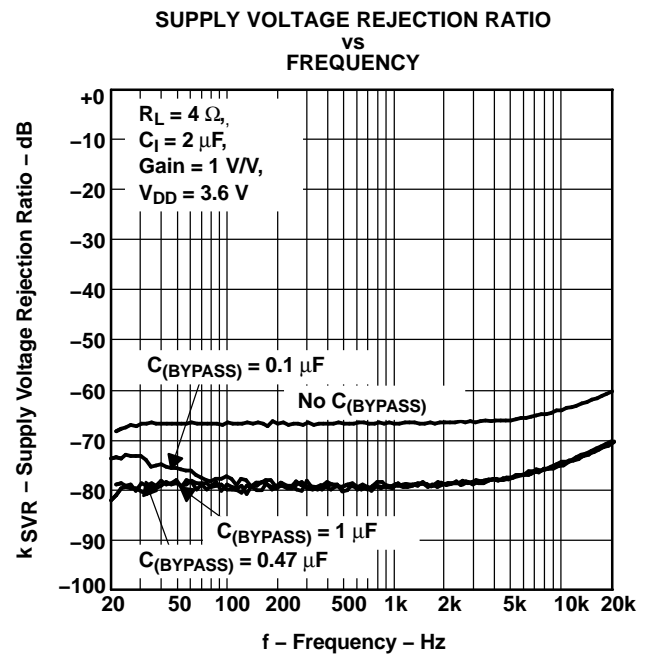

Figure 18.

GSM POWER SUPPLY REJECTION
vs
TIME

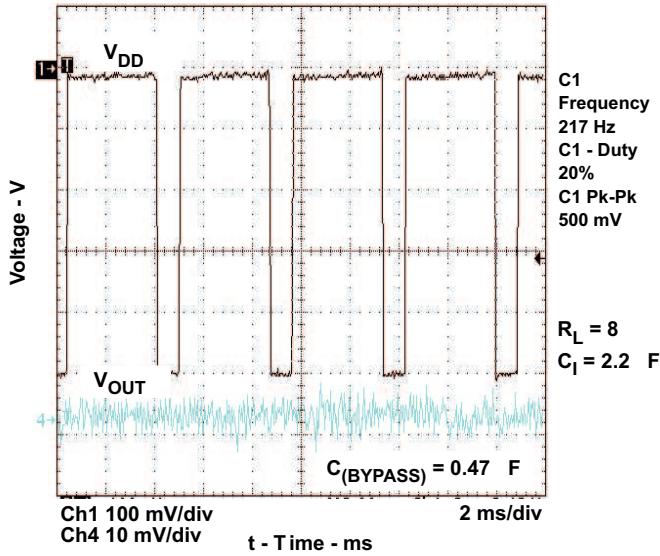

Figure 19.

GSM POWER SUPPLY REJECTION
vs
FREQUENCY

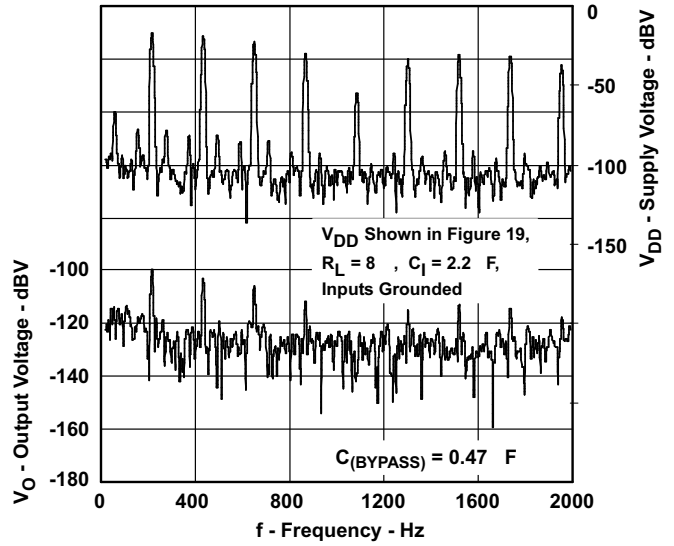

Figure 20.

COMMON MODE REJECTION RATIO
vs
FREQUENCY

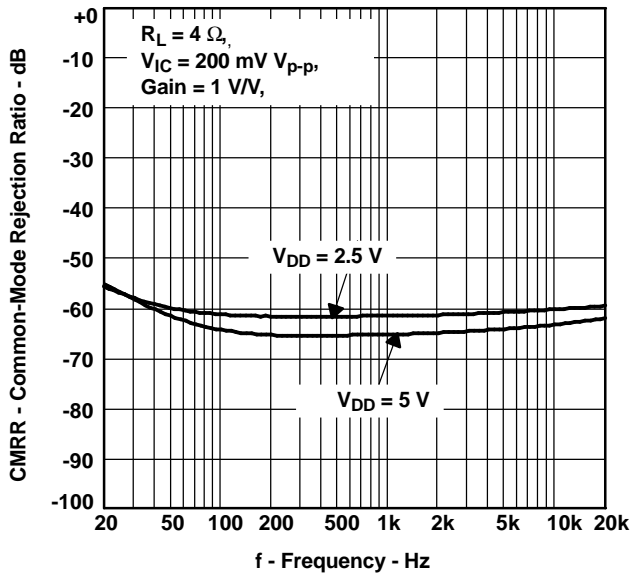

Figure 21.

COMMON-MODE REJECTION RATIO
vs
COMMON-MODE INPUT VOLTAGE

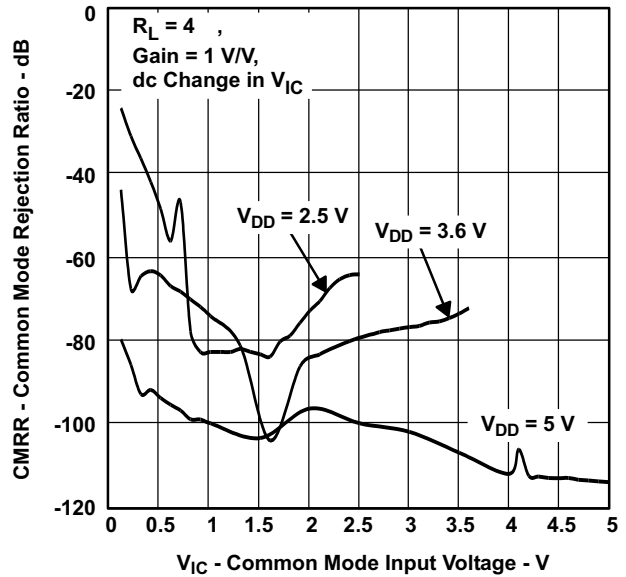

Figure 22.

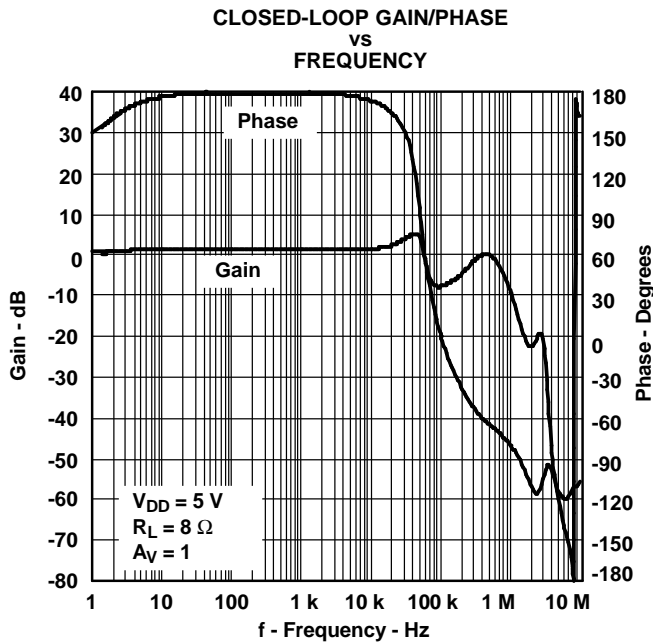

Figure 23.

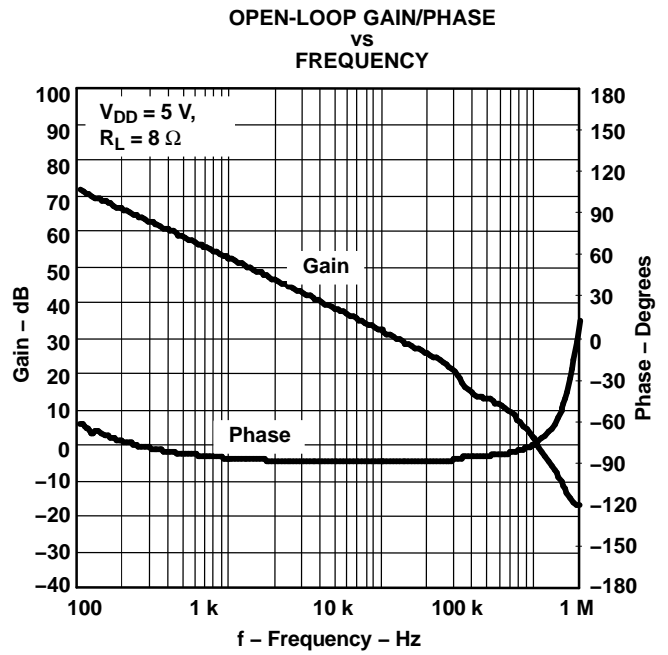

Figure 24.

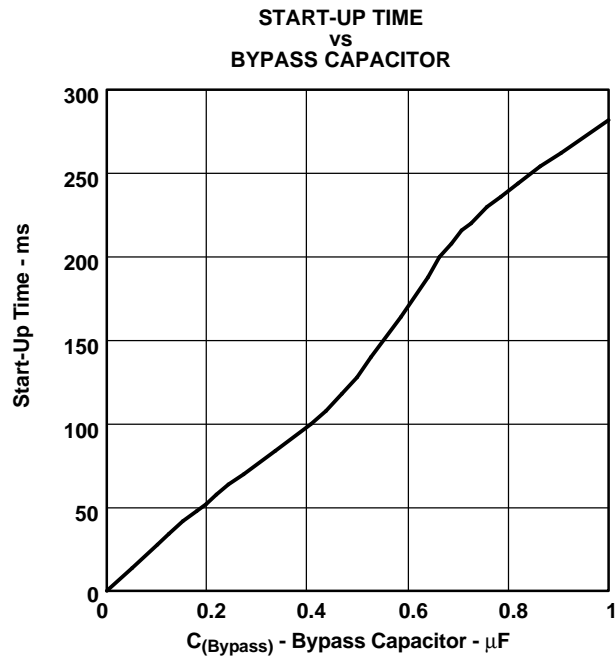

Figure 25.

APPLICATION INFORMATION

STEREO OPERATION

The TPA6020A2 is a stereo amplifier that can be operated in either a mono or stereo configuration. Each channel has independent shutdown control, giving the user greater flexibility.

Bypass Capacitor Configuration

If Bypass capacitors are used, it is necessary to use separate bypass capacitors for each bypass pin. (See the section entitled *Bypass Capacitor (C_{BYPASS}) and Start-Up Time*)

VDD and Decoupling Capacitors

Each VDD pin must have a separate power supply decoupling capacitor (see section entitled *Decoupling Capacitor (C_S)*). A single, bulk decoupling capacitor is also recommended. Additionally, the left and right channel VDD pins must be tied together on the PCB.

FULLY DIFFERENTIAL AMPLIFIER

The TPA6020A2 is a fully differential amplifier with differential inputs and outputs. The fully differential amplifier consists of a differential amplifier and a common-mode amplifier. The differential amplifier ensures that the amplifier outputs a differential voltage that is equal to the differential input times the gain. The common-mode feedback ensures that the common-mode voltage at the output is biased around $V_{DD}/2$ regardless of the common-mode voltage at the input.

Advantages of Fully Differential Amplifiers

- **Input coupling capacitors not required:** A fully differential amplifier with good CMRR, like the TPA6020A2, allows the inputs to be biased at voltage other than mid-supply. For example, if a

DAC has a lower mid-supply voltage than that of the TPA6020A2, the common-mode feedback circuit compensates, and the outputs are still biased at the mid-supply point of the TPA6020A2. The inputs of the TPA6020A2 can be biased from 0.5 V to $V_{DD} - 0.8$ V. If the inputs are biased outside of that range, input-coupling capacitors are required.

- **Mid-supply bypass capacitor, $C_{(BYPASS)}$, not required:** The fully differential amplifier does not require a bypass capacitor. Any shift in the mid-supply voltage affects both positive and negative channels equally, thus canceling at the differential output. Removing the bypass capacitor slightly worsens power supply rejection ratio (k_{SVR}), but a slight decrease of k_{SVR} may be acceptable when an additional component can be eliminated (see [Figure 18](#)).
- **Better RF-immunity:** GSM handsets save power by turning on and shutting off the RF transmitter at a rate of 217 Hz. The transmitted signal is picked up on input and output traces. The fully differential amplifier cancels the signal much better than the typical audio amplifier.

APPLICATION SCHEMATICS

[Figure 26](#) through [Figure 29](#) show application schematics for differential and single-ended inputs. Typical values are shown in [Table 1](#).

Table 1. Typical Component Values

COMPONENT	VALUE
R_I	40 k Ω
$C_{(BYPASS)}^{(1)}$	0.22 μ F
C_S	1 μ F
C_I	0.22 μ F

(1) $C_{(BYPASS)}$ is optional.

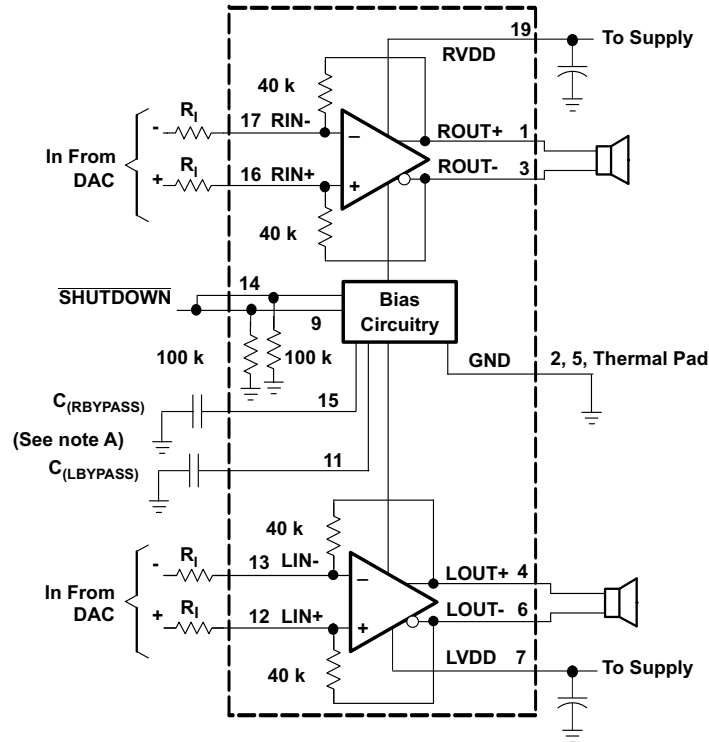

A. $C_{(LBYPASS)}$ and $C_{(RBYPASS)}$ are optional.

Figure 26. Typical Differential Input Application Schematic

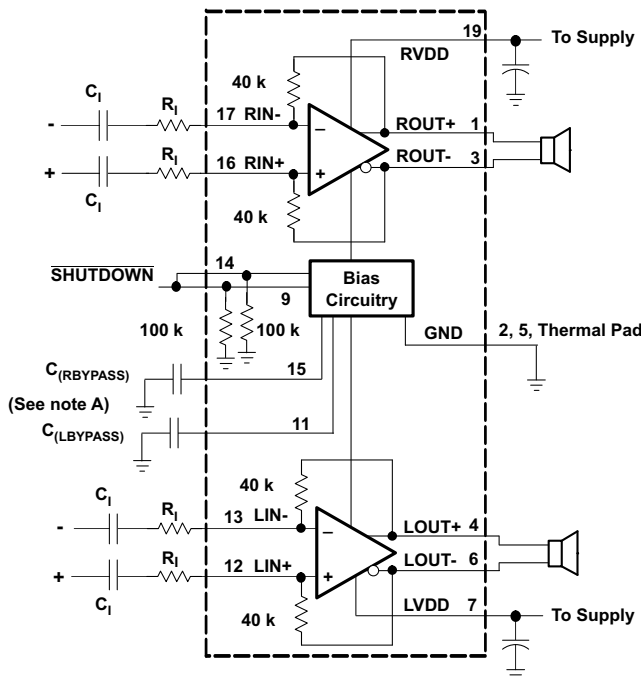

A. $C_{(LBYPASS)}$ and $C_{(RBYPASS)}$ are optional.

Figure 27. Differential Input Application Schematic Optimized With Input Capacitors

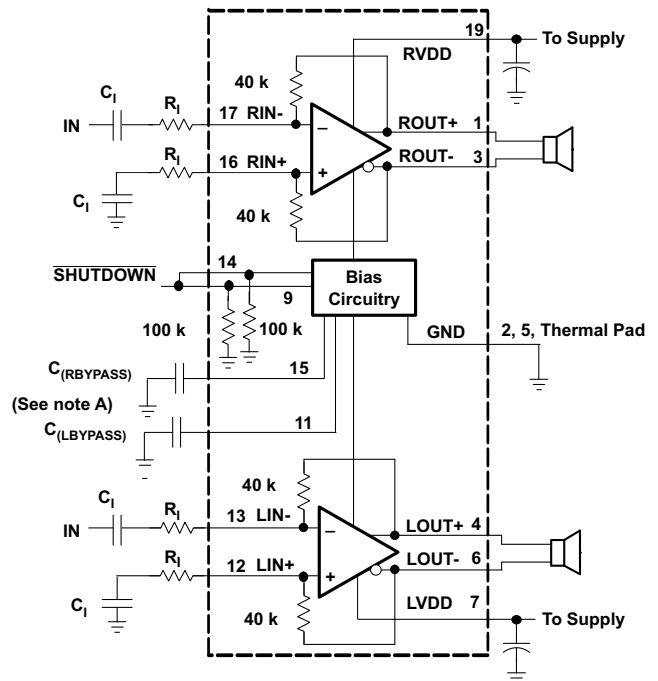

A. $C_{(LBYPASS)}$ and $C_{(RBYPASS)}$ are optional.

Figure 28. Single-Ended Input Application Schematic

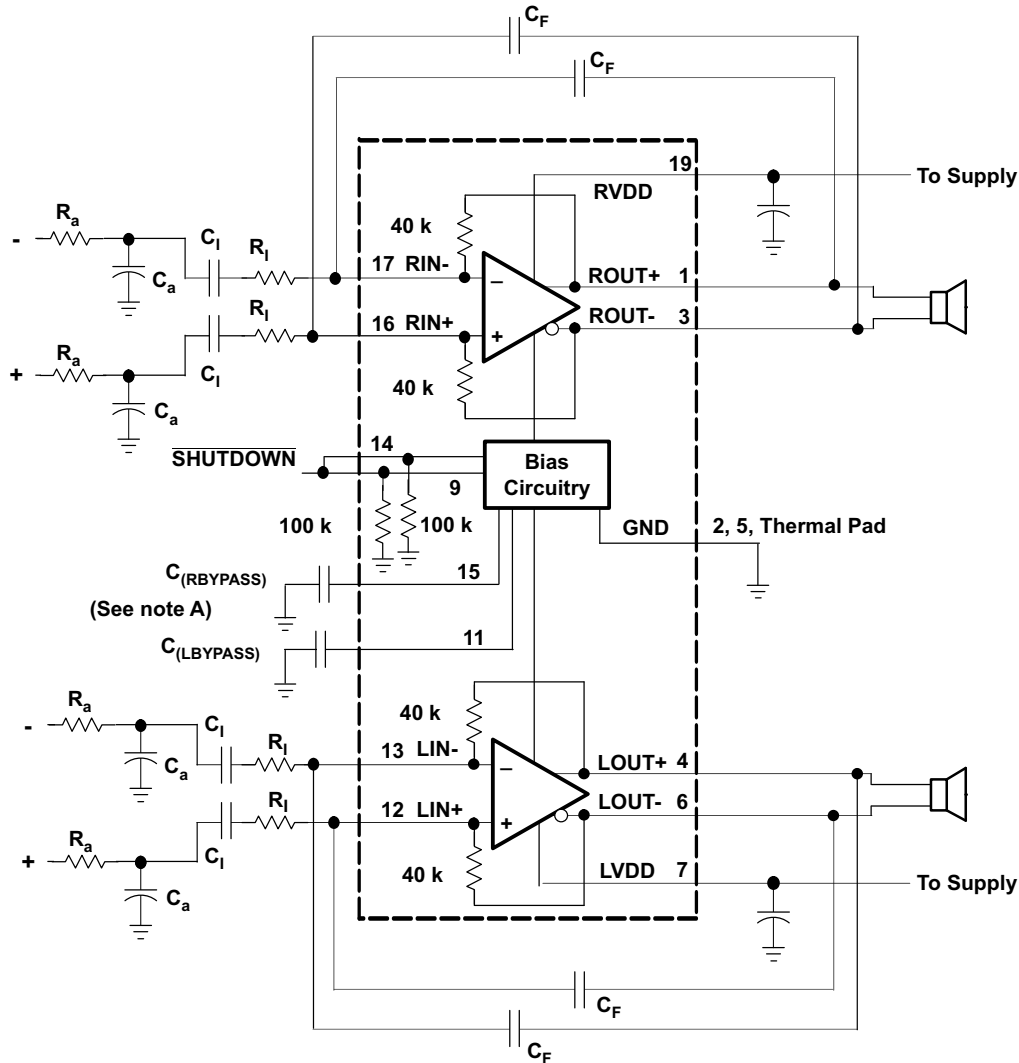

A. $C_{(LBYPASS)}$ and $C_{(RBYPASS)}$ are optional.

Figure 29. Differential Input Application Schematic With Input Bandpass Filter

Selecting Components

Resistors (R_i)

The input resistor (R_i) can be selected to set the gain of the amplifier according to [Equation 1](#).

$$\text{Gain} = R_F/R_i \quad (1)$$

The internal feedback resistors (R_F) are trimmed to 40 kΩ.

Matching input resistors are important to fully differential amplifier applications. Resistor matching has a significant impact on CMRR and PSRR. If the input resistor values are poorly matched, then the CMRR and PSRR performance is diminished. Therefore, 1%-tolerance resistors or better are recommended to optimize performance.

Bypass Capacitor (C_{BYPASS}) and Start-Up Time

The internal voltage divider at the BYPASS pin of this device sets a mid-supply voltage for internal references and sets the output common-mode voltage to $V_{DD}/2$. Adding a capacitor filters any noise into this pin, increasing k_{SVR} . $C_{(BYPASS)}$ also determines the rise time of V_{O+} and V_{O-} when the device exits shutdown. The larger the capacitor, the slower the rise time.

Input Capacitor (C_i)

The TPA6020A2 does not require input coupling capacitors when driven by a differential input source biased from 0.5 V to $V_{DD} - 0.8$ V. Use 1% tolerance or better gain-setting resistors if not using input-coupling capacitors.

In the single-ended input application, an input capacitor, C_I , is required to allow the amplifier to bias the input signal to the proper dc level. In this case, C_I and R_I form a high-pass filter with the corner frequency defined in Equation 2.

$$f_c = \frac{1}{2\pi R_I C_I} \quad (2)$$

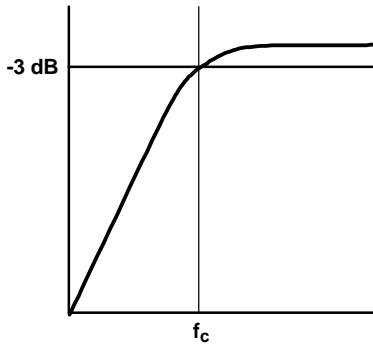

The value of C_I is an important consideration. It directly affects the bass (low frequency) performance of the circuit. Consider the example where R_I is 10 k Ω and the specification calls for a flat bass response down to 100 Hz. Equation 2 is reconfigured as Equation 3.

$$C_I = \frac{1}{2\pi R_I f_c} \quad (3)$$

In this example, C_I is 0.16 μ F, so the likely choice ranges from 0.22 μ F to 0.47 μ F. Ceramic capacitors are preferred because they are the best choice in preventing leakage current. When polarized capacitors are used, the positive side of the capacitor faces the amplifier input in most applications. The input dc level is held at $V_{DD}/2$, typically higher than the source dc level. It is important to confirm the capacitor polarity in the application.

Band-Pass Filter (R_a , C_a , and C_a)

It may be desirable to have signal filtering beyond the one-pole high-pass filter formed by the combination of C_I and R_I . A low-pass filter may be added by placing a capacitor (C_F) between the inputs and outputs, forming a band-pass filter.

An example of when this technique might be used would be in an application where the desirable pass-band range is between 100 Hz and 10 kHz, with a gain of 4 V/V. The following equations illustrate how the proper values of C_F and C_I can be determined.

Step 1: Low-Pass Filter

$$f_{c(\text{LPF})} = \frac{1}{2\pi R_F C_F} \quad (4)$$

where R_F is the internal 40 k Ω resistor

$$f_{c(\text{LPF})} = \frac{1}{2\pi 40 \text{ k}\Omega C_F} \quad (5)$$

Therefore,

$$C_F = \frac{1}{2\pi 40 \text{ k}\Omega f_{c(\text{LPF})}} \quad (6)$$

Substituting 10 kHz for $f_{c(\text{LPF})}$ and solving for C_F :

$$C_F = 398 \text{ pF}$$

Step 2: High-Pass Filter

$$f_{c(\text{HPF})} = \frac{1}{2\pi R_I C_I} \quad (7)$$

where R_I is the input resistor

Because the application in this case requires a gain of 4 V/V, R_I must be set to 10 k Ω .

Substituting R_I into Equation 6.

$$f_{c(\text{HPF})} = \frac{1}{2\pi 10 \text{ k}\Omega C_I} \quad (8)$$

Therefore,

$$C_I = \frac{1}{2\pi 10 \text{ k}\Omega f_{c(\text{HPF})}} \quad (9)$$

Substituting 100 Hz for $f_{c(\text{HPF})}$ and solving for C_I :

$$C_I = 0.16 \mu\text{F}$$

At this point, a first-order band-pass filter has been created with the low-frequency cutoff set to 100 Hz and the high-frequency cutoff set to 10 kHz.

The process can be taken a step further by creating a second-order high-pass filter. This is accomplished by placing a resistor (R_a) and capacitor (C_a) in the input path. It is important to note that R_a must be at least 10 times smaller than R_I ; otherwise its value has a noticeable effect on the gain, as R_a and R_I are in series.

Step 3: Additional Low-Pass Filter

R_a must be at least 10X smaller than R_I ,
Set $R_a = 1 \text{ k}\Omega$

$$f_{c(\text{LPF})} = \frac{1}{2\pi R_a C_a} \quad (10)$$

Therefore,

$$C_a = \frac{1}{2\pi \cdot 1\text{k}\Omega \cdot f_{c(\text{LPF})}} \quad (11)$$

Substituting 10 kHz for $f_{c(\text{LPF})}$ and solving for C_a :

$$C_a = 160 \text{ pF}$$

Figure 30 is a bode plot for the band-pass filter in the previous example. Figure 29 shows how to configure the TPA6020A2 as a band-pass filter.

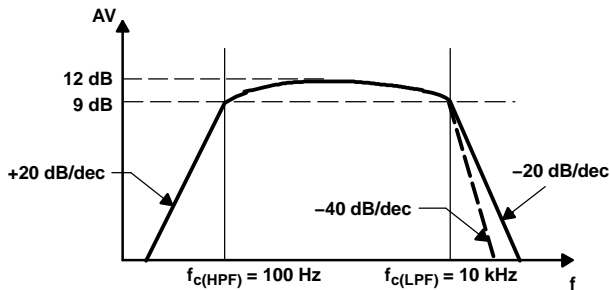

Figure 30. Bode Plot

Decoupling Capacitor (C_S)

The TPA6020A2 is a high-performance CMOS audio amplifier that requires adequate power supply decoupling to ensure the output total harmonic distortion (THD) is as low as possible. Power-supply decoupling also prevents oscillations for long lead lengths between the amplifier and the speaker. For higher frequency transients, spikes, or digital hash on the line, a good low equivalent-series-resistance (ESR) ceramic capacitor, typically 0.1 μF to 1 μF , placed as close as possible to the device V_{DD} lead works best. For filtering lower frequency noise signals, a 10- μF or greater capacitor placed near the audio power amplifier also helps, but is not required in most applications because of the high PSRR of this device.

USING LOW-ESR CAPACITORS

Low-ESR capacitors are recommended throughout this applications section. A real (as opposed to ideal) capacitor can be modeled simply as a resistor in series with an ideal capacitor. The voltage drop across this resistor minimizes the beneficial effects of the capacitor in the circuit. The lower the equivalent value of this resistance the more the real capacitor behaves like an ideal capacitor.

DIFFERENTIAL OUTPUT VERSUS SINGLE-ENDED OUTPUT

Figure 31 shows a Class-AB audio power amplifier (APA) in a fully differential configuration. The TPA6020A2 amplifier has differential outputs driving both ends of the load. One of several potential

benefits to this configuration is power to the load. The differential drive to the speaker means that as one side is slewing up, the other side is slewing down, and vice versa. This in effect doubles the voltage swing on the load as compared to a ground-referenced load. Plugging $2X V_{O(\text{PP})}$ into the power equation, where voltage is squared, yields $4X$ the output power from the same supply rail and load impedance Equation 12.

$$V_{(\text{rms})} = \frac{V_{O(\text{PP})}}{2\sqrt{2}}$$

$$\text{Power} = \frac{V_{(\text{rms})}^2}{R_L} \quad (12)$$

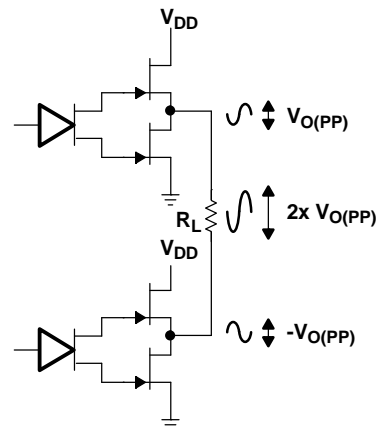

Figure 31. Differential Output Configuration

In a typical wireless handset operating at 3.6 V, bridging raises the power into an 8- Ω speaker from a singled-ended (SE, ground reference) limit of 200 mW to 800 mW. This is a 6-dB improvement in sound power—loudness that can be heard. In addition to increased power, there are frequency-response concerns. Consider the single-supply SE configuration shown in Figure 32. A coupling capacitor (C_C) is required to block the dc-offset voltage from the load. This capacitor can be quite large (approximately 33 μF to 1000 μF) so it tends to be expensive, heavy, occupy valuable PCB area, and have the additional drawback of limiting low-frequency performance. This frequency-limiting effect is due to the high-pass filter network created with the speaker impedance and the coupling capacitance. This is calculated with Equation 13.

$$f_c = \frac{1}{2\pi R_L C_C} \tag{13}$$

For example, a 68- μ F capacitor with an 8- Ω speaker would attenuate low frequencies below 293 Hz. The BTL configuration cancels the dc offsets, which eliminates the need for the blocking capacitors. Low-frequency performance is then limited only by the input network and speaker response. Cost and PCB space are also minimized by eliminating the bulky coupling capacitor.

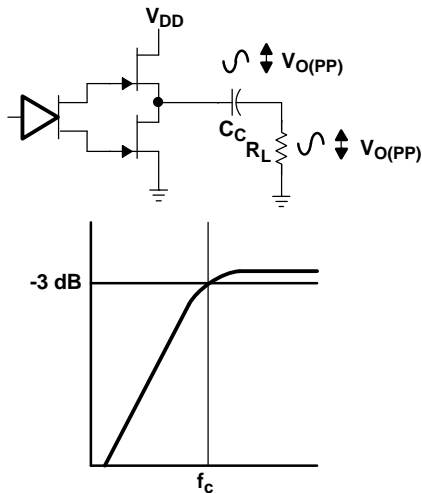

Figure 32. Single-Ended Output and Frequency Response

Increasing power to the load does carry a penalty of increased internal power dissipation. The increased dissipation is understandable considering that the BTL configuration produces 4X the output power of the SE configuration.

FULLY DIFFERENTIAL AMPLIFIER EFFICIENCY AND THERMAL INFORMATION

Class-AB amplifiers are inefficient, primarily because of voltage drop across the output-stage transistors. The two components of this internal voltage drop are the headroom or dc voltage drop that varies inversely to output power, and the sine wave nature of the

output. The total voltage drop can be calculated by subtracting the RMS value of the output voltage from V_{DD} . The internal voltage drop multiplied by the average value of the supply current, $I_{DD(avg)}$, determines the internal power dissipation of the amplifier.

An easy-to-use equation to calculate efficiency starts out as being equal to the ratio of power from the power supply to the power delivered to the load. To accurately calculate the RMS and average values of power in the load and in the amplifier, the current and voltage waveform shapes must first be understood (see Figure 33).

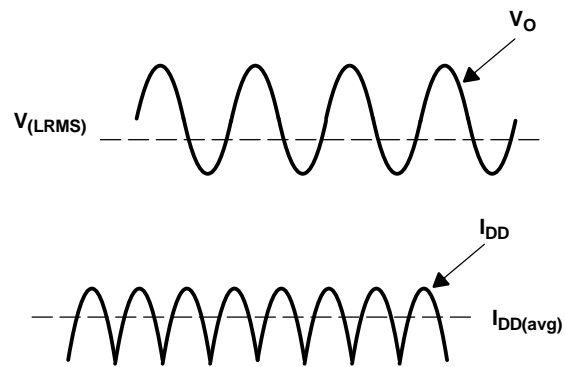

Figure 33. Voltage and Current Waveforms for BTL Amplifiers

Although the voltages and currents for SE and BTL are sinusoidal in the load, currents from the supply are different between SE and BTL configurations. In an SE application the current waveform is a half-wave rectified shape, whereas in BTL it is a full-wave rectified waveform. This means RMS conversion factors are different. Keep in mind that for most of the waveform both the push and pull transistors are not on at the same time, which supports the fact that each amplifier in the BTL device only draws current from the supply for half the waveform. The following equations are the basis for calculating amplifier efficiency.

$$\text{Efficiency of a BTL amplifier} = \frac{P_L}{P_{SUP}}$$

Where:

$$P_L = \frac{V_{L\text{rms}}^2}{R_L}, \text{ and } V_{LRMS} = \frac{V_P}{\sqrt{2}}, \text{ therefore, } P_L = \frac{V_P^2}{2R_L}$$

$$\text{and } P_{SUP} = V_{DD} I_{DD\text{avg}} \text{ and } I_{DD\text{avg}} = \frac{1}{\pi} \int_0^\pi \frac{V_P}{R_L} \sin(t) dt = -\frac{1}{\pi} \times \frac{V_P}{R_L} [\cos(t)]_0^\pi = \frac{2V_P}{\pi R_L}$$

Therefore,

$$P_{SUP} = \frac{2V_{DD} V_P}{\pi R_L}$$

substituting P_L and P_{SUP} into equation 6,

$$\text{Efficiency of a BTL amplifier} = \frac{\frac{V_P^2}{2R_L}}{\frac{2V_{DD} V_P}{\pi R_L}} = \frac{\pi V_P}{4V_{DD}}$$

Where:

$$V_P = \sqrt{2 P_L R_L}$$

P_L = Power delivered to load
 P_{SUP} = Power drawn from power supply
 V_{LRMS} = RMS voltage on BTL load
 R_L = Load resistance
 V_P = Peak voltage on BTL load
 $I_{DD\text{avg}}$ = Average current drawn from the power supply
 V_{DD} = Power supply voltage
 η_{BTL} = Efficiency of a BTL amplifier

(14)

Therefore,

$$\eta_{BTL} = \frac{\pi \sqrt{2 P_L R_L}}{4 V_{DD}}$$

(15)

Table 2. Efficiency and Maximum Ambient Temperature vs Output Power

Output Power (W)	Efficiency (%)	Internal Dissipation (W)	Power From Supply (W)	Max Ambient Temperature (°C)
5-V, Stereo, 3-Ω Systems				
0.5	27.2	2.68	3.68	38
1	38.4	3.20	5.20	17
2	54.4	3.35	7.35	10
2.8	64.4	3.10	8.70	21
5-V, Stereo, 4-Ω BTL Systems				
0.5	31.4	2.18	3.18	59
1	44.4	2.50	4.50	46
2	62.8	2.37	6.37	51
2.5	70.2	2.12	7.12	62
5-V, Stereo, 8-Ω Systems				
0.25	31.4	1.09	1.59	85 ⁽¹⁾
0.5	44.4	1.25	2.25	85 ⁽¹⁾
1	62.8	1.18	3.18	85 ⁽¹⁾
1.36	73.3	0.99	3.71	85 ⁽¹⁾

(1) Package limited to 85°C ambient

Table 2 employs Equation 15 to calculate efficiencies for four different output power levels. Note that the efficiency of the amplifier is quite low for lower power levels and rises sharply as power to the load is increased resulting in a nearly flat internal power dissipation over the normal operating range. Note that the internal dissipation at full output power is less than in the half power range. Calculating the efficiency for a specific system is the key to proper power supply design. For a 2.8-W audio system with 3-Ω loads and a 5-V supply, the maximum draw on the power supply is almost 8.8 W.

A final point to remember about Class-AB amplifiers is how to manipulate the terms in the efficiency equation to the utmost advantage when possible. Note that in Equation 15, V_{DD} is in the denominator. This indicates that as V_{DD} goes down, efficiency goes up.

A simple formula for calculating the maximum power dissipated, P_{Dmax} , may be used for a stereo, differential output application:

$$P_{Dmax} = \frac{4 V_{DD}^2}{R_L} \quad (16)$$

P_{Dmax} for a 5-V, 4-Ω system is 2.53 W.

The maximum ambient temperature depends on the heat sinking ability of the PCB system. The derating factor for the 5 mm x 5 mm QFN package is shown in the dissipation rating table. Converting this to θ_{JA} :

$$\theta_{JA} = \frac{1}{\text{Derating Factor}} = \frac{1}{0.2398} = 41.7^\circ\text{C/W} \quad (17)$$

Given θ_{JA} , the maximum allowable junction temperature, and the maximum internal dissipation, the maximum ambient temperature can be calculated with Equation 18. The maximum recommended junction temperature for the TPA6020A2 is 150°C.

$$\begin{aligned} T_A \text{ Max} &= T_J \text{ Max} - \theta_{JA} P_D \text{ Max} \\ &= 150 - 41.7(2.53) = 44.5^\circ\text{C/W} \end{aligned} \quad (18)$$

Equation 18 shows that the maximum ambient temperature is 44.5°C at maximum power dissipation with a 5-V supply.

Table 2 shows that for most applications no airflow is required to keep junction temperatures in the specified range. The TPA6020A2 is designed with thermal protection that turns the device off when the junction temperature surpasses 150°C to prevent damage to the IC. In addition, using speakers with an impedance higher than 4 Ω dramatically increases the thermal performance by reducing the output current.

The TPA6020A2 is capable of driving impedances as low as 3 Ω, but special layout techniques must be considered in order to achieve optimal performance. In a 5-V, 3-Ω stereo system, the maximum ambient temperature is just 9.1°C. To increase the maximum ambient temperature, θ_{JA} has to be reduced. This is achieved by increasing the amount of copper on the board. Using 3 oz. or 4 oz. copper, and/or additional layers, increases the thermal performance of the device.

PACKAGING INFORMATION

Orderable Device	Status (1)	Package Type	Package Drawing	Pins	Package Qty	Eco Plan (2)	Lead/Ball Finish (6)	MSL Peak Temp (3)	Op Temp (°C)	Device Marking (4/5)	Samples
TPA6020A2RGWR	ACTIVE	VQFN	RGW	20	3000	Green (RoHS & no Sb/Br)	CU NIPDAU	Level-2-260C-1 YEAR	-40 to 85	TPA 6020A2	Samples
TPA6020A2RGWT	ACTIVE	VQFN	RGW	20	250	Green (RoHS & no Sb/Br)	CU NIPDAU	Level-2-260C-1 YEAR	-40 to 85	TPA 6020A2	Samples

(1) The marketing status values are defined as follows:

ACTIVE: Product device recommended for new designs.

LIFEBUY: TI has announced that the device will be discontinued, and a lifetime-buy period is in effect.

NRND: Not recommended for new designs. Device is in production to support existing customers, but TI does not recommend using this part in a new design.

PREVIEW: Device has been announced but is not in production. Samples may or may not be available.

OBSOLETE: TI has discontinued the production of the device.

(2) **RoHS:** TI defines "RoHS" to mean semiconductor products that are compliant with the current EU RoHS requirements for all 10 RoHS substances, including the requirement that RoHS substance do not exceed 0.1% by weight in homogeneous materials. Where designed to be soldered at high temperatures, "RoHS" products are suitable for use in specified lead-free processes. TI may reference these types of products as "Pb-Free".

RoHS Exempt: TI defines "RoHS Exempt" to mean products that contain lead but are compliant with EU RoHS pursuant to a specific EU RoHS exemption.

Green: TI defines "Green" to mean the content of Chlorine (Cl) and Bromine (Br) based flame retardants meet JS709B low halogen requirements of <=1000ppm threshold. Antimony trioxide based flame retardants must also meet the <=1000ppm threshold requirement.

(3) MSL, Peak Temp. - The Moisture Sensitivity Level rating according to the JEDEC industry standard classifications, and peak solder temperature.

(4) There may be additional marking, which relates to the logo, the lot trace code information, or the environmental category on the device.

(5) Multiple Device Markings will be inside parentheses. Only one Device Marking contained in parentheses and separated by a "~" will appear on a device. If a line is indented then it is a continuation of the previous line and the two combined represent the entire Device Marking for that device.

(6) Lead/Ball Finish - Orderable Devices may have multiple material finish options. Finish options are separated by a vertical ruled line. Lead/Ball Finish values may wrap to two lines if the finish value exceeds the maximum column width.

Important Information and Disclaimer:The information provided on this page represents TI's knowledge and belief as of the date that it is provided. TI bases its knowledge and belief on information provided by third parties, and makes no representation or warranty as to the accuracy of such information. Efforts are underway to better integrate information from third parties. TI has taken and continues to take reasonable steps to provide representative and accurate information but may not have conducted destructive testing or chemical analysis on incoming materials and chemicals. TI and TI suppliers consider certain information to be proprietary, and thus CAS numbers and other limited information may not be available for release.

In no event shall TI's liability arising out of such information exceed the total purchase price of the TI part(s) at issue in this document sold by TI to Customer on an annual basis.

TAPE AND REEL INFORMATION

QUADRANT ASSIGNMENTS FOR PIN 1 ORIENTATION IN TAPE

*All dimensions are nominal

Device	Package Type	Package Drawing	Pins	SPQ	Reel Diameter (mm)	Reel Width W1 (mm)	A0 (mm)	B0 (mm)	K0 (mm)	P1 (mm)	W (mm)	Pin1 Quadrant
TPA6020A2RGWR	VQFN	RGW	20	3000	330.0	12.4	5.25	5.25	1.1	8.0	12.0	Q2
TPA6020A2RGWR	VQFN	RGW	20	3000	330.0	12.4	5.3	5.3	1.5	8.0	12.0	Q2
TPA6020A2RGWT	VQFN	RGW	20	250	330.0	12.4	5.25	5.25	1.1	8.0	12.0	Q2
TPA6020A2RGWT	VQFN	RGW	20	250	180.0	12.4	5.3	5.3	1.5	8.0	12.0	Q2

TAPE AND REEL BOX DIMENSIONS



*All dimensions are nominal

Device	Package Type	Package Drawing	Pins	SPQ	Length (mm)	Width (mm)	Height (mm)
TPA6020A2RGWR	VQFN	RGW	20	3000	338.0	355.0	50.0
TPA6020A2RGWR	VQFN	RGW	20	3000	367.0	367.0	35.0
TPA6020A2RGWT	VQFN	RGW	20	250	338.0	355.0	50.0
TPA6020A2RGWT	VQFN	RGW	20	250	210.0	185.0	35.0

MECHANICAL DATA

RGW (S-PVQFN-N20)

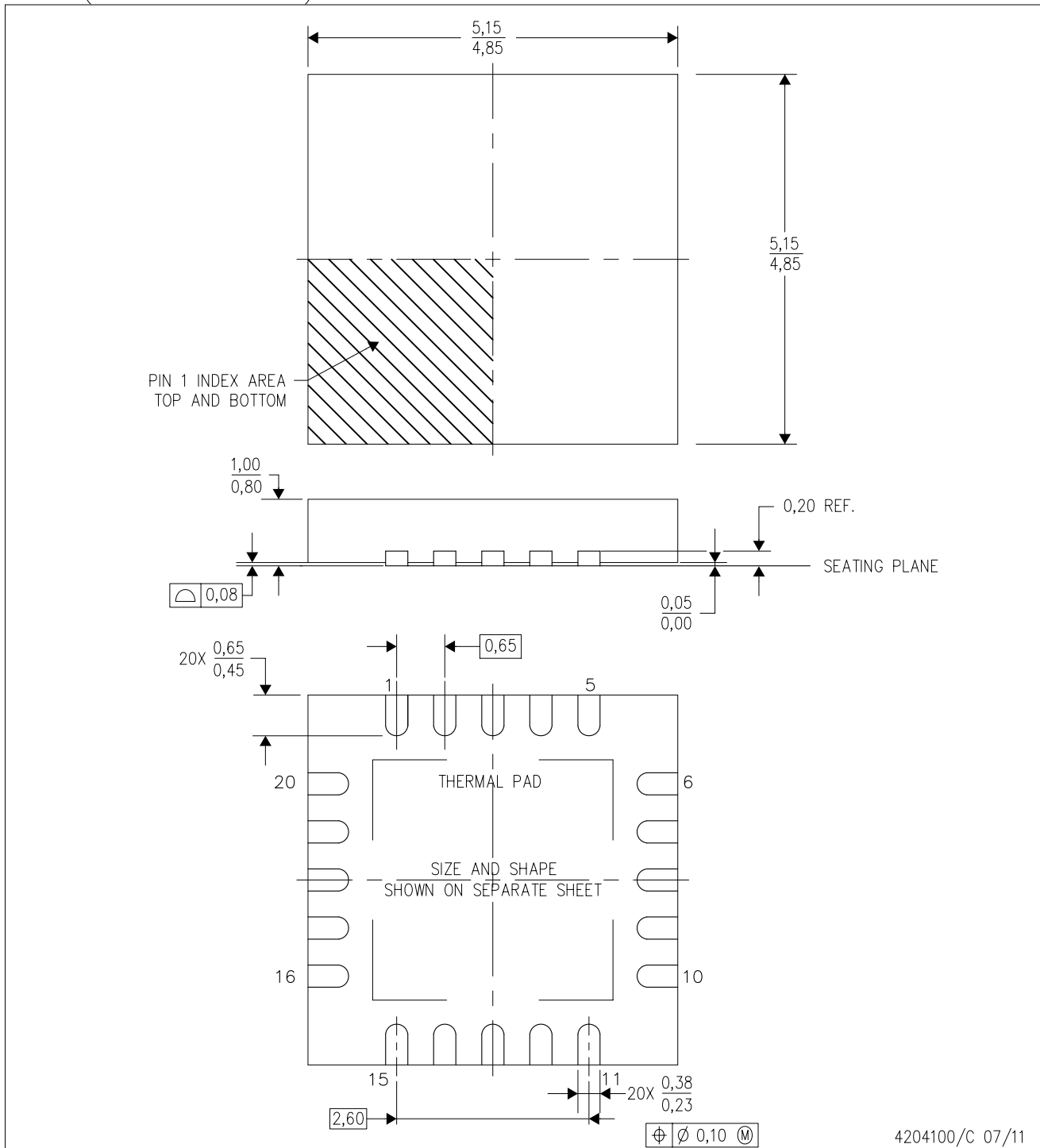
PLASTIC QUAD FLATPACK NO-LEAD



- NOTES:
- All linear dimensions are in millimeters. Dimensioning and tolerancing per ASME Y14.5-1994.
 - This drawing is subject to change without notice.
 - Quad Flat pack, No-leads (QFN) package configuration
 - The package thermal pad must be soldered to the board for thermal and mechanical performance.
 - See the additional figure in the Product Data Sheet for details regarding the exposed thermal pad features and dimensions.
 - Falls within JEDEC MO-220.

RGW (S-PVQFN-N20)

PLASTIC QUAD FLATPACK NO-LEAD

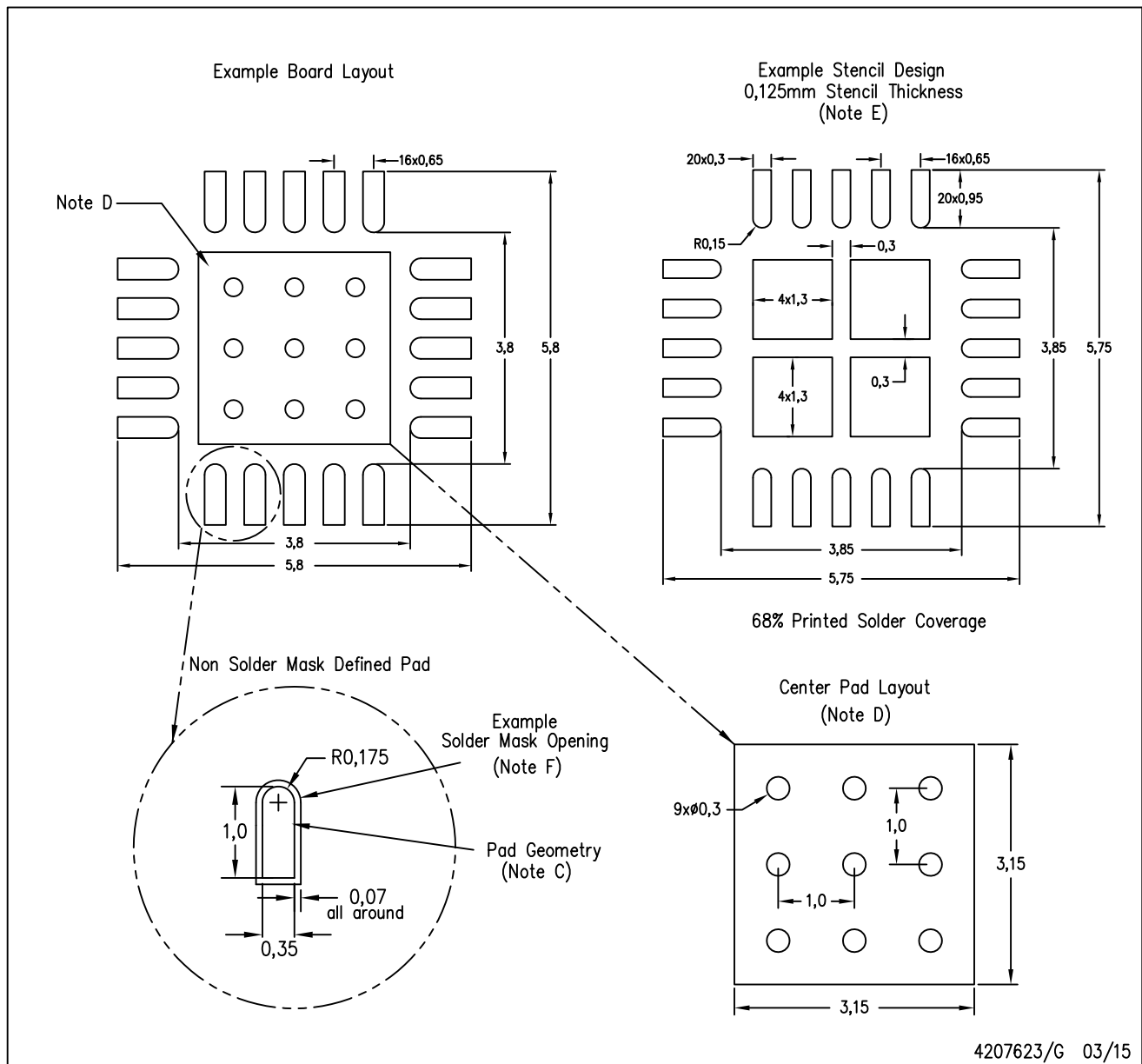

- NOTES:
- A. All linear dimensions are in millimeters.
 - B. This drawing is subject to change without notice.
 - C. Publication IPC-7351 is recommended for alternate designs.
 - D. This package is designed to be soldered to a thermal pad on the board. Refer to Application Note, QFN Packages, Texas Instruments Literature No. SLUA271, and also the Product Data Sheets for specific thermal information, via requirements, and recommended board layout. These documents are available at www.ti.com <<http://www.ti.com>>.
 - E. Laser cutting apertures with trapezoidal walls and also rounding corners will offer better paste release. Customers should contact their board assembly site for stencil design recommendations. Refer to IPC 7525 for stencil design considerations.
 - F. Customers should contact their board fabrication site for solder mask tolerances.

IMPORTANT NOTICE

Texas Instruments Incorporated (TI) reserves the right to make corrections, enhancements, improvements and other changes to its semiconductor products and services per JESD46, latest issue, and to discontinue any product or service per JESD48, latest issue. Buyers should obtain the latest relevant information before placing orders and should verify that such information is current and complete.

TI's published terms of sale for semiconductor products (<http://www.ti.com/sc/docs/stdterms.htm>) apply to the sale of packaged integrated circuit products that TI has qualified and released to market. Additional terms may apply to the use or sale of other types of TI products and services.

Reproduction of significant portions of TI information in TI data sheets is permissible only if reproduction is without alteration and is accompanied by all associated warranties, conditions, limitations, and notices. TI is not responsible or liable for such reproduced documentation. Information of third parties may be subject to additional restrictions. Resale of TI products or services with statements different from or beyond the parameters stated by TI for that product or service voids all express and any implied warranties for the associated TI product or service and is an unfair and deceptive business practice. TI is not responsible or liable for any such statements.

Buyers and others who are developing systems that incorporate TI products (collectively, "Designers") understand and agree that Designers remain responsible for using their independent analysis, evaluation and judgment in designing their applications and that Designers have full and exclusive responsibility to assure the safety of Designers' applications and compliance of their applications (and of all TI products used in or for Designers' applications) with all applicable regulations, laws and other applicable requirements. Designer represents that, with respect to their applications, Designer has all the necessary expertise to create and implement safeguards that (1) anticipate dangerous consequences of failures, (2) monitor failures and their consequences, and (3) lessen the likelihood of failures that might cause harm and take appropriate actions. Designer agrees that prior to using or distributing any applications that include TI products, Designer will thoroughly test such applications and the functionality of such TI products as used in such applications.

TI's provision of technical, application or other design advice, quality characterization, reliability data or other services or information, including, but not limited to, reference designs and materials relating to evaluation modules, (collectively, "TI Resources") are intended to assist designers who are developing applications that incorporate TI products; by downloading, accessing or using TI Resources in any way, Designer (individually or, if Designer is acting on behalf of a company, Designer's company) agrees to use any particular TI Resource solely for this purpose and subject to the terms of this Notice.

TI's provision of TI Resources does not expand or otherwise alter TI's applicable published warranties or warranty disclaimers for TI products, and no additional obligations or liabilities arise from TI providing such TI Resources. TI reserves the right to make corrections, enhancements, improvements and other changes to its TI Resources. TI has not conducted any testing other than that specifically described in the published documentation for a particular TI Resource.

Designer is authorized to use, copy and modify any individual TI Resource only in connection with the development of applications that include the TI product(s) identified in such TI Resource. NO OTHER LICENSE, EXPRESS OR IMPLIED, BY ESTOPPEL OR OTHERWISE TO ANY OTHER TI INTELLECTUAL PROPERTY RIGHT, AND NO LICENSE TO ANY TECHNOLOGY OR INTELLECTUAL PROPERTY RIGHT OF TI OR ANY THIRD PARTY IS GRANTED HEREIN, including but not limited to any patent right, copyright, mask work right, or other intellectual property right relating to any combination, machine, or process in which TI products or services are used. Information regarding or referencing third-party products or services does not constitute a license to use such products or services, or a warranty or endorsement thereof. Use of TI Resources may require a license from a third party under the patents or other intellectual property of the third party, or a license from TI under the patents or other intellectual property of TI.

TI RESOURCES ARE PROVIDED "AS IS" AND WITH ALL FAULTS. TI DISCLAIMS ALL OTHER WARRANTIES OR REPRESENTATIONS, EXPRESS OR IMPLIED, REGARDING RESOURCES OR USE THEREOF, INCLUDING BUT NOT LIMITED TO ACCURACY OR COMPLETENESS, TITLE, ANY EPIDEMIC FAILURE WARRANTY AND ANY IMPLIED WARRANTIES OF MERCHANTABILITY, FITNESS FOR A PARTICULAR PURPOSE, AND NON-INFRINGEMENT OF ANY THIRD PARTY INTELLECTUAL PROPERTY RIGHTS. TI SHALL NOT BE LIABLE FOR AND SHALL NOT DEFEND OR INDEMNIFY DESIGNER AGAINST ANY CLAIM, INCLUDING BUT NOT LIMITED TO ANY INFRINGEMENT CLAIM THAT RELATES TO OR IS BASED ON ANY COMBINATION OF PRODUCTS EVEN IF DESCRIBED IN TI RESOURCES OR OTHERWISE. IN NO EVENT SHALL TI BE LIABLE FOR ANY ACTUAL, DIRECT, SPECIAL, COLLATERAL, INDIRECT, PUNITIVE, INCIDENTAL, CONSEQUENTIAL OR EXEMPLARY DAMAGES IN CONNECTION WITH OR ARISING OUT OF TI RESOURCES OR USE THEREOF, AND REGARDLESS OF WHETHER TI HAS BEEN ADVISED OF THE POSSIBILITY OF SUCH DAMAGES.

Unless TI has explicitly designated an individual product as meeting the requirements of a particular industry standard (e.g., ISO/TS 16949 and ISO 26262), TI is not responsible for any failure to meet such industry standard requirements.

Where TI specifically promotes products as facilitating functional safety or as compliant with industry functional safety standards, such products are intended to help enable customers to design and create their own applications that meet applicable functional safety standards and requirements. Using products in an application does not by itself establish any safety features in the application. Designers must ensure compliance with safety-related requirements and standards applicable to their applications. Designer may not use any TI products in life-critical medical equipment unless authorized officers of the parties have executed a special contract specifically governing such use. Life-critical medical equipment is medical equipment where failure of such equipment would cause serious bodily injury or death (e.g., life support, pacemakers, defibrillators, heart pumps, neurostimulators, and implantables). Such equipment includes, without limitation, all medical devices identified by the U.S. Food and Drug Administration as Class III devices and equivalent classifications outside the U.S.

TI may expressly designate certain products as completing a particular qualification (e.g., Q100, Military Grade, or Enhanced Product). Designers agree that it has the necessary expertise to select the product with the appropriate qualification designation for their applications and that proper product selection is at Designers' own risk. Designers are solely responsible for compliance with all legal and regulatory requirements in connection with such selection.

Designer will fully indemnify TI and its representatives against any damages, costs, losses, and/or liabilities arising out of Designer's non-compliance with the terms and provisions of this Notice.

Looking for pricing, stock, or lifecycle information?

Click below to explore more details on WIN SOURCE:

 [View TPA6020A2RGWT](#) on WIN SOURCE

 [Texas Instruments](#) Information

Optimize Your Supply Chain with WIN SOURCE Solutions

-  Global Sourcing Solution
-  Obsolete Management
-  Cost Control Management
-  Shortage Management
-  Alternative Solution
-  Excess Inventory Management