

TPA0253
1-W MONO AUDIO POWER AMPLIFIER
WITH HEADPHONE DRIVE

SLOS280D – JANUARY 2000 – REVISED NOVEMBER 2002

- Ideal for Notebook Computers, PDAs, and Other Small Portable Audio Devices
- 1 W Into 8-Ω From 5-V Supply
- 0.3 W Into 8-Ω From 3-V Supply
- Stereo Head Phone Drive
- Mono (BTL) Signal Created by Summing Left and Right Signals Internally
- Wide Power Supply Compatibility
2.5 V to 5.5 V
- Low Supply Current
 - 3.2 mA Typical at 5 V
 - 2.7 mA Typical at 3 V
- Shutdown Control . . . 1 μA Typical
- Shutdown Pin Is TTL Compatible
- –40°C to 85°C Operating Temperature Range
- Space-Saving, Thermally-Enhanced MSOP Packaging

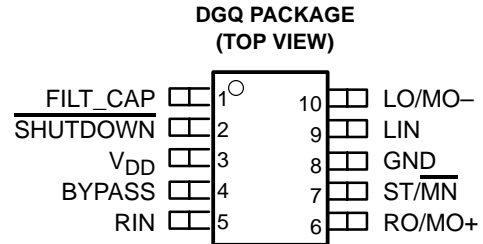

description

The TPA0253 is a 1-W mono bridge-tied-load (BTL) amplifier designed to drive speakers with as low as 8-Ω impedance. The mono signal is created by summing left and right inputs internally. The amplifier can be reconfigured on the fly to drive two stereo single-ended (SE) signals into headphones. This makes the device ideal for use in small notebook computers, PDAs, digital personal audio players, anyplace a mono speaker and stereo headphones are required. From a 5-V supply, the TPA0253 can deliver 1-W of power into an 8-Ω speaker.

The gain of the input stage is set by the user-selected input resistor and a 50-kΩ internal feedback resistor ($A_V = -R_F/R_I$). The power stage is internally configured with a gain of –1.25 V/V in SE mode, and –2.5 V/V in BTL mode. Thus, the overall gain of the amplifier is 62.5 kΩ/R_I in SE mode and 125 kΩ/R_I in BTL mode. The input terminals are high-impedance CMOS inputs, and can be used as summing nodes.

The TPA0253 is available in the 10-pin thermally-enhanced MSOP package (DGQ) and operates over an ambient temperature range of –40°C to 85°C.

AVAILABLE OPTIONS

T _A	PACKAGED DEVICES	MSOP SYMBOLIZATION
	MSOP† (DGQ)	
–40°C to 85°C	TPA0253DGQ	AEL

† The DGQ package are available taped and reeled. To order a taped and reeled part, add the suffix R to the part number (e.g., TPA0253DGQR).



Please be aware that an important notice concerning availability, standard warranty, and use in critical applications of Texas Instruments semiconductor products and disclaimers thereto appears at the end of this data sheet.

PRODUCTION DATA information is current as of publication date. Products conform to specifications per the terms of Texas Instruments standard warranty. Production processing does not necessarily include testing of all parameters.



POST OFFICE BOX 655303 • DALLAS, TEXAS 75265

Copyright © 2002, Texas Instruments Incorporated

TPA0253 1-W MONO AUDIO POWER AMPLIFIER WITH HEADPHONE DRIVE

SLOS280D – JANUARY 2000 – REVISED NOVEMBER 2002

schematic

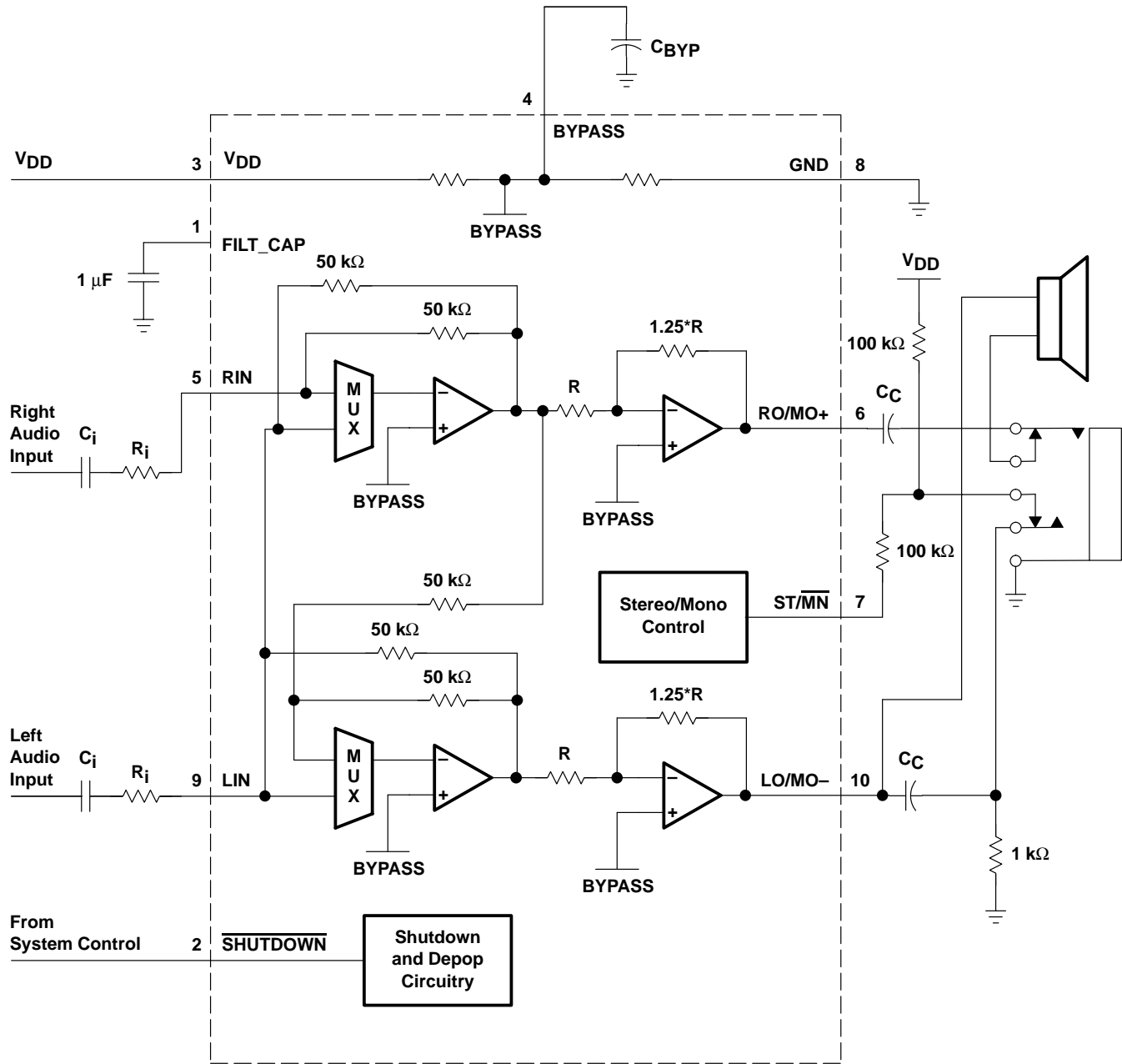

Terminal Functions

TERMINAL NAME	NO.	I/O	DESCRIPTION
BYPASS	4	I	Midrail bias voltage
FILT_CAP	1		Terminal used to filter power supply
GND	8		Ground terminal
LIN	9	I	Left-channel input terminal
LO/MO-	10	O	Left-output in SE mode and mono negative output in BTL mode.
RIN	5	I	Right-channel input terminal
RO/MO+	6	O	Right-output in SE mode and mono positive output in BTL mode
$\overline{\text{SHUTDOWN}}$	2	I	TTL-compatible shutdown terminal
$\overline{\text{ST/MN}}$	7	I	Selects between stereo and mono mode. When held high, the amplifier is in SE stereo mode; while held low, the amplifier is in BTL mono mode.
V _{DD}	3	I	Positive power supply

absolute maximum ratings over operating free-air temperature range (unless otherwise noted)†

Supply voltage, V _{DD}	6 V
Input voltage range, V _I	-0.3 V to V _{DD} +0.3 V
Continuous total power dissipation	internally limited (see Dissipation Rating Table)
Operating free-air temperature range, T _A (see Table 3)	-40°C to 85°C
Operating junction temperature range, T _J	-40°C to 150°C
Storage temperature range, T _{stg}	-65°C to 150°C
Lead temperature 1,6 mm (1/16 inch) from case for 10 seconds	260°C

† Stresses beyond those listed under “absolute maximum ratings” may cause permanent damage to the device. These are stress ratings only, and functional operation of the device at these or any other conditions beyond those indicated under “recommended operating conditions” is not implied. Exposure to absolute-maximum-rated conditions for extended periods may affect device reliability.

DISSIPATION RATING TABLE

PACKAGE	T _A ≤ 25°C	DERATING FACTOR	T _A = 70°C	T _A = 85°C
DGQ	2.14 W [§]	17.1 mW/°C	1.37 W	1.11 W

‡ Please see the Texas Instruments document, *PowerPAD Thermally Enhanced Package Application Report* (SLMA002), for more information on the PowerPAD™ package. The thermal data was measured on a PCB layout based on the information in the section entitled *Texas Instruments Recommended Board for PowerPAD* on page 33 of that document.

TPA0253
1-W MONO AUDIO POWER AMPLIFIER
WITH HEADPHONE DRIVE

SLOS280D – JANUARY 2000 – REVISED NOVEMBER 2002

recommended operating conditions

			MIN	MAX	UNIT
Supply voltage, V_{DD}			2.5	5.5	V
High-level input voltage, V_{IH}	ST/MN	$V_{DD} = 3\text{ V}$	2.7		V
		$V_{DD} = 5\text{ V}$	4.5		
	SHUTDOWN		2		
Low-level input voltage, V_{IL}	ST/MN	$V_{DD} = 3\text{ V}$		1.65	V
		$V_{DD} = 5\text{ V}$		2.75	
	SHUTDOWN			0.8	
Operating free-air temperature, T_A			-40	85	°C

electrical characteristics at specified free-air temperature, $V_{DD} = 3\text{ V}$, $T_A = 25^\circ\text{C}$ (unless otherwise noted)

PARAMETER		TEST CONDITIONS	MIN	TYP	MAX	UNIT
$ V_{OO} $	Output offset voltage (measured differentially)	$R_L = 4\ \Omega$, ST/MN = 0 V, SHUTDOWN = 2 V			30	mV
PSRR	Power supply rejection ratio	$V_{DD} = 2.9\text{ V to } 3.1\text{ V}$, BTL mode		65		dB
$ I_{IH} $	High-level input current	SHUTDOWN, $V_{DD} = 3.3\text{ V}$, $V_I = V_{DD}$			1	μA
		ST/MN, $V_{DD} = 3.3\text{ V}$, $V_I = V_{DD}$			1	
$ I_{IL} $	Low-level input current	SHUTDOWN, $V_{DD} = 3.3\text{ V}$, $V_I = 0\text{ V}$			1	μA
		ST/MN, $V_{DD} = 3.3\text{ V}$, $V_I = 0\text{ V}$			1	
Z_I	Input impedance			50		k Ω
I_{DD}	Supply current	$V_{DD} = 2.5\text{ V}$, SHUTDOWN = 2 V		2.7	4	mA
$I_{DD(SD)}$	Supply current, shutdown mode	SHUTDOWN = 0 V		1	10	μA
R_F	Feedback resistor	$V_{DD} = 2.5\text{ V}$, $R_L = 4\ \Omega$, ST/MN = 1.375 V, SHUTDOWN = 2 V	47	50	57	k Ω

operating characteristics, $V_{DD} = 3\text{ V}$, $T_A = 25^\circ\text{C}$, $R_L = 8\ \Omega$, $f = 1\text{ kHz}$ (unless otherwise noted)

PARAMETER		TEST CONDITIONS	MIN	TYP	MAX	UNIT
P_O	Output power, see Note 1	THD = 0.1%, BTL mode, Gain = 14 dB		300		mW
		THD = 0.1%, SE mode, $R_L = 32\ \Omega$, Gain = 1.9 dB		30		
THD + N	Total harmonic distortion plus noise	$P_O = 250\text{ mW}$, $f = 20\text{ Hz to } 20\text{ kHz}$		0.2%		
BOM	Maximum output power bandwidth	Gain = 1.9 dB, THD = 2%		20		kHz
	Supple ripple rejection ratio	$f = 1\text{ kHz}$, $C_{(BYP)} = 0.47\ \mu\text{F}$	BTL mode	46		dB
			SE mode	68		
V_n	Noise output voltage	$C_{(BYP)} = 0.47\ \mu\text{F}$, $f = 20\text{ Hz to } 20\text{ kHz}$	BTL mode	83		μV_{RMS}
			SE mode	33		

NOTE 1: Output power is measured at the output terminals of the device at $f = 1\text{ kHz}$.



TPA0253
1-W MONO AUDIO POWER AMPLIFIER
WITH HEADPHONE DRIVE

SLOS280D – JANUARY 2000 – REVISED NOVEMBER 2002

electrical characteristics at specified free-air temperature, $V_{DD} = 5\text{ V}$, $T_A = 25^\circ\text{C}$ (unless otherwise noted)

PARAMETER		TEST CONDITIONS	MIN	TYP	MAX	UNIT
$ V_{OO} $	Output offset voltage (measured differentially)	$R_L = 4\ \Omega$, $ST/MN = 0\text{ V}$, $SHUTDOWN = 2\text{ V}$			30	mV
PSRR	Power supply rejection ratio	$V_{DD} = 4.9\text{ V}$ to 5.1 V , BTL mode		62		dB
$ I_{IH} $	High-level input current	$SHUTDOWN$, $V_{DD} = 5.5\text{ V}$, $V_I = V_{DD}$			1	μA
		ST/MN , $V_{DD} = 5.5\text{ V}$, $V_I = V_{DD}$			1	
$ I_{IL} $	Low-level input current	$SHUTDOWN$, $V_{DD} = 5.5\text{ V}$, $V_I = 0\text{ V}$			1	μA
		ST/MN , $V_{DD} = 5.5\text{ V}$, $V_I = 0\text{ V}$			1	
Z_I	Input impedance			50		k Ω
I_{DD}	Supply current	$SHUTDOWN = 2\text{ V}$		3.2	4.8	mA
$I_{DD(SD)}$	Supply current, shutdown mode	$SHUTDOWN = 0\text{ V}$		1	10	μA

operating characteristics, $V_{DD} = 5\text{ V}$, $T_A = 25^\circ\text{C}$, $R_L = 8\ \Omega$, $f = 1\text{ kHz}$ (unless otherwise noted)

PARAMETER		TEST CONDITIONS		MIN	TYP	MAX	UNIT
P_O	Output power (see Note 1)	THD = 0.1%,	BTL mode		1		W
		THD = 0.1%,	SE mode, $R_L = 32\ \Omega$		85		mW
THD + N	Total harmonic distortion plus noise	$P_O = 1\text{ W}$,	$f = 20\text{ Hz}$ to 20 kHz		0.33%		
BOM	Maximum output power bandwidth	Gain = 8 dB,	THD = 2%		20		kHz
	Supply ripple rejection ratio	$f = 1\text{ kHz}$,	$C_{(BYP)} = 0.47\ \mu\text{F}$	BTL mode	46		dB
				SE mode	60		
V_n	Noise output voltage	$C_{(BYP)} = 0.47\ \mu\text{F}$,	$f = 20\text{ Hz}$ to 20 kHz	BTL mode	85		μVRMS
				SE mode	34		

NOTE 1: Output power is measured at the output terminals of the device at $f = 1\text{ kHz}$.

PACKAGING INFORMATION

Orderable Device	Status (1)	Package Type	Package Drawing	Pins	Package Qty	Eco Plan (2)	Lead/Ball Finish	MSL Peak Temp (3)	Op Temp (°C)	Top-Side Markings (4)	Samples
TPA0253DGQ	ACTIVE	MSOP-PowerPAD	DGQ	10	80	Green (RoHS & no Sb/Br)	CU NIPDAU	Level-1-260C-UNLIM	-40 to 85	AEL	Samples
TPA0253DGQG4	ACTIVE	MSOP-PowerPAD	DGQ	10	80	Green (RoHS & no Sb/Br)	CU NIPDAU	Level-1-260C-UNLIM	-40 to 85	AEL	Samples
TPA0253DGQR	ACTIVE	MSOP-PowerPAD	DGQ	10	2500	Green (RoHS & no Sb/Br)	CU NIPDAU	Level-1-260C-UNLIM	-40 to 85	AEL	Samples
TPA0253DGQRG4	ACTIVE	MSOP-PowerPAD	DGQ	10	2500	Green (RoHS & no Sb/Br)	CU NIPDAU	Level-1-260C-UNLIM	-40 to 85	AEL	Samples

(1) The marketing status values are defined as follows:

ACTIVE: Product device recommended for new designs.

LIFEBUY: TI has announced that the device will be discontinued, and a lifetime-buy period is in effect.

NRND: Not recommended for new designs. Device is in production to support existing customers, but TI does not recommend using this part in a new design.

PREVIEW: Device has been announced but is not in production. Samples may or may not be available.

OBSELETE: TI has discontinued the production of the device.

(2) Eco Plan - The planned eco-friendly classification: Pb-Free (RoHS), Pb-Free (RoHS Exempt), or Green (RoHS & no Sb/Br) - please check <http://www.ti.com/productcontent> for the latest availability information and additional product content details.

TBD: The Pb-Free/Green conversion plan has not been defined.

Pb-Free (RoHS): TI's terms "Lead-Free" or "Pb-Free" mean semiconductor products that are compatible with the current RoHS requirements for all 6 substances, including the requirement that lead not exceed 0.1% by weight in homogeneous materials. Where designed to be soldered at high temperatures, TI Pb-Free products are suitable for use in specified lead-free processes.

Pb-Free (RoHS Exempt): This component has a RoHS exemption for either 1) lead-based flip-chip solder bumps used between the die and package, or 2) lead-based die adhesive used between the die and leadframe. The component is otherwise considered Pb-Free (RoHS compatible) as defined above.

Green (RoHS & no Sb/Br): TI defines "Green" to mean Pb-Free (RoHS compatible), and free of Bromine (Br) and Antimony (Sb) based flame retardants (Br or Sb do not exceed 0.1% by weight in homogeneous material)

(3) MSL, Peak Temp. -- The Moisture Sensitivity Level rating according to the JEDEC industry standard classifications, and peak solder temperature.

(4) Multiple Top-Side Markings will be inside parentheses. Only one Top-Side Marking contained in parentheses and separated by a "~" will appear on a device. If a line is indented then it is a continuation of the previous line and the two combined represent the entire Top-Side Marking for that device.

Important Information and Disclaimer: The information provided on this page represents TI's knowledge and belief as of the date that it is provided. TI bases its knowledge and belief on information provided by third parties, and makes no representation or warranty as to the accuracy of such information. Efforts are underway to better integrate information from third parties. TI has taken and continues to take reasonable steps to provide representative and accurate information but may not have conducted destructive testing or chemical analysis on incoming materials and chemicals. TI and TI suppliers consider certain information to be proprietary, and thus CAS numbers and other limited information may not be available for release.

In no event shall TI's liability arising out of such information exceed the total purchase price of the TI part(s) at issue in this document sold by TI to Customer on an annual basis.

TAPE AND REEL INFORMATION

QUADRANT ASSIGNMENTS FOR PIN 1 ORIENTATION IN TAPE

*All dimensions are nominal

Device	Package Type	Package Drawing	Pins	SPQ	Reel Diameter (mm)	Reel Width W1 (mm)	A0 (mm)	B0 (mm)	K0 (mm)	P1 (mm)	W (mm)	Pin1 Quadrant
TPA0253DGQR	MSOP-Power PAD	DGQ	10	2500	330.0	12.4	5.3	3.4	1.4	8.0	12.0	Q1

TAPE AND REEL BOX DIMENSIONS



*All dimensions are nominal

Device	Package Type	Package Drawing	Pins	SPQ	Length (mm)	Width (mm)	Height (mm)
TPA0253DGQR	MSOP-PowerPAD	DGQ	10	2500	358.0	335.0	35.0

DGQ (S-PDSO-G10)

PowerPAD™ PLASTIC SMALL OUTLINE

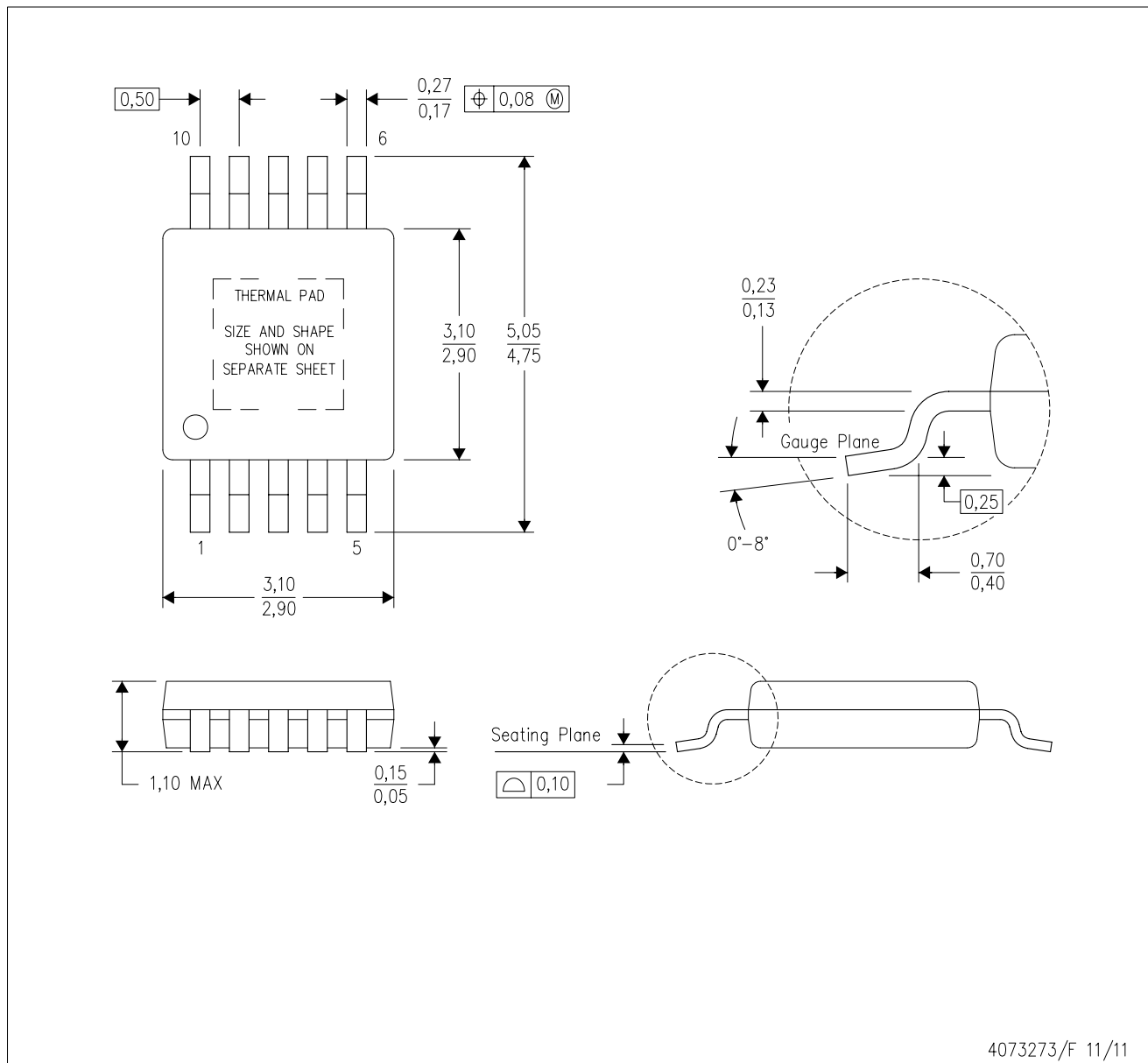

4073273/F 11/11

- NOTES:
- A. All linear dimensions are in millimeters.
 - B. This drawing is subject to change without notice.
 - C. Body dimensions do not include mold flash or protrusion not to exceed 0,15.
 - D. This package is designed to be soldered to a thermal pad on the board. Refer to Technical Brief, PowerPad Thermally Enhanced Package, Texas Instruments Literature No. SLMA002 for information regarding recommended board layout. This document is available at www.ti.com <<http://www.ti.com>>.
 - E. See the additional figure in the Product Data Sheet for details regarding the exposed thermal pad features and dimensions.
 - F. Falls within JEDEC MO-187 variation BA-T.

PowerPAD is a trademark of Texas Instruments.

DGQ (S-PDSO-G10)

PowerPAD™ PLASTIC SMALL OUTLINE

THERMAL INFORMATION

This PowerPAD™ package incorporates an exposed thermal pad that is designed to be attached to a printed circuit board (PCB). The thermal pad must be soldered directly to the PCB. After soldering, the PCB can be used as a heatsink. In addition, through the use of thermal vias, the thermal pad can be attached directly to the appropriate copper plane shown in the electrical schematic for the device, or alternatively, can be attached to a special heatsink structure designed into the PCB. This design optimizes the heat transfer from the integrated circuit (IC).

For additional information on the PowerPAD package and how to take advantage of its heat dissipating abilities, refer to Technical Brief, PowerPAD Thermally Enhanced Package, Texas Instruments Literature No. SLMA002 and Application Brief, PowerPAD Made Easy, Texas Instruments Literature No. SLMA004. Both documents are available at www.ti.com.

The exposed thermal pad dimensions for this package are shown in the following illustration.

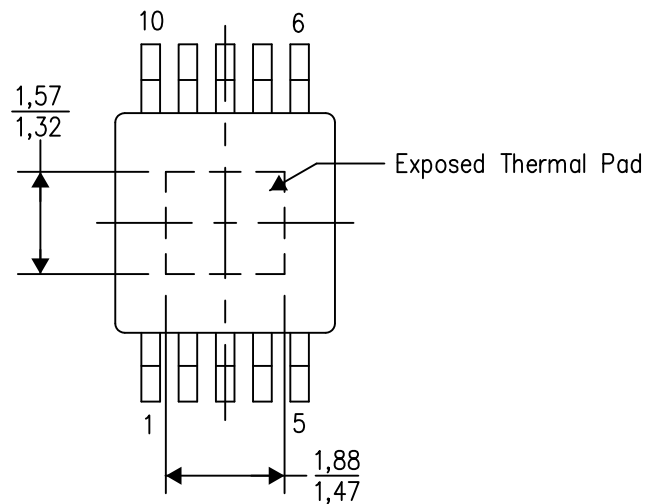

Top View

Exposed Thermal Pad Dimensions

4206324-2/H 12/14

NOTE: A. All linear dimensions are in millimeters

PowerPAD is a trademark of Texas Instruments

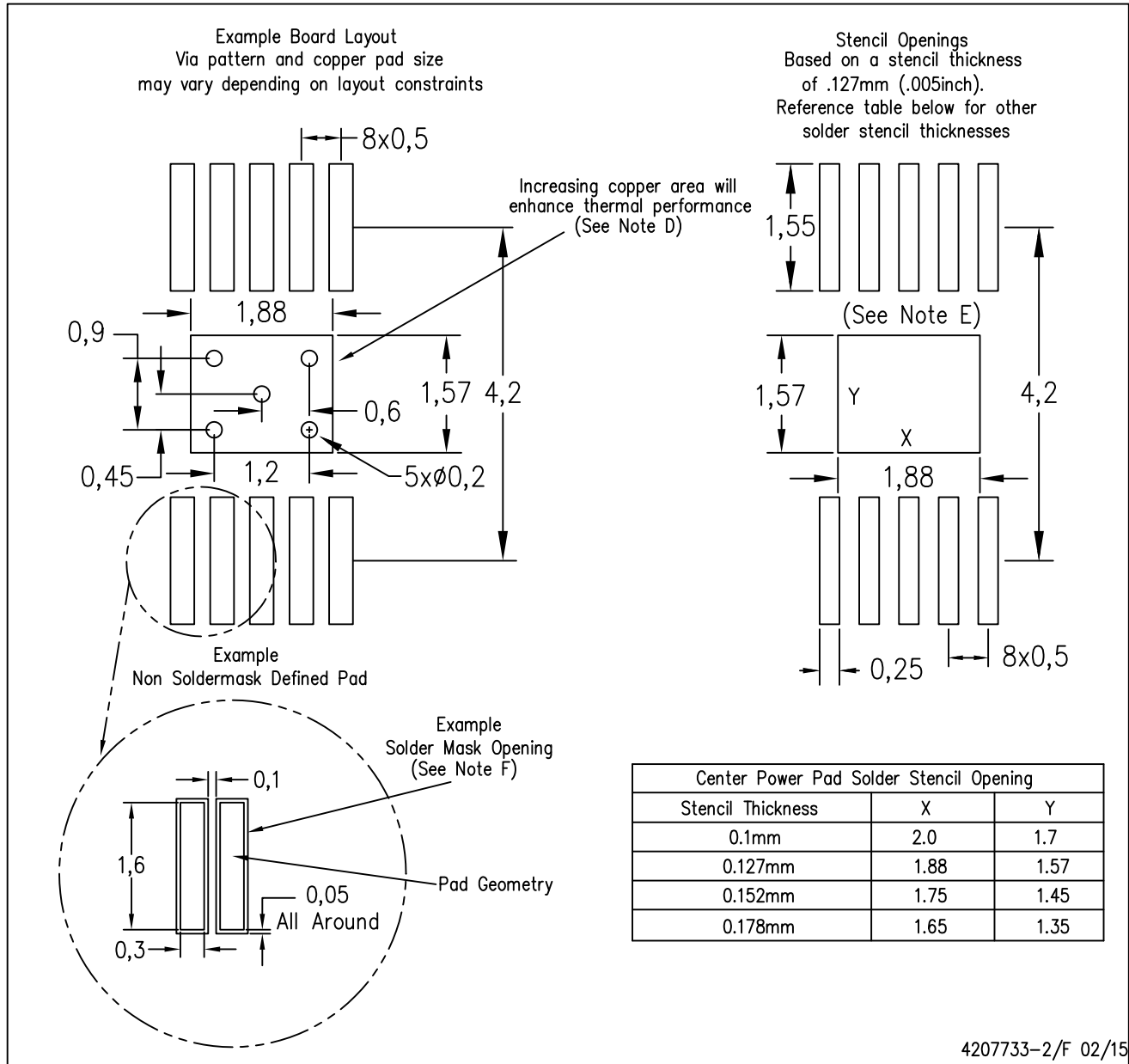

- NOTES:
- All linear dimensions are in millimeters.
 - This drawing is subject to change without notice.
 - Customers should place a note on the circuit board fabrication drawing not to alter the center solder mask defined pad.
 - This package is designed to be soldered to a thermal pad on the board. Refer to Technical Brief, PowerPad Thermally Enhanced Package, Texas Instruments Literature No. SLMA002, SLMA004, and also the Product Data Sheets for specific thermal information, via requirements, and recommended board layout. These documents are available at www.ti.com <<http://www.ti.com>>. Publication IPC-7351 is recommended for alternate designs.
 - Laser cutting apertures with trapezoidal walls and also rounding corners will offer better paste release. Customers should contact their board assembly site for stencil design recommendations. Example stencil design based on a 50% volumetric metal load solder paste. Refer to IPC-7525 for other stencil recommendations.
 - Customers should contact their board fabrication site for solder mask tolerances between and around signal pads.

PowerPAD is a trademark of Texas Instruments

IMPORTANT NOTICE AND DISCLAIMER

TI PROVIDES TECHNICAL AND RELIABILITY DATA (INCLUDING DATASHEETS), DESIGN RESOURCES (INCLUDING REFERENCE DESIGNS), APPLICATION OR OTHER DESIGN ADVICE, WEB TOOLS, SAFETY INFORMATION, AND OTHER RESOURCES "AS IS" AND WITH ALL FAULTS, AND DISCLAIMS ALL WARRANTIES, EXPRESS AND IMPLIED, INCLUDING WITHOUT LIMITATION ANY IMPLIED WARRANTIES OF MERCHANTABILITY, FITNESS FOR A PARTICULAR PURPOSE OR NON-INFRINGEMENT OF THIRD PARTY INTELLECTUAL PROPERTY RIGHTS.

These resources are intended for skilled developers designing with TI products. You are solely responsible for (1) selecting the appropriate TI products for your application, (2) designing, validating and testing your application, and (3) ensuring your application meets applicable standards, and any other safety, security, or other requirements. These resources are subject to change without notice. TI grants you permission to use these resources only for development of an application that uses the TI products described in the resource. Other reproduction and display of these resources is prohibited. No license is granted to any other TI intellectual property right or to any third party intellectual property right. TI disclaims responsibility for, and you will fully indemnify TI and its representatives against, any claims, damages, costs, losses, and liabilities arising out of your use of these resources.

TI's products are provided subject to TI's Terms of Sale (www.ti.com/legal/termsofsale.html) or other applicable terms available either on ti.com or provided in conjunction with such TI products. TI's provision of these resources does not expand or otherwise alter TI's applicable warranties or warranty disclaimers for TI products.

Mailing Address: Texas Instruments, Post Office Box 655303, Dallas, Texas 75265
Copyright © 2019, Texas Instruments Incorporated

Looking for pricing, stock, or lifecycle information?

Click below to explore more details on WIN SOURCE:

 [View TPA0253DGQ](#) on WIN SOURCE

 [Texas Instruments](#) Information

Optimize Your Supply Chain with WIN SOURCE Solutions

-  Global Sourcing Solution
-  Obsolete Management
-  Cost Control Management
-  Shortage Management
-  Alternative Solution
-  Excess Inventory Management