



**THE DATASHEET OF
TPA0211DGN**



TPA0211 2-W Mono Audio Power Amplifier

1 Features

- 2 W Into 4 Ω From 5-V Supply
- 0.6 W Into 4 Ω From 3-V Supply
- Wide Power Supply Compatibility: 3 V to 5 V
- Low Supply Current:
 - 4 mA Typical at 5 V
 - 4 mA Typical at 3 V
- Shutdown Control: 1 μ A Typical
- Shutdown Pin Is TTL Compatible
- -40°C to 85°C Operating Temperature Range
- Space-Saving, Thermally-Enhanced MSOP-PowerPAD™ Packaging

2 Applications

- Wireless Communicators
- Notebook PCs
- PDAs
- Other Small Portable Audio Devices

3 Description

The TPA0211 is a 2-W mono bridge-tied-load (BTL) amplifier designed to drive speakers with as low as 4- Ω impedance. The device is ideal for small wireless communicators, notebook PCs, PDAs, anyplace a mono speaker and stereo headphones are required. From a 5-V supply, the TPA0211 can deliver 2 W of power into a 4- Ω speaker.

The gain of the input stage is set by the user-selected input resistor and a 50-k Ω internal feedback resistor ($A_V = -R_F / R_I$). The power stage is internally configured with a gain of -1.25 V/V in SE mode, and -2.5 V/V in BTL mode. Thus, the overall gain of the amplifier is -62.5 k Ω / R_I in SE mode and -125 k Ω / R_I in BTL mode. The input terminals are high-impedance CMOS inputs, and can be used as summing nodes.

The TPA0211 is available in the 8-pin thermally-enhanced MSOP-PowerPAD package (DGN) and operates over an ambient temperature range of -40°C to 85°C .

Device Information⁽¹⁾

| PART NUMBER | PACKAGE | BODY SIZE (NOM) |
|-------------|-------------------|-------------------|
| TPA0211 | MSOP-PowerPAD (8) | 3.00 mm x 3.00 mm |

(1) For all available packages, see the orderable addendum at the end of the data sheet.

Simplified Application Schematic

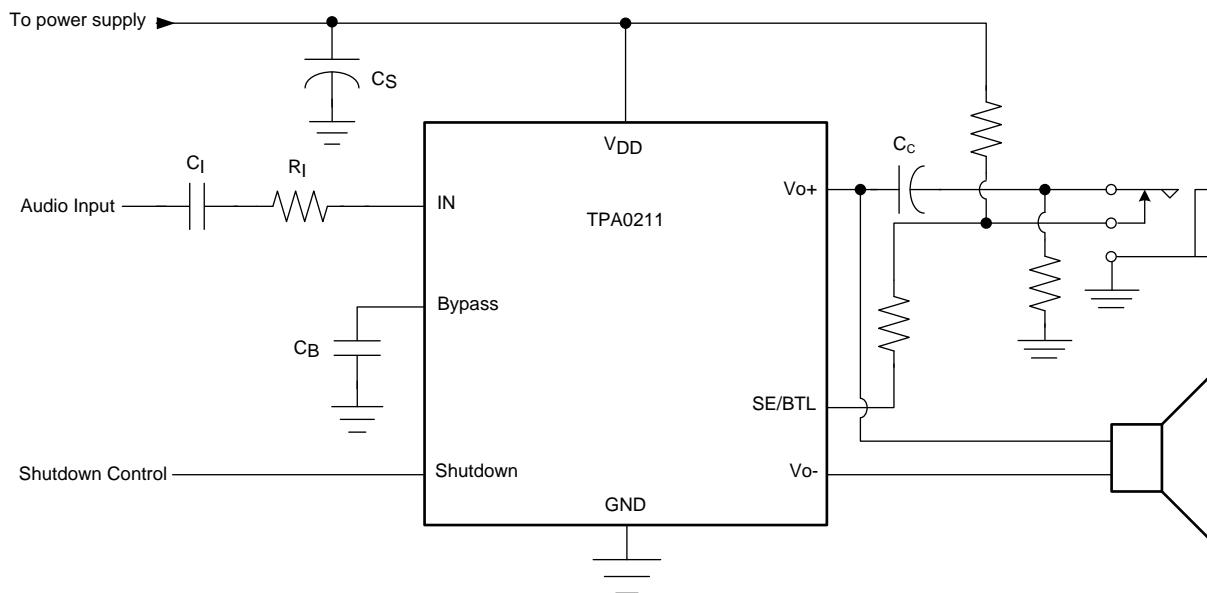

Copyright © 2016, Texas Instruments Incorporated



Table of Contents

| | | | |
|--|-----------|--|-----------|
| 1 Features | 1 | 9.3 Feature Description | 13 |
| 2 Applications | 1 | 9.4 Device Functional Modes | 17 |
| 3 Description | 1 | 10 Application and Implementation | 19 |
| 4 Revision History | 2 | 10.1 Application Information | 19 |
| 5 Device Comparison Table | 3 | 10.2 Typical Application | 19 |
| 6 Pin Configuration and Functions | 3 | 11 Power Supply Recommendations | 23 |
| 7 Specifications | 4 | 11.1 Power Supply Decoupling Capacitors | 23 |
| 7.1 Absolute Maximum Ratings | 4 | 12 Layout | 23 |
| 7.2 ESD Ratings | 4 | 12.1 Layout Guidelines | 23 |
| 7.3 Recommended Operating Conditions | 4 | 12.2 Layout Example | 23 |
| 7.4 Thermal Information | 4 | 12.3 Thermal Considerations | 24 |
| 7.5 Electrical Characteristics – 3 V | 5 | 13 Device and Documentation Support | 25 |
| 7.6 Electrical Characteristics – 5 V | 6 | 13.1 Documentation Support | 25 |
| 7.7 Dissipation Ratings | 6 | 13.2 Receiving Notification of Documentation Updates | 25 |
| 7.8 Typical Characteristics | 7 | 13.3 Community Resources | 25 |
| 8 Parameter Measurement Information | 11 | 13.4 Trademarks | 25 |
| 8.1 Set-Up for Graphs | 11 | 13.5 Electrostatic Discharge Caution | 25 |
| 9 Detailed Description | 12 | 13.6 Glossary | 25 |
| 9.1 Overview | 12 | 14 Mechanical, Packaging, and Orderable Information | 25 |
| 9.2 Functional Block Diagram | 12 | | |

4 Revision History

NOTE: Page numbers for previous revisions may differ from page numbers in the current version.

| Changes from Revision D (November 2002) to Revision E | Page |
|---|-------------|
| <ul style="list-style-type: none"> • Added <i>ESD Ratings</i> table, <i>Feature Description</i> section, <i>Device Functional Modes</i>, <i>Application and Implementation</i> section, <i>Power Supply Recommendations</i> section, <i>Layout</i> section, <i>Device and Documentation Support</i> section, and <i>Mechanical, Packaging, and Orderable Information</i> section | 1 |

5 Device Comparison Table

| DEVICE NUMBER | SPEAKER AMP TYPE | SPECIAL FEATURE | OUTPUT POWER (W) | PSRR (dB) |
|-------------------------|------------------|-----------------|------------------|-----------|
| TPA0211 | Class AB | — | 2 | 58 |
| TPA0213 | Class AB | — | 2 | 65 |
| TPA0233 | Class AB | — | 2 | 58 |
| TPA0253 | Class AB | — | 1 | 65 |

6 Pin Configuration and Functions

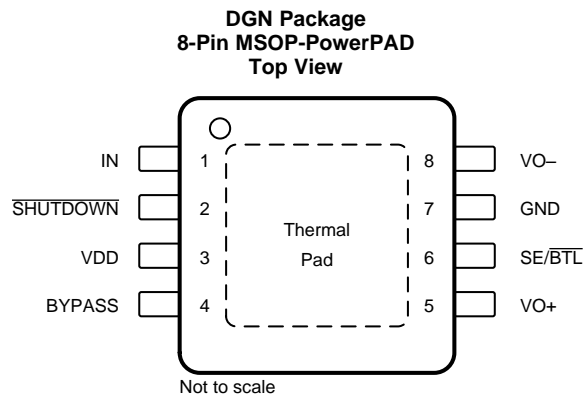

Pin Functions

| PIN | | I/O | DESCRIPTION |
|-----------------|-----|-----|---|
| NAME | NO. | | |
| BYPASS | 4 | I | BYPASS is the tap to the voltage divider for internal mid-supply bias. This terminal must be connected to a 0.1- μ F to 1- μ F capacitor. |
| GND | 7 | — | GND is the ground connection. |
| IN | 1 | I | IN is the audio input terminal. |
| SE/BTL | 6 | I | When SE/BTL is held low, the TPA0211 is in BTL mode. When SE/BTL is held high, the TPA0211 is in SE mode. |
| SHUTDOWN | 2 | I | SHUTDOWN places the entire device in shutdown mode when held low. TTL compatible input. |
| V _{DD} | 3 | — | V _{DD} is the supply voltage terminal. |
| V _{O+} | 5 | O | V _{O+} is the positive output for BTL and SE modes. |
| V _{O-} | 8 | O | V _{O-} is the negative output in BTL mode and a high-impedance output in SE mode. |

7 Specifications

7.1 Absolute Maximum Ratings

 over operating free-air temperature range (unless otherwise noted)⁽¹⁾

| | MIN | MAX | UNIT |
|---|--|----------------|------|
| Supply voltage, V_{DD} | | 6 | V |
| Input voltage, V_I | -0.3 | $V_{DD} + 0.3$ | V |
| Continuous total power dissipation | Internally limited (see Dissipation Ratings) | | |
| Lead temperature, 1.6 mm (1/16 inch) from case (10 s) | | 260 | °C |
| Operating junction temperature, T_J | -40 | 150 | °C |
| Storage temperature, T_{stg} | -65 | 150 | °C |

(1) Stresses beyond those listed under *Absolute Maximum Ratings* may cause permanent damage to the device. These are stress ratings only, which do not imply functional operation of the device at these or any other conditions beyond those indicated under *Recommended Operating Conditions*. Exposure to absolute-maximum-rated conditions for extended periods may affect device reliability.

7.2 ESD Ratings

| | | VALUE | UNIT |
|-------------------------------------|--|-------|------|
| $V_{(ESD)}$ Electrostatic discharge | Human-body model (HBM), per ANSI/ESDA/JEDEC JS-001 ⁽¹⁾ | ±4000 | V |
| | Charged-device model (CDM), per JEDEC specification JESD22-C101 ⁽²⁾ | ±1000 | |

(1) JEDEC document JEP155 states that 500-V HBM allows safe manufacturing with a standard ESD control process.

(2) JEDEC document JEP157 states that 250-V CDM allows safe manufacturing with a standard ESD control process.

7.3 Recommended Operating Conditions

over operating free-air temperature range (unless otherwise noted)

| | | | | MIN | NOM | MAX | UNIT |
|----------|--------------------------------|----------|-----------------------|-----|-----|------|------|
| V_{DD} | Supply voltage | | | 2.5 | | 5.5 | V |
| V_{IH} | High-level input voltage | SE/BTL | $V_{DD} = 3\text{ V}$ | 2.7 | | | V |
| | | | $V_{DD} = 5\text{ V}$ | 4.5 | | | |
| | | SHUTDOWN | | 2 | | | |
| V_{IL} | Low-level input voltage | SE/BTL | $V_{DD} = 3\text{ V}$ | | | 1.65 | V |
| | | | $V_{DD} = 5\text{ V}$ | | | 2.75 | |
| | | SHUTDOWN | | | | 0.8 | |
| T_A | Operating free-air temperature | | | -40 | | 85 | °C |

7.4 Thermal Information

| THERMAL METRIC ⁽¹⁾ | | TPA0211 | UNIT |
|-------------------------------|--|---------------------|------|
| | | DGN (MSOP-PowerPAD) | |
| | | 8 PINS | |
| $R_{\theta JA}$ | Junction-to-ambient thermal resistance | 51.9 | °C/W |
| $R_{\theta JC(top)}$ | Junction-to-case (top) thermal resistance | 41.9 | °C/W |
| $R_{\theta JB}$ | Junction-to-board thermal resistance | 30.5 | °C/W |
| Ψ_{JT} | Junction-to-top characterization parameter | 1.5 | °C/W |
| Ψ_{JB} | Junction-to-board characterization parameter | 30.2 | °C/W |
| $R_{\theta JC(bot)}$ | Junction-to-case (bottom) thermal resistance | 6 | °C/W |

(1) For more information about traditional and new thermal metrics, see the [Semiconductor and IC Package Thermal Metrics](#) application report.

7.5 Electrical Characteristics – 3 V

 $V_{DD} = 3\text{ V}$ and $T_A = 25^\circ\text{C}$ (unless otherwise noted)

| PARAMETER | | TEST CONDITIONS | | MIN | TYP | MAX | UNIT |
|--|---|---|---|-----|------|-----|---------------------|
| $ V_{OO} $ | Output offset voltage (measured differentially) | $\overline{SE/BTL} = 0\text{ V}$, $\overline{SHUTDOWN} = 2\text{ V}$, $R_L = 8\ \Omega$, inputs floating | | | | 30 | mV |
| $I_{DD(BTL)}$ | Supply current, BTL mode | $\overline{SE/BTL} = 1.375\text{ V}$, $\overline{SHUTDOWN} = 2\text{ V}$, $V_{DD} = 2.5\text{ V}$ | | | 4 | 6 | mA |
| $I_{DD(SE)}$ | Supply current, SE mode | $\overline{SE/BTL} = 2.25\text{ V}$, $\overline{SHUTDOWN} = 2\text{ V}$, $V_{DD} = 2.5\text{ V}$ | | | 2 | 4 | mA |
| $I_{DD(SD)}$ | Supply current, shutdown mode | $\overline{SE/BTL} = 3\text{ V}$, $\overline{SHUTDOWN} = 0\text{ V}$ | | | 1 | 10 | μA |
| $ I_{IH} $ | High-level input current | $V_{DD} = 3.3\text{ V}$, $V_I = V_{DD}$ | $\overline{SHUTDOWN}$ | | | 1 | μA |
| | | | $\overline{SE/BTL}$ | | | 1 | |
| $ I_{IL} $ | Low-level input current | $V_{DD} = 3.3\text{ V}$, $V_I = 0\text{ V}$ | $\overline{SHUTDOWN}$ | | | 1 | μA |
| | | | $\overline{SE/BTL}$ | | | 1 | |
| R_F | Feedback resistor | $\overline{SE/BTL} = 0\text{ V}$, $\overline{SHUTDOWN} = 2\text{ V}$, $V_{DD} = 2.5\text{ V}$, $R_L = 4\ \Omega$ | | 45 | 50 | 60 | k Ω |
| OPERATING CHARACTERISTICS, $R_L = 4\ \Omega$ | | | | | | | |
| P_O | Output power | THD = 1%, BTL mode, $f = 1\text{ kHz}$ | | | 660 | | mW |
| | | THD = 0.1%, SE mode, $f = 1\text{ kHz}$, $R_L = 32\ \Omega$ | | | 33 | | |
| THD+N | Total harmonic distortion plus noise | $P_O = 500\text{ mW}$, $f = 20\text{ Hz to }20\text{ kHz}$ | | | 0.3% | | |
| B_{OM} | Maximum output power bandwidth | Gain = 2, THD = 2% | | | 20 | | kHz |
| SNR | Signal-to-noise ratio | | | | 88 | | dB |
| V_n | Output noise voltage | $C_B = 0.47\ \mu\text{F}$, $f = 20\text{ Hz to }20\text{ kHz}$ | BTL mode, $R_L = 8\ \Omega$, $A_V = 8\text{ dB}$ | | 65 | | μV_{RMS} |
| | | | SE mode, $R_L = 32\ \Omega$, $A_V = 2\text{ dB}$ | | 25 | | |

7.6 Electrical Characteristics – 5 V

 $V_{DD} = 5\text{ V}$ and $T_A = 25^\circ\text{C}$ (unless otherwise noted)

| PARAMETER | | TEST CONDITIONS | | MIN | TYP | MAX | UNIT |
|--|---|---|--|-----|------|-----|---------------------|
| $ V_{OO} $ | Output offset voltage (measured differentially) | $SE/\overline{BTL} = 0\text{ V}$, $\overline{SHUTDOWN} = 2\text{ V}$, $R_L = 8\ \Omega$, inputs floating | | | | 30 | mV |
| $I_{DD(BTL)}$ | Supply current, BTL mode | $SE/\overline{BTL} = 2.75\text{ V}$, $\overline{SHUTDOWN} = V_{DD}$ | | | 4 | 6 | mA |
| $I_{DD(SE)}$ | Supply current, SE mode | $SE/\overline{BTL} = 4.5\text{ V}$, $\overline{SHUTDOWN} = V_{DD}$ | | | 2 | 4 | mA |
| $I_{DD(SD)}$ | Supply current, shutdown mode | $SE/\overline{BTL} = 5\text{ V}$, $\overline{SHUTDOWN} = 0\text{ V}$ | | | 1 | 10 | μA |
| $ I_{IH} $ | High-level input current | $V_{DD} = 5.5\text{ V}$, $V_I = V_{DD}$ | $\overline{SHUTDOWN}$ | | | 1 | μA |
| | | | SE/\overline{BTL} | | | 1 | |
| $ I_{IL} $ | Low-level input current | $V_{DD} = 5.5\text{ V}$, $V_I = 0\text{ V}$ | $\overline{SHUTDOWN}$ | | | 1 | μA |
| | | | SE/\overline{BTL} | | | 1 | |
| OPERATING CHARACTERISTICS, $R_L = 4\ \Omega$ | | | | | | | |
| P_O | Output power | THD = 1%, BTL mode, $f = 1\text{ kHz}$ | | | 2 | | W |
| | | THD = 0.1%, SE mode, $f = 1\text{ kHz}$, $R_L = 32\ \Omega$ | | | 92 | | mW |
| THD+N | Total harmonic distortion plus noise | $P_O = 1.5\text{ W}$, $f = 20\text{ Hz to } 20\text{ kHz}$ | | | 0.2% | | |
| B_{OM} | Maximum output power bandwidth | Gain = 2.5, THD = 2% | | | 20 | | kHz |
| SNR | Signal-to-noise ratio | | | | 93 | | dB |
| V_n | Output noise voltage | $C_B = 0.47\ \mu\text{F}$, $f = 20\text{ Hz to } 20\text{ kHz}$ | BTL mode, $R_L = 8\ \Omega$, $A_V = 8\text{ dB}$ | | 65 | | μV_{RMS} |
| | | | SE mode, $R_L = 32\ \Omega$, $A_V = 2\text{ dB}$ | | 25 | | |

7.7 Dissipation Ratings

| PACKAGE | $T_A \leq 25^\circ\text{C}$ | DERATING FACTOR | $T_A = 70^\circ\text{C}$ | $T_A = 85^\circ\text{C}$ |
|---------|-----------------------------|-----------------|--------------------------|--------------------------|
| DGN | 2.14 W ⁽¹⁾ | 17.1 mW/°C | 1.37 W | 1.11 W |

- (1) See [PowerPAD™ Thermally Enhanced Package](#) (SLMA002) for more information on the PowerPAD™ package. The thermal data was measured on a PCB layout based on the information in the section entitled *Texas Instruments Recommended Board for PowerPAD* on page 33 of that document.

7.8 Typical Characteristics

Table 1. Table of Graphs

| | | | FIGURE |
|----------|--------------------------------------|--------------------|--|
| | Supply ripple rejection ratio | vs Frequency | Figure 1, Figure 2 |
| I_{DD} | Supply current | vs Supply voltage | Figure 3 |
| P_O | Output power | vs Supply voltage | Figure 4, Figure 5 |
| | | vs Load resistance | Figure 6, Figure 7 |
| THD+N | Total harmonic distortion plus noise | vs Frequency | Figure 8, Figure 9, Figure 10, Figure 11 |
| | | vs Output power | Figure 12, Figure 13, Figure 14, Figure 15, Figure 16, Figure 17 |
| V_n | Output noise voltage | vs Frequency | Figure 18, Figure 19 |
| | Closed loop gain and phase | | Figure 20, Figure 21 |

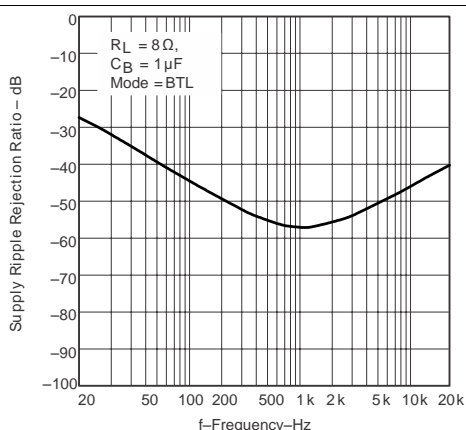

Figure 1. Supply Ripple Rejection Ratio vs Frequency

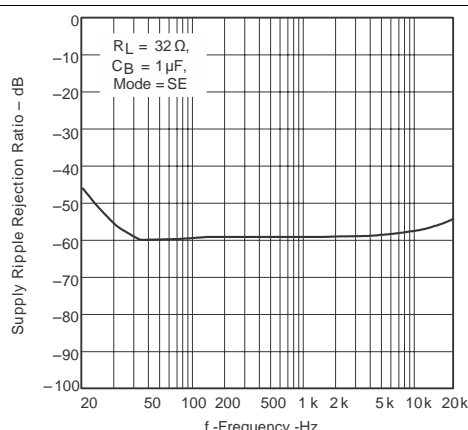

Figure 2. Supply Ripple Rejection Ratio vs Frequency

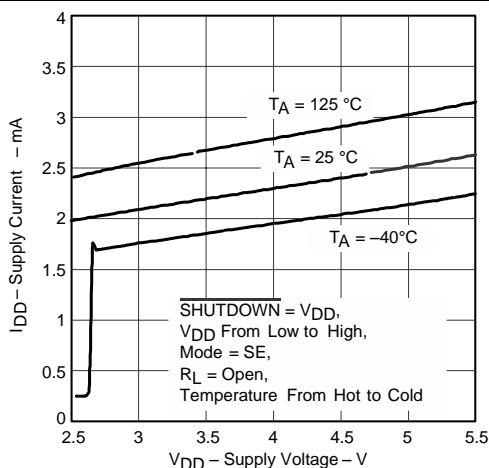

Figure 3. Supply Current vs Supply Voltage

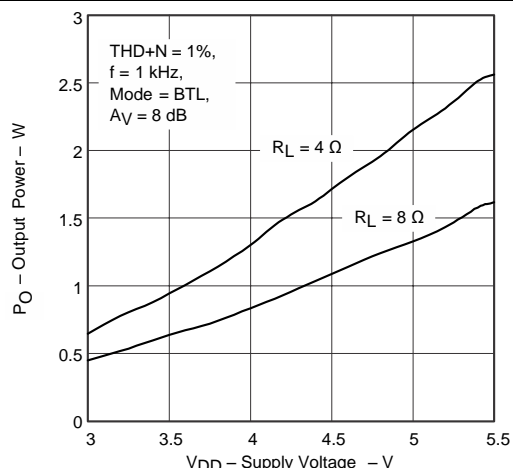

Figure 4. Output Power vs Supply Voltage

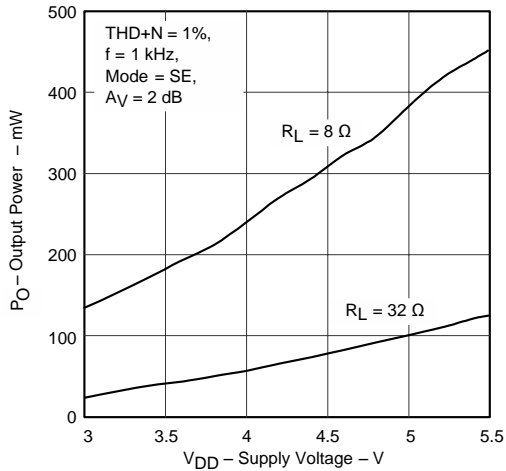

Figure 5. Output Power vs Supply Voltage

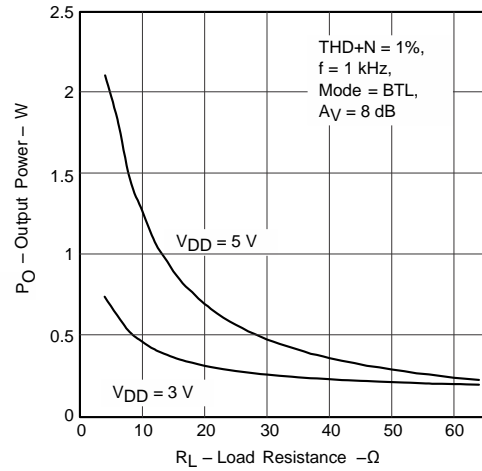

Figure 6. Output Power vs Load Resistance

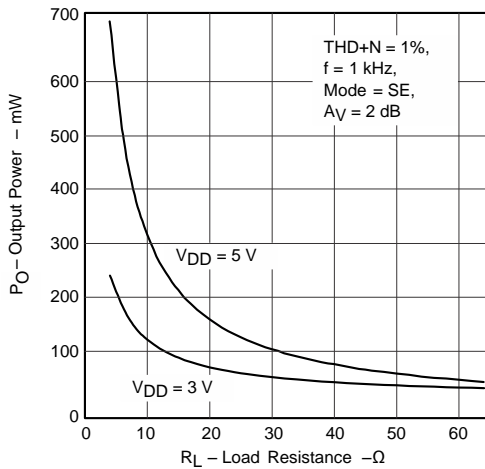

Figure 7. Output Power vs Load Resistance

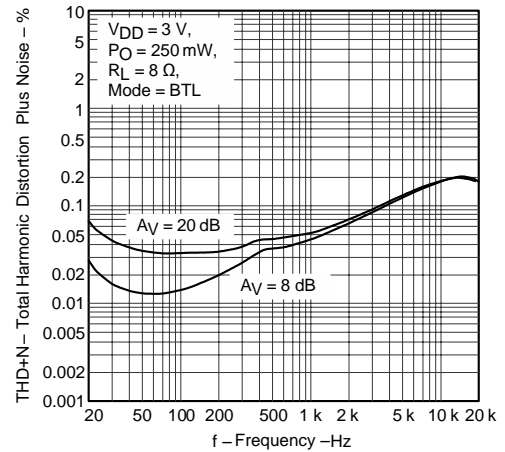

Figure 8. Total Harmonic Distortion Plus Noise vs Frequency

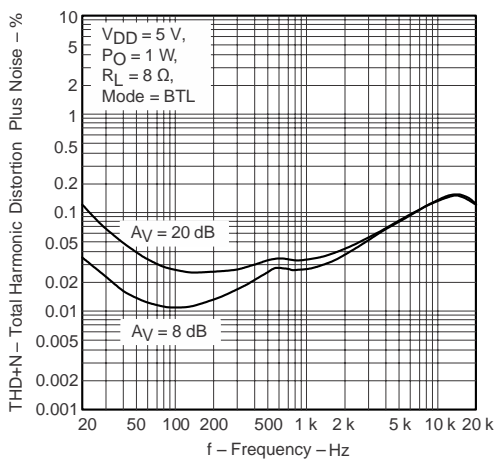

Figure 9. Total Harmonic Distortion Plus Noise vs Frequency

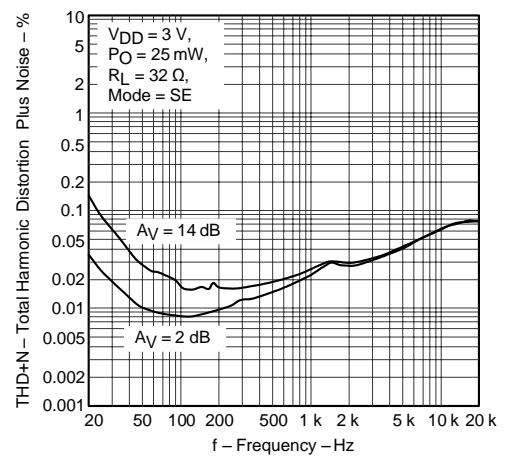

Figure 10. Total Harmonic Distortion Plus Noise vs Frequency

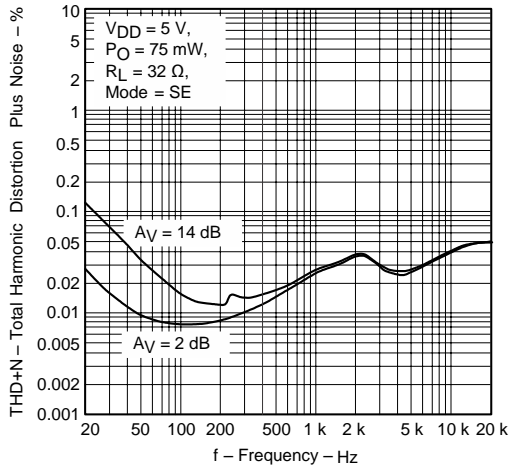

Figure 11. Total Harmonic Distortion Plus Noise vs Frequency

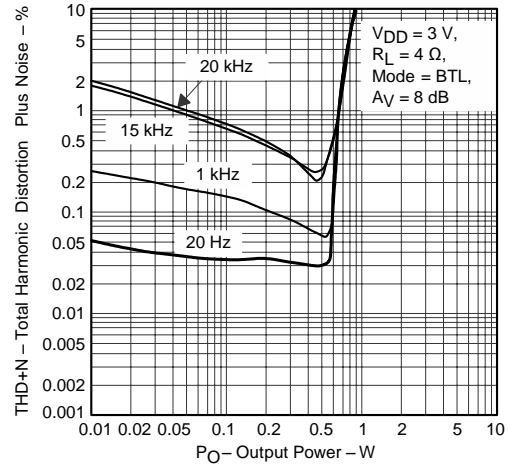

Figure 12. Total Harmonic Distortion Plus Noise vs Output Power

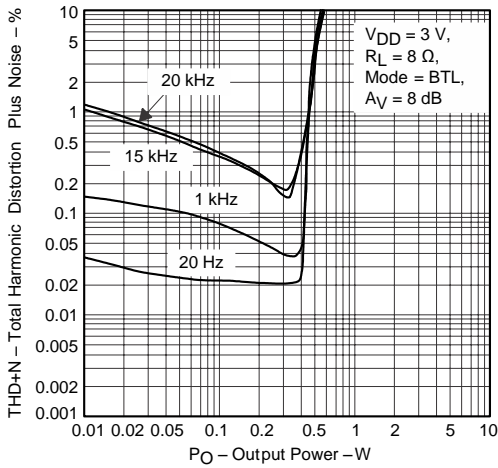

Figure 13. Total Harmonic Distortion Plus Noise vs Output Power

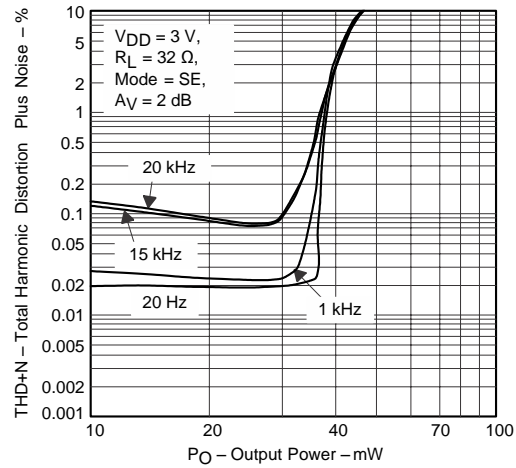

Figure 14. Total Harmonic Distortion Plus Noise vs Output Power

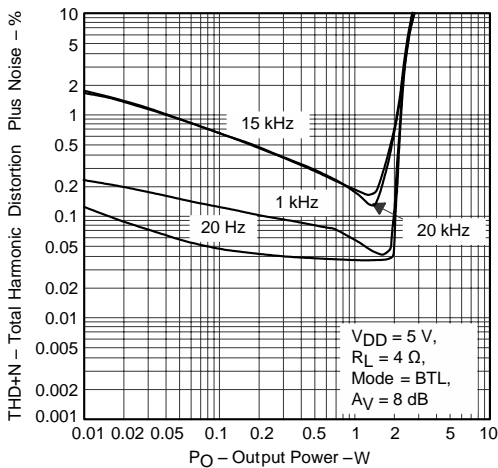

Figure 15. Total Harmonic Distortion Plus Noise vs Output Power

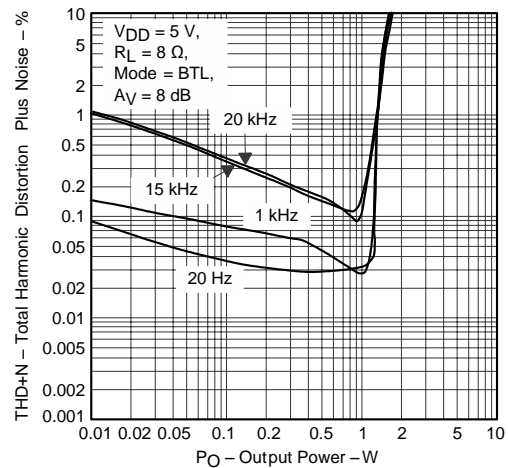

Figure 16. Total Harmonic Distortion Plus Noise vs Output Power

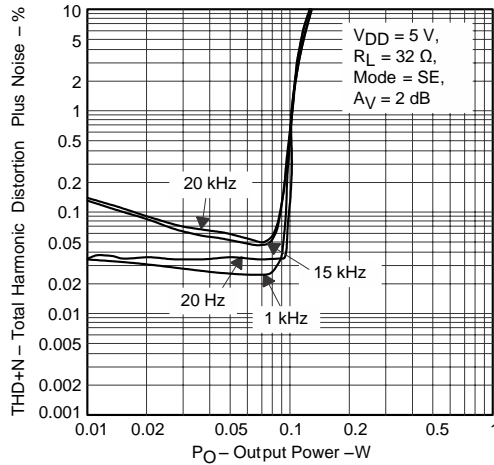

Figure 17. Total Harmonic Distortion Plus Noise vs Output Power

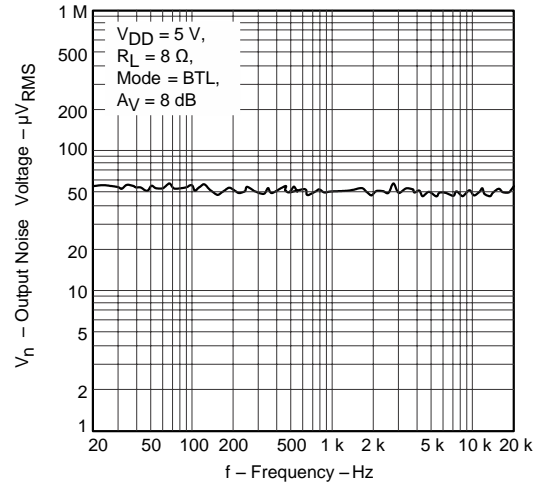

Figure 18. Output Noise Voltage vs Frequency

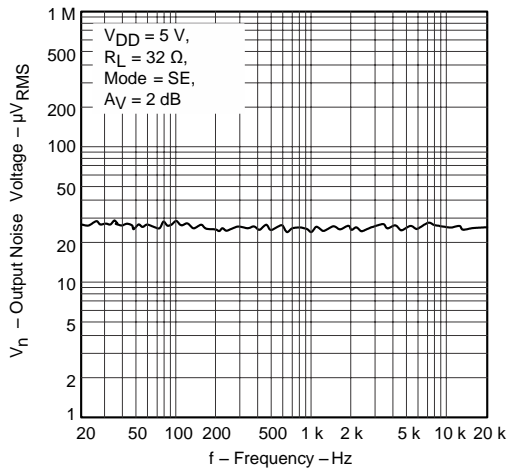

Figure 19. Output Noise Voltage vs Frequency

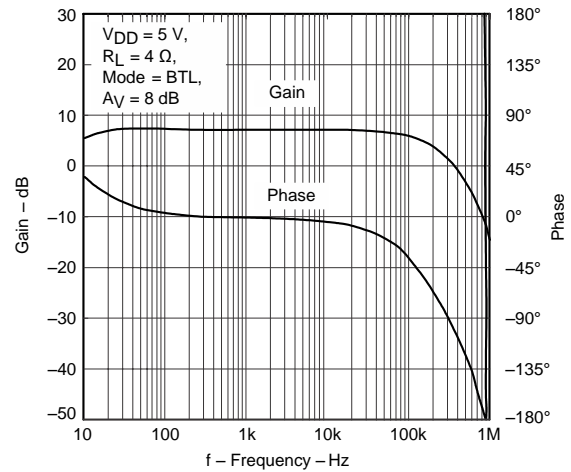

Figure 20. Closed Loop Response

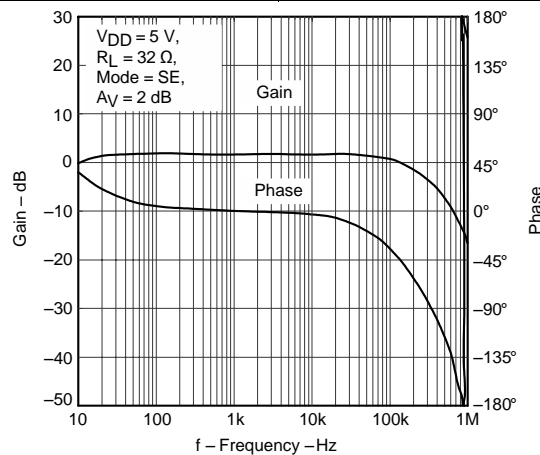
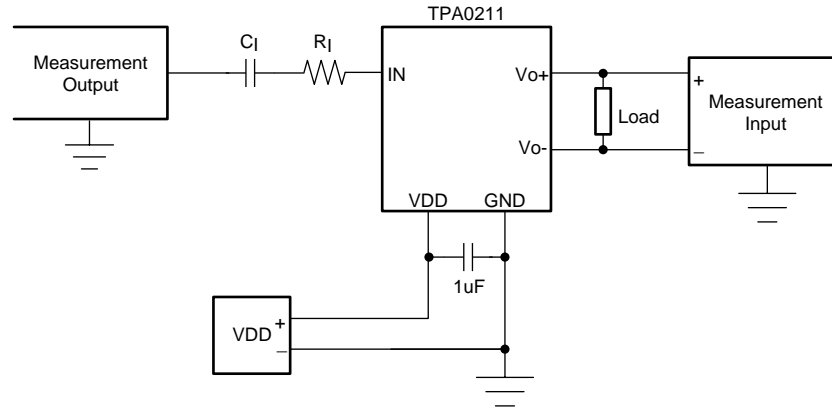

Figure 21. Closed Loop Response

8 Parameter Measurement Information

8.1 Set-Up for Graphs

All parameters are measured according to the conditions described in [Specifications](#). [Figure 22](#) shows the setup used for the typical characteristics of the test device.



Copyright © 2016, Texas Instruments Incorporated

- (1) All other measurements were taken with 1- μ F C_I (unless otherwise noted).
- (2) A 33- μ H inductor was placed in series with the load resistor to emulate a small speaker for efficiency measurements.

Figure 22. Test Set-Up for Graphs

9 Detailed Description

9.1 Overview

The TPA0211 device is a Class AB audio power amplifier designed to drive speakers in applications like small wireless communicators, cellphones, notebooks, and so forth. The TPA0211 can deliver 2 W (1% THD+N) of power into a 4- Ω speaker.

This device is available in the 8-pin thermally-enhanced MSOP-PowerPAD package (DGN) and operates over an ambient temperature range of -40°C to 85°C .

9.2 Functional Block Diagram

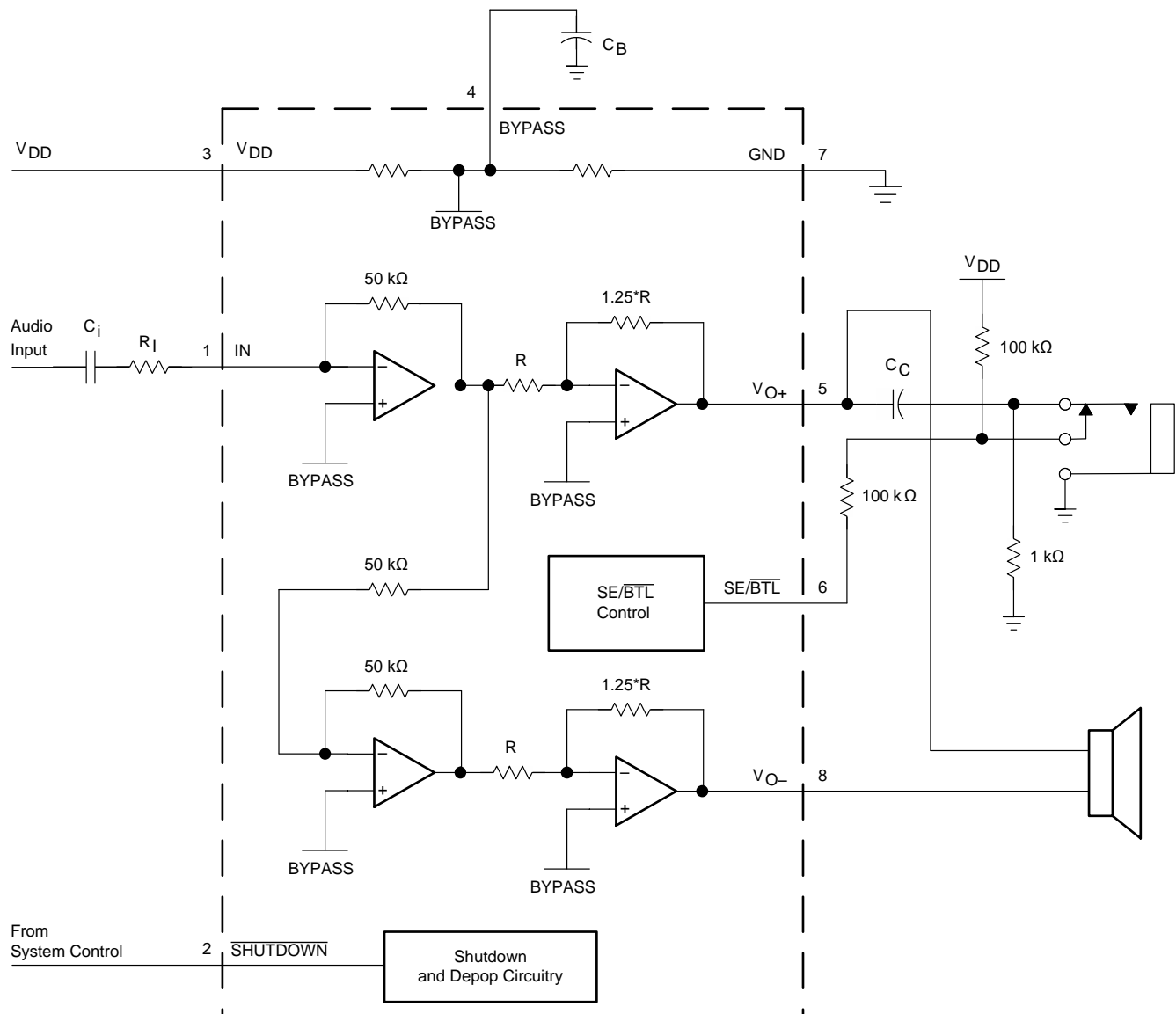

9.3 Feature Description

9.3.1 Bridged-Tied Load Versus Single-Ended Mode

Figure 23 shows a Class-AB audio power amplifier (APA) in a BTL configuration. The TPA0211 BTL amplifier consists of two Class-AB amplifiers driving both ends of the load. There are several potential benefits to this differential drive configuration, but initially consider power to the load. The differential drive to the speaker means that as one side is slewing up, the other side is slewing down, and vice versa. This, in effect, doubles the voltage swing on the load as compared to a ground referenced load. Plugging $2 \times V_{O(PP)}$ into the power equation, where voltage is squared, yields 4 times the output power from the same supply rail and load impedance (see Equation 1 and).

$$V_{(RMS)} = \frac{V_{O(PP)}}{2\sqrt{2}}$$

$$Power = \frac{V_{(RMS)}^2}{R_L} \tag{1}$$

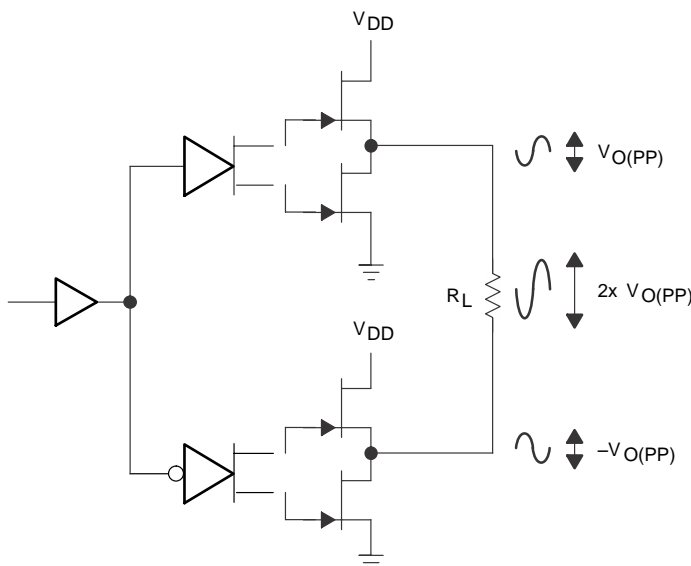

Figure 23. Bridge-Tied Load Configuration

In a typical computer sound channel operating at 5 V, bridging raises the power into an 8-Ω speaker from a singled-ended (SE, ground reference) limit of 250 mW to 1 W. In sound power, that is a 6-dB improvement — which is loudness that can be heard. In addition to increased power, there are frequency response concerns. Consider the single-supply SE configuration shown in Figure 24. A coupling capacitor is required to block the dc offset voltage from reaching the load. These capacitors can be quite large (approximately 33 μF to 1000 μF) so they tend to be expensive, heavy, occupy valuable PCB area, and have the additional drawback of limiting low-frequency performance of the system. This frequency limiting effect is due to the high pass filter network created with the speaker impedance and the coupling capacitance and is calculated with Equation 2.

$$f_c = \frac{1}{2\pi R_L C_{(C)}} \tag{2}$$

For example, a 68-μF capacitor with an 8-Ω speaker would attenuate low frequencies below 293 Hz. The BTL configuration cancels the dc offsets, which eliminates the need for the blocking capacitors. Low-frequency performance is then limited only by the input network and speaker response. Cost and PCB space are also minimized by eliminating the bulky coupling capacitor.

Feature Description (continued)

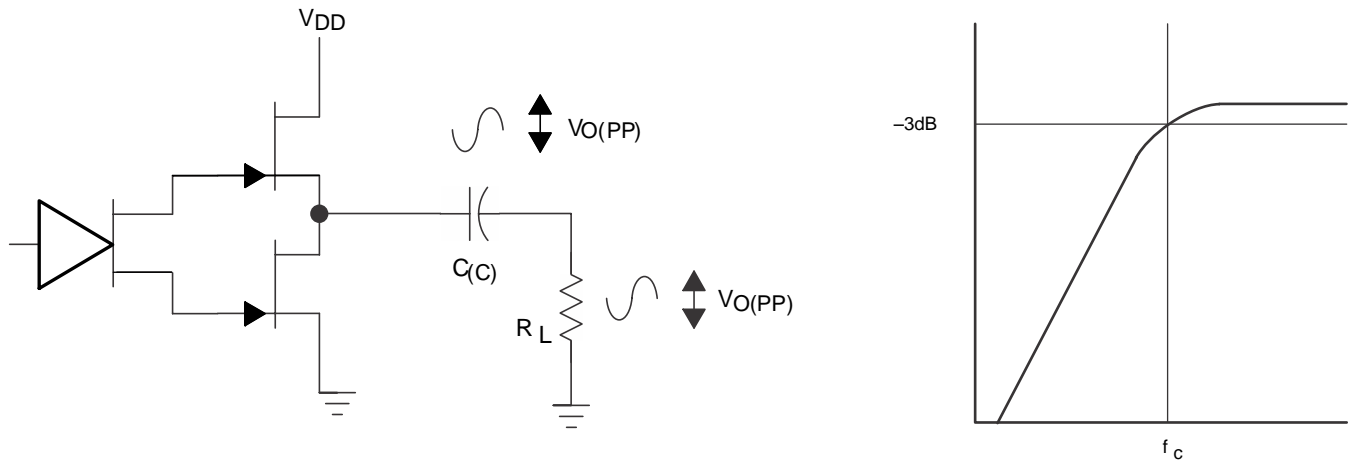

Figure 24. Single-Ended Configuration and Frequency Response

Increasing power to the load does carry a penalty of increased internal power dissipation. The increased dissipation is understandable considering that the BTL configuration produces 4 times the output power of the SE configuration. Internal dissipation versus output power is discussed further in [Crest Factor](#).

9.3.2 Single-Ended Operation

In SE mode (see [Figure 23](#) and [Figure 24](#)), the load is driven from one amplifier output (V_{O+} , terminal 5). The amplifier switches to single-ended operation when the SE/BTL terminal is held high.

9.3.3 BTL Amplifier Efficiency

Class-AB amplifiers are inefficient. The primary cause of inefficiencies is the voltage drop across the output stage transistors. There are two components of the internal voltage drop. One is the headroom or dc voltage drop that varies inversely to output power. The second component is due to the sinewave nature of the output. The total voltage drop can be calculated by subtracting the RMS value of the output voltage from V_{DD} . The internal voltage drop multiplied by the RMS value of the supply current, I_{DDrms} , determines the internal power dissipation of the amplifier.

An easy-to-use equation to calculate efficiency starts out as being equal to the ratio of power from the power supply to the power delivered to the load. To accurately calculate the RMS and average values of power in the load and in the amplifier, the current and voltage waveform shapes must first be understood (see [Figure 25](#)).

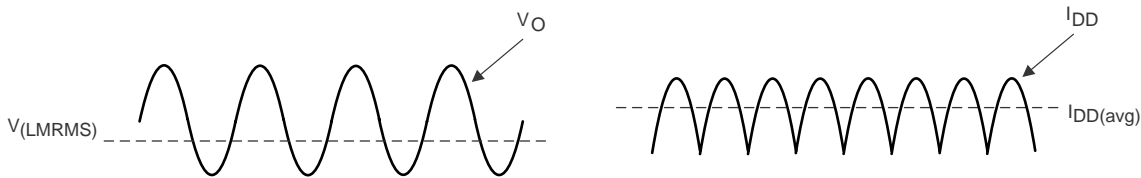

Figure 25. Voltage and Current Waveforms for BTL Amplifiers

Although the voltages and currents for SE and BTL are sinusoidal in the load, currents from the supply are very different between SE and BTL configurations. In an SE application the current waveform is a half-wave rectified shape, whereas in BTL it is a full-wave rectified waveform. This means RMS conversion factors are different. Keep in mind that for most of the waveform both the push and pull transistors are not on at the same time, which supports the fact that each amplifier in the BTL device only draws current from the supply for half the waveform. [Equation 3](#) and [Equation 4](#) are the basis for calculating amplifier efficiency.

Feature Description (continued)

$$\text{Efficiency of a BTL amplifier} = \frac{P_L}{P_{SUP}}$$

where

$$P_L = \frac{V_{LRMS}^2}{R_L}, \text{ and } V_{LRMS} = \frac{V_P}{\sqrt{2}}, \text{ therefore, } P_L = \frac{V_P^2}{2R_L}$$

$$\text{and } P_{SUP} = V_{DD} I_{DD\text{avg}} \text{ and } I_{DD\text{avg}} = \frac{1}{\pi} \int_0^{\pi} \frac{V_P}{R_L} \sin(t) dt = \frac{1}{\pi} \times \frac{V_P}{R_L} [\cos(t)]_0^{\pi} = \frac{2V_P}{\pi R_L}$$

therefore,

$$P_{SUP} = \frac{2V_{DD}V_P}{\pi R_L}$$

substituting P_L and P_{SUP} into equation 9,

$$\text{Efficiency of a BTL amplifier} = \frac{\frac{V_P^2}{2R_L}}{\frac{2V_{DD}V_P}{\pi R_L}} = \frac{\pi V_P}{4V_{DD}}$$

where

$$V_P = \sqrt{2P_L R_L} \tag{3}$$

therefore,

$$\eta_{BTL} = \frac{\pi \sqrt{2P_L R_L}}{4V_{DD}}$$

P_L = Power delivered to load

V_P = Peak voltage on BTL load

P_{SUP} = Power drawn from power supply

$I_{DD\text{avg}}$ = Average current drawn from the power supply

V_{LRMS} = RMS voltage on BTL load

V_{DD} = Power supply voltage

R_L = Load resistance

η_{BTL} = Efficiency of a BTL amplifier (4)

Table 2 employs [Equation 3](#) to calculate efficiencies for four different output power levels. Note that the efficiency of the amplifier is quite low for lower power levels and rises sharply as power to the load is increased resulting in a nearly flat internal power dissipation over the normal operating range. Note that the internal dissipation at full output power is less than in the half power range. Calculating the efficiency for a specific system is the key to proper power supply design.

Table 2. Efficiency vs Output Power in 5-V 8-Ω BTL Systems

| OUTPUT POWER (W) | EFFICIENCY (%) | PEAK VOLTAGE (V) | INTERNAL DISSIPATION (W) |
|------------------|----------------|---------------------|--------------------------|
| 0.25 | 31.4 | 2 | 0.55 |
| 0.5 | 44.4 | 2.83 | 0.62 |
| 1 | 62.8 | 4 | 0.59 |
| 1.25 | 70.2 | 4.47 ⁽¹⁾ | 0.53 |

(1) High peak voltages cause the THD to increase.

A final point to remember about Class-AB amplifiers (either SE or BTL) is how to manipulate the terms in the efficiency equation to utmost advantage when possible. Note that in [Equation 3](#), V_{DD} is in the denominator. This indicates that as V_{DD} goes down, efficiency goes up.

9.3.4 Gain Setting Via Input Resistance

The gain of the input stage is set by the user-selected input resistor and a 50-k Ω internal feedback resistor.

However, the power stage is internally configured with a gain of -1.25 V/V in SE mode, and -2.5 V/V in BTL mode. Thus, the feedback resistor (R_F) is effectively 62.5 k Ω in SE mode and 125 k Ω in BTL mode. Therefore, the overall gain can be calculated using [Equation 5](#) and [Equation 6](#).

$$A_V = \frac{-125\text{k}\Omega}{R_I} \quad (\text{BTL}) \quad (5)$$

$$A_V = \frac{-62.5\text{k}\Omega}{R_I} \quad (\text{SE}) \quad (6)$$

The -3 dB frequency can be calculated using [Equation 7](#).

$$f_{-3\text{db}} = \frac{1}{2\pi R_I C_i} \quad (7)$$

If the filter must be more accurate, the value of the capacitor should be increased while the value of the resistor to ground should be decreased. In addition, the order of the filter could be increased.

9.3.5 Crest Factor

Class-AB power amplifiers dissipate a significant amount of heat in the package under normal operating conditions. A typical music CD requires 12 dB to 15 dB of dynamic range, or headroom above the average power output, to pass the loudest portions of the signal without distortion. In other words, music typically has a crest factor between 12 dB and 15 dB. When determining the optimal ambient operating temperature, the internal dissipated power at the average output power level must be used. The TPA0211 data sheet shows that when the TPA0211 is operating from a 5-V supply into a 4- Ω speaker 4-W peaks are available. Converting watts to dB with [Equation 8](#).

$$P_{\text{db}} = 10\text{Log} \frac{P_W}{P_{\text{ref}}} = 10\text{Log} \frac{4 \text{ W}}{1 \text{ W}} = 6 \text{ dB}$$

Subtracting the headroom restriction to obtain the average listening level without distortion yields :

$$\begin{aligned} 6 \text{ dB} - 15 \text{ dB} &= -9 \text{ dB} (15 - \text{dB crest factor}) \\ 6 \text{ dB} - 12 \text{ dB} &= -6 \text{ dB} (12 - \text{dB crest factor}) \\ 6 \text{ dB} - 9 \text{ dB} &= -3 \text{ dB} (9 - \text{dB crest factor}) \\ 6 \text{ dB} - 6 \text{ dB} &= 0 \text{ dB} (6 - \text{dB crest factor}) \\ 6 \text{ dB} - 3 \text{ dB} &= 3 \text{ dB} (3 - \text{dB crest factor}) \end{aligned} \quad (8)$$

Converting dB back into watts with [Equation 9](#).

$$\begin{aligned} P_W &= 10^{\text{PdB}/10} \times P_{\text{ref}} \\ &= 63 \text{ mW} (18 - \text{dB crest factor}) \\ &= 125 \text{ mW} (15 - \text{dB crest factor}) \\ &= 250 \text{ mW} (9 - \text{dB crest factor}) \\ &= 500 \text{ mW} (6 - \text{dB crest factor}) \\ &= 1000 \text{ mW} (3 - \text{dB crest factor}) \\ &= 2000 \text{ mW} (15 - \text{dB crest factor}) \end{aligned} \quad (9)$$

This is valuable information to consider when attempting to estimate the heat dissipation requirements for the amplifier system. Comparing the absolute worst case, which is 2 W of continuous power output with a 3 dB crest factor, against 12 dB and 15 dB applications drastically affects maximum ambient temperature ratings for the system. [Table 3](#) shows maximum ambient temperatures and TPA0211 internal power dissipation for various output-power levels.

Table 3. TPA0211 Power Rating, 5-V, 4-Ω, Mono

| PEAK OUTPUT POWER (W) | AVERAGE OUTPUT POWER | POWER DISSIPATION (W) | MAXIMUM AMBIENT TEMPERATURE |
|-----------------------|-----------------------------|-----------------------|-----------------------------|
| 4 | 2 W (3-dB crest factor) | 1.7 | -3°C |
| 4 | 1000 mW (6-dB crest factor) | 1.6 | 6°C |
| 4 | 500 mW (9-dB crest factor) | 1.4 | 24°C |
| 4 | 250 mW (12-dB crest factor) | 1.1 | 51°C |
| 4 | 125 mW (15-dB crest factor) | 0.8 | 78°C |
| 4 | 63 mW (18-dB crest factor) | 0.6 | 96°C |

As a result, [Equation 10](#) for calculating P_{Dmax} may be used for an 4-Ω application.

$$P_{Dmax} = \frac{2V_{DD}^2}{\pi^2 R_L} \quad (10)$$

However, in the case of a 4-Ω load, the P_{Dmax} occurs at a point well above the normal operating power level. The amplifier may therefore be operated at a higher ambient temperature than required by the P_{Dmax} formula for a 4-Ω load.

9.4 Device Functional Modes

9.4.1 Shutdown Mode

The TPA0211 amplifier can be put in shutdown mode when asserting shutdown pin to a logic LOW. While in shutdown mode, the device output stage is turned off and the current consumption is very low.

9.4.2 SE/BTL (Stereo/Mono) Operation

The ability of the TPA0211 to easily switch between mono BTL and stereo SE modes is one of its most important cost saving features. This feature eliminates the requirement for an additional headphone amplifier in applications where an internal speaker is driven in BTL mode but an external headphone must be accommodated. When SE/BTL is held high for SE mode, the V_{O-} output goes into a high impedance state while the V_{O+} output operates normally. When SE/BTL is held low, the V_{O-} output operates normally, placing the amplifier in BTL mode.

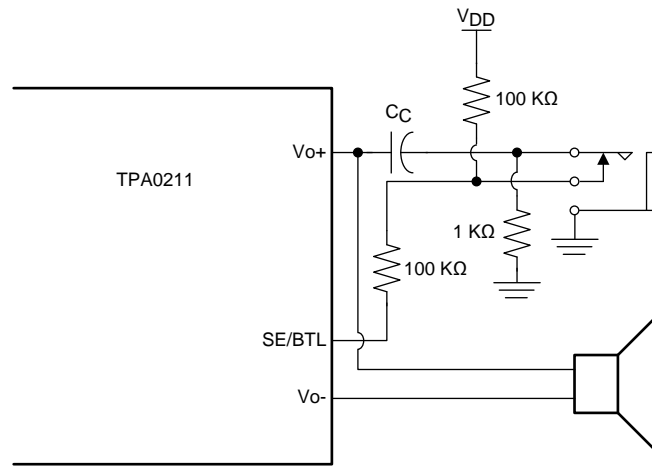
Device Functional Modes (continued)

Copyright © 2016, Texas Instruments Incorporated

Figure 26. TPA0211 Resistor Divider Network Circuit

Using a readily available 1/8-in (3.5 mm) mono headphone jack, the control switch is closed when no plug is inserted. When closed, the 100-kΩ, 1-kΩ divider pulls the SE/BTL input low. When a plug is inserted, the 1-kΩ resistor is disconnected and the SE/BTL input is pulled high.

10 Application and Implementation

NOTE

Information in the following applications sections is not part of the TI component specification, and TI does not warrant its accuracy or completeness. TI's customers are responsible for determining suitability of components for their purposes. Customers should validate and test their design implementation to confirm system functionality.

10.1 Application Information

These typical connection diagrams highlight the required external components and system level connections for proper operation of the device. Each of these configurations can be realized using the Evaluation Modules (EMs) for the device. These flexible modules allow full evaluation of the device in the most common modes of operation. Any design variation can be supported by TI through schematic and layout reviews. Visit e2e.ti.com for design assistance and join the audio amplifier discussion forum for additional information.

10.2 Typical Application

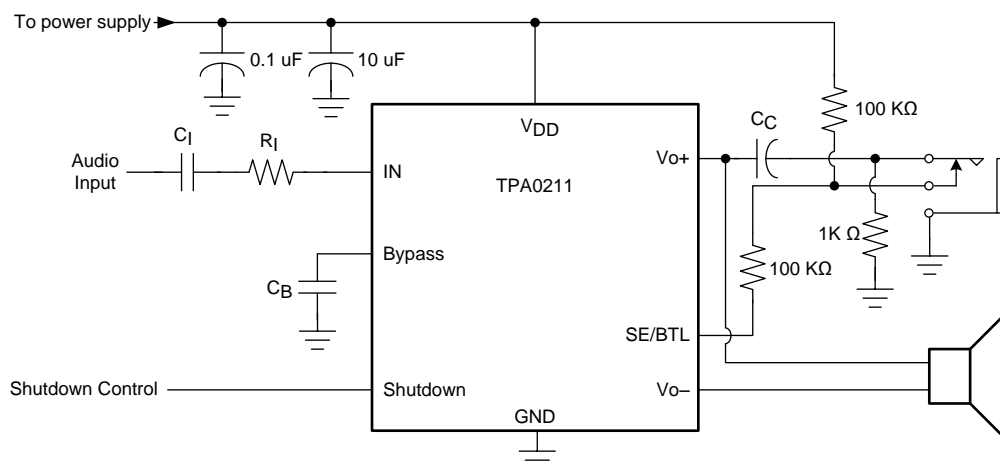

Copyright © 2016, Texas Instruments Incorporated

Figure 27. TPA0211 With SE/BTL Operation

10.2.1 Design Requirements

For this example, [Table 4](#) lists the design parameters.

Table 4. Design Parameters

| PARAMETER | VALUE |
|---------------|-------------|
| Power supply | 5 V |
| Enable inputs | High > 2 V |
| | Low < 0.8 V |
| Speaker | 8 Ω |

10.2.2 Detailed Design Procedure

10.2.2.1 Surface Mount Capacitor

Low-ESR capacitors are recommended throughout this applications section. A real (as opposed to ideal) capacitor can be modeled simply as a resistor in series with an ideal capacitor. The voltage drop across this resistor minimizes the beneficial effects of the capacitor in the circuit. The lower the equivalent value of this resistance the more the real capacitor behaves like an ideal capacitor.

Temperature and applied DC voltage influence the actual capacitance of high-K materials. [Table 5](#) shows the relationship between the different types of high-K materials and their associated tolerances, temperature coefficients, and temperature ranges. Notice that a capacitor made with X5R material can lose up to 15% of its capacitance within its working temperature range.

In an application, the working capacitance of components made with high-K materials is generally much lower than nominal capacitance. A worst case result with a typical X5R material might be –10% tolerance, –15% temperature effect, and –45% DC voltage effect at 50% of the rated voltage. This particular case would result in a working capacitance of 42% ($0.9 \times 0.85 \times 0.55$) of the nominal value.

Select high-K ceramic capacitors according to the following rules:

1. Use capacitors made of materials with temperature coefficients of X5R, X7R, or better.
2. Use capacitors with DC voltage ratings of at least twice the application voltage. Use minimum 10-V capacitors for this device.
3. Choose a capacitance value at least twice the nominal value calculated for the application. Multiply the nominal value by a factor of 2 for safety. If a 10- μ F capacitor is required, use 20 μ F.

The preceding rules and recommendations apply to capacitors used in connection with the device. This device cannot meet its performance specifications if the rules and recommendations are not followed.

Table 5. Typical Tolerance and Temperature Coefficient of Capacitance by Material

| MATERIAL | TYPICAL TOLERANCE | TEMPERATURE | TEMPERATURE RANGE (°C) |
|----------|-------------------|-------------|------------------------|
| COG/NOP | ±5% | ±30 ppm | –55 to 125 |
| X7R | ±10% | ±15% | –55 to 125 |
| X5R | 80% to –20% | 22% to –82% | –30 to 85 |

10.2.2.2 Input Capacitor, C_i

In the typical application an input capacitor, C_i , is required to allow the amplifier to bias the input signal to the proper dc level for optimum operation. In this case, C_i and the input resistance of the amplifier, R_i , form a high-pass filter with the corner frequency determined in [Equation 11](#).

$$f_{c(\text{highpass})} = \frac{1}{2\pi R_i C_i}$$

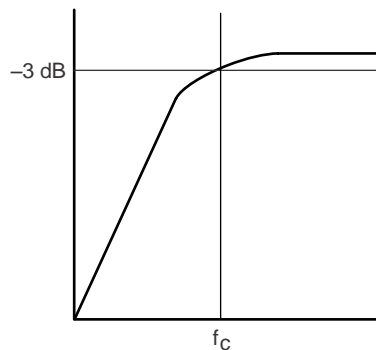

(11)

The value of C_i is important to consider as it directly affects the bass (low frequency) performance of the circuit. Consider the example where R_i is 10 k Ω and the specification calls for a flat bass response down to 40 Hz. [Equation 6](#) is reconfigured as [Equation 12](#).

$$C_i = \frac{1}{2\pi R_i f_c}$$

(12)

In this example, C_i is 0.4 μ F so one would likely choose a value in the range of 0.47 μ F to 1 μ F. A further consideration for this capacitor is the leakage path from the input source through the input network (C_i) and the feedback network to the load. This leakage current creates a dc offset voltage at the input to the amplifier that reduces useful headroom, especially in high gain applications. For this reason a low-leakage tantalum or ceramic capacitor is the best choice. When polarized capacitors are used, the positive side of the capacitor should face the amplifier input in most applications as the dc level there is held at $V_{DD}/2$, which is likely higher than the source dc level. Note that it is important to confirm the capacitor polarity in the application.

10.2.2.3 Power Supply Decoupling, $C_{(S)}$

The TPA0211 is a high-performance CMOS audio amplifier that requires adequate power supply decoupling to ensure the output total harmonic distortion (THD) is as low as possible. Power supply decoupling also prevents oscillations for long lead lengths between the amplifier and the speaker. The optimum decoupling is achieved by using two capacitors of different types that target different types of noise on the power supply leads. For higher frequency transients, spikes, or digital hash on the line, a good low equivalent-series-resistance (ESR) ceramic capacitor, typically 0.1 μF placed as close as possible to the device V_{DD} lead, works best. For filtering lower-frequency noise signals, TI recommends a larger aluminum electrolytic capacitor of 10 μF or greater placed near the audio power amplifier.

10.2.2.4 Midrail Bypass Capacitor, $C_{(BYP)}$

The midrail bypass capacitor, $C_{(BYP)}$, is the most critical capacitor and serves several important functions. During start-up or recovery from shutdown mode, $C_{(BYP)}$ determines the rate at which the amplifier starts up. The second function is to reduce noise produced by the power supply caused by coupling into the output drive signal. This noise is from the midrail generation circuit internal to the amplifier, which appears as degraded PSRR and THD+N.

Bypass capacitor, $C_{(BYP)}$, values of 0.47 μF to 1 μF ceramic or tantalum low-ESR capacitors are recommended for the best THD and noise performance.

10.2.2.5 Output Coupling Capacitor, $C_{(C)}$

In the typical single-supply SE configuration, an output coupling capacitor ($C_{(C)}$) is required to block the dc bias at the output of the amplifier thus preventing dc currents in the load. As with the input coupling capacitor, the output coupling capacitor and impedance of the load form a high-pass filter governed by Equation 13.

$$f_{c(\text{high})} = \frac{1}{2\pi R_L C_{(C)}}$$

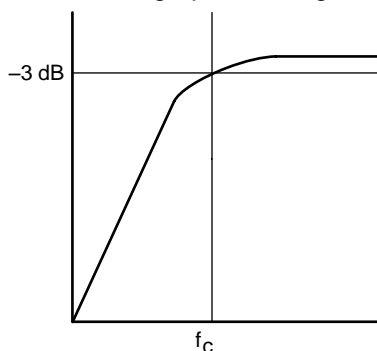

(13)

The main disadvantage, from a performance standpoint, is that the load impedances are typically small, which drives the low-frequency corner higher, degrading the bass response. Large values of $C_{(C)}$ are required to pass low frequencies into the load. Consider the example where a $C_{(C)}$ of 330 μF is chosen and loads vary from 3 Ω , 4 Ω , 8 Ω , 32 Ω , 10 k Ω , to 47 k Ω . Table 6 summarizes the frequency response characteristics of each configuration.

Table 6. Common Load Impedances vs Low Frequency Output Characteristics in SE Mode

| R_L | $C_{(C)}$ | LOWEST FREQUENCY |
|-----------------|-------------------|------------------|
| 3 Ω | 330 μF | 161 Hz |
| 4 Ω | 330 μF | 120 Hz |
| 8 Ω | 330 μF | 60 Hz |
| 32 Ω | 330 μF | 15 Hz |
| 10,000 Ω | 330 μF | 0.05 Hz |
| 47,000 Ω | 330 μF | 0.01 Hz |

As [Table 6](#) indicates, most of the bass response is attenuated into a 4-Ω load, an 8-Ω load is adequate, headphone response is good, and drive into line level inputs (a home stereo for example) is exceptional.

Furthermore, the total amount of ripple current that must flow through the capacitor must be considered when choosing the component. As shown in the application circuit, one coupling capacitor must be in series with the mono loudspeaker for proper operation of the stereo-mono switching circuit. For a 4-Ω load, this capacitor must be able to handle about 700 mA of ripple current for a continuous output power of 2 W.

10.2.3 Application Curves

[Table 7](#) lists the figures for the application curves.

Table 7. Table of Graphs

| DESCRIPTION | FIGURE ⁽¹⁾ |
|----------------------------------|---------------------------|
| Supply current vs Supply voltage | Figure 3 |
| Output power vs Load resistance | Figure 6 |
| THD+N vs Frequency | Figure 8 |
| THD+N vs Output power | Figure 12 |

(1) All figures are located in [Typical Characteristics](#).

11 Power Supply Recommendations

The TPA0211 is designed to operate from an input voltage supply range from 2.5 V to 5.5 V. Therefore, the output voltage range of the power supply must be within this range. The current capability of upper power must not exceed the maximum current limit of the power switch.

11.1 Power Supply Decoupling Capacitors

The TPA0211 requires adequate power supply decoupling to ensure a high efficiency operation with low total harmonic distortion (THD). Place a low equivalent-series-resistance (ESR) ceramic capacitor, typically 0.1 μF , within 2 mm of the VDD pin. This choice of capacitor and placement helps with higher frequency transients, spikes, or digital hash on the line. In addition to the 0.1- μF ceramic capacitor, is recommended to place a 2.2- μF to 10- μF capacitor on the VDD supply trace. This larger capacitor acts as a charge reservoir, providing energy faster than the board supply, thus helping to prevent any droop in the supply voltage.

12 Layout

12.1 Layout Guidelines

12.1.1 Component Placement

Keeping the external components very close to the TPA0211 to limit noise pickup is very important to limit noise pickup. Placing the decoupling capacitors as close as possible to the device is important for the performance of the class-AB amplifier.

12.2 Layout Example

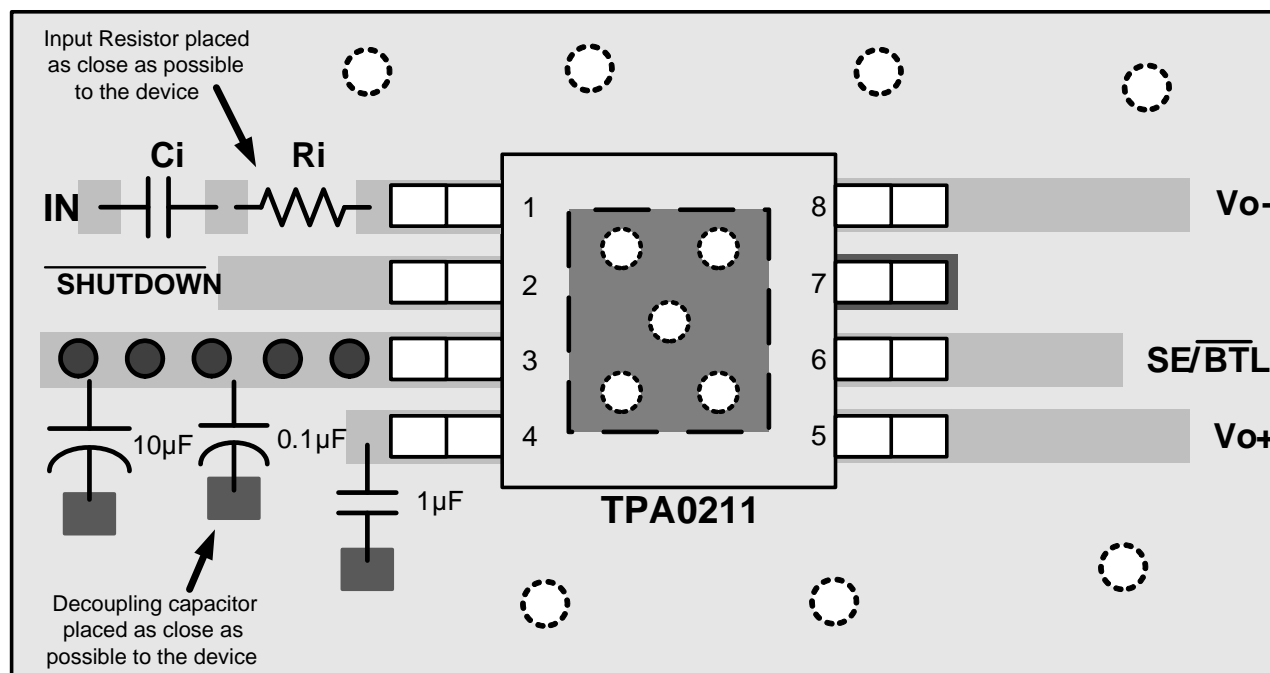

Copyright © 2016, Texas Instruments Incorporated

Figure 28. Layout Recommendation

12.3 Thermal Considerations

The maximum ambient temperature depends on the heat sinking ability of the PCB system. The derating factor for the DGN package is shown in the [Dissipation Ratings](#). Converting this θ_{JA} can be done with [Equation 14](#).

$$\Theta_{JA} = \frac{1}{\text{Derating Factor}} = \frac{1}{0.0171} = 58.48^{\circ}\text{C} / \text{W} \quad (14)$$

To calculate maximum ambient temperatures, first consider that the numbers from the dissipation graphs are per channel so the dissipated power needs to be doubled for two channel operation. Given $R_{\theta JA}$, the maximum allowable junction temperature, and the total internal dissipation, the maximum ambient temperature can be calculated with [Equation 15](#). The maximum recommended junction temperature for the TPA0211 is 150°C.

$$T_{A\text{Max}} = T_{J\text{Max}} - \Theta_{JA} P_D = 150 - 58.48(0.8 \times 2) = 56^{\circ}\text{C} (15 - \text{dB crest factor}) \quad (15)$$

NOTE

Internal dissipation of 0.8 W is estimated for a 2-W system with 15-dB crest factor per channel.

[Table 3](#) shows that for some applications no airflow is required to keep junction temperatures in the specified range. The TPA0211 is designed with thermal protection that turns the device off when the junction temperature surpasses 150°C to prevent damage to the IC. [Table 3](#) was calculated for maximum listening volume without distortion. When the output level is reduced the numbers in the table change significantly. Also, using 8-Ω speakers dramatically increases the thermal performance by increasing amplifier efficiency.

13 Device and Documentation Support

13.1 Documentation Support

13.1.1 Related Documentation

For related documentation see the following:

- [PowerPAD™ Thermally Enhanced Package](#) (SLMA002)
- [Guidelines for Measuring Audio Power Amplifier Performance](#) (SLOA068)
- [TPA0211EVM - User Guide](#) (SLOU092)

13.2 Receiving Notification of Documentation Updates

To receive notification of documentation updates, navigate to the device product folder on ti.com. In the upper right corner, click on *Alert me* to register and receive a weekly digest of any product information that has changed. For change details, review the revision history included in any revised document.

13.3 Community Resources

The following links connect to TI community resources. Linked contents are provided "AS IS" by the respective contributors. They do not constitute TI specifications and do not necessarily reflect TI's views; see TI's [Terms of Use](#).

TI E2E™ Online Community *TI's Engineer-to-Engineer (E2E) Community*. Created to foster collaboration among engineers. At e2e.ti.com, you can ask questions, share knowledge, explore ideas and help solve problems with fellow engineers.

Design Support *TI's Design Support* Quickly find helpful E2E forums along with design support tools and contact information for technical support.

13.4 Trademarks

PowerPAD, E2E are trademarks of Texas Instruments.
All other trademarks are the property of their respective owners.

13.5 Electrostatic Discharge Caution



These devices have limited built-in ESD protection. The leads should be shorted together or the device placed in conductive foam during storage or handling to prevent electrostatic damage to the MOS gates.

13.6 Glossary

[SLYZ022](#) — *TI Glossary*.

This glossary lists and explains terms, acronyms, and definitions.

14 Mechanical, Packaging, and Orderable Information

The following pages include mechanical, packaging, and orderable information. This information is the most current data available for the designated devices. This data is subject to change without notice and revision of this document. For browser-based versions of this data sheet, refer to the left-hand navigation.

PACKAGING INFORMATION

| Orderable Device | Status (1) | Package Type | Package Drawing | Pins | Package Qty | Eco Plan (2) | Lead/Ball Finish (6) | MSL Peak Temp (3) | Op Temp (°C) | Device Marking (4/5) | Samples |
|------------------|---------------|---------------|-----------------|------|-------------|-------------------------|-------------------------|----------------------|--------------|-------------------------|-------------------------|
| TPA0211DGN | ACTIVE | MSOP-PowerPAD | DGN | 8 | 80 | Green (RoHS & no Sb/Br) | CU NIPDAU CU NIPDAUAG | Level-1-260C-UNLIM | -40 to 85 | AEG | Samples |
| TPA0211DGNG4 | ACTIVE | MSOP-PowerPAD | DGN | 8 | 80 | Green (RoHS & no Sb/Br) | CU NIPDAUAG | Level-1-260C-UNLIM | -40 to 85 | AEG | Samples |
| TPA0211DGNR | ACTIVE | MSOP-PowerPAD | DGN | 8 | 2500 | Green (RoHS & no Sb/Br) | CU NIPDAU CU NIPDAUAG | Level-1-260C-UNLIM | -40 to 85 | AEG | Samples |

(1) The marketing status values are defined as follows:

ACTIVE: Product device recommended for new designs.

LIFEBUY: TI has announced that the device will be discontinued, and a lifetime-buy period is in effect.

NRND: Not recommended for new designs. Device is in production to support existing customers, but TI does not recommend using this part in a new design.

PREVIEW: Device has been announced but is not in production. Samples may or may not be available.

OBsolete: TI has discontinued the production of the device.

(2) **RoHS:** TI defines "RoHS" to mean semiconductor products that are compliant with the current EU RoHS requirements for all 10 RoHS substances, including the requirement that RoHS substance do not exceed 0.1% by weight in homogeneous materials. Where designed to be soldered at high temperatures, "RoHS" products are suitable for use in specified lead-free processes. TI may reference these types of products as "Pb-Free".

RoHS Exempt: TI defines "RoHS Exempt" to mean products that contain lead but are compliant with EU RoHS pursuant to a specific EU RoHS exemption.

Green: TI defines "Green" to mean the content of Chlorine (Cl) and Bromine (Br) based flame retardants meet JS709B low halogen requirements of <=1000ppm threshold. Antimony trioxide based flame retardants must also meet the <=1000ppm threshold requirement.

(3) MSL, Peak Temp. - The Moisture Sensitivity Level rating according to the JEDEC industry standard classifications, and peak solder temperature.

(4) There may be additional marking, which relates to the logo, the lot trace code information, or the environmental category on the device.

(5) Multiple Device Markings will be inside parentheses. Only one Device Marking contained in parentheses and separated by a "-" will appear on a device. If a line is indented then it is a continuation of the previous line and the two combined represent the entire Device Marking for that device.

(6) Lead/Ball Finish - Orderable Devices may have multiple material finish options. Finish options are separated by a vertical ruled line. Lead/Ball Finish values may wrap to two lines if the finish value exceeds the maximum column width.

Important Information and Disclaimer:The information provided on this page represents TI's knowledge and belief as of the date that it is provided. TI bases its knowledge and belief on information provided by third parties, and makes no representation or warranty as to the accuracy of such information. Efforts are underway to better integrate information from third parties. TI has taken and continues to take reasonable steps to provide representative and accurate information but may not have conducted destructive testing or chemical analysis on incoming materials and chemicals. TI and TI suppliers consider certain information to be proprietary, and thus CAS numbers and other limited information may not be available for release.

In no event shall TI's liability arising out of such information exceed the total purchase price of the TI part(s) at issue in this document sold by TI to Customer on an annual basis.

TAPE AND REEL INFORMATION



QUADRANT ASSIGNMENTS FOR PIN 1 ORIENTATION IN TAPE



*All dimensions are nominal

| Device | Package Type | Package Drawing | Pins | SPQ | Reel Diameter (mm) | Reel Width W1 (mm) | A0 (mm) | B0 (mm) | K0 (mm) | P1 (mm) | W (mm) | Pin1 Quadrant |
|-------------|----------------|-----------------|------|------|--------------------|--------------------|---------|---------|---------|---------|--------|---------------|
| TPA0211DGNR | MSOP-Power PAD | DGN | 8 | 2500 | 330.0 | 12.4 | 5.3 | 3.4 | 1.4 | 8.0 | 12.0 | Q1 |
| TPA0211DGNR | MSOP-Power PAD | DGN | 8 | 2500 | 330.0 | 12.4 | 5.3 | 3.4 | 1.4 | 8.0 | 12.0 | Q1 |

TAPE AND REEL BOX DIMENSIONS

*All dimensions are nominal

| Device | Package Type | Package Drawing | Pins | SPQ | Length (mm) | Width (mm) | Height (mm) |
|-------------|---------------|-----------------|------|------|-------------|------------|-------------|
| TPA0211DGNR | MSOP-PowerPAD | DGN | 8 | 2500 | 364.0 | 364.0 | 27.0 |
| TPA0211DGNR | MSOP-PowerPAD | DGN | 8 | 2500 | 358.0 | 335.0 | 35.0 |

DGN (S-PDSO-G8)

PowerPAD™ PLASTIC SMALL OUTLINE

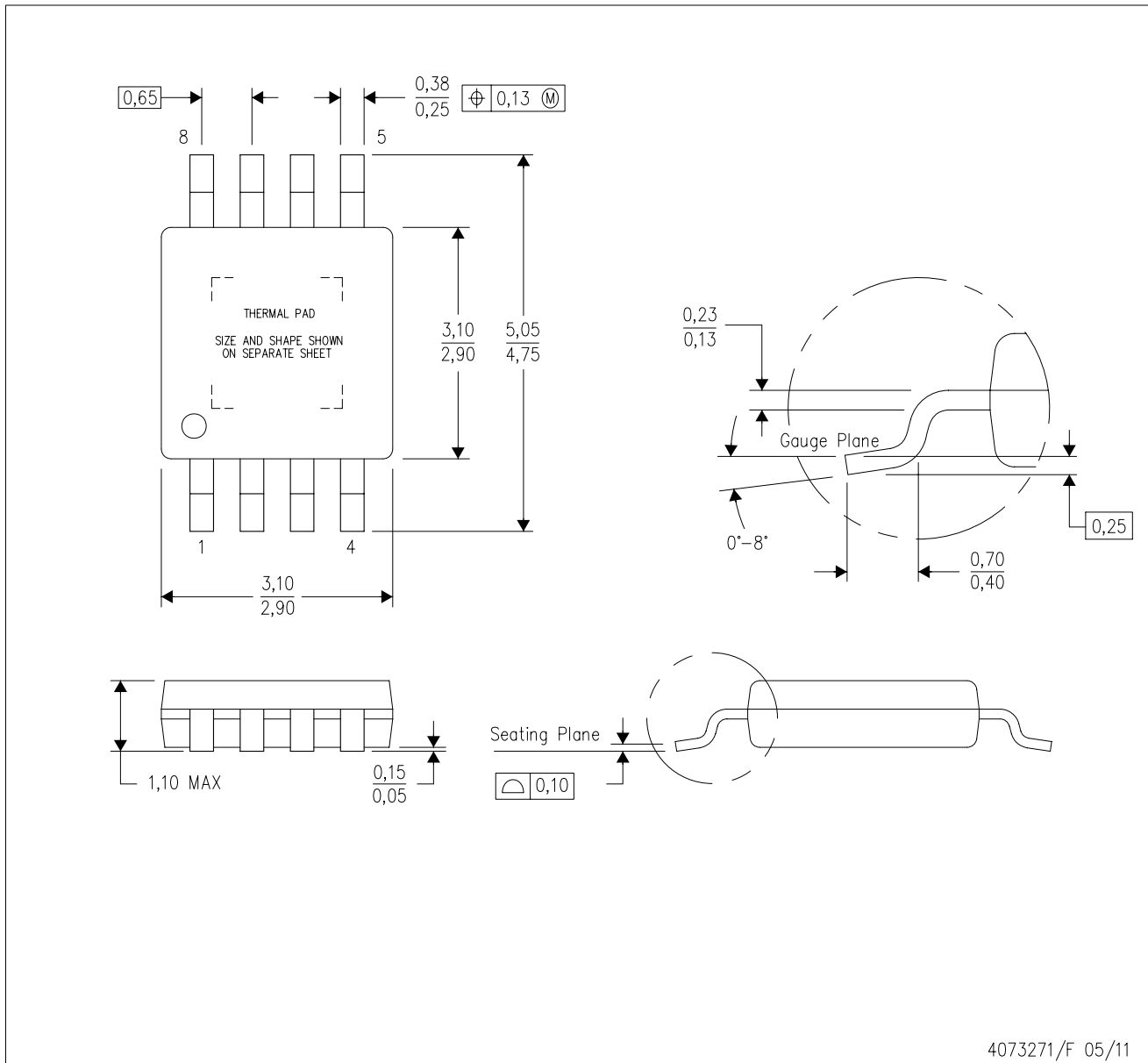

- NOTES:
- A. All linear dimensions are in millimeters.
 - B. This drawing is subject to change without notice.
 - C. Body dimensions do not include mold flash or protrusion.
 - D. This package is designed to be soldered to a thermal pad on the board. Refer to Technical Brief, PowerPad Thermally Enhanced Package, Texas Instruments Literature No. SLMA002 for information regarding recommended board layout. This document is available at www.ti.com <<http://www.ti.com>>.
 - E. See the additional figure in the Product Data Sheet for details regarding the exposed thermal pad features and dimensions.
 - F. Falls within JEDEC MO-187 variation AA-T

PowerPAD is a trademark of Texas Instruments.

DGN (S-PDSO-G8)

PowerPAD™ PLASTIC SMALL OUTLINE

THERMAL INFORMATION

This PowerPAD™ package incorporates an exposed thermal pad that is designed to be attached to a printed circuit board (PCB). The thermal pad must be soldered directly to the PCB. After soldering, the PCB can be used as a heatsink. In addition, through the use of thermal vias, the thermal pad can be attached directly to the appropriate copper plane shown in the electrical schematic for the device, or alternatively, can be attached to a special heatsink structure designed into the PCB. This design optimizes the heat transfer from the integrated circuit (IC).

For additional information on the PowerPAD package and how to take advantage of its heat dissipating abilities, refer to Technical Brief, PowerPAD Thermally Enhanced Package, Texas Instruments Literature No. SLMA002 and Application Brief, PowerPAD Made Easy, Texas Instruments Literature No. SLMA004. Both documents are available at www.ti.com.

The exposed thermal pad dimensions for this package are shown in the following illustration.

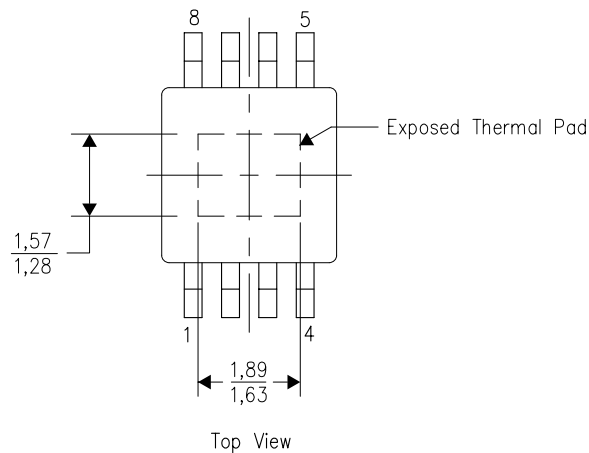

Exposed Thermal Pad Dimensions

4206323-2/1 12/11

NOTE: All linear dimensions are in millimeters

PowerPAD is a trademark of Texas Instruments

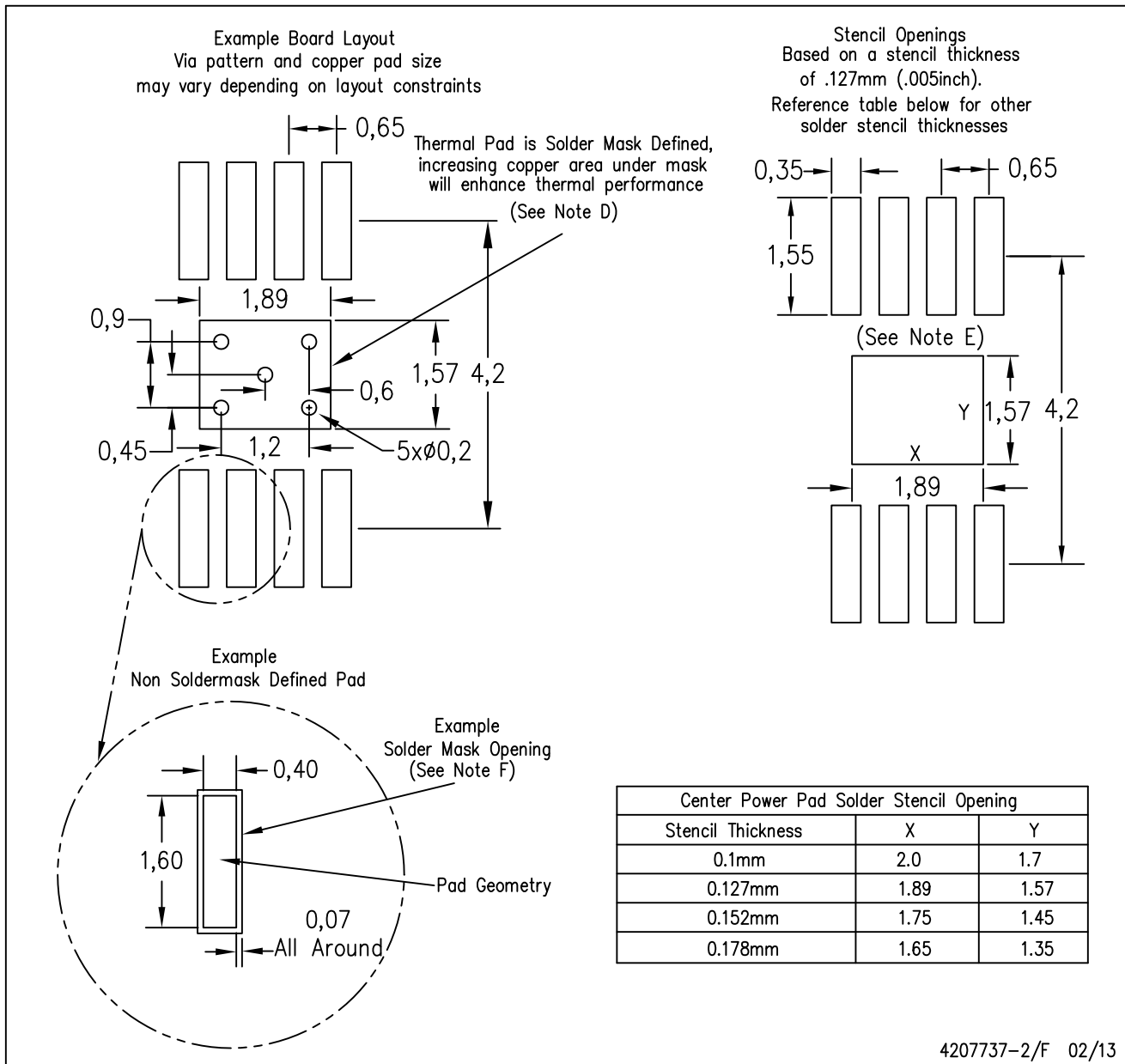

- NOTES:
- A. All linear dimensions are in millimeters.
 - B. This drawing is subject to change without notice.
 - C. Customers should place a note on the circuit board fabrication drawing not to alter the center solder mask defined pad.
 - D. This package is designed to be soldered to a thermal pad on the board. Refer to Technical Brief, PowerPad Thermally Enhanced Package, Texas Instruments Literature No. SLMA002, SLMA004, and also the Product Data Sheets for specific thermal information, via requirements, and recommended board layout. These documents are available at www.ti.com <<http://www.ti.com>>.
 - E. Laser cutting apertures with trapezoidal walls and also rounding corners will offer better paste release. Customers should contact their board assembly site for stencil design recommendations. Example stencil design based on a 50% volumetric metal load solder paste. Refer to IPC-7525 for other stencil recommendations.
 - F. Customers should contact their board fabrication site for solder mask tolerances between and around signal pads.

PowerPAD is a trademark of Texas Instruments

IMPORTANT NOTICE

Texas Instruments Incorporated (TI) reserves the right to make corrections, enhancements, improvements and other changes to its semiconductor products and services per JESD46, latest issue, and to discontinue any product or service per JESD48, latest issue. Buyers should obtain the latest relevant information before placing orders and should verify that such information is current and complete.

TI's published terms of sale for semiconductor products (<http://www.ti.com/sc/docs/stdterms.htm>) apply to the sale of packaged integrated circuit products that TI has qualified and released to market. Additional terms may apply to the use or sale of other types of TI products and services.

Reproduction of significant portions of TI information in TI data sheets is permissible only if reproduction is without alteration and is accompanied by all associated warranties, conditions, limitations, and notices. TI is not responsible or liable for such reproduced documentation. Information of third parties may be subject to additional restrictions. Resale of TI products or services with statements different from or beyond the parameters stated by TI for that product or service voids all express and any implied warranties for the associated TI product or service and is an unfair and deceptive business practice. TI is not responsible or liable for any such statements.

Buyers and others who are developing systems that incorporate TI products (collectively, "Designers") understand and agree that Designers remain responsible for using their independent analysis, evaluation and judgment in designing their applications and that Designers have full and exclusive responsibility to assure the safety of Designers' applications and compliance of their applications (and of all TI products used in or for Designers' applications) with all applicable regulations, laws and other applicable requirements. Designer represents that, with respect to their applications, Designer has all the necessary expertise to create and implement safeguards that (1) anticipate dangerous consequences of failures, (2) monitor failures and their consequences, and (3) lessen the likelihood of failures that might cause harm and take appropriate actions. Designer agrees that prior to using or distributing any applications that include TI products, Designer will thoroughly test such applications and the functionality of such TI products as used in such applications.

TI's provision of technical, application or other design advice, quality characterization, reliability data or other services or information, including, but not limited to, reference designs and materials relating to evaluation modules, (collectively, "TI Resources") are intended to assist designers who are developing applications that incorporate TI products; by downloading, accessing or using TI Resources in any way, Designer (individually or, if Designer is acting on behalf of a company, Designer's company) agrees to use any particular TI Resource solely for this purpose and subject to the terms of this Notice.

TI's provision of TI Resources does not expand or otherwise alter TI's applicable published warranties or warranty disclaimers for TI products, and no additional obligations or liabilities arise from TI providing such TI Resources. TI reserves the right to make corrections, enhancements, improvements and other changes to its TI Resources. TI has not conducted any testing other than that specifically described in the published documentation for a particular TI Resource.

Designer is authorized to use, copy and modify any individual TI Resource only in connection with the development of applications that include the TI product(s) identified in such TI Resource. NO OTHER LICENSE, EXPRESS OR IMPLIED, BY ESTOPPEL OR OTHERWISE TO ANY OTHER TI INTELLECTUAL PROPERTY RIGHT, AND NO LICENSE TO ANY TECHNOLOGY OR INTELLECTUAL PROPERTY RIGHT OF TI OR ANY THIRD PARTY IS GRANTED HEREIN, including but not limited to any patent right, copyright, mask work right, or other intellectual property right relating to any combination, machine, or process in which TI products or services are used. Information regarding or referencing third-party products or services does not constitute a license to use such products or services, or a warranty or endorsement thereof. Use of TI Resources may require a license from a third party under the patents or other intellectual property of the third party, or a license from TI under the patents or other intellectual property of TI.

TI RESOURCES ARE PROVIDED "AS IS" AND WITH ALL FAULTS. TI DISCLAIMS ALL OTHER WARRANTIES OR REPRESENTATIONS, EXPRESS OR IMPLIED, REGARDING RESOURCES OR USE THEREOF, INCLUDING BUT NOT LIMITED TO ACCURACY OR COMPLETENESS, TITLE, ANY EPIDEMIC FAILURE WARRANTY AND ANY IMPLIED WARRANTIES OF MERCHANTABILITY, FITNESS FOR A PARTICULAR PURPOSE, AND NON-INFRINGEMENT OF ANY THIRD PARTY INTELLECTUAL PROPERTY RIGHTS. TI SHALL NOT BE LIABLE FOR AND SHALL NOT DEFEND OR INDEMNIFY DESIGNER AGAINST ANY CLAIM, INCLUDING BUT NOT LIMITED TO ANY INFRINGEMENT CLAIM THAT RELATES TO OR IS BASED ON ANY COMBINATION OF PRODUCTS EVEN IF DESCRIBED IN TI RESOURCES OR OTHERWISE. IN NO EVENT SHALL TI BE LIABLE FOR ANY ACTUAL, DIRECT, SPECIAL, COLLATERAL, INDIRECT, PUNITIVE, INCIDENTAL, CONSEQUENTIAL OR EXEMPLARY DAMAGES IN CONNECTION WITH OR ARISING OUT OF TI RESOURCES OR USE THEREOF, AND REGARDLESS OF WHETHER TI HAS BEEN ADVISED OF THE POSSIBILITY OF SUCH DAMAGES.

Unless TI has explicitly designated an individual product as meeting the requirements of a particular industry standard (e.g., ISO/TS 16949 and ISO 26262), TI is not responsible for any failure to meet such industry standard requirements.

Where TI specifically promotes products as facilitating functional safety or as compliant with industry functional safety standards, such products are intended to help enable customers to design and create their own applications that meet applicable functional safety standards and requirements. Using products in an application does not by itself establish any safety features in the application. Designers must ensure compliance with safety-related requirements and standards applicable to their applications. Designer may not use any TI products in life-critical medical equipment unless authorized officers of the parties have executed a special contract specifically governing such use. Life-critical medical equipment is medical equipment where failure of such equipment would cause serious bodily injury or death (e.g., life support, pacemakers, defibrillators, heart pumps, neurostimulators, and implantables). Such equipment includes, without limitation, all medical devices identified by the U.S. Food and Drug Administration as Class III devices and equivalent classifications outside the U.S.

TI may expressly designate certain products as completing a particular qualification (e.g., Q100, Military Grade, or Enhanced Product). Designers agree that it has the necessary expertise to select the product with the appropriate qualification designation for their applications and that proper product selection is at Designers' own risk. Designers are solely responsible for compliance with all legal and regulatory requirements in connection with such selection.

Designer will fully indemnify TI and its representatives against any damages, costs, losses, and/or liabilities arising out of Designer's non-compliance with the terms and provisions of this Notice.

Looking for pricing, stock, or lifecycle information?

Click below to explore more details on WIN SOURCE:

 [View TPA0211DGN](#) on WIN SOURCE

 [Texas Instruments](#) Information

Optimize Your Supply Chain with WIN SOURCE Solutions

-  Global Sourcing Solution
-  Obsolete Management
-  Cost Control Management
-  Shortage Management
-  Alternative Solution
-  Excess Inventory Management