



# THE DATASHEET OF TMP112AIDRLR



# TMP112x High-Accuracy, Low-Power, Digital Temperature Sensors With SMBus and Two-Wire Serial Interface in SOT563 and X2SON Packages

## 1 Features

- TMP112A Accuracy Without Calibration:
  - $\pm 0.5^{\circ}\text{C}$  (Maximum) From  $0^{\circ}\text{C}$  to  $+65^{\circ}\text{C}$  (3.3V)
  - $\pm 1.0^{\circ}\text{C}$  (Maximum) From  $-40^{\circ}\text{C}$  to  $+125^{\circ}\text{C}$
- TMP112B Accuracy Without Calibration:
  - $\pm 0.5^{\circ}\text{C}$  (Maximum) From  $0^{\circ}\text{C}$  to  $+65^{\circ}\text{C}$  (1.8V)
  - $\pm 1.0^{\circ}\text{C}$  (Maximum) From  $-40^{\circ}\text{C}$  to  $+125^{\circ}\text{C}$
- TMP112N Accuracy Without Calibration:
  - $\pm 1.0^{\circ}\text{C}$  (Maximum) From  $-40^{\circ}\text{C}$  to  $+125^{\circ}\text{C}$
- TMP112Dx Accuracy Without Calibration:
  - $\pm 0.5^{\circ}\text{C}$  (Maximum) From  $-25^{\circ}\text{C}$  to  $85^{\circ}\text{C}$  ( $V+ \geq 1.5\text{V}$ )
  - $\pm 1.0^{\circ}\text{C}$  (Maximum) From  $-40^{\circ}\text{C}$  to  $125^{\circ}\text{C}$
- SOT563 Package (1.6mm  $\times$  1.6mm)
- X2SON Package (0.8mm  $\times$  0.8mm)
- Low Quiescent Current:
  - 10- $\mu\text{A}$  Active (Maximum), 1- $\mu\text{A}$  Shutdown (Maximum)
- Supply Range: 1.4V to 3.6V
- Resolution: 12 Bits
- Digital Output: SMBus™, Two-Wire, and I<sup>2</sup>C Interface Compatibility
- NIST Traceable

## 2 Applications

- **Building automation**
  - Occupancy detection
  - Video doorbell
  - HVAC: Wireless environmental sensor
- **Factory automation & control**
  - Machine vision camera
  - Industrial PC: Single board computer
  - CPU (PLC controller)
- Cold chain
- **Data center & enterprise computing**
  - Solid state drive (SSD)
  - Rack Server Motherboard
- **Personal electronics**
  - PC & notebooks, tablets
  - Digital still & video camera
  - Augmented reality glasses
  - Smart speakers

## 3 Description

The TMP112 family of devices are digital temperature sensors designed for high-accuracy, low-power, NTC/PTC thermistor replacements where high accuracy is required. The TMP112A, TMP112B,

TMP112Dx offer  $0.5^{\circ}\text{C}$  accuracy and are optimized to provide the best PSR performance for 3.3V, 1.8V and  $\geq 1.5\text{V}$  operation respectively, while TMP112N offers  $1^{\circ}\text{C}$  accuracy. These temperature sensors are highly linear and do not require complex calculations or lookup tables to derive the temperature. The on-chip 12-bit ADC offers resolutions down to  $0.0625^{\circ}\text{C}$ .

The 1.6mm  $\times$  1.6mm SOT563 package is 68% smaller footprint than an SOT23 package while TMP112Dx utilizes ultra-small ( $0.64\text{mm}^2$ ) 5-pin package. The TMP112 family features SMBus, two-wire and I<sup>2</sup>C interface compatibility, and allows up to four devices on one bus. The device also features an SMBus alert function or variant. The device is specified to operate over supply voltages from 1.4V to 3.6V with the typical quiescent current 3.2 $\mu\text{A}$  over the full operating range.

The TMP112 family is designed for extended temperature measurement in communication, computer, consumer, environmental, industrial, and instrumentation applications. The device is specified for operation over a temperature range of  $-40^{\circ}\text{C}$  to  $125^{\circ}\text{C}$ .

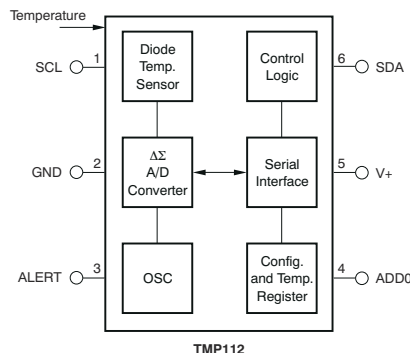
The TMP112 family production units are 100% tested against sensors that are NIST-traceable and are verified with equipment that are NIST-traceable through ISO/IEC 17025 accredited calibrations.

### Package Information

PART NUMBER	PACKAGE <sup>(1)</sup>	PACKAGE SIZE <sup>(2)</sup>
TMP112A/B/N	SOT563 (6)	1.6mm $\times$ 1.6mm
TMP112Dx	X2SON (5)	0.8mm $\times$ 0.8mm

(1) For more information, see [Section 11](#).

(2) The package size (length  $\times$  width) is a nominal value and includes pins, where applicable.



**Block Diagram (SOT563 Package)**



## Table of Contents

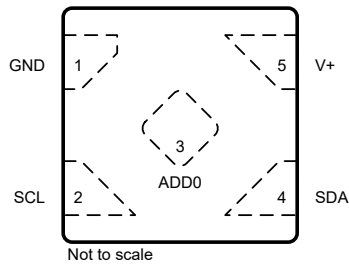
<b>1 Features</b> .....	1	7.3 Feature Description.....	15
<b>2 Applications</b> .....	1	7.4 Device Functional Modes.....	22
<b>3 Description</b> .....	1	7.5 Programming .....	23
<b>4 Device Comparison</b> .....	3	<b>8 Application and Implementation</b> .....	28
<b>5 Pin Configuration and Functions</b> .....	4	8.1 Application Information.....	28
<b>6 Specifications</b> .....	5	8.2 Typical Application .....	28
6.1 Absolute Maximum Ratings.....	5	8.3 Layout.....	30
6.2 Handling Ratings.....	5	<b>9 Device and Documentation Support</b> .....	34
6.3 Recommended Operating Conditions.....	5	9.1 Documentation Support .....	34
6.4 Thermal Information.....	5	9.2 Receiving Notification of Documentation Updates....	34
6.5 Electrical Characteristics.....	6	9.3 Support Resources.....	34
6.6 Timing Requirements.....	8	9.4 Trademarks.....	34
6.7 Timing Diagrams .....	8	9.5 Electrostatic Discharge Caution.....	34
6.8 Typical Characteristics (TMP112A/B/N).....	9	9.6 Glossary.....	34
6.9 Typical Characteristics (TMP112Dx).....	10	<b>10 Revision History</b> .....	35
<b>7 Detailed Description</b> .....	14	<b>11 Mechanical, Packaging, and Orderable Information</b> .....	35
7.1 Overview.....	14		
7.2 Functional Block Diagrams.....	14		

## 4 Device Comparison

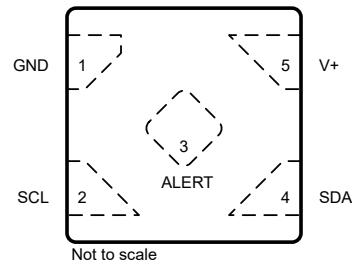
**Table 4-1. Device Options**

Feature	TMP102	TMP110	TMP112A	TMP112B	TMP112N	TMP112Dx	TMP1075N
VDD Range (V)	1.4 - 3.6	1.14 - 5.5	1.4 - 3.6	1.4 - 3.6	1.4 - 3.6	1.4 - 3.6	1.62 - 3.6
I <sub>AVG</sub> (μA) (Typ)	7 @ 4Hz	3.2 @ 1Hz	3.2 @ 1Hz 7 @ 4Hz	3.2 @ 1Hz 7 @ 4Hz	3.2 @ 1Hz 7 @ 4Hz	3.2 @ 1Hz 4.8 @ 4Hz	7 @ 4Hz
I <sub>Q_ACTIVE</sub> (μA) (Typ)	40	55	40	40	40	55	-
I <sub>SB</sub> (μA)	2.2	2.6	2.2	2.2	2.2	2.6	-
I <sub>SD</sub> (μA)	0.5	0.15	0.5	0.5	0.5	0.15	0.5
Conversion Time (ms)	26	10	26	26	26	10	26
<b>Accuracy</b>							
0°C to 65°C (max)	-	-	±0.5 @ 3.3V	±0.5 @ 1.8V	-	-	-
-10°C to 65°C (max)	-	-	-	-	-	-	±1
-25°C to 85°C (max)	±2	-	-	-	-	±0.5 @ ≥1.5V	-
-40°C to 125°C (max)	±3	±1	±1	±1	±1	±1	±2
<b>Packaging</b>							
Dimensions [mm × mm × mm]	SOT563-6 [1.6 × 1.6 × 0.6]	X2SON-5 [0.8 × 0.8 × 0.4]	SOT563-6 [1.6 × 1.6 × 0.6]			X2SON-5 [0.8 × 0.8 × 0.4]	SOT563-6 [1.6 × 1.6 × 0.6]
<b>Features</b>							
Address #	4	4	4	4	4	4	4
Address & Alert Programming	Address + Alert	Address or Alert	Address + Alert			Address or Alert	Address + Alert

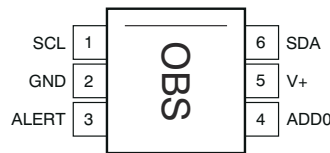
## 5 Pin Configuration and Functions



DPW Package  
5-Pin X2SON  
TMP112D  
(Top View)



DPW Package  
5-Pin X2SON  
TMP112D0/D1/D2/D3  
(Top View)



DRL Package  
6-Pin SOT563  
(Top View)

Table 5-1. Pin Function

NAME	PIN			Type <sup>(1)</sup>	DESCRIPTION
	NO. TMP112A/B/N	NO. TMP112D	NO. TMP112D0 /1/2/3		
SCL	1	2	2	I	Serial clock
GND	2	1	1	—	Ground <b>Pin-1 has curved edges in TMP112Dx.</b>
ALERT	3	-	3	O	Overtemperature alert. Open-drain output; requires a pullup resistor. <b>Note:</b> Connecting to GND if Alert pin is not used is preferred.
ADD0	4	3	-	I	Address Select. Connect to V+, GND, SDA or SCL
V+	5	5	5	I	Supply voltage, 1.4 V to 3.6 V
SDA	6	4	4	I/O	Serial data. Open-drain output; requires a pullup resistor.

(1) I = Input; O = Output, I/O = Input or Output

## 6 Specifications

### 6.1 Absolute Maximum Ratings

Over free-air temperature range unless otherwise noted<sup>(1)</sup>

	MIN	MAX	UNIT
Supply voltage (V+)		4	V
Voltage at SCL, ADD0, and SDA	-0.5	4	V
Voltage at ALERT		((V+) + 0.3) and ≤ 4	V
Output current		±10	mA
Operating temperature	-55	150	°C
Junction temperature, T <sub>J</sub>		150	°C
Storage temperature, T <sub>stg</sub>	-60	150	°C

- (1) Operation outside the *Absolute Maximum Ratings* may cause permanent device damage. *Absolute Maximum Ratings* do not imply functional operation of the device at these or any other conditions beyond those listed under *Recommended Operating Conditions*. If used outside the *Recommended Operating Conditions* but within the *Absolute Maximum Ratings*, the device may not be fully functional, and this may affect device reliability, functionality, performance, and shorten the device lifetime.

### 6.2 Handling Ratings

			VALUE	UNIT
V <sub>(ESD)</sub>	Electrostatic discharge	Human-body model (HBM), per ANSI/ESDA/JEDEC JS-001 <sup>(1)</sup>	±2000	V
		Charged-device model (CDM), per JEDEC specification JESD22-C101 <sup>(2)</sup>	±1000	

- (1) JEDEC document JEP155 states that 500-V HBM allows safe manufacturing with a standard ESD control process.  
(2) JEDEC document JEP157 states that 250-V CDM allows safe manufacturing with a standard ESD control process.

### 6.3 Recommended Operating Conditions

over operating free-air temperature range (unless otherwise noted)

		MIN	NOM	MAX	UNIT
V+	Supply voltage	1.4	3.3	3.6	V
T <sub>A</sub>	Operating free-air temperature	-40		125	°C

### 6.4 Thermal Information

THERMAL METRIC <sup>(1)</sup>		TMP112A/B/N	TMP112Dx	UNIT
		DRL (SOT563)	DPW (X2SON)	
		6 PINS	5 PINS	
R <sub>θJA</sub>	Junction-to-ambient thermal resistance	240.2	230	°C/W
R <sub>θJC(top)</sub>	Junction-to-case (top) thermal resistance	96.4	194	°C/W
R <sub>θJB</sub>	Junction-to-board thermal resistance	124.3	158.4	°C/W
ψ <sub>JT</sub>	Junction-to-top characterization parameter	4.0	20	°C/W
ψ <sub>JB</sub>	Junction-to-board characterization parameter	123.1	158.3	°C/W
R <sub>θJC(bot)</sub>	Junction-to-case (bottom) thermal resistance	N/A	108.4	°C/W
M <sub>T</sub>	Thermal Mass	TBD	TBD	mJ/°C

- (1) For more information about traditional and new thermal metrics, see the [Semiconductor and IC Package Thermal Metrics application note](#).

## 6.5 Electrical Characteristics

At  $T_A = 25^\circ\text{C}$  and  $V_S = 1.4$  to  $3.6\text{V}$ , unless otherwise noted

PARAMETER		TEST CONDITIONS	MIN	TYP	MAX	UNIT
<b>TEMPERATURE SENSOR</b>						
	Temperature range		-40		125	$^\circ\text{C}$
Accuracy (temperature error)	TMP112A	25 $^\circ\text{C}$ , $V_+ = 3.3\text{V}$		$\pm 0.1$	$\pm 0.5$	$^\circ\text{C}$
		0 $^\circ\text{C}$ to +65 $^\circ\text{C}$ , $V_+ = 3.3\text{V}$		$\pm 0.25$	$\pm 0.5$	
		-40 $^\circ\text{C}$ to +125 $^\circ\text{C}$		$\pm 0.5$	$\pm 1$	
	TMP112B	25 $^\circ\text{C}$ , $V_+ = 1.8\text{V}$		$\pm 0.1$	$\pm 0.5$	
		0 $^\circ\text{C}$ to +65 $^\circ\text{C}$ , $V_+ = 1.8\text{V}$		$\pm 0.25$	$\pm 0.5$	
		-40 $^\circ\text{C}$ to +125 $^\circ\text{C}$		$\pm 0.5$	$\pm 1$	
	TMP112Dx	25 $^\circ\text{C}$		TBD	$\pm 0.5$	
		-25 $^\circ\text{C}$ to +85 $^\circ\text{C}$ , $V_+ \geq 1.5\text{V}$		TBD	$\pm 0.5$	
		-40 $^\circ\text{C}$ to +125 $^\circ\text{C}$		TBD	$\pm 1$	
TMP112N	-40 $^\circ\text{C}$ to +125 $^\circ\text{C}$			$\pm 1$		
	DC power-supply sensitivity	-40 $^\circ\text{C}$ to +125 $^\circ\text{C}$		0.0625	$\pm 0.25$	$^\circ\text{C}/\text{V}$
	Long-term drift <sup>(1)</sup>	3000 hours at 125 $^\circ\text{C}$		$\pm 0.0625$		$^\circ\text{C}$
	Resolution (LSB)			0.0625		$^\circ\text{C}$
<b>DIGITAL INPUT/OUTPUT</b>						
	Input capacitance			3		pF
$V_{IH}$	Input logic level		$0.7 \times (V_+)$		3.6	V
$V_{IL}$			-0.5		$0.3 \times (V_+)$	
$I_{IN}$	Input current	TMP112A/B/N	$0 < V_{IN} < 3.6\text{V}$		1	$\mu\text{A}$
		TMP112Dx			0.1	$\mu\text{A}$
$V_{OL\ SDA}$	Output low level	$V_+ > 2\text{V}$ , $I_{OL} = 3\text{mA}$	0		0.4	V
$V_{OL\ ALERT}$		$V_+ < 2\text{V}$ , $I_{OL} = 3\text{mA}$	0		$0.2 \times (V_+)$	
		$V_+ > 2\text{V}$ , $I_{OL} = 3\text{mA}$	0		0.4	
		$V_+ < 2\text{V}$ , $I_{OL} = 3\text{mA}$	0		$0.2 \times (V_+)$	
	Resolution			12		Bits
	Conversion time	TMP112A/B/N		26	35	ms
		TMP112Dx		10.25	11.25	ms
	Conversion modes	CR1 = 0, CR0 = 0		0.25		Conv/s
		CR1 = 0, CR0 = 1		1		
		CR1 = 1, CR0 = 0 (default)		4		
		CR1 = 1, CR0 = 1		8		
	Timeout time (SCL = GND or SDA = GND)			30	40	ms
<b>POWER SUPPLY</b>						
	Operating supply range		+1.4		+3.6	V

At  $T_A = 25^\circ\text{C}$  and  $V_S = 1.4$  to  $3.6\text{V}$ , unless otherwise noted

PARAMETER		TEST CONDITIONS	MIN	TYP	MAX	UNIT	
$I_Q$	Average quiescent current	TMP112A/B/N	Serial bus inactive, CR1 = 0, CR0 = 1		3.2		$\mu\text{A}$
			Serial bus inactive, CR1 = 1, CR0 = 0 (default)		7	10	
			Serial bus active, SCL frequency = 400 kHz		15		
			Serial bus active, SCL frequency = 3.4 MHz		85		
		TMP112Dx	Serial bus inactive, CR1 = 0, CR0 = 1		3.2		
			Serial bus inactive, CR1 = 1, CR0 = 0 (default)		4.8		
			Serial bus active, SCL frequency = 400 kHz		TBD		
			Serial bus active, SCL frequency = 1 MHz		TBD		
$I_{SD}$	Shutdown current	TMP112A/B/N	Serial bus inactive		0.5	1	$\mu\text{A}$
			Serial bus active, SCL frequency = 400 kHz		10		
			Serial bus active, SCL frequency = 3.4 MHz		80		
		TMP112Dx	Serial bus inactive		0.15		
			Serial bus active, SCL frequency = 400 kHz		5.5		
			Serial bus active, SCL frequency = 1 MHz		13		

 (1) Long-term drift is determined using accelerated operational life testing at a junction temperature of  $150^\circ\text{C}$  for 1000 hours.

## 6.6 Timing Requirements

See the Two-Wire Timing Diagrams section for timing diagrams.

			FAST MODE		FAST MODE PLUS		HIGH-SPEED MODE		UNIT
			MIN	MAX	MIN	MAX	MIN	MAX	
$f_{(SCL)}$	SCL operating frequency	TMP112A/B/N	0.001	0.4	TBD	TBD	0.001	2.85	MHz
		TMP112Dx	0.001	0.4	0.001	1	TBD	TBD	
$t_{(BUF)}$	Bus-free time between STOP and START conditions		600	–	500		160	–	ns
$t_{(HDSTA)}$	Hold time after repeated START condition. After this period, the first clock is generated.		600	–	260		160	–	ns
$t_{(SUSTA)}$	Repeated START condition setup time		600	–	260		160	–	ns
$t_{(SUSTO)}$	STOP condition setup time		600	–	260		160	–	ns
$t_{(HDDAT)}$	Data hold time		100	900	12	150	25	105	ns
$t_{(SUDAT)}$	Data setup time		100	–	50		25	–	ns
$t_{(LOW)}$	SCL clock low period	V+	1300	–	500		210	–	ns
$t_{(HIGH)}$	SCL clock high period		600	–	260		60	–	ns
$t_{(FD)}$	Data fall time		–	300		120	–	80	ns
$t_{(RD)}$	Data rise time		–	300	–	120	–	–	ns
		SCLK $\leq$ 100 kHz	–	1000	–	–	–	–	ns
$t_{(FC)}$	Clock fall time		–	300	–	120	–	40	ns
$t_{(RC)}$	Clock rise time		–	300	–	120	–	40	ns

## 6.7 Timing Diagrams

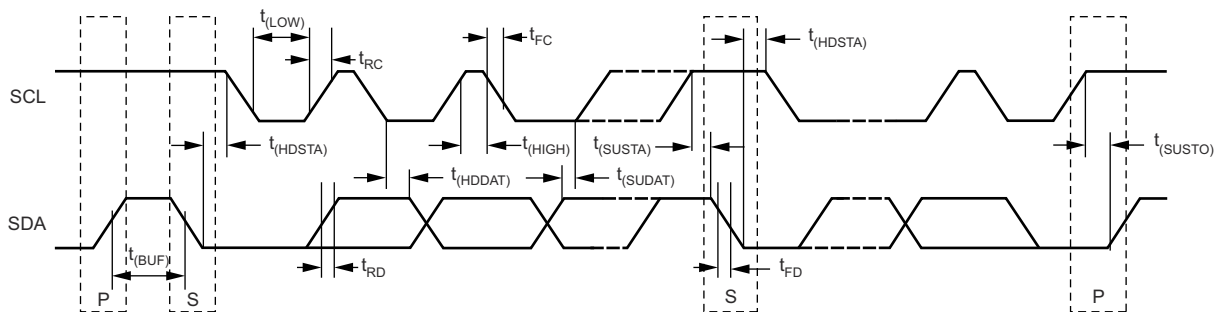
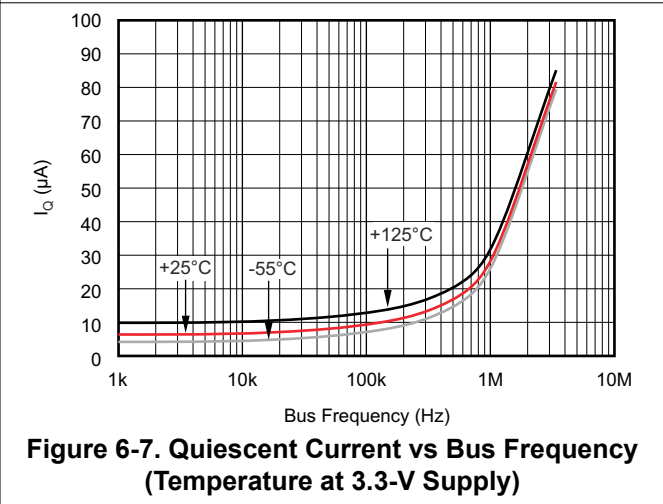
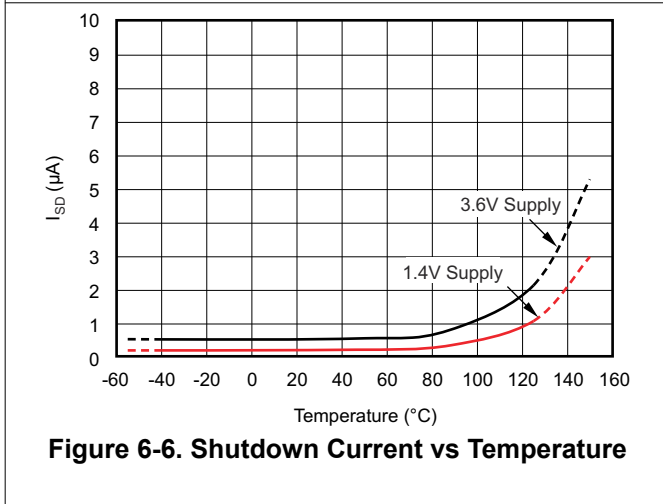
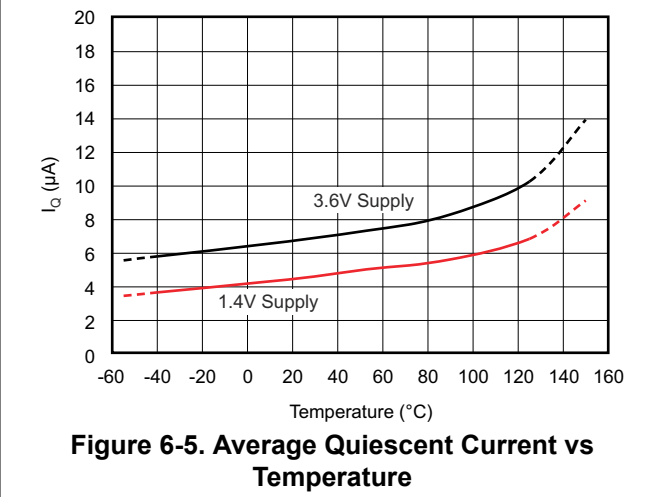
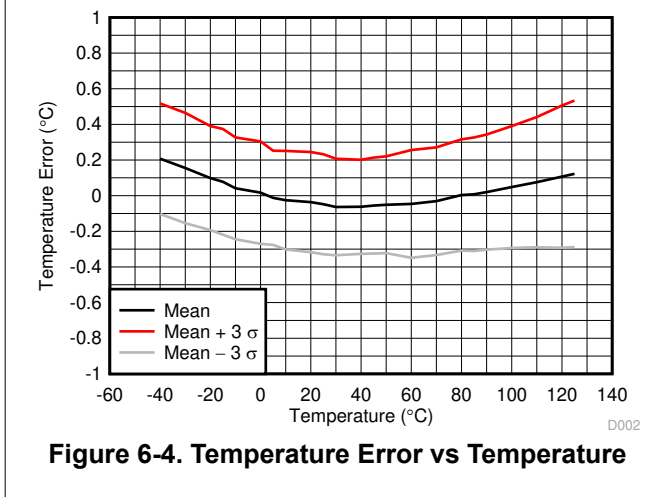
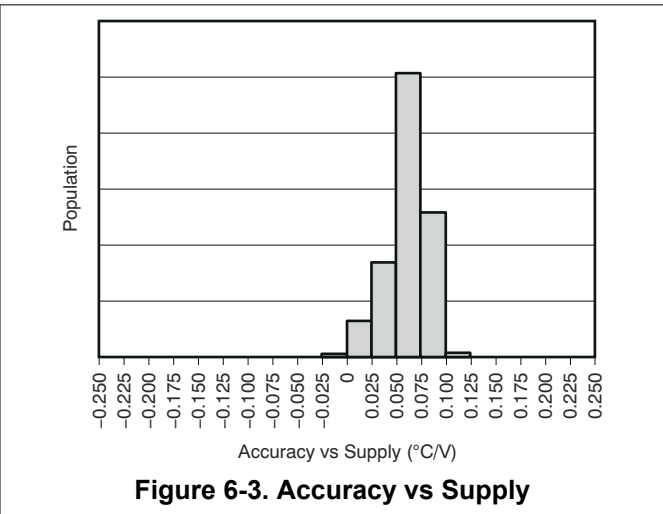
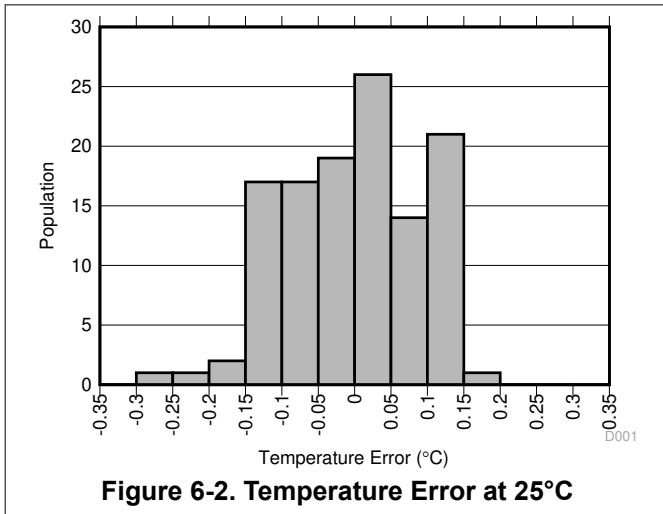
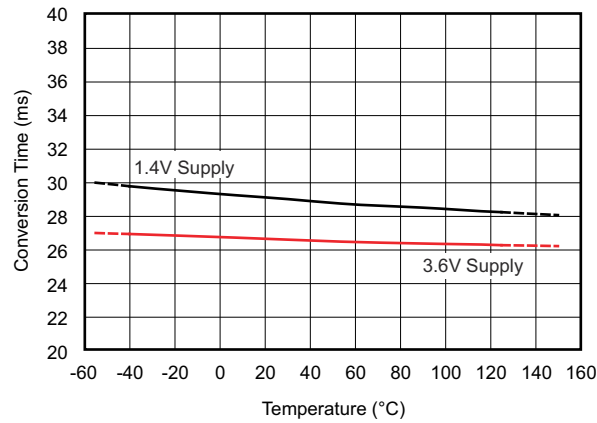


Figure 6-1. Two-Wire Timing Diagram

### 6.8 Typical Characteristics (TMP112A/B/N)

At  $T_A = 25^\circ\text{C}$  and  $V_+ = 3.3\text{ V}$ , unless otherwise noted.



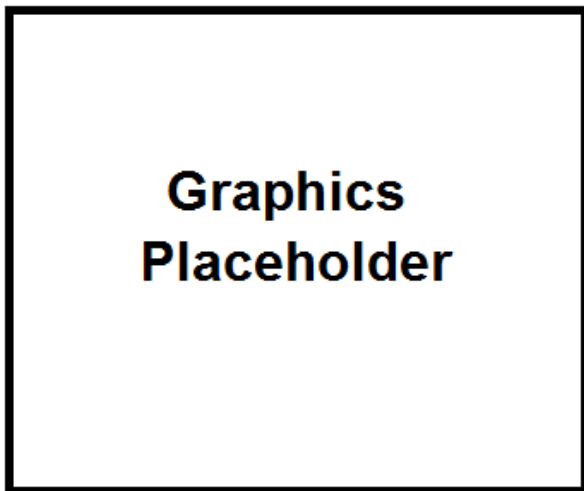


**Figure 6-8. Conversion Time vs Temperature**

### 6.9 Typical Characteristics (TMP112Dx)

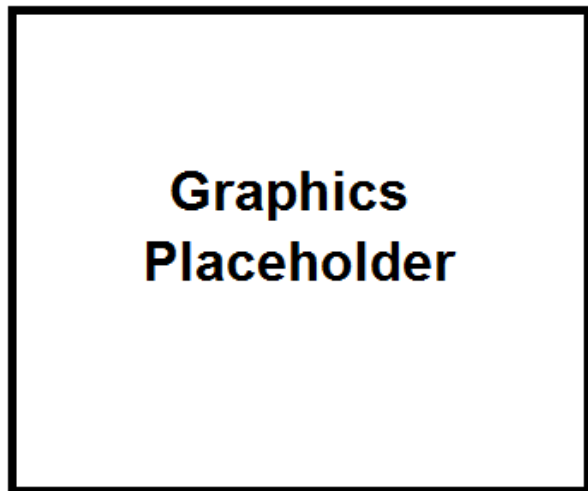
at  $T_A = 25^\circ\text{C}$  and  $V_+ = 3.3\text{ V}$  (unless otherwise noted)

$V_+ = 3.3\text{ V}$  for Mean, Mean +  $3\sigma$ , Mean -  $3\sigma$



**Figure 6-9. Temperature Error vs Temperature**

$V_+ = 1.4\text{ V}$  to  $3.6\text{ V}$ ;  $T_A = -40^\circ\text{C}$ ,  $25^\circ\text{C}$ ,  $125^\circ\text{C}$



**Figure 6-10. Temperature Error vs Supply Voltage**

## 6.9 Typical Characteristics (TMP112Dx) (continued)

at  $T_A = 25^\circ\text{C}$  and  $V_+ = 3.3\text{ V}$  (unless otherwise noted)

$V_+ = 1.4\text{ V}, 1.8\text{ V}, 2.5\text{ V}, 3.3\text{ V}, 3.6\text{ V}$  and Four conversions per second

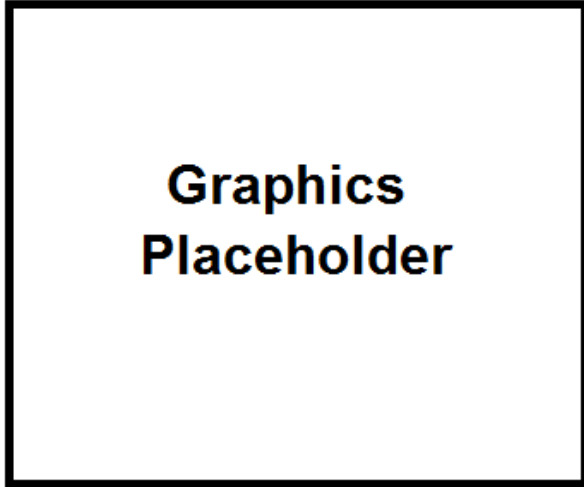


Figure 6-11. Average Quiescent Current vs Temperature

$V_+ = 1.4\text{ V}, 1.8\text{ V}, 2.5\text{ V}, 3.3\text{ V}, 3.6\text{ V}$

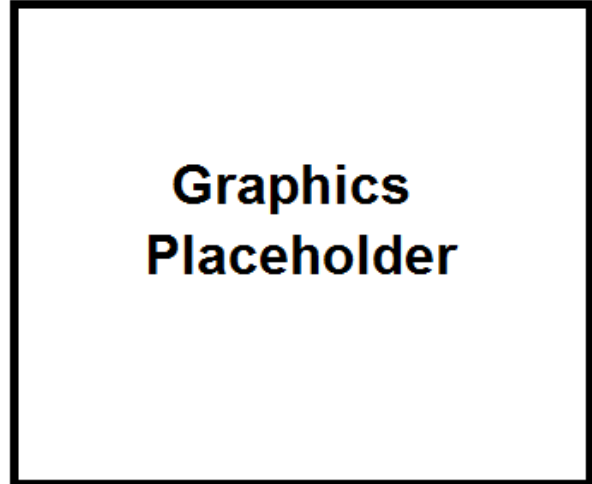


Figure 6-12. Conversion Current vs Temperature

$V_+ = 1.4\text{ V}, 1.8\text{ V}, 2.5\text{ V}, 3.3\text{ V}, 3.6\text{ V}$

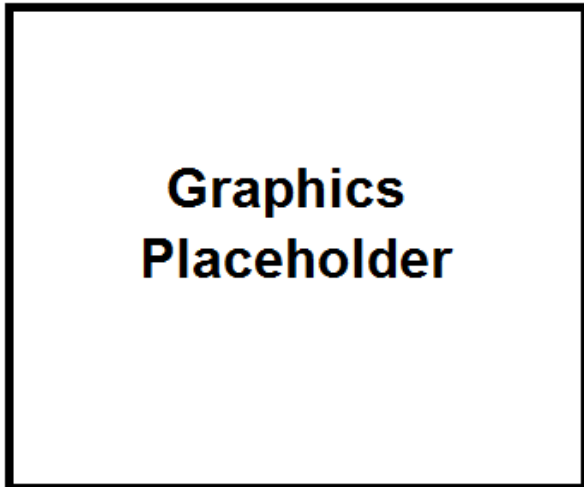


Figure 6-13. Shutdown Current vs Temperature

$V_+ = 1.4\text{ V}, 1.8\text{ V}, 2.5\text{ V}, 3.3\text{ V}, 3.6\text{ V}$

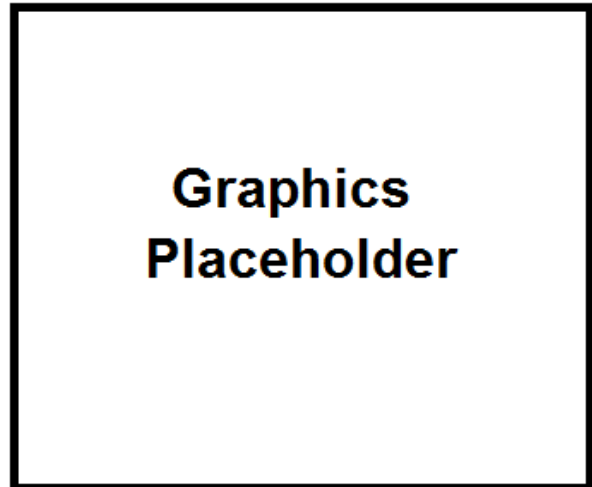


Figure 6-14. Standby Current vs Temperature

### 6.9 Typical Characteristics (TMP112Dx) (continued)

at  $T_A = 25^\circ\text{C}$  and  $V_+ = 3.3\text{ V}$  (unless otherwise noted)

$T_A = -40^\circ\text{C}, 25^\circ\text{C}, 125^\circ\text{C}$

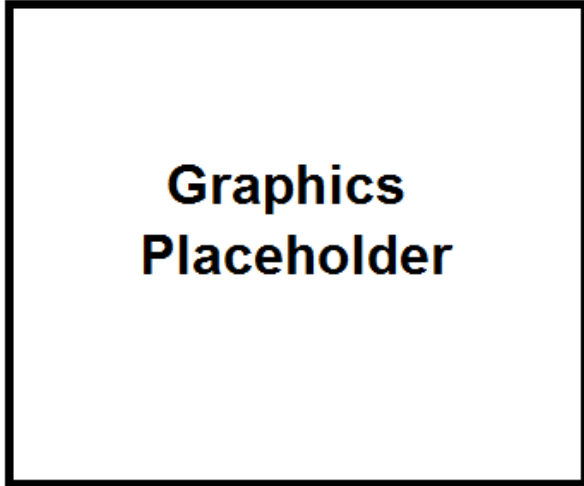


Figure 6-15. Quiescent Current vs Bus Frequency (Temperature at 3.3-V Supply)

$V_+ = 1.4\text{ V}, 1.8\text{ V}, 2.5\text{ V}, 3.3\text{ V}, 3.6\text{ V}$

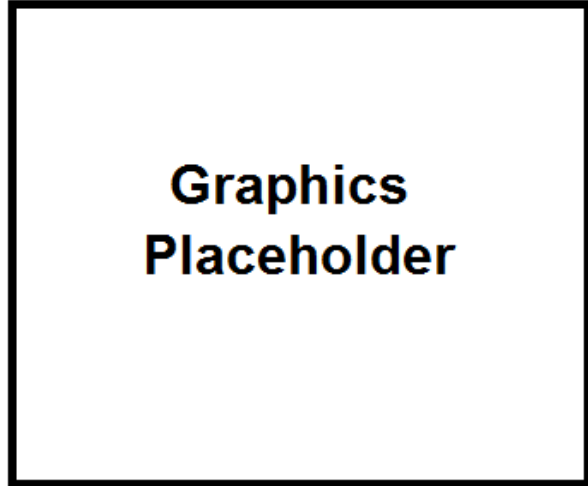


Figure 6-16. Conversion Time vs Temperature

$V_+ = 3.3\text{ V}$

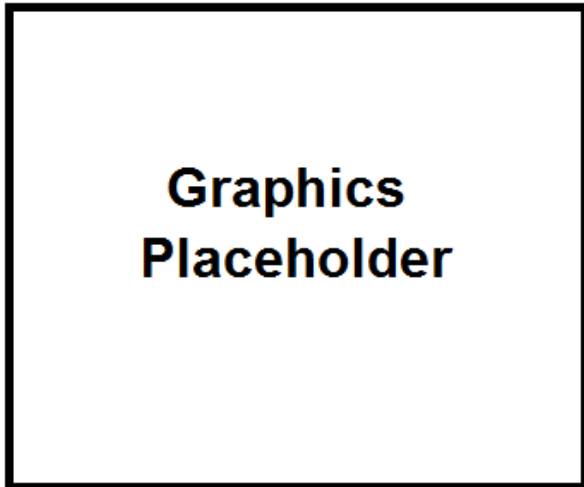


Figure 6-17. Average Supply Current vs Conversion Rate

$V_+ = 3.3\text{ V}$

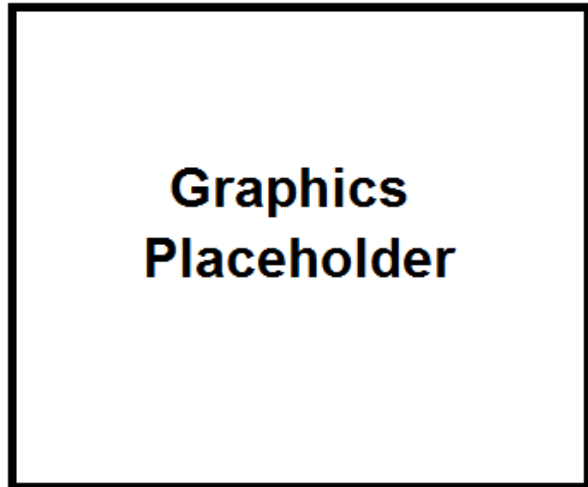


Figure 6-18. Temperature Error at  $25^\circ\text{C}$

## 6.9 Typical Characteristics (TMP112Dx) (continued)

at  $T_A = 25^\circ\text{C}$  and  $V_+ = 3.3\text{ V}$  (unless otherwise noted)

$V_+ = 1.4\text{ V}, 1.8\text{ V}, 2.5\text{ V}, 3.3\text{ V}, 3.6\text{ V}$

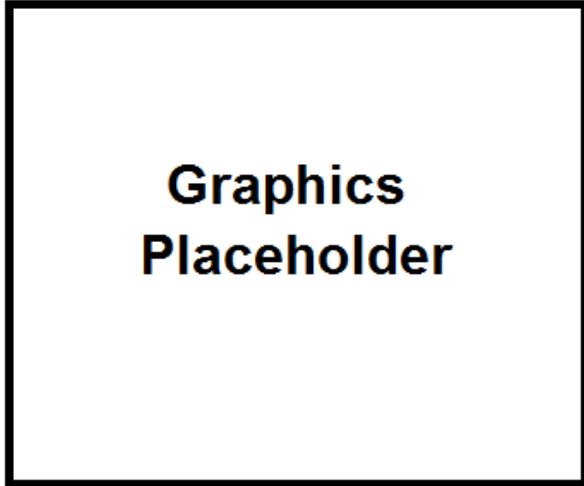


Figure 6-19. Sampling Time vs Temperature

$V_+ = 1.4\text{ V}, 1.8\text{ V}, 2.5\text{ V}, 3.3\text{ V}, 3.6\text{ V}$

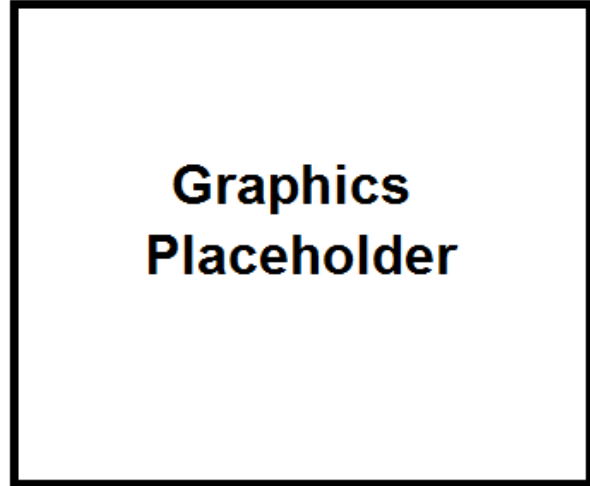


Figure 6-20. ALERT Pin Output Voltage vs Pin Sink Current

$V_+ = 3.3\text{ V}; T_A = -40^\circ\text{C}, 25^\circ\text{C}, 125^\circ\text{C}$

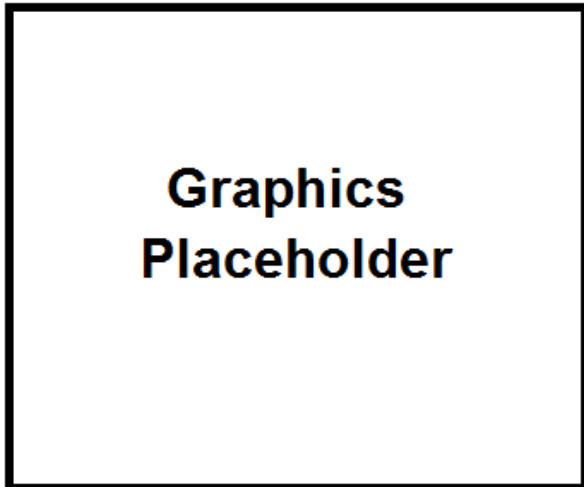


Figure 6-21. Noise Histogram

$V_+ = 1.4\text{ V}, 1.8\text{ V}, 2.5\text{ V}, 3.3\text{ V}, 3.6\text{ V}$

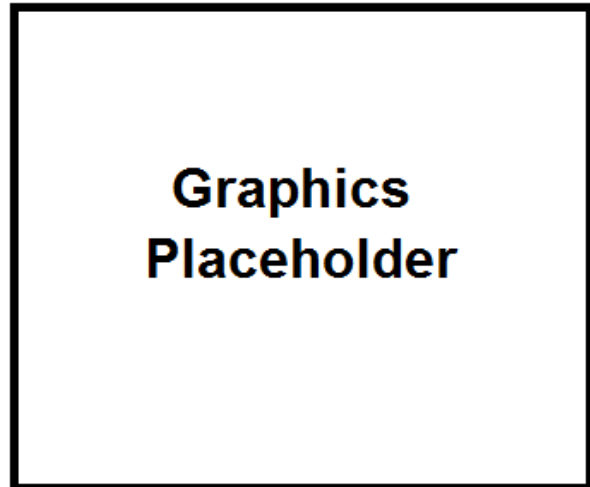


Figure 6-22. Supply Current vs Input Cell Input Voltage

## 7 Detailed Description

### 7.1 Overview

The TMP112 family of devices are digital temperature sensors that are designed for thermal-management and thermal-protection applications. The TMP112 family is two-wire, SMBus, and I<sup>2</sup>C interface-compatible. The device is specified over an operating temperature range of –40°C to 125°C. Figure 7-1 and Figure 7-2 show block diagrams of the TMP112 family. Figure 7-3 shows the ESD protection circuitries contained in the TMP112 family.

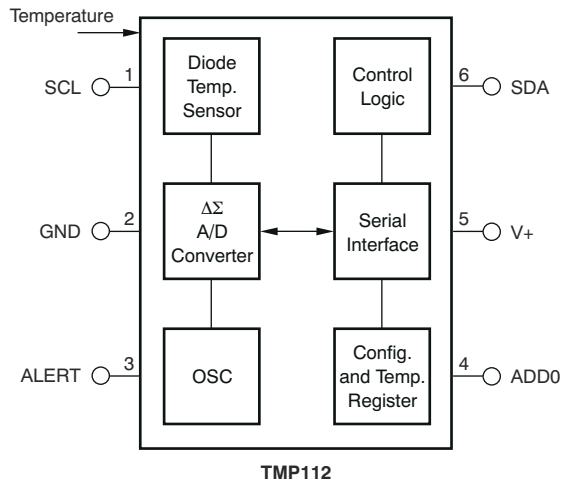
The temperature sensor in the TMP112 family is the chip itself. Thermal paths run through the package leads as well as the plastic package. The package leads provide the primary thermal path because of the lower thermal resistance of the metal.

An alternative version of the TMP112 family is available. The TMP102 device has reduced accuracy, the same micro-package, and is pin-to-pin compatible.

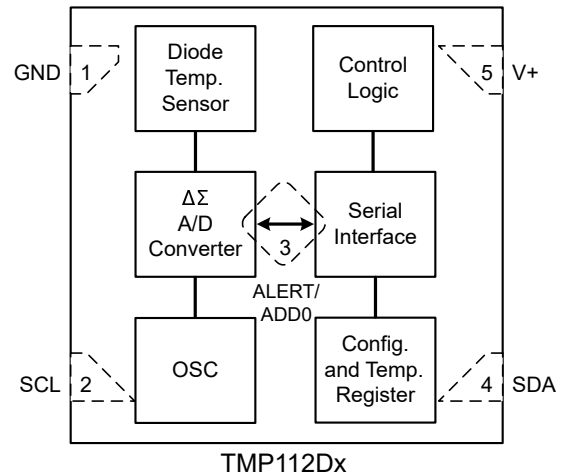
**Table 7-1. Advantages of TMP112 Family Versus TMP102 and TMP110**

DEVICE	COMPATIBLE INTERFACES	PACKAGE	SUPPLY CURRENT (Typ)	SUPPLY VOLTAGE (MIN)	SUPPLY VOLTAGE (MAX)	RESOLUTION	LOCAL SENSOR ACCURACY (MAX)	SPECIFIED CALIBRATION DRIFT SLOPE
TMP112A/B/N	I <sup>2</sup> C SMBus	SOT563 1.6 × 1.6 × 0.6	7µA (at 4-Hz) 3.2µA (at 1-Hz)	1.4 V	3.6 V	12 Bit 0.0625°C	±0.5°C: (0°C to 65°C) ±1°C: (-40°C to 125°C)	Yes
TMP112Dx	I <sup>2</sup> C SMBus	X2SON 0.8 × 0.8 × 0.4	3.2µA (at 1-Hz)	1.4 V	3.6 V	12 Bit 0.0625°C	±0.5°C: (-25°C to 85°C) ±1°C: (-40°C to 125°C)	Yes
TMP110	I <sup>2</sup> C SMBus	X2SON 0.8 × 0.8 × 0.4	3.2µA (at 1-Hz)	1.14 V	5.5 V	12 Bit 0.0625°C	±1°C: (-40°C to 125°C)	Yes
TMP102	I <sup>2</sup> C SMBus	SOT563 1.6 × 1.6 × 0.6	7µA (at 4-Hz)	1.4 V	3.6 V	12 Bit 0.0625°C	±2°C: (25°C to 85°C) ±3°C: (-40°C to 125°C)	No

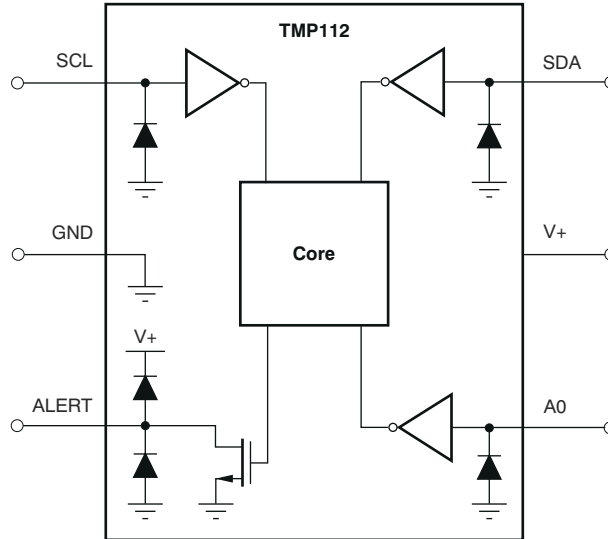
### 7.2 Functional Block Diagrams



**Figure 7-1. Internal Block Diagram (SOT563-6 Package)**



**Figure 7-2. Internal Block Diagram (X2SON-5 Package)**



**Figure 7-3. Equivalent Internal ESD Circuitry (SOT563-6 Package)**

## 7.3 Feature Description

### 7.3.1 Digital Temperature Output

The digital output from each temperature measurement conversion is stored in the read-only temperature register. The temperature register of the TMP112 family is configured as a 12-bit read-only register (setting the EM bit to 0 in the configuration register; see [Section 7.5.3.7](#)), or as a 13-bit read-only register (setting the EM bit to 1 in the configuration register) that stores the output of the most recent conversion. Two bytes must be read to obtain data and are listed in [Table 7-8](#) and [Table 7-9](#). Byte 1 is the most significant byte (MSB), followed by byte 2, the least significant byte (LSB). The first 12 bits (13 bits in extended mode) are used to indicate temperature. The least significant byte does not have to be read if that information is not needed. The data format for temperature is listed in [Table 7-2](#) and [Table 7-3](#). One LSB equals 0.0625°C. Negative numbers are represented in binary two's complement format. Following power up or reset, the temperature register reads 0°C until the first conversion is complete. Bit D0 of byte 2 indicates normal mode (EM bit equals 0) or extended mode (EM bit equals 1), and can be used to distinguish between the two temperature register data formats. The unused bits in the temperature register always read 0.

**Table 7-2. 12-Bit Temperature Data Format**

TEMPERATURE (°C)	DIGITAL OUTPUT (BINARY)	HEX
128	0111 1111 1111	7FF
127.9375	0111 1111 1111	7FF
100	0110 0100 0000	640
80	0101 0000 0000	500
75	0100 1011 0000	4B0
50	0011 0010 0000	320
25	0001 1001 0000	190
0.25	0000 0000 0100	004
0.0625	0000 0000 0001	001
0	0000 0000 0000	000
-0.0625	1111 1111 1111	FFF
-0.25	1111 1111 1100	FFC
-25	1110 0111 0000	E70
-55	1100 1001 0000	C90

Table 7-2 does not list all temperatures. Use the following rules to obtain the digital data format for a given temperature or the temperature for a given digital data format.

To convert positive temperatures to a digital data format:

1. Divide the temperature by the resolution
2. Convert the result to binary code with a 12-bit, left-justified format, and MSB = 0 to denote a positive sign.

Example:  $(50^{\circ}\text{C}) / (0.0625^{\circ}\text{C} / \text{LSB}) = 800 = 320\text{h} = 0011\ 0010\ 0000$

To convert a positive digital data format to temperature:

1. Convert the 12-bit, left-justified binary temperature result, with the MSB = 0 to denote a positive sign, to a decimal number.
2. Multiply the decimal number by the resolution to obtain the positive temperature.

Example:  $0011\ 0010\ 0000 = 320\text{h} = 800 \times (0.0625^{\circ}\text{C} / \text{LSB}) = 50^{\circ}\text{C}$

To convert negative temperatures to a digital data format:

1. Divide the absolute value of the temperature by the resolution, and convert the result to binary code with a 12-bit, left-justified format.
2. Generate the twos complement of the result by complementing the binary number and adding one. Denote a negative number with MSB = 1.

Example:  $(|-25^{\circ}\text{C}|) / (0.0625^{\circ}\text{C} / \text{LSB}) = 400 = 190\text{h} = 0001\ 1001\ 0000$

Two's complement format:  $1110\ 0110\ 1111 + 1 = 1110\ 0111\ 0000$

To convert a negative digital data format to temperature:

1. Generate the twos complement of the 12-bit, left-justified binary number of the temperature result (with MSB = 1, denoting negative temperature result) by complementing the binary number and adding one. This represents the binary number of the absolute value of the temperature.
2. Convert to decimal number and multiply by the resolution to get the absolute temperature, then multiply by -1 for the negative sign.

Example:  $1110\ 0111\ 0000$  has twos complement of  $0001\ 1001\ 0000 = 0001\ 1000\ 1111 + 1$

Convert to temperature:  $0001\ 1001\ 0000 = 190\text{h} = 400; 400 \times (0.0625^{\circ}\text{C} / \text{LSB}) = 25^{\circ}\text{C} = (|-25^{\circ}\text{C}|); (|-25^{\circ}\text{C}|) \times (-1) = -25^{\circ}\text{C}$

**Table 7-3. 13-Bit Temperature Data Format**

TEMPERATURE (°C)	DIGITAL OUTPUT (BINARY)	HEX
150	0 1001 0110 0000	0960
128	0 1000 0000 0000	0800
127.9375	0 0111 1111 1111	07FF
100	0 0110 0100 0000	0640
80	0 0101 0000 0000	0500
75	0 0100 1011 0000	04B0
50	0 0011 0010 0000	0320
25	0 0001 1001 0000	0190
0.25	0 0000 0000 0100	0004
0.0625	0 0000 0000 0001	0001
0	0 0000 0000 0000	0000
-0.0625	1 1111 1111 1111	1FFF
-0.25	1 1111 1111 1100	1FFC
-25	1 1110 0111 0000	1E70
-55	1 1100 1001 0000	1C90

### 7.3.2 Serial Interface

The TMP112 family operates as a slave device only on the SMBus, two-wire, and I<sup>2</sup>C interface-compatible bus. Connections to the bus are made through the open-drain I/O lines, SDA and SCL. The SDA and SCL pins feature integrated spike suppression filters and Schmitt triggers to minimize the effects of input spikes and bus noise. The TMP112 family supports the transmission protocol for fast (1 kHz to 400 kHz), fast-plus (1 kHz to 1 MHz) and high-speed (1 kHz to 2.85 MHz) modes. All data bytes are transmitted MSB first.

#### 7.3.2.1 Bus Overview

The device that initiates the transfer is called a *master*, and the devices controlled by the master are *slaves*. The bus must be controlled by a master device that generates the serial clock (SCL), controls the bus access, and generates the START and STOP conditions.

To address a specific device, a START condition is initiated, indicated by pulling the data-line (SDA) from a high-to low-logic level when the SCL pin is high. All slaves on the bus shift in the slave address byte on the rising edge of the clock, with the last bit indicating whether a read or write operation is intended. During the ninth clock pulse, the slave being addressed responds to the master by generating an acknowledge and pulling the SDA pin low.

A data transfer is then initiated and sent over eight clock pulses followed by an acknowledge bit. During the data transfer the SDA pin must remain stable when the SCL pin is high, because any change in the SDA pin when the SCL pin is high is interpreted as a START or STOP signal.

When all data have been transferred, the master generates a STOP condition indicated by pulling the SDA pin from low to high when the SCL pin is high.

#### 7.3.2.2 Serial Bus Address

To communicate with the device, the master must first address slave devices through a slave-address byte. The slave-address byte consists of seven address bits and a direction bit indicating the intent of executing a read or write operation.

The TMP112 family features an address pin to allow up to four devices to be addressed on a single bus. [Table 7-4](#) describes the pin logic levels used to properly connect up to four devices. This table also describes four different address options available when ALERT pin is used in TMP112Dx.

**Table 7-4. Address and Alert Variant Device Target Address**

DEVICE ORDERABLE		ADD0 PIN CONNECTION	DEVICE I <sup>2</sup> C BUS ADDRESS	DEVICE I <sup>2</sup> C BUS ADDRESS (Hex)
Address Variant Only	TMP112D	GND	1000000	40h
		V+	1000001	41h
		SDA	1000010	42h
		SCL	1000011	43h
Alert Variant Only	TMP112D0	N/A	1001000	48h
	TMP112D1		1001001	49h
	TMP112D2		1001010	4Ah
	TMP112D3		1001011	4Bh
Address + Alert Variant	TMP112A TMP112B TMP112N	GND	1001000	48h
		V+	1001001	49h
		SDA	1001010	4Ah
		SCL	1001011	4Bh

#### 7.3.2.3 Writing and Reading Operation

Accessing a particular register on the TMP112 family is accomplished by writing the appropriate value to the pointer register. The value for the pointer register is the first byte transferred after the slave address byte with the R/W bit low. Every write operation to the TMP112 family requires a value for the pointer register (see [Figure 7-4](#)).

When reading from the TMP112 family, the last value stored in the pointer register by a write operation is used to determine which register is read by a read operation. To change the register pointer for a read operation, a new value must be written to the pointer register. This action is accomplished by issuing a slave-address byte with the R/W bit low, followed by the pointer register byte. No additional data are required. The master can then generate a START condition and send the slave address byte with the R/W bit high to initiate the read command. See [Figure 7-5](#) for details of this sequence. If repeated reads from the same register are desired, continuously sending the pointer register bytes is not necessary because the TMP112 family retains the pointer register value until the value is changed by the next write operation.

Register bytes are sent with the most significant byte first, followed by the least significant byte.

#### 7.3.2.4 Slave Mode Operations

The TMP112 family can operate as a slave receiver or slave transmitter. As a slave device, the TMP112 family never drives the SCL line.

##### 7.3.2.4.1 Slave Receiver Mode

The first byte transmitted by the master is the slave address with the R/W bit low. The TMP112 family then acknowledges reception of a valid address. The next byte transmitted by the master is the pointer register. The TMP112 family then acknowledges reception of the pointer register byte. The next byte or bytes are written to the register addressed by the pointer register. The TMP112 family acknowledges reception of each data byte. The master can terminate data transfer by generating a START or STOP condition.

##### 7.3.2.4.2 Slave Transmitter Mode

The first byte transmitted by the master is the slave address with the R/W bit high. The slave acknowledges reception of a valid slave address. The next byte is transmitted by the slave and is the most significant byte of the register indicated by the pointer register. The master acknowledges reception of the data byte. The next byte transmitted by the slave is the least significant byte. The master acknowledges reception of the data byte. The master can terminate data transfer by generating a *not-acknowledge* on reception of any data byte or by generating a START or STOP condition.

#### 7.3.2.5 SMBus Alert Function

The TMP112 family supports the SMBus alert function. When the TMP112 family operates in interrupt mode (TM = 1), the ALERT pin can be connected as an SMBus alert signal (when the ALERT pin is available). Irrespective of the availability of the ALERT pin, the alert status is set. When a master senses that an alert condition is present on the alert line, the master sends an SMBus ALERT command (0001 1001) to the bus. If the ALERT pin is active or the alert is set, the device acknowledges the SMBus ALERT command and responds by returning the slave address on the SDA line. The eighth bit (LSB) of the slave address byte indicates if the alert condition is caused by the temperature exceeding  $T_{(HIGH)}$  or falling below  $T_{(LOW)}$ . The LSB is high if the temperature is greater than  $T_{(HIGH)}$ , or low if the temperature is less than  $T_{(LOW)}$ . Refer to the [Figure 7-6](#) section for details of this sequence.

If multiple devices on the bus respond to the SMBus ALERT command, arbitration during the slave address portion of the SMBus ALERT command determines which device clears the alert status of that device. The device with the lowest two-wire address wins the arbitration. If the TMP112 family wins the arbitration, the TMP112 family ALERT pin becomes inactive and/or clears the status bit at the completion of the SMBus ALERT command. If the TMP112 family loses the arbitration, the TMP112 family ALERT pin and/or the status bit remains active.

#### 7.3.2.6 General Call

The TMP112 family responds to a two-wire general-call address (0000 000) if the eighth bit is 0. The device acknowledges the general-call address and responds to commands in the second byte. If the second byte is 0000 0110, the TMP112 family internal registers are reset to power-up values. The TMP112 family does not support the general-address acquire command.

### 7.3.2.7 High-Speed (Hs) Mode

For the two-wire bus to operate at frequencies above 400 kHz, the master device must issue a Hs-mode master code (0000 1xxx) as the first byte after a START condition to switch the bus to high-speed operation. The TMP112 family does not acknowledge this byte, but switches the input filters on the SDA and SCL pins and the output filters on the SDA pin to operate in Hs-mode, thus allowing transfers at up to 2.85 MHz. After the Hs-mode master code has been issued, the master transmits a two-wire slave address to initiate a data-transfer operation. The bus continues to operate in Hs-mode until a STOP condition occurs on the bus. Upon receiving the STOP condition, the TMP112 family switches the input and output filters back to fast-mode operation.

### 7.3.2.8 Timeout Function

The TMP112 family resets the serial interface if the SCL pin is held low for 30 ms (typical) between a start and stop condition. The TMP112 family releases the SDA line if the SCL pin is pulled low and waits for a start condition from the host controller. To avoid activating the timeout function, maintain a communication speed of at least 1 kHz for SCL operating frequency.

### 7.3.2.9 Timing Diagrams

The TMP112 family is two-wire, SMBus and I<sup>2</sup>C interface-compatible. [Figure 7-4](#) to [Figure 7-6](#) describe the various operations on the TMP112 family. Bus definitions are:

**Bus Idle:** Both SDA and SCL lines remain high.

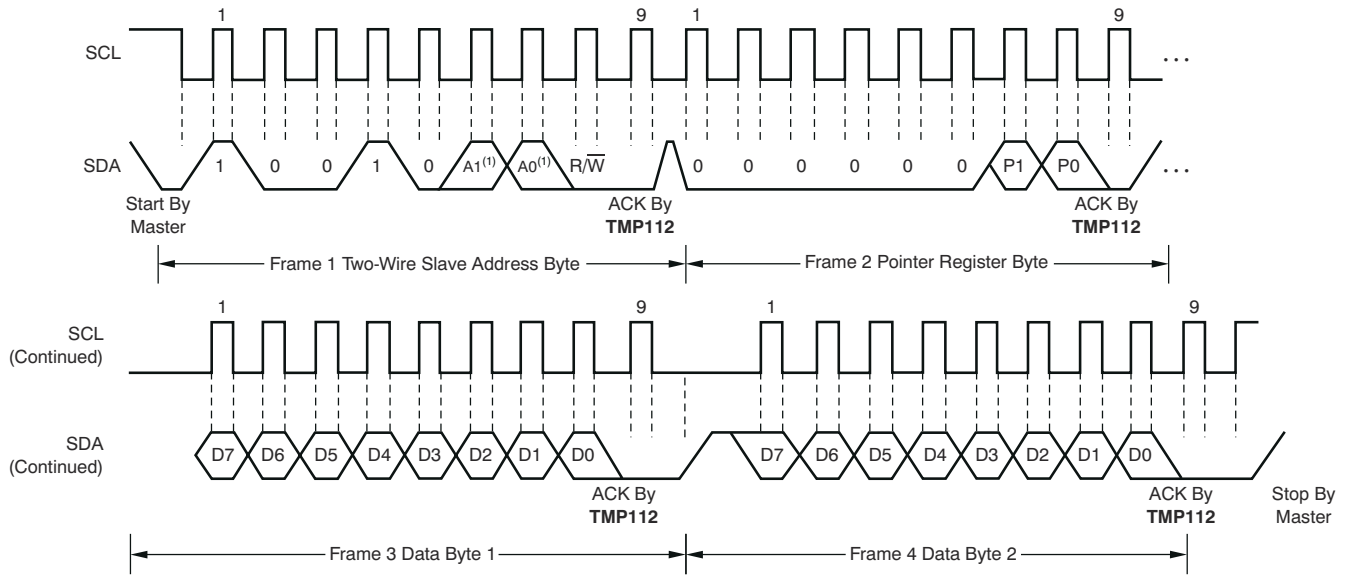
**Start Data Transfer:** A change in the state of the SDA line, from high to low, when the SCL line is high, defines a START condition. Each data transfer is initiated with a START condition.

**Stop Data Transfer:** A change in the state of the SDA line from low to high when the SCL line is high defines a STOP condition. Each data transfer is terminated with a repeated START or STOP condition.

**Data Transfer:** The number of data bytes transferred between a START and a STOP condition is not limited and is determined by the master device. The TMP112 family can also be used for single byte updates. To update only the MS byte, terminate the communication by issuing a START or STOP communication on the bus.

**Acknowledge:** Each receiving device, when addressed, is obliged to generate an Acknowledge bit. A device that acknowledges must pull down the SDA line during the Acknowledge clock pulse in such a way that the SDA line is stable low during the high period of the Acknowledge clock pulse. Setup and hold times must be taken into account. On a master receive, the termination of the data transfer can be signaled by the master generating a *Not-Acknowledge* ('1') on the last byte that has been transmitted by the slave.

#### 7.3.2.9.1 Two-Wire Timing Diagrams



NOTE: (1) The values of A0 and A1 are determined by the ADD0 pin.

**Figure 7-4. Two-Wire Timing Diagram for Write Word Format**

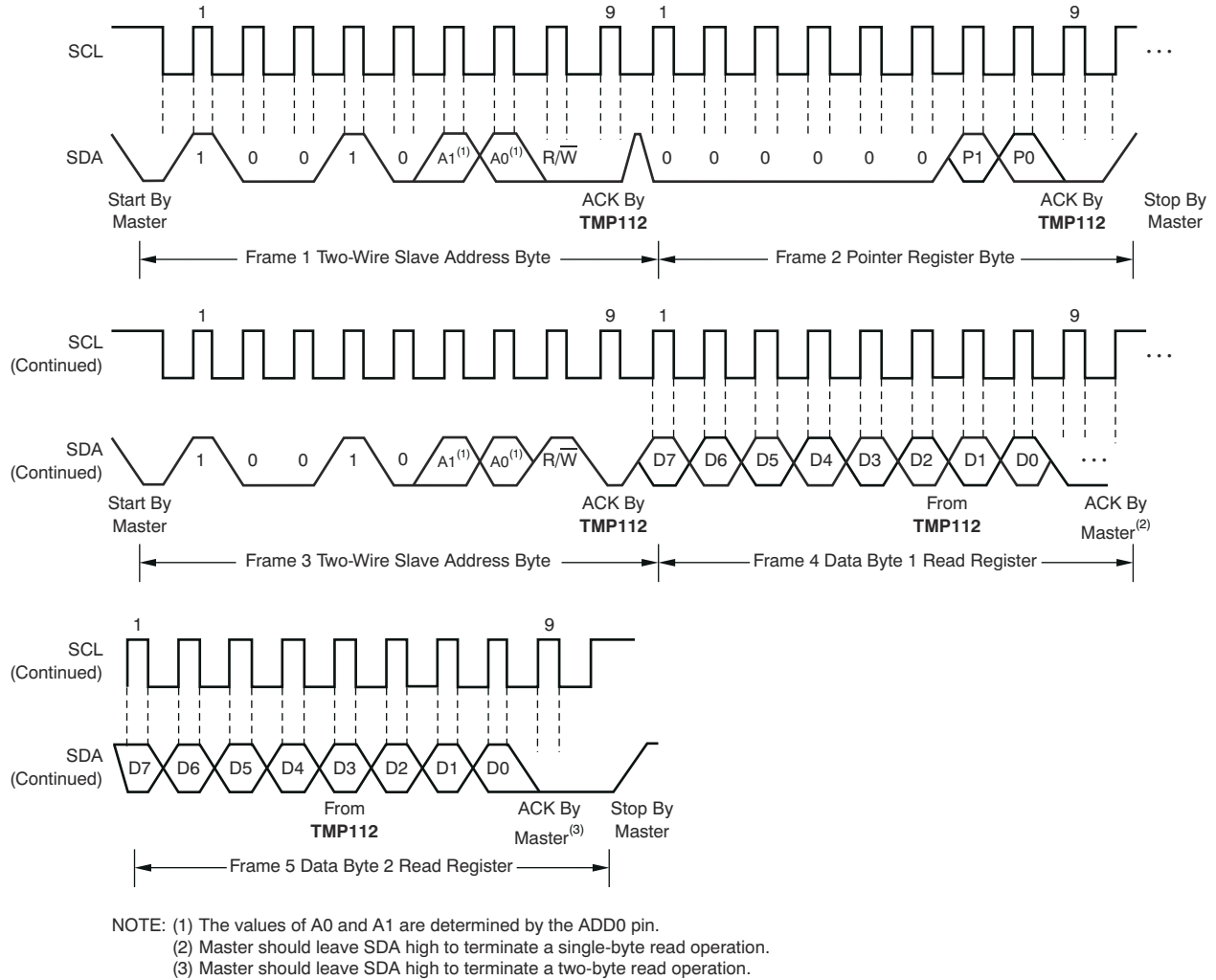


Figure 7-5. Two-Wire Timing Diagram for Read Word Format

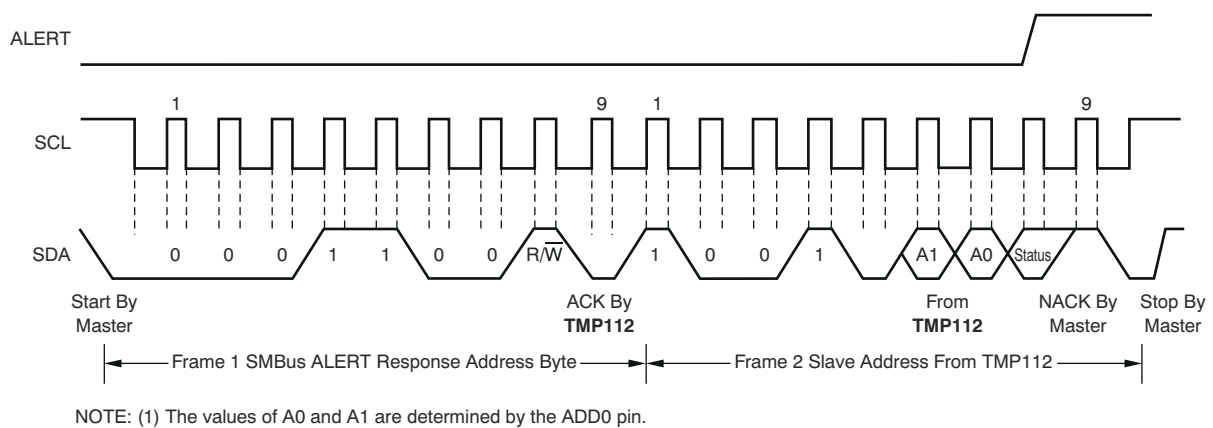


Figure 7-6. Timing Diagram for SMBus ALERT

## 7.4 Device Functional Modes

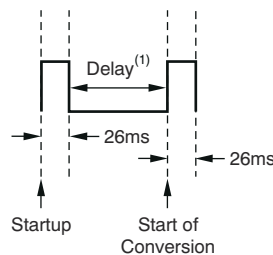
### 7.4.1 Continuous-Conversion Mode

The default mode of the TMP112 family is continuous conversion mode. During continuous-conversion mode, the ADC performs continuous temperature conversions and stores each results to the temperature register, overwriting the result from the previous conversion. The conversion rate bits, CR1 and CR0, configure the TMP112 family for conversion rates of 0.25 Hz, 1 Hz, 4 Hz, or 8 Hz. The default rate is 4 Hz. The TMP112 family has a typical conversion time of 26 ms for SOT563-6 package and 10 ms for X2SON-5 package. To achieve different conversion rates, the TMP112 family makes a conversion and then powers down and waits for the appropriate delay set by CR1 and CR0. [Table 7-5](#) lists the settings for CR1 and CR0.

**Table 7-5. Conversion Rate Settings**

CR1	CR0	CONVERSION RATE
0	0	0.25 Hz
0	1	1 Hz
1	0	4 Hz (default)
1	1	8 Hz

After a power-up or general-call reset, the TMP112 family immediately begins a conversion as shown in [Figure 7-7](#). The first result is available after 26 or 10 ms (typical). The active quiescent current during conversion is 40  $\mu$ A (typical at 27°C) for SOT563-6 package and 55  $\mu$ A (typical at 27°C) for X2SON-5 package. The quiescent current during delay is 2.2  $\mu$ A (typical at 27°C) for SOT563-6 package and 2.6  $\mu$ A (typical at 27°C) for X2SON-5 package.



**Figure 7-7. Conversion Start (SOT563-6 Package)**

### 7.4.2 Extended Mode (EM)

The extended mode bit configures the device for normal mode operation (EM = 0) or extended mode operation (EM = 1). In normal mode, the temperature register and the high and low limit registers use a 12-bit data format. Normal mode is used to make the TMP112 family compatible with the [TMP75](#) device.

Extended mode (EM = 1) allows measurement of temperatures above 128°C by configuring the temperature register and the high and low limit registers for 13-bit data format.

### 7.4.3 One-Shot/Conversion Ready Mode (OS)

The TMP112 family features a one-shot temperature-measurement mode. When the device is in shutdown mode, writing a 1 to the OS bit begins a single temperature conversion. During the conversion, the OS bit reads 0. The device returns to the SHUTDOWN state at the completion of the single conversion. After the conversion, the OS bit reads 1. This feature is useful for reducing power consumption in the TMP112 family when continuous temperature monitoring is not required.

As a result of the short conversion time, the TMP112 family can achieve a higher conversion rate. A single conversion typically occurs for 26 ms for SOT563-6 package and 10 ms for X2SON-5 package, and a read can occur in less than 20  $\mu$ s. When using one-shot mode, 30 or more conversions per second are possible.

### 7.4.4 Thermostat Mode (TM)

The thermostat mode bit indicates to the device whether to operate in comparator mode (TM = 0 ) or interrupt mode (TM = 1).

#### 7.4.4.1 Comparator Mode (TM = 0)

In Comparator mode (TM = 0), the Alert pin and status flag are activated when the temperature equals or exceeds the value in the  $T_{(HIGH)}$  register and remains active until the temperature falls below the value in the  $T_{(LOW)}$  register. For more information on the comparator mode, see the [Section 7.5.4](#) section.

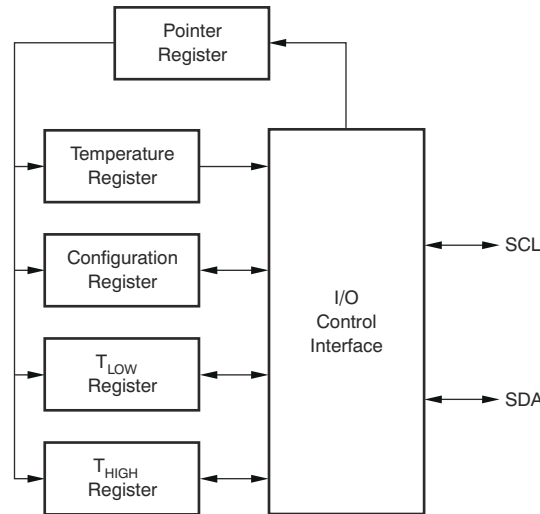
#### 7.4.4.2 Interrupt Mode (TM = 1)

In Interrupt mode (TM = 1), the Alert pin is activated when the temperature exceeds  $T_{(HIGH)}$  or goes below  $T_{(LOW)}$  registers. The Alert pin is cleared when the host controller reads the temperature register. For more information on the interrupt mode, see the [Section 7.5.4](#) section.

## 7.5 Programming

### 7.5.1 Pointer Register

[Figure 7-8](#) shows the internal register structure of the TMP112 family. The 8-bit Pointer Register of the device is used to address a given data register. The Pointer Register uses the two LSBs (see [Table 7-13](#)) to identify which of the data registers must respond to a read or write command. The power-up reset value of P1/P0 is '00'. By default, the TMP112 family reads the temperature on power-up.



**Figure 7-8. Internal Register Structure**

[Table 7-6](#) lists the pointer address of the registers available in the TMP112 family. [Table 7-7](#) lists the bits of the Pointer Register byte. During a write command, bytes P2 through P7 must always be 0.

**Table 7-6. Pointer Addresses**

P1	P0	REGISTER
0	0	Temperature Register (Read Only)
0	1	Configuration Register (Read/Write)
1	0	$T_{LOW}$ Register (Read/Write)
1	1	$T_{HIGH}$ Register (Read/Write)

**Table 7-7. Pointer Register Byte**

P7	P6	P5	P4	P3	P2	P1	P0
0	0	0	0	0	0	Register Bits	

### 7.5.2 Temperature Register

The Temperature Register of the TMP112 family is configured as a 12-bit read-only register (setting the EM bit to 0 in the configuration register; see the [Extended Mode](#) section), or as a 13-bit read-only register (setting the EM bit to 1 in the configuration register) that stores the output of the most recent conversion. Two bytes must be read to obtain data and are listed in [Table 7-8](#) and [Table 7-9](#). Byte 1 is the most significant byte (MSB), followed by byte 2, the least significant byte (LSB). The first 12 bits (13 bits in extended mode) are used to indicate temperature. The least significant byte does not have to be read if that information is not needed.

**Table 7-8. Byte 1 of Temperature Register**

**Note:** Extended mode 13-bit configuration shown in parentheses.

BYTE	D7	D6	D5	D4	D3	D2	D1	D0
1	T11	T10	T9	T8	T7	T6	T5	T4
	(T12)	(T11)	(T10)	(T9)	(T8)	(T7)	(T6)	(T5)

**Table 7-9. Byte 2 of Temperature Register**

**Note:** Extended mode 13-bit configuration shown in parentheses.

BYTE	D7	D6	D5	D4	D3	D2	D1	D0
2	T3	T2	T1	T0	0	0	0	0
	(T4)	(T3)	(T2)	(T1)	(T0)	(0)	(0)	(1)

### 7.5.3 Configuration Register

The Configuration Register is a 16-bit read/write register used to store bits that control the operational modes of the temperature sensor. Read/write operations are performed MSB first. [Table 7-10](#) lists the format and power-up and reset values of the configuration register. For compatibility, the first byte corresponds to the Configuration Register in the [TMP75](#) and [TMP275](#) devices. All registers are updated byte by byte.

**Table 7-10. Configuration and Power-Up/Reset Formats**

BYTE	D7	D6	D5	D4	D3	D2	D1	D0
1	OS	R1	R0	F1	F0	POL	TM	SD
	0	1	1	0	0	0	0	0
2	CR1	CR0	AL	EM	0	0	0	0
	1	0	1	0	0	0	0	0

#### 7.5.3.1 Shutdown Mode (SD)

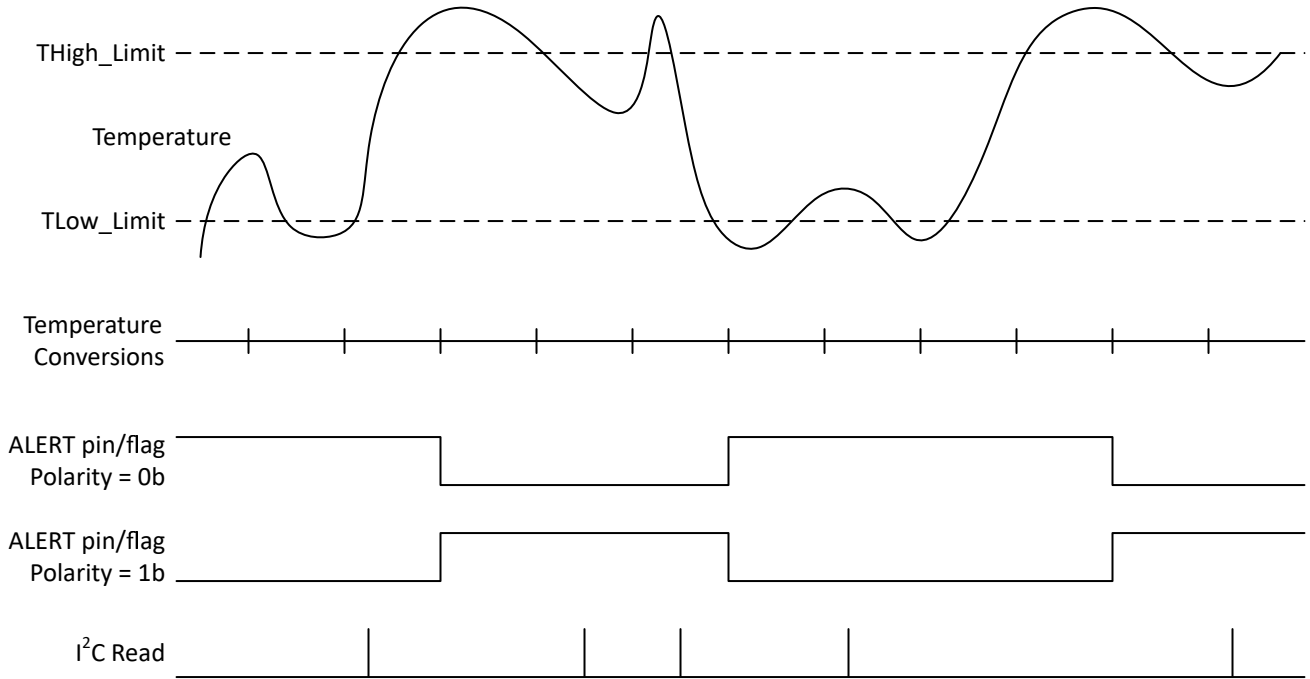
The Shutdown mode bit saves maximum power by shutting down all device circuitry other than the serial interface, reducing current consumption to typically less than 0.5  $\mu\text{A}$  for SOT563-6 package and 0.15  $\mu\text{A}$  for X2SON-5 package. Shutdown mode is enabled when the SD bit = 1; the device shuts down when current conversion is completed. When SD = 0, the device maintains a continuous conversion state.

#### 7.5.3.2 Thermostat Mode (TM)

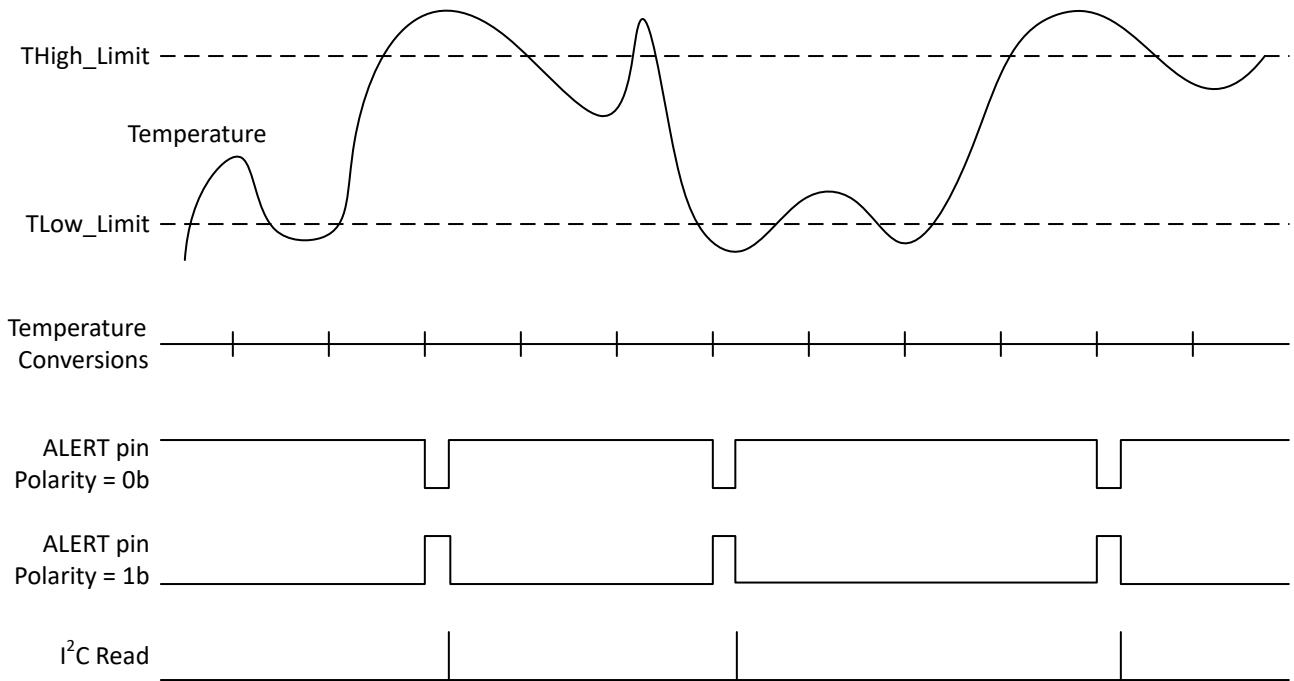
The Thermostat mode bit indicates to the device whether to operate in Comparator mode (TM = 0 shown in [Figure 7-9](#)) or Interrupt mode (TM = 1 shown in [Figure 7-10](#)). For more information on Comparator and Interrupt modes, see the [High- and Low-Limit Registers](#) section.

### 7.5.3.3 Polarity (POL)

The polarity bit allows the user to adjust the polarity of the ALERT pin/flag output. If the POL bit is set to 0 (default), the ALERT pin/flag becomes active low. When the POL bit is set to 1, the ALERT pin/flag becomes active high and the state of the ALERT pin/flag is inverted. The operation of the ALERT pin/flag in various modes is illustrated in [Figure 7-9](#) and [Figure 7-10](#).



**Figure 7-9. Comparator Mode**



**Figure 7-10. Interrupt Mode**

### 7.5.3.4 Fault Queue (F1/F0)

A fault condition exists when the measured temperature exceeds the user-defined limits set in the  $T_{HIGH}$  and  $T_{LOW}$  registers. Additionally, the number of fault conditions required to generate an alert, can be programmed using the fault queue. The fault queue is provided to prevent a false alert as a result of environmental noise. The fault queue requires consecutive fault measurements to trigger the alert function. [Table 7-11](#) lists the number of measured faults that can be programmed to trigger an alert condition in the device. For  $T_{HIGH}$  and  $T_{LOW}$  register format and byte order, see the [High- and Low-Limit Registers](#) section.

**Table 7-11. TMP112 family Fault Settings**

F1	F0	CONSECUTIVE FAULTS
0	0	1
0	1	2
1	0	4
1	1	6

### 7.5.3.5 Converter Resolution (R1 and R0)

The converter resolution bits, R1 and R0, are read-only bits. The TMP112 family converter resolution is set on start up to 11 which sets the temperature register to a 12-bit resolution.

### 7.5.3.6 One-Shot (OS)

When the device is in shutdown mode, writing a 1 to the OS bit begins a single temperature conversion. During the conversion, the OS bit reads 0. The device returns to the SHUTDOWN state at the completion of the single conversion. For more information on the one-shot conversion mode, see the [Section 7.4.3](#) section.

### 7.5.3.7 Extended Mode (EM)

The extended mode bit configures the device for normal mode operation (EM = 0) or extended mode operation (EM = 1). In normal mode, the temperature register and the high and low limit registers use a 12-bit data format. For more information on the extended mode, see the [Section 7.4.2](#) section.

### 7.5.3.8 Alert (AL)

The AL bit is a read-only function. Reading the AL bit provides information about the comparator mode status. The state of the POL bit inverts the polarity of data returned from the AL bit. When the POL bit equals 0, the AL bit reads as 1 until the temperature equals or exceeds  $T_{(HIGH)}$  for the programmed number of consecutive faults, causing the AL bit to read as 0. The AL bit continues to read as 0 until the temperature falls below  $T_{(LOW)}$  for the programmed number of consecutive faults, when the device again reads as 1. The status of the TM bit does not affect the operation of the AL bit.

## 7.5.4 High- and Low-Limit Register

The temperature limits are stored in the  $T_{(LOW)}$  and  $T_{(HIGH)}$  registers in the same format as the temperature result, and the values are compared to the temperature result on every conversion. The outcome of the comparison drives the behavior of the ALERT pin/flag, which operates as a comparator output or an interrupt, and is set by the TM bit in the configuration register.

In Comparator mode (TM = 0), the ALERT pin and status flag become active when the temperature equals or exceeds the value in the  $T_{(HIGH)}$  register and generates a consecutive number of faults according to fault bits F1 and F0. The ALERT pin and status flag remain active until the temperature falls below the indicated  $T_{(LOW)}$  value for the same number of faults.

In interrupt mode (TM = 1), the ALERT pin becomes active when the temperature equals or exceeds the value in  $T_{(HIGH)}$  for a consecutive number of fault conditions (as shown in [Table 7-11](#)). The ALERT pin remains active until a read operation of any register occurs, or the device successfully responds to the SMBus alert response address. The ALERT pin is also cleared if the device is placed in shutdown mode. When the ALERT pin is cleared, the pin becomes active again only when temperature falls below  $T_{(LOW)}$ , and remains active until cleared by a read operation of any register or a successful response to the SMBus alert response address.

When the ALERT pin is cleared, the above cycle repeats, with the ALERT pin becoming active when the temperature equals or exceeds  $T_{(HIGH)}$ . The ALERT pin can also be cleared by resetting the device with the general-call Reset command. This action also clears the state of the internal registers in the device, returning the device to comparator mode ( $TM = 0$ ).

Both operating modes are represented in [Figure 7-9](#) and [Figure 7-10](#). [Table 7-12](#) and [Table 7-13](#) list the format for the  $T_{HIGH}$  and  $T_{LOW}$  registers. The most significant byte is sent first, followed by the least significant byte. The power-up reset values for  $T_{(HIGH)}$  and  $T_{(LOW)}$  are:

- $T_{HIGH} = +80^{\circ}C$
- $T_{LOW} = +75^{\circ}C$

The format of the data for  $T_{HIGH}$  and  $T_{LOW}$  is the same as for the Temperature Register.

**Table 7-12. Bytes 1 and 2 of  $T_{HIGH}$  Register**

BYTE	D7	D6	D5	D4	D3	D2	D1	D0
1	H11	H10	H9	H8	H7	H6	H5	H4
	(H12)	(H11)	(H10)	(H9)	(H8)	(H7)	(H6)	(H5)
BYTE	D7	D6	D5	D4	D3	D2	D1	D0
2	H3	H2	H1	H0	0	0	0	0
	(H4)	(H3)	(H2)	(H1)	(H0)	(0)	(0)	(0)

**Table 7-13. Bytes 1 and 2 of  $T_{LOW}$  Register**

BYTE	D7	D6	D5	D4	D3	D2	D1	D0
1	L11	L10	L9	L8	L7	L6	L5	L4
	(L12)	(L11)	(L10)	(L9)	(L8)	(L7)	(L6)	(L5)
BYTE	D7	D6	D5	D4	D3	D2	D1	D0
2	L3	L2	L1	L0	0	0	0	0
	(L4)	(L3)	(L2)	(L1)	(L0)	(0)	(0)	(0)

## 8 Application and Implementation

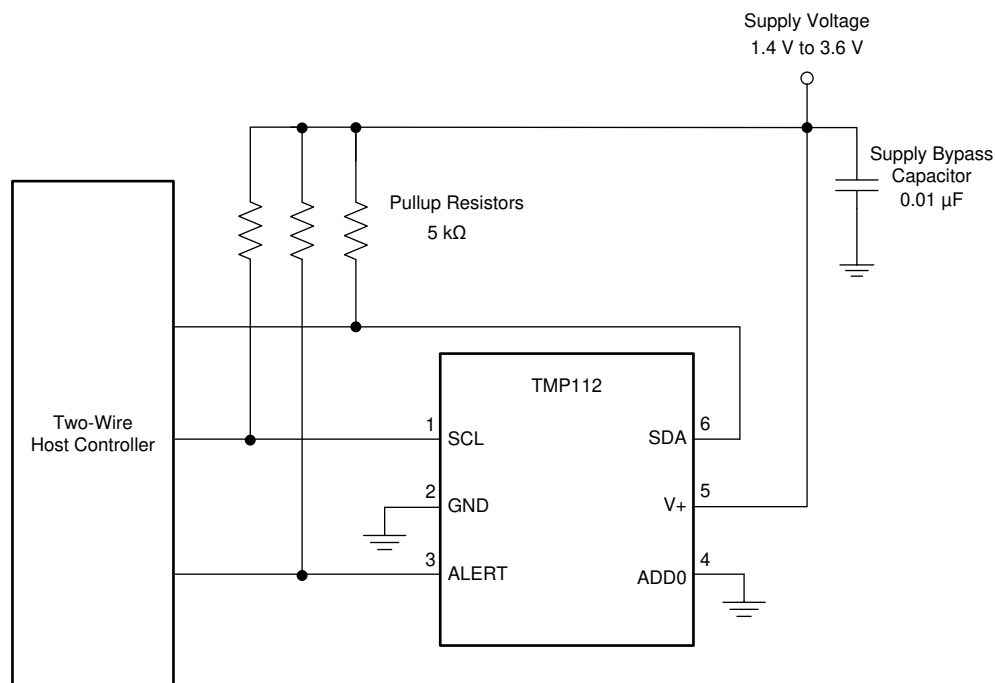
### Note

Information in the following applications sections is not part of the TI component specification, and TI does not warrant its accuracy or completeness. TI's customers are responsible for determining suitability of components for their purposes. Customers should validate and test their design implementation to confirm system functionality.

### 8.1 Application Information

The TMP112 family is used to measure the PCB temperature of the board location where the device is mounted. The programmable address options allow up to four locations on the board to be monitored on a single serial bus.

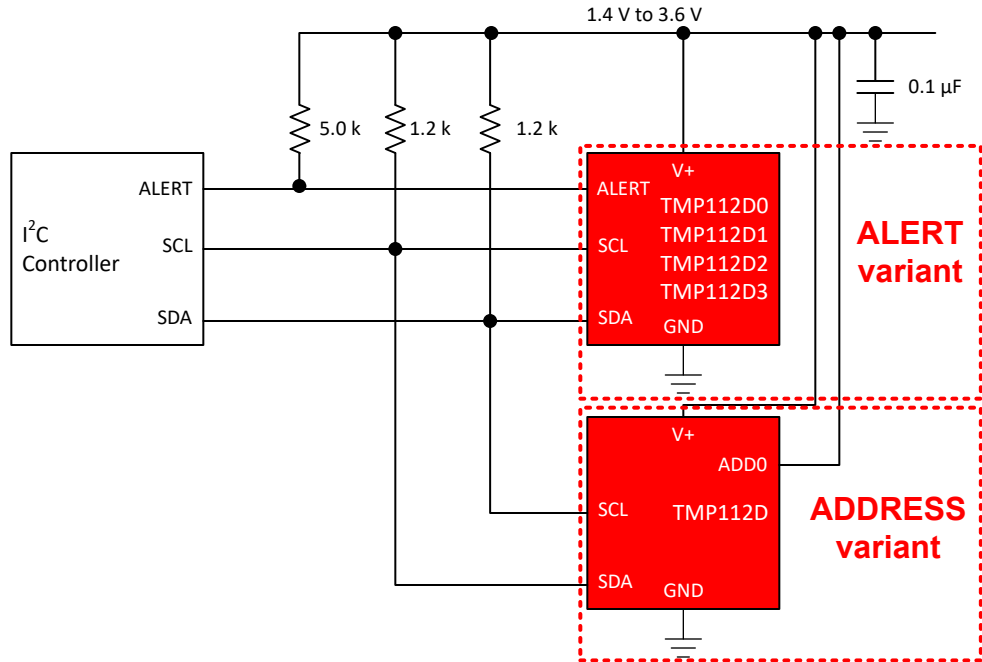
### 8.2 Typical Application



### Note

The SCL, SDA, and ALERT pins require pullup resistors.

**Figure 8-1. Typical Connections (SOT563-6 Package)**



**Figure 8-2. Typical Connections (X2SON-5 Package)**

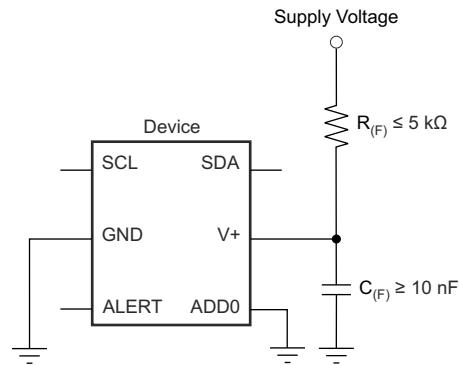
### 8.2.1 Design Requirements

The TMP112 family requires pullup resistors on the SCL, SDA, and ALERT pins. The recommended value for the pullup resistors is 1.2 k $\Omega$  and 5 k $\Omega$ . In some applications the pullup resistor can be lower or higher than 5 k $\Omega$  but must not exceed 3 mA of current on any of those pins. A 0.01- $\mu$ F (for SOT563-6 package) or 0.1- $\mu$ F (for X2SON-5 package) bypass capacitor on the supply is recommended as shown in [Figure 8-1](#) and [Figure 8-2](#). The SCL and SDA lines can be pulled up to a supply that is equal to or higher than V+ through the pullup resistors. To configure one of four different addresses on the bus, connect the ADD0 pin to either the GND, V+, SDA, or SCL pin. The TMP112Dx also provides four different address options when only ALERT pin is used.

### 8.2.2 Detailed Design Procedure

Place the device in close proximity to the heat source that must be monitored, with a proper layout for good thermal coupling. This placement verifies that temperature changes are captured within the shortest possible time interval. To maintain accuracy in applications that require air or surface temperature measurement, take care to isolate the package and leads from ambient air temperature. A thermally-conductive adhesive is helpful in achieving accurate surface temperature measurement.

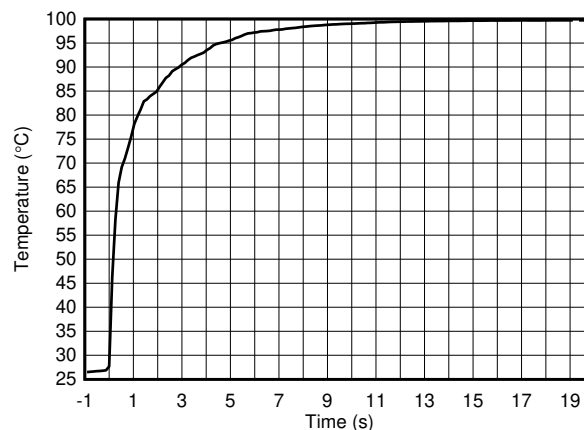
The TMP112 family is a very low-power device and generates very low noise on the supply bus. Applying an RC filter to the V+ pin of the TMP112 family can further reduce any noise that the device can propagate to other components.  $R_{(F)}$  in [Figure 8-3](#) must be less than 5 k $\Omega$  and  $C_{(F)}$  must be greater than 10 nF.



**Figure 8-3. Noise Reduction Techniques (for SOT563-6 package as an example)**

### 8.2.3 Application Curves

Figure 8-4 shows the step response of the TMP112 family (for SOT563-6 package) to a submersion in an oil bath of 100°C from room temperature (27°C). The time-constant, or the time for the output to reach 63% of the input step, is 0.8s (for SOT563-6 package) and TBDs (for X2SON-5 package). The time-constant result depends on the printed-circuit board (PCB) that the TMP112 family is mounted. For this test, the TMP112 family was soldered to a two-layer PCB that measured 0.375 inches × 0.437 inches.



**Figure 8-4. Temperature Step Response (for SOT563-6 package)**

### 8.2.4 Power Supply Recommendations

The TMP112 family operates with power supply in the range of 1.4 to 3.6 V. The device is optimized for operation at 3.3-V supply but can measure temperature accurately in the full supply range.

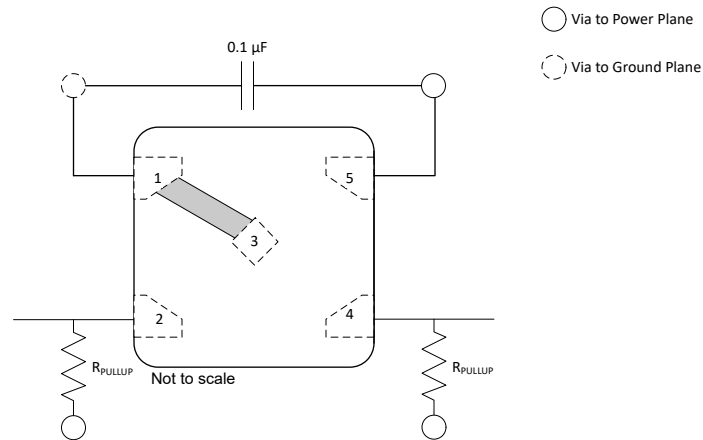
A power-supply bypass capacitor is required for proper operation. Place this capacitor as close as possible to the supply and ground pins of the device. A typical value for this supply bypass capacitor is 0.01  $\mu$ F (for SOT563-6 package) and 0.1  $\mu$ F (for X2SON-5 package). Applications with noisy or high-impedance power supplies can require additional decoupling capacitors to reject power-supply noise.

## 8.3 Layout

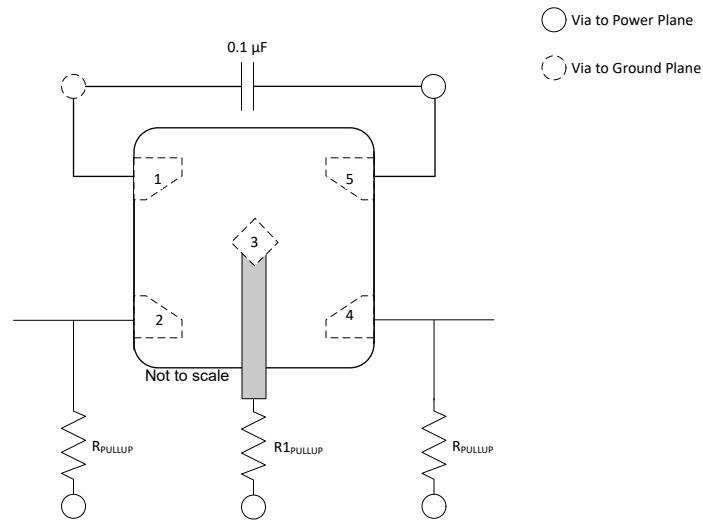
### 8.3.1 Layout Guidelines

Place the power-supply bypass capacitor as close as possible to the supply and ground pins. The recommended value of this bypass capacitor is 0.01  $\mu$ F (for SOT563-6 package) and 0.1  $\mu$ F (for X2SON-5 package). Additional decoupling capacitance can be added to compensate for noisy or high-impedance power supplies. Pull up the open-drain output pins (SDA, SCL) through 2-k $\Omega$  or 1.2-k $\Omega$  pullup resistors. However, using a minimal SDA and ALERT pins pull-up current is recommended to prevent self-heating and temperature accuracy reduction.

For TMP112Dx device, where the 5<sup>th</sup> pin is ADD0, the pin can easily be connected to one of the 4 edge pins for setting the device address as shown in [Figure 8-5](#). For devices where the 5<sup>th</sup> pin is ALERT, a 4 mil trace can be routed between pins 1 and 5 or pins 2 and 4 as shown in [Figure 8-6](#).

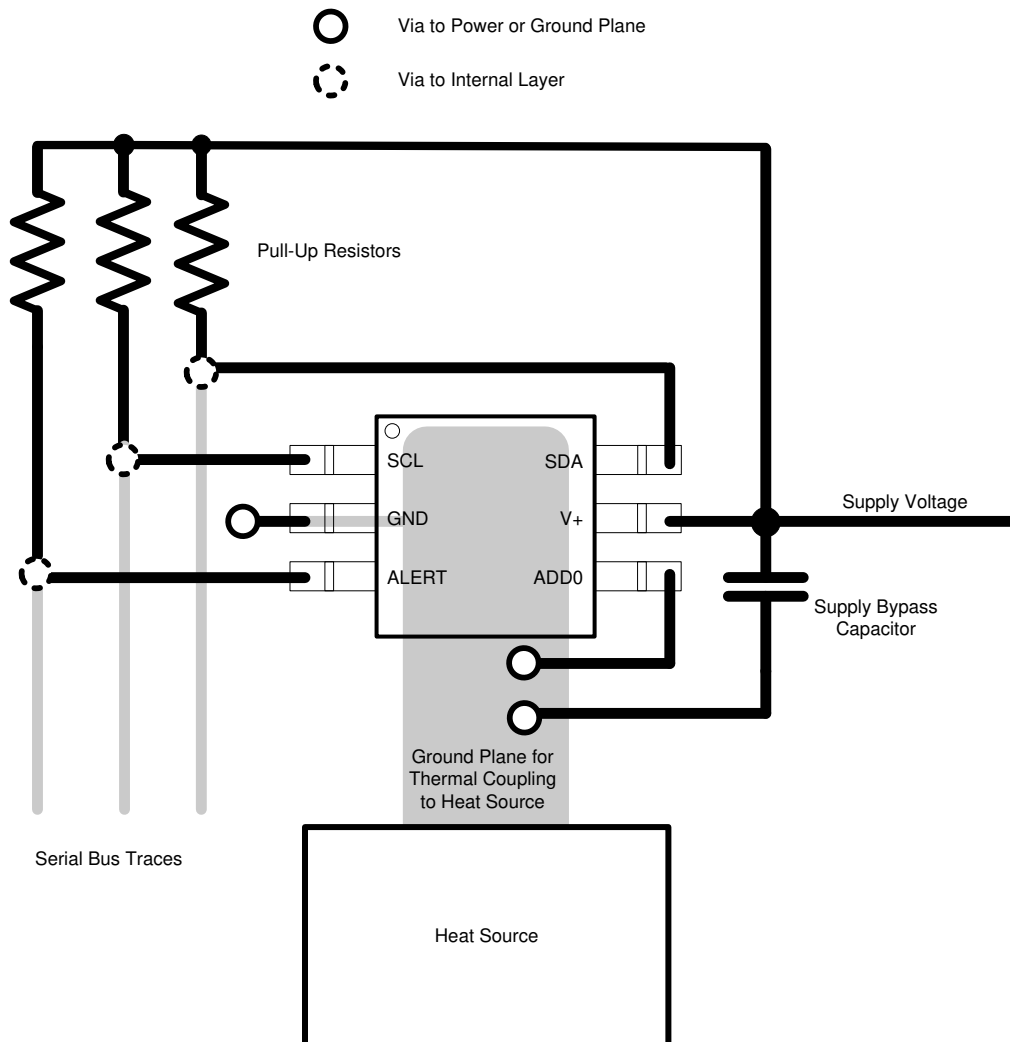


**Figure 8-5. ADD0 Pin Layout Example**



**Figure 8-6. ALERT Pin Layout Example**

### 8.3.2 Layout Example



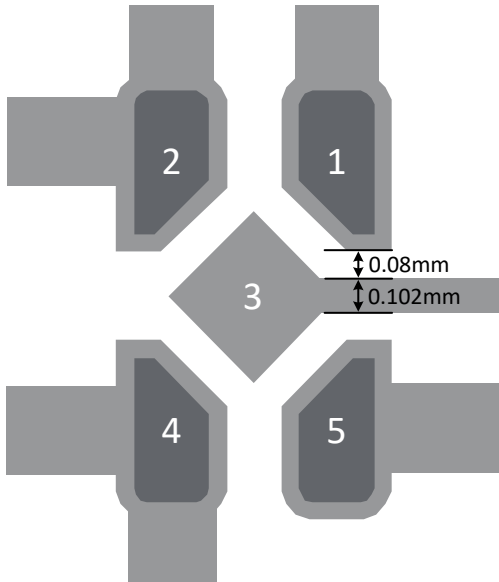
**Figure 8-7. Layout Example (SOT563-6 package)**

There are special considerations that need to be taken for the TMP112 X2SON package. These considerations are due to the center pad being electrically connected to either address or alert (depending on the orderables shown in [Address and Alert Variant Device Target Address](#)) and because of the dimensions of the package and the pads. With the address option, the center pad can be directly connected with a trace on the same layer to the desired pin of the device as shown in [Figure 8-5](#).

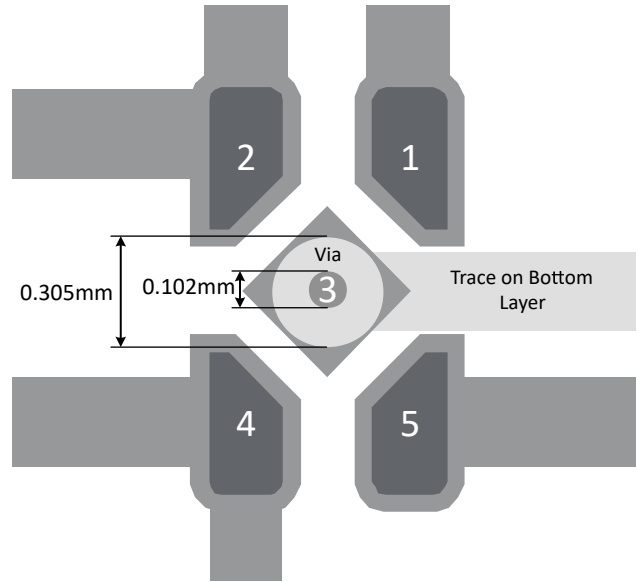
When using the ALERT pin of the device, this signal can be either routed out in between the pads or on a different layer using a via within the center pad as shown in [Figure 8-6](#). Both of these methods have constraints that must be considered as explained below. Ultimately, choosing one of these methods depends on the specifications of the board manufacturing process:

- **Routing in between pads** introduces trace clearance and trace width limitations. As the maximum space between pads is 0.26 mm (10.2 mil), assuming a trace width of 0.1 mm (4 mil) limits the minimum clearance to 0.08 mm (3.15 mil).
- **Routing on a different layer using a via** has specific benefits to the user application. For instance, minimum trace clearance and trace width are higher but require a via on the center pad with specific dimensions. The via diameter must be less than 0.305 mm (13.78 mil) to keep the via smaller than the center pad and a minimum drill diameter of 0.1 mm (4 mil) can be assumed to avoid manufacturing issues. With this

scenario, a minimum annular ring width specification of 0.125mm (5 mil) is required: Anullar Ring Width (mm)  
= (0.305-0.1)/2.



**Figure 8-8. X2SON-5 (DPW) Package Center Pin Layout Option 1**



**Figure 8-9. X2SON-5 (DPW) Package Center Pin Layout Option 2**

## 9 Device and Documentation Support

### 9.1 Documentation Support

#### 9.1.1 Related Documentation

For related documentation see the following:

- Texas Instruments, [TMP102 Low-Power Digital Temperature Sensor With SMBus and Two-Wire Serial Interface in SOT563](#), data sheet
- Texas Instruments, [TMPx75 Temperature Sensor With I<sup>2</sup>C and SMBus Interface in Industry Standard LM75 Form Factor and Pinout](#), data sheet
- Texas Instruments, [TMP275 ±0.5°C Temperature Sensor With I<sup>2</sup>C and SMBus Interface in Industry Standard LM75 Form Factor and Pinout](#), data sheet
- Texas Instruments, [Ultralow Power Multi-Sensor Data Logger With NFC Interface](#), design guide
- Texas Instruments, [Capacitive-Based Human Proximity Detection for System Wake-Up & Interrupt](#), design guide
- Texas Instruments, [Designing and Manufacturing with TI's X2SON Packages](#), design guide

#### 9.2 Receiving Notification of Documentation Updates

To receive notification of documentation updates, navigate to the device product folder on [ti.com](#). Click on *Notifications* to register and receive a weekly digest of any product information that has changed. For change details, review the revision history included in any revised document.

#### 9.3 Support Resources

[TI E2E™ support forums](#) are an engineer's go-to source for fast, verified answers and design help — straight from the experts. Search existing answers or ask your own question to get the quick design help you need.

Linked content is provided "AS IS" by the respective contributors. They do not constitute TI specifications and do not necessarily reflect TI's views; see TI's [Terms of Use](#).

#### 9.4 Trademarks

TI E2E™ is a trademark of Texas Instruments.

All trademarks are the property of their respective owners.

#### 9.5 Electrostatic Discharge Caution



This integrated circuit can be damaged by ESD. Texas Instruments recommends that all integrated circuits be handled with appropriate precautions. Failure to observe proper handling and installation procedures can cause damage.

ESD damage can range from subtle performance degradation to complete device failure. Precision integrated circuits may be more susceptible to damage because very small parametric changes could cause the device not to meet its published specifications.

#### 9.6 Glossary

##### [TI Glossary](#)

This glossary lists and explains terms, acronyms, and definitions.

## 10 Revision History

NOTE: Page numbers for previous revisions may differ from page numbers in the current version.

<b>Changes from Revision I (December 2018) to Revision J (February 2024)</b>	<b>Page</b>
• Updated the numbering format for tables, figures, and cross-references throughout the document.....	1
• Added X2SON (DPW) package (TMP112Dx) and related information throughout the document .....	1
• Changed reporting quiescent current from previous Maximum values to Typical values in the <i>Features</i> section .....	1
• Added <i>Device Comparison</i> section .....	3
• Added Output current ( $\pm 10\text{mA}$ ) to <i>Absolute Maximum Ratings</i> section.....	5
• Changed DRL package <i>Thermal Information</i> section.....	5
• Added DPW package to <i>Thermal Information</i> section.....	5
• Added Thermal Mass to <i>Thermal Information</i> section.....	5
• Added TMP112Dx (DPW package) information to <i>Electrical Characteristics</i> .....	6
• Changed “Timeout time” in description to “Timeout (SCL=GND or SDA=GND)” .....	6
• Added the average quiescent current for “Serial bus inactive, CR1 = 0, CR0 = 1” to the DRL package information in the <i>Electrical Characteristics</i> .....	6
• Added Fast Mode Plus column to the <i>Timing Requirements</i> table.....	8
• Moved the "Two-Wire Timing Diagram" figure from the <i>Two-Wire Timing Diagrams</i> section to the <i>Specifications</i> section .....	8
• Added TMP112Dx and TMP110 information to the <i>Advantages of TMP112 Family Versus TMP102 and TMP110</i> table .....	14
• Added 0.0625 and -0.0625 row to Temperature column of <i>12-Bit Temperature Data Format</i> and <i>13-Bit Temperature Data Format</i> tables in the <i>Digital Temperature Output</i> section.....	15
• Updated <i>Address and Alert Variant Device Target Address</i> table in the <i>Serial Bus Address</i> section to include the new package (TMP112Dx) .....	17
• Changed “Output Transfer Function Diagrams” figure to “Comparator Mode” and “Interrupt Mode” figures for more clarity.....	25
• Added <i>Layout Guidelines</i> and <i>Layout Example</i> for new package.....	30

<b>Changes from Revision H (October 2018) to Revision I (December 2018)</b>	<b>Page</b>
• Deleted <i>Absolute Maximum Ratings</i> for output voltage and replaced with pin level information.....	5
• Changed input voltage maximum to voltage maximum for SCL, ADD0 and SDA pins.....	5
• Added voltage at ALERT pin <i>Absolute Maximum Ratings</i> .....	5

## 11 Mechanical, Packaging, and Orderable Information

The following pages include mechanical, packaging, and orderable information. This information is the most current data available for the designated devices. This data is subject to change without notice and revision of this document. For browser-based versions of this data sheet, refer to the left-hand navigation.

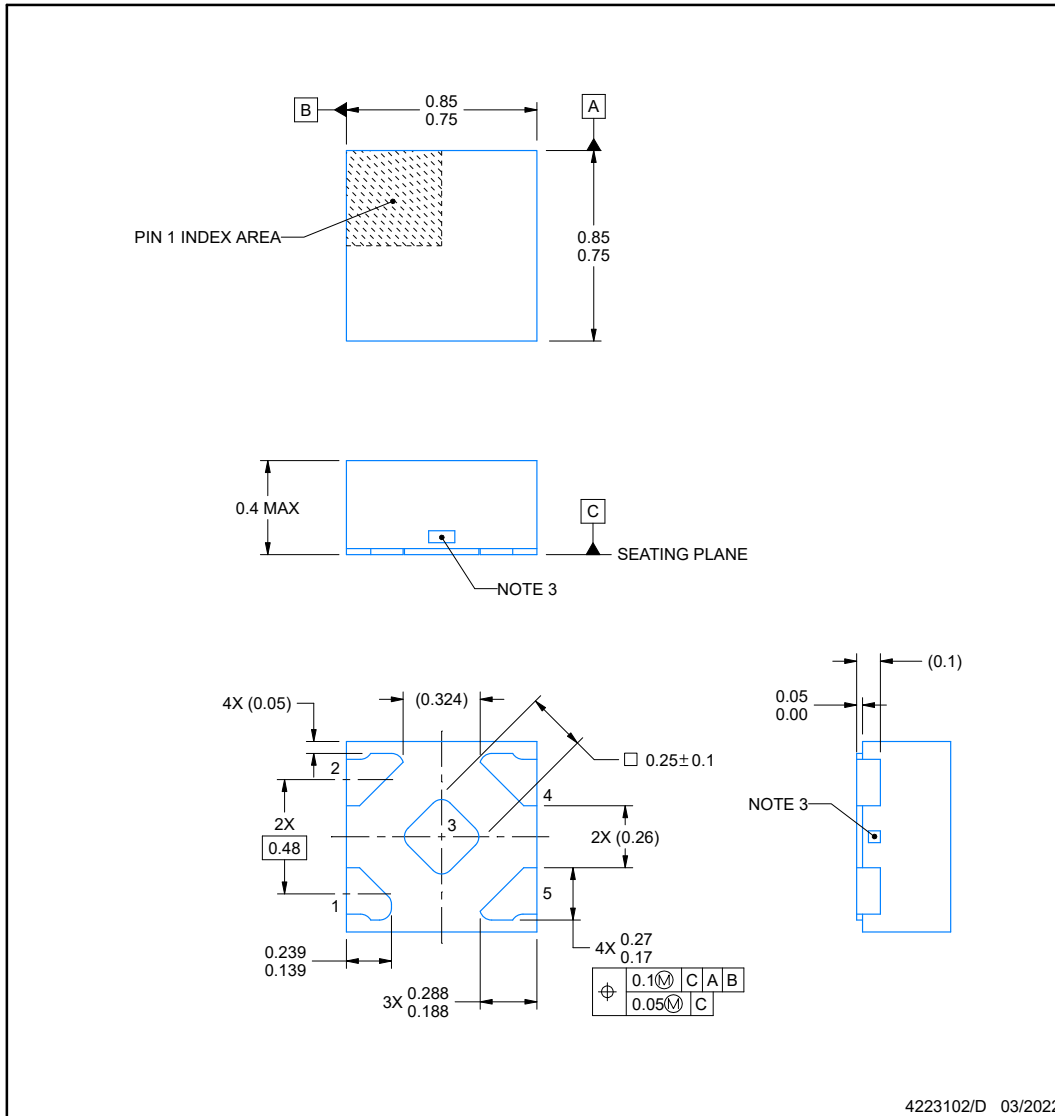


**DPW0005A**

**PACKAGE OUTLINE**

**X2SON - 0.4 mm max height**

PLASTIC SMALL OUTLINE - NO LEAD



NOTES:

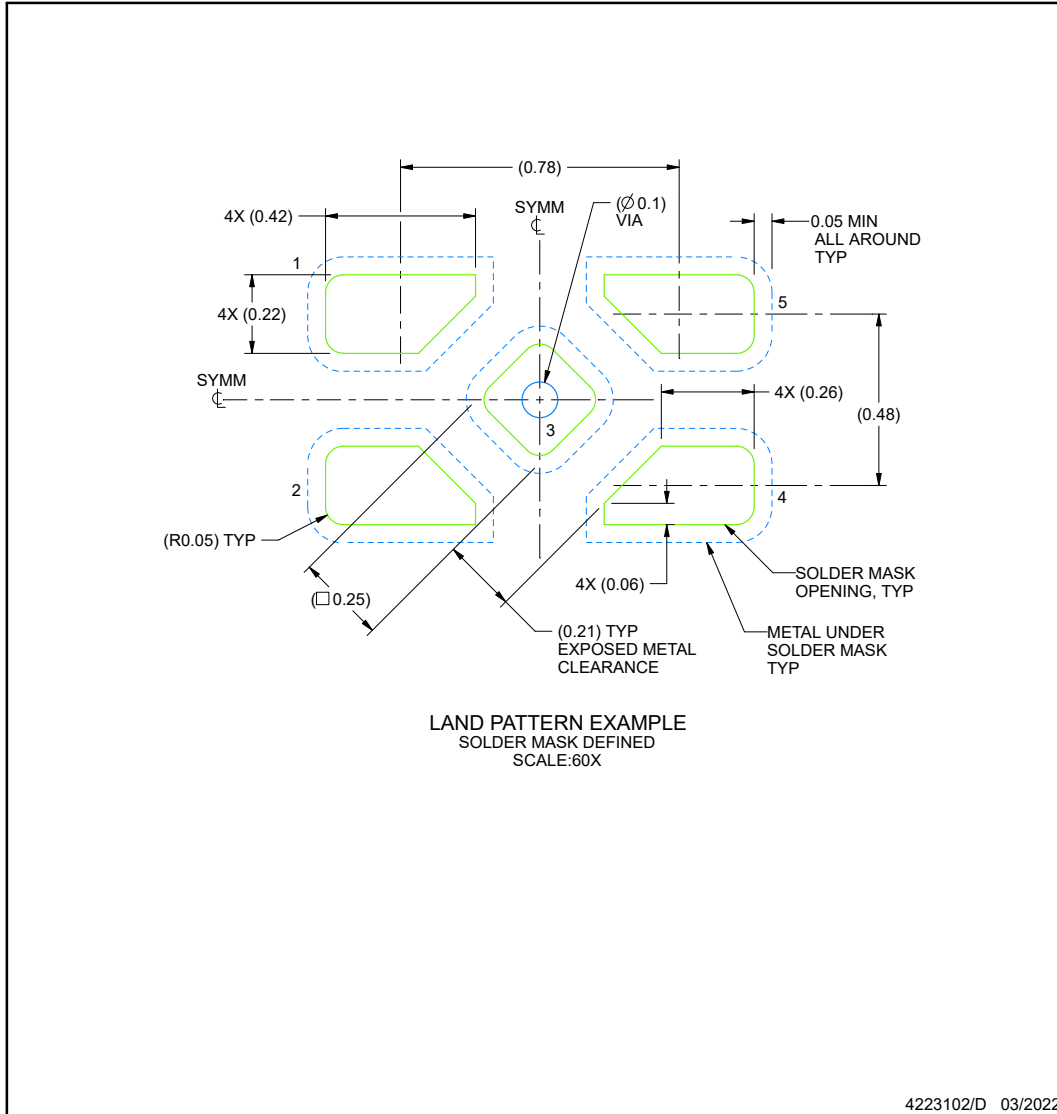
1. All linear dimensions are in millimeters. Any dimensions in parenthesis are for reference only. Dimensioning and tolerancing per ASME Y14.5M.
2. This drawing is subject to change without notice.
3. The size and shape of this feature may vary.

**EXAMPLE BOARD LAYOUT**

**DPW0005A**

**X2SON - 0.4 mm max height**

PLASTIC SMALL OUTLINE - NO LEAD



NOTES: (continued)

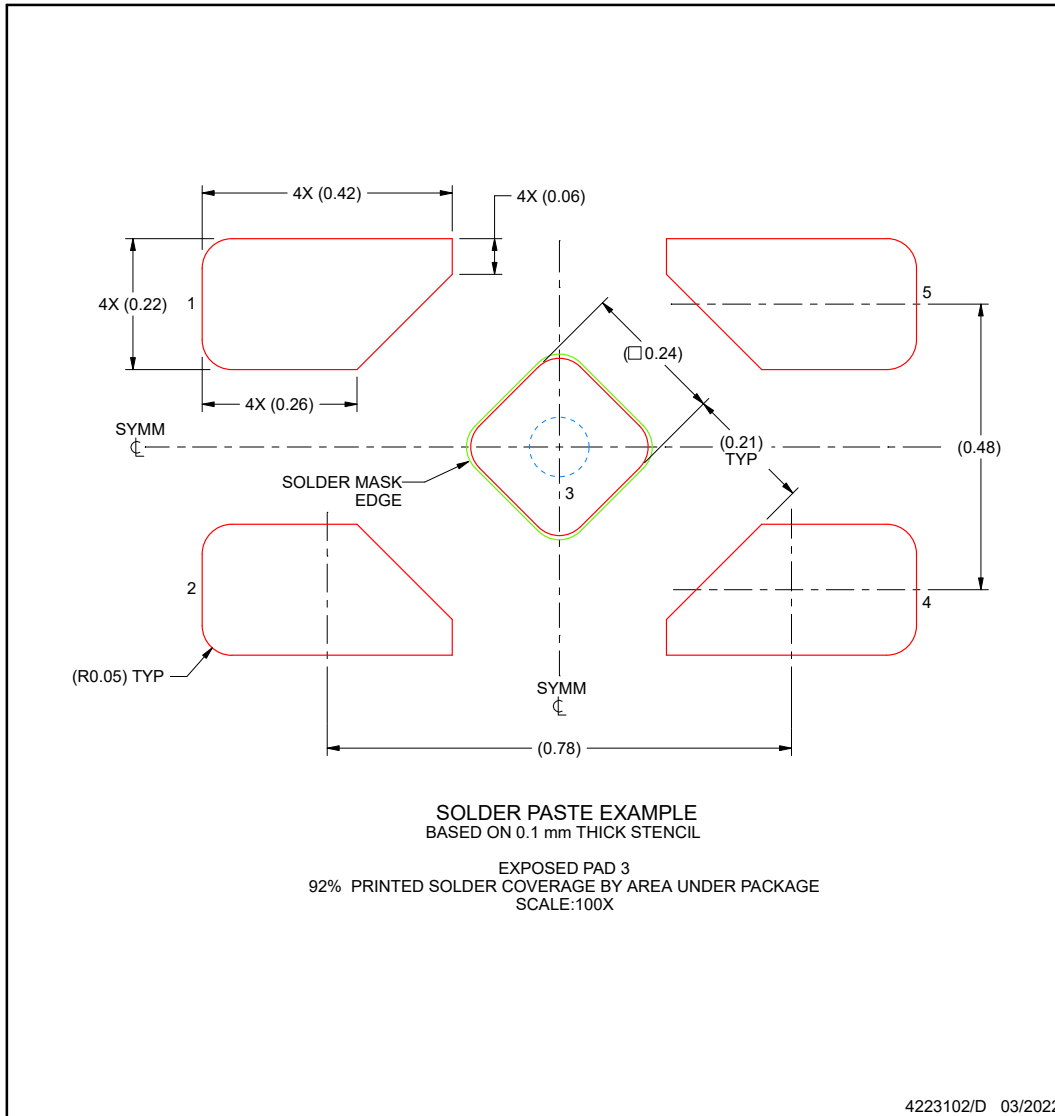
4. This package is designed to be soldered to a thermal pad on the board. For more information, refer to QFN/SON PCB application note in literature No. SLUA271 ([www.ti.com/lit/sluea271](http://www.ti.com/lit/sluea271)).

**EXAMPLE STENCIL DESIGN**

**DPW0005A**

**X2SON - 0.4 mm max height**

PLASTIC SMALL OUTLINE - NO LEAD



NOTES: (continued)

- 5. Laser cutting apertures with trapezoidal walls and rounded corners may offer better paste release. IPC-7525 may have alternate design recommendations.

**PACKAGING INFORMATION**

Orderable Device	Status (1)	Package Type	Package Drawing	Pins	Package Qty	Eco Plan (2)	Lead finish/ Ball material (6)	MSL Peak Temp (3)	Op Temp (°C)	Device Marking (4/5)	Samples
PTMP112D0IDPWR	ACTIVE	X2SON	DPW	5	3000	TBD	Call TI	Call TI	-40 to 125		Samples
TMP112AIDRLR	ACTIVE	SOT-5X3	DRL	6	4000	RoHS & Green	NIPDAU   NIPDAUAG	Level-1-260C-UNLIM	-40 to 125	OBS	Samples
TMP112BIDRLR	ACTIVE	SOT-5X3	DRL	6	4000	RoHS & Green	NIPDAUAG	Level-1-260C-UNLIM	-40 to 125	1B8	Samples
TMP112NAIDRLR	ACTIVE	SOT-5X3	DRL	6	4000	RoHS & Green	NIPDAUAG	Level-1-260C-UNLIM	-40 to 125	1AB	Samples

(1) The marketing status values are defined as follows:

**ACTIVE:** Product device recommended for new designs.

**LIFEBUY:** TI has announced that the device will be discontinued, and a lifetime-buy period is in effect.

**NRND:** Not recommended for new designs. Device is in production to support existing customers, but TI does not recommend using this part in a new design.

**PREVIEW:** Device has been announced but is not in production. Samples may or may not be available.

**OBSOLETE:** TI has discontinued the production of the device.

(2) **RoHS:** TI defines "RoHS" to mean semiconductor products that are compliant with the current EU RoHS requirements for all 10 RoHS substances, including the requirement that RoHS substance do not exceed 0.1% by weight in homogeneous materials. Where designed to be soldered at high temperatures, "RoHS" products are suitable for use in specified lead-free processes. TI may reference these types of products as "Pb-Free".

**RoHS Exempt:** TI defines "RoHS Exempt" to mean products that contain lead but are compliant with EU RoHS pursuant to a specific EU RoHS exemption.

**Green:** TI defines "Green" to mean the content of Chlorine (Cl) and Bromine (Br) based flame retardants meet JS709B low halogen requirements of <=1000ppm threshold. Antimony trioxide based flame retardants must also meet the <=1000ppm threshold requirement.

(3) MSL, Peak Temp. - The Moisture Sensitivity Level rating according to the JEDEC industry standard classifications, and peak solder temperature.

(4) There may be additional marking, which relates to the logo, the lot trace code information, or the environmental category on the device.

(5) Multiple Device Markings will be inside parentheses. Only one Device Marking contained in parentheses and separated by a "-" will appear on a device. If a line is indented then it is a continuation of the previous line and the two combined represent the entire Device Marking for that device.

(6) Lead finish/Ball material - Orderable Devices may have multiple material finish options. Finish options are separated by a vertical ruled line. Lead finish/Ball material values may wrap to two lines if the finish value exceeds the maximum column width.

**Important Information and Disclaimer:**The information provided on this page represents TI's knowledge and belief as of the date that it is provided. TI bases its knowledge and belief on information provided by third parties, and makes no representation or warranty as to the accuracy of such information. Efforts are underway to better integrate information from third parties. TI has taken and

continues to take reasonable steps to provide representative and accurate information but may not have conducted destructive testing or chemical analysis on incoming materials and chemicals. TI and TI suppliers consider certain information to be proprietary, and thus CAS numbers and other limited information may not be available for release.

In no event shall TI's liability arising out of such information exceed the total purchase price of the TI part(s) at issue in this document sold by TI to Customer on an annual basis.

**OTHER QUALIFIED VERSIONS OF TMP112 :**

- Automotive : [TMP112-Q1](#)

NOTE: Qualified Version Definitions:

- Automotive - Q100 devices qualified for high-reliability automotive applications targeting zero defects

**TAPE AND REEL INFORMATION**

**QUADRANT ASSIGNMENTS FOR PIN 1 ORIENTATION IN TAPE**


\*All dimensions are nominal

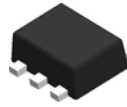
Device	Package Type	Package Drawing	Pins	SPQ	Reel Diameter (mm)	Reel Width W1 (mm)	A0 (mm)	B0 (mm)	K0 (mm)	P1 (mm)	W (mm)	Pin1 Quadrant
TMP112AIDRLR	SOT-5X3	DRL	6	4000	180.0	8.4	1.98	1.78	0.69	4.0	8.0	Q3
TMP112AIDRLR	SOT-5X3	DRL	6	4000	180.0	8.4	2.0	1.8	0.75	4.0	8.0	Q3
TMP112BIDRLR	SOT-5X3	DRL	6	4000	180.0	8.4	1.98	1.78	0.69	4.0	8.0	Q3
TMP112NAIDRLR	SOT-5X3	DRL	6	4000	180.0	8.4	1.98	1.78	0.69	4.0	8.0	Q3

**TAPE AND REEL BOX DIMENSIONS**


\*All dimensions are nominal

Device	Package Type	Package Drawing	Pins	SPQ	Length (mm)	Width (mm)	Height (mm)
TMP112AIDRLR	SOT-5X3	DRL	6	4000	202.0	201.0	28.0
TMP112AIDRLR	SOT-5X3	DRL	6	4000	210.0	185.0	35.0
TMP112BIDRLR	SOT-5X3	DRL	6	4000	183.0	183.0	20.0
TMP112NAIDRLR	SOT-5X3	DRL	6	4000	183.0	183.0	20.0

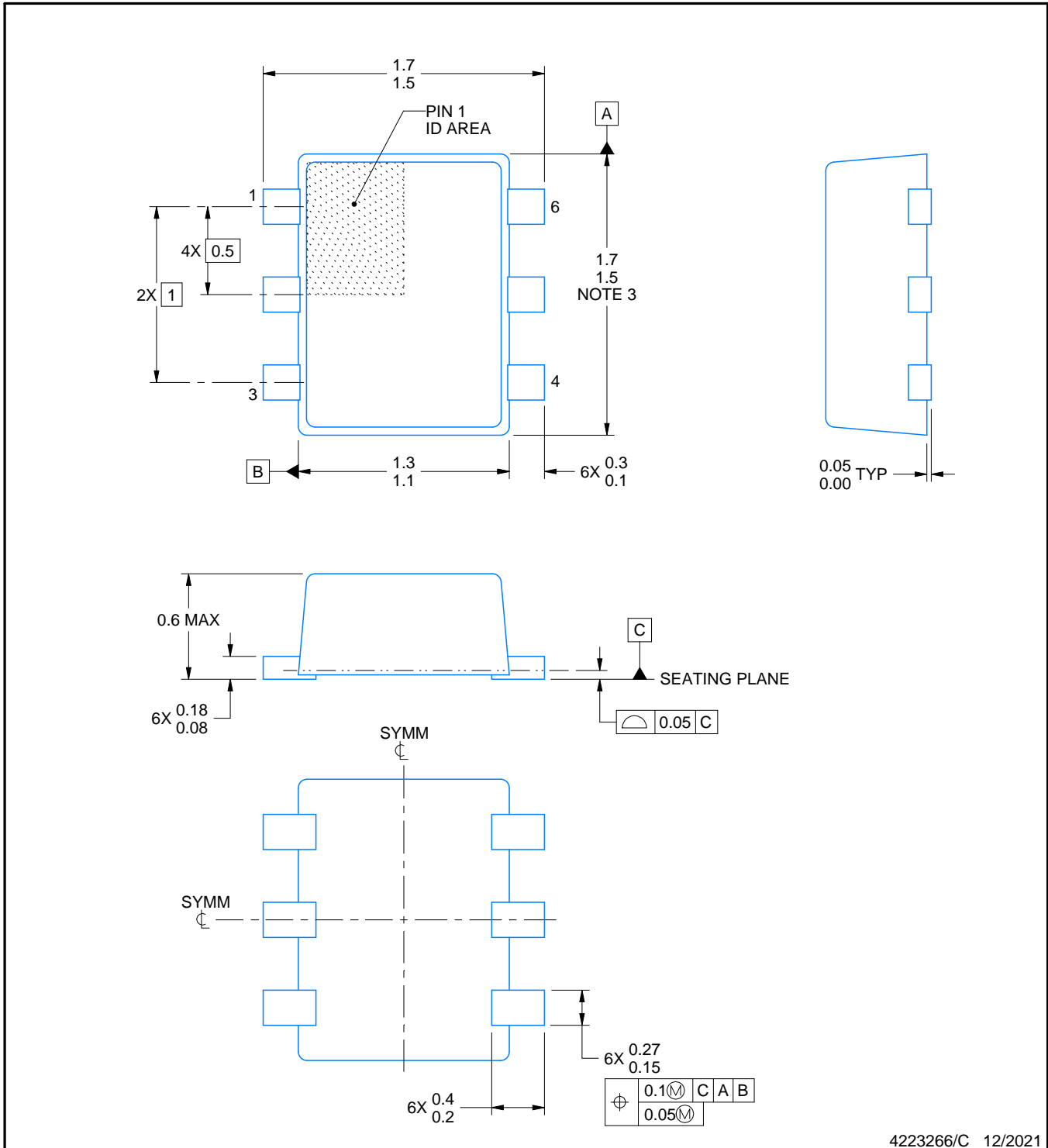
# DRL0006A



# PACKAGE OUTLINE

## SOT - 0.6 mm max height

PLASTIC SMALL OUTLINE



4223266/C 12/2021

### NOTES:

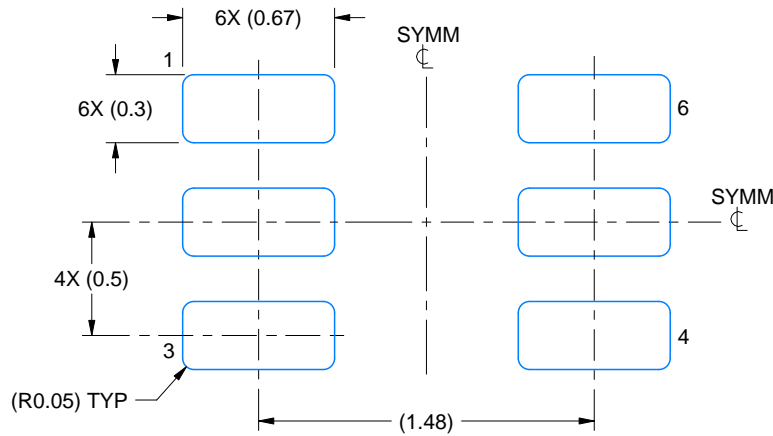
1. All linear dimensions are in millimeters. Any dimensions in parenthesis are for reference only. Dimensioning and tolerancing per ASME Y14.5M.
2. This drawing is subject to change without notice.
3. This dimension does not include mold flash, protrusions, or gate burrs. Mold flash, protrusions, or gate burrs shall not exceed 0.15 mm per side.
4. Reference JEDEC registration MO-293 Variation UAAD

# EXAMPLE BOARD LAYOUT

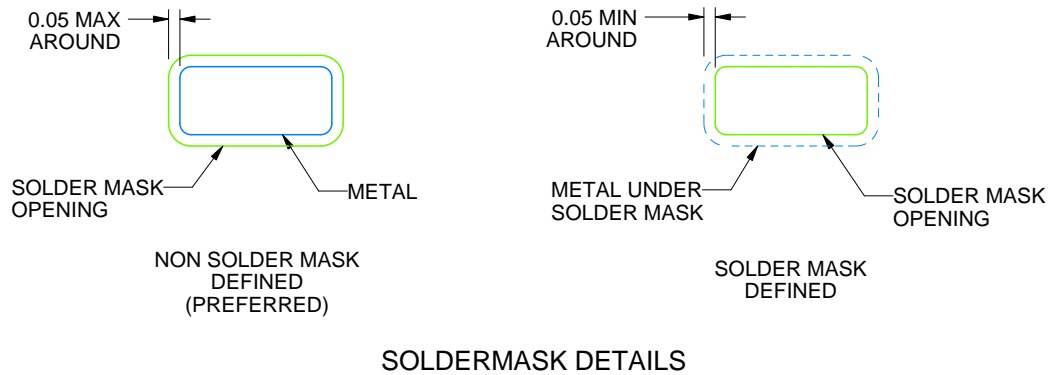
DRL0006A

SOT - 0.6 mm max height

PLASTIC SMALL OUTLINE



LAND PATTERN EXAMPLE  
SCALE:30X



SOLDERMASK DETAILS

4223266/C 12/2021

NOTES: (continued)

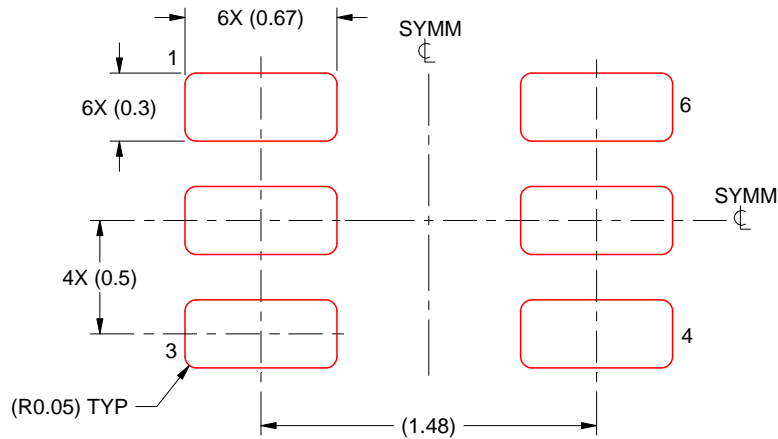
5. Publication IPC-7351 may have alternate designs.
6. Solder mask tolerances between and around signal pads can vary based on board fabrication site.
7. Land pattern design aligns to IPC-610, Bottom Termination Component (BTC) solder joint inspection criteria.

# EXAMPLE STENCIL DESIGN

DRL0006A

SOT - 0.6 mm max height

PLASTIC SMALL OUTLINE



SOLDER PASTE EXAMPLE  
BASED ON 0.1 mm THICK STENCIL  
SCALE:30X

4223266/C 12/2021

NOTES: (continued)

8. Laser cutting apertures with trapezoidal walls and rounded corners may offer better paste release. IPC-7525 may have alternate design recommendations.
9. Board assembly site may have different recommendations for stencil design.

## GENERIC PACKAGE VIEW

DPW 5

X2SON - 0.4 mm max height

PLASTIC SMALL OUTLINE - NO LEAD



Images above are just a representation of the package family, actual package may vary.  
Refer to the product data sheet for package details.

4211218-3/D

## IMPORTANT NOTICE AND DISCLAIMER

TI PROVIDES TECHNICAL AND RELIABILITY DATA (INCLUDING DATA SHEETS), DESIGN RESOURCES (INCLUDING REFERENCE DESIGNS), APPLICATION OR OTHER DESIGN ADVICE, WEB TOOLS, SAFETY INFORMATION, AND OTHER RESOURCES "AS IS" AND WITH ALL FAULTS, AND DISCLAIMS ALL WARRANTIES, EXPRESS AND IMPLIED, INCLUDING WITHOUT LIMITATION ANY IMPLIED WARRANTIES OF MERCHANTABILITY, FITNESS FOR A PARTICULAR PURPOSE OR NON-INFRINGEMENT OF THIRD PARTY INTELLECTUAL PROPERTY RIGHTS.

These resources are intended for skilled developers designing with TI products. You are solely responsible for (1) selecting the appropriate TI products for your application, (2) designing, validating and testing your application, and (3) ensuring your application meets applicable standards, and any other safety, security, regulatory or other requirements.

These resources are subject to change without notice. TI grants you permission to use these resources only for development of an application that uses the TI products described in the resource. Other reproduction and display of these resources is prohibited. No license is granted to any other TI intellectual property right or to any third party intellectual property right. TI disclaims responsibility for, and you will fully indemnify TI and its representatives against, any claims, damages, costs, losses, and liabilities arising out of your use of these resources.

TI's products are provided subject to [TI's Terms of Sale](#) or other applicable terms available either on [ti.com](https://www.ti.com) or provided in conjunction with such TI products. TI's provision of these resources does not expand or otherwise alter TI's applicable warranties or warranty disclaimers for TI products.

TI objects to and rejects any additional or different terms you may have proposed.

Mailing Address: Texas Instruments, Post Office Box 655303, Dallas, Texas 75265  
Copyright © 2024, Texas Instruments Incorporated

## Looking for pricing, stock, or lifecycle information?

Click below to explore more details on WIN SOURCE:

 [View TMP112AIDRLR on WIN SOURCE](#)

 [Texas Instruments](#) Information

## Optimize Your Supply Chain with WIN SOURCE Solutions

-  Global Sourcing Solution
-  Obsolete Management
-  Cost Control Management
-  Shortage Management
-  Alternative Solution
-  Excess Inventory Management