



**THE DATASHEET OF
TMP103FYFFR**



TMP103 Low-Power, Digital Temperature Sensor With Two-Wire Interface in WCSP

1 Features

- Multiple Device Access (MDA):
 - Global Read/Write Operations
- I²C™ and SMBus™-Compatible Interface
- Resolution: 8 Bits
- Accuracy: ±1°C Typical (–10°C to 100°C)
- Low Quiescent Current:
 - 3-μA Active I_Q at 0.25 Hz
 - 1-μA Shutdown
- Supply Range: 1.4 V to 3.6 V
- Digital Output
- 4-Ball WCSP (DSBGA) Package

2 Applications

- Handsets
- Notebooks
- SSDs
- Servers
- Telecom
- Set Top Boxes
- Low Power Environmental
- Sensors

3 Description

The TMP103 is a digital output temperature sensor in a four-ball wafer chip-scale package (WCSP). The TMP103 is capable of reading temperatures to a resolution of 1°C.

The TMP103 features a two-wire interface that is compatible with both I²C and SMBus interfaces. In addition, the interface supports multiple device access (MDA) commands that allow the master to communicate with multiple devices on the bus simultaneously, eliminating the need to send individual commands to each TMP103 on the bus.

Up to eight TMP103s can be tied together in parallel and easily read by the host. The TMP103 is especially suitable for space-constrained, power-sensitive applications with multiple temperature measurement zones that must be monitored.

The TMP103 is specified for operation over a temperature range of –40°C to 125°C.

Device Information⁽¹⁾

PART NUMBER	PACKAGE	BODY SIZE (NOM)
TMP103	DSBGA (4)	0.76 mm × 0.76 mm

(1) For all available packages, see the orderable addendum at the end of the data sheet.

Typical Application Diagram

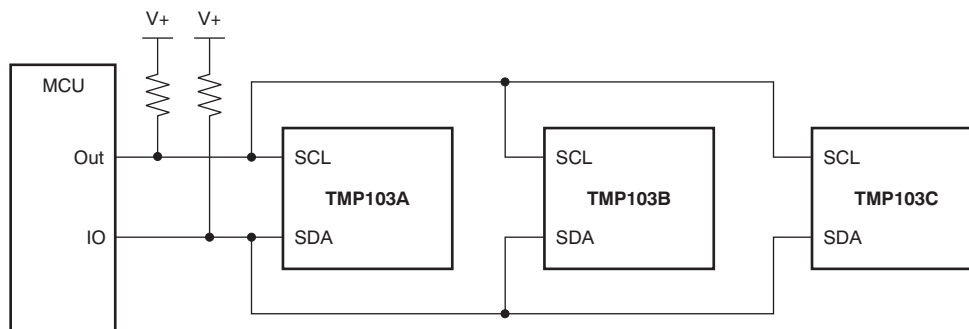

Table of Contents

1 Features 1 2 Applications 1 3 Description 1 4 Revision History 2 5 Pin Configuration and Functions 3 6 Specifications 3 6.1 Absolute Maximum Ratings 3 6.2 ESD Ratings..... 3 6.3 Recommended Operating Conditions 3 6.4 Thermal Information 4 6.5 Electrical Characteristics..... 4 6.6 Timing Requirements 5 6.7 Typical Characteristics 9 7 Detailed Description 10 7.1 Overview 10 7.2 Functional Block Diagram 10 7.3 Feature Description..... 11	7.4 Device Functional Modes..... 11 7.5 Programming..... 11 7.6 Register Maps 16 8 Application and Implementation 19 8.1 Application Information..... 19 8.2 Typical Application 19 9 Power Supply Recommendations 21 10 Layout 21 10.1 Layout Guidelines 21 10.2 Layout Example 21 11 Device and Documentation Support 22 11.1 Receiving Notification of Documentation Updates 22 11.2 Community Resources..... 22 11.3 Trademarks 22 11.4 Electrostatic Discharge Caution..... 22 11.5 Glossary 22 12 Mechanical, Packaging, and Orderable Information 22
---	--

4 Revision History

NOTE: Page numbers for previous revisions may differ from page numbers in the current version.

Changes from Revision C (October 2018) to Revision D	Page
<ul style="list-style-type: none"> • Changed input voltage maximum value in the Absolute Maximum Ratings table from: $(V^+) + 0.5$) and ≤ 4 to $(V^+) + 0.3$) and ≤ 4 3 	3
Changes from Revision A (March 2011) to Revision B	Page
<ul style="list-style-type: none"> • Added <i>ESD Ratings</i> table, <i>Feature Description</i> section, <i>Device Functional Modes</i> section, <i>Application and Implementation</i> section, <i>Power Supply Recommendations</i> section, <i>Layout</i> section, <i>Device and Documentation Support</i> section, and <i>Mechanical, Packaging, and Orderable Information</i> section 1 • Added SSDs, Servers, Telecom, Set Top Boxes, Low Power Environmental, and Sensors to <i>Applications</i> section..... 1 	1
Changes from Original (February 2011) to Revision A	Page
<ul style="list-style-type: none"> • Changed Package-Lead from WCSP-4 to DSBGA-4 in <i>Device Information</i> table 1 	1

5 Pin Configuration and Functions

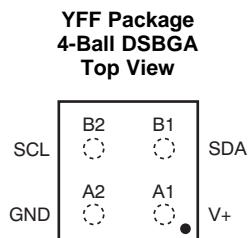

Pin Functions

PIN		I/O	DESCRIPTION
NO.	NAME		
A1	V ⁺	I	Supply voltage
A2	GND	I	Ground
B1	SDA	I/O	Input/output data pin
B2	SCL	I	Input clock pin

6 Specifications

6.1 Absolute Maximum Ratings

over operating free-air temperature range (unless otherwise noted)⁽¹⁾

		MIN	MAX	UNIT
V ⁺	Supply voltage		4	V
	Voltage at SCL and SDA	-0.3	((V ⁺ + 0.3) and ≤ 4	V
	Operating temperature	-55	150	°C
T _J	Junction temperature		150	°C
T _{stg}	Storage temperature	-60	150	°C

(1) Stresses beyond those listed under *Absolute Maximum Ratings* may cause permanent damage to the device. These are stress ratings only, which do not imply functional operation of the device at these or any other conditions beyond those indicated under *Recommended Operating Conditions*. Exposure to absolute-maximum-rated conditions for extended periods may affect device reliability.

6.2 ESD Ratings

		VALUE	UNIT
V _(ESD)	Electrostatic discharge	Human body model (HBM), per ANSI/ESDA/JEDEC JS-001, all pins ⁽¹⁾	±2000
		Charged device model (CDM), per JEDEC specification JESD22-C101, all pins ⁽²⁾	±1000
		Machine model (MM)	±200

(1) JEDEC document JEP155 states that 500-V HBM allows safe manufacturing with a standard ESD control process.

(2) JEDEC document JEP157 states that 250-V CDM allows safe manufacturing with a standard ESD control process.

6.3 Recommended Operating Conditions

over operating free-air temperature range (unless otherwise noted)

		MIN	MAX	UNIT
V ⁺	Supply voltage	1.4	3.6	V
T _A	Operating free-air temperature	-40	125	°C

6.4 Thermal Information

THERMAL METRIC ⁽¹⁾		TMP103	
		YFF (DSBGA)	UNIT
		4 BALLS	
R _{θJA}	Junction-to-ambient thermal resistance	160	°C/W
R _{θJC(top)}	Junction-to-case (top) thermal resistance	75	°C/W
R _{θJB}	Junction-to-board thermal resistance	76	°C/W
ψ _{JT}	Junction-to-top characterization parameter	3	°C/W
ψ _{JB}	Junction-to-board characterization parameter	74	°C/W

(1) For more information about traditional and new thermal metrics, see the [Semiconductor and IC Package Thermal Metrics](#) application report.

6.5 Electrical Characteristics

at T_A = 25°C and V⁺ = 1.4 V to 3.6 V (unless otherwise noted)

PARAMETER	TEST CONDITIONS	MIN	TYP	MAX	UNIT
TEMPERATURE INPUT					
Range		-40		125	°C
Accuracy (temperature error)	-10°C to 100°C, V ⁺ = 1.8 V	-2	0	2	°C
	-40°C to 125°C, V ⁺ = 1.8 V vs supply	-3	±1	3	
Resolution		-0.5	±0.2	0.5	°C/V
			1		°C
DIGITAL INPUT/OUTPUT					
V _{IH} — Input logic levels		0.7 (V ⁺)		V ⁺	V
V _{IL}		-0.5		0.3 (V ⁺)	
I _{IN} Input current	0 < V _{IN} < (V ⁺) + 0.3 V			1	μA
V _{OL} SDA Output logic levels	V ⁺ > 2 V, I _{OL} = 2 mA	0		0.4	V
	V ⁺ < 2 V, I _{OL} = 2 mA	0		0.2 (V ⁺)	
Resolution			8		Bit
Conversion time			26	35	ms
Conversion modes	CR1 = 0, CR0 = 0 (default)		0.25		Conv/s
	CR1 = 0, CR0 = 1		1		
	CR1 = 1, CR0 = 0		4		
	CR1 = 1, CR0 = 1		8		
Timeout time			30	40	ms
POWER SUPPLY					
Operating supply range		1.4		3.6	V
I _Q Quiescent current	Serial bus inactive, CR1 = 0, CR0 = 0 (default), V ⁺ = 1.8 V		1.5	3	μA
	Serial bus active, SCL frequency = 400 kHz		15		
	Serial bus active, SCL frequency = 3.4 MHz		85		
I _{SD} Shutdown current	Serial bus inactive, V ⁺ = 1.8 V		0.5	1	μA
	Serial bus active, SCL frequency = 400 kHz		10		
	Serial bus active, SCL frequency = 3.4 MHz		80		
TEMPERATURE					
Specified range		-40		125	°C
Operating range		-55		150	°C

6.6 Timing Requirements

 See ⁽¹⁾

		FAST MODE		HIGH-SPEED MODE		UNIT
		MIN	MAX	MIN	MAX	
$f_{(SCL)}$	SCL operating frequency, $V_S > 1.7\text{ V}$	0.001	0.4	0.001	3.4	MHz
$f_{(SCL)}$	SCL operating frequency, $V_S < 1.7\text{ V}$	0.001	0.4	0.001	2.75	MHz
$t_{(BUF)}$	Bus free time between STOP and START condition	600		160		ns
$t_{(HDSTA)}$	Hold time after repeated START condition. After this period, the first clock is generated.	100		100		ns
$t_{(SUSTA)}$	Repeated START condition setup time	100		100		ns
$t_{(SUSTO)}$	STOP condition setup Time	100		100		ns
$t_{(HDDAT)}$	Data hold time	20	400	10	125	ns
$t_{(SUDAT)}$	Data setup time	100		10		ns
$t_{(LOW)}$	SCL clock low period, $V_S > 1.7\text{ V}$	1300		160		ns
$t_{(LOW)}$	SCL clock low period, $V_S < 1.7\text{ V}$	1300		200		ns
$t_{(HIGH)}$	SCL clock high period	600		60		ns
t_F	Clock/data fall time		300			ns
t_R	Clock/data rise time		300		160	ns
t_R	Clock/data rise time for $SCLK \leq 100\text{ kHz}$		1000			ns

(1) Values based on a statistical analysis of a one-time sample of devices. Minimum and maximum values are not guaranteed and not production tested.

The TMP103 is two-wire and SMBus compatible. [Figure 1](#) to [Figure 5](#) describe the various operations on the TMP103. Parameters for [Figure 1](#) are defined in [Timing Requirements](#). Bus definitions are:

Bus Idle: Both SDA and SCL lines remain high.

Start Data Transfer: A change in the state of the SDA line, from high to low, while the SCL line is high, defines a START condition. Each data transfer is initiated with a START condition.

Stop Data Transfer: A change in the state of the SDA line from low to high while the SCL line is high defines a STOP condition. Each data transfer is terminated with a repeated START or STOP condition.

Data Transfer: The number of data bytes transferred between a START and a STOP condition is not limited and is determined by the master device.

Acknowledge: Each receiving device, when addressed, is obliged to generate an Acknowledge bit. A device that acknowledges must pull down the SDA line during the Acknowledge clock pulse in such a way that the SDA line is stable low during the high period of the Acknowledge clock pulse. Setup and hold times must be taken into account. On a master receive, the termination of the data transfer can be signaled by the master generating a *Not-Acknowledge* (1) on the last byte transmitted by the slave.

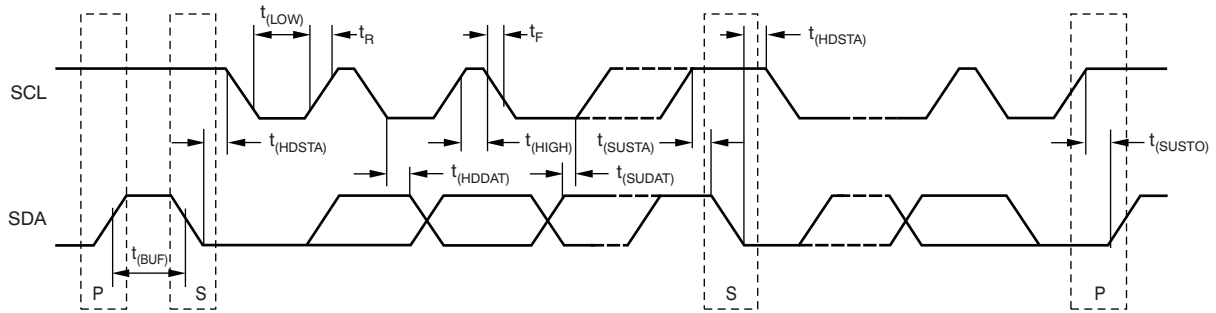

NOTE: P = STOP, S = START.

Figure 1. Two-Wire Timing Diagram

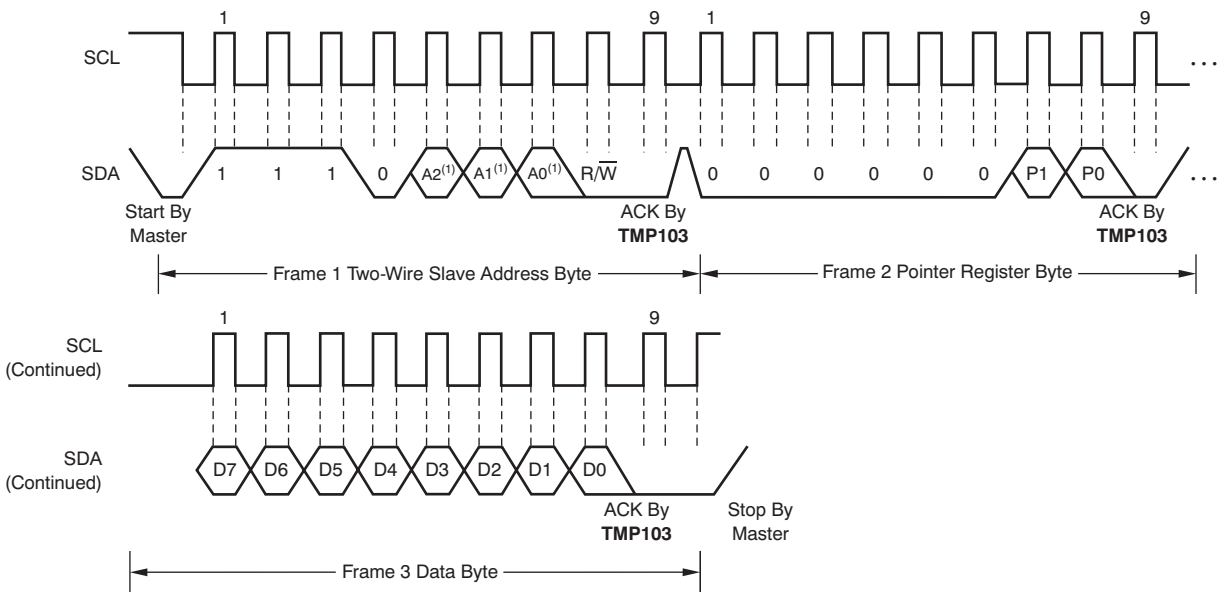

(1) The value of A0, A1, and A2 are determined by the TMP103 version; see Table 2.

Figure 2. Two-Wire Timing Diagram for Write Word Format

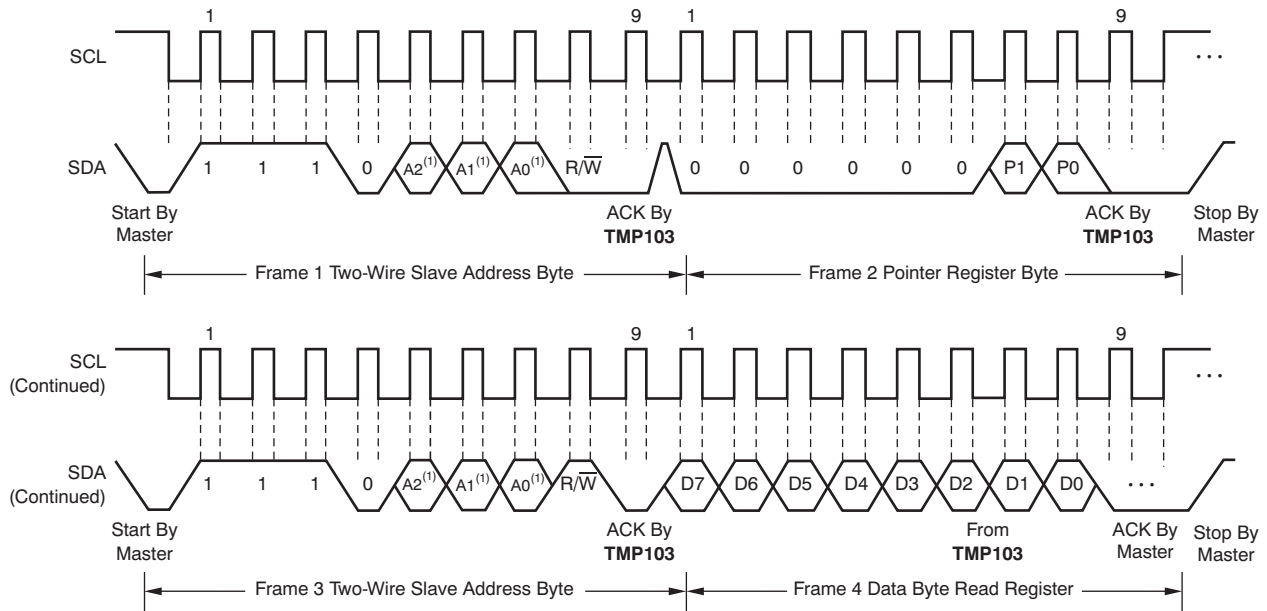

(1) The value of A0, A1, and A2 are determined by the TMP103 version; see Table 2.

Figure 3. Two-Wire Timing Diagram for Read Word Format

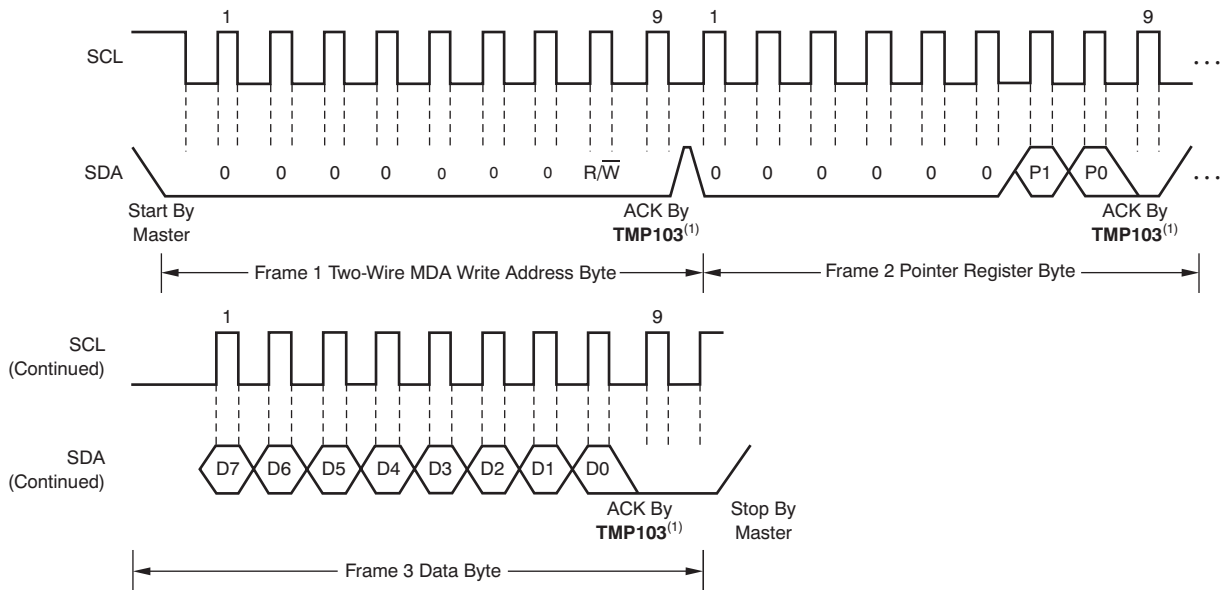

(1) All TMP103 devices on the bus acknowledge the byte.

Figure 4. Two-Wire Timing Diagram MDA Write Word Format

TMP103

SBOS545D – FEBRUARY 2011 – REVISED DECEMBER 2018

www.ti.com

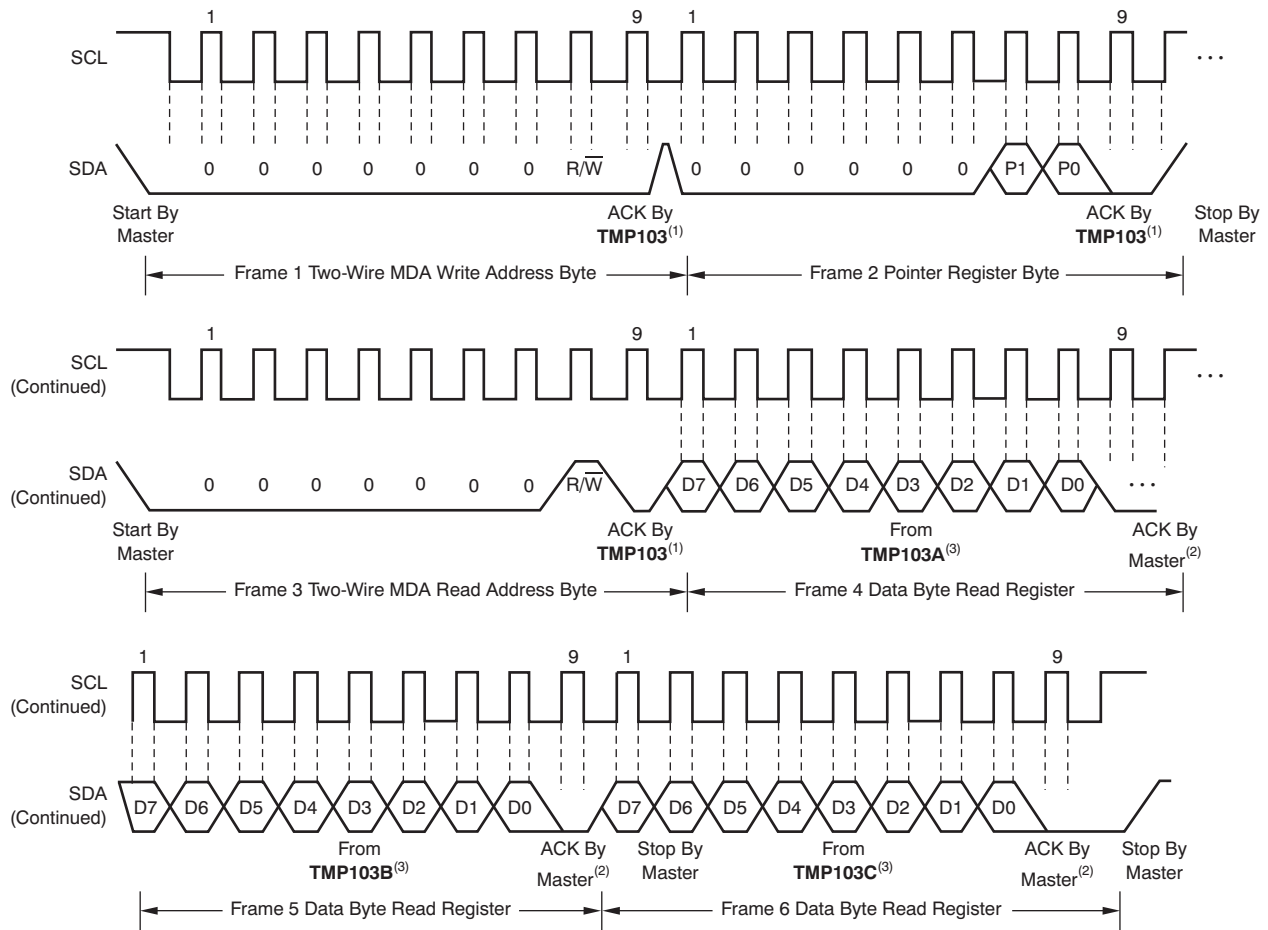

- (1) All TMP103 devices on the bus acknowledge the byte.
- (2) The master must issue an acknowledge for each byte read to read all of the TMP103 devices on the bus.
- (3) Three TMP103 devices used in this case; up to eight devices can be used (see Table 2).

Figure 5. Two-Wire Timing Diagram MDA Read Word Format Using Figure 16 (Typical Application)

6.7 Typical Characteristics

At $T_A = 25^\circ\text{C}$ and $V^+ = 1.8\text{ V}$, unless otherwise noted.

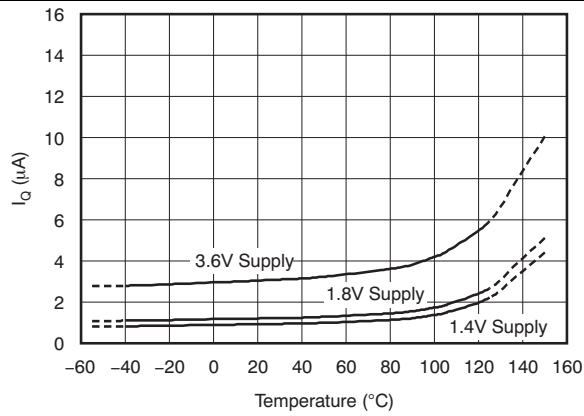

Figure 6. Quiescent Current vs Temperature (0.25 Conversions Per Second)

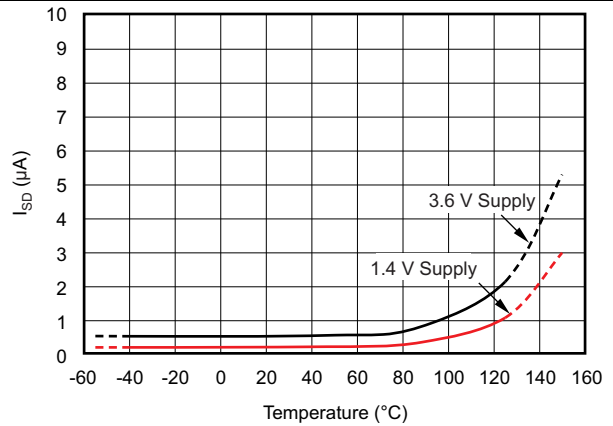

Figure 7. Shutdown Current vs Temperature

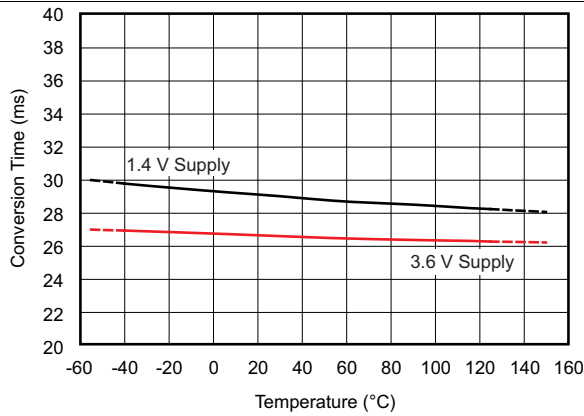

Figure 8. Conversion Time vs Temperature

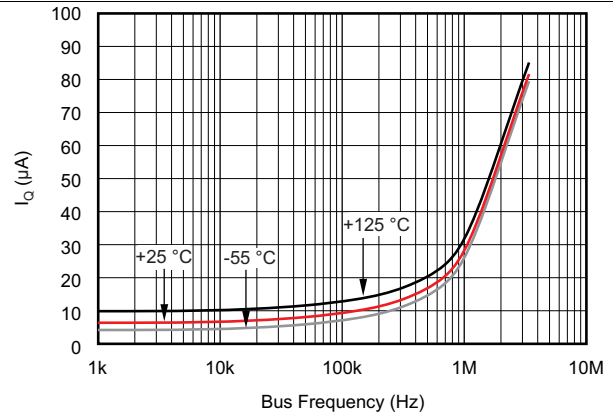

Figure 9. Quiescent Current vs Bus Frequency (Temperature at 3.3-V Supply)

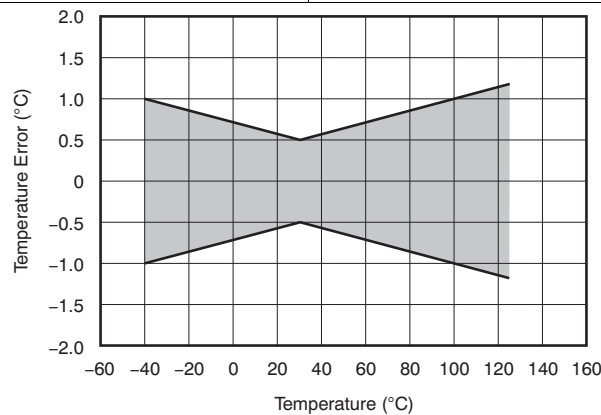

Figure 10. Temperature Error vs Temperature

7 Detailed Description

7.1 Overview

The TMP103 is a digital output temperature sensor in a wafer chip-scale package (WCSP) that is optimal for thermal management and thermal profiling. The TMP103 includes a two-wire interface that is compatible with both I²C and SMBus interfaces. In addition, the TMP103 has the capability of executing multiple device access (MDA) commands that allow multiple TMP103 devices to respond to a single global bus command. MDA commands reduce communication time and power in a bus that contains multiple TMP103 devices. The TMP103 is specified over a temperature range of –40°C to 125°C.

The TMP103 serial interface is designed to support up to eight TMP103 devices on a single bus. The TMP103 is offered with eight internal interface addresses. Each unique address option can be used as a location or temperature zone designator. The TMP103 responds to standard I²C and SMBus slave protocols that allow the internal registers to be written to or read from on an individual basis. The TMP103 also responds to MDA commands that allow all the devices on the bus to be written to or read from, without having to send the individual address and commands to each device.

Pullup resistors are required on SCL and SDA. TI also recommends a 0.01-μF bypass capacitor, as shown in Figure 11.

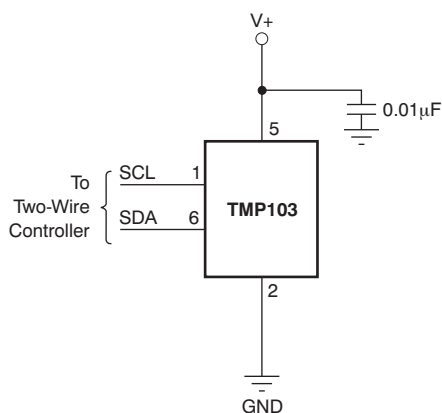

NOTE: SCL and SDA pins require pullup resistors.

Figure 11. Typical Connections

The temperature sensor in the TMP103 is the chip itself. Thermal paths run through the package bumps as well as the package. The lower thermal resistance of metal causes the bumps to provide the primary thermal path.

To maintain accuracy in applications that require air or surface temperature measurement, take care to isolate the package from ambient air temperature.

7.2 Functional Block Diagram

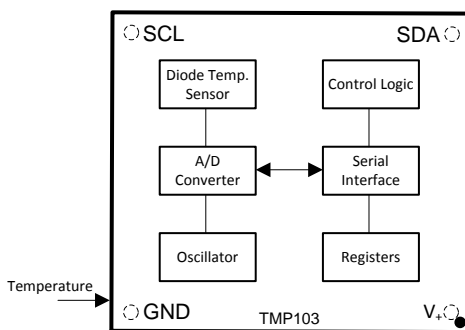

7.3 Feature Description

The TMP103 is a 1°C resolution digital output temperature sensor offered in a four-ball wafer chip-scale package (WCSP). The TMP103 features a two-wire interface that is compatible with both I²C and SMBus interfaces.

The serial interface supports multiple device access (MDA) commands that allow the master to communicate with multiple devices on the bus simultaneously, eliminating the need to send individual commands to each TMP103 device on the bus. Up to eight TMP103 devices can be tied together in parallel and easily read by the host.

The TMP103 is an ideal choice for space-constrained and power-sensitive applications with multiple temperature measurement zones to be monitored.

7.4 Device Functional Modes

7.4.1 Shutdown Mode

Shutdown mode saves maximum power by shutting down all device circuitry other than the serial interface, reducing current consumption to typically less than 0.5 μ A. For details on how to enter shutdown mode, see [Shutdown Mode \(\$M1 = 0, M0 = 0\$ \)](#) in [Programming](#).

7.4.2 One-Shot Mode

The TMP103 features a One-Shot Temperature Measurement mode. When the device is in Shutdown mode, the device can be instructed to complete a one-time temperature measurement before returning to the shutdown state. This feature is useful for reducing power consumption in the TMP103 when continuous temperature monitoring is not required.

As a result of the short conversion time, the TMP103 can achieve a higher conversion rate. A single conversion typically takes 26 ms and a read can take place in less than 20 μ s. When using One-Shot mode, 30 or more conversions per second are possible.

For details on how to enter One-Shot mode, see [One-Shot \(\$M1 = 0, M0 = 1\$ \)](#) in [Programming](#).

7.4.3 Continuous Conversion Mode

In Continuous Conversion mode, the TMP103 performs temperature conversion at a rate determined by the conversion rate bits (CR1 and CR0) set in the configuration register. Because the actual temperature conversion takes only 26 mS, the TMP103 powers down in between conversions and waits for the appropriate delay. For details on how to enter One-Shot mode, see [Continuous Conversion Mode \(\$M1 = 1\$ \)](#) and [Conversion Rate](#) in [Programming](#).

7.5 Programming

7.5.1 Temperature Watchdog Function

The TMP103 contains a watchdog function that monitors device temperature and compares the result to the values stored in the temperature limit registers (T_{HIGH} and T_{LOW}) to determine if the device temperature is within these set limits. If the temperature of the TMP103 becomes greater than the value in the T_{HIGH} register, then the flag-high bit (FH) in the configuration register is set to 1. If the temperature falls below the value in the T_{LOW} register, then the flag-low bit (FL) is set to 1. If both flag bits remain 0, then the temperature is within the temperature *window* set by the temperature limit registers, as shown in [Figure 12](#).

Programming (continued)

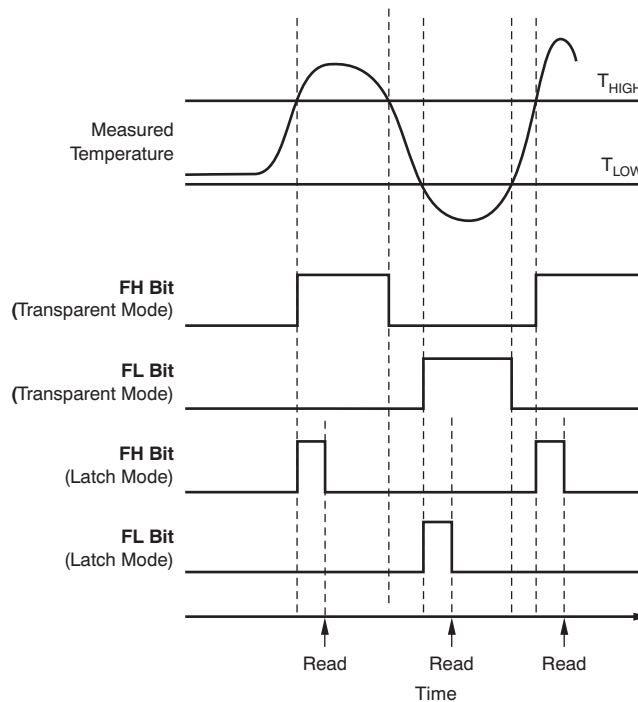

Figure 12. Temperature Flag Functional Diagram

The latch bit (LC) in the configuration register is used to latch the value of the flag bits (FH and FL) until the master issues a read command to the configuration register. The flag bits are set to 0 if a read command is received by the TMP103, or if LC = 0 and the temperature is within the temperature limits. The power-on default values for these bits are FH = 0, FL = 0, and LC = 0.

7.5.2 Conversion Rate

The conversion rate bits, CR1 and CR0 located in the Configuration Register, configure the TMP103 for conversion rates of 8 Hz, 4 Hz, 1 Hz, or 0.25 Hz (default). The TMP103 has a typical conversion time of 26 ms. To achieve different conversion rates, the TMP103 performs a single conversion and then powers down and waits for the appropriate delay set by CR1 and CR0. [Table 1](#) lists the settings for CR1 and CR0.

Table 1. Conversion Rate Settings

CR1	CR0	CONVERSION RATE
0	0	0.25 Hz (default)
0	1	1 Hz
1	0	4 Hz
1	1	8 Hz

After power up or general-call reset, the TMP103 immediately starts a conversion, as shown in Figure 13. The first result is available after 26 ms (typical). The active quiescent current during conversion is 40 μA (typical at 27°C, $V^+ = 1.8\text{ V}$). The quiescent current during delay is 1 μA (typical at 27°C, $V^+ = 1.8\text{ V}$).

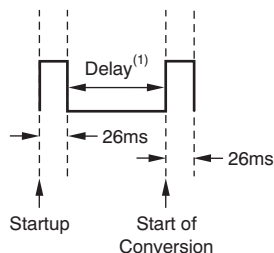

(1) Delay is set by CR1 and CR0.

Figure 13. Conversion Start

7.5.3 Shutdown Mode (M1 = 0, M0 = 0)

Shutdown mode saves maximum power by shutting down all device circuitry other than the serial interface, reducing current consumption to typically less than 0.5 μA . Shutdown mode is enabled when bits M1 and M0 (in the Configuration Register) = 00. The device shuts down when the current conversion is completed.

7.5.4 One-Shot (M1 = 0, M0 = 1)

The TMP103 features a One-Shot Temperature Measurement mode. When the device is in Shutdown mode, writing a 01 to bits M1 and M0 starts a single temperature conversion. During the conversion, bits M1 and M0 read 01. The device returns to the shutdown state at the completion of the single conversion. After the conversion, bits M1 and M0 read 00. This feature is useful for reducing power consumption in the TMP103 when continuous temperature monitoring is not required.

As a result of the short conversion time, the TMP103 can achieve a higher conversion rate. A single conversion typically takes 26 ms and a read can take place in less than 20 μs . When using One-Shot mode, 30 or more conversions per second are possible.

7.5.5 Continuous Conversion Mode (M1 = 1)

When the TMP103 is in Continuous Conversion mode (M1 = 1), a single conversion is performed at a rate determined by the conversion rate bits, CR1 and CR0 (in the Configuration Register). The TMP103 performs a single conversion and then powers down and waits for the appropriate delay set by CR1 and CR0. See Table 1 for CR1 and CR0 settings.

7.5.6 Bus Overview

The device that initiates the transfer is called a *master*, and the devices controlled by the master are *slaves*. The bus must be controlled by a master device that generates the serial clock (SCL), controls the bus access, and generates the START and STOP conditions.

To address a specific device, a START condition is initiated, indicated by pulling the data line (SDA) from a high to low logic level while SCL is high. All slaves on the bus shift in the slave address byte on the rising edge of the clock, with the last bit indicating whether a read or write operation is intended. During the ninth clock pulse, the slave being addressed responds to the master by generating an Acknowledge and pulling SDA low.

Data transfer is then initiated and sent over eight clock pulses followed by an Acknowledge Bit. During data transfer, SDA must remain stable while SCL is high, because any change in SDA while SCL is high is interpreted as a START or STOP signal.

Once all data have been transferred, the master generates a STOP condition indicated by pulling SDA from low to high, while SCL is high.

7.5.7 Serial Interface

The TMP103 operates as a slave device only on the two-wire bus and SMBus. Connections to the bus are made through the open-drain I/O lines SDA and SCL. The SDA and SCL pins feature integrated spike suppression filters and Schmitt triggers to minimize the effects of input spikes and bus noise. The TMP103 supports the transmission protocol for both fast (1 kHz to 400 kHz) and high-speed (1 kHz to 3.4 MHz) modes. All data bytes are transmitted MSB first.

7.5.8 Serial Bus Address

To communicate with the TMP103, the master must first address slave devices through a slave address byte. The slave address byte consists of seven address bits, and a direction bit that indicates the intent of executing a read or write operation.

The TMP103 is available in eight versions, each with a different slave address, as shown in [Table 2](#). These addresses can be used as either a location or a temperature zone designator.

Table 2. Device Slave Addresses

PRODUCT	TWO-WIRE ADDRESS	TEMPERATURE ZONE
TMP103A	1110000	Zone1
TMP103B	1110001	Zone2
TMP103C	1110010	Zone3
TMP103D	1110011	Zone4
TMP103E	1110100	Zone5
TMP103F	1110101	Zone6
TMP103G	1110110	Zone7
TMP103H	1110111	Zone8

7.5.9 Writing and Reading Operation

Accessing a particular register on the TMP103 is accomplished by writing the appropriate value to the Pointer Register. The value for the Pointer Register is the first byte transferred after the slave address byte with the R/W bit low. Every write operation to the TMP103 requires a value for the Pointer Register (see [Figure 2](#)).

When reading from the TMP103, the last value stored in the Pointer Register by a write operation is used to determine which register is read by a read operation. To change the register pointer for a read operation, a new value must be written to the Pointer Register. This action is accomplished by issuing a slave address byte with the R/W bit low, followed by the Pointer Register byte. No additional data are required. The master can then generate a START condition and send the slave address byte with the R/W bit high to initiate the read command. See [Figure 3](#) for details of this sequence. If repeated reads from the same register are desired, it is not necessary to continually send the Pointer Register bytes; the TMP103 remembers the Pointer Register value until it is changed by the next write operation, or the TMP103 is reset.

7.5.10 Slave Mode Operations

The TMP103 can operate as a slave receiver or slave transmitter. As a slave device, the TMP103 never drives the SCL line.

7.5.10.1 Slave Receiver Mode

The first byte transmitted by the master is the slave address, with the $\overline{R/W}$ bit low. The TMP103 then acknowledges reception of a valid address. The next byte transmitted by the master is the Pointer Register. The TMP103 then acknowledges reception of the Pointer Register byte. The next byte is written to the register addressed by the Pointer Register. The TMP103 acknowledges reception of the data byte. The master can terminate data transfer by generating a START or STOP condition.

7.5.10.2 Slave Transmitter Mode

The first byte transmitted by the master is the slave address, with the R/\overline{W} bit high. The slave acknowledges reception of a valid slave address. The next byte is transmitted by the slave of the register indicated by the Pointer Register. The master acknowledges reception of the data byte. The master can terminate data transfer by generating a *Not-Acknowledge* on reception of the data byte, or generating a START or STOP condition.

7.5.11 General Call

The TMP103 responds to a two-wire General Call address (0000000) if the eighth bit is 0. The device acknowledges the General Call address and responds to commands in the second byte. If the second byte is 00000110, the TMP103 internal registers are reset to power-up values. The TMP103 does not support the General Address acquire command.

7.5.12 High-Speed (Hs) Mode

For the two-wire bus to operate at frequencies greater than 400 kHz, the master device must issue an Hs-mode master code (00001xxx) as the first byte after a START condition to switch the bus to high-speed operation. The TMP103 does not acknowledge this byte, but switches its input filters on SDA and SCL and its output filters on SDA to operate in Hs-mode, allowing transfers at up to 3.4 MHz. After the Hs-mode master code has been issued, the master transmits a START condition followed by a two-wire slave address to initiate a data transfer operation. The bus continues to operate in Hs-mode until a STOP condition occurs on the bus. Upon receiving the STOP condition, the TMP103 switches the input and output filters back to the default fast-mode operation.

7.5.13 Timeout Function

The TMP103 resets the serial interface if SCL is held low for 30 ms (typical). The TMP103 releases the bus if it is pulled low and waits for a START condition. To avoid activating the timeout function, it is necessary to maintain a communication speed of at least 1 kHz for SCL operating frequency.

7.5.14 Multiple Device Access

The TMP103 supports Multiple Device Access (MDA), which allows the master to communicate with multiple TMP103 devices on the same bus interface with one interface transaction. MDA commands consist of an MDA read address (00000001) and an MDA write address (00000000). The device acknowledges the MDA address and responds to the command accordingly. For the MDA to function correctly, different product versions of the TMP103 must be used in the system; see [Table 2](#).

7.5.14.1 Multiple Device Access Write

The master transmits an MDA write address followed by the pointer address of the register to be accessed; see [Table 4](#). Following the pointer, all of the TMP103 devices on the bus acknowledge and wait for the next byte of data to be written to the addressed registers. When the data byte is received by the TMP103 devices, they store and acknowledge the transmitted byte. The TMP103 devices store the same data on all devices on the bus in one transaction; see [Figure 4](#).

7.5.14.2 Multiple Device Access Read

Before an MDA read transaction can begin, the master must first send an MDA write transaction to set the appropriate pointer address of the register to be accessed, as stated in the previous section. The master can then transmit an MDA read address followed by a read byte for each TMP103 used on the bus. For example, if a TMP103A and TMP103B are used on the same bus and an MDA read address is sent, the address must be followed by two bytes of data and two master acknowledges. The TMP103A sends data on the first byte and the TMP103B sends data on the second byte. The master must issue an acknowledge for each byte read to read all of the TMP103 devices on the bus; see [Figure 5](#). If the master does not acknowledge each byte of data, the TMP103s stop sending subsequent data for any remaining devices.

Up to eight TMP103 devices can be on the same bus and respond to MDA commands; see [Table 2](#).

NOTE

If the bus contains an incomplete sequence of TMP103 device addresses, the master must transmit all required dummy bytes for the missing device address to allow for normal MDA read operation. For example, if the TMP103A, TMP103B, and TMP103D devices are on the bus, the master must transmit an MDA read address followed by four bytes and four acknowledges to complete the MDA read transaction.

7.5.15 NOISE

The TMP103 is a very low-power device and generates very low noise on the supply bus. Applying an RC filter to the V⁺ pin of the TMP103 can further reduce any noise the TMP103 might propagate to other components. R_F in [Figure 14](#) should be less than 5 kΩ and C_F should be greater than 10 nF.

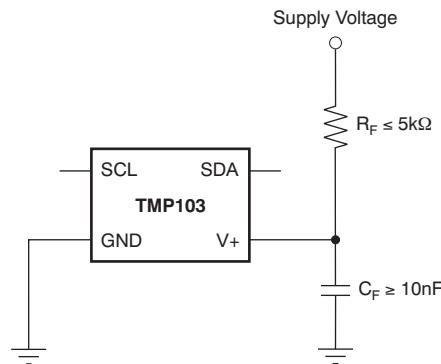
Figure 14. Noise Reduction
7.6 Register Maps
7.6.1 Pointer Register

[Figure 15](#) shows the internal register structure of the TMP103. The 8-bit Pointer Register of the device is used to address a given data register. The Pointer Register uses the two LSBs to identify which of the data registers should respond to a read or write command. [Table 3](#) identifies the bits of the Pointer Register byte. During a write command, P2 through P7 must always be 0. [Table 4](#) describes the pointer address of the registers available in the TMP103. Power-up reset value of P1/P0 is 00. By default, the TMP103 reads the temperature on power up.

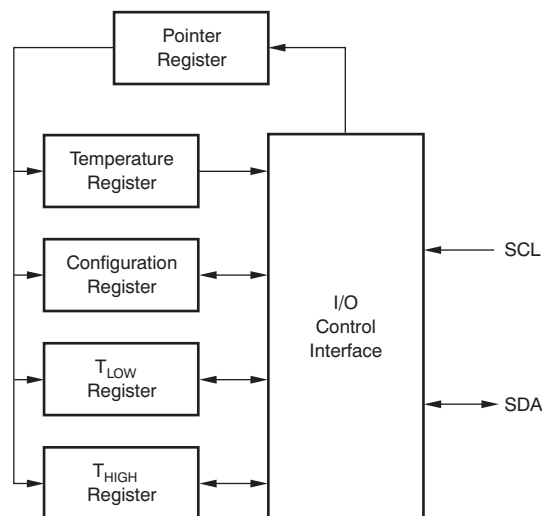
Figure 15. Internal Register Structure

Register Maps (continued)
Table 3. Pointer Register Byte

P7	P6	P5	P4	P3	P2	P1	P0
0	0	0	0	0	0	Register Bits	

Table 4. Pointer Addresses

P1	P0	REGISTER
0	0	Temperature Register (Read Only)
0	1	Configuration Register (Read/Write)
1	0	T _{LOW} Register (Read/Write)
1	1	T _{HIGH} Register (Read/Write)

7.6.2 Temperature Register

The Temperature Register of the TMP103 device is configured as an eight-bit, read-only register that stores the output of the most recent conversion. A single byte must be read to obtain data, and is described in [Table 5](#). The data format for temperature is summarized in [Table 6](#). One LSB equals 1°C.

Table 5. Temperature Register

D7	D6	D5	D4	D3	D2	D1	D0
T7	T6	T5	T4	T3	T2	T1	T0

Negative numbers are represented in binary twos complement format. Following power up or reset, the Temperature Register reads 0°C until the first conversion is complete.

Table 6. 8-Bit Temperature Data Format⁽¹⁾

TEMPERATURE (°C)	DIGITAL OUTPUT (BINARY)	HEX
128	0111 1111	7F
127	0111 1111	7F
100	0110 0100	64
80	0101 0000	50
75	0100 1011	4B
50	0011 0010	32
25	0001 1001	19
0	0000 0000	00
-1	1111 1111	FF
-25	1110 0111	E7
-55	1100 1001	C9

(1) The resolution for the ADC is 1°C/count, where *count* is equal to the digital output of the ADC.

For positive temperatures (for example, 50°C):

Twos complement is not performed on positive numbers. Therefore, simply convert the number to binary code, left-justified format. Denote a positive number with MSB = 0.

Example: $(50^{\circ}\text{C}) / (1^{\circ}\text{C}/\text{count}) = 50 = 32\text{h} = 0011\ 0010$

For negative temperatures (for example, -25°C):

Generate the twos complement of a negative number by complementing the absolute value binary number and adding 1. Denote a negative number with MSB = 1.

Example: $(|-25^{\circ}\text{C}|) / (1^{\circ}\text{C}/\text{count}) = 25 = 19\text{h} = 0001\ 1001$

Twos complement format: $1110\ 0110 + 1 = 1110\ 0111$

7.6.3 Configuration Register

The Configuration Register is an eight-bit read/write register used to store bits that control the operational modes of the temperature sensor. Read/write operations are performed MSB first. The format and power-up and reset value of the Configuration Register is shown in [Table 7](#). All registers are updated at the end of the data byte.

Table 7. Configuration and Power-Up and Reset Format

D7	D6	D5	D4	D3	D2	D1	D0
ID	CR1	CR0	FH	FL	LC	M1	M0
0	0	0	0	0	0	1	0

7.6.4 Temperature Limit Registers

The T_{HIGH} and T_{LOW} registers are used to store the temperature limit thresholds for the TMP103 watchdog function. At the end of each temperature measurement, the TMP103 compares the temperature results to each of these limits. If the temperature result is greater than the T_{HIGH} limit, then the FH bit in the configuration register is set to 1. If the temperature result is less than the T_{LOW} limit, then the FL bit in the configuration register is set to 1; see [Figure 12](#).

[Table 8](#) and [Table 9](#) describe the format for the T_{HIGH} and T_{LOW} registers. Power-up reset values for T_{HIGH} and T_{LOW} are: $T_{HIGH} = 60^{\circ}\text{C}$ and $T_{LOW} = -10^{\circ}\text{C}$. The format of the data for T_{HIGH} and T_{LOW} is the same as for the Temperature Register.

Table 8. T_{HIGH} Register

D7	D6	D5	D4	D3	D2	D1	D0
H7	H6	H5	H4	H3	H2	H1	H0

Table 9. T_{LOW} Register

D7	D6	D5	D4	D3	D2	D1	D0
L7	L6	L5	L4	L3	L2	L1	L0

8 Application and Implementation

NOTE

Information in the following applications sections is not part of the TI component specification, and TI does not warrant its accuracy or completeness. TI's customers are responsible for determining suitability of components for their purposes. Customers should validate and test their design implementation to confirm system functionality.

8.1 Application Information

The TMP103 is a digital output temperature sensor in a DSBGA package that is optimal for thermal management and thermal profiling. The TMP103 includes a two-wire interface that is compatible with both I²C and SMBus interfaces. In addition, the TMP103 has the capability of executing multiple device access (MDA) commands that allows multiple TMP103 devices to respond to a single global bus command. MDA commands reduce communication time and power in a bus that contains multiple TMP103 devices. The TMP103 is specified over a temperature range of –40°C to 125°C.

The TMP103 serial interface is designed to support up to eight TMP103 devices on a single bus. The TMP103 is offered with eight internal interface addresses. Each unique address option can be used as a location or temperature zone designator. The TMP103 responds to standard I²C and SMBus slave protocols that allow the internal registers to be written to or read from on an individual basis. The TMP103 also responds to MDA commands that allow all the devices on the bus to be written to or read from, without having to send the individual address and commands to each device.

8.2 Typical Application

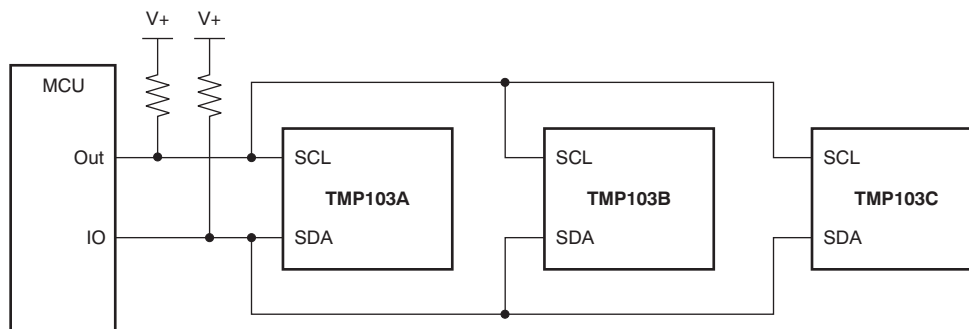

Figure 16. Typical Application Diagram

8.2.1 Design Requirements

The TMP103 device requires pullup resistors on the SCL and SDA pins. The pullup resistor values must be selected such that the maximum current sinking capability of I/O pins is not violated. TI recommends a 0.01- μ F bypass capacitor on the supply.

8.2.2 Detailed Design Procedure

The TMP103 devices must be placed in close proximity to the heat source that must be monitored, with a proper layout for good thermal coupling. This placement ensures that temperature changes are captured within the shortest possible time interval. To maintain accuracy in applications that require air or surface temperature measurement, take care to isolate the package and leads from ambient air temperature. The TMP103 device is a very low-power device and generates very low noise on the supply bus. Applying an RC filter to the V⁺ pin of the TMP103 device can further reduce any noise that the TMP103 device might propagate to other components.

Typical Application (continued)

8.2.3 Application Curve

Table 9 shows the step response of the TMP103 device to a submersion in an oil bath of 100°C from room temperature (25°C). The time-constant, or the time for the output to reach 63% of the input step, is 1.4 s. The time-constant result depends on the printed-circuit-board (PCB) that the TMP103 device is mounted. For this test, there are eight TMP103 devices soldered to a two-layer PCB that measured 2 in x 2 in, and the PCB thickness is 64 mils.

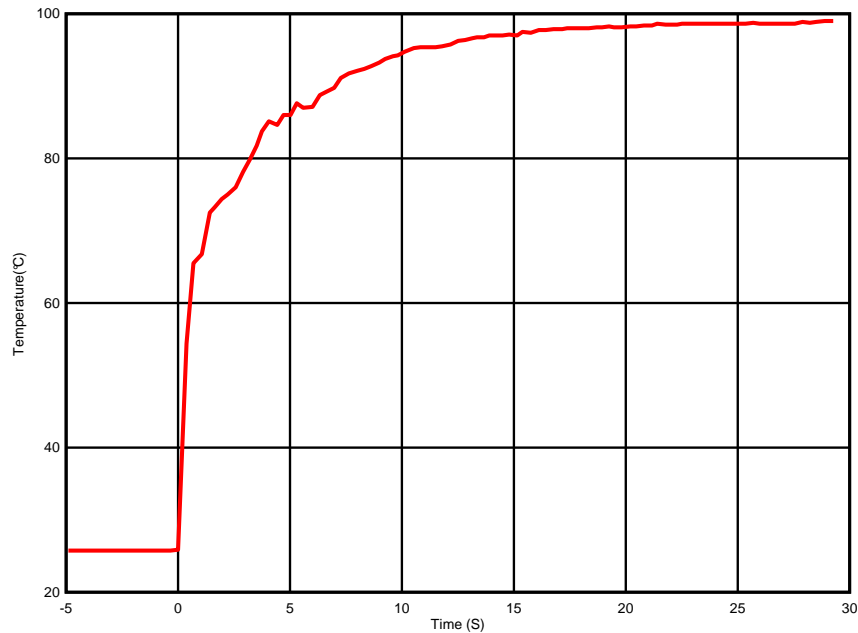

Figure 17. Temperature vs Time

9 Power Supply Recommendations

The TMP103 device operates with power supply in the range of 1.4 V to 3.6 V. The device is optimized for operation at 3.3-V supply but can measure temperature accurately in the full supply range. A power-supply bypass capacitor is required for proper operation. Place this capacitor as close as possible to the supply and ground pins of the device. A typical value for this supply bypass capacitor is 0.01 μF . Applications with noisy or high-impedance power supplies may require additional decoupling capacitors to reject power-supply noise.

10 Layout

10.1 Layout Guidelines

Place the power-supply bypass capacitor as close as possible to the supply pin. The recommended value of this bypass capacitor is 0.01 μF . Additional decoupling capacitance can be added to compensate for noisy or high-impedance power supplies. Pull up the SDA and SCL pins through 5-k Ω pullup resistors.

10.2 Layout Example

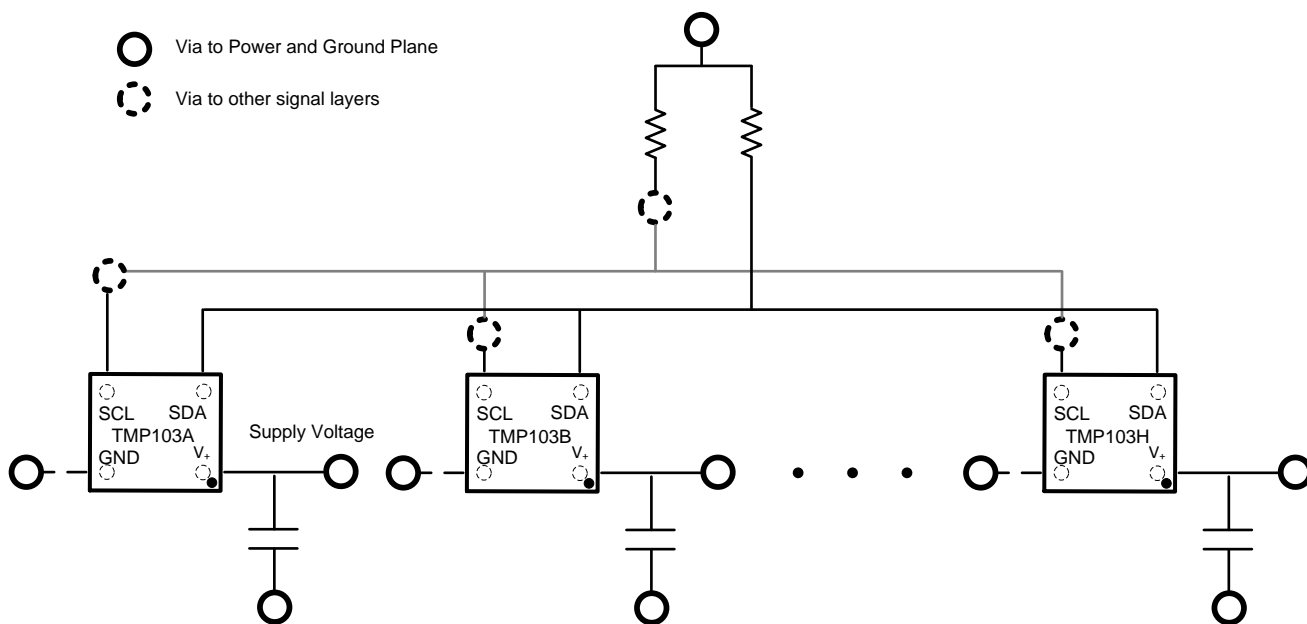

Figure 18. Recommended Layout Example

11 Device and Documentation Support

11.1 Receiving Notification of Documentation Updates

To receive notification of documentation updates, navigate to the device product folder on ti.com. In the upper right corner, click on *Alert me* to register and receive a weekly digest of any product information that has changed. For change details, review the revision history included in any revised document.

11.2 Community Resources

The following links connect to TI community resources. Linked contents are provided "AS IS" by the respective contributors. They do not constitute TI specifications and do not necessarily reflect TI's views; see TI's [Terms of Use](#).

TI E2E™ Online Community *TI's Engineer-to-Engineer (E2E) Community*. Created to foster collaboration among engineers. At e2e.ti.com, you can ask questions, share knowledge, explore ideas and help solve problems with fellow engineers.

Design Support *TI's Design Support* Quickly find helpful E2E forums along with design support tools and contact information for technical support.

11.3 Trademarks

E2E is a trademark of Texas Instruments.

SMBus is a trademark of Intel.

I²C is a trademark of NXP Semiconductors.

All other trademarks are the property of their respective owners.

11.4 Electrostatic Discharge Caution



These devices have limited built-in ESD protection. The leads should be shorted together or the device placed in conductive foam during storage or handling to prevent electrostatic damage to the MOS gates.

11.5 Glossary

[SLYZ022](#) — *TI Glossary*.

This glossary lists and explains terms, acronyms, and definitions.

12 Mechanical, Packaging, and Orderable Information

The following pages include mechanical, packaging, and orderable information. This information is the most current data available for the designated devices. This data is subject to change without notice and revision of this document. For browser-based versions of this data sheet, refer to the left-hand navigation.

PACKAGING INFORMATION

Orderable Device	Status (1)	Package Type	Package Drawing	Pins	Package Qty	Eco Plan (2)	Lead/Ball Finish (6)	MSL Peak Temp (3)	Op Temp (°C)	Device Marking (4/5)	Samples
TMP103AYFFR	ACTIVE	DSBGA	YFF	4	3000	Green (RoHS & no Sb/Br)	SNAGCU	Level-1-260C-UNLIM	-40 to 125	TA	Samples
TMP103AYFFT	ACTIVE	DSBGA	YFF	4	250	Green (RoHS & no Sb/Br)	SNAGCU	Level-1-260C-UNLIM	-40 to 125	TA	Samples
TMP103BYFFR	ACTIVE	DSBGA	YFF	4	3000	Green (RoHS & no Sb/Br)	SNAGCU	Level-1-260C-UNLIM	-40 to 125	TB	Samples
TMP103BYFFT	ACTIVE	DSBGA	YFF	4	250	Green (RoHS & no Sb/Br)	SNAGCU	Level-1-260C-UNLIM	-40 to 125	TB	Samples
TMP103CYFFR	ACTIVE	DSBGA	YFF	4	3000	Green (RoHS & no Sb/Br)	SNAGCU	Level-1-260C-UNLIM	-40 to 125	TC	Samples
TMP103CYFFT	ACTIVE	DSBGA	YFF	4	250	Green (RoHS & no Sb/Br)	SNAGCU	Level-1-260C-UNLIM	-40 to 125	TC	Samples
TMP103DYFFR	ACTIVE	DSBGA	YFF	4	3000	Green (RoHS & no Sb/Br)	SNAGCU	Level-1-260C-UNLIM	-40 to 125	TD	Samples
TMP103DYFFT	ACTIVE	DSBGA	YFF	4	250	Green (RoHS & no Sb/Br)	SNAGCU	Level-1-260C-UNLIM	-40 to 125	TD	Samples
TMP103EYFFR	ACTIVE	DSBGA	YFF	4	3000	Green (RoHS & no Sb/Br)	SNAGCU	Level-1-260C-UNLIM	-40 to 125	TE	Samples
TMP103EYFFT	ACTIVE	DSBGA	YFF	4	250	Green (RoHS & no Sb/Br)	SNAGCU	Level-1-260C-UNLIM	-40 to 125	TE	Samples
TMP103FYFFR	ACTIVE	DSBGA	YFF	4	3000	Green (RoHS & no Sb/Br)	SNAGCU	Level-1-260C-UNLIM	-40 to 125	TF	Samples
TMP103FYFFT	ACTIVE	DSBGA	YFF	4	250	Green (RoHS & no Sb/Br)	SNAGCU	Level-1-260C-UNLIM	-40 to 125	TF	Samples
TMP103GYFFR	ACTIVE	DSBGA	YFF	4	3000	Green (RoHS & no Sb/Br)	SNAGCU	Level-1-260C-UNLIM	-40 to 125	TG	Samples
TMP103GYFFT	ACTIVE	DSBGA	YFF	4	250	Green (RoHS & no Sb/Br)	SNAGCU	Level-1-260C-UNLIM	-40 to 125	TG	Samples
TMP103HYFFR	ACTIVE	DSBGA	YFF	4	3000	Green (RoHS & no Sb/Br)	SNAGCU	Level-1-260C-UNLIM	-40 to 125	TH	Samples
TMP103HYFFT	ACTIVE	DSBGA	YFF	4	250	Green (RoHS & no Sb/Br)	SNAGCU	Level-1-260C-UNLIM	-40 to 125	TH	Samples

(1) The marketing status values are defined as follows:
ACTIVE: Product device recommended for new designs.

LIFEBUY: TI has announced that the device will be discontinued, and a lifetime-buy period is in effect.

NRND: Not recommended for new designs. Device is in production to support existing customers, but TI does not recommend using this part in a new design.

PREVIEW: Device has been announced but is not in production. Samples may or may not be available.

OBSOLETE: TI has discontinued the production of the device.

⁽²⁾ **RoHS:** TI defines "RoHS" to mean semiconductor products that are compliant with the current EU RoHS requirements for all 10 RoHS substances, including the requirement that RoHS substance do not exceed 0.1% by weight in homogeneous materials. Where designed to be soldered at high temperatures, "RoHS" products are suitable for use in specified lead-free processes. TI may reference these types of products as "Pb-Free".

RoHS Exempt: TI defines "RoHS Exempt" to mean products that contain lead but are compliant with EU RoHS pursuant to a specific EU RoHS exemption.

Green: TI defines "Green" to mean the content of Chlorine (Cl) and Bromine (Br) based flame retardants meet JS709B low halogen requirements of ≤ 1000 ppm threshold. Antimony trioxide based flame retardants must also meet the ≤ 1000 ppm threshold requirement.

⁽³⁾ MSL, Peak Temp. - The Moisture Sensitivity Level rating according to the JEDEC industry standard classifications, and peak solder temperature.

⁽⁴⁾ There may be additional marking, which relates to the logo, the lot trace code information, or the environmental category on the device.

⁽⁵⁾ Multiple Device Markings will be inside parentheses. Only one Device Marking contained in parentheses and separated by a "~" will appear on a device. If a line is indented then it is a continuation of the previous line and the two combined represent the entire Device Marking for that device.

⁽⁶⁾ Lead/Ball Finish - Orderable Devices may have multiple material finish options. Finish options are separated by a vertical ruled line. Lead/Ball Finish values may wrap to two lines if the finish value exceeds the maximum column width.

Important Information and Disclaimer: The information provided on this page represents TI's knowledge and belief as of the date that it is provided. TI bases its knowledge and belief on information provided by third parties, and makes no representation or warranty as to the accuracy of such information. Efforts are underway to better integrate information from third parties. TI has taken and continues to take reasonable steps to provide representative and accurate information but may not have conducted destructive testing or chemical analysis on incoming materials and chemicals. TI and TI suppliers consider certain information to be proprietary, and thus CAS numbers and other limited information may not be available for release.

In no event shall TI's liability arising out of such information exceed the total purchase price of the TI part(s) at issue in this document sold by TI to Customer on an annual basis.

TAPE AND REEL INFORMATION

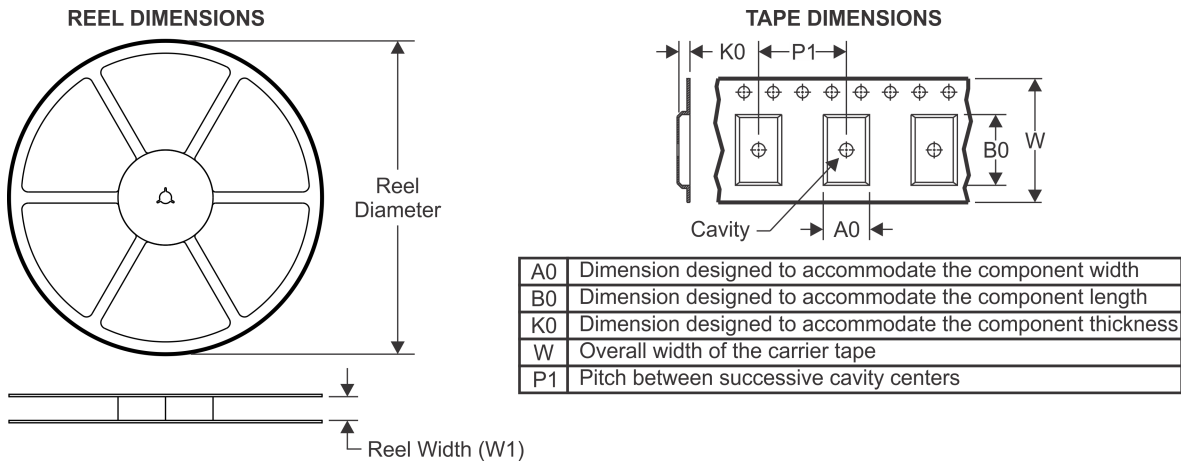

QUADRANT ASSIGNMENTS FOR PIN 1 ORIENTATION IN TAPE



*All dimensions are nominal

Device	Package Type	Package Drawing	Pins	SPQ	Reel Diameter (mm)	Reel Width W1 (mm)	A0 (mm)	B0 (mm)	K0 (mm)	P1 (mm)	W (mm)	Pin1 Quadrant
TMP103AYFFR	DSBGA	YFF	4	3000	180.0	8.4	0.85	0.85	0.64	4.0	8.0	Q1
TMP103AYFFT	DSBGA	YFF	4	250	180.0	8.4	0.85	0.85	0.64	4.0	8.0	Q1
TMP103BYFFR	DSBGA	YFF	4	3000	180.0	8.4	0.85	0.85	0.64	4.0	8.0	Q1
TMP103BYFFT	DSBGA	YFF	4	250	180.0	8.4	0.85	0.85	0.64	4.0	8.0	Q1
TMP103CYFFR	DSBGA	YFF	4	3000	180.0	8.4	0.85	0.85	0.64	4.0	8.0	Q1
TMP103CYFFT	DSBGA	YFF	4	250	180.0	8.4	0.85	0.85	0.64	4.0	8.0	Q1
TMP103DYFFR	DSBGA	YFF	4	3000	180.0	8.4	0.85	0.85	0.64	4.0	8.0	Q1
TMP103DYFFT	DSBGA	YFF	4	250	180.0	8.4	0.85	0.85	0.64	4.0	8.0	Q1
TMP103EYFFR	DSBGA	YFF	4	3000	180.0	8.4	0.85	0.85	0.64	4.0	8.0	Q1
TMP103EYFFT	DSBGA	YFF	4	250	180.0	8.4	0.85	0.85	0.64	4.0	8.0	Q1
TMP103FYFFR	DSBGA	YFF	4	3000	180.0	8.4	0.85	0.85	0.64	4.0	8.0	Q1
TMP103FYFFT	DSBGA	YFF	4	250	180.0	8.4	0.85	0.85	0.64	4.0	8.0	Q1
TMP103GYFFR	DSBGA	YFF	4	3000	180.0	8.4	0.85	0.85	0.64	4.0	8.0	Q1
TMP103GYFFT	DSBGA	YFF	4	250	180.0	8.4	0.85	0.85	0.64	4.0	8.0	Q1
TMP103HYFFR	DSBGA	YFF	4	3000	180.0	8.4	0.85	0.85	0.64	4.0	8.0	Q1
TMP103HYFFT	DSBGA	YFF	4	250	180.0	8.4	0.85	0.85	0.64	4.0	8.0	Q1

TAPE AND REEL BOX DIMENSIONS

*All dimensions are nominal

Device	Package Type	Package Drawing	Pins	SPQ	Length (mm)	Width (mm)	Height (mm)
TMP103AYFFR	DSBGA	YFF	4	3000	182.0	182.0	20.0
TMP103AYFFT	DSBGA	YFF	4	250	182.0	182.0	20.0
TMP103BYFFR	DSBGA	YFF	4	3000	182.0	182.0	20.0
TMP103BYFFT	DSBGA	YFF	4	250	182.0	182.0	20.0
TMP103CYFFR	DSBGA	YFF	4	3000	182.0	182.0	20.0
TMP103CYFFT	DSBGA	YFF	4	250	182.0	182.0	20.0
TMP103DYFFR	DSBGA	YFF	4	3000	182.0	182.0	20.0
TMP103DYFFT	DSBGA	YFF	4	250	182.0	182.0	20.0
TMP103EYFFR	DSBGA	YFF	4	3000	210.0	185.0	35.0
TMP103EYFFT	DSBGA	YFF	4	250	210.0	185.0	35.0
TMP103FYFFR	DSBGA	YFF	4	3000	210.0	185.0	35.0
TMP103FYFFT	DSBGA	YFF	4	250	210.0	185.0	35.0
TMP103GYFFR	DSBGA	YFF	4	3000	182.0	182.0	20.0
TMP103GYFFT	DSBGA	YFF	4	250	182.0	182.0	20.0
TMP103HYFFR	DSBGA	YFF	4	3000	182.0	182.0	20.0
TMP103HYFFT	DSBGA	YFF	4	250	182.0	182.0	20.0

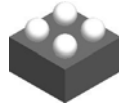

YFF0004

PACKAGE OUTLINE

DSBGA - 0.625 mm max height

DIE SIZE BALL GRID ARRAY

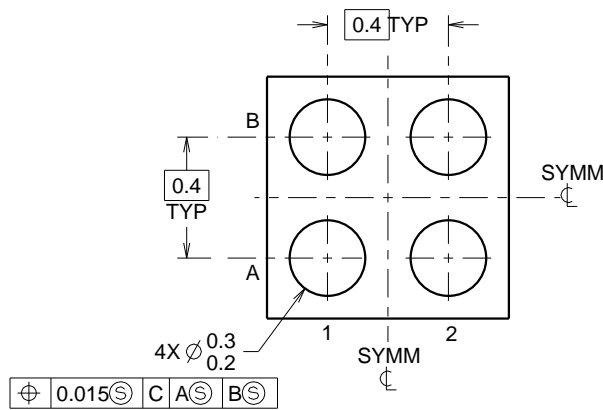
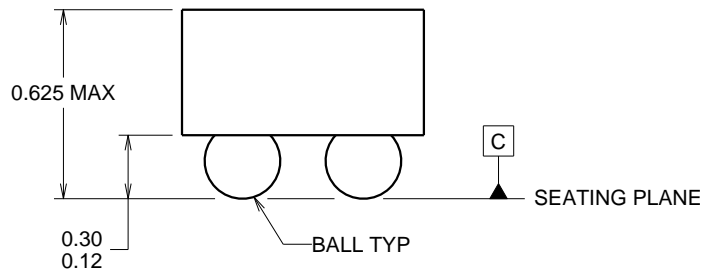
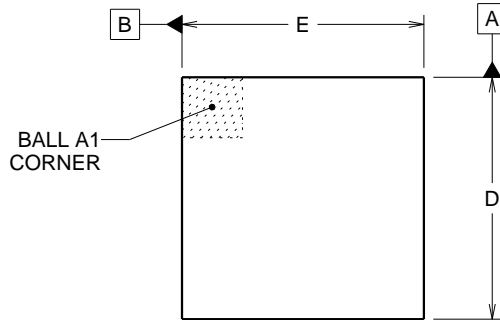

D: Max = 0.79 mm, Min = 0.73 mm
E: Max = 0.79 mm, Min = 0.73 mm

⊕	0.015	Ⓢ	C	A	Ⓢ	B	Ⓢ
---	-------	---	---	---	---	---	---

4219460/A 02/2014

NOTES:

NanoFree Is a trademark of Texas Instruments.

1. All linear dimensions are in millimeters. Any dimensions in parenthesis are for reference only. Dimensioning and tolerancing per ASME Y14.5M.
2. This drawing is subject to change without notice.
3. NanoFree™ package configuration.

EXAMPLE BOARD LAYOUT

YFF0004

DSBGA - 0.625 mm max height

DIE SIZE BALL GRID ARRAY

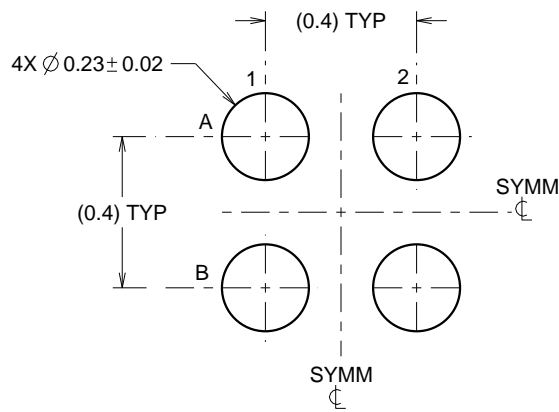

LAND PATTERN EXAMPLE
SCALE:50X

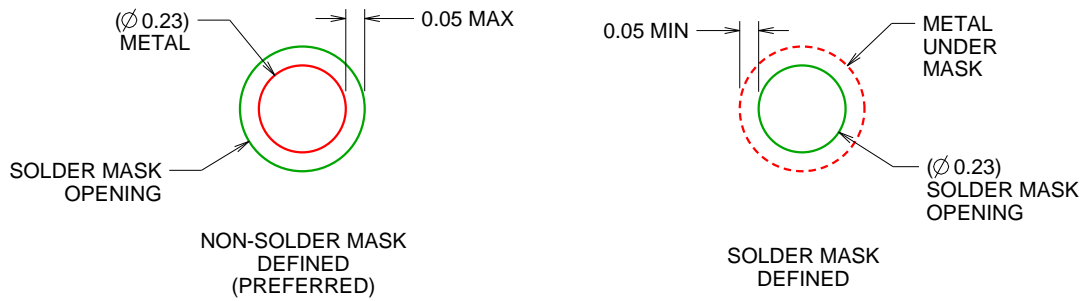

SOLDER MASK DETAILS
NOT TO SCALE

4219460/A 02/2014

NOTES: (continued)

- Final dimensions may vary due to manufacturing tolerance considerations and also routing constraints. For more information, see Texas Instruments literature number SBVA017 (www.ti.com/lit/sbva017).

EXAMPLE STENCIL DESIGN

YFF0004

DSBGA - 0.625 mm max height

DIE SIZE BALL GRID ARRAY

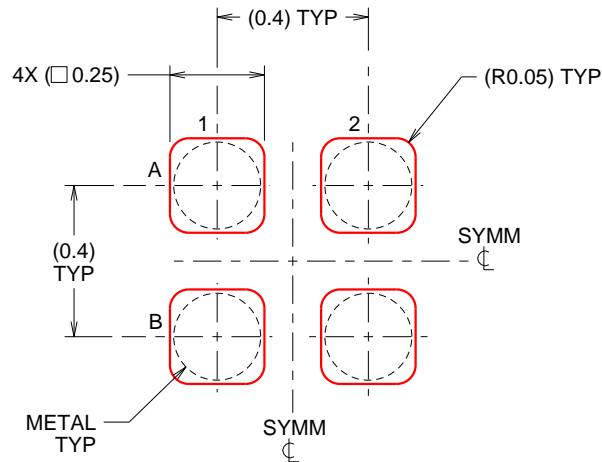

SOLDER PASTE EXAMPLE
BASED ON 0.1 mm THICK STENCIL
SCALE:50X

4219460/A 02/2014

NOTES: (continued)

5. Laser cutting apertures with trapezoidal walls and rounded corners may offer better paste release.

IMPORTANT NOTICE AND DISCLAIMER

TI PROVIDES TECHNICAL AND RELIABILITY DATA (INCLUDING DATASHEETS), DESIGN RESOURCES (INCLUDING REFERENCE DESIGNS), APPLICATION OR OTHER DESIGN ADVICE, WEB TOOLS, SAFETY INFORMATION, AND OTHER RESOURCES "AS IS" AND WITH ALL FAULTS, AND DISCLAIMS ALL WARRANTIES, EXPRESS AND IMPLIED, INCLUDING WITHOUT LIMITATION ANY IMPLIED WARRANTIES OF MERCHANTABILITY, FITNESS FOR A PARTICULAR PURPOSE OR NON-INFRINGEMENT OF THIRD PARTY INTELLECTUAL PROPERTY RIGHTS.

These resources are intended for skilled developers designing with TI products. You are solely responsible for (1) selecting the appropriate TI products for your application, (2) designing, validating and testing your application, and (3) ensuring your application meets applicable standards, and any other safety, security, or other requirements. These resources are subject to change without notice. TI grants you permission to use these resources only for development of an application that uses the TI products described in the resource. Other reproduction and display of these resources is prohibited. No license is granted to any other TI intellectual property right or to any third party intellectual property right. TI disclaims responsibility for, and you will fully indemnify TI and its representatives against, any claims, damages, costs, losses, and liabilities arising out of your use of these resources.

TI's products are provided subject to TI's Terms of Sale (www.ti.com/legal/termsofsale.html) or other applicable terms available either on ti.com or provided in conjunction with such TI products. TI's provision of these resources does not expand or otherwise alter TI's applicable warranties or warranty disclaimers for TI products.

Mailing Address: Texas Instruments, Post Office Box 655303, Dallas, Texas 75265
Copyright © 2018, Texas Instruments Incorporated

Looking for pricing, stock, or lifecycle information?

Click below to explore more details on WIN SOURCE:

 [View TMP103FYFFR](#) on WIN SOURCE

 [Texas Instruments](#) Information

Optimize Your Supply Chain with WIN SOURCE Solutions

-  Global Sourcing Solution
-  Obsolete Management
-  Cost Control Management
-  Shortage Management
-  Alternative Solution
-  Excess Inventory Management