



THE DATASHEET OF TLV3491AIDBVT



TLV349x 1.8-V, Nanopower, Push-Pull Output Comparator

1 Features

- Very Low Supply Current: 0.8 μA (Typical)
- Input Common-Mode Range: 200-mV Beyond Supply Rails
- Supply Voltage: 1.8 V to 5.5 V
- High Speed: 6 μs
- Push-Pull CMOS Output Stage
- Small Packages:
 - 5-Pin SOT-23 (Single)
 - 8-Pin SOT-23 (Dual)

2 Applications

- Portable Medical Equipment
- Wireless Security Systems
- Remote Control Systems
- Handheld Instruments
- Ultra-Low Power Systems

3 Description

The TLV349x family of push-pull output comparators features a fast 6- μs response time and $< 1.2\text{-}\mu\text{A}$ (maximum) nanopower capability, allowing operation from 1.8 V to 5.5 V. Input common-mode range beyond supply rails make the TLV349x an ideal choice for low-voltage applications.

Micro-sized packages provide options for portable and space-restricted applications. The single (TLV3491) is available in 5-pin SOT-23 and 8-pin SOIC packages. The dual (TLV3492) comes in 8-pin SOT-23 and SOIC packages. The quad (TLV3494) is available in both 14-pin TSSOP and SOIC packages.

The TLV349x is excellent for power-sensitive, low-voltage (two-cell) applications.

Device Information⁽¹⁾

PART NUMBER	PACKAGE	BODY SIZE (NOM)
TLV3491	SOT-23 (5)	2.90 mm \times 1.60 mm
	SOIC (8)	4.90 mm \times 3.91 mm
TLV3492	SOT-23 (8)	2.90 mm \times 1.63 mm
	SOIC (8)	4.90 mm \times 3.91 mm
TLV3494	SOIC (14)	8.65 mm \times 3.91 mm
	TSSOP (14)	5.00 mm \times 4.40 mm

(1) For all available packages, see the orderable addendum at the end of the data sheet.

TLV349x Basic Connections

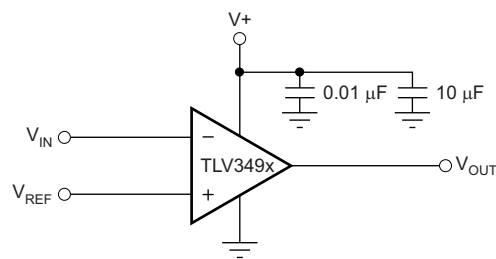

Copyright © 2016, Texas Instruments Incorporated



Table of Contents

1 Features	1	8.2 Functional Block Diagram	10
2 Applications	1	8.3 Feature Description	10
3 Description	1	8.4 Device Functional Modes	11
4 Revision History	2	9 Application and Implementation	12
5 Device Comparison Table	3	9.1 Application Information	12
6 Pin Configuration and Functions	3	9.2 Typical Applications	12
7 Specifications	5	10 Power Supply Recommendations	15
7.1 Absolute Maximum Ratings	5	11 Layout	15
7.2 ESD Ratings	5	11.1 Layout Guidelines	15
7.3 Recommended Operating Conditions	5	11.2 Layout Example	15
7.4 Thermal Information: TLV3491	5	12 Device and Documentation Support	16
7.5 Thermal Information: TLV3492	5	12.1 Device Support	16
7.6 Thermal Information: TLV3494	6	12.2 Related Links	17
7.7 Electrical Characteristics: $V_S = 1.8\text{ V to }5.5\text{ V}$	6	12.3 Community Resources	17
7.8 Switching Characteristics	6	12.4 Trademarks	17
7.9 Typical Characteristics	7	12.5 Electrostatic Discharge Caution	17
8 Detailed Description	10	12.6 Glossary	17
8.1 Overview	10	13 Mechanical, Packaging, and Orderable Information	17

4 Revision History

Changes from Revision D (April 2005) to Revision E

Page

• Added <i>ESD Ratings</i> table, <i>Feature Description</i> section, <i>Device Functional Modes</i> , <i>Application and Implementation</i> section, <i>Power Supply Recommendations</i> section, <i>Layout</i> section, <i>Device and Documentation Support</i> section, and <i>Mechanical, Packaging, and Orderable Information</i> section	1
• Changed <i>Related Products To: Device Comparison</i>	3
• Deleted <i>Package/Ordering Information</i> table; see <i>Package Option Addendum</i> at the end of the data sheet	3
• Deleted Lead temperature from <i>Absolute Maximum Ratings</i>	5
• Changed Thermal Resistance, $R_{\theta JA}$, in <i>Thermal Information: TLV3491</i> From: 200°C/W To: 237.8°C/W (SOT-23) and From: 150°C/W To: 201.9°C/W (SOIC)	5
• Changed Thermal Resistance, $R_{\theta JA}$, in <i>Thermal Information: TLV3492</i> From: 200°C/W To: 135.4°C/W (SOT-23) and From: 150°C/W To: 201.9°C/W (SOIC)	5
• Changed Thermal Resistance, $R_{\theta JA}$, in <i>Thermal Information: TLV3494</i> From: 100°C/W To: 83.8°C/W (SOIC) and From: 100°C/W To: 120.8°C/W (TSSOP)	6

5 Device Comparison Table

PRODUCT	FEATURES
TLV370x	560-nA, 2.5-V to 16-V, push-pull CMOS output stage comparators
TLV340x	550-nA, 2.5-V to 16-V, open-drain output stage comparators

6 Pin Configuration and Functions

**TLV3491 DBV Package
5-Pin SOT-23
Top View**

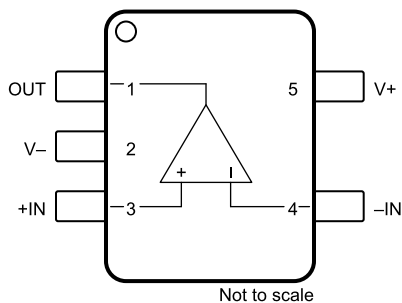

**TLV3491 D Package
8-Pin SOIC
Top View**

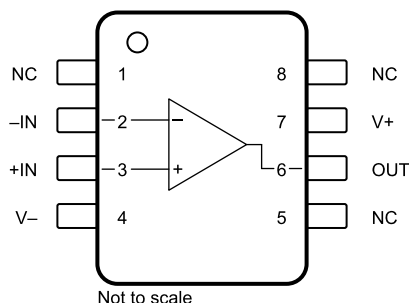

Pin Functions: TLV3491

NAME	PIN		I/O	DESCRIPTION
	SOT-23	SOIC		
-IN	4	2	I	Inverting input
+IN	3	3	I	Noninverting input
NC	—	1, 5, 8	—	No internal connection (can be left floating)
OUT	1	6	O	Output
V+	5	7	—	Positive (highest) power supply
V-	2	4	—	Negative (lowest) power supply

**TLV3492 DCN and D Packages
8-Pin SOT-23 and SOIC
Top View**

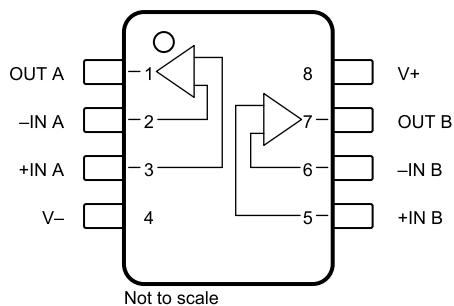

Pin Functions: TLV3492

PIN		I/O	DESCRIPTION
NAME	NO.		
-IN A	2	I	Inverting input, channel A
-IN B	6	I	Inverting input, channel B
+IN A	3	I	Noninverting input, channel A
+IN B	5	I	Noninverting input, channel B
OUT A	1	O	Output, channel A
OUT B	7	O	Output, channel B
V-	4	—	Negative (lowest) power supply
V+	8	—	Positive (highest) power supply

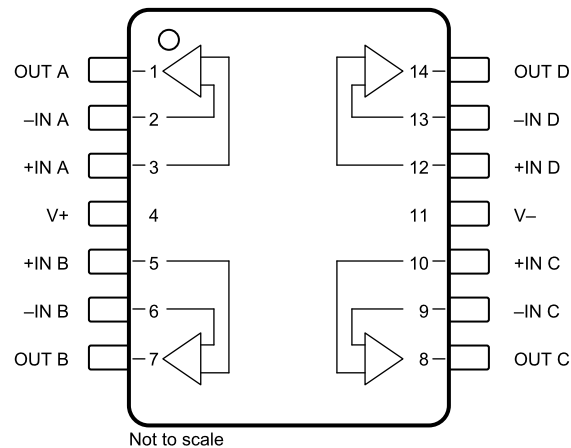
**TLV3494 D and PW Packages
14-Pin SOIC and TSSOP
Top View**

Pin Functions: TLV3494

PIN		I/O	DESCRIPTION
NAME	NO.		
-In A	2	I	Inverting input, channel A
-In B	6	I	Inverting input, channel B
-In C	9	I	Inverting input, channel C
-In D	13	I	Inverting input, channel D
+In A	3	I	Noninverting input, channel A
+In B	5	I	Noninverting input, channel B
+In C	10	I	Noninverting input, channel C
+In D	12	I	Noninverting input, channel D
Out A	1	O	Output, channel A
Out B	7	O	Output, channel B
Out C	8	O	Output, channel C
Out D	14	O	Output, channel D
V-	11	—	Negative (lowest) power supply
V+	4	—	Positive (highest) power supply

7 Specifications

7.1 Absolute Maximum Ratings

over operating free-air temperature range (unless otherwise noted)⁽¹⁾

		MIN	MAX	UNIT
Voltage	Supply	5.5		V
	Signal input pin	(V ₋) - 0.5	(V ₊) + 0.5	V
Current	Signal input pin	-10	10	mA
	Output short circuit	Continuous		
Temperature	Operating, T _A	-40	125	°C
	Junction, T _J	150		°C
	Storage, T _{stg}	-65	150	°C

- (1) Stresses beyond those listed under *Absolute Maximum Ratings* may cause permanent damage to the device. These are stress ratings only, which do not imply functional operation of the device at these or any other conditions beyond those indicated under *Recommended Operating Conditions*. Exposure to absolute-maximum-rated conditions for extended periods may affect device reliability.

7.2 ESD Ratings

			VALUE	UNIT
V _(ESD)	Electrostatic discharge	Human-body model (HBM), per ANSI/ESDA/JEDEC JS-001 ⁽¹⁾	±3000	V

- (1) JEDEC document JEP155 states that 500-V HBM allows safe manufacturing with a standard ESD control process.

7.3 Recommended Operating Conditions

over operating free-air temperature range (unless otherwise noted)

		MIN	MAX	UNIT
	Supply voltage	1.8	5.5	V
T _A	Specified temperature	-40	125	°C

7.4 Thermal Information: TLV3491

THERMAL METRIC ⁽¹⁾		TLV3491		UNIT
		DBV (SOT-23)	D (SOIC)	
		5 PINS	8 PINS	
R _{θJA}	Junction-to-ambient thermal resistance	237.8	201.9	°C/W
R _{θJC(top)}	Junction-to-case (top) thermal resistance	108.7	92.5	°C/W
R _{θJB}	Junction-to-board thermal resistance	64.1	123.3	°C/W
ψ _{JT}	Junction-to-top characterization parameter	12.1	23	°C/W
ψ _{JB}	Junction-to-board characterization parameter	63.3	212.6	°C/W
R _{θJC(bot)}	Junction-to-case (bottom) thermal resistance	—	—	°C/W

- (1) For more information about traditional and new thermal metrics, see the *Semiconductor and IC Package Thermal Metrics* application report.

7.5 Thermal Information: TLV3492

THERMAL METRIC ⁽¹⁾		TLV3492		UNIT
		DCN (SOT-23)	D (SOIC)	
		8 PINS	8 PINS	
R _{θJA}	Junction-to-ambient thermal resistance	135.4	201.9	°C/W
R _{θJC(top)}	Junction-to-case (top) thermal resistance	68.1	92.5	°C/W
R _{θJB}	Junction-to-board thermal resistance	48.9	123.3	°C/W
ψ _{JT}	Junction-to-top characterization parameter	9.9	23	°C/W
ψ _{JB}	Junction-to-board characterization parameter	48.4	212.6	°C/W
R _{θJC(bot)}	Junction-to-case (bottom) thermal resistance	—	—	°C/W

- (1) For more information about traditional and new thermal metrics, see the *Semiconductor and IC Package Thermal Metrics* application report.

7.6 Thermal Information: TLV3494

THERMAL METRIC ⁽¹⁾		TLV3494		UNIT
		D (SOIC)	PW (TSSOP)	
		14 PINS	14 PINS	
R _{θJA}	Junction-to-ambient thermal resistance	83.8	120.8	°C/W
R _{θJC(top)}	Junction-to-case (top) thermal resistance	70.7	34.3	°C/W
R _{θJB}	Junction-to-board thermal resistance	59.5	62.8	°C/W
ψ _{JT}	Junction-to-top characterization parameter	11.6	1	°C/W
ψ _{JB}	Junction-to-board characterization parameter	37.7	56.5	°C/W
R _{θJC(bot)}	Junction-to-case (bottom) thermal resistance	—	—	°C/W

- (1) For more information about traditional and new thermal metrics, see the [Semiconductor and IC Package Thermal Metrics](#) application report.

7.7 Electrical Characteristics: V_S = 1.8 V to 5.5 V

at T_A = 25°C and V_S = 1.8 V to 5.5 V (unless otherwise noted)

PARAMETER		TEST CONDITIONS	MIN	TYP	MAX	UNIT
OFFSET VOLTAGE						
V _{OS}	Input offset voltage	T _A = 25°C, V _{CM} = 0 V, I _O = 0 V		±3	±15	mV
dV _{OS} /dT	Input offset voltage versus temperature	T _A = –40°C to 125°C		±12		μV/°C
PSRR	Input offset voltage versus power supply	V _S = 1.8 V to 5.5 V		350	1000	μV/V
INPUT BIAS CURRENT						
I _B	Input bias current	V _{CM} = V _{CC} /2		±1	±10	pA
I _{OS}	Input offset current	V _{CM} = V _{CC} /2		±1	±10	pA
INPUT VOLTAGE						
V _{CM}	Common-mode voltage		(V–) – 0.2 V		(V+) + 0.2 V	V
CMRR	Common-mode rejection ratio	V _{CM} = –0.2 V to (V+) – 1.5 V	60	74		dB
		V _{CM} = –0.2 V to (V+) + 0.2 V	54	62		
INPUT CAPACITANCE						
	Common-mode			2		pF
	Differential			4		pF
OUTPUT (V_S = 5 V)						
V _{OH}	Voltage output high from rail	I _{OUT} = 5 mA		90	200	mV
V _{OL}	Voltage output low from rail	I _{OUT} = 5 mA		160	200	mV
I _{SC}	Short-circuit current		See Typical Characteristics			
POWER SUPPLY						
V _S	Specified voltage		1.8		5.5	V
	Operating voltage		1.8		5.5	V
I _Q	Quiescent current ⁽¹⁾	V _O = 5 V, V _O = high		0.85	1.2	μA

- (1) I_Q per channel

7.8 Switching Characteristics

at f = 10 kHz, V_{STEP} = 1 V, T_A = 25°C, and V_S = 1.8 V to 5.5 V (unless otherwise noted)

PARAMETER		TEST CONDITIONS	MIN	TYP	MAX	UNIT
t _(PLH)	Propagation delay time, low-to-high	Input overdrive = 10 mV		12		μs
		Input overdrive = 100 mV		6		
t _(PLH)	Propagation delay time, high-to-low	Input overdrive = 10 mV		13.5		μs
		Input overdrive = 100 mV		6.5		
t _R	Rise time	C _L = 10 pF		100		ns
t _F	Fall time	C _L = 10 pF		100		ns

7.9 Typical Characteristics

at $T_A = 25^\circ\text{C}$, $V_S = 1.8\text{ V to }5.5\text{ V}$, and input overdrive = 100 mV (unless otherwise noted)

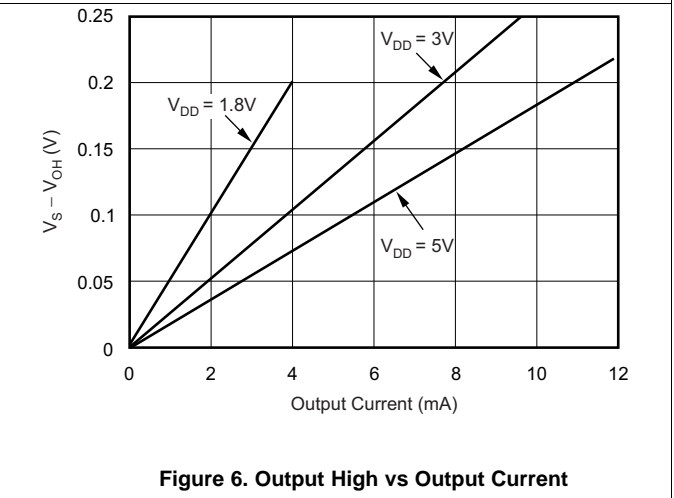
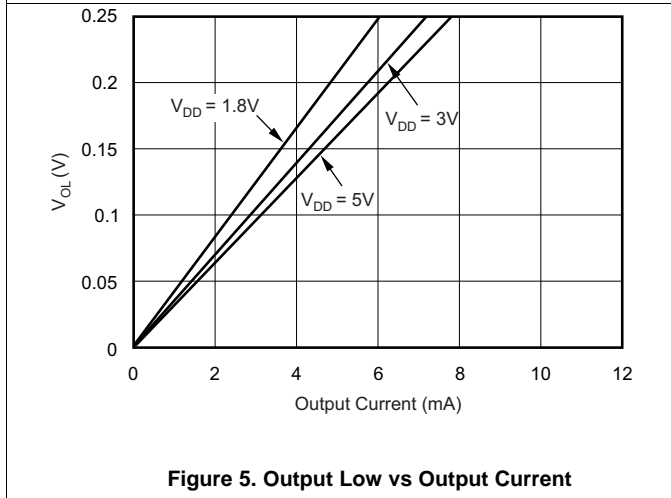
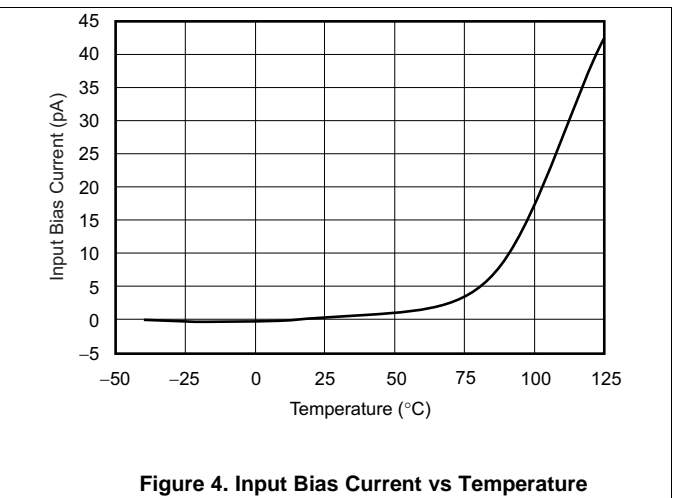
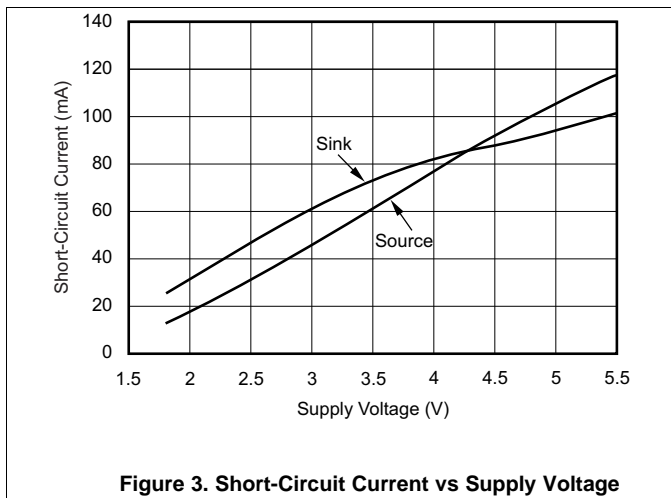
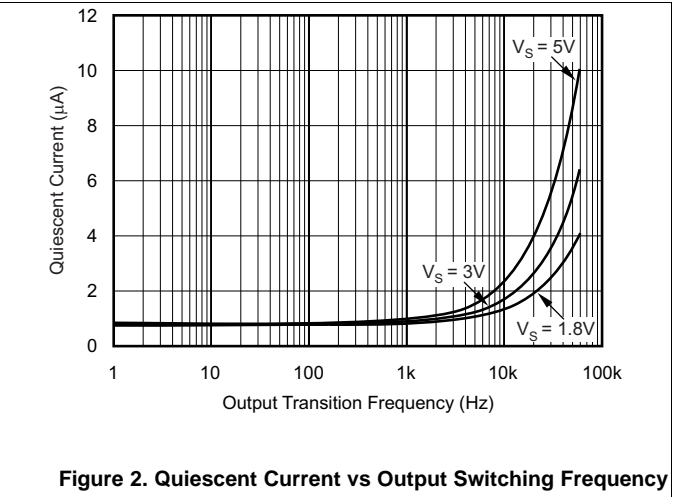
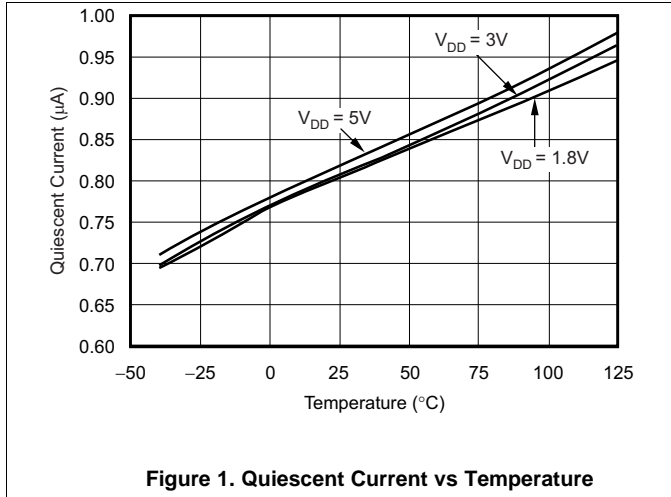

Typical Characteristics (continued)

at $T_A = 25^\circ\text{C}$, $V_S = 1.8\text{ V to }5.5\text{ V}$, and input overdrive = 100 mV (unless otherwise noted)

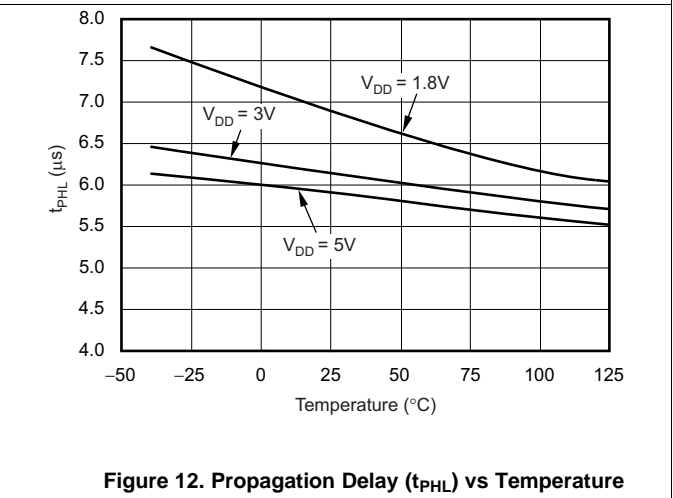
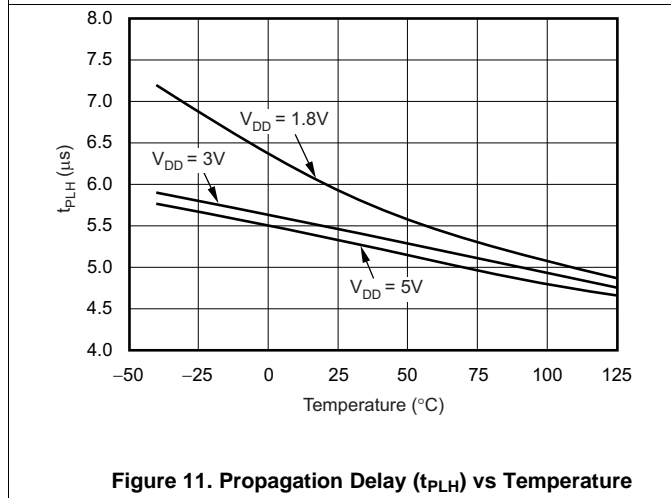
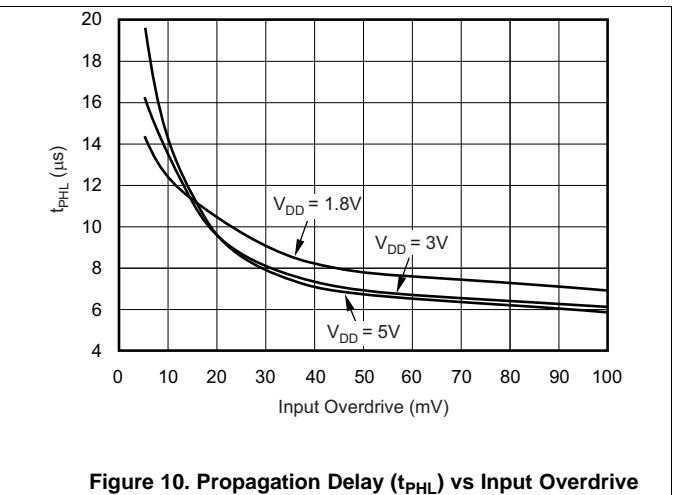
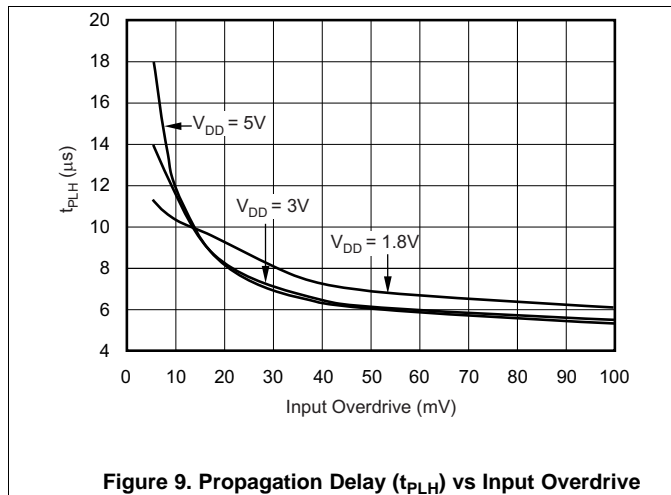
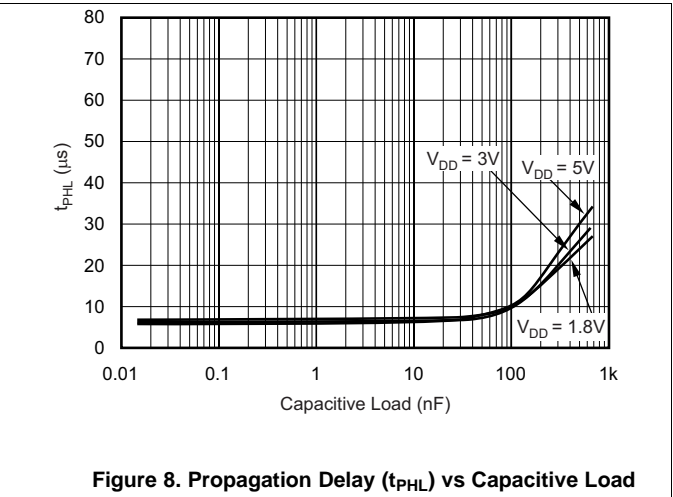
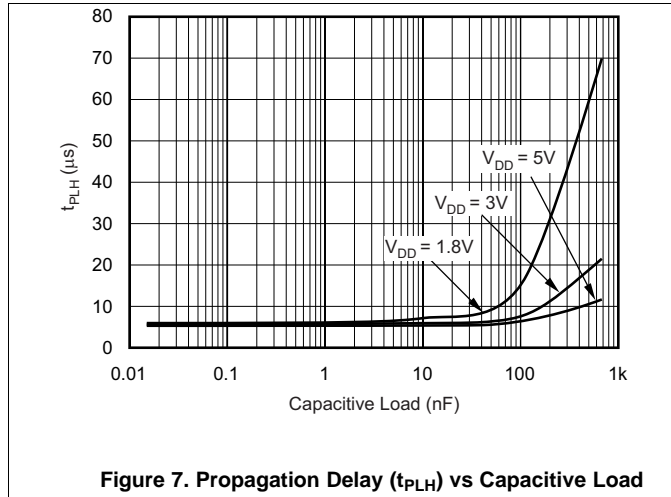

Typical Characteristics (continued)

at $T_A = 25^\circ\text{C}$, $V_S = 1.8\text{ V to }5.5\text{ V}$, and input overdrive = 100 mV (unless otherwise noted)

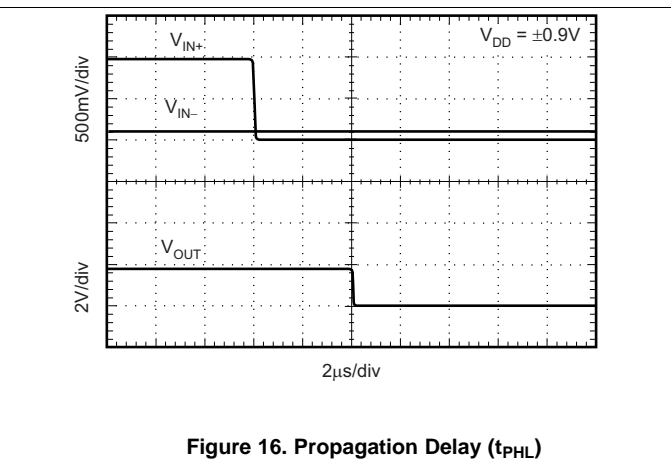
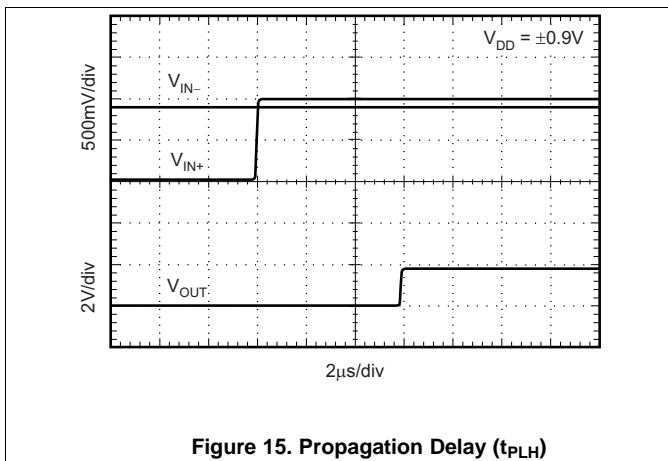
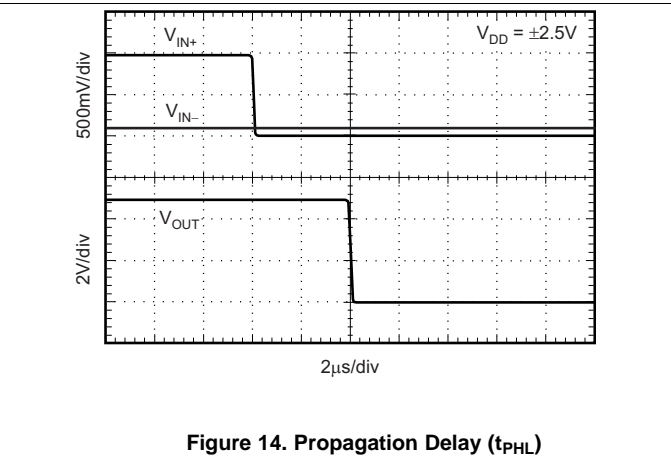
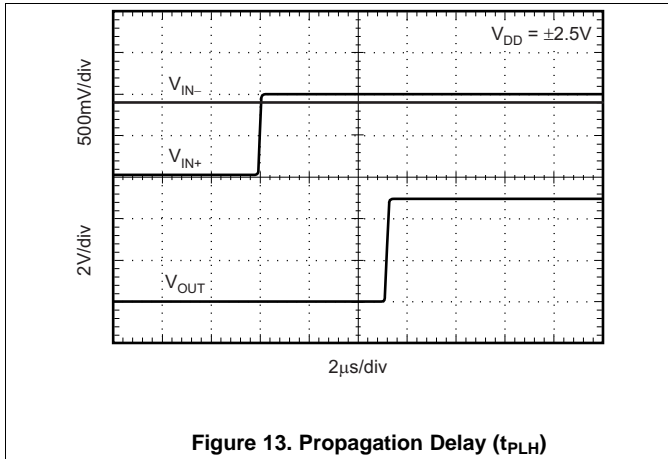

8 Detailed Description

8.1 Overview

The TLV349x family of comparators features rail-to-rail input and output on supply voltages as low as 1.8 V. The push-pull output stage is optimal for reduced power budget applications and features no shoot-through current. Low supply voltages, common-mode input range beyond supply rails, and a typical supply current of 0.8 μA make the TLV349x family an excellent candidate for battery-powered applications with single-cell operation as well as a wide range of low-voltage applications. The devices are available in a selection of micro-sized packages for space-constrained and portable applications.

8.2 Functional Block Diagram

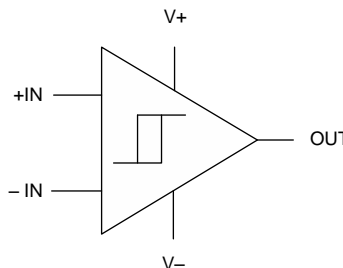

Copyright © 2016, Texas Instruments Incorporated

8.3 Feature Description

8.3.1 Operating Voltage

The TLV349x comparators are specified for use on a single supply from 1.8 V to 5.5 V (or a dual supply from ± 0.9 V to ± 2.75 V) over a temperature range of -40°C to 125°C .

8.3.2 Input Overvoltage Protection

The device inputs are protected by electrostatic discharge (ESD) diodes that conduct if the input voltages exceed the power supplies by more than approximately 500 mV. Momentary voltages greater than 500 mV beyond the power supply can be tolerated if the input current is limited to 10 mA. This limiting is easily accomplished with a small input resistor in series with the input to the comparator.

8.3.3 Setting Reference Voltage

It is important to use a stable reference when setting the transition point for the TLV349x. The REF1004 provides a 1.25-V reference voltage with low drift and only 8 μA of quiescent current.

8.3.4 External Hysteresis

Comparator inputs have no noise immunity within the range of specified offset voltage (± 15 mV). For noisy input signals, the comparator output typically displays multiple switching as input signals move through the switching threshold. The typical comparator threshold of the TLV349x is ± 15 mV. To prevent multiple switching within the comparator threshold of the TLV349x, external hysteresis must be added by connecting a small amount of feedback to the positive input. [Figure 17](#) shows a typical topology used to introduce hysteresis, described in [Equation 1](#).

$$V_{\text{HYST}} = \frac{V^+ \times R_1}{R_1 + R_2} \quad (1)$$

V_{HYST} sets the value of the transition voltage required to switch the comparator output by increasing the threshold region, thereby reducing sensitivity to noise.

Feature Description (continued)

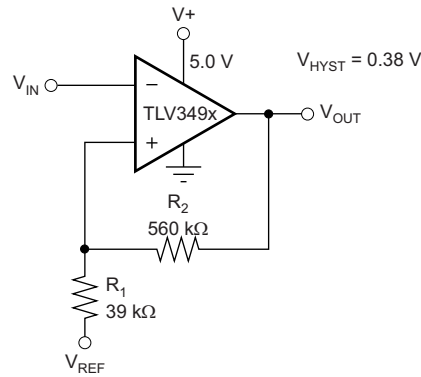

Copyright © 2016, Texas Instruments Incorporated

Figure 17. Adding Hysteresis to the TLV349x

8.4 Device Functional Modes

The TLV349x has a single functional mode and is operational when the power-supply voltage is between 1.8 V and 5.5 V.

9 Application and Implementation

NOTE

Information in the following applications sections is not part of the TI component specification, and TI does not warrant its accuracy or completeness. TI's customers are responsible for determining suitability of components for their purposes. Customers should validate and test their design implementation to confirm system functionality.

9.1 Application Information

The TLV349x family of comparators features rail-to-rail input and output on supply voltages as low as 1.8 V. The push-pull output stage is optimal for reduced power budget applications and features no shoot-through current. Low supply voltages, common-mode input range beyond supply rails, and a typical supply current of 0.8 μ A make the TLV349x family an excellent candidate for battery-powered applications with single-cell operation.

9.2 Typical Applications

9.2.1 TLV3491 Configured as an AC-Coupled Comparator

One of the benefits of AC coupling a single-supply comparator circuit is that it can block dc offsets induced by ground-loop offsets that could potentially produce either a false trip or a common-mode input violation. [Figure 18](#) shows the TLV3491 configured as an AC-coupled comparator.

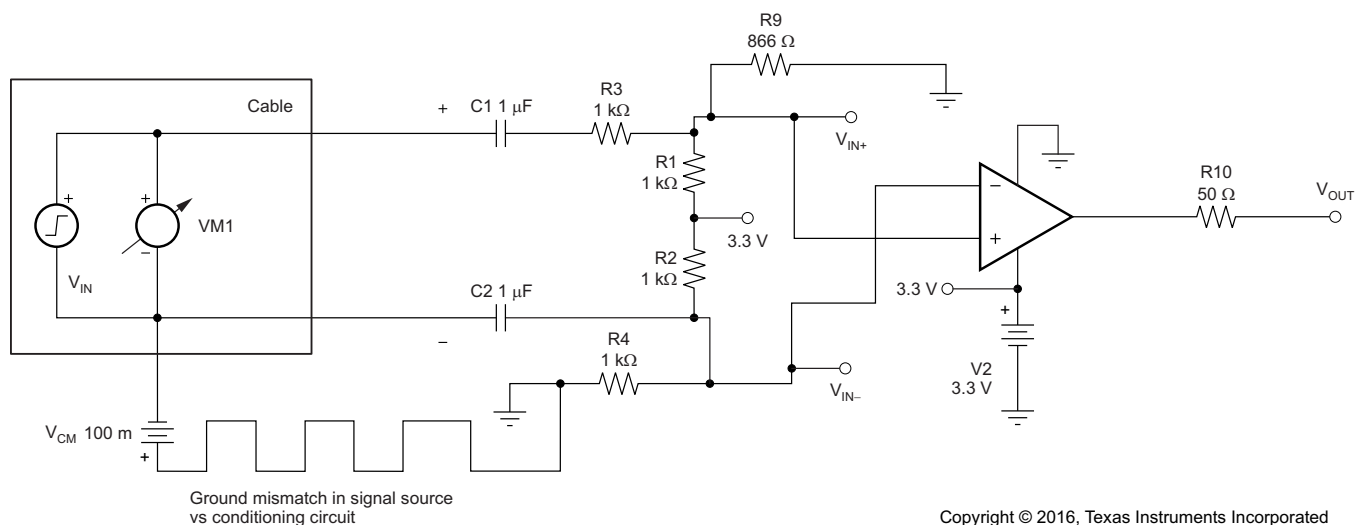

Figure 18. TLV3491 Configured as an AC-Coupled Comparator (Schematic)

9.2.1.1 Design Requirements

Design requirements include:

1. Ability to tolerate up to ± 100 mV of common-mode signal.
2. Trigger only on AC signals (such as zero-cross detection).

Typical Applications (continued)

9.2.1.2 Detailed Design Procedure

Design analysis:

- AC-coupled, high-pass frequency
 - Large capacitors require longer start-up time from device power on
 - Use 1- μ F capacitor to achieve high-pass frequency of approximately 159 Hz
 - For high-pass equivalent, use $C_{IN} = 0.5 \mu\text{F}$, $R_{IN} = 2 \text{ k}\Omega$
1. Set up input dividers initially for one-half supply (to be in center of acceptable common-mode range).
 2. Adjust either divider slightly upwards or downwards as desired to establish quiescent output condition.
 3. Select coupling capacitors based on lowest expected frequency.

9.2.1.3 Application Curve

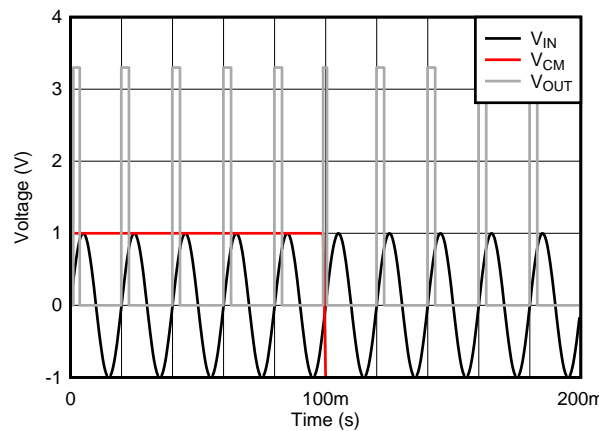

Figure 19. AC-Coupled Comparator Results

9.2.2 Relaxation Oscillator

The TLV349x can be configured as a relaxation oscillator to provide a simple and inexpensive clock output, as Figure 20 shows. The capacitor is charged at a rate of 0.69 RC . It also discharges at a rate of 0.69 RC . Therefore, the period is 1.38 RC . R_1 may be a different value than R_2 .

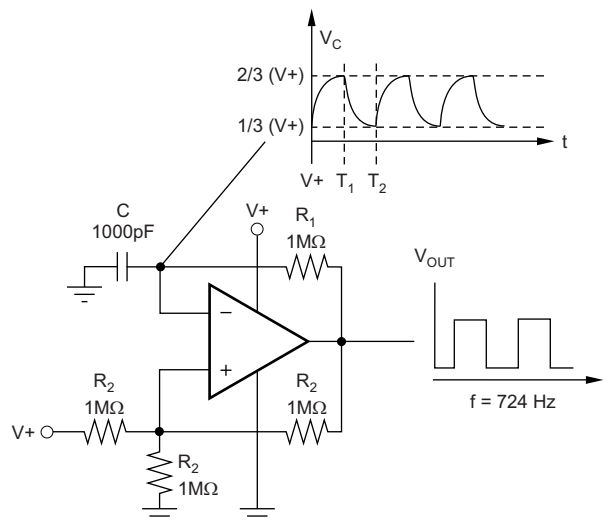

Figure 20. TLV349x Configured as a Relaxation Oscillator

Typical Applications (continued)

9.2.3 Power-On Reset

The reset circuit shown in [Figure 21](#) provides a time-delayed release of reset to the MSP430 microcontroller. Operation of the circuit is based on a stabilization time constant of the supply voltage, rather than on a predetermined voltage value. The negative input is a reference voltage created by a simple resistor divider.

These resistor values must be relatively high to reduce the current consumption of the circuit. The positive input is an RC circuit that provides a power-up delay. When power is applied, the output of the comparator is low, holding the processor in the reset condition. Only after allowing time for the supply voltage to stabilize does the positive input of the comparator become higher than the negative input, resulting in a high output state and releasing the processor for operation. The stabilization time required for the supply voltage is adjustable by the selection of the RC component values.

Use of a lower-valued resistor in this portion of the circuit does not increase current consumption because no current flows through the RC circuit after the supply has stabilized. The required reset delay time depends on the power-up characteristics of the system power supply. R_1 and C_1 are selected to allow enough time for the power supply to stabilize. D_1 provides rapid reset if power is lost. In this example, the $R_1 \times C_1$ time constant is 10 ms.

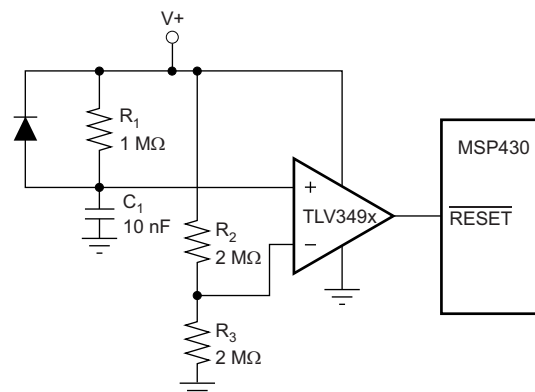

Copyright © 2016, Texas Instruments Incorporated

Figure 21. The TLV349x Configured as a Reset Circuit for the MSP430

10 Power Supply Recommendations

The TLV349x family of devices is specified for operation from 1.8 V to 5.5 V (± 0.9 V to ± 2.75 V). Parameters that can exhibit significant variance with regard to operating voltage are presented in [Typical Characteristics](#).

11 Layout

11.1 Layout Guidelines

Figure 22 shows the typical connections for the TLV349x. To minimize supply noise, power supplies must be capacitively decoupled by a 0.01- μ F ceramic capacitor in parallel with a 10- μ F electrolytic capacitor. Comparators are very sensitive to input noise. Proper grounding (the use of a ground plane) helps to maintain the specified performance of the TLV349x family.

For best results, maintain the following layout guidelines:

1. Use a printed-circuit board (PCB) with a good, unbroken low-inductance ground plane.
2. Place a decoupling capacitor (0.1- μ F ceramic, surface-mount capacitor) as close as possible to V_{CC} .
3. On the inputs and the output, keep lead lengths as short as possible to avoid unwanted parasitic feedback around the comparator. Keep inputs away from the output.
4. Solder the device directly to the PCB rather than using a socket.
5. For slow-moving input signals, take care to prevent parasitic feedback. A small capacitor (1000 pF or less) placed between the inputs can help eliminate oscillations in the transition region. This capacitor causes some degradation to propagation delay when the impedance is low. The topside ground plane runs between the output and inputs.
6. The ground pin ground trace runs under the device up to the bypass capacitor, shielding the inputs from the outputs.

11.2 Layout Example

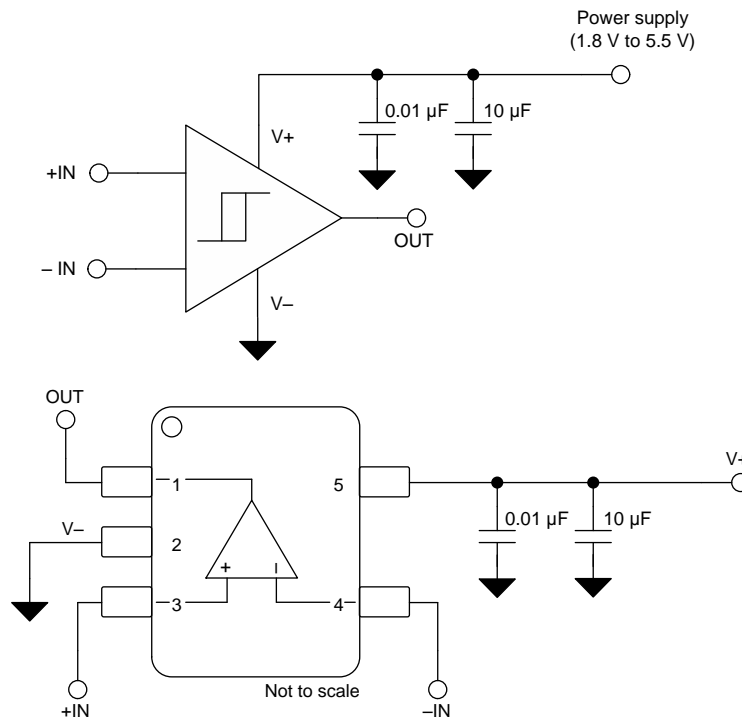

Copyright © 2016, Texas Instruments Incorporated

Figure 22. Basic Connections of the TLV349x

12 Device and Documentation Support

12.1 Device Support

12.1.1 Development Support

12.1.1.1 TINA-TI™ (Free Software Download)

TINA™ is a simple, powerful, and easy-to-use circuit simulation program based on a SPICE engine. TINA-TI™ is a free, fully-functional version of the TINA software, preloaded with a library of macro models in addition to a range of both passive and active models. TINA-TI provides all the conventional dc, transient, and frequency domain analysis of SPICE, as well as additional design capabilities.

Available as a [free download](#) from the Analog eLab Design Center, TINA-TI offers extensive post-processing capability that allows users to format results in a variety of ways. Virtual instruments offer the ability to select input waveforms and probe circuit nodes, voltages, and waveforms, creating a dynamic quick-start tool.

NOTE

These files require that either the TINA software (from DesignSoft™) or TINA-TI software be installed. Download the free TINA-TI software from the [TINA-TI folder](#).

12.1.1.2 DIP Adapter EVM

The [DIP Adapter EVM](#) tool provides an easy, low-cost way to prototype small surface mount ICs. The evaluation tool these TI packages: D or U (SOIC-8), PW (TSSOP-8), DGK (MSOP-8), DBV (SOT23-6, SOT23-5 and SOT23-3), DCK (SC70-6 and SC70-5), and DRL (SOT563-6). The DIP Adapter EVM may also be used with terminal strips or may be wired directly to existing circuits.

12.1.1.3 Universal Op Amp EVM

The [Universal Op Amp EVM](#) is a series of general-purpose, blank circuit boards that simplify prototyping circuits for a variety of IC package types. The evaluation module board design allows many different circuits to be constructed easily and quickly. Five models are offered, with each model intended for a specific package type. PDIP, SOIC, MSOP, TSSOP and SOT23 packages are all supported.

NOTE

These boards are unpopulated, so users must provide their own ICs. TI recommends requesting several op amp device samples when ordering the Universal Op Amp EVM.

12.1.1.4 TI Precision Designs

TI Precision Designs are analog solutions created by TI's precision analog applications experts and offer the theory of operation, component selection, simulation, complete PCB schematic and layout, bill of materials, and measured performance of many useful circuits. TI Precision Designs are available online at <http://www.ti.com/ww/en/analog/precision-designs/>.

12.1.1.5 WEBENCH® Filter Designer

[WEBENCH® Filter Designer](#) is a simple, powerful, and easy-to-use active filter design program. The WEBENCH Filter Designer lets you create optimized filter designs using a selection of TI operational amplifiers and passive components from TI's vendor partners.

Available as a web-based tool from the WEBENCH® Design Center, [WEBENCH® Filter Designer](#) allows you to design, optimize, and simulate complete multistage active filter solutions within minutes.

12.2 Related Links

Table 1 lists quick access links. Categories include technical documents, support and community resources, tools and software, and quick access to sample or buy.

Table 1. Related Links

PARTS	PRODUCT FOLDER	SAMPLE & BUY	TECHNICAL DOCUMENTS	TOOLS & SOFTWARE	SUPPORT & COMMUNITY
TLV3491	Click here	Click here	Click here	Click here	Click here
TLV3492	Click here	Click here	Click here	Click here	Click here
TLV3494	Click here	Click here	Click here	Click here	Click here

12.3 Community Resources

The following links connect to TI community resources. Linked contents are provided "AS IS" by the respective contributors. They do not constitute TI specifications and do not necessarily reflect TI's views; see TI's [Terms of Use](#).

TI E2E™ Online Community *TI's Engineer-to-Engineer (E2E) Community*. Created to foster collaboration among engineers. At e2e.ti.com, you can ask questions, share knowledge, explore ideas and help solve problems with fellow engineers.

Design Support *TI's Design Support* Quickly find helpful E2E forums along with design support tools and contact information for technical support.

12.4 Trademarks

TINA-TI, E2E are trademarks of Texas Instruments.
 WEBENCH is a registered trademark of Texas Instruments.
 TINA, DesignSoft are trademarks of DesignSoft, Inc.
 All other trademarks are the property of their respective owners.

12.5 Electrostatic Discharge Caution



These devices have limited built-in ESD protection. The leads should be shorted together or the device placed in conductive foam during storage or handling to prevent electrostatic damage to the MOS gates.

12.6 Glossary

[SLYZ022](#) — *TI Glossary*.

This glossary lists and explains terms, acronyms, and definitions.

13 Mechanical, Packaging, and Orderable Information

The following pages include mechanical, packaging, and orderable information. This information is the most current data available for the designated devices. This data is subject to change without notice and revision of this document. For browser-based versions of this data sheet, refer to the left-hand navigation.

PACKAGING INFORMATION

Orderable Device	Status (1)	Package Type	Package Drawing	Pins	Package Qty	Eco Plan (2)	Lead/Ball Finish (6)	MSL Peak Temp (3)	Op Temp (°C)	Device Marking (4/5)	Samples
TLV3491AID	ACTIVE	SOIC	D	8	75	Green (RoHS & no Sb/Br)	CU NIPDAU	Level-2-260C-1 YEAR	-40 to 125	TLV 3491	Samples
TLV3491AIDBVR	ACTIVE	SOT-23	DBV	5	3000	Green (RoHS & no Sb/Br)	CU NIPDAU	Level-2-260C-1 YEAR	-40 to 125	VBNI	Samples
TLV3491AIDBVRG4	ACTIVE	SOT-23	DBV	5	3000	Green (RoHS & no Sb/Br)	CU NIPDAU	Level-2-260C-1 YEAR	-40 to 125	VBNI	Samples
TLV3491AIDBVT	ACTIVE	SOT-23	DBV	5	250	Green (RoHS & no Sb/Br)	CU NIPDAU	Level-2-260C-1 YEAR	-40 to 125	VBNI	Samples
TLV3491AIDBVTG4	ACTIVE	SOT-23	DBV	5	250	Green (RoHS & no Sb/Br)	CU NIPDAU	Level-2-260C-1 YEAR	-40 to 125	VBNI	Samples
TLV3491AIDG4	ACTIVE	SOIC	D	8	75	Green (RoHS & no Sb/Br)	CU NIPDAU	Level-2-260C-1 YEAR	-40 to 125	TLV 3491	Samples
TLV3491AIDR	ACTIVE	SOIC	D	8	2500	Green (RoHS & no Sb/Br)	CU NIPDAU	Level-2-260C-1 YEAR	-40 to 125	TLV 3491	Samples
TLV3492AID	ACTIVE	SOIC	D	8	75	Green (RoHS & no Sb/Br)	CU NIPDAU	Level-2-260C-1 YEAR	-40 to 125	TLV 3492	Samples
TLV3492AIDCNR	ACTIVE	SOT-23	DCN	8	3000	Green (RoHS & no Sb/Br)	CU NIPDAU	Level-1-260C-UNLIM	-40 to 125	VBO1	Samples
TLV3492AIDCNT	ACTIVE	SOT-23	DCN	8	250	Green (RoHS & no Sb/Br)	CU NIPDAU	Level-1-260C-UNLIM	-40 to 125	VBO1	Samples
TLV3492AIDR	ACTIVE	SOIC	D	8	2500	Green (RoHS & no Sb/Br)	CU NIPDAU	Level-2-260C-1 YEAR	-40 to 125	TLV 3492	Samples
TLV3494AID	ACTIVE	SOIC	D	14	50	Green (RoHS & no Sb/Br)	CU NIPDAU	Level-2-260C-1 YEAR	-40 to 125	TLV3494	Samples
TLV3494AIPWR	ACTIVE	TSSOP	PW	14	2500	Green (RoHS & no Sb/Br)	CU NIPDAU	Level-2-260C-1 YEAR	-40 to 125	TLV 3494	Samples
TLV3494AIPWT	ACTIVE	TSSOP	PW	14	250	Green (RoHS & no Sb/Br)	CU NIPDAU	Level-2-260C-1 YEAR	-40 to 125	TLV 3494	Samples

(1) The marketing status values are defined as follows:

ACTIVE: Product device recommended for new designs.

LIFEBUY: TI has announced that the device will be discontinued, and a lifetime-buy period is in effect.

NRND: Not recommended for new designs. Device is in production to support existing customers, but TI does not recommend using this part in a new design.

PREVIEW: Device has been announced but is not in production. Samples may or may not be available.

OBSELETE: TI has discontinued the production of the device.

⁽²⁾ **RoHS:** TI defines "RoHS" to mean semiconductor products that are compliant with the current EU RoHS requirements for all 10 RoHS substances, including the requirement that RoHS substance do not exceed 0.1% by weight in homogeneous materials. Where designed to be soldered at high temperatures, "RoHS" products are suitable for use in specified lead-free processes. TI may reference these types of products as "Pb-Free".

RoHS Exempt: TI defines "RoHS Exempt" to mean products that contain lead but are compliant with EU RoHS pursuant to a specific EU RoHS exemption.

Green: TI defines "Green" to mean the content of Chlorine (Cl) and Bromine (Br) based flame retardants meet JS709B low halogen requirements of ≤ 1000 ppm threshold. Antimony trioxide based flame retardants must also meet the ≤ 1000 ppm threshold requirement.

⁽³⁾ MSL, Peak Temp. - The Moisture Sensitivity Level rating according to the JEDEC industry standard classifications, and peak solder temperature.

⁽⁴⁾ There may be additional marking, which relates to the logo, the lot trace code information, or the environmental category on the device.

⁽⁵⁾ Multiple Device Markings will be inside parentheses. Only one Device Marking contained in parentheses and separated by a "-" will appear on a device. If a line is indented then it is a continuation of the previous line and the two combined represent the entire Device Marking for that device.

⁽⁶⁾ Lead/Ball Finish - Orderable Devices may have multiple material finish options. Finish options are separated by a vertical ruled line. Lead/Ball Finish values may wrap to two lines if the finish value exceeds the maximum column width.

Important Information and Disclaimer: The information provided on this page represents TI's knowledge and belief as of the date that it is provided. TI bases its knowledge and belief on information provided by third parties, and makes no representation or warranty as to the accuracy of such information. Efforts are underway to better integrate information from third parties. TI has taken and continues to take reasonable steps to provide representative and accurate information but may not have conducted destructive testing or chemical analysis on incoming materials and chemicals. TI and TI suppliers consider certain information to be proprietary, and thus CAS numbers and other limited information may not be available for release.

In no event shall TI's liability arising out of such information exceed the total purchase price of the TI part(s) at issue in this document sold by TI to Customer on an annual basis.

TAPE AND REEL INFORMATION

QUADRANT ASSIGNMENTS FOR PIN 1 ORIENTATION IN TAPE

*All dimensions are nominal

Device	Package Type	Package Drawing	Pins	SPQ	Reel Diameter (mm)	Reel Width W1 (mm)	A0 (mm)	B0 (mm)	K0 (mm)	P1 (mm)	W (mm)	Pin1 Quadrant
TLV3491AIDBVR	SOT-23	DBV	5	3000	178.0	9.0	3.3	3.2	1.4	4.0	8.0	Q3
TLV3491AIDBVT	SOT-23	DBV	5	250	178.0	9.0	3.3	3.2	1.4	4.0	8.0	Q3
TLV3491AIDR	SOIC	D	8	2500	330.0	12.4	6.4	5.2	2.1	8.0	12.0	Q1
TLV3492AIDR	SOIC	D	8	2500	330.0	12.4	6.4	5.2	2.1	8.0	12.0	Q1
TLV3494AIPWR	TSSOP	PW	14	2500	330.0	12.4	6.9	5.6	1.6	8.0	12.0	Q1
TLV3494AIPWT	TSSOP	PW	14	250	180.0	12.4	6.9	5.6	1.6	8.0	12.0	Q1

TAPE AND REEL BOX DIMENSIONS

*All dimensions are nominal

Device	Package Type	Package Drawing	Pins	SPQ	Length (mm)	Width (mm)	Height (mm)
TLV3491AIDBVR	SOT-23	DBV	5	3000	180.0	180.0	18.0
TLV3491AIDBVT	SOT-23	DBV	5	250	180.0	180.0	18.0
TLV3491AIDR	SOIC	D	8	2500	367.0	367.0	35.0
TLV3492AIDR	SOIC	D	8	2500	367.0	367.0	35.0
TLV3494AIPWR	TSSOP	PW	14	2500	367.0	367.0	35.0
TLV3494AIPWT	TSSOP	PW	14	250	210.0	185.0	35.0

EXAMPLE BOARD LAYOUT

DBV0005A

SOT-23 - 1.45 mm max height

SMALL OUTLINE TRANSISTOR



LAND PATTERN EXAMPLE
EXPOSED METAL SHOWN
SCALE:15X



SOLDER MASK DETAILS

4214839/D 11/2018

NOTES: (continued)

- 5. Publication IPC-7351 may have alternate designs.
- 6. Solder mask tolerances between and around signal pads can vary based on board fabrication site.

EXAMPLE STENCIL DESIGN

DBV0005A

SOT-23 - 1.45 mm max height

SMALL OUTLINE TRANSISTOR



SOLDER PASTE EXAMPLE
BASED ON 0.125 mm THICK STENCIL
SCALE:15X

4214839/D 11/2018

NOTES: (continued)

7. Laser cutting apertures with trapezoidal walls and rounded corners may offer better paste release. IPC-7525 may have alternate design recommendations.
8. Board assembly site may have different recommendations for stencil design.

DCN (R-PDSO-G8)

PLASTIC SMALL-OUTLINE PACKAGE (DIE DOWN)

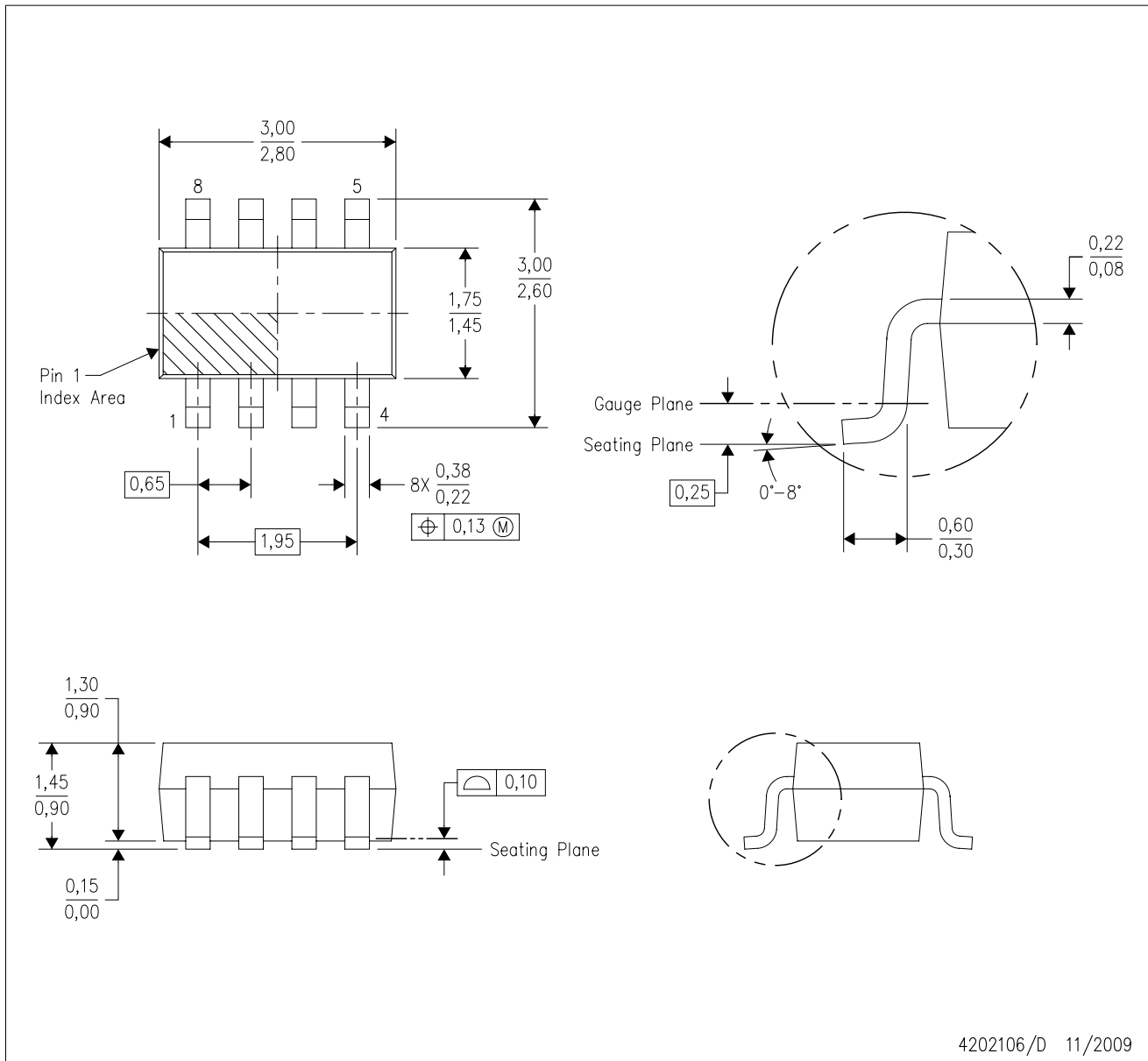

4202106/D 11/2009

- NOTES:
- A. All linear dimensions are in millimeters.
 - B. This drawing is subject to change without notice.
 - C. Package outline exclusive of metal burr & dambar protrusion/intrusion.
 - D. Package outline inclusive of solder plating.
 - E. A visual index feature must be located within the Pin 1 index area.
 - F. Falls within JEDEC MO-178 Variation BA.
 - G. Body dimensions do not include flash or protrusion. Mold flash and protrusion shall not exceed 0.25 per side.

DCN (R-PDSO-G8)

PLASTIC SMALL-OUTLINE PACKAGE (DIE DOWN)

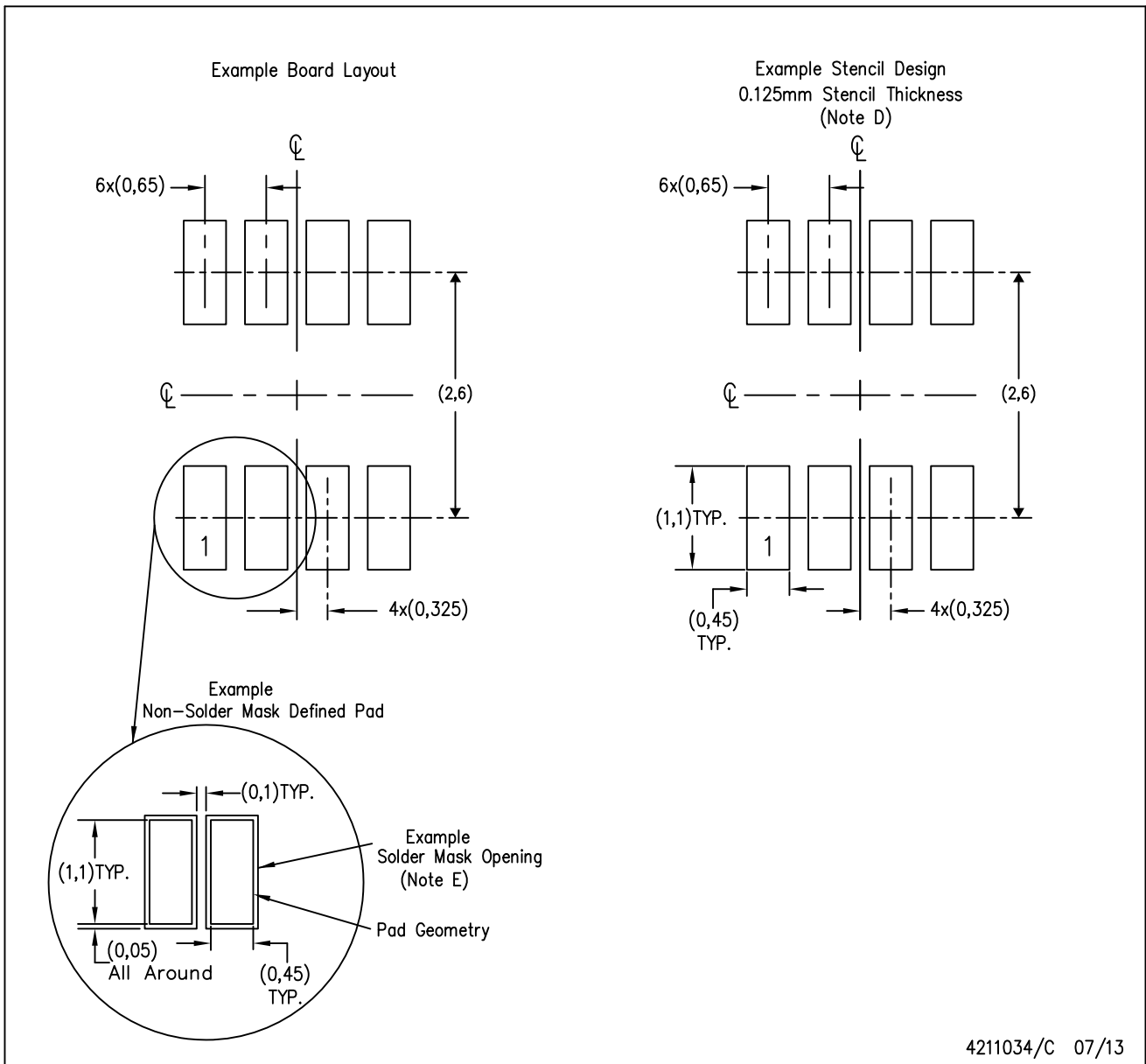

- NOTES:
- A. All linear dimensions are in millimeters.
 - B. This drawing is subject to change without notice.
 - C. Publication IPC-7351 is recommended for alternate designs.
 - D. Laser cutting apertures with trapezoidal walls and also rounding corners will offer better paste release. Customers should contact their board assembly site for stencil design recommendations. Refer to IPC-7525.
 - E. Customers should contact their board fabrication site for solder mask tolerances between and around signal pads.

D (R-PDSO-G14)

PLASTIC SMALL OUTLINE

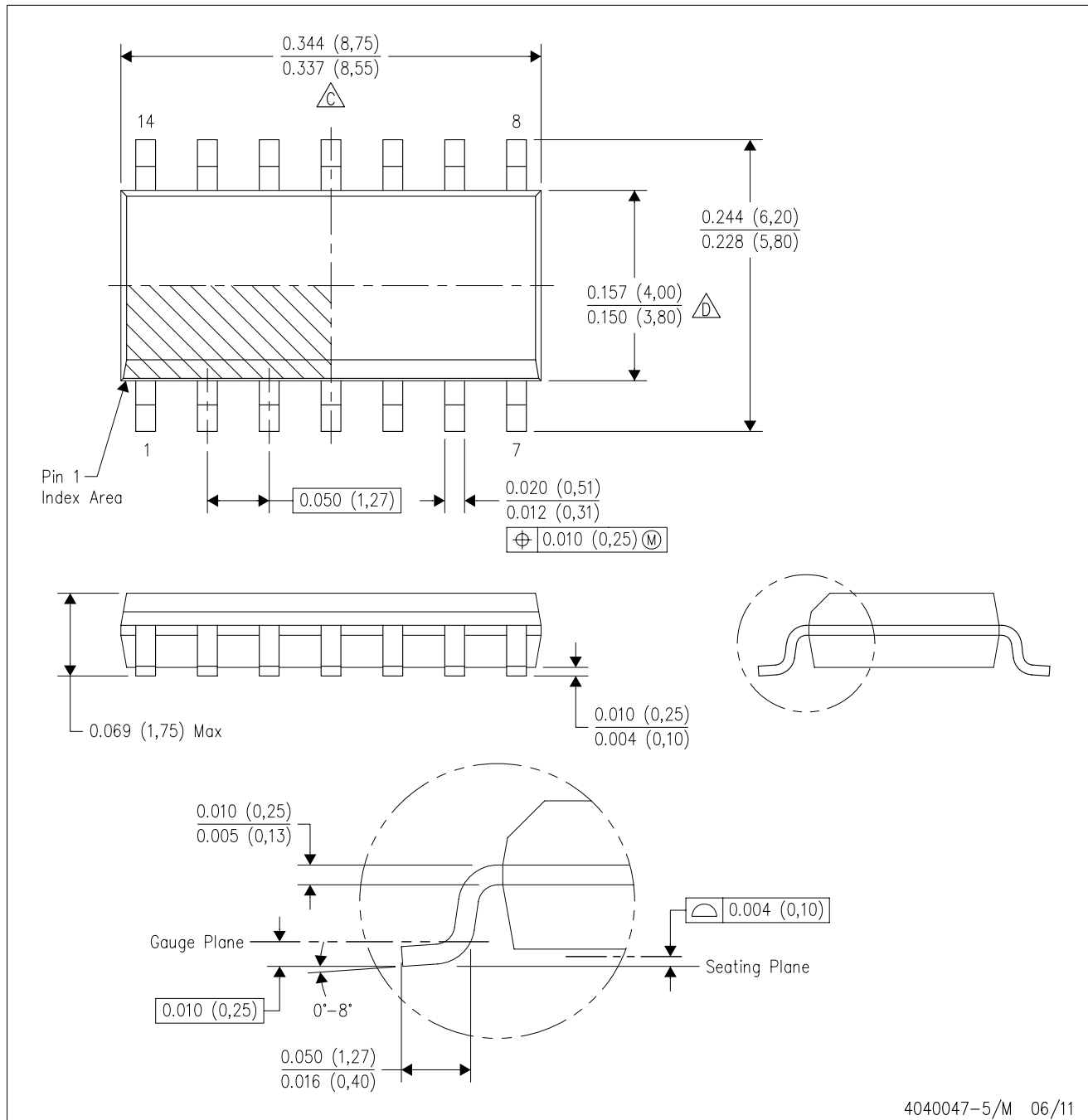

- NOTES:
- A. All linear dimensions are in inches (millimeters).
 - B. This drawing is subject to change without notice.
 -  Body length does not include mold flash, protrusions, or gate burrs. Mold flash, protrusions, or gate burrs shall not exceed 0.006 (0,15) each side.
 -  Body width does not include interlead flash. Interlead flash shall not exceed 0.017 (0,43) each side.
 - E. Reference JEDEC MS-012 variation AB.

D (R-PDSO-G14)

PLASTIC SMALL OUTLINE



- NOTES:
- All linear dimensions are in millimeters.
 - This drawing is subject to change without notice.
 - Publication IPC-7351 is recommended for alternate designs.
 - Laser cutting apertures with trapezoidal walls and also rounding corners will offer better paste release. Customers should contact their board assembly site for stencil design recommendations. Refer to IPC-7525 for other stencil recommendations.
 - Customers should contact their board fabrication site for solder mask tolerances between and around signal pads.

PW (R-PDSO-G14)

PLASTIC SMALL OUTLINE

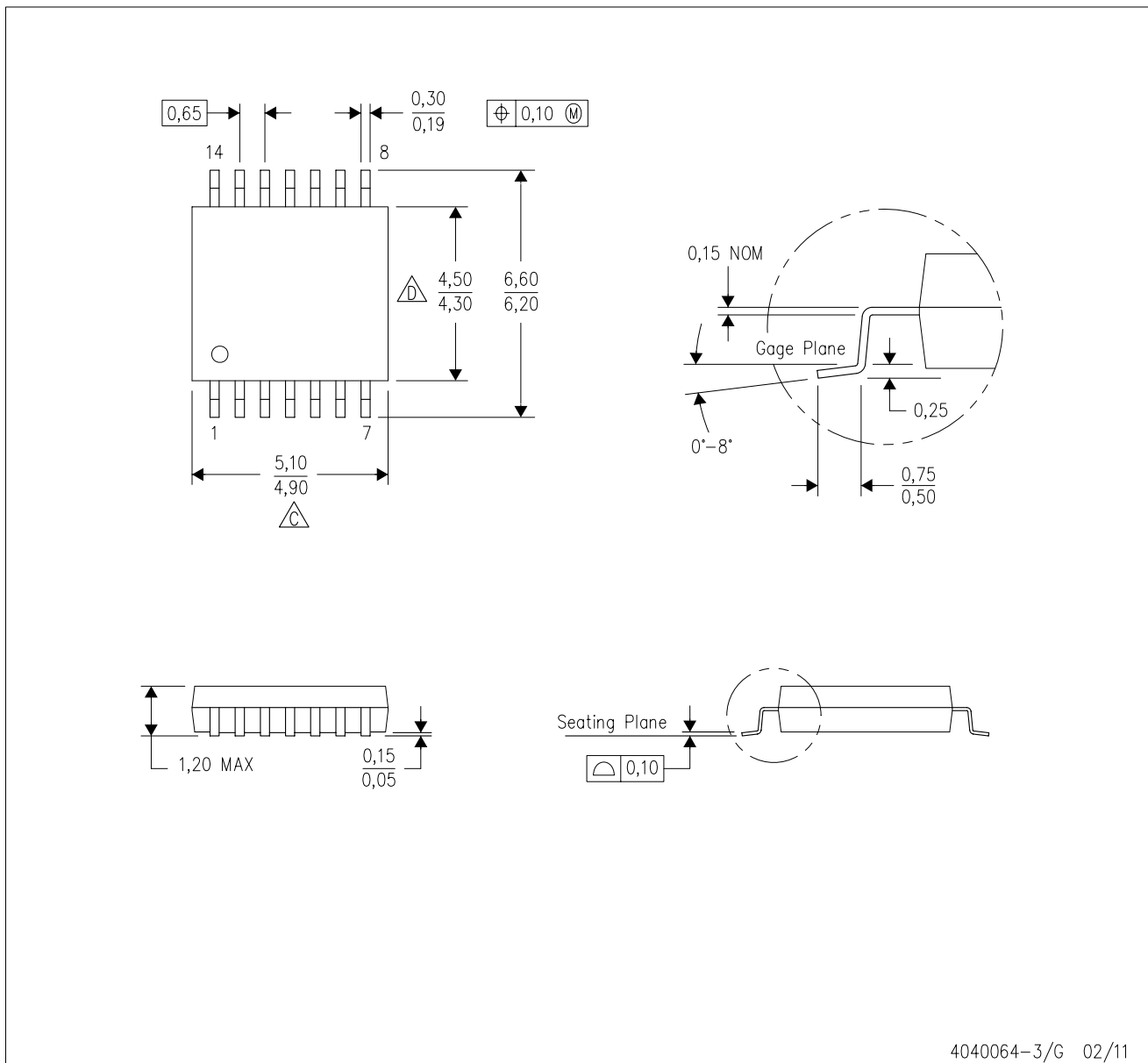

4040064-3/G 02/11

- NOTES:
- A. All linear dimensions are in millimeters. Dimensioning and tolerancing per ASME Y14.5M-1994.
 - B. This drawing is subject to change without notice.
 - C. Body length does not include mold flash, protrusions, or gate burrs. Mold flash, protrusions, or gate burrs shall not exceed 0,15 each side.
 - D. Body width does not include interlead flash. Interlead flash shall not exceed 0,25 each side.
 - E. Falls within JEDEC MO-153

PW (R-PDSO-G14)

PLASTIC SMALL OUTLINE



4211284-2/G 08/15

- NOTES:
- All linear dimensions are in millimeters.
 - This drawing is subject to change without notice.
 - Publication IPC-7351 is recommended for alternate designs.
 - Laser cutting apertures with trapezoidal walls and also rounding corners will offer better paste release. Customers should contact their board assembly site for stencil design recommendations. Refer to IPC-7525 for other stencil recommendations.
 - Customers should contact their board fabrication site for solder mask tolerances between and around signal pads.



D0008A

PACKAGE OUTLINE

SOIC - 1.75 mm max height

SMALL OUTLINE INTEGRATED CIRCUIT



4214825/C 02/2019

NOTES:

1. Linear dimensions are in inches [millimeters]. Dimensions in parenthesis are for reference only. Controlling dimensions are in inches. Dimensioning and tolerancing per ASME Y14.5M.
2. This drawing is subject to change without notice.
3. This dimension does not include mold flash, protrusions, or gate burrs. Mold flash, protrusions, or gate burrs shall not exceed $.006$ [0.15] per side.
4. This dimension does not include interlead flash.
5. Reference JEDEC registration MS-012, variation AA.

EXAMPLE BOARD LAYOUT

D0008A

SOIC - 1.75 mm max height

SMALL OUTLINE INTEGRATED CIRCUIT



LAND PATTERN EXAMPLE
EXPOSED METAL SHOWN
SCALE:8X



SOLDER MASK DETAILS

4214825/C 02/2019

NOTES: (continued)

6. Publication IPC-7351 may have alternate designs.

7. Solder mask tolerances between and around signal pads can vary based on board fabrication site.

EXAMPLE STENCIL DESIGN

D0008A

SOIC - 1.75 mm max height

SMALL OUTLINE INTEGRATED CIRCUIT



SOLDER PASTE EXAMPLE
BASED ON .005 INCH [0.125 MM] THICK STENCIL
SCALE:8X

4214825/C 02/2019

NOTES: (continued)

8. Laser cutting apertures with trapezoidal walls and rounded corners may offer better paste release. IPC-7525 may have alternate design recommendations.
9. Board assembly site may have different recommendations for stencil design.

IMPORTANT NOTICE AND DISCLAIMER

TI PROVIDES TECHNICAL AND RELIABILITY DATA (INCLUDING DATASHEETS), DESIGN RESOURCES (INCLUDING REFERENCE DESIGNS), APPLICATION OR OTHER DESIGN ADVICE, WEB TOOLS, SAFETY INFORMATION, AND OTHER RESOURCES "AS IS" AND WITH ALL FAULTS, AND DISCLAIMS ALL WARRANTIES, EXPRESS AND IMPLIED, INCLUDING WITHOUT LIMITATION ANY IMPLIED WARRANTIES OF MERCHANTABILITY, FITNESS FOR A PARTICULAR PURPOSE OR NON-INFRINGEMENT OF THIRD PARTY INTELLECTUAL PROPERTY RIGHTS.

These resources are intended for skilled developers designing with TI products. You are solely responsible for (1) selecting the appropriate TI products for your application, (2) designing, validating and testing your application, and (3) ensuring your application meets applicable standards, and any other safety, security, or other requirements. These resources are subject to change without notice. TI grants you permission to use these resources only for development of an application that uses the TI products described in the resource. Other reproduction and display of these resources is prohibited. No license is granted to any other TI intellectual property right or to any third party intellectual property right. TI disclaims responsibility for, and you will fully indemnify TI and its representatives against, any claims, damages, costs, losses, and liabilities arising out of your use of these resources.

TI's products are provided subject to TI's Terms of Sale (www.ti.com/legal/termsofsale.html) or other applicable terms available either on ti.com or provided in conjunction with such TI products. TI's provision of these resources does not expand or otherwise alter TI's applicable warranties or warranty disclaimers for TI products.

Mailing Address: Texas Instruments, Post Office Box 655303, Dallas, Texas 75265
Copyright © 2019, Texas Instruments Incorporated

Looking for pricing, stock, or lifecycle information?

Click below to explore more details on WIN SOURCE:

 [View TLV3491AIDBVT on WIN SOURCE](#)

 [Texas Instruments](#) Information

Optimize Your Supply Chain with WIN SOURCE Solutions

-  Global Sourcing Solution
-  Obsolete Management
-  Cost Control Management
-  Shortage Management
-  Alternative Solution
-  Excess Inventory Management