



**THE DATASHEET OF
TLV320ADC3101IRGET**



TLV320ADC3101 Low-Power Stereo ADC With Embedded miniDSP for Wireless Handsets and Portable Audio

1 Features

- Stereo Audio ADC
 - 92-dBA Signal-to-Noise Ratio
 - Supports ADC Sample Rates From 8 kHz to 96 kHz
- Instruction-Programmable Embedded miniDSP
- Flexible Digital Filtering With RAM Programmable Coefficient, Instructions, and Built-In Processing Blocks
 - Low-Latency IIR Filters for Voice
 - Linear Phase FIR Filters for Audio
 - Additional Programmable IIR Filters for EQ, Noise Cancellation or Reduction
 - Up to 128 Programmable ADC Digital Filter Coefficients
- Six Audio Inputs With Configurable Automatic Gain Control (AGC)
 - Programmable in Single-Ended or Fully Differential Configurations
 - Can Be 3-States for Easy Interoperability With Other Audio ICs
- Low Power Consumption and Extensive Modular Power Control:
 - 6-mW Mono Record, 8-kHz
 - 11-mW Stereo Record, 8-kHz
 - 10-mW Mono Record, 48-kHz
 - 17-mW Stereo Record, 48-kHz
- Dual Programmable Microphone Bias
- Programmable PLL for Clock Generation
- I²C Control Bus
- Audio Serial Data Bus Supports I²S, Left/Right-Justified, DSP, PCM, and TDM Modes
- Digital Microphone Input Support
- Two GPIOs
- Power Supplies:
 - Analog: 2.6 V to 3.6 V
 - Digital: Core: 1.65 V to 1.95 V, I/O: 1.1 V–3.6 V
- 4-mm × 4-mm 24-Pin RGE (VQFN)

2 Applications

- Wireless Handsets
- Portable Low-Power Audio Systems
- Noise-Cancellation Systems
- Front-End Voice or Audio Processor for Digital Audio

3 Description

The TLV320ADC3101 device is a low-power, stereo audio analog-to-digital converter (ADC) supporting sampling rates from 8 kHz to 96 kHz with an integrated programmable-gain amplifier providing up to 40-dB analog gain or AGC. A programmable miniDSP is provided for custom audio processing. Front-end input coarse attenuation of 0 dB, –6 dB, or off, is also provided. The inputs are programmable in a combination of single-ended or fully differential configurations. Extensive register-based power control is available via an I²C interface, enabling mono or stereo recording. Low power consumption makes the TLV320ADC3101 ideal for battery-powered portable equipment.

Device Information⁽¹⁾

PART NUMBER	PACKAGE	BODY SIZE (NOM)
TLV320ADC3101	VQFN (24)	4.00 mm × 4.00 mm

(1) For all available packages, see the orderable addendum at the end of the data sheet.

Functional Block Diagram

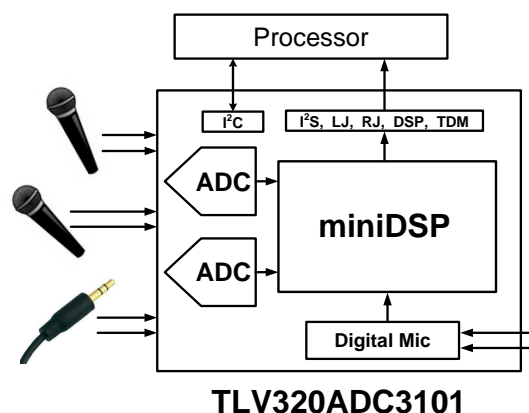

Table of Contents

1 Features	1	10 Detailed Description	12
2 Applications	1	10.1 Overview	12
3 Description	1	10.2 Functional Block Diagram	13
4 Revision History	2	10.3 Feature Description	13
5 Description (continued)	3	10.4 Device Functional Modes	41
6 Device Comparison Table	3	10.5 Programming	42
7 Pin Configuration and Functions	4	10.6 Register Maps	43
8 Specifications	5	11 Application and Implementation	78
8.1 Absolute Maximum Ratings	5	11.1 Application Information	78
8.2 ESD Ratings	5	11.2 Typical Application	78
8.3 Recommended Operating Conditions	5	12 Power Supply Recommendations	82
8.4 Thermal Information	6	13 Layout	83
8.5 Electrical Characteristics	6	13.1 Layout Guidelines	83
8.6 Dissipation Ratings	7	13.2 Layout Example	83
8.7 I ² S/LJF/RJF Timing in Master Mode	8	14 Device and Documentation Support	84
8.8 DSP Timing in Master Mode	8	14.1 Community Resources	84
8.9 I ² S/LJF/RJF Timing in Slave Mode	8	14.2 Trademarks	84
8.10 DSP Timing in Slave Mode	8	14.3 Electrostatic Discharge Caution	84
8.11 Typical Characteristics	11	14.4 Glossary	84
9 Parameter Measurement Information	11	15 Mechanical, Packaging, and Orderable Information	84

4 Revision History

NOTE: Page numbers for previous revisions may differ from page numbers in the current version.

Changes from Revision A (September 2009) to Revision B	Page
• Added <i>Pin Configuration and Functions</i> section, <i>ESD Ratings</i> table, <i>Feature Description</i> section, <i>Device Functional Modes</i> , <i>Application and Implementation</i> section, <i>Power Supply Recommendations</i> section, <i>Layout</i> section, <i>Device and Documentation Support</i> section, and <i>Mechanical, Packaging, and Orderable Information</i> section	1

Changes from Original (November 2008) to Revision A	Page
• Revised column heading for <i>Pin Functions</i> table	4
• Added voltage value for AVDD in <i>Electrical Characteristics</i> condition statement	6
• Added "Input common-mode voltage" to ADC <i>Electrical Characteristics</i> Table	6
• Added voltage value for AVDD in <i>Electrical Characteristics</i> condition statement	7
• Added a row to the Microphone Bias section of the <i>Electrical Characteristics</i> table	7
• Changed Figure 4 - DSP Timing in Slave Mode. Added the WCLK text note.	10
• Changed Figure 9 - Single-Ended Dynamic Range Plot to Input-Referred Noise vs PGA Gain	11
• Changed Revised block diagram	13
• Added miniDSP Section and miniDSP Information Throughout Datasheet	14
• Added Figure 40 - 2s Complement Coefficient Format	35
• Changed Data Format for All Control Register Definitions From Decimal To Hex (Binary)	43
• Removed note following the page 0 / register 94 description table	62
• Changed bit values from 1 and 2 to 0 and 1, respectively.	62
• Listed values 81 through 127 as reserved	62
• Replaced the listing of page 4 registers	69
• Added a listing for page 5 registers	73

5 Description (continued)

The AGC programs to a wide range of attack (7 ms to 1.4 s) and decay (50 ms to 22.4 s) times. A programmable noise-gate function is included to avoid noise pumping. Low-latency IIR filters optimized for voice and telephony are available, as well as linear-phase FIR filters optimized for audio. Programmable IIR filters are also available and may be used for sound equalization, or to remove noise components. The audio serial bus can be programmed to support I²S, left-justified, right-justified, DSP, PCM, and TDM modes. The audio bus may be operated in either master or slave mode.

A programmable integrated PLL is included for flexible clock generation and provides support for all standard audio rates from a wide range of available MCLKs, varying from 512 kHz to 50 MHz, including the most popular cases of 12-MHz, 13-MHz, 16-MHz, 19.2-MHz, and 19.68-MHz system clocks.

6 Device Comparison Table

FEATURES	TLV320ADC3101	TLV320ADC3001
Number of ADCs	2	2
Number of Inputs / Outputs	6 / Digital I/F	3 / Digital I/F
Resolution (Bits)	24	24
Control Interface	I ² C	I ² C
Digital Audio Interface	LJ, RJ, I2S, DSP, TDM	LJ, RJ, I2S, DSP, TDM
Digital Microphone Support	Yes	No

7 Pin Configuration and Functions

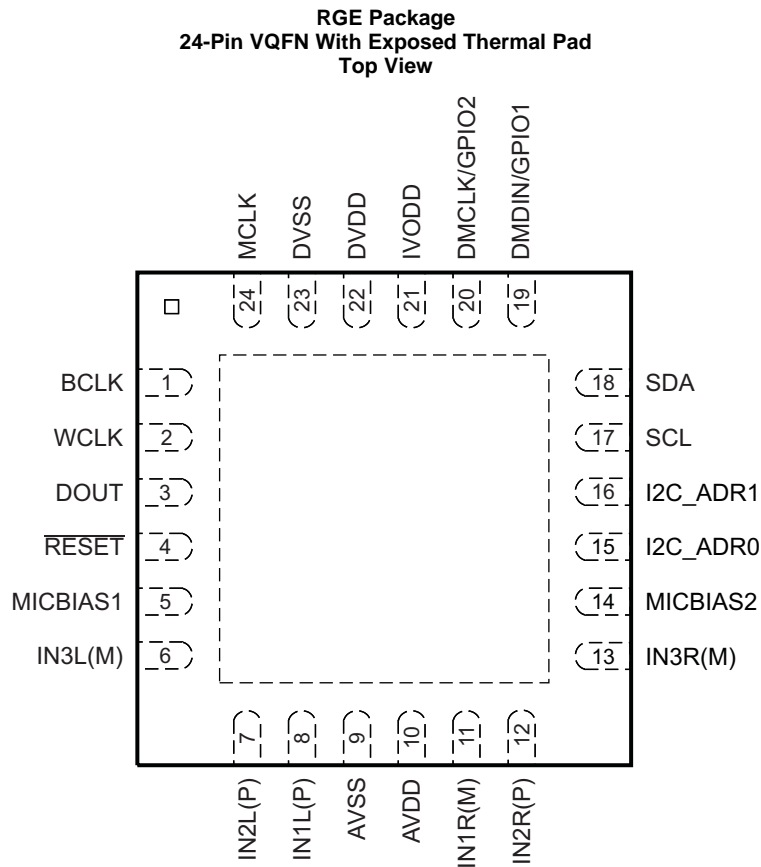

Connect the VQFN thermal pad to AVSS.

Pin Functions

PIN		TYPE	DESCRIPTION
NAME	NO.		
AVDD	10	P	Analog voltage supply, 2.6 V–3.6 V
AVSS	9	P	Analog ground supply, 0 V
BCLK	1	I/O	Audio serial data bus bit clock (input/output)
DMCLK/GPIO2	20	I/O	Digital microphone clock / general-purpose input/output 2 (input/output) / PLL clock input / audio serial data-bus bit-clock input/output / multifunction pin based on register programming
DMDIN/GPIO1	19	I/O	Digital microphone data input / general-purpose input/output 1 (input/output) / PLL clock mux output / AGC noise flag / multifunction pin based on register programming
DOUT	3	O	Audio serial data bus data output (output)
DVDD	22	P	Digital core voltage supply, 1.65 V–1.95 V
DVSS	23	P	Digital ground supply, 0 V
I2C_ADR0	15	I	LSB of I ² C bus address
I2C_ADR1	16	I	LSB + 1 of I ² C bus address
IN1L(P)	8	I	Mic or line analog input (left-channel single-ended or differential plus, or right channel)
IN1R(M)	11	I	Mic or line analog input (left-channel single-ended or differential minus, or left channel)
IN2L(P)	7	I	Mic or line analog input (left-channel single-ended or differential plus)
IN2R(P)	12	I	Mic or line analog input (right-channel single-ended or differential plus)
IN3L(M)	6	I	Mic or line analog input (left-channel single-ended or differential minus)
IN3R(M)	13	I	Mic or line analog input (right-channel single-ended or differential minus)

Pin Functions (continued)

PIN		TYPE	DESCRIPTION
NAME	NO.		
IOVDD	21	P	I/O voltage supply, 1.1 V–3.6 V
MCLK	24	I	Master clock input
MICBIAS1	5	O	MICBIAS1 bias voltage output
MICBIAS2	14	O	MICBIAS2 bias voltage output
$\overline{\text{RESET}}$	4	I	Reset
SCL	17	I/O	I ² C serial clock
SDA	18	I/O	I ² C serial data input/output
WCLK	2	I/O	Audio serial data bus word clock (input/output)

8 Specifications

8.1 Absolute Maximum Ratings

over operating free-air temperature range (unless otherwise noted)⁽¹⁾ ⁽²⁾

	MIN	MAX	UNIT
AVDD to AVSS	–0.3	3.9	V
IOVDD to DVSS	–0.3	3.9	V
DVDD to DVSS	–0.3	2.5	V
Digital input voltage to DVSS	–0.3	IOVDD + 0.3	V
Analog input voltage to AVSS	–0.3	AVDD + 0.3	V
Operating temperature	–40	85	°C
T _J Max Junction temperature		105	°C
Power dissipation	$(T_J \text{ Max} - T_A) / \theta_{JA}$		W
T _{stg} Storage temperature	–65	125	°C

- (1) Stresses beyond those listed under *Absolute Maximum Ratings* may cause permanent damage to the device. These are stress ratings only, and functional operation of the device at these or any other conditions beyond those indicated under *Recommended Operating Conditions* is not implied. Exposure to absolute-maximum-rated conditions for extended periods may affect device reliability.
- (2) ESD complacence tested to EIA / JESD22-A114-B and passed.

8.2 ESD Ratings

	VALUE	UNIT
V _(ESD) Electrostatic discharge	Human body model (HBM), per ANSI/ESDA/JEDEC JS-001 ⁽¹⁾	±1000
	Charged-device model (CDM), per JEDEC specification JESD22-C101 ⁽²⁾	±250
		V

- (1) JEDEC document JEP155 states that 500-V HBM allows safe manufacturing with a standard ESD control process.
- (2) JEDEC document JEP157 states that 250-V CDM allows safe manufacturing with a standard ESD control process.

8.3 Recommended Operating Conditions

over operating free-air temperature range (unless otherwise noted)

	MIN	NOM	MAX	UNIT
AVDD ⁽¹⁾ Analog supply voltage	2.6	3.3	3.6	V
DVDD ⁽¹⁾ Digital core supply voltage	1.65	1.8	1.95	V
IOVDD ⁽¹⁾ Digital I/O supply voltage	1.1	1.8	3.6	V
V _I Analog full-scale 0-dB input voltage (AVDD = 3.3 V)	0.707			V _{rms}
Digital output load capacitance	10			pF
T _A Operating free-air temperature	–40		85	°C

- (1) Analog voltage values are with respect to AVSS; digital voltage values are with respect to DVSS.

8.4 Thermal Information

THERMAL METRIC ⁽¹⁾		TLV320ADC3101	UNIT
		RGE (VQFN)	
		24 PINS	
R _{θJA}	Junction-to-ambient thermal resistance	33.9	°C/W
R _{θJC(top)}	Junction-to-case (top) thermal resistance	34.1	°C/W
R _{θJB}	Junction-to-board thermal resistance	11.5	°C/W
ψ _{JT}	Junction-to-top characterization parameter	0.4	°C/W
ψ _{JB}	Junction-to-board characterization parameter	11.5	°C/W
R _{θJC(bot)}	Junction-to-case (bottom) thermal resistance	3.2	°C/W

(1) For more information about traditional and new thermal metrics, see the *Semiconductor and IC Package Thermal Metrics* application report, [SPRA953](#).

8.5 Electrical Characteristics

At 25°C, AVDD = 3.3 V, IOVDD = 1.8 V, DVDD = 1.8 V, f_S = 48-kHz, 16-bit audio data (unless otherwise noted)

PARAMETER		TEST CONDITIONS	MIN	TYP	MAX	UNIT
AUDIO ADC						
	Input signal level (0-dB)	Single-ended input		0.707		V _{rms}
	Input common-mode voltage	Single-ended input		1.35		V _{rms}
SNR	Signal-to-noise ratio, A-weighted ^{(1) (2)}	f _S = 48 kHz, 0-dB PGA gain, IN1 inputs selected and AC-shortened to ground	80	92		dB
	Dynamic range, A-weighted ^{(1) (2)}	f _S = 48 kHz, 1-kHz –60-dB full-scale input applied at IN1 inputs, 0-dB PGA gain		92		dB
THD	Total harmonic distortion	f _S = 48 kHz, 1-kHz –2-dB full-scale input applied at IN1 inputs, 0-dB PGA gain		–90	–75	dB
				0.003%	0.017%	
PSRR	Power supply rejection ratio	234 Hz, 100 mV _{PP} on AVDD, single-ended input		46		dB
		234 Hz, 100 mV _{PP} on AVDD, differential input		68		dB
	ADC channel separation	1 kHz, –2 dB IN1L to IN1R		–73		dB
	ADC gain error	1 kHz input, 0-dB PGA gain		0.7		dB
	ADC programmable-gain amplifier maximum gain	1-kHz input tone, R _{SOURCE} < 50 Ω		40		dB
	ADC programmable-gain amplifier step size			0.502		dB
	Input resistance	IN1 inputs, routed to single ADC Input mix attenuation = 0 dB		35		kΩ
		IN2 inputs, input mix attenuation = 0 dB		35		
		IN1 inputs, input mix attenuation = –6 dB		62.5		
		IN2 inputs, input mix attenuation = –6 dB		62.5		
	Input capacitance			10		pF
	Input level control minimum attenuation setting			0		dB
	Input level control maximum attenuation setting			6		dB
	Input level control attenuation step size			6		dB

- (1) Ratio of output level with 1-kHz full-scale sine-wave input, to the output level with the inputs short-circuited, measured A-weighted over a 20-Hz to 20-kHz bandwidth using an audio analyzer.
- (2) All performance measurements done with 20-kHz low-pass filter and, where noted, A-weighted filter. Failure to use such a filter may result in higher THD and lower SNR and dynamic range readings than shown in the *Electrical Characteristics*. The low-pass filter removes out-of-band noise, which, although not audible, may affect dynamic specification values.

Electrical Characteristics (continued)

At 25°C, AVDD = 3.3 V, IOVDD = 1.8 V, DVDD = 1.8 V, $f_S = 48$ -kHz, 16-bit audio data (unless otherwise noted)

PARAMETER	TEST CONDITIONS	MIN	TYP	MAX	UNIT
ADC DIGITAL DECIMATION FILTER $f_S = 48$ kHz					
Filter gain from 0 to $0.39 f_S$	Filter A, AOSR = 128 or 64		± 0.1		dB
Filter gain from $0.55 f_S$ to $64 f_S$	Filter A, AOSR = 128 or 64		-73		dB
Filter group delay	Filter A, AOSR = 128 or 64		$17/f_S$		s
Filter gain from 0 to $0.39 f_S$	Filter B, AOSR = 64		± 0.1		dB
Filter gain from $0.60 f_S$ to $32 f_S$	Filter B, AOSR = 64		-46		dB
Filter group delay	Filter B, AOSR = 64		$11/f_S$		s
Filter gain from 0 to $0.39 f_S$	Filter C, AOSR = 32		± 0.033		dB
Filter gain from $0.28 f_S$ to $16 f_S$	Filter C, AOSR = 32		-60		dB
Filter group delay	Filter C, AOSR = 32		$11/f_S$		s
MICROPHONE BIAS					
Bias voltage	Programmable settings, load = 750 Ω		2		V
		2.25	2.5	2.75	
		AVDD – 0.2			
Current sourcing	2.5-V setting			4	mA
Integrated noise	BW = 20 Hz to 20 kHz, A-weighted, 1- μ F capacitor between MICBIAS and AGND		3.3		μ V rms
DIGITAL I/O					
V_{IL}	Input low level	$I_{IL} = 5 \mu A$	-0.3	$0.3 \times IOVDD$	V
V_{IH}	Input high level ⁽³⁾	$I_{IH} = 5 \mu A$	$0.7 \times IOVDD$		V
V_{OL}	Output low level	$I_{IH} = 2$ TTL loads		$0.1 \times IOVDD$	V
V_{OH}	Output high level	$I_{OH} = 2$ TTL loads	$0.8 \times IOVDD$		V
SUPPLY CURRENT $f_S = 48$ kHz, AVDD = 3.3 V, DVDD = IOVDD = 1.8 V					
Mono record	AVDD	PLL and AGC off	2		mA
	DVDD		1.9		
Stereo record	AVDD	PLL and AGC off	4		mA
	DVDD		2.1		
PLL	AVDD	Additional power consumed when PLL is powered	1.1		mA
	DVDD		0.8		
Power down	AVDD	All supply voltages applied, all blocks programmed in lowest power state	0.04		μ A
	DVDD		0.7		

(3) When IOVDD < 1.6 V, minimum V_{IH} is 1.1 V.

8.6 Dissipation Ratings⁽¹⁾

PACKAGE TYPE	$T_A = 25^\circ C$ POWER RATING	DERATING FACTOR	$T_A = 75^\circ C$ POWER RATING	$T_A = 85^\circ C$ POWER RATING
VQFN	1.7 W	22 mW/°C	665 mW	444 mW

(1) This data was taken using 2-oz. (0.071-mm thick) trace and copper pad that is soldered directly to a JEDEC standard 4-layer 3-in. \times 3-in. (7.62-cm \times 7.62-cm) PCB.

8.7 I²S/LJF/RJF Timing in Master Mode

Specified at 25°C, DVDD = 1.8 V, all timing specifications are measured at characterization. See [Figure 1](#) for timing diagram.

		IOVDD = 1.8 V		IOVDD = 3.3 V		UNIT
		MIN	MAX	MIN	MAX	
t _d (WS)	BCLK/WCLK delay time		20		15	ns
t _d (DO-WS)	BCLK/WCLK to DOUT delay time		25		20	ns
t _d (DO-BCLK)	BCLK to DOUT delay time		20		15	ns
t _r	Rise time		20		15	ns
t _f	Fall time		20		15	ns

8.8 DSP Timing in Master Mode

Specified at 25°C, DVDD = 1.8 V, all timing specifications are measured at characterization. See [Figure 2](#) for timing diagram.

		IOVDD = 1.8 V		IOVDD = 3.3 V		UNIT
		MIN	MAX	MIN	MAX	
t _d (WS)	BCLK/WCLK delay time		25		15	ns
t _d (DO-BCLK)	BCLK to DOUT delay time		25		15	ns
t _r	Rise time		20		15	ns
t _f	Fall time		20		15	ns

8.9 I²S/LJF/RJF Timing in Slave Mode

Specified at 25°C, DVDD = 1.8 V, all timing specifications are measured at characterization. See [Figure 3](#) for timing diagram.

		IOVDD = 1.8 V		IOVDD = 3.3 V		UNIT
		MIN	MAX	MIN	MAX	
t _H (BCLK)	BCLK high period	35		35		ns
t _L (BCLK)	BCLK low period	35		35		ns
t _s (WS)	BCLK/WCLK set-up time	10		6		ns
t _h (WS)	BCLK/WCLK hold time	10		6		ns
t _d (DO-WS)	BCLK/WCLK to DOUT delay time (for LJF Mode only)		30		30	ns
t _d (DO-BCLK)	BCLK to DOUT delay time		25		20	ns
t _r	Rise time		16		8	ns
t _f	Fall time		16		8	ns

8.10 DSP Timing in Slave Mode

Specified at 25°C, DVDD = 1.8 V, all timing specifications are measured at characterization. See [Figure 4](#) for timing diagram.

		IOVDD = 1.8 V		IOVDD = 3.3 V		UNIT
		MIN	MAX	MIN	MAX	
t _H (BCLK)	BCLK high period	35		35		ns
t _L (BCLK)	BCLK low period	35		35		ns
t _s (WS)	BCLK/WCLK set-up time	10		8		ns
t _h (WS)	BCLK/WCLK hold time	10		8		ns
t _d (DO-BCLK)	BCLK to DOUT delay time		25		20	ns
t _r	Rise time		15		8	ns
t _f	Fall time		15		8	ns

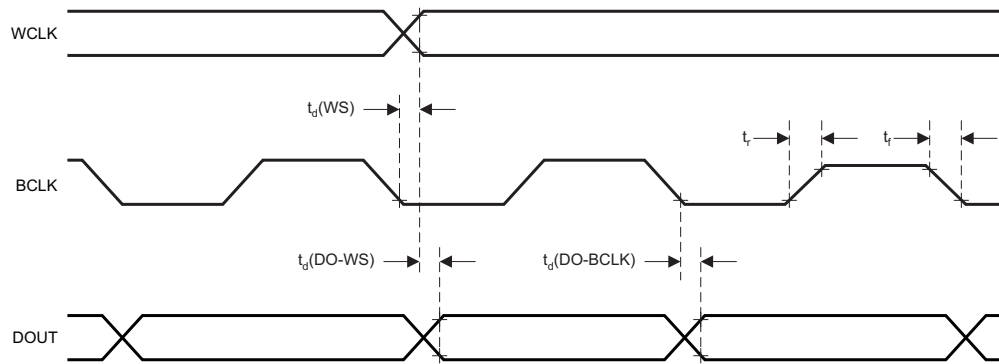

Figure 1. I²S/LJF/RJF Timing in Master Mode

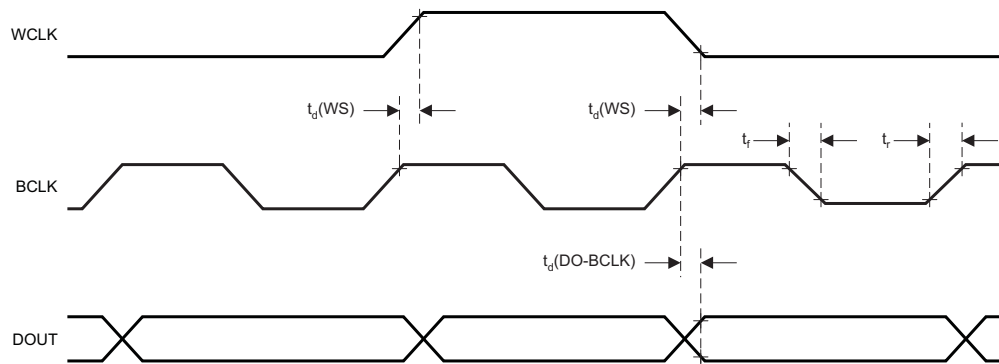

Figure 2. DSP Timing in Master Mode

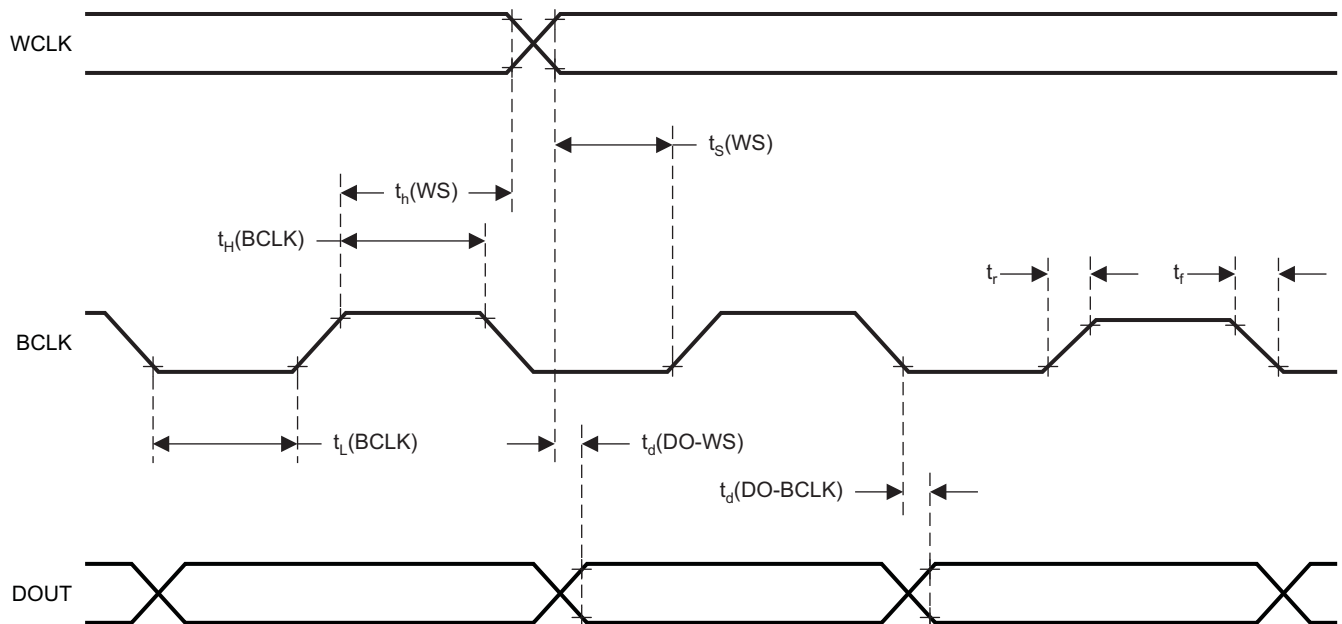
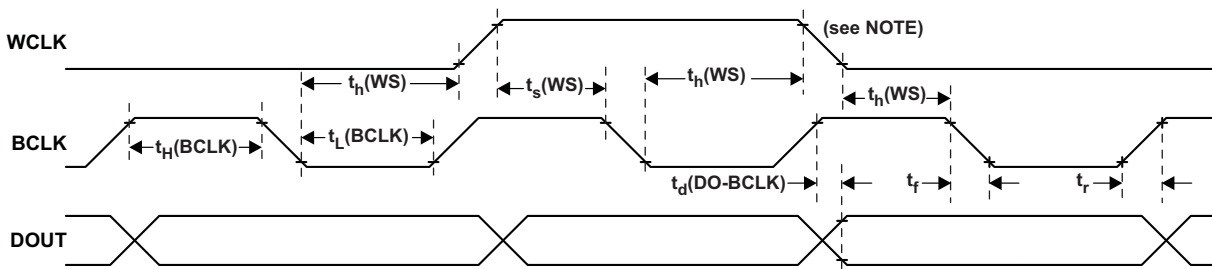

Figure 3. I²S/LJF/RJF Timing in Slave Mode



Note A. Falling edge inside a frame for WCLK is arbitrary inside frame.

Figure 4. DSP Timing in Slave Mode

8.11 Typical Characteristics

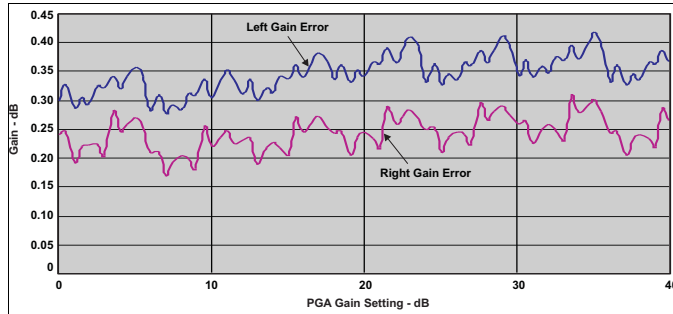

Figure 5. Single-Ended Gain Error

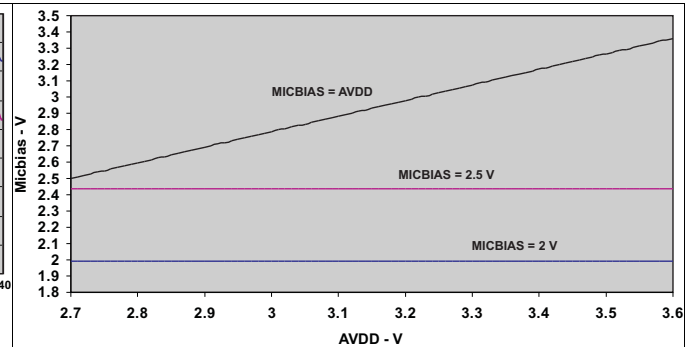

Figure 6. MICBIAS Output Voltage vs AVDD

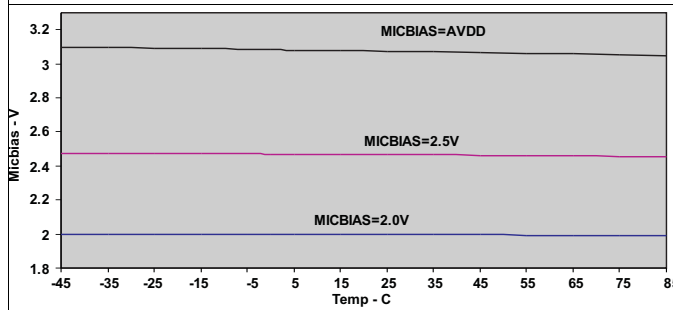

Figure 7. MICBIAS Output Voltage vs Ambient Temperature

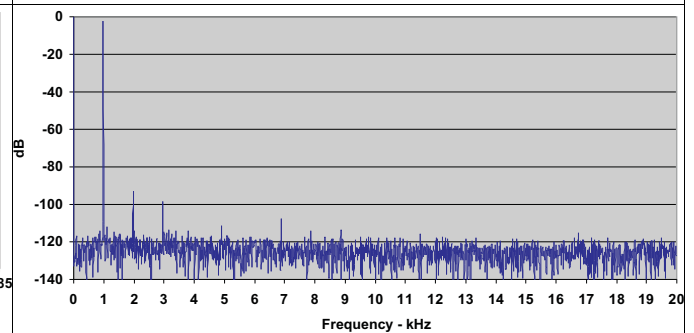

Figure 8. Line Input to ADC FFT Plot

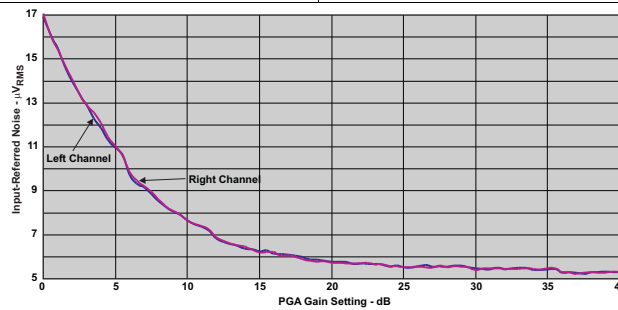

Figure 9. Input-Referred Noise vs PGA Gain

9 Parameter Measurement Information

All parameters are measured according to the conditions described in the [Specifications](#) section.

10 Detailed Description

10.1 Overview

The TLV320ADC3101 is a flexible, low-power, stereo audio ADC device with extensive feature integration, intended for applications in smartphones, PDAs, and portable computing, communication, and entertainment applications. The device integrates a host of features to reduce cost, board space, and power consumption in space-constrained, battery-powered, portable applications.

The TLV320ADC3101 consists of the following blocks:

- Stereo audio multibit delta-sigma ADC (8 kHz–96 kHz)
- Programmable digital audio effects processing (3-D, bass, treble, mid-range, EQ, de-emphasis)
- Register-configurable combinations of up to six single-ended or three differential audio inputs
- Fully programmable PLL with extensive ADC clock-source and divider options for maximum end-system design flexibility

Communication to the TLV320ADC3101 for control is via a two-wire I²C interface. The I²C interface supports both standard and fast communication modes.

10.2 Functional Block Diagram

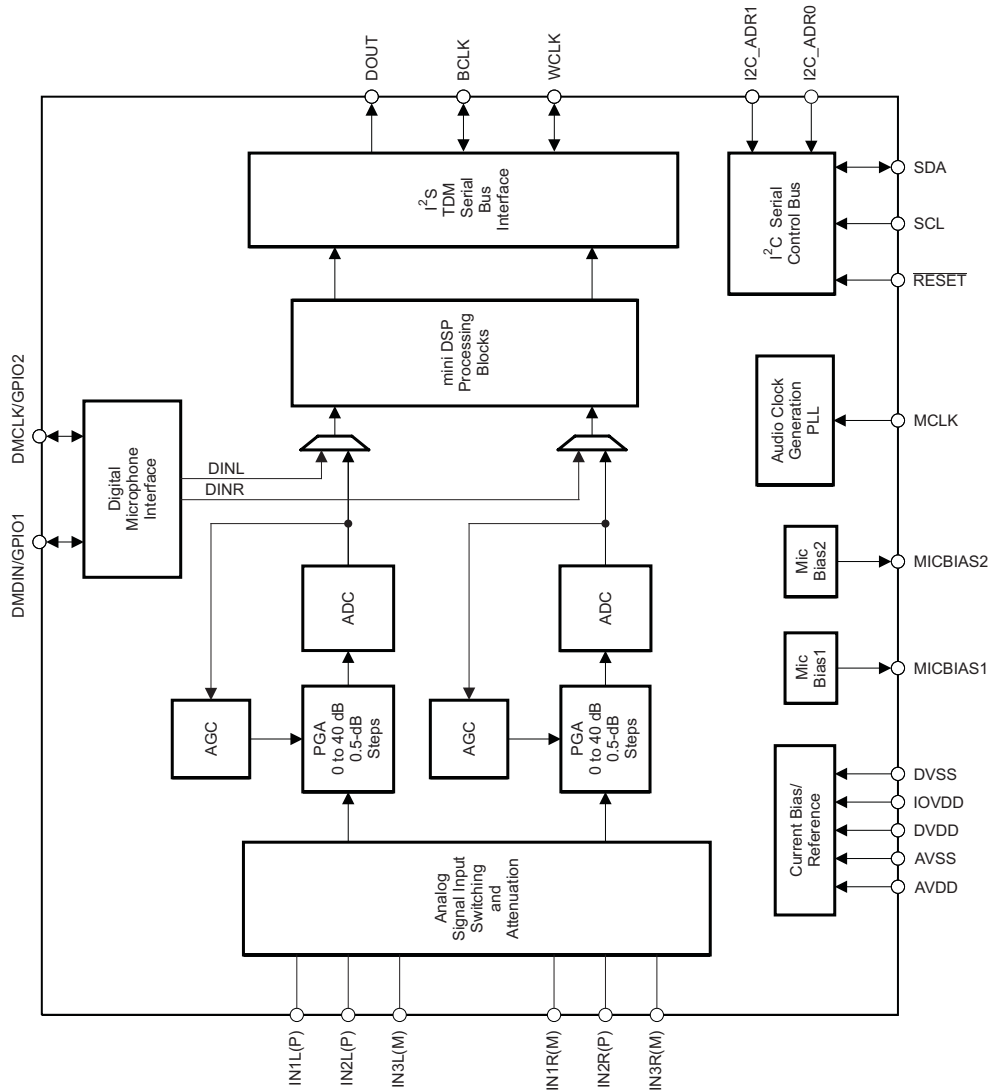

Figure 10. TLV320ADC3101 Block Diagram

10.3 Feature Description

10.3.1 Hardware Reset

The TLV320ADC3101 requires a hardware reset after power up for proper operation. After all power supplies are at their specified values, the RESET pin must be driven low for at least 10 ns. If this reset sequence is not performed, the TLV320ADC3101 may not respond properly to register reads/writes.

10.3.2 PLL Start-up

When the PLL is powered on, a start-up delay of approximately 10 ms occurs after the power-up command of the PLL and before the clocks are available to the TLV320ADC3101. This delay is to ensure stable operation of the PLL and clock-divider logic.

Feature Description (continued)

10.3.3 Software Power Down

By default, all circuit blocks are powered down following a reset condition. Hardware power up of each circuit block can be controlled by writing to the appropriate control register. This approach allows the lowest power-supply current for the functionality required. However, when a block is powered down, all of the register settings are maintained as long as power is still being applied to the device.

10.3.4 miniDSP

The TLV320ADC3101 features a miniDSP core which is tightly coupled to the ADC. The fully programmable algorithms for the miniDSP must be loaded into the device after power up. The miniDSP has direct access to the digital stereo audio stream, offering the possibility for advanced, very low-group-delay DSP algorithms. The ADC miniDSP has 512 programmable instructions, 256 data memory locations, and 128 programmable coefficients.

Software development for the TLV320ADC3101 is supported through TI's comprehensive PurePath™ Studio software development environment, a powerful, easy-to-use tool designed specifically to simplify software development on Texas Instruments miniDSP audio platforms. The graphical development environment consists of a library of common audio functions that can be dragged and dropped into an audio signal flow and graphically connected together. The DSP code can then be assembled from the graphical signal flow with the click of a mouse. See the TLV320ADC3101 product folder on www.ti.com to learn more about PurePath Studio software and the latest status on available, ready-to-use DSP algorithms.

10.3.5 Audio Data Converters

The TLV320ADC3101 supports the following standard audio sampling rates: 8 kHz, 11.025 kHz, 12 kHz, 16 kHz, 22.05 kHz, 24 kHz, 32 kHz, 44.1 kHz, 48 kHz, 88.2 kHz, and 96 kHz. The converters can also operate at different sampling rates in various combinations, which are described further as follows.

The TLV320ADC3101 supports a wide range of options for generating clocks for the ADC section as well as the digital interface section and the other control blocks, as shown in [Figure 28](#). The clocks for the ADC require a source reference clock. The clock can be provided on device pins MCLK and BCLK. The source reference clock for the ADC section can be chosen by programming the ADC_CLKIN value on page 0 / register 4, bits D1–D0. The ADC_CLKIN can then be routed through highly flexible clock dividers, shown in [Figure 28](#), to generate various clocks required for the ADC and programmable digital filter sections. In the event that the desired audio or programmable digital filter clocks cannot be generated from the external reference clocks on MCLK and BCLK, the TLV320ADC3101 also provides the option of using an on-chip PLL that supports a wide range of fractional multiplication values to generate the required system clocks. Starting from ADC_CLKIN, the TLV320ADC3101 provides for several programmable clock dividers to support a variety of sampling rates for the ADC and the clocks for the programmable digital filter section.

10.3.6 Digital Audio Data Serial Interface

Audio data is transferred between the host processor and the TLV320ADC3101 via the digital-audio serial-data interface, or audio bus. The audio bus on this device is flexible, including left- or right-justified data options, support for I²S or PCM protocols, programmable data-length options, a TDM mode for multichannel operation, flexible master/slave configurability for each bus clock line, and the ability to communicate with multiple devices within a system directly.

The audio serial interface on the TLV320ADC3101 has an extensive I/O control to allow for communicating with two independent processors for audio data. The processors can communicate with the device one at a time. This feature is enabled by register programming of the various pin selections.

The audio bus of the TLV320ADC3101 can be configured for left- or right-justified, I²S, DSP, or TDM modes of operation, where communication with standard telephony PCM interfaces is supported within the TDM mode. These modes are all MSB-first, with data width programmable as 16, 20, 24, or 32 bits by configuring page 0 / register 27, bits D5–D4. In addition, the word clock and bit clock can be independently configured in either master or slave mode for flexible connectivity to a wide variety of processors. The word clock is used to define the beginning of a frame, and may be programmed as either a pulse or a square-wave signal. The frequency of this clock corresponds to the maximum of the selected ADC sampling frequencies.

Feature Description (continued)

The bit clock is used to clock in and out the digital audio data across the serial bus. When in master mode, this signal can be programmed to generate variable clock pulses by controlling the bit-clock divider in page 0 / register 30 (see Figure 28). Accommodating various word lengths as well as supporting the case when multiple TLV320ADC3101s share the same audio bus may require that the number of bit-clock pulses in a frame be adjusted.

The TLV320ADC3101 also includes a feature to offset the position of the start of data a transfer with respect to the word clock. There are two configurations that afford the user to use either a single offset for both channels or to use separate offsets. Ch_Offset_1 reference represents the value in page 0 / register 28 and Ch_Offset_2 represents the value in page 0 / register 37. When page 0 / register 38, bit D0 is set to zero (time-slot-based channel assignment is disabled), the offset of both channels is controlled, in terms of number of bit clocks, by the programming in page 0 / register 28 (Ch_Offset_1). When page 0 / register 38, bit D0 = 1 (time-slot-based channel assignment enabled), the first channel is controlled, in terms of number of bit clocks, by the programming in page 0 / register 28 (Ch_Offset_1), and the second channel is controlled, in terms of number of bit clocks, by the programming in page 0 / register 37 (Ch_Offset_2), where register 37 programs the delay between the first word and the second word. Also, the relative order of the two channels can be swapped, depending on the programmable register bit (page 0 / register 38, bit D4) that enables swapping of the channels.

The TLV320ADC3101 also supports a feature of inverting the polarity of bit clock used for transferring the audio data as compared to the default clock polarity used. This feature can be used independently of the mode of audio interface chosen. This can be configured by writing to page 0 / register 29, bit D3.

The TLV320ADC3101 further includes programmability (page 0 / register 27, bit D0) to place DOUT in the high-impedance state at the end of data transfer (that is, at the end of the bit cycle corresponding to the LSB of a channel). By combining this capability with the ability to program at what bit clock in a frame the audio data begins, time-division multiplexing (TDM) can be accomplished, resulting in multiple ADCs able to use a single audio serial data bus. To further enhance the 3-state capability, the TLV320ADC3101 can be put in a high-impedance state a half bit cycle earlier by setting page 0 / register 38, bit D1 to 1. When the audio serial data bus is powered down while configured in master mode, the pins associated with the interface are put into a high-impedance output state.

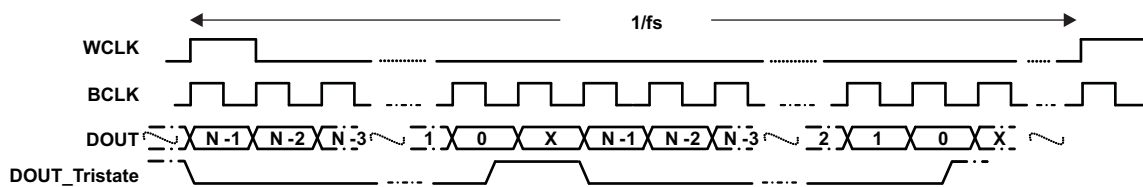

Figure 11. Both Channels Enabled, Early 3-Stating Enabled

Either or both of the two channels can be disabled in LJF, I²S, and DSP modes by using page 0 / register 38, bits D3–D2. Figure 11 shows the interface timing when both channels are enabled and early 3-stating is enabled. Figure 12 shows the effect of setting page 0 / register 38, bit D2, first channel disabled, and setting page 0 / register 27, bit D0 to 1, which enables placing DOUT in the high-impedance state. If placing DOUT in the high-impedance state is disabled, then the DOUT signal is driven to logic level 0.

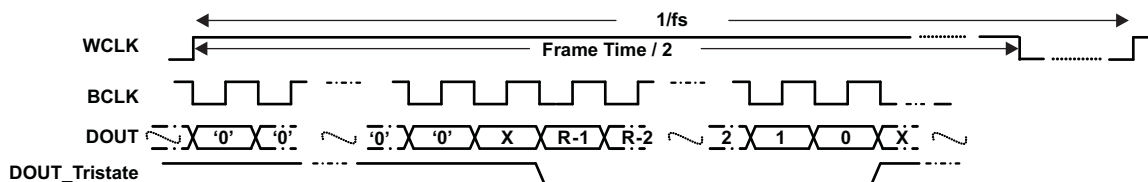

Figure 12. First Channel Disabled, Second Channel Enabled, 3-Stating Enabled

The sync signal for the ADC filter is not generated based on the disabled channel. The sync signal for the filter corresponds to the beginning of the earlier of the two channels. If the first channel is disabled, the filter sync is generated at the beginning of the second channel, if it is enabled. If both the channels are disabled, there is no output to the serial bus, and the filter sync corresponds to the beginning of the frame.

Feature Description (continued)

By default, when the word clocks and bit clocks are generated by the TLV320ADC3101, these clocks are active only when the ADC is powered up within the device. This is done to save power. However, it also supports a feature wherein both the word clocks and bit clocks can be active even when the codec in the device is powered down. This is useful when using the TDM mode with multiple codecs on the same bus or when word clocks or bit clocks are used in the system as general-purpose clocks.

10.3.6.1 Right-Justified Mode

In right-justified mode, the LSB of the left channel is valid on the rising edge of the bit clock preceding the falling edge of word clock. Similarly, the LSB of the right channel is valid on the rising edge of the bit clock preceding the rising edge of the word clock. See [Figure 13](#) for right-justified mode timing.

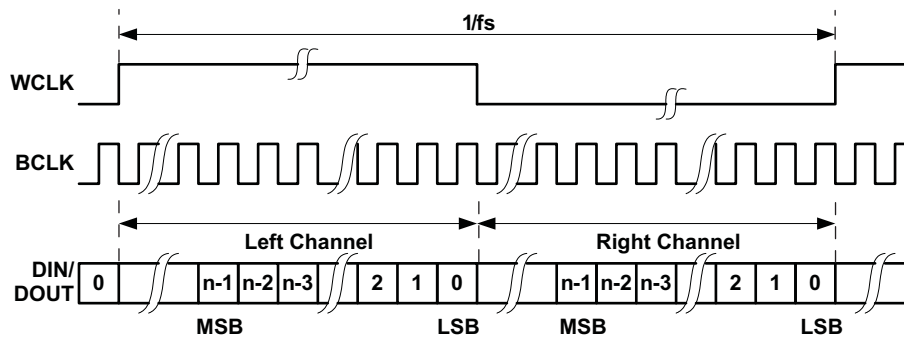

Figure 13. Timing Diagram for Right-Justified Mode

For right-justified mode, the number of bit clocks per frame must be greater than twice the programmed word-length of the data.

NOTE

The time-slot-based mode is not available in the right-justified mode.

10.3.6.2 Left-Justified Mode

In left-justified mode, the MSB of the right channel is valid on the rising edge of the bit clock following the falling edge of the word clock. Similarly, the MSB of the left channel is valid on the rising edge of the bit clock following the rising edge of the word clock. [Figure 14](#) shows the standard timing of the left-justified mode.

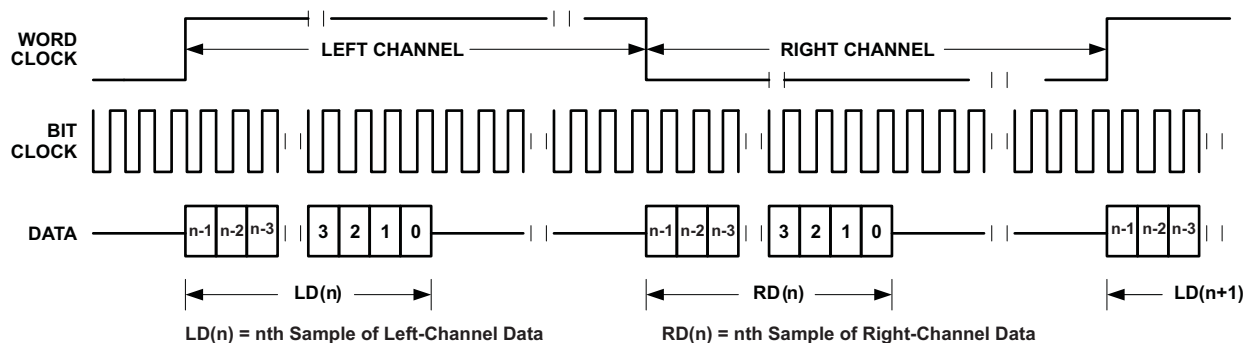

Figure 14. Left-Justified Mode (Standard Timing)

[Figure 15](#) shows the left-justified mode with $Ch_Offset_1 = 1$.

Feature Description (continued)

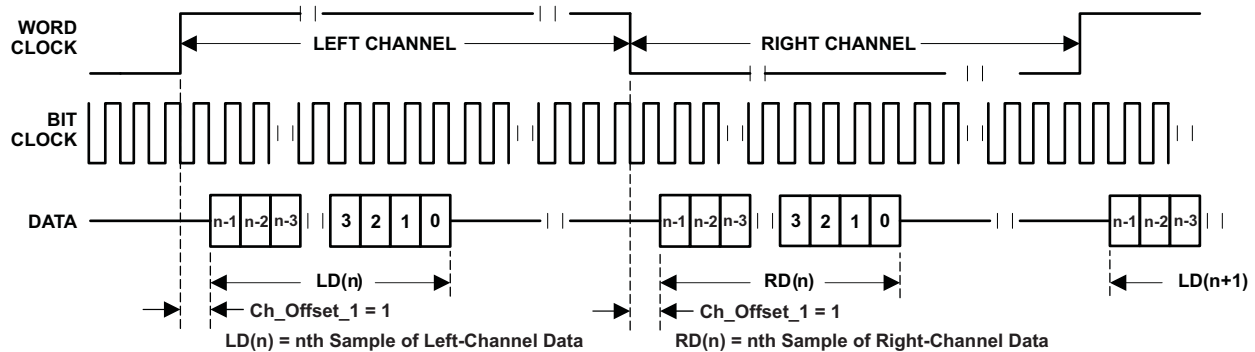

Figure 15. Left-Justified Mode With Ch_Offset_1 = 1

Figure 16 shows the left-justified mode with Ch_Offset_1 = 0 and bit clock inverted.

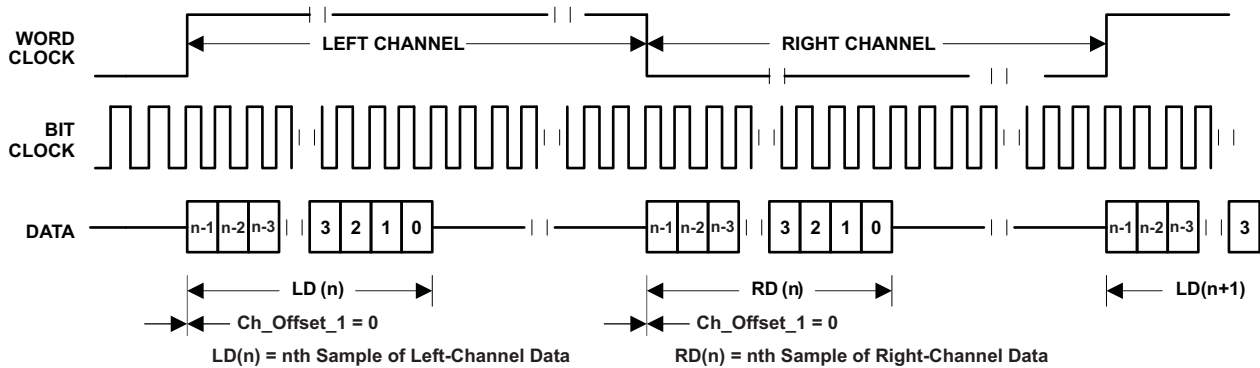
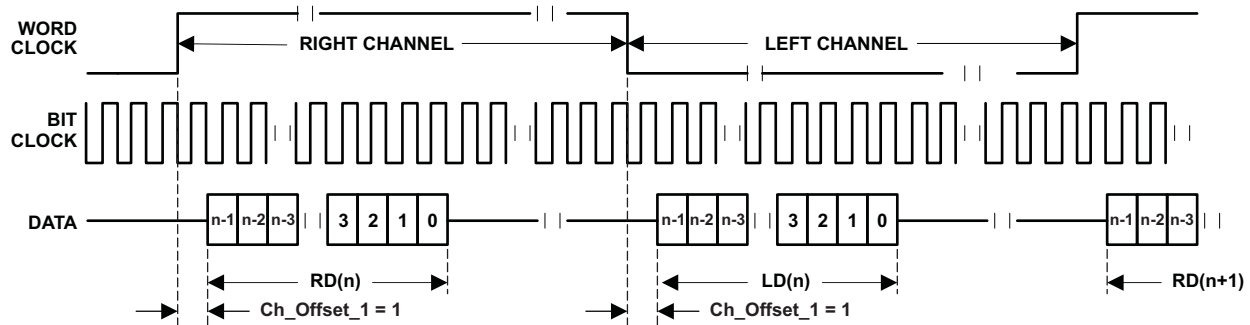

Figure 16. Left-Justified Mode With Ch_Offset_1 = 0, Bit Clock Inverted

For left-justified mode, the number of bit clocks per frame must be greater than twice the programmed word length of the data. Also, the programmed offset value must be less than the number of bit clocks per frame by at least the programmed word length of the data.

When the time-slot-based channel assignment is disabled (page 0 / register 38, bit D0 = 0), the left and right channels have the same offset Ch_Offset_1 (page 0 / register 28), and each edge of the word clock starts data transfer for one of the two channels, depending on whether or not channel swapping is enabled. Data bits are valid on the rising edges of the bit clock. With the time-slot-based channel assignment enabled (page 0 / register 38, bit D0 = 1), the left and right channels have independent offsets (Ch_Offset_1 and Ch_Offset_2). The rising edge of the word clock starts data transfer for the first channel after a delay of its programmed offset (Ch_Offset_1) for this channel. Data transfer for the second channel starts after a delay of its programmed offset (Ch_Offset_2) from the LSB of the first-channel data. The falling edge of the word clock is not used.

With no channel swapping, the MSB of the left channel is valid on the (Ch_Offset_1 + 1)th rising edge of the bit clock following the rising edge of the word clock. And, the MSB of the right channel is valid on the (Ch_Offset_1 + 1)th rising edge of the bit clock following the falling edge of the word clock. The operation in this case, with offset of 1, is shown in the timing diagram of Figure 15. Because channel swapping is not enabled, the left-channel data is before the right-channel data. With channel swapping enabled, the MSB of the right channel is valid on the (Ch_Offset_1 + 1)th rising edge of the bit clock following the rising edge of the word clock. And, the MSB of the left channel is valid on the (Ch_Offset_1 + 1)th rising edge of the bit clock following the falling edge of the word clock. The operation in this case, with offset of 1, is shown in the timing diagram of Figure 17. As shown in the diagram, right-channel data of a frame is before that frame's left-channel data, due to channel swapping. Otherwise, the behavior is similar to the case where channel swapping is disabled. The MSB of the right-channel data is valid on the second rising edge of the bit clock after the rising edge of the word clock, due to an offset of 1. Similarly, the MSB of the left-channel data is valid on the second rising edge of the bit clock after the falling edge of the word clock.

Feature Description (continued)

Figure 17. Left-Justified Mode With Ch_Offset_1 = 1, Channel Swapping Enabled

When time-based-slot mode is enabled with no channel swapping, the MSB of the left channel is valid on the (Offset1 + 1)th rising edge of the bit clock following the rising edge of the word clock. And, the MSB of the right channel is valid on the (Ch_Offset_2 + 1)th rising edge of the bit clock following the LSB of the left channel.

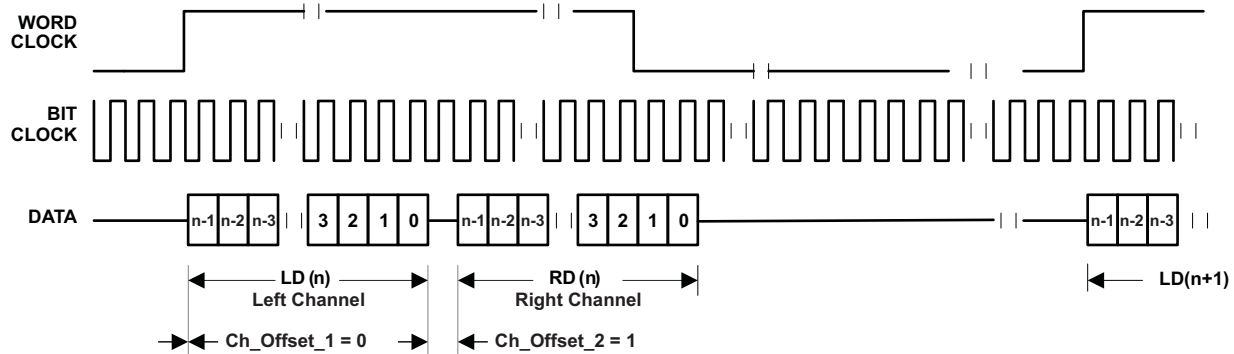
[Figure 18](#) shows the operation with time-based-slot mode enabled and Ch_Offset_1 = 0 and Ch_Offset_2 = 1. The MSB of the left channel is valid on the first rising edge of the bit clock after the rising edge of the word clock. Data transfer for the right channel does not wait for the falling edge of the word clock, and the MSB of the right channel is valid on the second rising edge of the bit clock after the LSB of the left channel.

Figure 18. Left-Justified Mode, Time-Based-Slot Mode Enabled, Ch_Offset_1 = 0, Ch_Offset_2 = 1

For the case with time-based-slot mode enabled and channel swapping enabled, the MSB of the right channel is valid on the (Ch_Offset_1 + 1)th rising edge of the bit clock following the rising edge of the word clock. And, the MSB of the left channel is valid on the (Ch_Offset_2 + 1)th rising edge of the bit clock following the LSB of the right channel. [Figure 19](#) shows the operation in this mode with Ch_Offset_1 = 0 and Ch_Offset_2 = 1. The MSB of the right channel is valid on the first rising edge of the bit clock after the rising edge of the word clock. Data transfer for the left channel starts following the completion of data transfer for the right channel without waiting for the falling edge of the word clock. The MSB of the left channel is valid on the second rising edge of the bit clock after the LSB of the right channel.

Feature Description (continued)

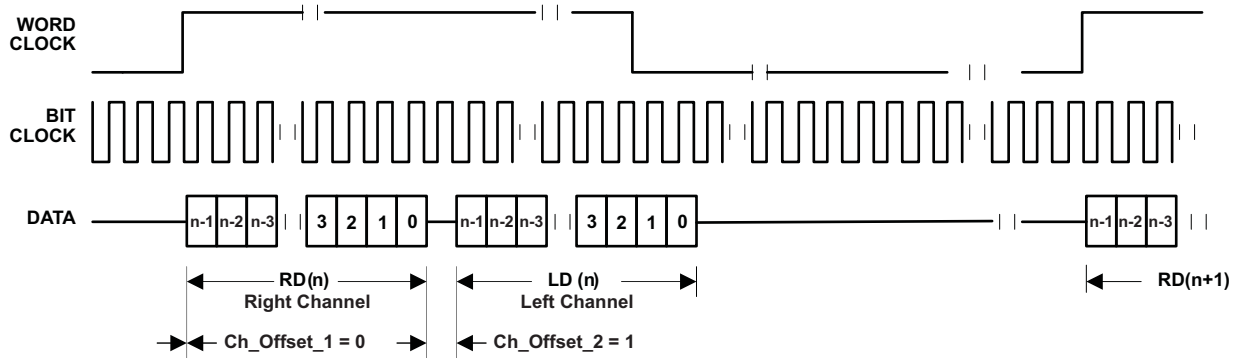

Figure 19. Left-Justified Mode, Time-Based-Slot Mode Enabled, Ch_Offset_1 = 0, Ch_Offset_2 = 1, Channel Swapping Enabled

10.3.6.3 I²S Mode

In I²S mode, the MSB of the left channel is valid on the second rising edge of the bit clock after the falling edge of the word clock. Similarly, the MSB of the right channel is valid on the second rising edge of the bit clock after the rising edge of the word clock. Figure 20 shows the standard I²S timing.

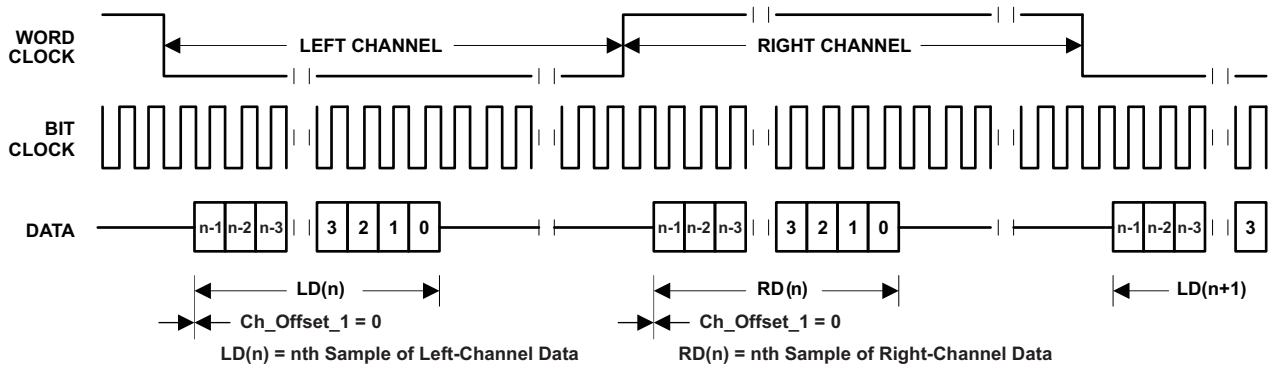

Figure 20. I²S Mode (Standard Timing)

Figure 21 shows the I²S mode timing with Ch_Offset_1 = 2.

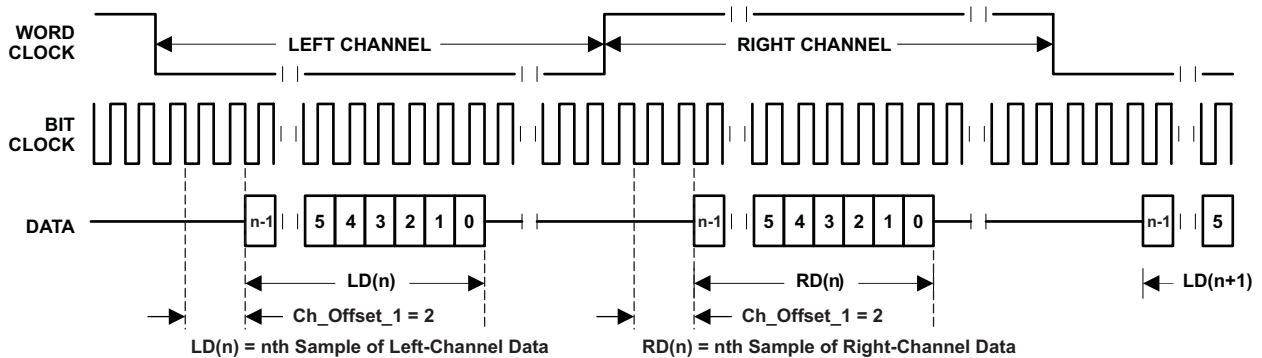

Figure 21. I²S Mode With Ch_Offset_1 = 2

Figure 22 shows the I²S mode timing with Ch_Offset_1 = 0 and bit clock inverted.

Feature Description (continued)

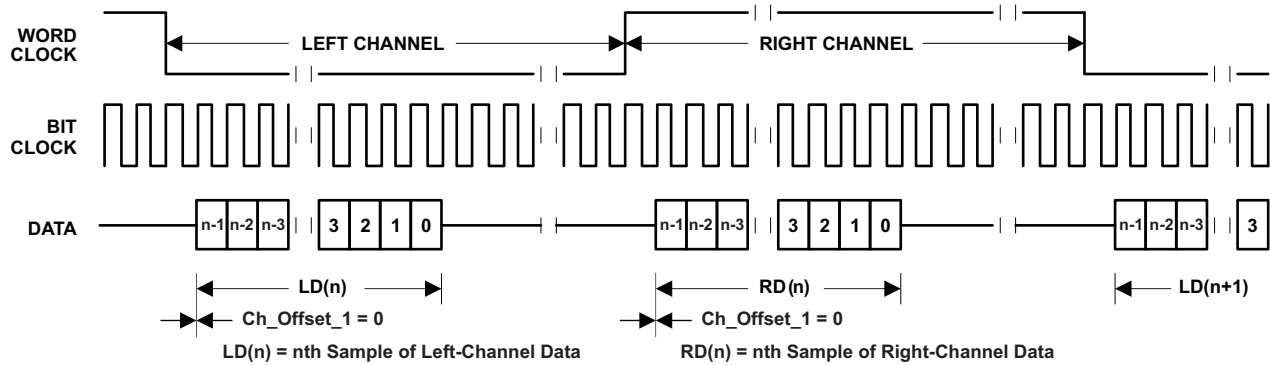

Figure 22. I²S Mode With Ch_Offset_1 = 0, Bit Clock Inverted

For I²S mode, the number of bit clocks per channel must be greater than or equal to the programmed word length of the data. Also the programmed offset value must be less than the number of bit clocks per frame by at least the programmed word length of the data.

10.3.6.4 DSP Mode

In DSP mode, the rising edge of the word clock starts the data transfer with the left-channel data first and is immediately followed by the right-channel data. Each data bit is valid on the falling edge of the bit clock. Figure 23 shows the standard timing for the DSP mode.

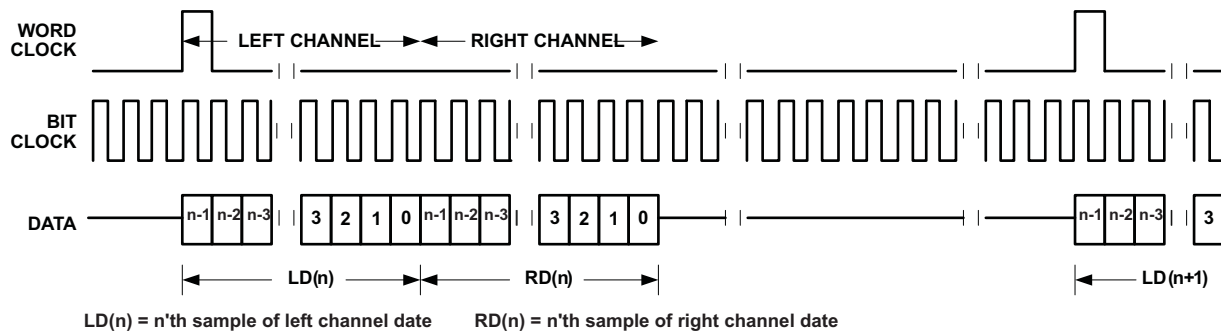

Figure 23. DSP Mode (Standard Timing)

Figure 24 shows the DSP mode timing with Ch_Offset_1 = 1.

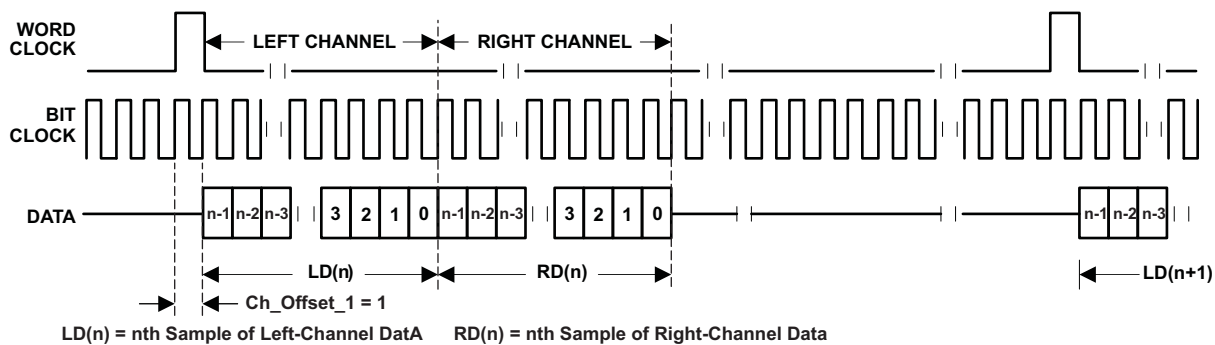

Figure 24. DSP Mode With Ch_Offset_1 = 1

Figure 25 shows the DSP mode timing with Ch_Offset_1 = 0 and bit clock inverted.

Feature Description (continued)

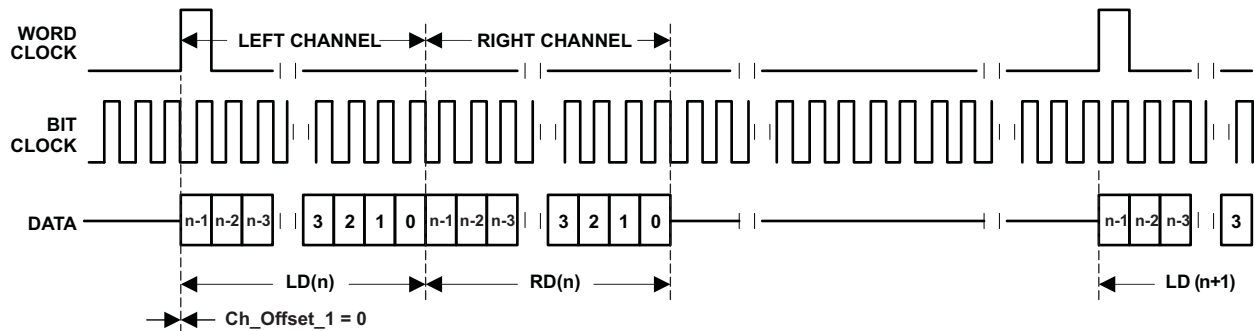

Figure 25. DSP Mode With Ch_Offset_1 = 0, Bit Clock Inverted

For DSP mode, the number of bit clocks per frame must be greater than twice the programmed word length of the data. Also, the programmed offset value must be less than the number of bit clocks per frame by at least the programmed word length of the data.

Figure 26 shows the DSP time-slot-based mode without channel swapping, and with Ch_Offset_1 = 0 and Ch_Offset_2 = 3. The MSB of left channel data is valid on the first falling edge of the bit clock after the rising edge of the word clock. Because the right channel has an offset of 3, the MSB of its data is valid on the third falling edge of the bit clock after the LSB of the left-channel data. As in the case of other modes, the serial output bus is put in the high-impedance state, if 3-stating of the output is enabled, during all the extra bit-clock cycles in the frame.

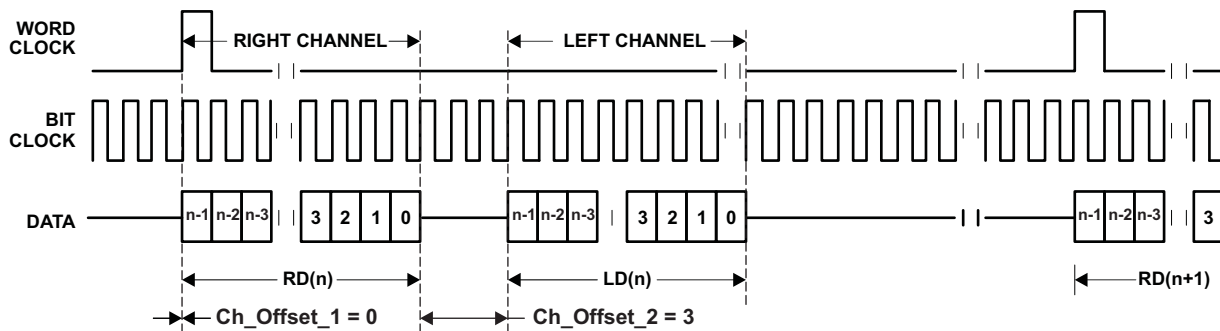

Figure 26. DSP Mode, Time-Slot-Based Mode Enabled, Ch_Offset_1 = 0, Ch_Offset_2 = 3

Figure 27 shows the timing diagram for the DSP mode with left and right channels swapped, Ch_Offset_1 = 0, and Ch_Offset_2 = 3. The MSB of the right channel is valid on the first falling edge of the bit clock after the rising edge of the word clock. And, the MSB of the left channel is valid three bit-clock cycles after the LSB of right channel, because the offset for the left channel is 3.

Feature Description (continued)

Figure 27. DSP Mode, Time-Slot-Based Mode Enabled, Ch_Offset_1 = 0, Ch_Offset_2 = 3, Channel Swap Enabled

10.3.7 Audio Clock Generation

The audio converters in fully programmable filter mode in the TLV320ADC3101 require an internal audio master clock at a frequency of $\geq N \times f_s$, where $N = \text{IADC}$ (page 0 / register 21) when filter mode (page 0 / register 61) equals zero; otherwise, N equals the instruction count from the ADC processing blocks (see [Table 6](#)). The master clock is obtained from an external clock signal applied to the device.

The device can accept an MCLK input from 512 kHz to 50 MHz, which can then be passed through either a programmable divider or a PLL to get the proper internal audio master clock required by the device. The BCLK input can also be used to generate the internal audio master clock.

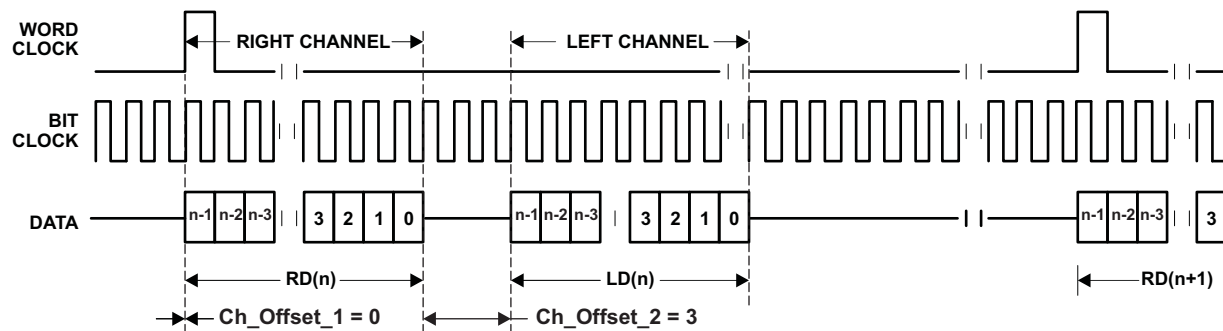
A primary concern is proper operation of the TLV320ADC3101 at various sample rates with the limited MCLK frequencies available in the system. This device includes a programmable PLL to accommodate such situations. The integrated PLL can generate audio clocks from a wide variety of possible MCLK inputs, with particular focus paid to the standard MCLK rates already widely used.

When the PLL is enabled:

$$f_s = (\text{PLLCLK_IN} \times K \times R) / (\text{NADC} \times \text{MADC} \times \text{AOSR} \times P)$$

where

- $P = 1, 2, 3, \dots, 8$
- $R = 1, 2, \dots, 16$
- $K = J.D$
- $J = 1, 2, 3, \dots, 63$
- $D = 0000, 0001, 0002, 0003, \dots, 9998, 9999$
- PLLCLK_IN can be MCLK or BCLK, selected by page 0 / register 4, bits D3–D2. (1)

P , R , J , and D are register programmable. J is the integer portion of K (the numbers to the left of the decimal point), whereas D is the fractional portion of K (the numbers to the right of the decimal point, assuming four digits of precision).

Examples:

If $K = 8.5$, then $J = 8$, $D = 5000$

If $K = 7.12$, then $J = 7$, $D = 1200$

If $K = 14.03$, then $J = 14$, $D = 0300$

If $K = 6.0004$, then $J = 6$, $D = 0004$

When the PLL is enabled and $D = 0000$, the following conditions must be satisfied to meet specified performance:

$$512 \text{ kHz} \leq (\text{PLLCLK_IN} / P) \leq 20 \text{ MHz}$$

$$80 \text{ MHz} \leq (\text{PLLCLK_IN} \times K \times R / P) \leq 110 \text{ MHz}$$

$$4 \leq J \leq 55$$

Feature Description (continued)

When the PLL is enabled and $D \neq 0000$, the following conditions must be satisfied to meet specified performance:

$$10 \text{ MHz} \leq \text{PLLCLK_IN} / P \leq 20 \text{ MHz}$$

$$80 \text{ MHz} \leq \text{PLLCLK_IN} \times K \times R / P \leq 110 \text{ MHz}$$

$$4 \leq J \leq 11$$

$$R = 1$$

Example:

For $\text{MCLK} = 12 \text{ MHz}$, $f_s = 44.1 \text{ kHz}$, $\text{NADC} = 8$, $\text{MADC} = 2$, and $\text{AOSR} = 128$:
 Select $P = 1$, $R = 1$, $K = 7.5264$, which results in $J = 7$, $D = 5264$

Example:

For $\text{MCLK} = 12 \text{ MHz}$, $f_s = 48 \text{ kHz}$, $\text{NADC} = 8$, $\text{MADC} = 2$, and $\text{AOSR} = 128$:
 Select $P = 1$, $R = 1$, $K = 8.192$, which results in $J = 8$, $D = 1920$

Table 1 lists several example cases of typical MCLK rates and how to program the PLL to achieve sample rates of $f_s = 44.1 \text{ kHz}$ or 48 kHz with $\text{NADC} = 8$, $\text{MADC} = 2$, and $\text{AOSR} = 128$.

Table 1. Typical MCLK Rates

MCLK (MHz)	P	R	J	D	ACHIEVED f_s	% ERROR
$f_s = 44.1 \text{ kHz}$						
2.8224	1	1	32	0	44,100.00	0.0000
5.6448	1	1	16	0	44,100.00	0.0000
12.0	1	1	7	5264	44,100.00	0.0000
13.0	1	1	6	9474	44,099.71	-0.0007
16.0	1	1	5	6448	44,100.00	0.0000
19.2	1	1	4	7040	44,100.00	0.0000
19.68	1	1	4	5893	44,100.30	0.0007
48.0	4	1	7	5264	44,100.00	0.0000
$f_s = 48 \text{ kHz}$						
2.048	1	1	48	0	48,000.00	0.0000
3.072	1	1	32	0	48,000.00	0.0000
4.096	1	1	24	0	48,000.00	0.0000
6.144	1	1	16	0	48,000.00	0.0000
8.192	1	1	12	0	48,000.00	0.0000
12.0	1	1	8	1920	48,000.00	0.0000
13.0	1	1	7	5618	47,999.71	-0.0006
16.0	1	1	6	1440	48,000.00	0.0000
19.2	1	1	5	1200	48,000.00	0.0000
19.68	1	1	4	9951	47,999.79	-0.0004
48.0	4	1	8	1920	48,000.00	0.0000

A detailed diagram of the audio clock section of the TLV320ADC3101 is shown in Figure 28.

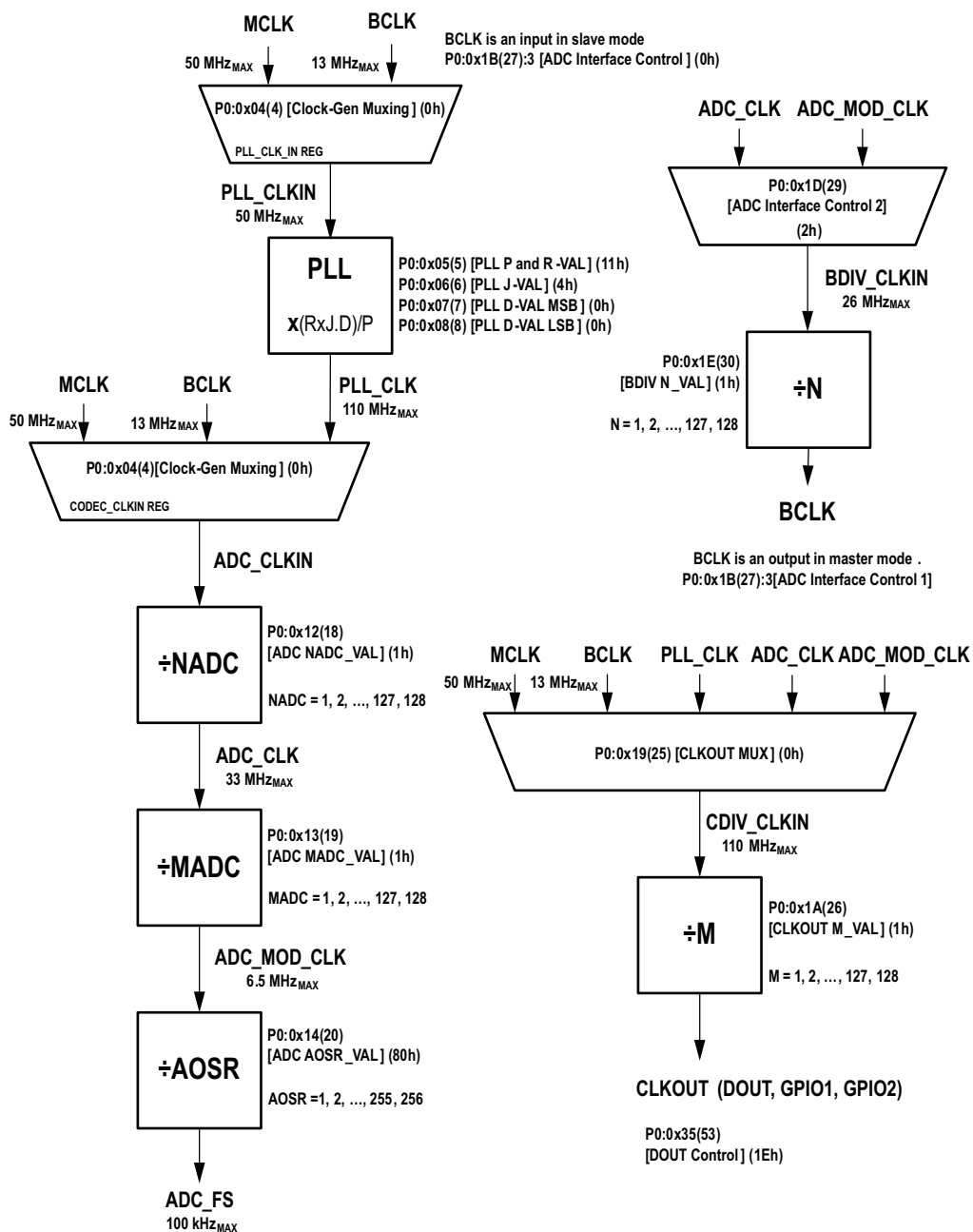

Note:
MADC x AOSR ≥ IADC
Where IADC number of instructions (Instruction Count) for the ADC MAC engine, it is programmable from 2, 4, ..., 510.
Convention:
Page Number: Register Number: (Register Bit) [Register Name] (Reset Value)

Figure 28. Audio Clock Generation Processing

10.3.8 Stereo Audio ADC

The TLV320ADC3101 includes a stereo audio ADC, which uses a delta-sigma modulator with 128-times oversampling in single-rate mode, followed by a digital decimation filter. The ADC supports sampling rates from 8 kHz to 48 kHz in single-rate mode, and up to 96 kHz in dual-rate mode. Whenever the ADC is in operation, the device requires that an audio master clock be provided and appropriate audio clock generation be set up within the device.

In order to provide optimal system power dissipation, the stereo ADC can be powered one channel at a time, to support the case where only mono record capability is required. In addition, both channels can be fully or partially powered down.

The integrated digital decimation filter removes high-frequency content and downsamples the audio data from an initial sampling rate of $128 f_s$ to the final output sampling rate of f_s . The decimation filter provides a linear phase output response with a group delay of $17/f_s$. The -3 dB bandwidth of the decimation filter extends to $0.45 f_s$ and scales with the sample rate (f_s). The filter has minimum 73 dB attenuation over the stop band from $0.55 f_s$ to $64 f_s$. Independent digital high-pass filters are also included with each ADC channel, with a corner frequency that can be set independently by programmable coefficients or can be disabled entirely.

Because of the oversampling nature of the audio ADC and the integrated digital decimation filtering, requirements for analog anti-aliasing filtering are relaxed. The TLV320ADC3101 integrates a second-order analog anti-aliasing filter with 20-dB attenuation at 1 MHz. This filter, combined with the digital decimation filter, provides sufficient anti-aliasing filtering without requiring additional external components.

The ADC is preceded by a programmable gain amplifier (PGA), which allows analog gain control from 0 dB to 40 dB in steps of 0.5 dB. The PGA gain changes are implemented with an internal soft-stepping algorithm that only changes the actual volume level by one 0.5-dB step every one or two ADC output samples, depending on the register programming (see register page 0 / register 81). This soft-stepping specifies that volume control changes occur smoothly with no audible artifacts. On reset, the PGA gain defaults to a mute condition, and upon power down, the PGA soft-steps the volume to mute before shutting down. A read-only flag is set whenever the gain applied by PGA equals the desired value set by the register. The soft-stepping control can also be disabled by programming a register bit.

10.3.9 Audio Analog Inputs

10.3.9.1 Digital Volume Control

The TLV320ADC3101 also has a digital volume-control block with a range from -12 dB to 20 dB in steps of 0.5 dB. It is set by programming page 0 / register 83 and page 0 / register 84 for the left and right channels, respectively.

Table 2. Digital Volume Control for ADC

DESIRED GAIN dB	LEFT / RIGHT CHANNEL PAGE 0 / REGISTER 83 AND PAGE 0 / REGISTER 84, BITS D6–D0
-12	110 1000
-11.5	110 1001
-11	110 1010
...	...
-0.5	111 1111
0	000 0000 (default)
0.5	000 0001
...	...
19.5	010 0111
20	010 1000

During volume control changes, the soft-stepping feature is used to avoid audible artifacts. The soft-stepping rate can be set to either 1 or 2 gain steps per sample. Soft-stepping can also be entirely disabled. This soft-stepping is configured via page 0 / register 81, bits D1–D0, and is common to soft-stepping control for the analog PGA. During power-down of an ADC channel, this volume control soft-steps down to –12 dB before powering down. Due to the soft-stepping control, soon after changing the volume control setting or powering down the ADC channel, the actual applied gain may be different from the one programmed through the control register. The TLV320ADC3101 gives feedback to the user through the read-only flags in page 0 / register 36, bit D7 for the left channel and page 0 / register 36, bit D3 for the right channel.

10.3.9.2 Fine Digital Gain Adjustment

Additionally, the gain in each of the channels is finely adjustable in steps of 0.1 dB. This is useful when trying to match the gain between channels. By programming page 0 / register 82, the gain can be adjusted from 0 dB to –0.4 dB in steps of 0.1 dB. This feature, in combination with the regular digital volume control, allows the gains through the left and right channels be matched in the range of –0.5 dB to 0.5 dB with a resolution of 0.1 dB.

10.3.9.3 AGC

The TLV320ADC3101 includes automatic gain control (AGC) for ADC recording. AGC can be used to maintain a nominally constant output level when recording speech. As opposed to manually setting the PGA gain, in the AGC mode, the circuitry automatically adjusts the PGA gain as the input signal becomes overly loud or very weak, such as when a person speaking into a microphone moves closer to or farther from the microphone. The AGC algorithm has several programmable parameters, including target gain, attack and decay time constants, noise threshold, and maximum PGA applicable, that allow the algorithm to be fine-tuned for any particular application. The algorithm uses the absolute average of the signal (which is the average of the absolute value of the signal) as a measure of the nominal amplitude of the output signal. Because the gain can be changed at the sample interval time, the AGC algorithm operates at the ADC sample rate.

- **Target level** represents the nominal output level at which the AGC attempts to hold the ADC output signal level. The TLV320ADC3101 allows programming of eight different target levels, which can be programmed from –5.5 dB to –24 dB relative to a full-scale signal. Because the TLV320ADC3101 reacts to the signal absolute average and not to peak levels, it is recommended that the target level be set with enough margin to avoid clipping at the occurrence of loud sounds.
- **Attack time** determines how quickly the AGC circuitry reduces the PGA gain when the output signal level exceeds the target level due to an increase in input signal level. A wide range of attack-time programmability is supported in terms of number of samples (that is, number of ADC sample-frequency clock cycles).
- **Decay time** determines how quickly the PGA gain is increased when the output signal level falls below the target level due to a reduction in input signal level. A wide range of decay-time programmability is supported in terms of number of samples (that is, number of ADC sample-frequency clock cycles).
- **Noise threshold.** If the input signal level falls below the noise threshold, the AGC considers it as silence, and thus brings down the gain to 0 dB in steps of 0.5 dB every sample period and sets the noise-threshold flag. The gain stays at 0 dB unless the input signal average rises above the noise threshold setting. This keeps noise from being amplified in the absence of signal. Noise threshold level in the AGC algorithm is programmable from –30 dB to –90 dB of full scale. When the AGC noise threshold is set to –70 dB, –80 dB, or –90 dB, the microphone input maximum PGA applicable setting must be greater than or equal to 11.5 dB, 21.5 dB, or 31.5 dB, respectively. This operation includes hysteresis and debounce to prevent the AGC gain from cycling between high gain and 0 dB when signals are near the noise threshold level. The noise (or silence) detection feature can be entirely disabled by the user.
- **Maximum PGA applicable** allows the designer to restrict the maximum gain applied by the AGC. This can be used for limiting PGA gain in situations where environmental noise is greater than the programmed noise threshold. Microphone input maximum PGA can be programmed from 0 dB to 40 dB in steps of 0.5 dB.
- **Hysteresis**, as the name suggests, determines a window around the noise threshold which must be exceeded to detect that the recorded signal is indeed either noise or signal. If initially the energy of the recorded signal is greater than the noise threshold, then the AGC recognizes it as noise only when the energy of the recorded signal falls below the noise threshold by a value given by hysteresis. Similarly, after the recorded signal is recognized as noise, for the AGC to recognize it as a signal, its energy must exceed the noise threshold by a value given by the hysteresis setting. In order to prevent the AGC from jumping between noise and signal states, (which can happen when the energy of recorded signal is very close to the noise threshold) a non-zero hysteresis value must be chosen. The hysteresis feature can also be disabled.
- **Debounce time (noise and signal)** determines the hysteresis in time domain for noise detection. The AGC

continuously calculates the energy of the recorded signal. If the calculated energy is less than the set noise threshold, then the AGC does not increase the input gain to achieve the target level. However, to handle audible artifacts which can occur when the energy of the input signal is very close to the noise threshold, the AGC checks if the energy of the recorded signal is less than the noise threshold for a time greater than the noise debounce time. Similarly, the AGC starts increasing the input-signal gain to reach the target level when the calculated energy of the input signal is greater than the noise threshold. Again, to avoid audible artifacts when the input-signal energy is very close to noise threshold, the energy of the input signal must continuously exceed the noise threshold value for the signal debounce time. If the debounce times are kept very small, then audible artifacts can result by rapidly enabling and disabling the AGC function. At the same time, if the debounce time is kept too large, then the AGC may take time to respond to changes in levels of input signals with respect to noise threshold. Both noise and signal debounce time can be disabled.

- The **AGC noise threshold flag** is a read-only flag indicating that the input signal has levels lower than the noise threshold, and thus is detected as noise (or silence). In such a condition, the AGC applies a gain of 0 dB.
- **Gain applied by AGC** is a read-only register setting which gives a real-time feedback to the system on the gain applied by the AGC to the recorded signal. This, along with the target setting, can be used to determine the input signal level. In a steady state situation

$$\text{Target level (dB)} = \text{gain applied by AGC (dB)} + \text{input signal level (dB)}$$

When the AGC noise threshold flag is set, then the status of gain applied by AGC is not valid.

- The **AGC saturation flag** is a read-only flag indicating that the ADC output signal has not reached its target level. However, the AGC is unable to increase the gain further because the required gain is higher than the maximum allowed PGA gain. Such a situation can happen when the input signal has very low energy and the noise threshold is also set very low. When the AGC noise threshold flag is set, the status of the AGC saturation flag must be ignored.
- The **ADC saturation flag** is a read-only flag indicating an overflow condition in the ADC channel. On overflow, the signal is clipped and distortion results. This typically happens when the AGC target level is kept very high and the energy in the input signal increases faster than the attack time.
- An **AGC low-pass filter** is used to help determine the average level of the input signal. This average level is compared to the programmed detection levels in the AGC to provide the correct functionality. This low-pass filter is in the form of a first-order IIR filter. Two 8-bit registers are used to form the 16-bit digital coefficient, as shown on the register map. In this way, a total of 6 registers are programmed to form the three IIR coefficients. The transfer function of the filter implemented for signal-level detection is given by

$$H(z) = \frac{N_0 + N_1 z^{-1}}{2^{15} - D_1 z^{-1}}$$

where

- Coefficient N0 can be programmed by writing into page 4 / register 2 and page 4 / register 3.
- Coefficient N1 can be programmed by writing into page 4 / register 4 and page 4 / register 5.
- Coefficient D1 can be programmed by writing into page 4 / register 6 and page 4 / register 7.
- N0, N1, and D1 are 16-bit 2s-complement numbers, and their default values implement a low-pass filter with cutoff at $0.002735 \times \text{ADC}_{f_s}$. (2)

See [Table 3](#) for various AGC programming options. AGC can be used only if the analog microphone input is routed to the ADC channel.

Table 3. AGC Parameter Settings

FUNCTION	CONTROL REGISTER LEFT ADC	CONTROL REGISTER RIGHT ADC	BIT
AGC enable	Page 0 / register 86	Page 0 / register 94	D7
Target level	Page 0 / register 86	Page 0 / register 94	D6–D4
Hysteresis	Page 0 / register 87	Page 0 / register 95	D7–D6
Noise threshold	Page 0 / register 87	Page 0 / register 95	D5–D1
Maximum PGA applicable	Page 0 / register 88	Page 0 / register 96	D6–D0
Time constants (attack time)	Page 0 / register 89	Page 0 / register 97	D7–D0
Time constants (decay time)	Page 0 / register 90	Page 0 / register 98	D7–D0

Table 3. AGC Parameter Settings (continued)

FUNCTION	CONTROL REGISTER LEFT ADC	CONTROL REGISTER RIGHT ADC	BIT
Debounce time (noise)	Page 0 / register 91	Page 0 / register 99	D4–D0
Debounce time (signal)	Page 0 / register 92	Page 0 / register 100	D3–D0
Gain applied by AGC	Page 0 / register 93	Page 0 / register 101	D7–D0 (read-only)
AGC noise-threshold flag	Page 0 / register 45 (sticky flag), Page 0 / register 47 (non-sticky flag)	Page 0 / register 45 (sticky flag), Page 0 / register 47 (non-sticky flag)	D6–D5 (read-only)
AGC saturation flag	Page 0 / register 36 (sticky flag)	Page 0 / register 36 (sticky flag)	D5, D1 (read-only)
ADC saturation flag	Page 0 / register 42 (sticky flag), Page 0 / register 43 (non-sticky flag)	Page 0 / register 42 (sticky flag), Page 0 / register 43 (non-sticky flag)	D3–D2 (read-only)

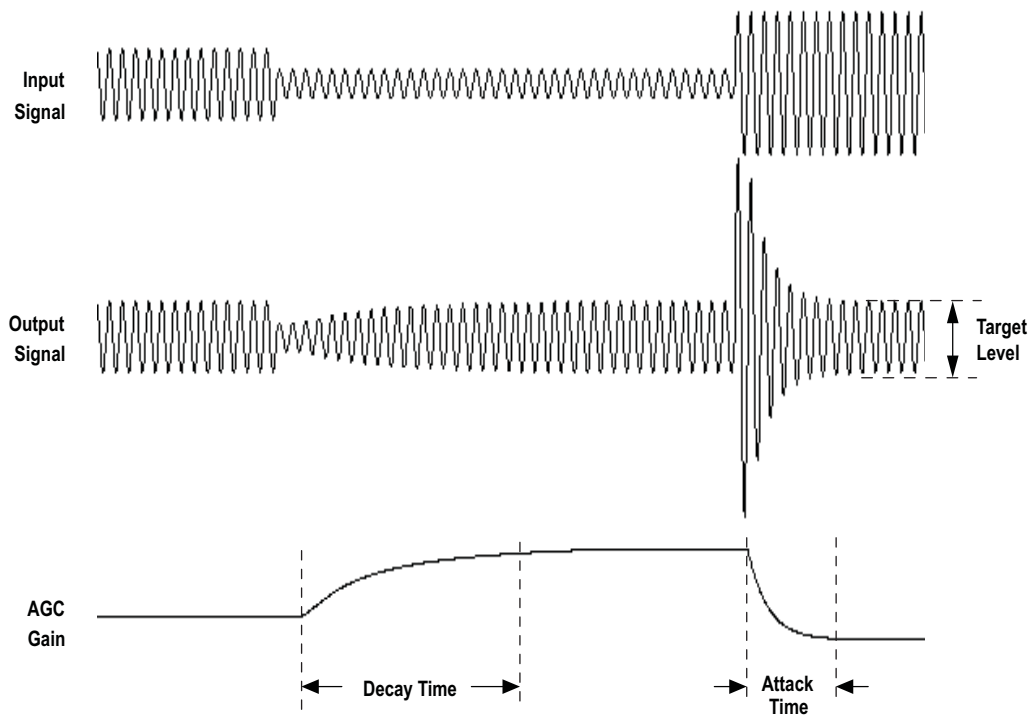
Figure 29. AGC Characteristics

The TLV320ADC3101 includes three analog audio input pins, which can be configured as one fully-differential pair and one single-ended input, or as three single-ended audio inputs. These pins connect through series resistors and switches to the virtual ground terminals of two fully differential operational amplifiers (one per ADC/PGA channel). By selecting to turn on only one set of switches per operational amplifier at a time, the inputs can be effectively multiplexed to each ADC PGA channel.

By selecting to turn on multiple sets of switches per operational amplifier at a time, mixing can also be achieved. Mixing of multiple inputs can easily lead to PGA outputs that exceed the range of the internal operational amplifiers, resulting in saturation and clipping of the mixed output signal. Whenever mixing is being implemented, the user must take adequate precautions to avoid such a saturation case from occurring. In general, the mixed signal must not exceed $2 V_{pp}$ (single-ended) or $4 V_{pp}$ (differential).

In most mixing applications, there is also a general need to adjust the levels of the individual signals being mixed. For example, if a soft signal and a large signal are to be mixed and played together, the soft signal generally must be amplified to a level comparable to the large signal before mixing. In order to accommodate this need, the TLV320ADC3101 includes input level control on each of the individual inputs before they are mixed or multiplexed into the ADC PGAs, with programmable attenuation at 0 dB, –6 dB, or off.

NOTE

This input-level control is not intended to be a volume control, but instead used for coarse level setting. Finer soft-stepping of the input level is implemented in this device by the ADC PGA.

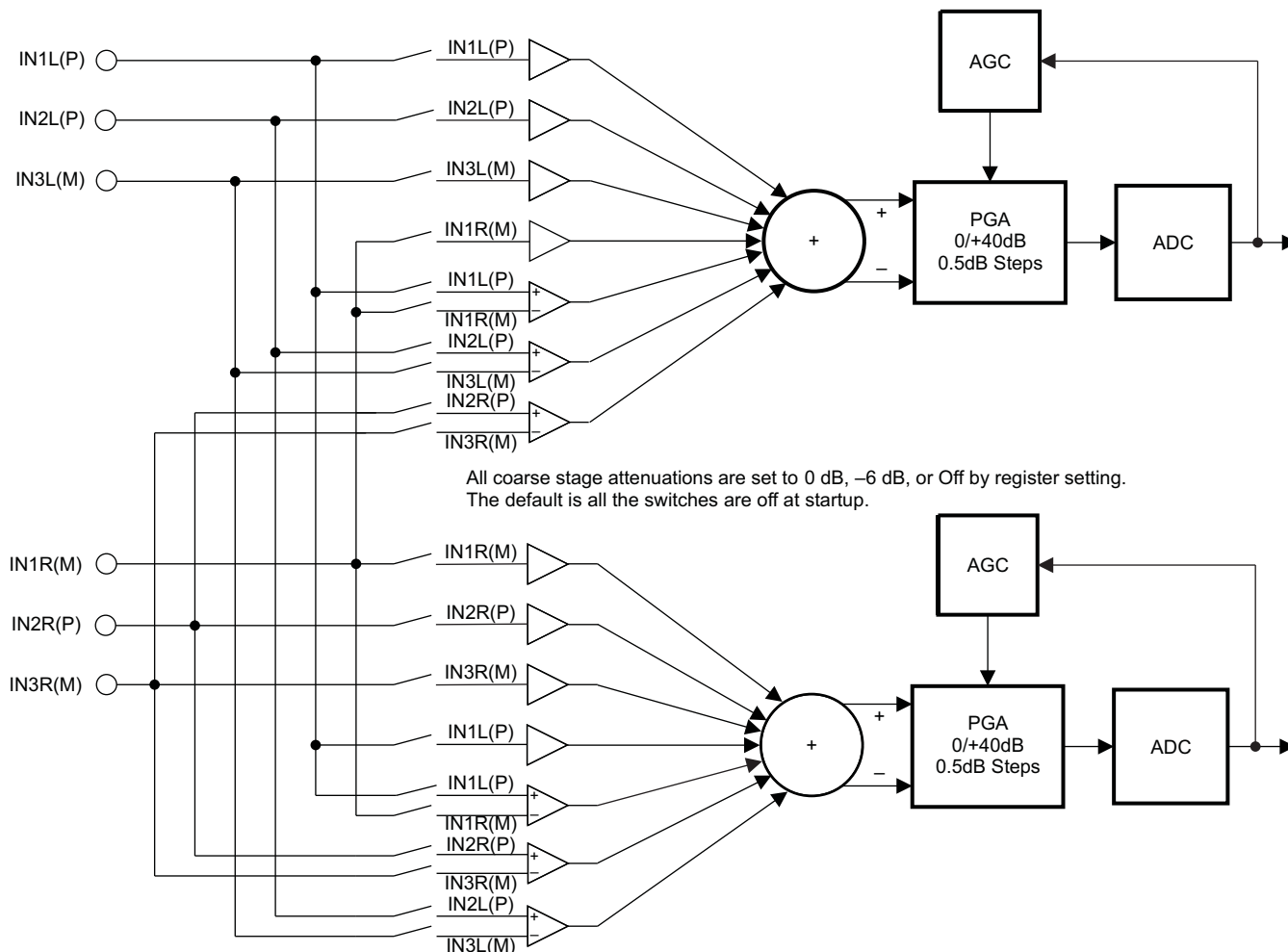

Figure 30. TLV320ADC3101 Available Audio Input Path Configurations

Table 4. TLV320ADC3101 Audio Signals

AUDIO SIGNALS AVAILABLE TO LEFT ADC		AUDIO SIGNALS AVAILABLE TO RIGHT ADC	
SINGLE-ENDED INPUTS	DIFFERENTIAL INPUTS	SINGLE-ENDED INPUTS	DIFFERENTIAL INPUTS
IN1L(P)	IN1L(P), IN1R(M)	IN1R(M)	IN1L(P), IN1R(M)
IN2L(P)	IN2L(P), IN3L(M)	IN2R(P)	IN2R(P), IN3R(M)
IN3L(M)	IN2R(P), IN3R(M)	IN3R(M)	IN2L(P), IN3L(M)
IN1R(M)		IN1L(P)	

Inputs can be selected as single-ended instead of fully differential, and mixing or multiplexing into the ADC PGAs is also possible in this mode. It is not possible, however, for an input pair to be selected as fully-differential for connection to one ADC PGA and simultaneously selected as single-ended for connection to the other ADC PGA channel. However, it is possible for an input to be selected or mixed into both left and right channel PGAs, as long as it has the same configuration for both channels (either both single-ended or both fully differential).

10.3.10 Input Impedance and VCM Control

The TLV320ADC3101 includes several programmable settings to control analog input pins, particularly when they are not selected for connection to an ADC PGA. The default option allows unselected inputs to be put into a high-impedance state, such that the input impedance seen looking into the device is extremely high. However, the pins on the device do include protection diode circuits connected to AVDD and AVSS. Thus, if any voltage is driven onto a pin approximately one diode drop (~0.6 V) above AVDD or one diode drop below AVSS, these protection diodes will begin conducting current, resulting in an effective impedance that no longer appears as a high-impedance state.

Another programmable option for unselected analog inputs is to weakly hold them at the common-mode input voltage of the ADC PGA (which is determined by an internal band-gap voltage reference). This is useful to keep the AC-coupling capacitors connected to analog inputs biased up at a normal dc level, thus avoiding the need for them to charge up suddenly when the input is changed from being unselected to selected for connection to an ADC PGA. This option is controlled in page 1 / register 52 through page 1 / register 57. The user must make sure this option is disabled when an input is selected for connection to an ADC PGA or selected for the analog input bypass path, because it can corrupt the recorded input signal if left operational when an input is selected.

In most cases, the analog input pins on the TLV320ADC3101 must be AC-coupled to analog input sources, the only exception to this generally being if an ADC is being used for dc voltage measurement. The AC-coupling capacitor causes a high-pass filter pole to be inserted into the analog signal path, so the size of the capacitor must be chosen to move that filter pole sufficiently low in frequency to cause minimal effect on the processed analog signal. The input impedance of the analog inputs, when selected for connection to an ADC PGA, varies with the setting of the input-level control, starting at approximately 35 k Ω with an input-level control setting of 0 dB, and 62.5-k Ω when the input-level control is set at -6 dB. For example, using a 0.1- μ F AC-coupling capacitor at an analog input results in a high-pass filter pole of 45.5 Hz when the 0-dB input-level control setting is selected. To set a high-pass corner for the application, the following input-impedance table has been provided with various mixer gains and microphone PGA ranges.

Table 5. Single-Ended Input Impedance vs PGA Ranges ⁽¹⁾

MIXER GAIN (dB)	MICROPHONE PGA RANGE (dB)	INPUT IMPEDANCE (Ω)
0	0–5.5	35,000
0	6–11.5	38,889
0	12–17.5	42,000
0	18–23.5	44,074
0	24–29.5	45,294
0	30–35.5	45,960
0	36–40	46,308
-6	0–5.5	62,222
-6	6–11.5	70,000
-6	12–17.5	77,778
-6	18–23.5	84,000
-6	24–29.5	88,148
-6	30–35.5	90,588
-6	36–40	91,919

(1) Valid when only one input is enabled

10.3.11 MICBIAS Generation

The TLV320ADC3101 includes two programmable microphone bias outputs (MICBIAS1, MICBIAS2), each capable of providing output voltages of 2 V or 2.5 V (both derived from the on-chip band-gap voltage) with 4-mA output-current drive capability. In addition, the MICBIAS outputs may be programmed to be switched to AVDD directly through an on-chip switch, or it can be powered down completely when not needed, for power savings. This function is controlled by register programming in page 1 / register 51.

10.3.12 ADC Decimation Filtering and Signal Processing

The TLV320ADC3101 ADC channel includes a built-in digital decimation filter to process the oversampled data from the delta-sigma modulator to generate digital data at the Nyquist sampling rate with high dynamic range. The decimation filter can be chosen from three different types, depending on the required frequency response, group delay and sampling rate.

10.3.12.1 Processing Blocks

The TLV320ADC3101 offers a range of processing blocks which implement various signal processing capabilities along with decimation filtering. These processing blocks give users the choice of how much and what type of signal processing they may use and which decimation filter is applied.

The signal processing blocks available are:

- First-order IIR
- Scalable number of biquad filters
- Variable-tap FIR filter
- AGC

The processing blocks are tuned for common cases and can achieve high anti-alias filtering or low group delay in combination with various signal processing effects such as audio effects and frequency shaping. The available first-order IIR, biquad, and FIR filters have fully user-programmable coefficients. ADC processing blocks can be selected by writing to page 0 / register 61. The default (reset) processing block is PRB_R1.

Table 6. ADC Processing Blocks

PROCESSING BLOCKS	CHANNEL	DECIMATION FILTER	FIRST-ORDER IIR AVAILABLE	NUMBER OF BIQUADS	FIR	REQUIRED AOSR VALUE	INSTRUCTION COUNT
PRB_R1	Stereo	A	Yes	0	No	128, 64	188
PRB_R2	Stereo	A	Yes	5	No	128, 64	240
PRB_R3	Stereo	A	Yes	0	25-tap	128, 64	236
PRB_R4	Right	A	Yes	0	No	128, 64	96
PRB_R5	Right	A	Yes	5	No	128, 64	120
PRB_R6	Right	A	Yes	0	25-tap	128, 64	120
PRB_R7	Stereo	B	Yes	0	No	64	88
PRB_R8	Stereo	B	Yes	3	No	64	120
PRB_R9	Stereo	B	Yes	0	20-tap	64	128
PRB_R10	Right	B	Yes	0	No	64	46
PRB_R11	Right	B	Yes	3	No	64	60
PRB_R12	Right	B	Yes	0	20-tap	64	64
PRB_R13	Right	C	Yes	0	No	32	70
PRB_R14	Stereo	C	Yes	5	No	32	124
PRB_R15	Stereo	C	Yes	0	25-tap	32	120
PRB_R16	Right	C	Yes	0	No	32	36
PRB_R17	Right	C	Yes	5	No	32	64
PRB_R18	Right	C	Yes	0	25-tap	32	62

10.3.12.2 Processing Blocks – Details

10.3.12.2.1 First-Order IIR, AGC, Filter A

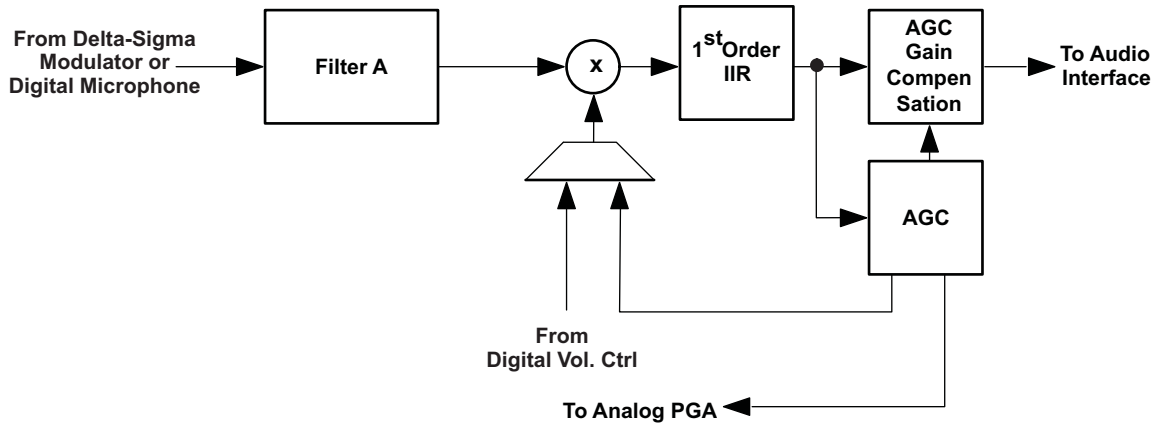

Figure 31. Signal Chain for PRB_R1 and PRB_R4

10.3.12.2.2 Five Biquads, First-Order IIR, AGC, Filter A

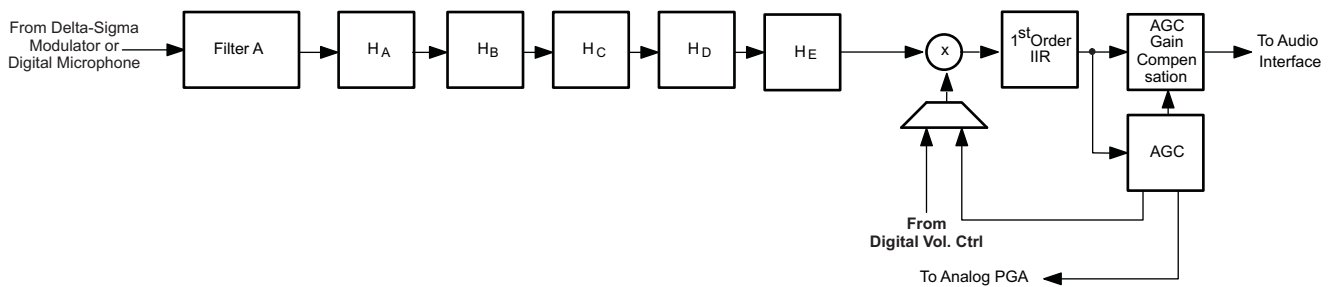

Figure 32. Signal Chain for PRB_R2 and PRB_R5

10.3.12.2.3 25-Tap FIR, First-Order IIR, AGC, Filter A

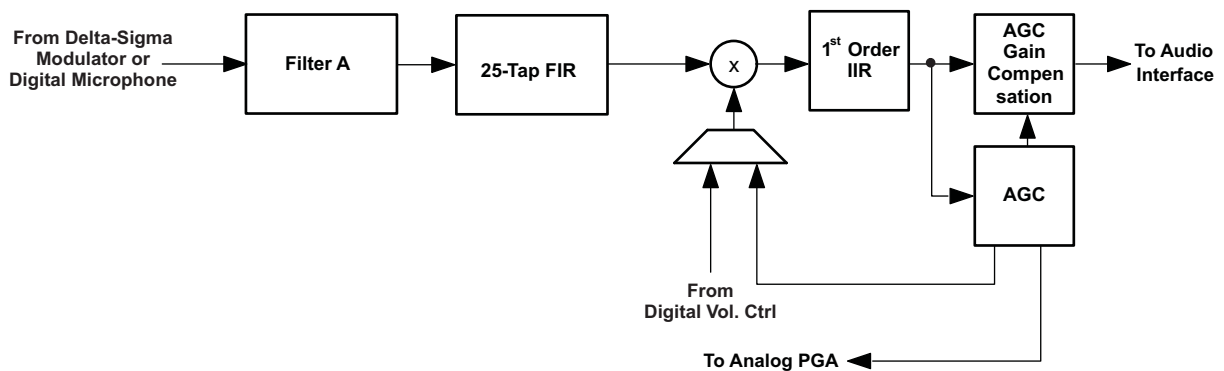

Figure 33. Signal Chain for PRB_R3 and PRB_R6

10.3.12.2.4 First-Order IIR, AGC, Filter B

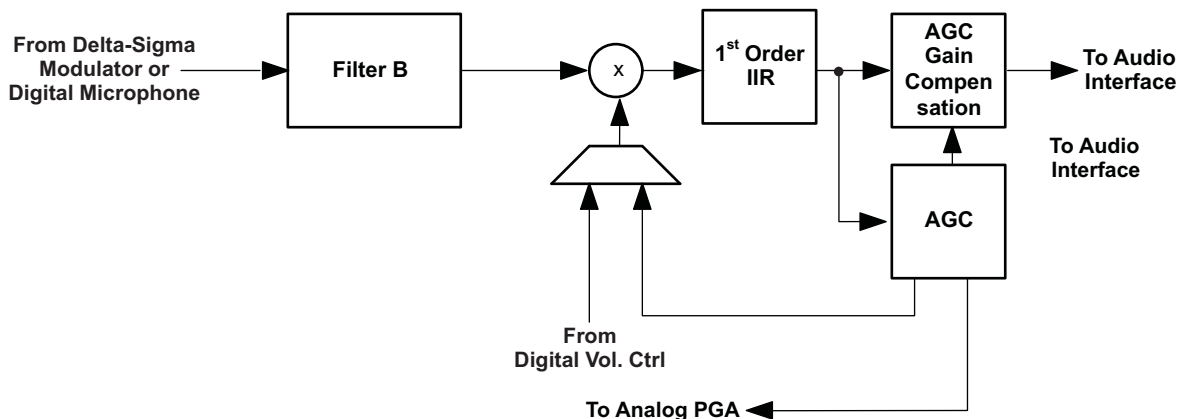

Figure 34. Signal Chain for PRB_R7 and PRB_R10

10.3.12.2.5 Three Biquads, First-Order IIR, AGC, Filter B

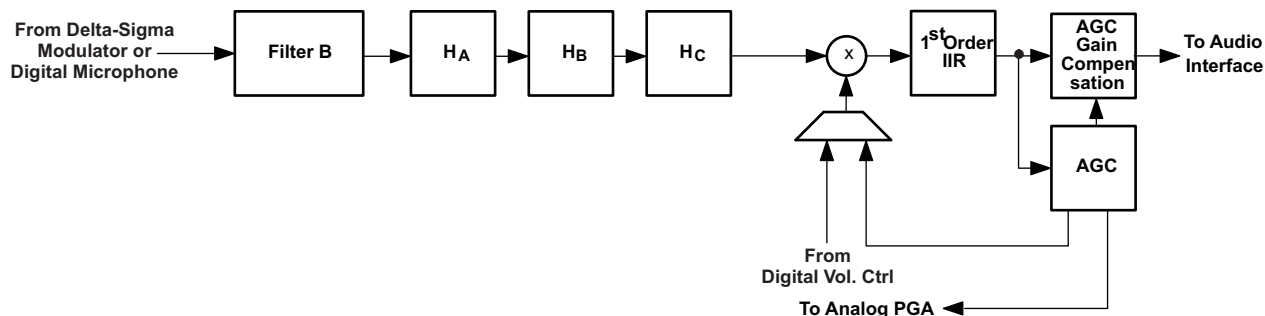

Figure 35. Signal Chain for PRB_R8 and PRB_R11

10.3.12.2.6 20-Tap FIR, First-Order IIR, AGC, Filter B

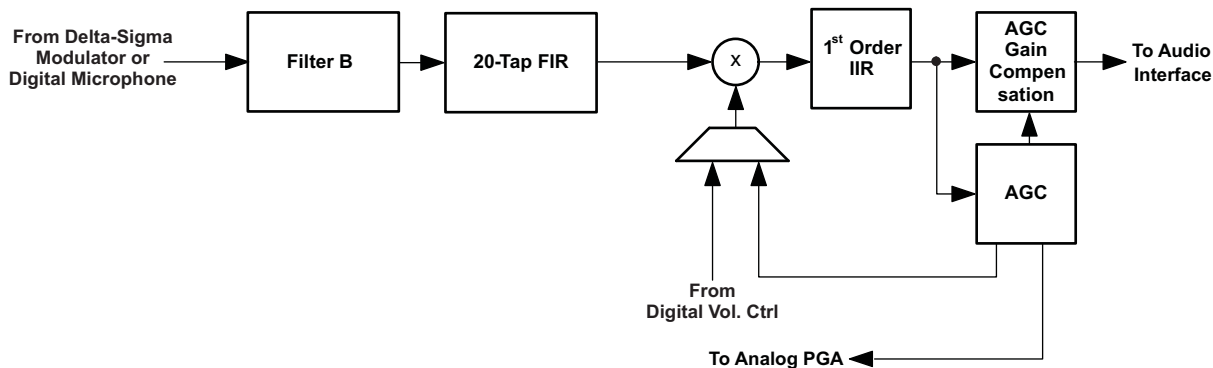
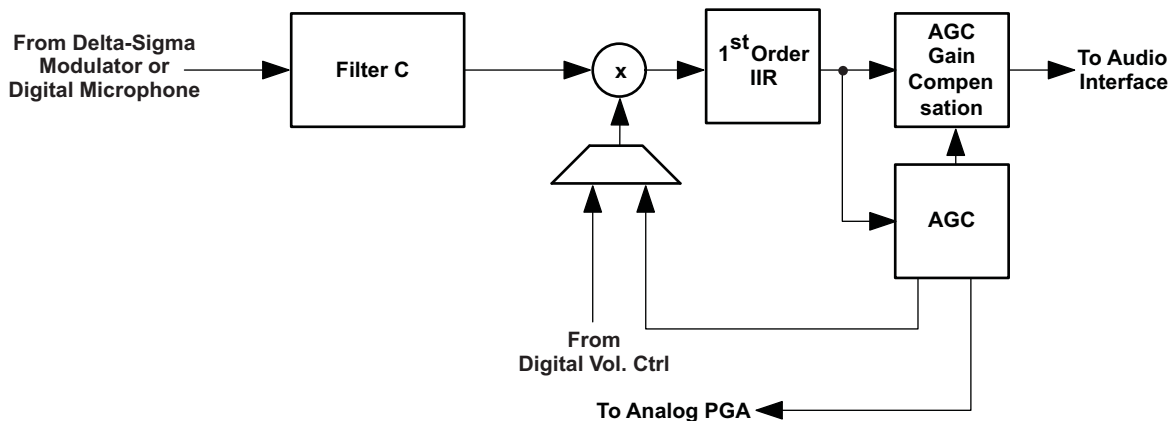
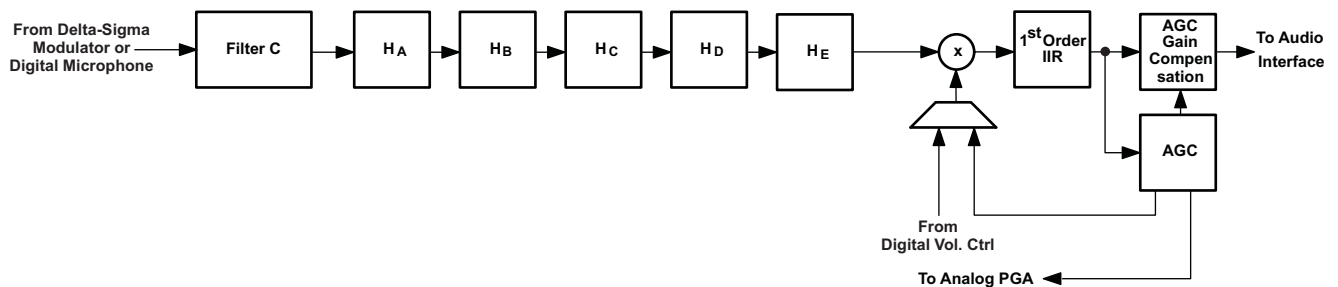
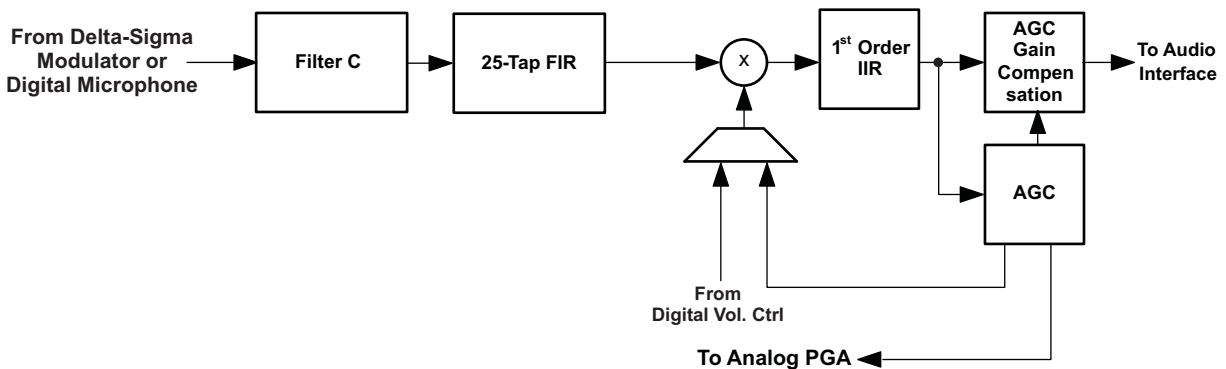

Figure 36. Signal Chain for PRB_R9 and PRB_R12

10.3.12.2.7 First-Order IIR, AGC, Filter C

Figure 37. Signal Chain for PRB_R13 and PRB_R16
10.3.12.2.8 Five Biquads, First-Order IIR, AGC, Filter C

Figure 38. Signal Chain for PRB_R14 and PRB_R17
10.3.12.2.9 25-Tap FIR, First-Order IIR, AGC, Filter C

Figure 39. Signal for PRB_R15 and PRB_R18
10.3.12.3 User-Programmable Filters

Depending on the selected processing block, different types and orders of digital filtering are available. A first-order IIR filter is always available, and is useful to filter out possible dc components of the signal efficiently. Up to five biquad sections, or alternatively up to 25-tap FIR filters, are available for specific processing blocks. The coefficients of the available filters are arranged as sequentially indexed coefficients in two banks. If adaptive filtering is chosen, the coefficient banks can be switched while the processor is running.

The coefficients of these filters are each 16 bits wide, in 2s-complement format, and occupy two consecutive 8-bit registers in the register space, as shown in Table 7. Specifically, the filter coefficients are in 1.15 (one dot 15) format with a range from -1.0 (0x8000) to 0.999969482421875 (0x7FFF), as shown in Figure 40.

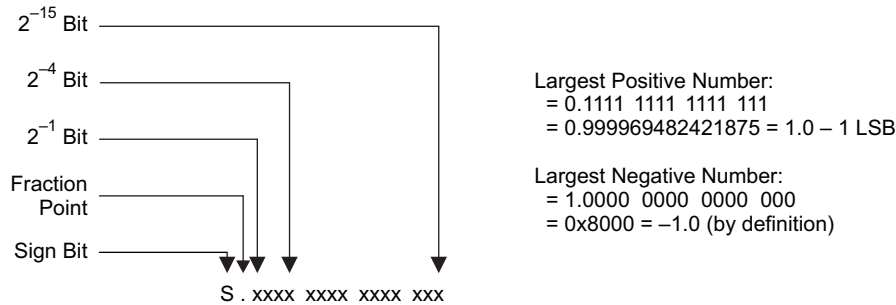

Figure 40. 2s-Complement Coefficient Format

10.3.12.3.1 First-Order IIR Section

The transfer function for the first-order IIR filter is given by Equation 3.

$$H(z) = \frac{N_0 + N_1z^{-1}}{2^{15} - D_1z^{-1}} \tag{3}$$

The frequency response for the first-order IIR section with default coefficients is flat at a gain of 0 dB.

Table 7. ADC First-Order IIR Filter Coefficients

FILTER	FILTER COEFFICIENT	ADC COEFFICIENT, LEFT CHANNEL	ADC COEFFICIENT, RIGHT CHANNEL
First-order IIR	N0	C4 (page 4 / register 8, 9)	C36 (page 4 / register 72, 73)
	N1	C5 (page 4 / register 10, 11)	C37 (page 4 / register 74, 75)
	D1	C6 (page 4 / register 12, 13)	C38 (page 4 / register 76, 77)

10.3.12.3.2 Biquad Section

The transfer function of each of the biquad filters is given by Equation 4.

$$H(z) = \frac{N_0 + 2 \times N_1z^{-1} + N_2z^{-2}}{2^{15} - 2 \times D_1z^{-1} - D_2z^{-2}} \tag{4}$$

The frequency response for each of the biquad sections with default coefficients is flat at a gain of 0 dB.

Table 8. ADC Biquad Filter Coefficients

FILTER	FILTER COEFFICIENT	ADC COEFFICIENT, LEFT CHANNEL	ADC COEFFICIENT, RIGHT CHANNEL
BIQUAD A	N0	C7 (page 4 / register 14, 15)	C39 (page 4 / register 78, 79)
	N1	C8 (page 4 / register 16, 17)	C40 (page 4 / register 80, 81)
	N2	C9 (page 4 / register 18, 19)	C41 (page 4 / register 82, 83)
	D1	C10 (page 4 / register 20, 21)	C42 (page 4 / register 84, 85)
	D2	C11 (page 4 / register 22, 23)	C43 (page 4 / register 86, 87)
BIQUAD B	N0	C12 (page 4 / register 24, 25)	C44 (page 4 / register 88, 89)
	N1	C13 (page 4 / register 26, 27)	C45 (page 4 / register 90, 91)
	N2	C14 (page 4 / register 28, 29)	C46 (page 4 / register 92, 93)
	D1	C15 (page 4 / register 30, 31)	C47 (page 4 / register 94, 95)
	D2	C16 (page 4 / register 32, 33)	C48 (page 4 / register 96, 97)

Table 8. ADC Biquad Filter Coefficients (continued)

FILTER	FILTER COEFFICIENT	ADC COEFFICIENT, LEFT CHANNEL	ADC COEFFICIENT, RIGHT CHANNEL
BIQUAD C	N0	C17 (page 4 / register 34, 35)	C49 (page 4 / register 98, 99)
	N1	C18 (page 4 / register 36, 37)	C50 (page 4 / register 100, 101)
	N2	C19 (page 4 / register 38, 39)	C51 (page 4 / register 102, 103)
	D1	C20 (page 4 / register 40, 41)	C52 (page 4 / register 104, 105)
	D2	C21 (page 4 / register 42, 43)	C53 (page 4 / register 106, 107)
BIQUAD D	N0	C22 (page 4 / register 44, 45)	C54 (page 4 / register 108, 109)
	N1	C23 (page 4 / register 46, 47)	C55 (page 4 / register 110, 111)
	N2	C24 (page 4 / register 48, 49)	C56 (page 4 / register 112,113)
	D1	C25 (page 4 / register 50, 51)	C57 (page 4 / register 114, 115)
	D2	C26 (page 4 / register 52, 53)	C58 (page 4 / register 116, 117)
BIQUAD E	N0	C27 (page 4 / register 54, 55)	C59 (page 4 / register 118, 119)
	N1	C28 (page 4 / register 56, 57)	C60 (page 4 / register 120, 121)
	N2	C29 (page 4 / register 58, 59)	C61 (page 4 / register 122,123)
	D1	C30 (page 4 / register 60, 61)	C62 (page 4 / register 124, 125)
	D2	C31 (page 4 / register 62, 63)	C63 (page 4 / register 126, 127)

10.3.12.3.3 FIR Section

Six of the available ADC processing blocks offer FIR filters for signal processing. PRB_R9 and PRB_R12 feature a 20-tap FIR filter, whereas the processing blocks PRB_R3, PRB_R6, PRB_R15, and PRB_R18 feature a 25-tap FIR filter.

$$H(z) = \sum_{n=0}^M \text{FIR}_n z^{-n}$$

M = 24 for PRB_R3, PRB_R6, PRB_R15, and PRB_R18

M = 19 for PRB_R9 and PRB_R12

(5)

The coefficients of the FIR filters are 16-bit 2s-complement format and correspond to the ADC coefficient space as listed in Table 9. There is no default transfer function for the FIR filter. When the FIR filter is used, all applicable coefficients must be programmed.

Table 9. ADC FIR Filter Coefficients

FILTER COEFFICIENT	ADC COEFFICIENT, LEFT CHANNEL	ADC COEFFICIENT, RIGHT CHANNEL
FIR0	C7 (page 4 / register 14, page 4 / register 15)	C39 (page 4 / register 78, page 4 / register 79)
FIR1	C8 (page 4 / register 16, page 4 / register 17)	C40 (page 4 / register 80, page 4 / register 81)
FIR2	C9 (page 4 / register 18, page 4 / register 19)	C41 (page 4 / register 82, page 4 / register 83)
FIR3	C10 (page 4 / register 20, page 4 / register 21)	C42 (page 4 / register 84, page 4 / register 85)
FIR4	C11 (page 4 / register 22, page 4 / register 23)	C43 (page 4 / register 86, page 4 / register 87)
FIR5	C12 (page 4 / register 24, page 4 / register 25)	C44 (page 4 / register 88, page 4 / register 89)
FIR6	C13 (page 4 / register 26, page 4 / register 27)	C45 (page 4 / register 90, page 4 / register 91)
FIR7	C14 (page 4 / register 28, page 4 / register 29)	C46 (page 4 / register 92, page 4 / register 93)
FIR8	C15 (page 4 / register 30, page 4 / register 31)	C47 (page 4 / register 94, page 4 / register 95)
FIR9	C16 (page 4 / register 32, page 4 / register 33)	C48 (page 4 / register 96, page 4 / register 97)
FIR10	C17 (page 4 / register 34, page 4 / register 35)	C49 (page 4 / register 98, page 4 / register 99)
FIR11	C18 (page 4 / register 36, page 4 / register 37)	C50 (page 4 / register 100, page 4 / register 101)
FIR12	C19 (page 4 / register 38, page 4 / register 39)	C51 (page 4 / register 102, page 4 / register 103)
FIR13	C20 (page 4 / register 40, page 4 / register 41)	C52 (page 4 / register 104, page 4 / register 105)
FIR14	C21 (page 4 / register 42, page 4 / register 43)	C53 (page 4 / register 106, page 4 / register 107)
FIR15	C22 (page 4 / register 44, page 4 / register 45)	C54 (page 4 / register 108, page 4 / register 109)
FIR16	C23 (page 4 / register 46, page 4 / register 47)	C55 (page 4 / register 110, page 4 / register 111)

Table 9. ADC FIR Filter Coefficients (continued)

FILTER COEFFICIENT	ADC COEFFICIENT, LEFT CHANNEL	ADC COEFFICIENT, RIGHT CHANNEL
FIR17	C24 (page 4 / register 48, page 4 / register 49)	C56 (page 4 / register 112, page 4 / register 113)
FIR18	C25 (page 4 / register 50, page 4 / register 51)	C57 (page 4 / register 114, page 4 / register 115)
FIR19	C26 (page 4 / register 52, page 4 / register 53)	C58 (page 4 / register 116, page 4 / register 117)
FIR20	C27 (page 4 / register 54, page 4 / register 55)	C59 (page 4 / register 118, page 4 / register 119)
FIR21	C28 (page 4 / register 56, page 4 / register 57)	C60 (page 4 / register 120, page 4 / register 121)
FIR22	C29 (page 4 / register 58, page 4 / register 59)	C61 (page 4 / register 122, page 4 / register 123)
FIR23	C30 (page 4 / register 60, page 4 / register 61)	C62 (page 4 / register 124, page 4 / register 125)
FIR24	C31 (page 4 / register 62, page 4 / register 63)	C63 (page 4 / register 126, page 4 / register 127)

10.3.12.4 Decimation Filter

The TLV320ADC3101 offers three different types of decimation filters. The integrated digital decimation filter removes high-frequency content and downsamples the audio data from an initial sampling rate of $AOSR \times f_s$ to the final output sampling rate of f_s . The decimation filtering is achieved using a higher-order CIC filter followed by linear-phase FIR filters. The decimation filter cannot be chosen by itself; it is implicitly set through the chosen processing block.

The following subsections describe the properties of the available filters A, B, and C.

10.3.12.4.1 Decimation Filter A

This filter is intended for use at sampling rates up to 48 kHz. When configuring this filter, the oversampling ratio of the ADC can either be 128 or 64. For highest performance, the oversampling ratio must be set to 128. Filter A can also be used for 96 kHz at an AOSR of 64.

Table 10. Specification for ADC Decimation Filter A

PARAMETER	CONDITION	VALUE (TYPICAL)	UNIT
AOSR = 128			
Filter gain pass band	0–0.39 f_S	0.062	dB
Filter gain stop band	0.55–64 f_S	–73	dB
Filter group delay		$17/f_S$	s
Pass-band ripple, 8 ksps	0–0.39 f_S	0.062	dB
Pass-band ripple, 44.18 ksps	0–0.39 f_S	0.05	dB
Pass-band ripple, 48 ksps	0–0.39 f_S	0.05	dB
AOSR = 64			
Filter gain pass band	0–0.39 f_S	0.062	dB
Filter gain stop band	0.55–32 f_S	–73	dB
Filter group delay		$17/f_S$	s
Pass-band ripple, 8 ksps	0–0.39 f_S	0.062	dB
Pass-band ripple, 44.18 ksps	0–0.39 f_S	0.05	dB
Pass-band ripple, 48 ksps	0–0.39 f_S	0.05	dB
Pass-band ripple, 96 ksps	0–20 kHz	0.1	dB

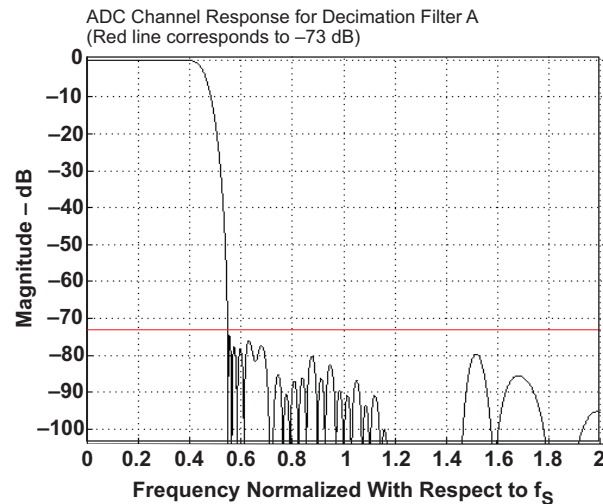
Figure 41. ADC Decimation Filter A, Frequency Response

10.3.12.4.2 Decimation Filter B

Filter B is intended to support sampling rates up to 96 kHz at an oversampling ratio of 64.

Table 11. Specification for ADC Decimation Filter B

PARAMETER	CONDITION	VALUE (TYPICAL)	UNIT
AOSR = 64			
Filter gain pass band	0–0.39 f_S	± 0.077	dB
Filter gain stop band	0.6 f_S –32 f_S	–46	dB
Filter group delay		$11/f_S$	s
Pass-band ripple, 8 ksps	0–0.39 f_S	0.076	dB
Pass-band ripple, 44.18 ksps	0–0.39 f_S	0.06	dB
Pass-band ripple, 48 ksps	0–0.39 f_S	0.06	dB
Pass-band ripple, 96 ksps	0–20 kHz	0.11	dB

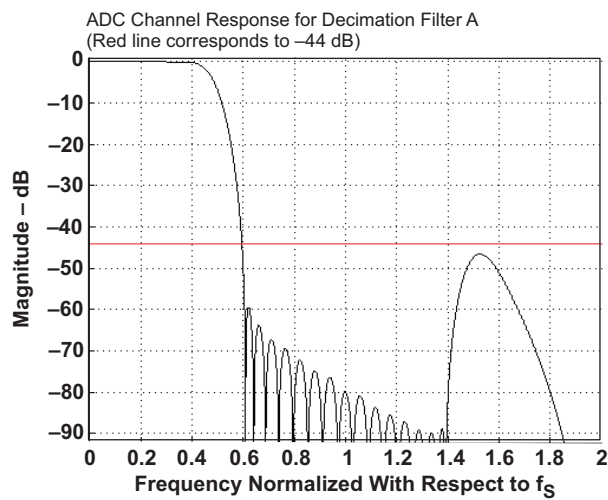

Figure 42. ADC Decimation Filter B, Frequency Response

10.3.12.4.3 Decimation Filter C

Filter type C along with an AOSR of 32 is specially designed for 192-kSPS operation of the ADC. The pass band, which extends up to $0.11 \times f_S$ (corresponds to 21 kHz), is suited for audio applications.

Table 12. Specifications for ADC Decimation Filter C

PARAMETER	CONDITION	VALUE (TYPICAL)	UNIT
Filter gain from 0 to $0.11 f_S$	$0-0.11 f_S$	± 0.033	dB
Filter gain from $0.28 f_S$ to $16 f_S$	$0.28 f-16 f_S$	-60	dB
Filter group delay		$11/f_S$	s
Pass-band ripple, 8 kSPS	$0-0.11 f_S$	0.033	dB
Pass-band ripple, 44.18 kSPS	$0-0.11 f_S$	0.033	dB
Pass-band ripple, 48 kSPS	$0-0.11 f_S$	0.032	dB
Pass-band ripple, 96 kSPS	$0-0.11 f_S$	0.032	dB
Pass-band ripple, 192 kSPS	0–20 kHz	0.086	dB

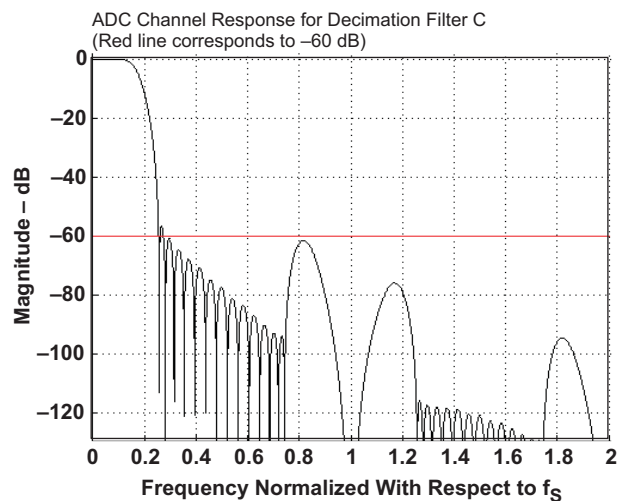

Figure 43. ADC Decimation Filter C, Frequency Response

10.3.12.5 ADC Data Interface

The decimation filter and signal processing block in the ADC channel passes 32-bit data words to the audio serial interface once every frame (WCLK). During each frame (WCLK), a pair of data words (for left and right channels) is passed. The audio serial interface rounds the data to the required word length of the interface before converting to serial data per the different modes for audio serial interface.

10.3.12.6 Digital Microphone Function

In addition to supporting analog microphones, the TLV320ADC3101 also interfaces to digital microphones.

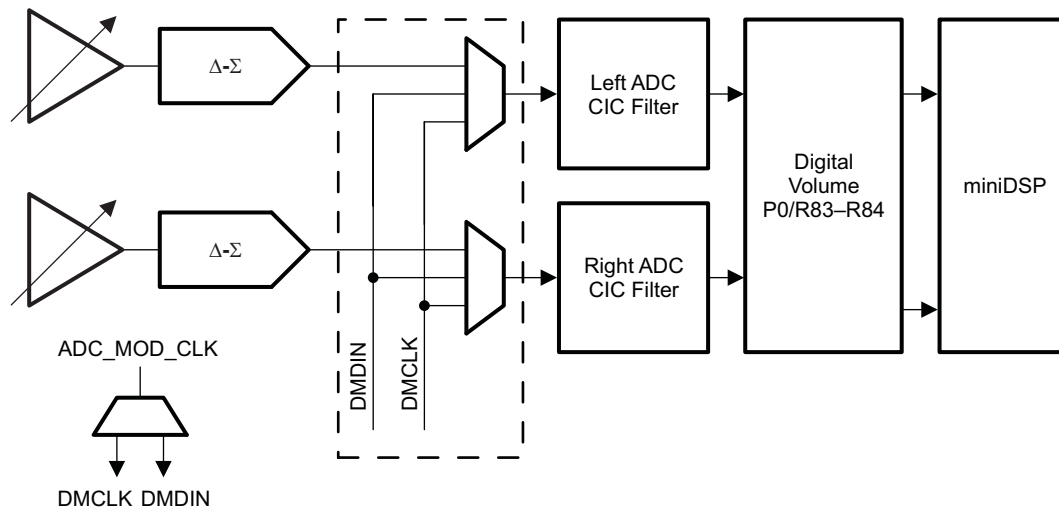

Figure 44. Digital Microphone in TLV320ADC3101

The TLV320ADC3101 outputs internal clock ADC_MOD_CLK on the DMCLK pin (page 0 / register 51, bits D5–D2) or DMDIN pin (page 0 / register 52, bits D5–D2). This clock can be connected to the external digital microphone device. The single-bit output of the external digital microphone device can be connected to DMDIN or DMCLK pins. Internally, the TLV320ADC3101 latches the steady value of data on a selectable edge (page 0 / register 80, bit D1) of ADC_MOD_CLK for the left ADC channel, and the steady value of data on a selectable edge (page 0 / register 80, bit D0) for the right ADC channel.

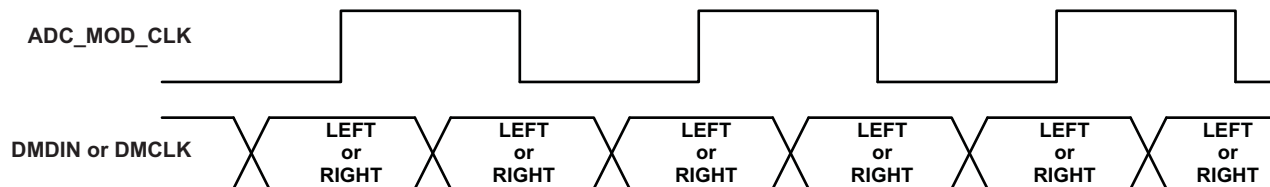

Figure 45. Timing Diagram for Digital Microphone Interface

The digital-microphone mode can be selectively enabled for only-left, only-right, or stereo channels. When the digital microphone mode is enabled, the analog section of the ADC can be powered down and bypassed for power efficiency. The AOSR value for the ADC channel must be configured to select the desired decimation ratio to be achieved based on the external digital microphone properties. Following the CIC filter is a stereo digital volume control, where left and right volume are adjusted by writing to page 0 / register 83 and page 0 / register 84, respectively. Next is the miniDSP, where the processing blocks can be selected or custom processing can be used. The processed digital microphone signal is then output at the DOUT pin.

10.4 Device Functional Modes

10.4.1 Recording Mode

The recording mode is activated once the ADC blocks are enabled. The record path operates from 8 kHz to 48 kHz in single-rate mode and up to 96 kHz in dual-rate mode. It contains programmable input channel configurations supporting single-ended and differential setups. In order to provide optimal system power management, the stereo recording path can be powered up one channel at time, to support the case where only mono record capability is required. Digital signal processing blocks can remove audible noise that may be introduced by mechanical coupling. The TLV320ADC3101 includes Automatic Gain Control (AGC) and a Digital Microphone Interface for ADC recording.

10.5 Programming

10.5.1 Digital Control Serial Interface

10.5.1.1 I²C Control Mode

The TLV320ADC3101 supports the I²C control protocol and is capable of both standard and fast modes. Standard mode is up to 100 kHz and fast mode is up to 400 kHz. When in I²C control mode, the TLV320ADC3101 can be configured for one of four different addresses, using the pins I2C_ADR1 and I2C_ADR0, which control the two LSBs of the device address. The 5 MSBs of the device address are fixed as 0011 0 and cannot be changed, while the two LSBs are given by I2C_ADR1:I2C_ADR0. This results in four possible device addresses:

Table 13. I²C Slave Device Addresses for I2C_ADR1, I2C_ADR0 Settings

I2C_ADR1	I2C_ADR0	DEVICE ADDRESS
0	0	0011 000
0	1	0011 001
1	0	0011 010
1	1	0011 011

I²C is a two-wire, open-drain interface supporting multiple devices and masters on a single bus. Devices on the I²C bus only drive the bus lines LOW by connecting them to ground; they never drive the bus lines HIGH. Instead, the bus wires are pulled HIGH by pullup resistors, so the bus wires are HIGH when no device is driving them LOW. This way, two devices cannot conflict; if two devices drive the bus simultaneously, there is no driver contention.

Communication on the I²C bus always takes place between two devices, one acting as the master and the other acting as the slave. Both masters and slaves can read and write, but slaves can only do so under the direction of the master. Some I²C devices can act as masters or slaves, but the TLV320ADC3101 can only act as a slave device.

An I²C bus consists of two lines, SDA and SCL. SDA carries data; SCL provides the clock. All data is transmitted across the I²C bus in groups of eight bits. To send a bit on the I²C bus, the SDA line is driven to the appropriate level while SCL is LOW (a LOW on SDA indicates the bit is 0; a HIGH indicates the bit is 1). Once the SDA line has settled, the SCL line is brought HIGH, then LOW. This pulse on SCL clocks the SDA bit into the receiver shift register.

The I²C bus is bidirectional: the SDA line is used both for transmitting and receiving data. When a master reads from a slave, the slave drives the data line; when a master sends to a slave, the master drives the data line. Under normal circumstances, the master drives the clock line.

Most of the time the bus is idle, no communication is taking place, and both lines are HIGH. When communication is taking place, the bus is active. Only master devices can start a communication. They do this by causing a START condition on the bus. Normally, the data line is only allowed to change state while the clock line is LOW. If the data line changes state while the clock line is HIGH, it is either a START condition or its counterpart, a STOP condition. A START condition is when the clock line is HIGH and the data line goes from HIGH to LOW. A STOP condition is when the clock line is HIGH and the data line goes from LOW to HIGH.

After the master issues a START condition, it sends a byte that indicates the slave device with which it is to communicate. This byte is called the address byte. Each device on an I²C bus has a unique 7-bit address to which it responds. (Slaves can also have 10-bit addresses; see the I²C specification for details.) The master sends an address in the address byte, together with a bit that indicates whether it is to read from or write to the slave device.

Every byte transmitted on the I²C bus, whether it is address or data, is acknowledged with an acknowledge bit. When a master has finished sending a byte (eight data bits) to a slave, it stops driving SDA and waits for the slave to acknowledge the byte. The slave acknowledges the byte by pulling SDA LOW. The master then sends a clock pulse to clock the acknowledge bit. Similarly, when a master has finished reading a byte, it pulls SDA LOW to acknowledge this to the slave. It then sends a clock pulse to clock the bit.

A not-acknowledge is performed by leaving SDA HIGH during an acknowledge cycle. If a device is not present on the bus, and the master attempts to address it, it receives a not-acknowledge because no device is present at that address to pull the line LOW.

When a master has finished communicating with a slave, it may issue a STOP condition. When a STOP condition is issued, the bus becomes idle again. A master may also issue another START condition. When a START condition is issued while the bus is active, it is called a repeated START condition.

The TLV320ADC3101 also responds to and acknowledges a general call, which consists of the master issuing a command with a slave address byte of 00h.

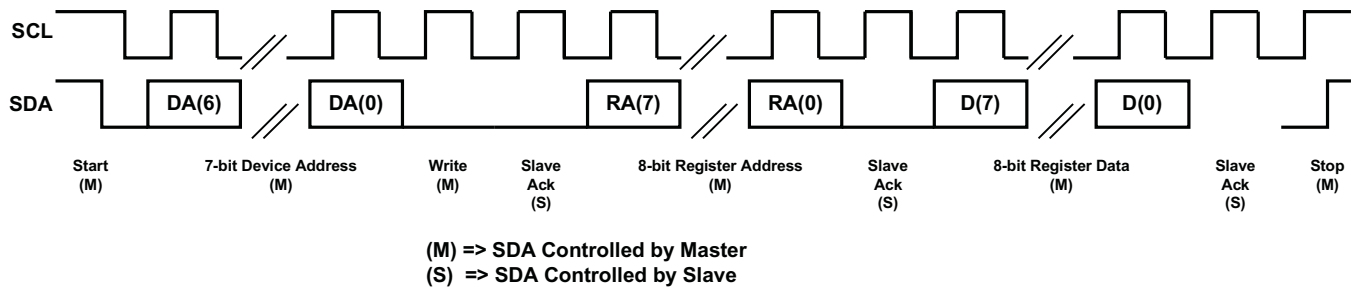

Figure 46. I²C Write

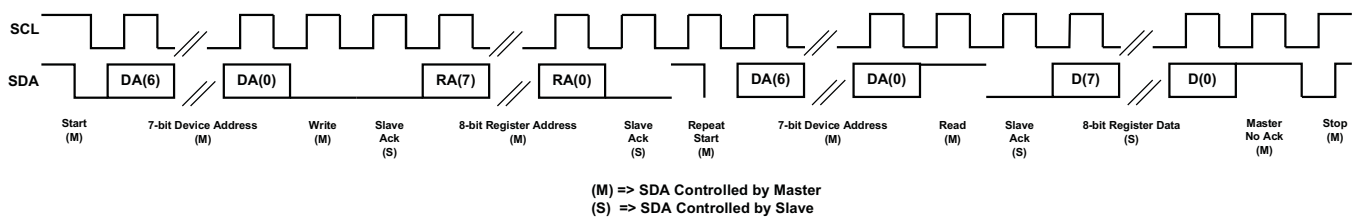

Figure 47. I²C Read

In the case of an I²C register write, if the master does not issue a STOP condition, then the device enters auto-increment mode. So in the next eight clocks, the data on SDA is treated as data for the next incremental register.

Similarly, in the case of an I²C register read, after the device has sent out the 8-bit data from the addressed register, if the master issues an ACKNOWLEDGE, the slave takes over control of SDA bus and transmits for the next eight clocks the data of the next incremental register.

10.6 Register Maps

10.6.1 Control Registers

The control registers for the TLV320ADC3101 are described in detail as follows. All registers are 8 bits in width, with D7 referring to the most-significant bit of each register and D0 referring to the least-significant bit.

Pages 0, 1, 4, 5, and 32–47 are available. All other pages are reserved. Do not read from or write to reserved pages.

The procedure for register access is:

- Select page N (Write data N to register 0 regardless of the current page number).
- Read or write data from/to valid registers in page N.
- Select new page M (Write data M to register 0 regardless of the current page number).
- Read or write data from/to valid registers in page M.
- Repeat as desired

Register Maps (continued)
Table 14. Page / Register Map

REGISTER NO.	REGISTER NAME
PAGE 0: (Clock Multipliers and Dividers, Serial Interfaces, Flags, Interrupts and Programming of GPIOs)	
0	Page control register
1	S/W RESET
2	Reserved
3	Reserved
4	Clock-gen multiplexing
5	PLL P and R-VAL
6	PLL J-VAL
7	PLL D-VAL MSB
8	PLL D-VAL LSB
9–17	Reserved
18	ADC NADC
19	ADC MADC
20	ADC AOSR
21	ADC IADC
22	ADC miniDSP engine decimation
23–24	Reserved
25	CLKOUT MUX
26	CLKOUT M Divider
27	ADC audio interface control 1
28	Data slot offset programmability 1 (Ch_Offset_1)
29	ADC interface control 2
30	BCLK N Divider
31	Secondary audio interface control 1
32	Secondary audio interface control 2
33	Secondary audio interface control 3
34	I ² S sync
35	Reserved
36	ADC flag register
37	Data slot offset programmability 2 (Ch_Offset_2)
38	I ² S TDM control register
39–41	Reserved
42	Interrupt flags (overflow)
43	Interrupt flags (overflow)
44	Reserved
45	Interrupt flags–ADC
46	Reserved
47	Interrupt flags–ADC
48	INT1 interrupt control
49	INT2 interrupt control
50	Reserved
51	DMCLK/GPIO2 control
52	DMDIN/GPIO1 control
53	DOUT (out pin) control
54–56	Reserved
57	ADC sync control 1

Register Maps (continued)
Table 14. Page / Register Map (continued)

REGISTER NO.	REGISTER NAME
58	ADC sync control 2
59	ADC CIC filter gain control
60	Reserved
61	ADC processing block selection
62	Programmable instruction mode control bits
63–79	Reserved
80	Digital microphone polarity control
81	ADC digital
82	ADC fine volume control
83	Left ADC volume control
84	Right ADC volume control
85	ADC phase compensation
86	Left AGC control 1
87	Left AGC control 2
88	Left AGC maximum gain
89	Left AGC attack time
90	Left AGC decay time
91	Left AGC noise debounce
92	Left AGC signal debounce
93	Left AGC gain
94	Right AGC control 1
95	Right AGC control 2
96	Right AGC maximum gain
97	Right AGC attack time
98	Right AGC decay time
99	Right AGC noise debounce
100	Right AGC signal debounce
101	Right AGC gain
102–127	Reserved
PAGE1: (ADC Routing, PGA, Power-Controls, and so forth)	
0	Page control register
1–25	Reserved
26	Dither control
27–50	Reserved
51	MICBIAS control
52	Left ADC input selection for left PGA
53	Reserved
54	Left ADC input selection for left PGA
55	Right ADC input selection for right PGA
56	Reserved
57	Right ADC input selection for right PGA
58	Reserved
59	Left analog PGA setting
60	Right analog PGA setting
61	ADC low-current modes
62	ADC analog PGA flags
63–127	Reserved

Register Maps (continued)
Table 14. Page / Register Map (continued)

REGISTER NO.	REGISTER NAME
	PAGE 2: Reserved. Do not read or write to this page.
	PAGE 3: Reserved. Do not read or write to this page.
	PAGE 4: ADC Programmable Coefficients RAM (1:63)
	PAGE 5: ADC Programmable Coefficients RAM (65:127)
	PAGES 6–31: Reserved. Do not read from or write to these pages.
	PAGES 32-47: ADC DSP Instruction RAM (Inst_0–Inst_511)
	Page 32 Instructions Inst_0–Inst_31
	Page 33 Instructions Inst_32–Inst_63
	Page 34 Instruction Inst_64–Inst_95
	...
	Page 47 Instruction Inst_480–Inst_511
	PAGES 48–255: Reserved. Do not read from or write to these pages.

10.6.2 Control Registers, Page 0: Clock Multipliers and Dividers, Serial Interfaces, Flags, Interrupts and Programming of GPIOs
Table 15. Page 0 / Register 0: Page Control Register⁽¹⁾

BIT	READ/ WRITE	RESET VALUE	DESCRIPTION
D7–D0	R/W	0000 0000	0000 0000: Page 0 selected 0000 0001: Page 1 selected ... 1111 1110: Page 254 selected (reserved) 1111 1111: Page 255 selected (reserved)

(1) Valid pages are 0, 1, 4, 5, 32-47. All other pages are reserved (do not access).

Table 16. Page 0 / Register 1: Software Reset

BIT	READ/ WRITE	RESET VALUE	DESCRIPTION
D7–D1	R	0000 000	Reserved. Write only zeros to these bits.
D0	W	0	0: Don't care 1: Self-clearing software reset for control register

Table 17. Page 0 / Register 2: Reserved

BIT	READ/ WRITE	RESET VALUE	DESCRIPTION
D7–D0	R	0000 0000	Reserved. Do not write any value other than reset value.

Table 18. Page 0 / Register 3: Reserved

BIT	READ/ WRITE	RESET VALUE	DESCRIPTION
D7–D0	R	XXXX XXXX	Reserved. Do not write to this register.

Table 19. Page 0 / Register 4: Clock-Gen Multiplexing⁽¹⁾

BIT	READ/ WRITE	RESET VALUE	DESCRIPTION
D7–D4	R	0000	Reserved. Do not write any value other than reset value.
D3–D2	R/W	00	00: PLL_CLKIN = MCLK (device pin) 01: PLL_CLKIN = BCLK (device pin) 10: Reserved. Do not use. 11: PLL_CLKIN = logic level 0
D1–D0	R/W	00	00: CODEC_CLKIN = MCLK (device pin) 01: CODEC_CLKIN = BCLK (device pin) 10: Reserved. Do not use. 11: CODEC_CLKIN = PLL_CLK (generated on-chip)

(1) Refer to [Figure 28](#) for more details on clock generation multiplexing and dividers.

Table 20. Page 0 / Register 5: PLL P and R-VAL

BIT	READ/ WRITE	RESET VALUE	DESCRIPTION
D7	R/W	0	0: PLL is powered down. 1: PLL is powered up.
D6–D4	R/W	001	000: PLL divider P = 8 001: PLL divider P = 1 010: PLL divider P = 2 ... 110: PLL divider P = 6 111: PLL divider P = 7
D3–D0	R/W	0001	0000: PLL multiplier R = 16 0001: PLL multiplier R = 1 0010: PLL multiplier R = 2 ... 1110: PLL multiplier R = 14 1111: PLL multiplier R = 15

Table 21. Page 0 / Register 6: PLL J-VAL

BIT	READ/ WRITE	RESET VALUE	DESCRIPTION
D7–D6	R/W	00	Reserved. Write only zeros to these bits.
D5–D0	R/W	00 0100	00 0000: Don't use (reserved) 00 0001: PLL multiplier J = 1 00 0010: PLL multiplier J = 2 00 0011: PLL multiplier J = 3 00 0100: PLL multiplier J = 4 (Default) ... 11 1110: PLL multiplier J = 62 11 1111: PLL multiplier J = 63

Table 22. Page 0 / Register 7: PLL D-VAL MSB⁽¹⁾

BIT	READ/ WRITE	RESET VALUE	DESCRIPTION
D7–D6	R/W	00	Reserved. Write only zeros to these bits.
D5–D0	R/W	00 0000	PLL fractional multiplier D13–D8

(1) Page 0 / Register 7 will be updated when Page 0 / Register 8 is written immediately after Page 0 / Register 7 is written.

Table 23. Page 0 / Register 8: PLL D-VAL LSB⁽¹⁾

BIT	READ/ WRITE	RESET VALUE	DESCRIPTION
D7–D0	R/W	0000 0000	PLL fractional multiplier D7–D0

(1) Page 0 / Register 8 must be written immediately after writing to Page 0 / Register 7.

Table 24. Page 0 / Register 9 Through Page 0 / Register 17: Reserved

BIT	READ/ WRITE	RESET VALUE	DESCRIPTION
D7–D0	R	XXXX XXXX	Reserved. Do not write to these registers.

Table 25. Page 0 / Register 18: ADC NADC Clock Divider

BIT	READ/ WRITE	RESET VALUE	DESCRIPTION
D7	R/W	0	NADC Clock Divider Power Control: 0: NADC clock divider is powered down 1: NADC clock divider is powered up
D6–D0	R/W	000 0001	NADC Value: 000 0000: NADC clock divider = 128 000 0001: NADC clock divider = 1 000 0010: NADC clock divider = 2 ... 111 1110: NADC clock divider = 126 111 1111: NADC clock divider = 127

Table 26. Page 0 / Register 19: ADC MADC Clock Divider

BIT	READ/ WRITE	RESET VALUE	DESCRIPTION
D7	R/W	0	0: ADC MADC clock divider is powered down 1: ADC MADC clock divider is powered up
D6–D0	R/W	000 0001	000 0000: MADC clock divider = 128 000 0001: MADC clock divider = 1 000 0010: MADC clock divider = 2 ... 111 1110: MADC clock divider = 126 111 1111: MADC clock divider = 127

Table 27. Page 0 / Register 20: ADC AOSR⁽¹⁾

BIT	READ/ WRITE	RESET VALUE	DESCRIPTION
D7–D0	R/W	1000 0000	ADC Oversampling Value (AOSR): 0000 0000: AOSR = 256 0000 0001: AOSR = 1 0000 0010: AOSR = 2 ... 1111 1110: AOSR = 254 1111 1111: AOSR = 255

(1) AOSR must be an integral multiple of the ADC decimation factor.

Table 28. Page 0 / Register 21: ADC IADC⁽¹⁾

BIT	READ/ WRITE	RESET VALUE	DESCRIPTION
D7–D0	R/W	1000 0000	0000 0000: Reserved. Do not use. Number of instructions for ADC miniDSP (IADC): 0000 0001: IADC = 2 0000 0010: IADC = 4 ... 1011 1111: IADC = 382 1100 0000: IADC = 384 1100 0001–1111 1111: IADC = up to 510

(1) IADC must be an integral multiple of the ADC decimation factor.

Table 29. Page 0 / Register 22: ADC miniDSP Engine Decimation

BIT	READ/ WRITE	RESET VALUE	DESCRIPTION
D7–D4	R	0000	Reserved. Do not write any value other than reset value.
D3–D0	R/W	0100	0000: Decimation ratio in ADC miniDSP engine = 16 0001: Decimation ratio in ADC miniDSP engine = 1 0010: Decimation ratio in ADC miniDSP engine = 2 ... 1101: Decimation ratio in ADC miniDSP engine = 13 1110: Decimation ratio in ADC miniDSP engine = 14 1111: Decimation ratio in ADC miniDSP engine = 15

Table 30. Page 0 / Register 23 Through Page 0 / Register 24: Reserved

BIT	READ/ WRITE	RESET VALUE	DESCRIPTION
D7–D0	R	XXXX XXXX	Reserved. Do not write to these registers.

Table 31. Page 0 / Register 25: CLKOUT MUX

BIT	READ/ WRITE	RESET VALUE	DESCRIPTION
D7–D3	R	0000 0	Reserved. Do not write any value other than reset value.
D2–D0	R/W	000	000: CDIV_CLKIN = MCLK (device pin) 001: CDIV_CLKIN = BCLK (device pin) 010: Reserved. Do not use. 011: CDIV_CLKIN = PLL_CLK (generated on-chip) 100: Reserved. Do not use. 101: Reserved. Do not use. 110: CDIV_CLKIN = ADC_CLK (generated on-chip) 111: CDIV_CLKIN = ADC_MOD_CLK (generated on-chip)

Table 32. Page 0 / Register 26: CLKOUT M Divider

BIT	READ/ WRITE	RESET VALUE	DESCRIPTION
D7	R/W	0	0: CLKOUT M divider is powered down. 1: CLKOUT M divider is powered up.
D6–D0	R/W	000 0001	000 0000: CLKOUT divider M = 128 000 0001: CLKOUT divider M = 1 000 0010: CLKOUT divider M = 2 ... 111 1110: CLKOUT divider M = 126 111 1111: CLKOUT divider M = 127

Table 33. Page 0 / Register 27: ADC Audio Interface Control 1

BIT	READ/ WRITE	RESET VALUE	DESCRIPTION
D7–D6	R/W	00	00: ADC interface = I ² S 01: ADC interface = DSP 10: ADC interface = RJF 11: ADC interface = LJF
D5–D4	R/W	00	00: ADC interface word length = 16 bits 01: ADC interface word length = 20 bits 10: ADC interface word length = 24 bits 11: ADC interface word length = 32 bits
D3	R/W	0	0: BCLK is input. 1: BCLK is output.
D2	R/W	0	0: WCLK is input. 1: WCLK is output.
D1	R	0	Reserved. Do not write any value other than reset value.
D0	R/W	0	0: 3-stating of DOUT: disabled 1: 3-stating of DOUT: enabled

Table 34. Page 0 / Register 28: Data Slot Offset Programmability 1 (Ch_Offset_1)

BIT	READ/ WRITE	RESET VALUE	DESCRIPTION
D7–D0	R/W	0000 0000	0000 0000: Offset = 0 BCLKs. Offset is measured with respect to WCLK rising edge in DSP mode. ⁽¹⁾ 0000 0001: Offset = 1 BCLKs 0000 0010: Offset = 2 BCLKs ... 1111 1110: Offset = 254 BCLKs 1111 1111: Offset = 255 BCLKs

(1) Usage controlled by page 0 / register 38, bit D0

Table 35. Page 0 / Register 29: ADC Interface Control 2

BIT	READ/ WRITE	RESET VALUE	DESCRIPTION
D7–D4	R/W	0000	Reserved. Do not write any value other than reset value.
D3	R/W	0	0: BCLK is not inverted (valid for both primary and secondary BCLK). 1: BCLK is inverted (valid for both primary and secondary BCLK).
D2	R/W	0	0: BCLK and WCLK active even with codec powered down: disabled (valid for both primary and secondary BCLK) 1: BCLK and WCLK active even with codec powered down: enabled (valid for both primary and secondary BCLK)
D1–D0	R/W	10	00: Reserved. Do not use. 01: Reserved. Do not use. 10: BDIV_CLKIN = ADC_CLK (generated on-chip) 11: BDIV_CLKIN = ADC_MOD_CLK (generated on-chip)

Table 36. Page 0 / Register 30: BCLK N Divider

BIT	READ/ WRITE	RESET VALUE	DESCRIPTION
D7	R/W	0	0: BCLK N divider is powered down. 1: BCLK N divider is powered up.
D6–D0	R/W	000 0001	000 0000: CLKOUT divider N = 128 000 0001: CLKOUT divider N = 1 000 0010: CLKOUT divider N = 2 ... 111 1110: CLKOUT divider N = 126 111 1111: CLKOUT divider N = 127

Table 37. Page 0 / Register 31: Secondary Audio Interface Control 1

BIT	READ/ WRITE	RESET VALUE	DESCRIPTION
D7	R	0	Reserved. Do not write any value other than reset value.
D6–D5	R/W	00	00: Secondary BCLK is obtained from GPIO1 pin. 01: Secondary BCLK is obtained from GPIO2 pin. 10 – 11: Reserved. Do not use.
D4–D3	R/W	00	00: Secondary WCLK is obtained from GPIO1 pin. 01: Secondary WCLK is obtained from GPIO2 pin. 10 – 11: Reserved. Do not use.
D2–D1	R/W	00	Reserved. Do not use.
D0	R	0	Reserved. Do not write any value other than reset value.

Table 38. Page 0 / Register 32: Secondary Audio Interface Control 2

BIT	READ/ WRITE	RESET VALUE	DESCRIPTION
D7–D4	R	0000	Reserved. Do not write any value other than reset value.
D3	R/W	0	0: Primary BCLK is used for audio interface and clocking. 1: Secondary BCLK is used for audio interface and clocking.
D2	R/W	0	0: Primary WCLK is used for audio interface and clocking. 1: Secondary WCLK is used for audio interface and clocking.
D1–D0	R	00	Reserved. Do not write any value other than reset value.

Table 39. Page 0 / Register 33: Secondary Audio Interface Control 3

BIT	READ/ WRITE	RESET VALUE	DESCRIPTION
D7	R/W	0	0: Primary BCLK output = internally generated BCLK clock 1: Primary BCLK output = secondary BCLK
D6	R/W	0	0: Secondary BCLK output = primary BCLK 1: Secondary BCLK output = internally generated BCLK clock
D5–D4	R/W	01	00: Reserved. Do not use. 01: Primary WCLK output = internally generated ADC _{fs} clock (Default) 10: Primary WCLK output = secondary WCLK 11: Reserved. Do not use.
D3–D2	R/W	00	00: Secondary WCLK output = primary WCLK 01: Reserved. Do not use. 10: Secondary WCLK output = internally generated ADC _{fs} clock 11: Reserved. Do not use.
D1–D0	R	00	Reserved. Do not write any value other than reset value.

Table 40. Page 0 / Register 34: I²S Sync

BIT	READ/ WRITE	RESET VALUE	DESCRIPTION
D7	R/W	0	0: Internal logic is enabled to detect the I ² C hang and react accordingly. 1: Internal logic is disabled to detect the I ² C hang.
D6 ⁽¹⁾	R/W	0	0: I ² C hang is not detected. 1: I ² C hang detected flag. Once set get cleared only after reading this register.
D5	R/W	0	0: I ² C general-call address is ignored. 1: Device accepts I ² C general-call address.
D4–D2	R	000	Reserved. Do not write any value other than reset value.
D1	R/W	0	0: Re-sync logic is disabled for ADC. 1: Re-sync stereo ADC with codec interface if the group delay changed by more than $\pm\text{ADC}_{fs}/4$.
D0	R/W	0	0: Re-sync is done without soft-muting the channel for ADC. 1: Re-sync is done by internally soft-muting the channel for ADC.

(1) Read-only bits. Writing any value to this is not used anywhere.

Table 41. Page 0 / Register 35: Reserved

BIT	READ/ WRITE	RESET VALUE	DESCRIPTION
D7–D0	R	XXXX XXXX	Reserved. Do not write to this register.

Table 42. Page 0 / Register 36: ADC Flag Register

BIT	READ/ WRITE	RESET VALUE	DESCRIPTION
D7 ⁽¹⁾	R	0	0: Left ADC PGA , applied gain ≠ programmed gain 1: Left ADC PGA , applied gain = programmed gain
D6 ⁽¹⁾	R	0	0: Left ADC powered down 1: Left ADC powered up
D5 ⁽²⁾	R	0	0: Left AGC not saturated 1: Left AGC applied gain = maximum applicable gain by left AGC
D4	R	0	Reserved. Do not write any value other than reset value.
D3 ⁽¹⁾	R	0	0: Right ADC PGA , applied gain ≠ programmed gain 1: Right ADC PGA , applied gain = programmed gain
D2 ⁽¹⁾	R	0	0: Right ADC powered down 1: Right ADC powered up
D1 ⁽²⁾	R	0	0: Right AGC not saturated 1: Right AGC applied gain = maximum applicable gain by right AGC
D0	R	0	Reserved. Do not write any value other than reset value.

- (1) Read-only bits. Writing any value to this bit is not used anywhere.
 (2) Sticky flag bits. These are read-only bits. They are automatically cleared once they are read and are set only if the source trigger occurs freshly again.

Table 43. Page 0 / Register 37: Data Slot Offset Programmability 2 (Ch_Offset_2)

BIT	READ/ WRITE	RESET VALUE	DESCRIPTION
D7–D0	R/W	0000 0000	0000 0000: Offset = 0 BCLKs. Offset is measured with respect to the end of the first channel ⁽¹⁾ 0000 0001: Offset = 1 BCLKs 0000 0010: Offset = 2 BCLKs ... 1111 1110: Offset = 254 BCLKs 1111 1111: Offset = 255 BCLKs

- (1) Usage controlled by page 0 / register 38, bit D0, time_slot_mode_enable

Table 44. Page 0 / Register 38: I²S TDM Control Register

BIT	READ/ WRITE	RESET VALUE	DESCRIPTION
D7–D5	R	000	Reserved. Do not write any value other than reset value.
D4	R/W	0	0: Channel swap disabled 1: Channel swap enabled
D3–D2	R/W	00	00: Both left and right channels enabled 01: Left channel enabled 10: Right channel enabled 11: Both left and right channels disabled
D1	R/W	1	0: early_3-state disabled 1: early_3-state enabled
D0	R/W	0	0: time_slot_mode disabled – both channel offsets controlled by Ch_Offset_1 (page 0 / register 28) 1: time_slot_mode enabled – channel-1 offset controlled by Ch_Offset_1 (page 0 / register 28) and channel-2 offset controlled by Ch_Offset_2 (page 0 / register 37)

Table 45. Page 0 / Register 39 Through Page 0 / Register 41: Reserved

BIT	READ/ WRITE	RESET VALUE	DESCRIPTION
D7–D0	R	XXXX XXXX	Reserved. Do not write to these registers.

Table 46. Page 0 / Register 42: Interrupt Flags (Overflow)

BIT	READ/ WRITE	RESET VALUE	DESCRIPTION
D7–D4	R	0000	Reserved
D3 ⁽¹⁾	R	0	Left ADC overflow flag
D2 ⁽¹⁾	R	0	Right ADC overflow flag
D1 ⁽¹⁾	R	0	ADC barrel-shifter output-overflow flag
D0	R	0	Reserved

(1) Sticky flag bits. These are read-only bits. They are automatically cleared once they are read and are set only if the source trigger occurs freshly again.

Table 47. Page 0 / Register 43: Interrupt Flags (Overflow)

BIT	READ/ WRITE	RESET VALUE	DESCRIPTION
D7–D4	R	0000	Reserved
D3	R	0	Left ADC overflow flag
D2	R	0	Right ADC overflow flag
D1	R	0	ADC barrel-shifter output-overflow flag
D0	R	0	Reserved

Table 48. Page 0 / Register 44: Reserved

BIT	READ/ WRITE	RESET VALUE	DESCRIPTION
D7–D0	R	XXXX XXXX	Reserved. Do not write to this register.

Table 49. Page 0 / Register 45: Interrupt Flags—ADC

BIT	READ/ WRITE	RESET VALUE	DESCRIPTION ⁽¹⁾
D7	R	0	Reserved
D6	R	0	Left AGC Noise Threshold Flag: 0: Left ADC signal power greater than noise threshold for left AGC 1: Left ADC signal power lesser than noise threshold for left AGC
D5	R	0	Right AGC Noise Threshold Flag: 0: Right ADC signal power greater than noise threshold for right AGC 1: Right ADC signal power lesser than noise threshold for right AGC
D4	R	0	ADC miniDSP engine standard interrupt-port output
D3	R	0	ADC miniDSP engine auxilliary interrupt-port output
D2–D0	R	000	Reserved

(1) Sticky flag bits. These are read-only bits. They are automatically cleared once they are read and are set only if the source trigger occurs freshly again.

Table 50. Page 0 / Register 46: Reserved

BIT	READ/ WRITE	RESET VALUE	DESCRIPTION
D7–D0	R	XXXX XXXX	Reserved. Do not write to this register.

Table 51. Page 0 / Register 47: Interrupt Flags—ADC

BIT	READ/ WRITE	RESET VALUE	DESCRIPTION
D7	R	0	Reserved
D6	R	0	0: Left ADC signal power greater than noise threshold for left AGC 1: Left ADC signal power less than noise threshold for left AGC
D5	R	0	0: Right ADC signal power greater than noise threshold for right AGC 1: Right ADC signal power less than noise threshold for right AGC
D4	R	0	ADC miniDSP engine standard interrupt-port output. This bit indicates the instantaneous value of the interrupt port at the time of reading the register.
D3	R	0	ADC miniDSP engine auxiliary interrupt-port output. This bit indicates the instantaneous value of the interrupt port at the time of reading the register.
D2–D0	R	000	Reserved

Table 52. Page 0 / Register 48: INT1 Interrupt Control

BIT	READ/ WRITE	RESET VALUE	DESCRIPTION
D7–D5	R	000	Reserved. Do not write any value other than reset value.
D4	R/W	0	0: ADC AGC noise interrupt is not used in the generation of INT1 interrupt. 1: ADC AGC noise interrupt is used in the generation of INT1 interrupt.
D3	R	0	Reserved. Do not write any value other than reset value.
D2	R/W	0	0: Engine-generated interrupts and overflow flags are not used in the generation of INT1 interrupt. 1: Engine-generated interrupts and overflow flags are used in the generation of INT1 interrupt.
D1	R/W	0	0: ADC data-available interrupt is not used in the generation of INT1 interrupt. 1: ADC data-available interrupt is used in the generation of INT1 interrupt.
D0	R/W	0	0: INT1 is only one pulse (active high) of duration typical 2 ms. 1: INT1 is multiple pulses (active high) of duration typical 2 ms and period 4 ms, until flag register 42 or 45 is read by the user.

Table 53. Page 0 / Register 49: INT2 Interrupt Control

BIT	READ/ WRITE	RESET VALUE	DESCRIPTION
D7–D5	R	000	Reserved. Do not write any value other than reset value.
D4	R/W	0	0: ADC AGC noise interrupt is not used in the generation of INT2 interrupt. 1: ADC AGC noise interrupt is used in the generation of INT2 interrupt.
D3	R	0	Reserved. Do not write any value other than reset value.
D2	R/W	0	0: Engine-generated interrupts and overflow flags are not used in the generation of INT2 interrupt. 1: Engine-generated interrupts and overflow flags are used in the generation of INT2 interrupt.
D1	R/W	0	0: ADC data-available interrupt is not used in the generation of INT2 interrupt. 1: ADC data-available interrupt is used in the generation of INT2 interrupt.
D0	R/W	0	0: INT2 is only one pulse (active high) of duration typical 2 ms. 1: INT2 is multiple pulses (active high) of duration typical 2 ms and period 4 ms, until flag register 42 or 45 is read by the user.

Table 54. Page 0 / Register 50: Reserved

BIT	READ/ WRITE	RESET VALUE	DESCRIPTION
D7–D0	R	XXXX XXXX	Reserved. Do not write to this register.

Table 55. Page 0 / Register 51: DMCLK/GPIO2 Control

BIT	READ/ WRITE	RESET VALUE	DESCRIPTION
D7–D6	R	00	Reserved. Do not write any value other than reset value.
D5–D2	R/W	0000	0000: DMCLK disabled (input and output buffers powered down) 0001: DMCLK is in input mode (can be used as secondary BCLK input, secondary WCLK input, Dig_Mic_In, or in ClockGen block) 0010: DMCLK is used as general-purpose input (GPI) 0011: DMCLK output = general-purpose output 0100: DMCLK output = CLKOUT output (source determined by cdiv_clkin_reg; page 0 / register 25) 0101: DMCLK output = INT1 output 0110: DMCLK output = INT2 output 0111: Reserved. Do not use. 1000: DMCLK output = secondary BCLK output for codec interface 1001: DMCLK output = secondary WCLK output for codec interface 1010: DMCLK output = ADC_MOD_CLK output for the digital microphone 1011–1111: Reserved. Do not use.
D1	R	0	DMCLK input buffer value
D0	R/W	0	0: DMCLK value = 0 when D5–D2 are programmed to "0011" (general-purpose output) 1: DMCLK value = 1 when D5–D2 are programmed to "0011" (general-purpose output)

Table 56. Page 0 / Register 52: DMDIN/GPIO1 Control

BIT	READ/ WRITE	RESET VALUE	DESCRIPTION
D7–D6	R	00	Reserved. Do not write any value other than reset value.
D5–D2	R/W	0000	0000: DMDIN disabled (input and output buffers powered down) 0001: DMDIN is in input mode (can be used as secondary BCLK input, secondary WCLK input, Dig_Mic_In, or in ClockGen block) 0010: DMDIN is used as general-purpose input (GPI) 0011: DMDIN output = general-purpose output 0100: DMDIN output = CLKOUT output (source determined by cdiv_clkin_reg; page 0 / register 25) 0101: DMDIN output = INT1 output 0110: DMDIN output = INT2 output 0111: Reserved. Do not use. 1000: DMDIN output = secondary BCLK output for codec interface 1001: DMDIN output = secondary WCLK output for codec interface 1010: DMDIN output = ADC_MOD_CLK output for the digital microphone 1011–1111: Reserved. Do not use.
D1	R	0	DMDIN Input Buffer Value
D0	R/W	0	0: DMDIN value = 0 when D5–D2 are programmed to "0011" (general-purpose output) 1: DMDIN value = 1 when D5–D2 are programmed to "0011" (general-purpose output)

Table 57. Page 0 / Register 53: DOUT (OUT Pin) Control

BIT	READ/ WRITE	RESET VALUE	DESCRIPTION
D7–D5	R	000	Reserved. Do not write any value other than reset value.
D4	R/W	1	0: DOUT bus keeper enabled 1: DOUT bus keeper disabled
D3–D1	R/W	001	000: DOUT disabled (output buffer powered down) 001 DOUT = primary DOUT output for codec interface 010: DOUT = general-purpose output 011: DOUT = CLKOUT output 100: DOUT = INT1 output 101: DOUT = INT2 output 110: DOUT = secondary BCLK output for codec interface 111: DOUT = secondary WCLK output for codec interface
D0	R/W	0	DOUT value = 0 when D3–D1 are programmed to "010" (general-purpose output) DOUT value = 1 when D3–D1 are programmed to "010" (general-purpose output)

Table 58. Page 0 / Register 54 Through Page 0 / Register 56: Reserved

BIT	READ/ WRITE	RESET VALUE	DESCRIPTION
D7–D0	R	XXXX XXXX	Reserved. Do not write to this register.

Table 59. Page 0 / Register 57: ADC Sync Control 1

BIT	READ/ WRITE	RESET VALUE	DESCRIPTION
D7	R/W	0	0: Default synchronization 1: Custom synchronization
D6–D0	R/W	000 0000	000 0000: Custom synchronization window size = 0 instructions 000 0001: Custom synchronization window size = 2 instructions (±1 instruction) 000 0010: Custom synchronization window size = 4 instructions (±2 instructions) ... 111 1111: Custom synchronization window size = 254 instructions (±127 instructions)

Table 60. Page 0 / Register 58: ADC Sync Control 2

BIT	READ/ WRITE	RESET VALUE	DESCRIPTION
D7–D0	R/W	0000 0000	0000 0000: Custom synchronization target = instruction 0 0000 0001: Custom synchronization target = instruction 2 0000 0010: Custom synchronization target = instruction 4 ... 1111 1111: Custom synchronization target = instruction 510

Table 61. Page 0 / Register 59: ADC CIC Filter Gain Control

BIT	READ/ WRITE	RESET VALUE	DESCRIPTION
D7–D4	R/W	0100	Left CIC filter gain ⁽¹⁾
D3–D0	R/W	0100	Right CIC filter gain ⁽¹⁾

(1) For proper operation, CIC gain must be ≤ 1 .

If AOSR {page 0 / register 20} = 64 and $(1 \leq \text{Filter Mode \{page 0 / register 61\}} \leq 6)$, then the reset value of 4 results in CIC gain = 1. Otherwise, the CIC gain = $(\text{AOSR}/(64 \times \text{miniDSP Engine Decimation}))^4 \times 2^{(\text{CIC Filter Gain Control})}$ for $0 \leq \text{CIC Filter Gain Control} \leq 12$, and if CIC Filter Gain Control = 15, CIC gain is automatically set such that for $7 \leq (\text{AOSR}/\text{miniDSP Engine Decimation}) \leq 64$, $0.5 < \text{CIC gain} \leq 1$.

Table 62. Page 0 / Register 60: Reserved

BIT	READ/ WRITE	RESET VALUE	DESCRIPTION
D7–D0	R/W	0000 0000	Reserved. Do not write to this register.

Table 63. Page 0 / Register 61: ADC Processing Block Selection

BIT	READ/ WRITE	RESET VALUE	DESCRIPTION
D7–D5		000	Reserved. Do not write any value other than reset value.
D4–D0		0 0001	0 0000: ADC miniDSP programmable instruction mode enabled. 0 0001: Select ADC Signal Processing Block PRB_R1 0 0010: Select ADC Signal Processing Block PRB_R2 0 0011: Select ADC Signal Processing Block PRB_R3 0 0100: Select ADC Signal Processing Block PRB_R4 0 0101: Select ADC Signal Processing Block PRB_R5 0 0110: Select ADC Signal Processing Block PRB_R6 0 0111: Select ADC Signal Processing Block PRB_R7 0 1000: Select ADC Signal Processing Block PRB_R8 0 1001: Select ADC Signal Processing Block PRB_R9 0 1010: Select ADC Signal Processing Block PRB_R10 0 1011: Select ADC Signal Processing Block PRB_R11 0 1100: Select ADC Signal Processing Block PRB_R12 0 1101: Select ADC Signal Processing Block PRB_R13 0 1110: Select ADC Signal Processing Block PRB_R14 0 1111: Select ADC Signal Processing Block PRB_R15 1 0000: Select ADC Signal Processing Block PRB_R16 1 0001: Select ADC Signal Processing Block PRB_R17 1 0010: Select ADC Signal Processing Block PRB_R18 1 0011–1 1111: Reserved. Do not use.

Table 64. Page 0 / Register 62: Programmable Instruction-Mode Control Bits

BIT	READ/ WRITE	RESET VALUE	DESCRIPTION
D7	R	0	Reserved. Do not write any value other than reset value.
D6	R/W	0	ADC miniDSP engine auxiliary control bit A, which can be used for conditional instructions like JMP
D5	R/W	0	ADC miniDSP engine auxiliary control bit B, which can be used for conditional instructions like JMP
D4	R/W	0	0: ADC instruction-counter reset at the start of the new frame is enabled. 1: ADC instruction-counter reset at the start of the new frame is disabled.
D3–D0	R	0000	Reserved. Do not write any value other than reset value.

Table 65. Page 0 / Register 63 Through Page 0 / Register 79: Reserved

BIT	READ/ WRITE	RESET VALUE	DESCRIPTION
D7–D0	R	XXXX XXXX	Reserved. Do not write to these registers.

Table 66. Page 0 / Register 80: ADC Digital-Microphone Polarity Select

BIT	READ/ WRITE	RESET VALUE	DESCRIPTION
D7–D2	R	0000 00	Reserved. Do not write any value other than reset value.
D1	R/W	0	0: Capture left channel digital microphone data on rising edge of ADC modulator clock. 1: Capture left channel digital microphone data on falling edge of ADC modulator clock.
D0	R/W	0	0: Capture right channel digital microphone data on rising edge of ADC modulator clock. 1: Capture right channel digital microphone data on falling edge of ADC modulator clock.

Table 67. Page 0 / Register 81: ADC Digital

BIT	READ/ WRITE	RESET VALUE	DESCRIPTION
D7	R/W	0	0: Left-channel ADC is powered down. 1: Left-channel ADC is powered up.
D6	R/W	0	0: Right-channel ADC is powered down. 1: Right-channel ADC is powered up.
D5	R/W	0	0: Left-channel digital-microphone input is obtained from DMDIN pin. 1: Left-channel digital-microphone input is obtained from DMCLK pin.
D4	R/W	0	0: Right-channel digital-microphone input is obtained from DMDIN pin. 1: Right-channel digital-microphone input is obtained from DMCLK pin.
D3	R/W	0	0: Digital microphone is not enabled for left ADC channel. 1: Digital microphone is enabled for left ADC channel.
D2	R/W	0	0: Digital microphone is not enabled for right ADC channel. 1: Digital microphone is enabled for right ADC channel.
D1–D0	R/W	00	00: ADC channel volume control soft-stepping is enabled for one step/ f_s . 01: ADC channel volume control soft-stepping is enabled for one step/ $2f_s$. 10: ADC channel volume control soft-stepping is disabled. 11: Reserved. Do not use.

Table 68. Page 0 / Register 82: ADC Fine Volume Control

BIT	READ/ WRITE	RESET VALUE	DESCRIPTION
D7	R/W	1	0: Left ADC channel not muted 1: Left ADC channel muted
D6–D4	R/W	000	000: Left ADC channel fine gain = 0 dB 001: Left ADC channel fine gain = –0.1 dB 010: Left ADC channel fine gain = –0.2 dB 011: Left ADC channel fine gain = –0.3 dB 100: Left ADC channel fine gain = –0.4 dB 101–111: Reserved. Do not use.
D3	R/W	1	0: Right ADC channel not muted 1: Right ADC channel muted
D2–D0	R/W	000	000: Left ADC channel fine gain = 0 dB 001: Left ADC channel fine gain = –0.1 dB 010: Left ADC channel fine gain = –0.2 dB 011: Left ADC channel fine gain = –0.3 dB 100: Left ADC channel fine gain = –0.4 dB 101–111: Reserved. Do not use.

Table 69. Page 0 / Register 83: Left ADC Volume Control

BIT	READ/ WRITE	RESET VALUE ⁽¹⁾	DESCRIPTION
D7	R	0	Reserved. Do not write any value other than reset value.
D6–D0	R/W	000 0000	100 0000 – 110 1000: Left ADC channel volume = 0 dB 110 1000: Left ADC channel volume = –12 dB 110 1001: Left ADC channel volume = –11.5 dB 110 1010: Left ADC channel volume = –11.0 dB ... 111 1111: Left ADC channel volume = –0.5 dB 000 0000: Left ADC channel volume = –0.0 dB 000 0001: Left ADC channel volume = 0.5 dB ... 010 0110: Left ADC channel volume = 19.0 dB 010 0111: Left ADC channel volume = 19.5 dB 010 1000: Left ADC channel volume = 20 dB 010 1001– 011 1111 : Reserved. Do not use.

(1) Values in 2s-complement decimal format

Table 70. Page 0 / Register 84: Right ADC Volume Control

BIT	READ/ WRITE	RESET VALUE ⁽¹⁾	DESCRIPTION
D7	R	0	Reserved. Do not write any value other than reset value.
D6–D0	R/W	000 0000	100 0000 – 110 1000: Right ADC channel volume = 0 dB 110 1000: Right ADC channel volume = –12 dB 110 1001: Right ADC channel volume = –11.5 dB 110 1010: Right ADC channel volume = –11.0 dB ... 111 1111: Right ADC channel volume = –0.5 dB 000 0000: Right ADC channel volume = –0.0 dB 000 0001: Right ADC channel volume = 0.5 dB ... 010 0110: Right ADC channel volume = 19.0 dB 010 0111: Right ADC channel volume = 19.5 dB 010 1000: Right ADC channel volume = 20 dB 010 1001– 011 1111 : Reserved. Do not use.

(1) Values in 2s-complement decimal format

Table 71. Page 0 / Register 85: Left ADC Phase Compensation

BIT	READ/ WRITE	RESET VALUE	DESCRIPTION
D7–D0	R/W	0000 0000	1000 0000: Left ADC has a phase shift of –128 ADC_MOD_CLK cycles with respect to right ADC. 1000 0001: Left ADC has a phase shift of –127 ADC_MOD_CLK cycles with respect to right ADC. ... 1111 1110: Left ADC has a phase shift of –2 ADC_MOD_CLK cycles with respect to right ADC. 1111 1111: Left ADC has a phase shift of –1 ADC_MOD_CLK cycles with respect to right ADC. 0000 0000: No phase shift between stereo ADC channels 0000 0001: Left ADC has a phase shift of 1 ADC_MOD_CLK cycles with respect to right ADC. 0000 0010: Left ADC has a phase shift of 2 ADC_MOD_CLK cycles with respect to right ADC. ... 0111 1110: Left ADC has a phase shift of 126 ADC_MOD_CLK cycles with respect to right ADC. 0111 1111: Left ADC has a phase shift of 127 ADC_MOD_CLK cycles with respect to right ADC.

Table 72. Page 0 / Register 86: Left AGC Control 1

BIT	READ/ WRITE	RESET VALUE	DESCRIPTION
D7	R/W	0	0: Left AGC disabled 1: Left AGC enabled
D6–D4	R/W	000	000: Left AGC target level = –5.5 dB 001: Left AGC target level = –8 dB 010: Left AGC target level = –10 dB 011: Left AGC target level = –12 dB 100: Left AGC target level = –14 dB 101: Left AGC target level = –17 dB 110: Left AGC target level = –20 dB 111: Left AGC target level = –24 dB
D3–D0	R	0000	Reserved. Do not write any value other than reset value.

Table 73. Page 0 / Register 87: Left AGC Control 2

BIT	READ/ WRITE	RESET VALUE	DESCRIPTION
D7–D6	R/W	00	00: Left AGC hysteresis setting of 1 dB 01: Left AGC hysteresis setting of 2 dB 10: Left AGC hysteresis setting of 4 dB 11: Left AGC hysteresis disabled
D5–D1	R/W	00 000	00 000: Left AGC noise/silence detection is disabled. 00 001: Left AGC noise threshold = –30 dB 00 010: Left AGC noise threshold = –32 dB 00 011: Left AGC noise threshold = –34 dB ... 11 101: Left AGC noise threshold = –86 dB 11 110: Left AGC noise threshold = –88 dB 11 111: Left AGC noise threshold = –90 dB
D0	R/W	0	0: Disable clip stepping for AGC 1: Enable clip stepping for AGC

Table 74. Page 0 / Register 88: Left AGC Maximum Gain

BIT	READ/ WRITE	RESET VALUE	DESCRIPTION
D7	R	0	Reserved. Do not write any value other than reset value.
D6–D0	R/W	111 1111	000 0000: Left AGC maximum gain = 0 dB 000 0001: Left AGC maximum gain = 0.5 dB 000 0010: Left AGC maximum gain = 1 dB ... 101 0000: Left AGC maximum gain = 40 dB 101 0001 – 111 1111: Reserved. Do not use.

Table 75. Page 0 / Register 89: Left AGC Attack Time

BIT	READ/ WRITE	RESET VALUE	DESCRIPTION
D7–D3	R/W	0000 0	0000 0: Left AGC attack time = $1 \times (32/f_S)$ 0000 1: Left AGC attack time = $3 \times (32/f_S)$ 0001 0: Left AGC attack time = $5 \times (32/f_S)$ 0001 1: Left AGC attack time = $7 \times (32/f_S)$ 0010 0: Left AGC attack time = $9 \times (32/f_S)$... 1111 0: Left AGC attack time = $61 \times (32/f_S)$ 1111 1: Left AGC attack time = $63 \times (32/f_S)$
D2–D0	R/W	000	000: Multiply factor for the programmed left AGC attack time = 1 001: Multiply factor for the programmed left AGC attack time = 2 010: Multiply factor for the programmed left AGC attack time = 4 ... 111: Multiply factor for the programmed left AGC attack time = 128

Table 76. Page 0 / Register 90: Left AGC Decay Time

BIT	READ/ WRITE	RESET VALUE	DESCRIPTION
D7–D3	R/W	0000 0	0000 0: Left AGC decay time = $1 \times (512/f_S)$ 0000 1: Left AGC decay time = $3 \times (512/f_S)$ 0001 0: Left AGC decay time = $5 \times (512/f_S)$ 0001 1: Left AGC decay time = $7 \times (512/f_S)$ 0010 0: Left AGC decay time = $9 \times (512/f_S)$... 1111 0: Left AGC decay time = $61 \times (512/f_S)$ 1111 1: Left AGC decay time = $63 \times (512/f_S)$
D2–D0	R/W	000	000: Multiply factor for the programmed left AGC decay time = 1 001: Multiply factor for the programmed left AGC decay time = 2 010: Multiply factor for the programmed left AGC decay time = 4 ... 111: Multiply factor for the programmed left AGC decay time = 128

Table 77. Page 0 / Register 91: Left AGC Noise Debounce

BIT	READ/ WRITE	RESET VALUE	DESCRIPTION
D7–D5	R	000	Reserved. Do not write any value other than reset value.
D4–D0	R/W	0 0000	0 0000: Left AGC noise debounce = $0/f_S$ 0 0001: Left AGC noise debounce = $4/f_S$ 0 0010: Left AGC noise debounce = $8/f_S$ 0 0011: Left AGC noise debounce = $16/f_S$ 0 0100: Left AGC noise debounce = $32/f_S$ 0 0101: Left AGC noise debounce = $64/f_S$ 0 0110: Left AGC noise debounce = $128/f_S$ 0 0111: Left AGC noise debounce = $256/f_S$ 0 1000: Left AGC noise debounce = $512/f_S$ 0 1001: Left AGC noise debounce = $1024/f_S$ 0 1010: Left AGC noise debounce = $2048/f_S$ 0 1011: Left AGC noise debounce = $4096/f_S$ 0 1100: Left AGC noise debounce = $2 \times 4096/f_S$ 0 1101: Left AGC noise debounce = $3 \times 4096/f_S$ 0 1110: Left AGC noise debounce = $4 \times 4096/f_S$... 1 1110: Left AGC noise debounce = $20 \times 4096/f_S$ 1 1111: Left AGC noise debounce = $21 \times 4096/f_S$

Table 78. Page 0 / Register 92: Left AGC Signal Debounce

BIT	READ/ WRITE	RESET VALUE	DESCRIPTION
D7–D4	R	0000	Reserved. Do not write any value other than reset value.
D3–D0	R/W	0000	0000: Left AGC signal debounce = $0/f_S$ 0001: Left AGC signal debounce = $4/f_S$ 0010: Left AGC signal debounce = $8/f_S$ 0011: Left AGC signal debounce = $16/f_S$ 0100: Left AGC signal debounce = $32/f_S$ 0101: Left AGC signal debounce = $64/f_S$ 0110: Left AGC signal debounce = $128/f_S$ 0111: Left AGC signal debounce = $256/f_S$ 1000: Left AGC signal debounce = $512/f_S$ 1001: Left AGC signal debounce = $1024/f_S$ 1010: Left AGC signal debounce = $2048/f_S$ 1011: Left AGC signal debounce = $2 \times 2048/f_S$ 1100: Left AGC signal debounce = $3 \times 2048/f_S$ 1101: Left AGC signal debounce = $4 \times 2048/f_S$ 1110: Left AGC signal debounce = $5 \times 2048/f_S$ 1111: Left AGC signal debounce = $6 \times 2048/f_S$

Table 79. Page 0 / Register 93: Left AGC Gain Applied

BIT ⁽¹⁾	READ/ WRITE	RESET VALUE	DESCRIPTION
D7–D0	R	0000 0000	Left AGC Gain Value Status: 1110 1000: Gain applied by left AGC = –12 dB 1110 1001: Gain applied by left AGC = –11.5 dB ... 1111 1111: Gain applied by left AGC = –0.5 dB 0000 0000: Gain applied by left AGC = 0 dB 0000 0001: Gain applied by left AGC = 0.5 dB ... 0100 1111: Gain applied by left AGC = 39.5 dB 0101 0000: Gain applied by left AGC = 40 dB 0101 0001 – 1111 1111: Reserved. Do not use.

(1) These are read-only bits.

Table 80. Page 0 / Register 94: Right AGC Control 1

BIT	READ/ WRITE	RESET VALUE	DESCRIPTION
D7	R/W	0	0: Right AGC disabled 1: Right AGC enabled
D6–D4	R/W	000	000: Right AGC target level = –5.5 dB 000: Right AGC target level = –8 dB 001: Right AGC target level = –10 dB 010: Right AGC target level = –12 dB 011: Right AGC target level = –14 dB 100: Right AGC target level = –17 dB 101: Right AGC target level = –20 dB 111: Right AGC target level = –24 dB
D3–D0	R	0000	Reserved. Do not write any value other than reset value.

Table 81. Page 0 / Register 95: Right AGC Control 2

BIT	READ/ WRITE	RESET VALUE ⁽¹⁾	DESCRIPTION
D7–D6	R/W	00	00: Right AGC hysteresis setting of 1 dB 01: Right AGC hysteresis setting of 2 dB 10: Right AGC hysteresis setting of 4 dB 11: Right AGC hysteresis disabled.
D5–D1	R/W	00 000	00 000: Right AGC noise/silence detection is disabled. 00 001: Right AGC noise threshold = –30 dB 00 010: Right AGC noise threshold = –32 dB 00 011: Right AGC noise threshold = –34 dB ... 11 101: Right AGC noise threshold = –86 dB 11 110: Right AGC noise threshold = –88 dB 11 111: Right AGC noise threshold = –90 dB
D0	R/W	0	0: Disable clip stepping for right AGC. 1: Enable clip stepping for right AGC.

(1) Values in 2s-complement decimal format

Table 82. Page 0 / Register 96: Right AGC Maximum Gain

BIT	READ/ WRITE	RESET VALUE	DESCRIPTION
D7	R	0	Reserved. Do not write any value other than reset value.
D6–D0	R/W	111 1111	000 0000: Right AGC maximum gain = 0 dB 000 0001: Right AGC maximum gain = 0.5 dB 000 0010: Right AGC maximum gain = 1 dB ... 101 0000: Right AGC maximum gain = 40 dB 101 0001–111 1111: Not Used.

Table 83. Page 0 / Register 97: Right AGC Attack Time

BIT	READ/ WRITE	RESET VALUE	DESCRIPTION
D7–D3	R/W	0000 0	0000 0: Right AGC attack time = $1 \times (32/f_S)$ 0000 1: Right AGC attack time = $3 \times (32/f_S)$ 0001 0: Right AGC attack time = $5 \times (32/f_S)$ 0001 1: Right AGC attack time = $7 \times (32/f_S)$ 0010 0: Right AGC attack time = $9 \times (32/f_S)$... 1111 0: Right AGC attack time = $61 \times (32/f_S)$ 1111 1: Right AGC attack time = $63 \times (32/f_S)$
D2–D0	R/W	000	000: Multiply factor for the programmed right AGC attack time = 1 001: Multiply factor for the programmed right AGC attack time = 2 010: Multiply factor for the programmed right AGC attack time = 4 ... 111: Multiply factor for the programmed right AGC attack time = 128

Table 84. Page 0 / Register 98: Right AGC Decay Time

BIT	READ/ WRITE	RESET VALUE	DESCRIPTION
D7–D3	R/W	0000 0	0000 0: Right AGC decay time = $1 \times (512/f_S)$ 0000 1: Right AGC decay time = $3 \times (512/f_S)$ 0001 0: Right AGC decay time = $5 \times (512/f_S)$ 0001 1: Right AGC decay time = $7 \times (512/f_S)$ 0010 0: Right AGC decay time = $9 \times (512/f_S)$... 1111 0: Right AGC decay time = $61 \times (512/f_S)$ 1111 1: Right AGC decay time = $63 \times (512/f_S)$
D2–D0	R/W	000	000: Multiply factor for the programmed right AGC decay time = 1 001: Multiply factor for the programmed right AGC decay time = 2 010: Multiply factor for the programmed right AGC decay time = 4 111: Multiply factor for the programmed right AGC decay time = 128

Table 85. Page 0 / Register 99: Right AGC Noise Debounce

BIT	READ/ WRITE	RESET VALUE	DESCRIPTION
D7–D5	R	000	Reserved. Do not write any value other than reset value.
D4–D0	R/W	0 0000	0 0000: Right AGC noise debounce = $0/f_S$ 0 0001: Right AGC noise debounce = $4/f_S$ 0 0010: Right AGC noise debounce = $8/f_S$ 0 0011: Right AGC noise debounce = $16/f_S$ 0 0100: Right AGC noise debounce = $32/f_S$ 0 0101: Right AGC noise debounce = $64/f_S$ 0 0110: Right AGC noise debounce = $128/f_S$ 0 0111: Right AGC noise debounce = $256/f_S$ 0 1000: Right AGC noise debounce = $512/f_S$ 0 1001: Right AGC noise debounce = $1024/f_S$ 0 1010: Right AGC noise debounce = $2048/f_S$ 0 1011: Right AGC noise debounce = $4096/f_S$ 0 1100: Right AGC noise debounce = $2 \times 4096/f_S$ 0 1101: Right AGC noise debounce = $3 \times 4096/f_S$ 0 1110: Right AGC noise debounce = $4 \times 4096/f_S$... 1 1110: Right AGC noise debounce = $20 \times 4096/f_S$ 1 1111: Right AGC noise debounce = $21 \times 4096/f_S$ Right AGC noise debounce = $0/f_S$

Table 86. Page 0 / Register 100: Right AGC Signal Debounce

BIT	READ/ WRITE	RESET VALUE	DESCRIPTION
D7–D4	R	0000	Reserved. Do not write any value other than reset value.
D3–D0	R/W	0000	0000: Right AGC signal debounce = $0/f_S$ 0001: Right AGC signal debounce = $4/f_S$ 0010: Right AGC signal debounce = $8/f_S$ 0011: Right AGC signal debounce = $16/f_S$ 0100: Right AGC signal debounce = $32/f_S$ 0101: Right AGC signal debounce = $64/f_S$ 0110: Right AGC signal debounce = $128/f_S$ 0111: Right AGC signal debounce = $256/f_S$ 1000: Right AGC signal debounce = $512/f_S$ 1001: Right AGC signal debounce = $1024/f_S$ 1010: Right AGC signal debounce = $2048/f_S$ 1011: Right AGC signal debounce = $2 \times 2048/f_S$ 1100: Right AGC signal debounce = $3 \times 2048/f_S$ 1101: Right AGC signal debounce = $4 \times 2048/f_S$ 1110: Right AGC signal debounce = $5 \times 2048/f_S$ 1111: Right AGC signal debounce = $6 \times 2048/f_S$ Right AGC signal debounce = $0/f_S$

Table 87. Page 0 / Register 101: Right AGC Gain Applied

BIT ⁽¹⁾	READ/ WRITE	RESET VALUE	DESCRIPTION
D7–D0	R	0000 0000	Right AGC Gain Value Status: 1110 1000: Gain applied by right AGC = –12 dB 1110 1001: Gain applied by right AGC = –11.5 dB ... 1111 1111: Gain applied by right AGC = –0.5 dB 0000 0000: Gain applied by right AGC = 0 dB 0000 0001: Gain applied by right AGC = 0.5 dB ... 0100 1111: Gain applied by right AGC = 39.5 dB 0101 0000: Gain applied by right AGC = 40 dB 0101 0001 – 1111 1111: Reserved. Do not use.

(1) These are read-only bits.

Table 88. Page 0 / Register 102 Through Page 0 / Register 127: Reserved

BIT	READ/ WRITE	RESET VALUE	DESCRIPTION
D7–D0	R	XXXX XXXX	Reserved. Do not write to these registers.

10.6.3 CONTROL REGISTERS Page 1: ADC Routing, PGA, Power-Controls, Etc.

Table 89. Page 1 / Register 0: Page Control Register⁽¹⁾

BIT	READ/ WRITE	RESET VALUE	DESCRIPTION
D7–D0	R/W	0000 0000	0000 0000: Page 0 selected 0000 0001: Page 1 selected ... 1111 1110: Page 254 selected (reserved) 1111 1111: Page 255 selected (reserved)

(1) Valid pages are 0, 1, 4, 5, 32-47. All other pages are reserved (do not access).

Table 90. Page 1 / Register 1 Through Page 1 / Register 25: Reserved

BIT	READ/ WRITE	RESET VALUE	DESCRIPTION
D7–D0	R	XXXX XXXX	Reserved. Do not write to these registers.

Table 91. Page 1 / Register 26: Dither Control

BIT	READ/ WRITE	RESET VALUE	DESCRIPTION
D7–D4	R/W	0000	DC Offset Into Input of Left ADC; Signed Magnitude Number In ± 15 -mV Steps 1111: –105 mV ... 1011: –45 mV 1010: –30 mV 1001: –15 mV 0000: 0 mV 0001: 15 mV 0010: 30 mV 0011: 45 mV ... 0111: 105 mV
D3–D0	R/W	0000	DC Offset Into Input of Right ADC; Signed Magnitude Number In ± 15 -mV Steps 1111: –105 mV ... 1011: –45 mV 1010: –30 mV 1001: –15 mV 0000: 0 mV 0001: 15 mV 0010: 30 mV 0011: 45 mV ... 0111: 105 mV

Table 92. Page 1 / Register 27 Through Page 1 / Register 50: Reserved

BIT	READ/ WRITE	RESET VALUE	DESCRIPTION
D7–D0	R	XXXX XXXX	Reserved. Do not write to these registers.

Table 93. Page 1 / Register 51: MICBIAS Control

BIT	READ/ WRITE	RESET VALUE	DESCRIPTION
D7	R	0	Reserved. Do not write any value other than reset value.
D6 – D5	R/W	00	00: MICBIAS1 is powered down. 01: MICBIAS1 is powered to 2 V. 10: MICBIAS1 is powered to 2.5 V. 11: MICBIAS1 is connected to AVDD.
D4 – D3	R/W	00	00: MICBIAS2 is powered down. 01: MICBIAS2 is powered to 2 V. 10: MICBIAS2 is powered to 2.5 V. 11: MICBIAS2 is connected to AVDD.
D2–D0	R	000	Reserved. Do not write any value other than reset value.

Table 94. Page 1 / Register 52: Left ADC Input Selection for Left PGA

BIT	READ/ WRITE	RESET VALUE	DESCRIPTION ⁽¹⁾
D7–D6	R/W	11	LCH_SEL4; Differential Pair Using the IN2L(P) as PLUS and IN3L(M) as MINUS Inputs 00: 0-dB setting is chosen. 01: –6-dB setting is chosen. 10: Is not connected to the left ADC PGA 11: Is not connected to the left ADC PGA
D5–D4	R/W	11	LCH_SEL3; Used for the IN3L(M) Pin, Which Is Single-Ended 00: 0-dB setting is chosen. 01: –6-dB setting is chosen. 10: Is not connected to the left ADC PGA 11: Is not connected to the left ADC PGA
D3–D2	R/W	11	LCH_SEL2; Used for the IN2L(P) Pin, Which Is Single-Ended 00: 0-dB setting is chosen. 01: –6-dB setting is chosen. 10: Is not connected to the left ADC PGA 11: Is not connected to the left ADC PGA
D1–D0	R/W	11	LCH_SEL1; Used for the IN1L(P) Pin, Which Is Single-Ended 00: 0-dB setting is chosen. 01: –6-dB setting is chosen. 10: Is not connected to the left ADC PGA 11: Is not connected to the left ADC PGA

(1) To maintain the same PGA output level for both single-ended and differential pairs, the single-ended inputs have a 2x gain applied.

Table 95. Page 1 / Register 53: Reserved

BIT	READ/ WRITE	RESET VALUE	DESCRIPTION
D7–D0	R	XXXX XXXX	Reserved. Do not write to this register.

Table 96. Page 1 / Register 54: Left ADC Input Selection for Left PGA

BIT	READ/ WRITE	RESET VALUE	DESCRIPTION ⁽¹⁾
D7	R/W	0	0: Do not bypass left PGA. 1: Bypass left PGA, unbuffered differential pair using the IN2L(P) as PLUS and IN3L(M) as MINUS inputs.
D6	R/W	0	LCH_SEL3CM 0: Left ADC channel unselected inputs are not biased weakly to the ADC common-mode voltage. 1: Left ADC channel unselected inputs are biased weakly to the ADC common-mode voltage.
D5–D4	R/W	11	LCH_SEL3X; Differential Pair Using the IN1L(P) as PLUS and IN1R(M) as MINUS Inputs. 00: 0-dB setting is chosen. 01: –6-dB setting is chosen. 10–11: Not connected to the left ADC PGA
D3–D2	R/W	11	LCH_SEL2X; Differential Pair Using the IN2R(P) as PLUS and IN3R(M) as MINUS Inputs. 00: 0-dB setting is chosen. 01: –6-dB setting is chosen. 10–11: Is not connected to the left ADC PGA.
D1–D0	R/W	11	LCH_SEL1X; Used for the IN1R(M) Pin, Which Is Single-Ended 00: 0 dB setting is chosen. 01: –6 dB setting is chosen. 10–11: Not connected to the left ADC PGA.

(1) To maintain the same PGA output level for both single-ended and differential pairs, the single-ended inputs have a 2x gain applied.

Table 97. Page 1 / Register 55: Right ADC Input selection for Right PGA

BIT	READ/ WRITE	RESET VALUE	DESCRIPTION ⁽¹⁾
D7–D6	R/W	11	RCH_SEL4; Differential Pair Using the IN2R(P) as PLUS and IN3R(M) as MINUS Inputs. 00: 0-dB setting is chosen. 01: –6-dB setting is chosen. 10–11: Not connected to the right ADC PGA.
D5–D4	R/W	11	RCH_SEL3; Used for the IN3R(M) Pin, Which Is Single-Ended 00: 0-dB setting is chosen. 01: –6-dB setting is chosen. 10–11: Not connected to the right ADC PGA.
D3–D2	R/W	11	RCH_SEL2; Used for the IN2R(P) Pin, Which Is Single-Ended 00: 0-dB setting is chosen. 01: –6-dB setting is chosen. 10–11: Not connected to the right ADC PGA.
D1–D0	R/W	11	RCH_SEL1; Used for the IN1R(M) Pin, Which Is Single-Ended 00: 0-dB setting is chosen. 01: –6-dB setting is chosen. 10–11: Not connected to the right ADC PGA.

(1) To maintain the same PGA output level for both single-ended and differential pairs, the single-ended inputs have a 2x gain applied.

Table 98. Page 1 / Register 56: Reserved

BIT	READ/ WRITE	RESET VALUE	DESCRIPTION
D7–D0	R	XXXX XXXX	Reserved. Do not write to this register.

Table 99. Page 1 / Register 57: Right ADC Input selection for Right PGA

BIT	READ/ WRITE	RESET VALUE	DESCRIPTION ⁽¹⁾
D7	R/W	0	0: Do not bypass right PGA. 1: Bypass right PGA, unbuffered differential pair using the IN2R(P) as PLUS and IN3R(M) as MINUS inputs.
D6	R/W	0	RCH_SEL3CM 0: Right ADC channel unselected inputs are not biased weakly to the ADC common-mode voltage. 1: Right ADC channel unselected inputs are biased weakly to the ADC common-mode voltage.
D5–D4	R/W	11	RCH_SEL3X; Differential Pair Using the IN1L(P) as PLUS and IN1R(M) as MINUS Inputs. 00: 0-dB setting is chosen. 01: –6 dB setting is chosen. 10–11: Not connected to the right ADC PGA
D3–D2	R/W	11	RCH_SEL2X; Differential Pair Using the IN2L(P) as PLUS and IN3L(M) as MINUS Inputs. 00: 0-dB setting is chosen. 01: –6-dB setting is chosen. 10–11: Not connected to the right ADC PGA
D1–D0	R/W	11	RCH_SEL1X; Used for the IN1L(P) Pin, Which Is Single-Ended 00: 0-dB setting is chosen. 01: –6-dB setting is chosen. 10–11: Not connected to the right ADC PGA

(1) To maintain the same PGA output level for both single-ended and differential pairs, the single-ended inputs have a 2x gain applied.

Table 100. Page 1 / Register 58: Reserved

BIT	READ/ WRITE	RESET VALUE	DESCRIPTION
D7–D0	R	XXXX XXXX	Reserved. Do not write to this register.

Table 101. Page 1 / Register 59: Left Analog PGA Settings

BIT	READ/ WRITE	RESET VALUE	DESCRIPTION
D7	R/W	1	0: Left PGA is not muted. 1: Left PGA is muted.
D6–D0	R/W	000 0000	000 0000: Left PGA gain = 0 dB 000 0001: Left PGA gain = 0.5 dB 000 0010: Left PGA gain = 1 dB ... 101 0000: Left PGA gain = 40 dB 101 0001–111 1111: Reserved. Do not use.

Table 102. Page 1 / Register 60: Right Analog PGA Settings

BIT	READ/ WRITE	RESET VALUE	DESCRIPTION
D7	R/W	1	0: Right PGA is not muted 1: Right PGA is muted
D6–D0	R/W	000 0000	000 0000: Right PGA gain = 0 dB 000 0001: Right PGA gain = 0.5 dB 000 010: Right PGA gain = 1 dB ... 101 0000: Right PGA gain = 40 dB 101 0001–111 1111: Reserved. Do not use.

Table 103. Page 1 / Register 61: ADC Low Current Modes

BIT	READ/ WRITE	RESET VALUE	DESCRIPTION
D7–D1	R	0000 000	Reserved. Write only zeros to these bits.
D0	R/W	0	0: 1× ADC modulator current used 1: 0.5× ADC modulator current used

Table 104. Page 1 / Register 62: ADC Analog PGA Flags

BIT	READ/ WRITE	RESET VALUE	DESCRIPTION
D7–D2	R	0000 00	Reserved, don't write any value other than reset value
D1	R	0	0: Left ADC PGA , applied gain ≠ programmed gain 1: Left ADC PGA , applied gain = programmed gain
D0	R	0	0: Right ADC PGA , applied gain ≠ programmed gain 1: Right ADC PGA , applied gain = programmed gain

Table 105. Page 1 / Register 63 Through Page 1 / Register 127: Reserved

BIT	READ/ WRITE	RESET VALUE	DESCRIPTION
D7–D0	R	XXXX XXXX	Reserved. Do not write to these registers.

10.6.4 Control Registers, Page 4: ADC Digital Filter Coefficients

Default values shown for this page only become valid 100 μs following a hardware or software reset.

Table 106. Page 4 / Register 0: Page Control Register⁽¹⁾

BIT	READ/ WRITE	RESET VALUE	DESCRIPTION
D7–D0	R/W	0000 0000	0000 0000: Page 0 selected 0000 0001: Page 1 selected ... 1111 1110: Page 254 selected (reserved) 1111 1111: Page 255 selected (reserved)

(1) Valid pages are 0, 1, 4, 5, 32-47. All other pages are reserved (do not access).

The remaining page 4 registers are either reserved registers or are used for setting coefficients for the various filters in the processing blocks. Reserved registers must not be written to.

The filter coefficient registers are arranged in pairs, with two adjacent 8-bit registers containing the 16-bit coefficient for a single filter. The 16-bit integer contained in the MSB and LSB registers for a coefficient are interpreted as a 2s-complement integer, with possible values ranging from $-32,768$ to $32,767$. When programming any coefficient value for a filter, the MSB register must always be written first, immediately followed by the LSB register. Even if only the MSB or LSB portion of the coefficient changes, both registers must be written in this sequence. [Table 107](#) is a list of the page 4 registers, excepting the previously described register 0.

Table 107. Page 4 Registers

REGISTER NUMBER	RESET VALUE	REGISTER NAME
1	XXXX XXXX	Reserved. Do not write to this register.
2	0000 0001	Coefficient N0(15:8) for AGC LPF (first-order IIR) used as averager to detect level or Coefficient C1(15:8) of ADC miniDSP
3	0001 0111	Coefficient N0(7:0) for AGC LPF (first-order IIR) used as averager to detect level or Coefficient C1(7:0) of ADC miniDSP
4	0000 0001	Coefficient N1(15:8) for AGC LPF (first-order IIR) used as averager to detect level or Coefficient C2(15:8) of ADC miniDSP
5	0001 0111	Coefficient N1(7:0) for AGC LPF (first-order IIR) used as averager to detect level or Coefficient C2(7:0) of ADC miniDSP
6	0111 1101	Coefficient D1(15:8) for AGC LPF (first-order IIR) used as averager to detect level or Coefficient C3(15:8) of ADC miniDSP
7	1101 0011	Coefficient D1(7:0) for AGC LPF (first-order IIR) used as averager to detect level or Coefficient C3(7:0) of ADC miniDSP
8	0111 1111	Coefficient N0(15:8) for Left ADC programmable first-order IIR or Coefficient C4(15:8) of ADC miniDSP
9	1111 1111	Coefficient N0(7:0) for Left ADC programmable first-order IIR or Coefficient C4(7:0) of ADC miniDSP
10	0000 0000	Coefficient N1(15:8) for Left ADC programmable first-order IIR or Coefficient C5(15:8) of ADC miniDSP
11	0000 0000	Coefficient N1(7:0) for Left ADC programmable first-order IIR or Coefficient C5(7:0) of ADC miniDSP
12	0000 0000	Coefficient D1(15:8) for Left ADC programmable first-order IIR or Coefficient C6(15:8) of ADC miniDSP
13	0000 0000	Coefficient D1(7:0) for Left ADC programmable first-order IIR or Coefficient C6(7:0) of ADC miniDSP
14	0111 1111	Coefficient N0(15:8) for Left ADC Biquad A or Coefficient FIR0(15:8) for ADC FIR Filter or Coefficient C7(15:8) of ADC miniDSP
15	1111 1111	Coefficient N0(7:0) for Left ADC Biquad A or Coefficient FIR0(7:0) for ADC FIR Filter or Coefficient C7(7:0) of ADC miniDSP
16	0000 0000	Coefficient N1(15:8) for Left ADC Biquad A or Coefficient FIR1(15:8) for ADC FIR Filter or Coefficient C8(15:8) of ADC miniDSP
17	0000 0000	Coefficient N1(7:0) for Left ADC Biquad A or Coefficient FIR1(7:0) for ADC FIR Filter or Coefficient C8(7:0) of ADC miniDSP
18	0000 0000	Coefficient N2(15:8) for Left ADC Biquad A or Coefficient FIR2(15:8) for ADC FIR Filter or Coefficient C9(15:8) of ADC miniDSP
19	0000 0000	Coefficient N2(7:0) for Left ADC Biquad A or Coefficient FIR2(7:0) for ADC FIR Filter or Coefficient C9(7:0) of ADC miniDSP
20	0000 0000	Coefficient D1(15:8) for Left ADC Biquad A or Coefficient FIR3(15:8) for ADC FIR Filter or Coefficient C10(15:8) of ADC miniDSP
21	0000 0000	Coefficient D1(7:0) for Left ADC Biquad A or Coefficient FIR3(7:0) for ADC FIR Filter or Coefficient C10(7:0) of ADC miniDSP
22	0000 0000	Coefficient D2(15:8) for Left ADC Biquad A or Coefficient FIR4(15:8) for ADC FIR Filter or Coefficient C11(15:8) of ADC miniDSP
23	0000 0000	Coefficient D2(7:0) for Left ADC Biquad A or Coefficient FIR4(7:0) for ADC FIR Filter or Coefficient C11(7:0) of ADC miniDSP

Table 107. Page 4 Registers (continued)

REGISTER NUMBER	RESET VALUE	REGISTER NAME
24	0111 1111	Coefficient N0(15:8) for Left ADC Biquad B or Coefficient FIR5(15:8) for ADC FIR Filter or Coefficient C12(15:8) of ADC miniDSP
25	1111 1111	Coefficient N0(7:0) for Left ADC Biquad B or Coefficient FIR5(7:0) for ADC FIR Filter or Coefficient C12(7:0) of ADC miniDSP
26	0000 0000	Coefficient N1(15:8) for Left ADC Biquad B or Coefficient FIR6(15:8) for ADC FIR Filter or Coefficient C13(15:8) of ADC miniDSP
27	0000 0000	Coefficient N1(7:0) for Left ADC Biquad B or Coefficient FIR6(7:0) for ADC FIR Filter or Coefficient C13(7:0) of ADC miniDSP
28	0000 0000	Coefficient N2(15:8) for Left ADC Biquad B or Coefficient FIR7(15:8) for ADC FIR Filter or Coefficient C14(15:8) of ADC miniDSP
29	0000 0000	Coefficient N2(7:0) for Left ADC Biquad B or Coefficient FIR7(7:0) for ADC FIR Filter or Coefficient C14(7:0) of ADC miniDSP
30	0000 0000	Coefficient D1(15:8) for Left ADC Biquad B or Coefficient FIR8(15:8) for ADC FIR Filter or Coefficient C15(15:8) of ADC miniDSP
31	0000 0000	Coefficient D1(7:0) for Left ADC Biquad B or Coefficient FIR8(7:0) for ADC FIR Filter or Coefficient C15(7:0) of ADC miniDSP
32	0000 0000	Coefficient D2(15:8) for Left ADC Biquad B or Coefficient FIR9(15:8) for ADC FIR Filter or Coefficient C16(15:8) of ADC miniDSP
33	0000 0000	Coefficient D2(7:0) for Left ADC Biquad B or Coefficient FIR9(7:0) for ADC FIR Filter or Coefficient C16(7:0) of ADC miniDSP
34	0111 1111	Coefficient N0(15:8) for Left ADC Biquad C or Coefficient FIR10(15:8) for ADC FIR Filter or Coefficient C17(15:8) of ADC miniDSP
35	1111 1111	Coefficient N0(7:0) for Left ADC Biquad C or Coefficient FIR10(7:0) for ADC FIR Filter or Coefficient C17(7:0) of ADC miniDSP
36	0000 0000	Coefficient N1(15:8) for Left ADC Biquad C or Coefficient FIR11(15:8) for ADC FIR Filter or Coefficient C18(15:8) of ADC miniDSP
37	0000 0000	Coefficient N1(7:0) for Left ADC Biquad C or Coefficient FIR11(7:0) for ADC FIR Filter or Coefficient C18(7:0) of ADC miniDSP
38	0000 0000	Coefficient N2(15:8) for Left ADC Biquad C or Coefficient FIR12(15:8) for ADC FIR Filter or Coefficient C19(15:8) of ADC miniDSP
39	0000 0000	Coefficient N2(7:0) for Left ADC Biquad C or Coefficient FIR12(7:0) for ADC FIR Filter or Coefficient C19(7:0) of ADC miniDSP
40	0000 0000	Coefficient D1(15:8) for Left ADC Biquad C or Coefficient FIR13(15:8) for ADC FIR Filter or Coefficient C20(15:8) of ADC miniDSP
41	0000 0000	Coefficient D1(7:0) for Left ADC Biquad C or Coefficient FIR13(7:0) for ADC FIR Filter or Coefficient C20(7:0) of ADC miniDSP
42	0000 0000	Coefficient D2(15:8) for Left ADC Biquad C or Coefficient FIR14(15:8) for ADC FIR Filter or Coefficient C21(15:8) of ADC miniDSP
43	0000 0000	Coefficient D2(7:0) for Left ADC Biquad C or Coefficient FIR14(7:0) for ADC FIR Filter or Coefficient C21(7:0) of ADC miniDSP
44	0111 1111	Coefficient N0(15:8) for Left ADC Biquad D or Coefficient FIR15(15:8) for ADC FIR Filter or Coefficient C22(15:8) of ADC miniDSP
45	1111 1111	Coefficient N0(7:0) for Left ADC Biquad D or Coefficient FIR15(7:0) for ADC FIR Filter or Coefficient C22(7:0) of ADC miniDSP
46	0000 0000	Coefficient N1(15:8) for Left ADC Biquad D or Coefficient FIR16(15:8) for ADC FIR Filter or Coefficient C23(15:8) of ADC miniDSP
47	0000 0000	Coefficient N1(7:0) for Left ADC Biquad D or Coefficient FIR16(7:0) for ADC FIR Filter or Coefficient C23(7:0) of ADC miniDSP
48	0000 0000	Coefficient N2(15:8) for Left ADC Biquad D or Coefficient FIR17(15:8) for ADC FIR Filter or Coefficient C24(15:8) of ADC miniDSP
49	0000 0000	Coefficient N2(7:0) for Left ADC Biquad D or Coefficient FIR17(7:0) for ADC FIR Filter or Coefficient C24(7:0) of ADC miniDSP
50	0000 0000	Coefficient D1(15:8) for Left ADC Biquad D or Coefficient FIR18(15:8) for ADC FIR Filter or Coefficient C25(15:8) of ADC miniDSP

Table 107. Page 4 Registers (continued)

REGISTER NUMBER	RESET VALUE	REGISTER NAME
51	0000 0000	Coefficient D1(7:0) for Left ADC Biquad D or Coefficient FIR18(7:0) for ADC FIR Filter or Coefficient C25(7:0) of ADC miniDSP
52	0000 0000	Coefficient D2(15:8) for Left ADC Biquad D or Coefficient FIR19(15:8) for ADC FIR Filter or Coefficient C26(15:8) of ADC miniDSP
53	0000 0000	Coefficient D2(7:0) for Left ADC Biquad D or Coefficient FIR19(7:0) for ADC FIR Filter or Coefficient C26(7:0) of ADC miniDSP
54	0111 1111	Coefficient N0(15:8) for Left ADC Biquad E or Coefficient FIR20(15:8) for ADC FIR Filter or Coefficient C27(15:8) of ADC miniDSP
55	1111 1111	Coefficient N0(7:0) for Left ADC Biquad E or Coefficient FIR20(7:0) for ADC FIR Filter or Coefficient C27(7:0) of ADC miniDSP
56	0000 0000	Coefficient N1(15:8) for Left ADC Biquad E or Coefficient FIR21(15:8) for ADC FIR Filter or Coefficient C28(15:8) of ADC miniDSP
57	0000 0000	Coefficient N1(7:0) for Left ADC Biquad E or Coefficient FIR21(7:0) for ADC FIR Filter or Coefficient C28(7:0) of ADC miniDSP
58	0000 0000	Coefficient N2(15:8) for Left ADC Biquad E or Coefficient FIR22(15:8) for ADC FIR Filter or Coefficient C29(15:8) of ADC miniDSP
59	0000 0000	Coefficient N2(7:0) for Left ADC Biquad E or Coefficient FIR22(7:0) for ADC FIR Filter or Coefficient C29(7:0) of ADC miniDSP
60	0000 0000	Coefficient D1(15:8) for Left ADC Biquad E or Coefficient FIR23(15:8) for ADC FIR Filter or Coefficient C30(15:8) of ADC miniDSP
61	0000 0000	Coefficient D1(7:0) for Left ADC Biquad E or Coefficient FIR23(7:0) for ADC FIR Filter or Coefficient C30(7:0) of ADC miniDSP
62	0000 0000	Coefficient D2(15:8) for Left ADC Biquad E or Coefficient FIR24(15:8) for ADC FIR Filter or Coefficient C31(15:8) of ADC miniDSP
63	0000 0000	Coefficient D2(7:0) for Left ADC Biquad E or Coefficient FIR24(7:0) for ADC FIR Filter or Coefficient C31(7:0) of ADC miniDSP
64	0000 0000	Coefficient C32(15:8) of ADC miniDSP
65	0000 0000	Coefficient C32(7:0) of ADC miniDSP
66	0000 0000	Coefficient C33(15:8) of ADC miniDSP
67	0000 0000	Coefficient C33(7:0) of ADC miniDSP
68	0000 0000	Coefficient C34(15:8) of ADC miniDSP
69	0000 0000	Coefficient C34(7:0) of ADC miniDSP
70	0000 0000	Coefficient C35(15:8) of ADC miniDSP
71	0000 0000	Coefficient C35(7:0) of ADC miniDSP
72	0000 0000	Coefficient N0(15:8) for Right ADC programmable first-order IIR or Coefficient C36(15:8) of ADC miniDSP
73	0000 0000	Coefficient N0(7:0) for Right ADC programmable first-order IIR or Coefficient C36(7:0) of ADC miniDSP
74	0000 0000	Coefficient N1(15:8) for Right ADC programmable first-order IIR or Coefficient C37(15:8) of ADC miniDSP
75	0000 0000	Coefficient N1(7:0) for Right ADC programmable first-order IIR or Coefficient C37(7:0) of ADC miniDSP
76	0000 0000	Coefficient D1(15:8) for Right ADC programmable first-order IIR or Coefficient C38(15:8) of ADC miniDSP
77	0000 0000	Coefficient D1(7:0) for Right ADC programmable first-order IIR or Coefficient C38(7:0) of ADC miniDSP
78	0000 0000	Coefficient N0(15:8) for Right ADC Biquad A or Coefficient FIR0(15:8) for ADC FIR Filter or Coefficient C39(15:8) of ADC miniDSP
79	0000 0000	Coefficient N0(7:0) for Right ADC Biquad A or Coefficient FIR0(7:0) for ADC FIR Filter or Coefficient C39(7:0) of ADC miniDSP
80	0000 0000	Coefficient N1(15:8) for Right ADC Biquad A or Coefficient FIR1(15:8) for ADC FIR Filter or Coefficient C40(15:8) of ADC miniDSP
81	0000 0000	Coefficient N1(7:0) for Right ADC Biquad A or Coefficient FIR1(7:0) for ADC FIR Filter or Coefficient C40(7:0) of ADC miniDSP

Table 107. Page 4 Registers (continued)

REGISTER NUMBER	RESET VALUE	REGISTER NAME
82	0000 0000	Coefficient N2(15:8) for Right ADC Biquad A or Coefficient FIR2(15:8) for ADC FIR Filter or Coefficient C41(15:8) of ADC miniDSP
83	0000 0000	Coefficient N2(7:0) for Right ADC Biquad A or Coefficient FIR2(7:0) for ADC FIR Filter or Coefficient C41(7:0) of ADC miniDSP
84	0000 0000	Coefficient D1(15:8) for Right ADC Biquad A or Coefficient FIR3(15:8) for ADC FIR Filter or Coefficient C42(15:8) of ADC miniDSP
85	0000 0000	Coefficient D1(7:0) for Right ADC Biquad A or Coefficient FIR3(7:0) for ADC FIR Filter or Coefficient C42(7:0) of ADC miniDSP
86	0000 0000	Coefficient D2(15:8) for Right ADC Biquad A or Coefficient FIR4(15:8) for ADC FIR Filter or Coefficient C43(15:8) of ADC miniDSP
87	0000 0000	Coefficient D2(7:0) for Right ADC Biquad A or Coefficient FIR4(7:0) for ADC FIR Filter or Coefficient C43(7:0) of ADC miniDSP
88	0000 0000	Coefficient N0(15:8) for Right ADC Biquad B or Coefficient FIR5(15:8) for ADC FIR Filter or Coefficient C44(15:8) of ADC miniDSP
89	0000 0000	Coefficient N0(7:0) for Right ADC Biquad B or Coefficient FIR5(7:0) for ADC FIR Filter or Coefficient C44(7:0) of ADC miniDSP
90	0000 0000	Coefficient N1(15:8) for Right ADC Biquad B or Coefficient FIR6(15:8) for ADC FIR Filter or Coefficient C45(15:8) of ADC miniDSP
91	0000 0000	Coefficient N1(7:0) for Right ADC Biquad B or Coefficient FIR6(7:0) for ADC FIR Filter or Coefficient C45(7:0) of ADC miniDSP
92	0000 0000	Coefficient N2(15:8) for Right ADC Biquad B or Coefficient FIR7(15:8) for ADC FIR Filter or Coefficient C46(15:8) of ADC miniDSP
93	0000 0000	Coefficient N2(7:0) for Right ADC Biquad B or Coefficient FIR7(7:0) for ADC FIR Filter or Coefficient C46(7:0) of ADC miniDSP
94	0000 0000	Coefficient D1(15:8) for Right ADC Biquad B or Coefficient FIR8(15:8) for ADC FIR Filter or Coefficient C47(15:8) of ADC miniDSP
95	0000 0000	Coefficient D1(7:0) for Right ADC Biquad B or Coefficient FIR8(7:0) for ADC FIR Filter or Coefficient C47(7:0) of ADC miniDSP
96	0000 0000	Coefficient D2(15:8) for Right ADC Biquad B or Coefficient FIR9(15:8) for ADC FIR Filter or Coefficient C48(15:8) of ADC miniDSP
97	0000 0000	Coefficient D2(7:0) for Right ADC Biquad B or Coefficient FIR9(7:0) for ADC FIR Filter or Coefficient C48(7:0) of ADC miniDSP
98	0000 0000	Coefficient N0(15:8) for Right ADC Biquad C or Coefficient FIR10(15:8) for ADC FIR Filter or Coefficient C49(15:8) of ADC miniDSP
99	0000 0000	Coefficient N0(7:0) for Right ADC Biquad C or Coefficient FIR10(7:0) for ADC FIR Filter or Coefficient C49(7:0) of ADC miniDSP
100	0000 0000	Coefficient N1(15:8) for Right ADC Biquad C or Coefficient FIR11(15:8) for ADC FIR Filter or Coefficient C50(15:8) of ADC miniDSP
101	0000 0000	Coefficient N1(7:0) for Right ADC Biquad C or Coefficient FIR11(7:0) for ADC FIR Filter or Coefficient C50(7:0) of ADC miniDSP
102	0000 0000	Coefficient N2(15:8) for Right ADC Biquad C or Coefficient FIR12(15:8) for ADC FIR Filter or Coefficient C51(15:8) of ADC miniDSP
103	0000 0000	Coefficient N2(7:0) for Right ADC Biquad C or Coefficient FIR12(7:0) for ADC FIR Filter or Coefficient C51(7:0) of ADC miniDSP
104	0000 0000	Coefficient D1(15:8) for Right ADC Biquad C or Coefficient FIR13(15:8) for ADC FIR Filter or Coefficient C52(15:8) of ADC miniDSP
105	0000 0000	Coefficient D1(7:0) for Right ADC Biquad C or Coefficient FIR13(7:0) for ADC FIR Filter or Coefficient C52(7:0) of ADC miniDSP
106	0000 0000	Coefficient D2(15:8) for Right ADC Biquad C or Coefficient FIR14(15:8) for ADC FIR Filter or Coefficient C53(15:8) of ADC miniDSP
107	0000 0000	Coefficient D2(7:0) for Right ADC Biquad C or Coefficient FIR14(7:0) for ADC FIR Filter or Coefficient C53(7:0) of ADC miniDSP
108	0000 0000	Coefficient N0(15:8) for Right ADC Biquad D or Coefficient FIR15(15:8) for ADC FIR Filter or Coefficient C54(15:8) of ADC miniDSP

Table 107. Page 4 Registers (continued)

REGISTER NUMBER	RESET VALUE	REGISTER NAME
109	0000 0000	Coefficient N0(7:0) for Right ADC Biquad D or Coefficient FIR15(7:0) for ADC FIR Filter or Coefficient C54(7:0) of ADC miniDSP
110	0000 0000	Coefficient N1(15:8) for Right ADC Biquad D or Coefficient FIR16(15:8) for ADC FIR Filter or Coefficient C55(15:8) of ADC miniDSP
111	0000 0000	Coefficient N1(7:0) for Right ADC Biquad D or Coefficient FIR16(7:0) for ADC FIR Filter or Coefficient C55(7:0) of ADC miniDSP
112	0000 0000	Coefficient N2(15:8) for Right ADC Biquad D or Coefficient FIR17(15:8) for ADC FIR Filter or Coefficient C56(15:8) of ADC miniDSP
113	0000 0000	Coefficient N2(7:0) for Right ADC Biquad D or Coefficient FIR17(7:0) for ADC FIR Filter or Coefficient C56(7:0) of ADC miniDSP
114	0000 0000	Coefficient D1(15:8) for Right ADC Biquad D or Coefficient FIR18(15:8) for ADC FIR Filter or Coefficient C57(15:8) of ADC miniDSP
115	0000 0000	Coefficient D1(7:0) for Right ADC Biquad D or Coefficient FIR18(7:0) for ADC FIR Filter or Coefficient C57(7:0) of ADC miniDSP
116	0000 0000	Coefficient D2(15:8) for Right ADC Biquad D or Coefficient FIR19(15:8) for ADC FIR Filter or Coefficient C58(15:8) of ADC miniDSP
117	0000 0000	Coefficient D2(7:0) for Right ADC Biquad D or Coefficient FIR19(7:0) for ADC FIR Filter or Coefficient C58(7:0) of ADC miniDSP
118	0000 0000	Coefficient N0(15:8) for Right ADC Biquad E or Coefficient FIR20(15:8) for ADC FIR Filter or Coefficient C59(15:8) of ADC miniDSP
119	0000 0000	Coefficient N0(7:0) for Right ADC Biquad E or Coefficient FIR20(7:0) for ADC FIR Filter or Coefficient C59(7:0) of ADC miniDSP
120	0000 0000	Coefficient N1(15:8) for Right ADC Biquad E or Coefficient FIR21(15:8) for ADC FIR Filter or Coefficient C60(15:8) of ADC miniDSP
121	0000 0000	Coefficient N1(7:0) for Right ADC Biquad E or Coefficient FIR21(7:0) for ADC FIR Filter or Coefficient C60(7:0) of ADC miniDSP
122	0000 0000	Coefficient N2(15:8) for Right ADC Biquad E or Coefficient FIR22(15:8) for ADC FIR Filter or Coefficient C61(15:8) of ADC miniDSP
123	0000 0000	Coefficient N2(7:0) for Right ADC Biquad E or Coefficient FIR22(7:0) for ADC FIR Filter or Coefficient C61(7:0) of ADC miniDSP
124	0000 0000	Coefficient D1(15:8) for Right ADC Biquad E or Coefficient FIR23(15:8) for ADC FIR Filter or Coefficient C62(15:8) of ADC miniDSP
125	0000 0000	Coefficient D1(7:0) for Right ADC Biquad E or Coefficient FIR23(7:0) for ADC FIR Filter or Coefficient C62(7:0) of ADC miniDSP
126	0000 0000	Coefficient D2(15:8) for Right ADC Biquad E or Coefficient FIR24(15:8) for ADC FIR Filter or Coefficient C63(15:8) of ADC miniDSP
127	0000 0000	Coefficient D2(7:0) for Right ADC Biquad E or Coefficient FIR24(7:0) for ADC FIR Filter or Coefficient C63(7:0) of ADC miniDSP

10.6.5 Control Registers, Page 5: ADC Programmable Coefficients RAM (65:127)

Page 5 / Register 0 is the page control register as described below.

Table 108. Page 5 / Register 0: Page Control Register⁽¹⁾

BIT	READ/ WRITE	RESET VALUE	DESCRIPTION
D7–D0	R/W	0000 0000	0000 0000: Page 0 selected 0000 0001: Page 1 selected ... 1111 1110: Page 254 selected (reserved) 1111 1111: Page 255 selected (reserved)

(1) Valid pages are 0, 1, 4, 5, 32-47. All other pages are reserved (do not access).

Table 109 is a list of the page 5 registers, excepting the previously described register 0.

Table 109. Page 5 Registers

REGISTER NUMBER	RESET VALUE	REGISTER NAME
1	XXXX XXXX	Reserved. Do not write to this register.
2	0000 0000	Coefficient C65(15:8) of ADC miniDSP
3	0000 0000	Coefficient C65(7:0) of ADC miniDSP
4	0000 0000	Coefficient C66(15:8) of ADC miniDSP
5	0000 0000	Coefficient C66(7:0) of ADC miniDSP
6	0000 0000	Coefficient C67(15:8) of ADC miniDSP
7	0000 0000	Coefficient C67(7:0) of ADC miniDSP
8	0000 0000	Coefficient C68(15:8) of ADC miniDSP
9	0000 0000	Coefficient C68(7:0) of ADC miniDSP
10	0000 0000	Coefficient C69(15:8) of ADC miniDSP
11	0000 0000	Coefficient C69(7:0) of ADC miniDSP
12	0000 0000	Coefficient C70(15:8) of ADC miniDSP
13	0000 0000	Coefficient C70(7:0) of ADC miniDSP
14	0000 0000	Coefficient C71(15:8) of ADC miniDSP
15	0000 0000	Coefficient C71(7:0) of ADC miniDSP
16	0000 0000	Coefficient C72(15:8) of ADC miniDSP
17	0000 0000	Coefficient C72(7:0) of ADC miniDSP
18	0000 0000	Coefficient C73(15:8) of ADC miniDSP
19	0000 0000	Coefficient C73(7:0) of ADC miniDSP
20	0000 0000	Coefficient C74(15:8) of ADC miniDSP
21	0000 0000	Coefficient C74(7:0) of ADC miniDSP
22	0000 0000	Coefficient C75(15:8) of ADC miniDSP
23	0000 0000	Coefficient C75(7:0) of ADC miniDSP
24	0000 0000	Coefficient C76(15:8) of ADC miniDSP
25	0000 0000	Coefficient C76(7:0) of ADC miniDSP
26	0000 0000	Coefficient C77(15:8) of ADC miniDSP
27	0000 0000	Coefficient C77(7:0) of ADC miniDSP
28	0000 0000	Coefficient C78(15:8) of ADC miniDSP
29	0000 0000	Coefficient C78(7:0) of ADC miniDSP
30	0000 0000	Coefficient C79(15:8) of ADC miniDSP
31	0000 0000	Coefficient C79(7:0) of ADC miniDSP
32	0000 0000	Coefficient C80(15:8) of ADC miniDSP
33	0000 0000	Coefficient C80(7:0) of ADC miniDSP
34	0000 0000	Coefficient C81(15:8) of ADC miniDSP
35	0000 0000	Coefficient C81(7:0) of ADC miniDSP
36	0000 0000	Coefficient C82(15:8) of ADC miniDSP
37	0000 0000	Coefficient C82(7:0) of ADC miniDSP
38	0000 0000	Coefficient C83(15:8) of ADC miniDSP
39	0000 0000	Coefficient C83(7:0) of ADC miniDSP
40	0000 0000	Coefficient C84(15:8) of ADC miniDSP
41	0000 0000	Coefficient C84(7:0) of ADC miniDSP
42	0000 0000	Coefficient C85(15:8) of ADC miniDSP
43	0000 0000	Coefficient C85(7:0) of ADC miniDSP
44	0000 0000	Coefficient C86(15:8) of ADC miniDSP
45	0000 0000	Coefficient C86(7:0) of ADC miniDSP

Table 109. Page 5 Registers (continued)

REGISTER NUMBER	RESET VALUE	REGISTER NAME
46	0000 0000	Coefficient C87(15:8) of ADC miniDSP
47	0000 0000	Coefficient C87(7:0) of ADC miniDSP
48	0000 0000	Coefficient C88(15:8) of ADC miniDSP
49	0000 0000	Coefficient C88(7:0) of ADC miniDSP
50	0000 0000	Coefficient C89(15:8) of ADC miniDSP
51	0000 0000	Coefficient C89(7:0) of ADC miniDSP
52	0000 0000	Coefficient C90(15:8) of ADC miniDSP
53	0000 0000	Coefficient C90(7:0) of ADC miniDSP
54	0000 0000	Coefficient C91(15:8) of ADC miniDSP
55	0000 0000	Coefficient C91(7:0) of ADC miniDSP
56	0000 0000	Coefficient C92(15:8) of ADC miniDSP
57	0000 0000	Coefficient C92(7:0) of ADC miniDSP
58	0000 0000	Coefficient C93(15:8) of ADC miniDSP
59	0000 0000	Coefficient C93(7:0) of ADC miniDSP
60	0000 0000	Coefficient C94(15:8) of ADC miniDSP
61	0000 0000	Coefficient C94(7:0) of ADC miniDSP
62	0000 0000	Coefficient C95(15:8) of ADC miniDSP
63	0000 0000	Coefficient C95(7:0) of ADC miniDSP
64	0000 0000	Coefficient C96(15:8) of ADC miniDSP
65	0000 0000	Coefficient C96(7:0) of ADC miniDSP
66	0000 0000	Coefficient C97(15:8) of ADC miniDSP
67	0000 0000	Coefficient C97(7:0) of ADC miniDSP
68	0000 0000	Coefficient C98(15:8) of ADC miniDSP
69	0000 0000	Coefficient C98(7:0) of ADC miniDSP
70	0000 0000	Coefficient C99(15:8) of ADC miniDSP
71	0000 0000	Coefficient C99(7:0) of ADC miniDSP
72	0000 0000	Coefficient C100(15:8) of ADC miniDSP
73	0000 0000	Coefficient C100(7:0) of ADC miniDSP
74	0000 0000	Coefficient C101(15:8) of ADC miniDSP
75	0000 0000	Coefficient C101(7:0) of ADC miniDSP
76	0000 0000	Coefficient C102(15:8) of ADC miniDSP
77	0000 0000	Coefficient C102(7:0) of ADC miniDSP
78	0000 0000	Coefficient C103(15:8) of ADC miniDSP
79	0000 0000	Coefficient C103(7:0) of ADC miniDSP
80	0000 0000	Coefficient C104(15:8) of ADC miniDSP
81	0000 0000	Coefficient C104(7:0) of ADC miniDSP
82	0000 0000	Coefficient C105(15:8) of ADC miniDSP
83	0000 0000	Coefficient C105(7:0) of ADC miniDSP
84	0000 0000	Coefficient C106(15:8) of ADC miniDSP
85	0000 0000	Coefficient C106(7:0) of ADC miniDSP
86	0000 0000	Coefficient C107(15:8) of ADC miniDSP
87	0000 0000	Coefficient C107(7:0) of ADC miniDSP
88	0000 0000	Coefficient C108(15:8) of ADC miniDSP
89	0000 0000	Coefficient C108(7:0) of ADC miniDSP
90	0000 0000	Coefficient C109(15:8) of ADC miniDSP
91	0000 0000	Coefficient C109(7:0) of ADC miniDSP
92	0000 0000	Coefficient C110(15:8) of ADC miniDSP

Table 109. Page 5 Registers (continued)

REGISTER NUMBER	RESET VALUE	REGISTER NAME
93	0000 0000	Coefficient C110(7:0) of ADC miniDSP
94	0000 0000	Coefficient C111(15:8) of ADC miniDSP
95	0000 0000	Coefficient C111(7:0) of ADC miniDSP
96	0000 0000	Coefficient C112(15:8) of ADC miniDSP
97	0000 0000	Coefficient C112(7:0) of ADC miniDSP
98	0000 0000	Coefficient C113(15:8) of ADC miniDSP
99	0000 0000	Coefficient C113(7:0) of ADC miniDSP
100	0000 0000	Coefficient C114(15:8) of ADC miniDSP
101	0000 0000	Coefficient C114(7:0) of ADC miniDSP
102	0000 0000	Coefficient C115(15:8) of ADC miniDSP
103	0000 0000	Coefficient C115(7:0) of ADC miniDSP
104	0000 0000	Coefficient C117(15:8) of ADC miniDSP
105	0000 0000	Coefficient C117(7:0) of ADC miniDSP
106	0000 0000	Coefficient C117(15:8) of ADC miniDSP
107	0000 0000	Coefficient C117(7:0) of ADC miniDSP
108	0000 0000	Coefficient C118(15:8) of ADC miniDSP
109	0000 0000	Coefficient C118(7:0) of ADC miniDSP
110	0000 0000	Coefficient C119(15:8) of ADC miniDSP
111	0000 0000	Coefficient C119(7:0) of ADC miniDSP
112	0000 0000	Coefficient C120(15:8) of ADC miniDSP
113	0000 0000	Coefficient C120(7:0) of ADC miniDSP
114	0000 0000	Coefficient C121(15:8) of ADC miniDSP
115	0000 0000	Coefficient C121(7:0) of ADC miniDSP
116	0000 0000	Coefficient C122(15:8) of ADC miniDSP
117	0000 0000	Coefficient C122(7:0) of ADC miniDSP
118	0000 0000	Coefficient C123(15:8) of ADC miniDSP
119	0000 0000	Coefficient C123(7:0) of ADC miniDSP
120	0000 0000	Coefficient C124(15:8) of ADC miniDSP
121	0000 0000	Coefficient C124(7:0) of ADC miniDSP
122	0000 0000	Coefficient C125(15:8) of ADC miniDSP
123	0000 0000	Coefficient C125(7:0) of ADC miniDSP
124	0000 0000	Coefficient C126(15:8) of ADC miniDSP
125	0000 0000	Coefficient C126(7:0) of ADC miniDSP
126	0000 0000	Coefficient C127(15:8) of ADC miniDSP
127	0000 0000	Coefficient C127(7:0) of ADC miniDSP

10.6.6 Control Registers, Page 32: ADC DSP Engine Instruction RAM (0:31)

Control registers from Page 32 – Page 47 contain instruction RAM for the ADC miniDSP. There are 32 instructions / page and 16 pages so the TLV320ADC3101 miniDSP supports 512 instructions.

Table 110. Page 32 / Register 0: Page Control Register⁽¹⁾

BIT	READ/ WRITE	RESET VALUE	DESCRIPTION
D7–D0	R/W	0000 0000	0000 0000: Page 0 selected 0000 0001: Page 1 selected ... 1111 1110: Page 254 selected (reserved) 1111 1111: Page 255 selected (reserved)

(1) Valid pages are 0, 1, 4, 5, 32-47. All other pages are reserved (do not access).

Table 111. Page 32 / Register 1: Reserved

BIT	READ/ WRITE	RESET VALUE	DESCRIPTION
D7–D0	R/W	XXXX XXXX	Reserved. Write only the default value to this register

Table 112. Page 32 / Register 2: Inst_0(19:16)

BIT	READ/ WRITE	RESET VALUE	DESCRIPTION
D7–D4	R/W	XXXX	Reserved
D3–D0	R/W	XXXX	Instruction Inst_0(19:16) of ADC miniDSP

Table 113. Page 32 / Register 3: Inst_0(15:8)

BIT	READ/ WRITE	RESET VALUE	DESCRIPTION
D7–D0	R/W	XXXX XXXX	Instruction Inst_0(15:8) of ADC miniDSP

Table 114. Page 32 / Register 4: Inst_0(7:0)

BIT	READ/ WRITE	RESET VALUE	DESCRIPTION
D7–D0	R/W	XXXX XXXX	Instruction Inst_0(7:0) of ADC miniDSP

10.6.6.1 Page 32 / Register 5 Through Page 32 / Register 97

The remaining unreserved registers on page 32 are arranged in groups of three, with each group containing the bits of one instruction. The arrangement is the same as that of registers 2–4 for Instruction 0. Registers 5–7, 8–10, 11–13, ..., 95–97 contain instructions 1, 2, 3, ..., 31, respectively.

Table 115. Page 32 / Register 98 Through Page 32 / Register 127: Reserved

BIT	READ/ WRITE	RESET VALUE	DESCRIPTION
D7–D0	R/W	XXXX XXXX	Reserved. Write only the default value to this register

10.6.7 Control Registers, Pages 33–47: ADC DSP Engine Instruction RAM (32:63) Through (480:511)

The structuring of the registers within pages 33–43 is identical to that of page 32. Only the instruction numbers differ. The range of instructions within each page is listed in the following table.

PAGE	INSTRUCTIONS
33	32 to 63
34	64 to 95
35	96 to 127
36	128 to 159
37	160 to 191
38	192 to 223
39	224 to 255
40	256 to 287
41	288 to 319
42	320 to 351
43	352 to 383
44	384 to 415
45	416 to 447
46	448 to 479
47	480 to 511

11 Application and Implementation

NOTE

Information in the following applications sections is not part of the TI component specification, and TI does not warrant its accuracy or completeness. TI's customers are responsible for determining suitability of components for their purposes. Customers should validate and test their design implementation to confirm system functionality.

11.1 Application Information

This typical connection diagram highlights the required external components and system level connections for proper operation of the device in several popular use cases.

Each of these configurations can be realized using the Evaluation Modules (EVMs) for the device. These flexible modules allow full evaluation of the device in the most common modes of operation. Any design variation can be supported by TI through schematic and layout reviews. Visit <http://e2e.ti.com> for design assistance and join the audio amplifier discussion forum for additional information.

11.2 Typical Application

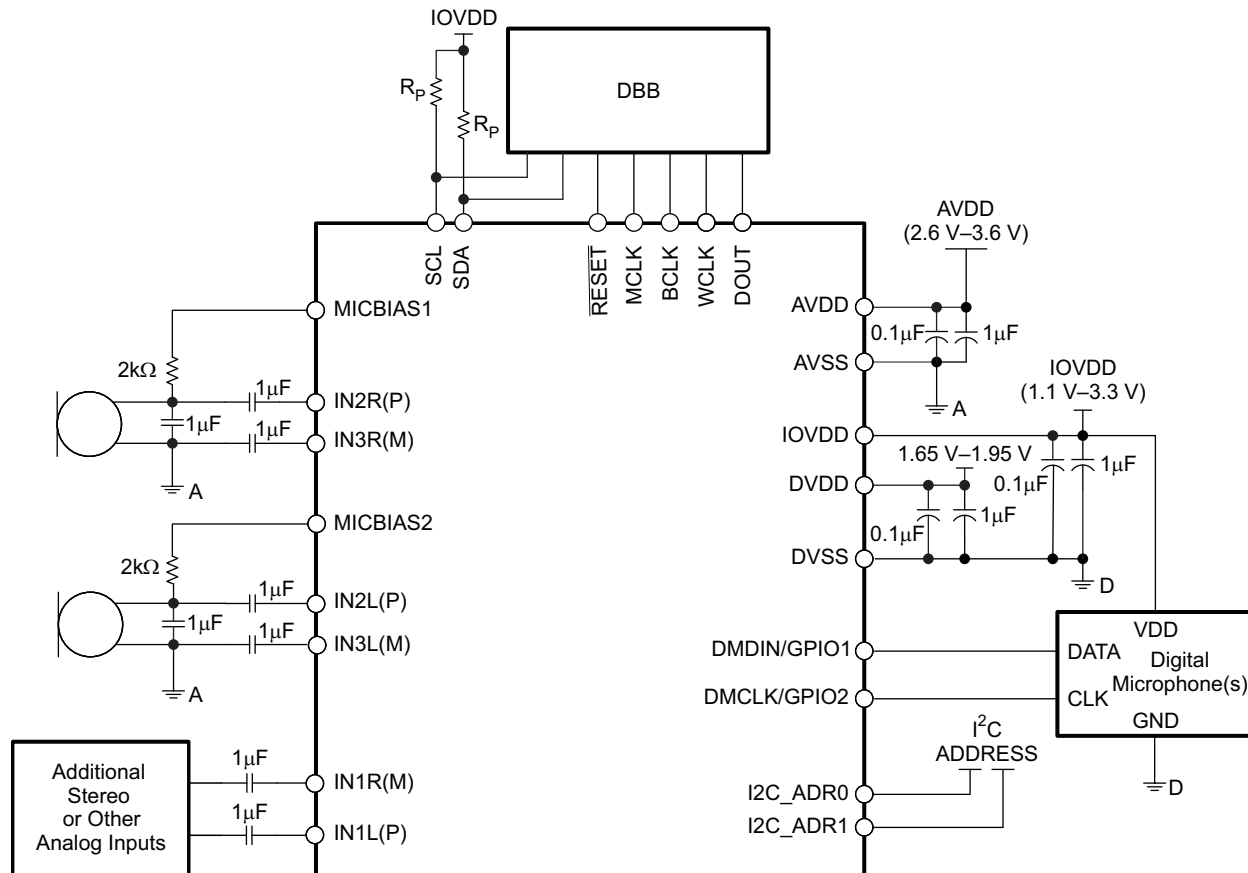

Figure 48. Typical Connections

Typical Application (continued)

11.2.1 Design Requirements

Table 116 lists the design parameters for this example.

Table 116. Design Parameters

KEY PARAMETER	SPECIFICATION/UNIT
AVDD	3.3 V
AVDD Supply Current	> 6 mA (PLL on, AGC off, miniDSP off, stereo record, fs = 48 kHz)
DVDD	1.8 V
DVDD Supply Current	> 4 mA (PLL on, AGC off, miniDSP off, stereo record, fs = 48 kHz)
IOVDD	1.8 V
Max. MICBIAS Current	4 mA (MICBIAS voltage 2.5 V)

11.2.2 Detailed Design Procedure

The following sections are intended to guide a user through the necessary steps to configure the TLV320ADC3101.

11.2.2.1 Step 1

The system clock source (master clock) and the targeted ADC sampling frequency must be identified.

Depending on the targeted performance, the decimation filter type (A, B or C) and AOSR value can be determined:

- Filter A must be used for 48 kHz high-performance operation; AOSR must be a multiple of 8.
- Filter B must be used for up to 96 kHz operations; AOSR must be a multiple of 4.
- Filter C must be used for up to 192 kHz operations; AOSR must be a multiple of 2.

In all cases, AOSR is limited in its range by the following condition:

$$2.8 \text{ MHz} < \text{AOSR} \times \text{ADC_fs} < 6.2 \text{ MHz} \quad (6)$$

Based on the identified filter type and the required signal-processing capabilities, the appropriate processing block can be determined from the list of available processing blocks (PRB_R1 to PRB_R18).

Based on the available master clock, the chosen AOSR and the targeted sampling rate, the clock divider values NADC and MADC can be determined. If necessary, the internal PLL can add a large degree of flexibility.

In summary, ADC_CLKIN (derived directly from the system clock source or from the internal PLL) divided by MADC, NADC and AOSR must be equal to the ADC sampling rate ADC_fs. The ADC_CLKIN clock signal is shared with the DAC clock-generation block.

$$\text{ADC_CLKIN} = \text{NADC} \times \text{MADC} \times \text{AOSR} \times \text{ADC_fs} \quad (7)$$

To a large degree, NADC and MADC can be chosen independently in the range of 1 to 128. In general, NADC must be as large as possible as long as the following condition can still be met:

$$\text{MADC} \times \text{AOSR} / 32 \geq \text{RC} \quad (8)$$

RC is a function of the chosen processing block and is listed in the Resource Class column of Table 5.

The common-mode voltage setting of the device is determined by the available analog power supply.

At this point, the following device-specific parameters are known: PRB_Rx, AOSR, NADC, MADC, input and output common-mode values. If the PLL is used, the PLL parameters P, J, D and R are determined as well.

11.2.2.2 Step 2

Setting up the device via register programming:

The following list gives a sequence of items that must be executed in the time between powering the device up and reading data from the device:

1. Define starting point:

- (a) Power up applicable external hardware power supplies.
 - (b) Set register page to 0.
 - (c) Initiate SW reset.
2. Program clock settings
- (a) Program PLL clock dividers P, J, D and R (if PLL is used).
 - (b) Power up PLL (if PLL is used).
 - (c) Program and power up NADC.
 - (d) Program and power up MADC.
 - (e) Program OSR value.
 - (f) Program I2S word length if required (for example, 20 bits).
 - (g) Program the processing block to be used.
3. Program analog blocks:
- (a) Set register page to 1
 - (b) Program MICBIAS if applicable
 - (c) Program MICPGA
 - (d) Program routing of inputs/common mode to ADC input.
 - (e) Unmute analog PGAs and set analog gain.
4. Program ADC:
- (a) Set register page to 0.
 - (b) Power up ADC channel.
 - (c) Unmute digital volume control and set gain.

11.2.2.3 Example Register Setup to Record Analog Data Through ADC to Digital Out

A typical EVM I²C register control script follows to show how to set up the TLV320ADC3001 in record mode with $f_s = 44.1$ kHz and MCLK = 11.2896 MHz.

```
# Key: w 30 XX YY ==> write to I2C address 0x30, to register 0xXX, data 0xYY
#           # ==> comment delimiter
#
# The following list gives an example sequence of items that must be executed in the time
# between powering the device up and reading data from the device. Note that there are
# other valid sequences depending on which features are used.
#
# ADC3101EVM Key Jumper Settings and Audio Connections:
# 1. Remove Jumpers W12 and W13
# 2. Insert Jumpers W4 and W5
# 3. Insert a 3.5mm stereo audio plug into J9 for
#     single-ended input IN1L(P) - left channel and
#     single-ended input IN1R(M) - right channel
#####
# 1. Define starting point:
#   (a) Power up applicable external hardware power supplies
#   (b) Set register page to 0
#
w 30 00 00
#   (c) Initiate SW Reset
#
w 30 01 01
#
# 2. Program Clock Settings
#   (a) Program PLL clock dividers P,J,D,R (if PLL is necessary)
#
# In EVM, the ADC3001 receives: MCLK = 11.2896 MHz,
# BCLK = 2.8224 MHz, WCLK = 44.1 kHz
#
# Since the sample rate is a multiple of the input MCLK then
# no PLL is needed thereby saving power. Use Default (Reset) Settings:
# ADC_CLKIN = MCLK, P=1, R=1, J=4, D=0000
w 30 04 00
w 30 05 11
w 30 06 04
w 30 07 00
w 30 08 00
#
#   (b) Power up PLL (if PLL is necessary) - Not Used in this Example
```

```

w 30 05 11
# (c) Program and power up NADC
#
# NADC = 1, divider powered on
w 30 12 81
#
# (d) Program and power up MADC
#
# MADC = 2, divider powered on
w 30 13 82
#
# (e) Program OSR value
#
# AOSR = 128 (default)
w 30 14 80
#
# (f) Program I2S word length as required (16, 20, 24, 32 bits)
#
# mode is i2s, wordlength is 16, slave mode (default)
w 30 1B 00
#
# (g) Program the processing block to be used
#
# PRB_P1
w 30 3d 01
#
# 3. Program Analog Blocks
# (a) Set register Page to 1
#
w 30 00 01
#
# (b) Program MICBIAS if applicable
#
# Not used (default)
w 30 33 00
#
# (c) Program MicPGA
#
# Left Analog PGA Seeting = 0dB
w 30 3b 00
#
# Right Analog PGA Seeting = 0dB
w 30 3c 00
#
# (d) Routing of inputs/common mode to ADC input
# (e) Unmute analog PGAs and set analog gain
#
# Left ADC Input selection for Left PGA = IN1L(P) as Single-Ended
w 30 34 fc
#
# Right ADC Input selection for Right PGA = IN1R(M) as Single-Ended
w 30 37 fc
#
# 4. Program ADC
#
# (a) Set register Page to 0
#
w 30 00 00
#
# (b) Power up ADC channel
#
# Power-up Left ADC and Right ADC
w 30 51 c2
#
# (c) Unmute digital volume control and set gain = 0 dB
#
# UNMUTE
w 30 52 00
#

```

11.2.2.4 MICBIAS

TLV320ADC3101 has a built-in bias voltage output for biasing of microphones. No intentional capacitors must be connected directly to the MICBIAS output for filtering.

11.2.2.5 Decoupling Capacitors

The TLV320ADC3101 requires adequate power supply decoupling to ensure that the noise and total harmonic distortion (THD) are low. A good ceramic capacitor, typically 0.1 μF , placed as close as possible to the device AVDD, IOVDD and DVDD lead works best. Placing this decoupling capacitor close to the TLV320ADC3101 is important for the performance of the converter. For filtering lower-frequency noise signals, a 1 μF or greater capacitor placed near the device would also help.

11.2.3 Application Curves

Table 117 lists the application curves in the [Typical Characteristics](#) section.

Table 117. Table of Graphs

GRAPH TITLE	FIGURE
Line Input to ADC FFT Plot	Figure 8
Input-Referred Noise vs. PGA Gain	Figure 9

12 Power Supply Recommendations

The power supplies are designed to operate from 2.6 V to 3.6 V for AVDD, from 1.65 V to 1.95 V for DVDD and from 1.1 V to 3.6 V for IOVDD. Any value out of these ranges must be avoided to ensure the correct behavior of the device. The power supplies must be well regulated. Placing a decoupling capacitor close to the TLV320ADC3101 improves the performance of the device. A low equivalent-series-resistance (ESR) ceramic capacitor with a value of 0.1 μF is a typical choice. If the TLV320ADC3101 is used in highly noise-sensitive circuits, it is recommended to add a small LC filter on the VDD connections.

13 Layout

13.1 Layout Guidelines

Each system design and PCB layout is unique. The layout must be carefully reviewed in the context of a specific PCB design. However, the following guidelines can optimize the TLV320ADC3101 performance:

The decoupling capacitors for the power supplies must be placed close to the device terminals. Figure 48 shows the recommended decoupling capacitors for the TLV320ADC3101.

For analog differential audio signals, they must be routed differentially on the PCB for better noise immunity. Avoid crossing digital and analog signals to avoid undesirable crosstalk.

Analog and digital grounds must be separated to prevent possible digital noise from affecting the analog performance of the board.

13.2 Layout Example

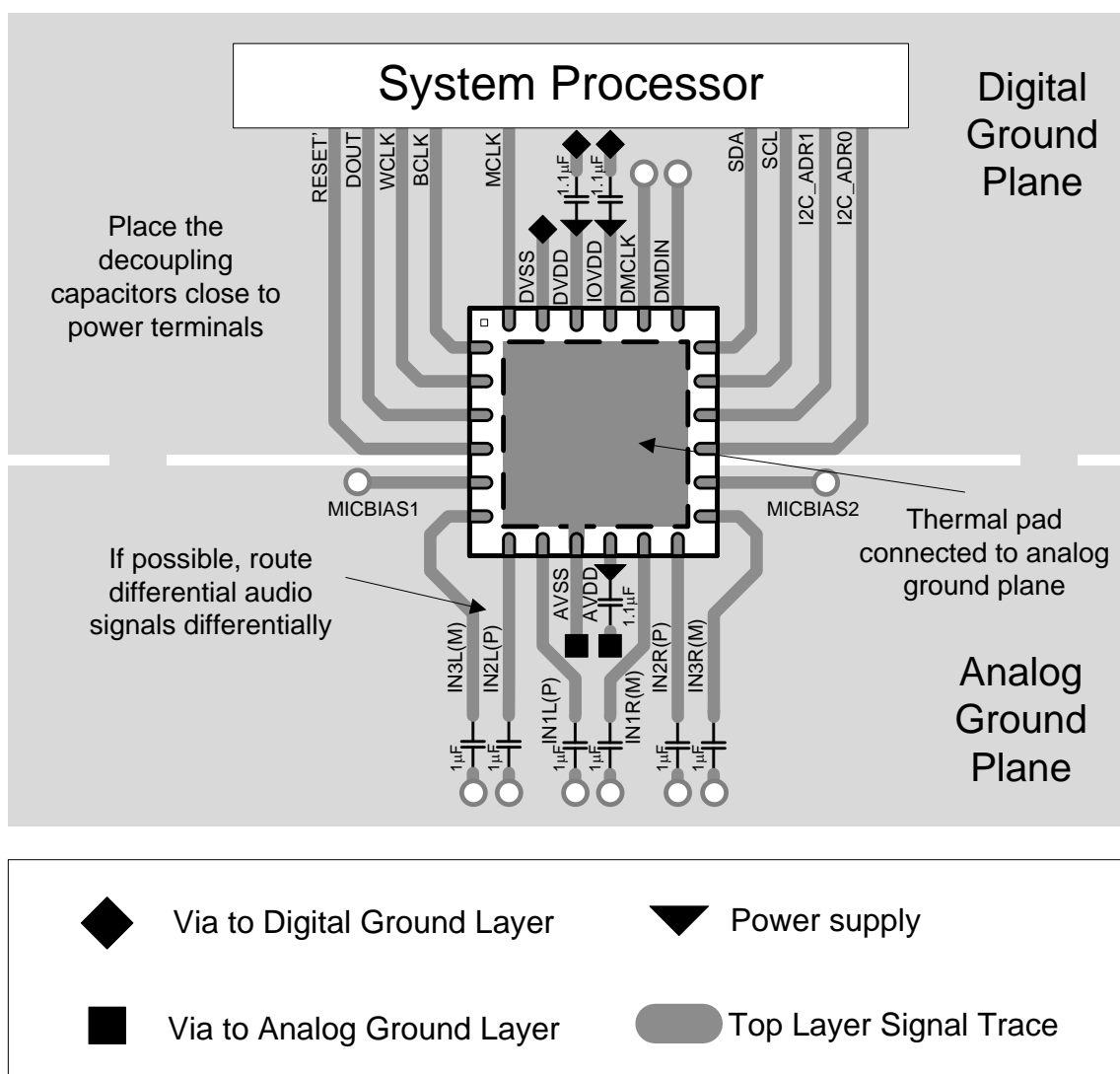

Figure 49. Layout Recommendation

14 Device and Documentation Support

14.1 Community Resources

The following links connect to TI community resources. Linked contents are provided "AS IS" by the respective contributors. They do not constitute TI specifications and do not necessarily reflect TI's views; see TI's [Terms of Use](#).

TI E2E™ Online Community *TI's Engineer-to-Engineer (E2E) Community*. Created to foster collaboration among engineers. At e2e.ti.com, you can ask questions, share knowledge, explore ideas and help solve problems with fellow engineers.

E2E Audio Amplifier Forum *TI's Engineer-to-Engineer (E2E) Community for Audio Amplifiers*. Created to foster collaboration among engineers. Ask questions and receive answers in real-time.

14.2 Trademarks

E2E is a trademark of Texas Instruments.
All other trademarks are the property of their respective owners.

14.3 Electrostatic Discharge Caution



These devices have limited built-in ESD protection. The leads should be shorted together or the device placed in conductive foam during storage or handling to prevent electrostatic damage to the MOS gates.

14.4 Glossary

[SLYZ022](#) — *TI Glossary*.

This glossary lists and explains terms, acronyms, and definitions.

15 Mechanical, Packaging, and Orderable Information

The following pages include mechanical, packaging, and orderable information. This information is the most current data available for the designated devices. This data is subject to change without notice and revision of this document. For browser-based versions of this data sheet, refer to the left-hand navigation.

PACKAGING INFORMATION

Orderable Device	Status (1)	Package Type	Package Drawing	Pins	Package Qty	Eco Plan (2)	Lead/Ball Finish (6)	MSL Peak Temp (3)	Op Temp (°C)	Device Marking (4/5)	Samples
TLV320ADC3101IRGER	ACTIVE	VQFN	RGE	24	3000	Green (RoHS & no Sb/Br)	CU NIPDAU	Level-2-260C-1 YEAR	-40 to 85	ADC 3101	Samples
TLV320ADC3101IRGET	ACTIVE	VQFN	RGE	24	250	Green (RoHS & no Sb/Br)	CU NIPDAU	Level-2-260C-1 YEAR	-40 to 85	ADC 3101	Samples

(1) The marketing status values are defined as follows:

ACTIVE: Product device recommended for new designs.

LIFEBUY: TI has announced that the device will be discontinued, and a lifetime-buy period is in effect.

NRND: Not recommended for new designs. Device is in production to support existing customers, but TI does not recommend using this part in a new design.

PREVIEW: Device has been announced but is not in production. Samples may or may not be available.

OBSELETE: TI has discontinued the production of the device.

(2) **RoHS:** TI defines "RoHS" to mean semiconductor products that are compliant with the current EU RoHS requirements for all 10 RoHS substances, including the requirement that RoHS substance do not exceed 0.1% by weight in homogeneous materials. Where designed to be soldered at high temperatures, "RoHS" products are suitable for use in specified lead-free processes. TI may reference these types of products as "Pb-Free".

RoHS Exempt: TI defines "RoHS Exempt" to mean products that contain lead but are compliant with EU RoHS pursuant to a specific EU RoHS exemption.

Green: TI defines "Green" to mean the content of Chlorine (Cl) and Bromine (Br) based flame retardants meet JS709B low halogen requirements of <=1000ppm threshold. Antimony trioxide based flame retardants must also meet the <=1000ppm threshold requirement.

(3) MSL, Peak Temp. - The Moisture Sensitivity Level rating according to the JEDEC industry standard classifications, and peak solder temperature.

(4) There may be additional marking, which relates to the logo, the lot trace code information, or the environmental category on the device.

(5) Multiple Device Markings will be inside parentheses. Only one Device Marking contained in parentheses and separated by a "~" will appear on a device. If a line is indented then it is a continuation of the previous line and the two combined represent the entire Device Marking for that device.

(6) Lead/Ball Finish - Orderable Devices may have multiple material finish options. Finish options are separated by a vertical ruled line. Lead/Ball Finish values may wrap to two lines if the finish value exceeds the maximum column width.

Important Information and Disclaimer:The information provided on this page represents TI's knowledge and belief as of the date that it is provided. TI bases its knowledge and belief on information provided by third parties, and makes no representation or warranty as to the accuracy of such information. Efforts are underway to better integrate information from third parties. TI has taken and continues to take reasonable steps to provide representative and accurate information but may not have conducted destructive testing or chemical analysis on incoming materials and chemicals. TI and TI suppliers consider certain information to be proprietary, and thus CAS numbers and other limited information may not be available for release.

In no event shall TI's liability arising out of such information exceed the total purchase price of the TI part(s) at issue in this document sold by TI to Customer on an annual basis.

OTHER QUALIFIED VERSIONS OF TLV320ADC3101 :

- Automotive: [TLV320ADC3101-Q1](#)

NOTE: Qualified Version Definitions:

- Automotive - Q100 devices qualified for high-reliability automotive applications targeting zero defects

TAPE AND REEL INFORMATION

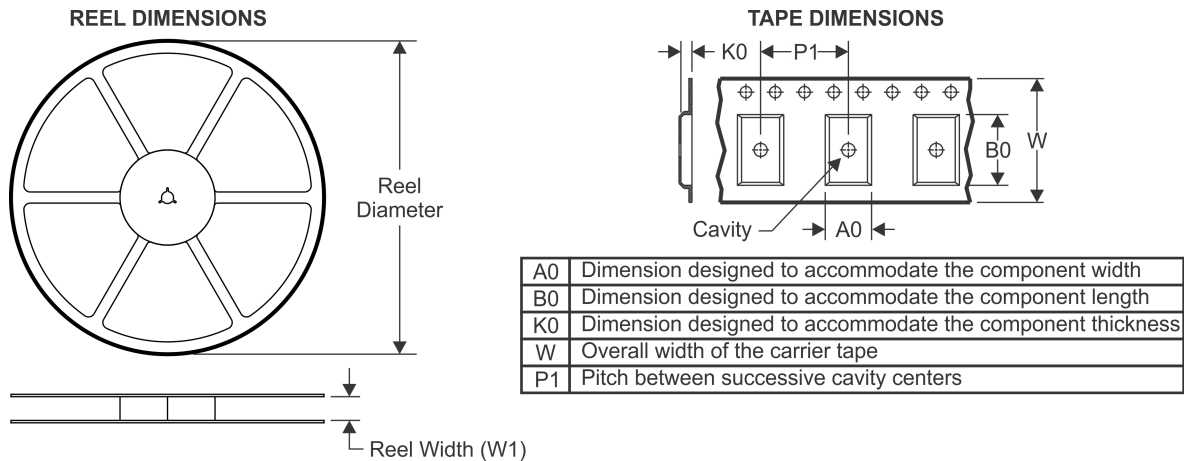

QUADRANT ASSIGNMENTS FOR PIN 1 ORIENTATION IN TAPE

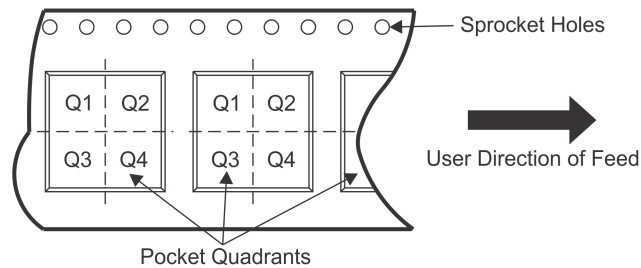

*All dimensions are nominal

Device	Package Type	Package Drawing	Pins	SPQ	Reel Diameter (mm)	Reel Width W1 (mm)	A0 (mm)	B0 (mm)	K0 (mm)	P1 (mm)	W (mm)	Pin1 Quadrant
TLV320ADC3101IRGER	VQFN	RGE	24	3000	330.0	12.4	4.25	4.25	1.15	8.0	12.0	Q2
TLV320ADC3101IRGET	VQFN	RGE	24	250	180.0	12.4	4.25	4.25	1.15	8.0	12.0	Q2

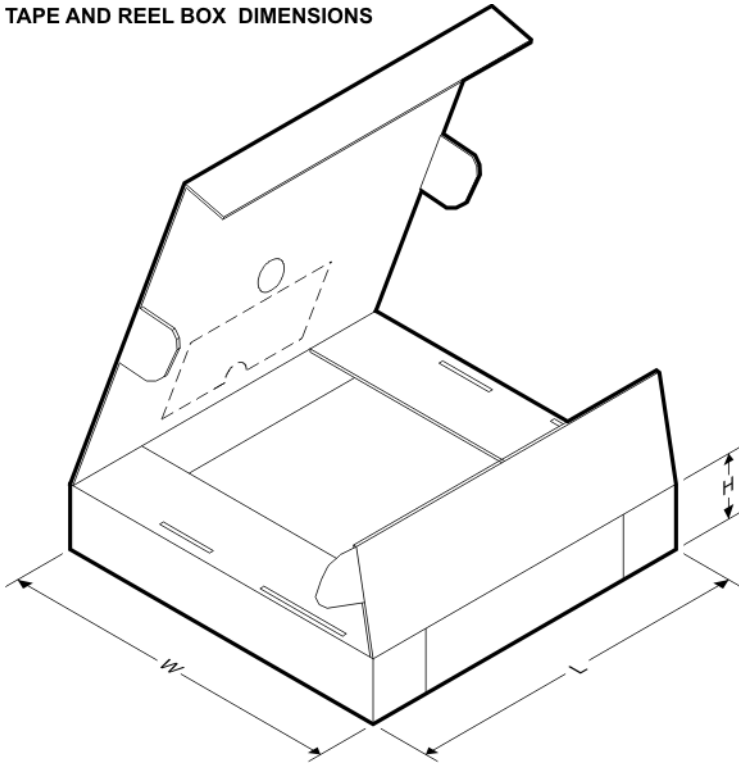
TAPE AND REEL BOX DIMENSIONS

*All dimensions are nominal

Device	Package Type	Package Drawing	Pins	SPQ	Length (mm)	Width (mm)	Height (mm)
TLV320ADC3101IRGER	VQFN	RGE	24	3000	367.0	367.0	35.0
TLV320ADC3101IRGET	VQFN	RGE	24	250	210.0	185.0	35.0

RGE 24

GENERIC PACKAGE VIEW

VQFN - 1 mm max height

PLASTIC QUAD FLATPACK - NO LEAD

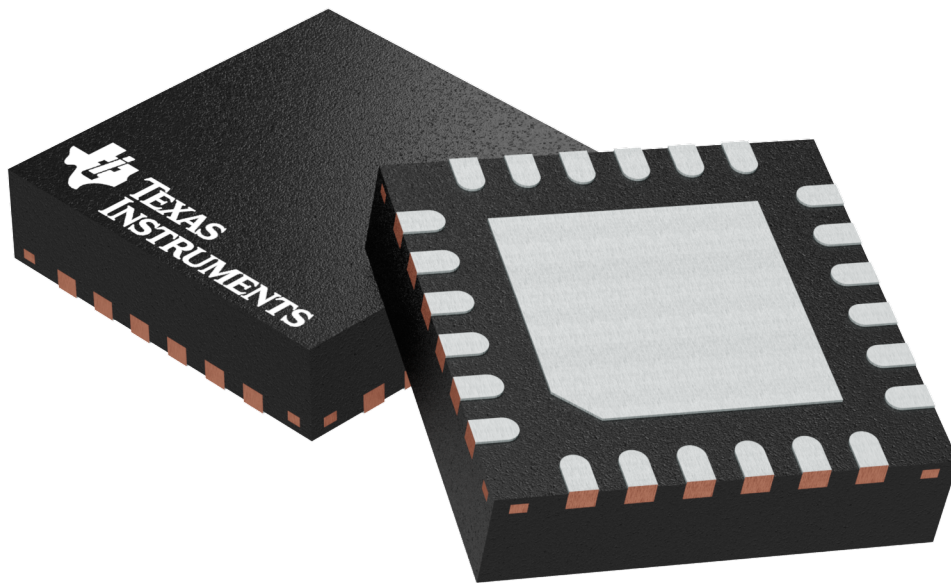

Images above are just a representation of the package family, actual package may vary.
Refer to the product data sheet for package details.

4204104/H

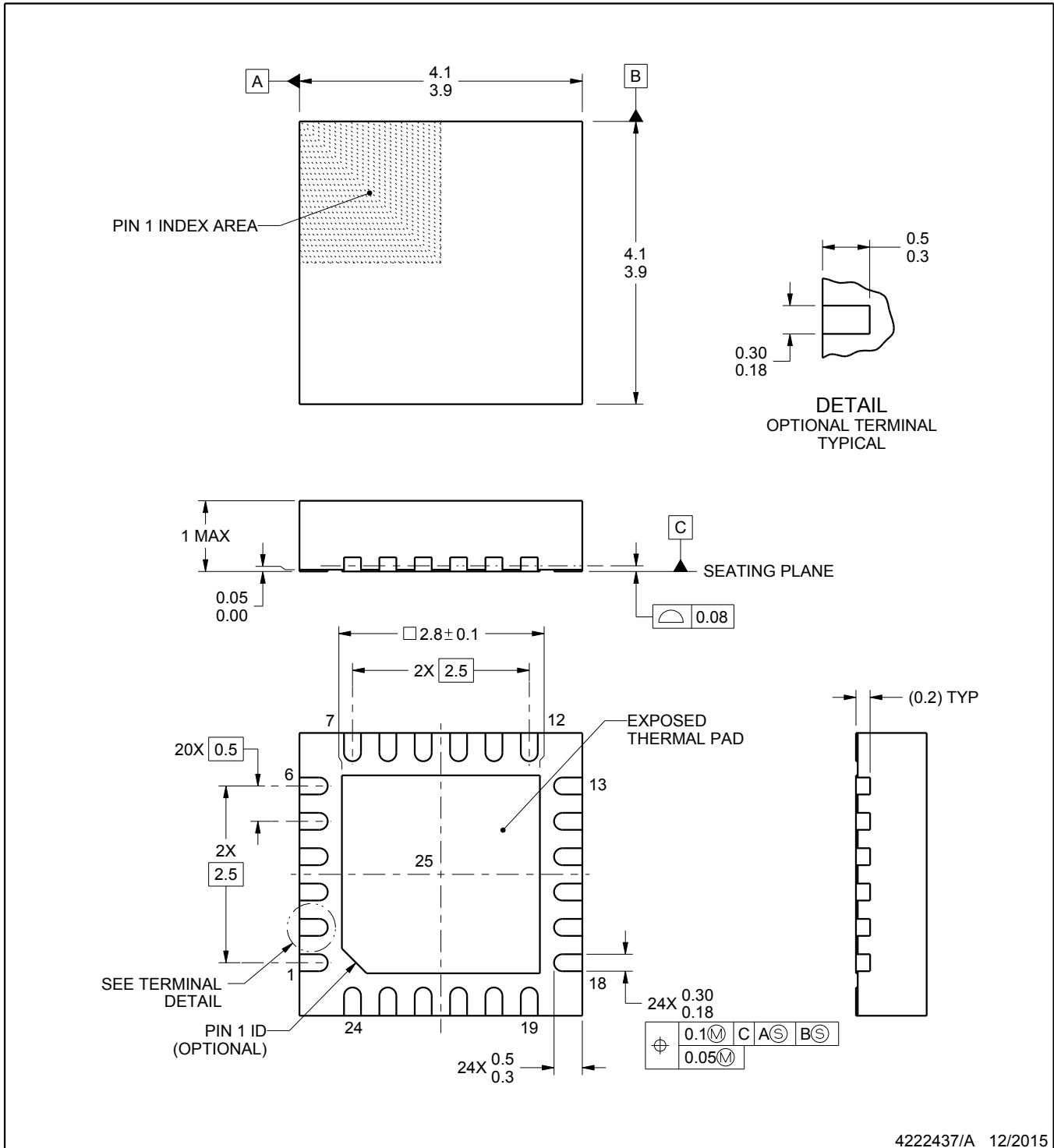
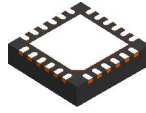

4222437/A 12/2015

NOTES:

1. All linear dimensions are in millimeters. Any dimensions in parenthesis are for reference only. Dimensioning and tolerancing per ASME Y14.5M.
2. This drawing is subject to change without notice.
3. The package thermal pad must be soldered to the printed circuit board for thermal and mechanical performance.
4. Reference JEDEC registration MO-220.

EXAMPLE BOARD LAYOUT

RGE0024F

VQFN - 1 mm max height

PLASTIC QUAD FLATPACK - NO LEAD

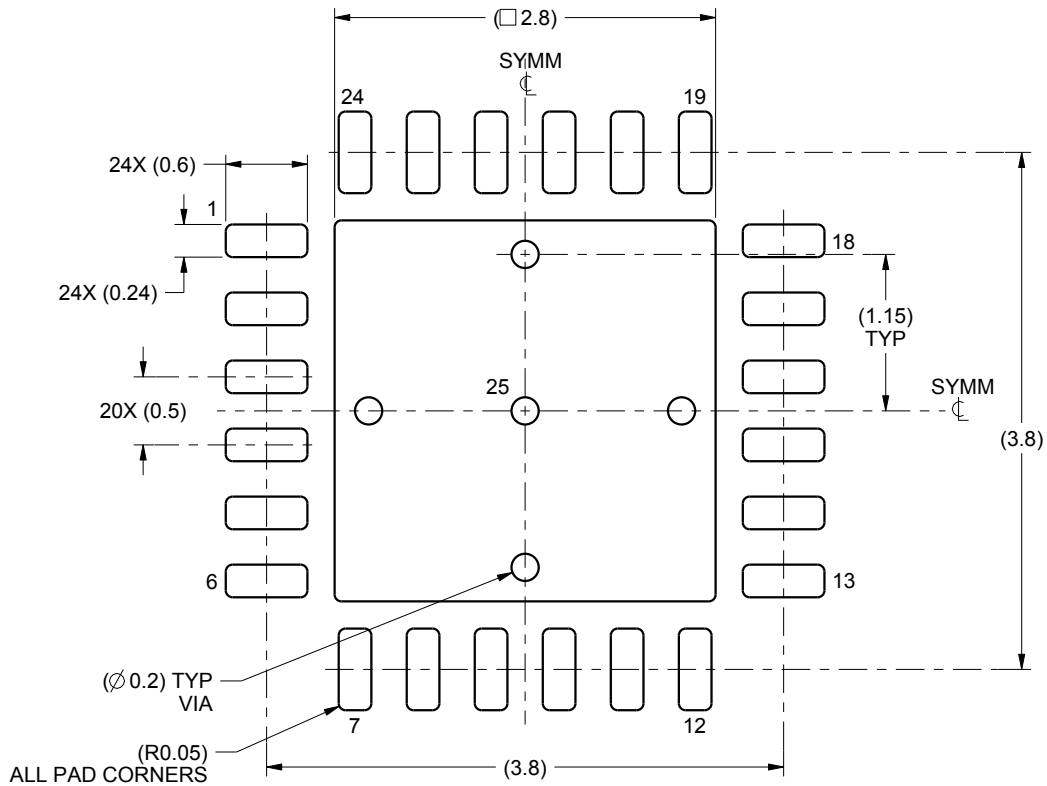

LAND PATTERN EXAMPLE
SCALE:18X

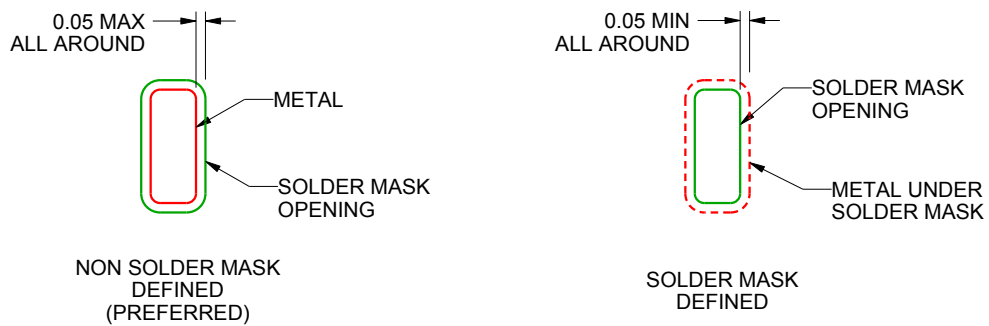

SOLDER MASK DETAILS

4222437/A 12/2015

NOTES: (continued)

5. This package is designed to be soldered to a thermal pad on the board. For more information, see Texas Instruments literature number SLUA271 (www.ti.com/lit/slua271).
6. Vias are optional depending on application, refer to device data sheet. If some or all are implemented, recommended via locations are shown.

EXAMPLE STENCIL DESIGN

RGE0024F

VQFN - 1 mm max height

PLASTIC QUAD FLATPACK - NO LEAD

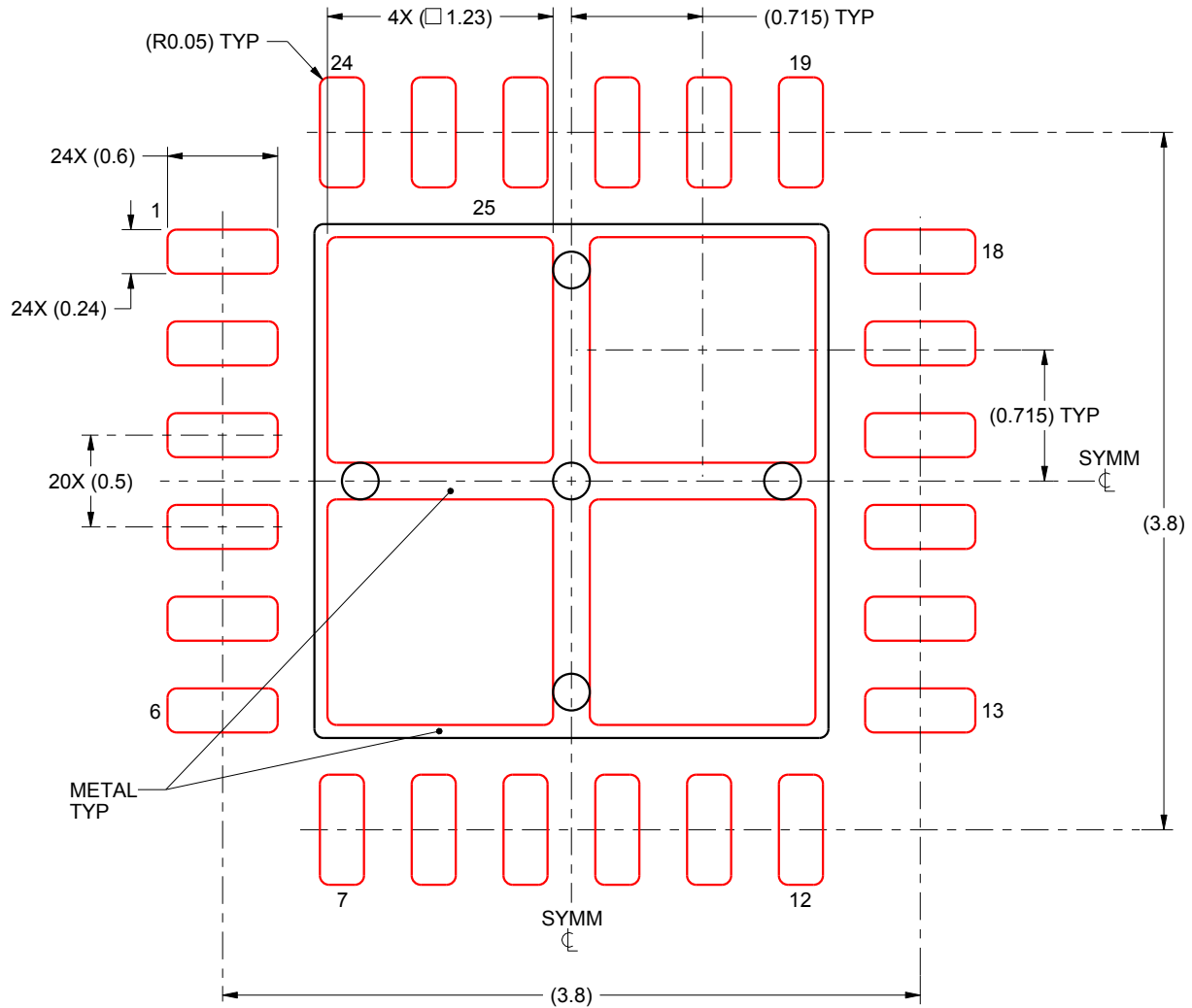

SOLDER PASTE EXAMPLE
BASED ON 0.125 mm THICK STENCIL

EXPOSED PAD 25:
77% PRINTED SOLDER COVERAGE BY AREA
SCALE:25X

4222437/A 12/2015

NOTES: (continued)

7. Laser cutting apertures with trapezoidal walls and rounded corners may offer better paste release. IPC-7525 may have alternate design recommendations.

IMPORTANT NOTICE

Texas Instruments Incorporated (TI) reserves the right to make corrections, enhancements, improvements and other changes to its semiconductor products and services per JESD46, latest issue, and to discontinue any product or service per JESD48, latest issue. Buyers should obtain the latest relevant information before placing orders and should verify that such information is current and complete.

TI's published terms of sale for semiconductor products (<http://www.ti.com/sc/docs/stdterms.htm>) apply to the sale of packaged integrated circuit products that TI has qualified and released to market. Additional terms may apply to the use or sale of other types of TI products and services.

Reproduction of significant portions of TI information in TI data sheets is permissible only if reproduction is without alteration and is accompanied by all associated warranties, conditions, limitations, and notices. TI is not responsible or liable for such reproduced documentation. Information of third parties may be subject to additional restrictions. Resale of TI products or services with statements different from or beyond the parameters stated by TI for that product or service voids all express and any implied warranties for the associated TI product or service and is an unfair and deceptive business practice. TI is not responsible or liable for any such statements.

Buyers and others who are developing systems that incorporate TI products (collectively, "Designers") understand and agree that Designers remain responsible for using their independent analysis, evaluation and judgment in designing their applications and that Designers have full and exclusive responsibility to assure the safety of Designers' applications and compliance of their applications (and of all TI products used in or for Designers' applications) with all applicable regulations, laws and other applicable requirements. Designer represents that, with respect to their applications, Designer has all the necessary expertise to create and implement safeguards that (1) anticipate dangerous consequences of failures, (2) monitor failures and their consequences, and (3) lessen the likelihood of failures that might cause harm and take appropriate actions. Designer agrees that prior to using or distributing any applications that include TI products, Designer will thoroughly test such applications and the functionality of such TI products as used in such applications.

TI's provision of technical, application or other design advice, quality characterization, reliability data or other services or information, including, but not limited to, reference designs and materials relating to evaluation modules, (collectively, "TI Resources") are intended to assist designers who are developing applications that incorporate TI products; by downloading, accessing or using TI Resources in any way, Designer (individually or, if Designer is acting on behalf of a company, Designer's company) agrees to use any particular TI Resource solely for this purpose and subject to the terms of this Notice.

TI's provision of TI Resources does not expand or otherwise alter TI's applicable published warranties or warranty disclaimers for TI products, and no additional obligations or liabilities arise from TI providing such TI Resources. TI reserves the right to make corrections, enhancements, improvements and other changes to its TI Resources. TI has not conducted any testing other than that specifically described in the published documentation for a particular TI Resource.

Designer is authorized to use, copy and modify any individual TI Resource only in connection with the development of applications that include the TI product(s) identified in such TI Resource. NO OTHER LICENSE, EXPRESS OR IMPLIED, BY ESTOPPEL OR OTHERWISE TO ANY OTHER TI INTELLECTUAL PROPERTY RIGHT, AND NO LICENSE TO ANY TECHNOLOGY OR INTELLECTUAL PROPERTY RIGHT OF TI OR ANY THIRD PARTY IS GRANTED HEREIN, including but not limited to any patent right, copyright, mask work right, or other intellectual property right relating to any combination, machine, or process in which TI products or services are used. Information regarding or referencing third-party products or services does not constitute a license to use such products or services, or a warranty or endorsement thereof. Use of TI Resources may require a license from a third party under the patents or other intellectual property of the third party, or a license from TI under the patents or other intellectual property of TI.

TI RESOURCES ARE PROVIDED "AS IS" AND WITH ALL FAULTS. TI DISCLAIMS ALL OTHER WARRANTIES OR REPRESENTATIONS, EXPRESS OR IMPLIED, REGARDING RESOURCES OR USE THEREOF, INCLUDING BUT NOT LIMITED TO ACCURACY OR COMPLETENESS, TITLE, ANY EPIDEMIC FAILURE WARRANTY AND ANY IMPLIED WARRANTIES OF MERCHANTABILITY, FITNESS FOR A PARTICULAR PURPOSE, AND NON-INFRINGEMENT OF ANY THIRD PARTY INTELLECTUAL PROPERTY RIGHTS. TI SHALL NOT BE LIABLE FOR AND SHALL NOT DEFEND OR INDEMNIFY DESIGNER AGAINST ANY CLAIM, INCLUDING BUT NOT LIMITED TO ANY INFRINGEMENT CLAIM THAT RELATES TO OR IS BASED ON ANY COMBINATION OF PRODUCTS EVEN IF DESCRIBED IN TI RESOURCES OR OTHERWISE. IN NO EVENT SHALL TI BE LIABLE FOR ANY ACTUAL, DIRECT, SPECIAL, COLLATERAL, INDIRECT, PUNITIVE, INCIDENTAL, CONSEQUENTIAL OR EXEMPLARY DAMAGES IN CONNECTION WITH OR ARISING OUT OF TI RESOURCES OR USE THEREOF, AND REGARDLESS OF WHETHER TI HAS BEEN ADVISED OF THE POSSIBILITY OF SUCH DAMAGES.

Unless TI has explicitly designated an individual product as meeting the requirements of a particular industry standard (e.g., ISO/TS 16949 and ISO 26262), TI is not responsible for any failure to meet such industry standard requirements.

Where TI specifically promotes products as facilitating functional safety or as compliant with industry functional safety standards, such products are intended to help enable customers to design and create their own applications that meet applicable functional safety standards and requirements. Using products in an application does not by itself establish any safety features in the application. Designers must ensure compliance with safety-related requirements and standards applicable to their applications. Designer may not use any TI products in life-critical medical equipment unless authorized officers of the parties have executed a special contract specifically governing such use. Life-critical medical equipment is medical equipment where failure of such equipment would cause serious bodily injury or death (e.g., life support, pacemakers, defibrillators, heart pumps, neurostimulators, and implantables). Such equipment includes, without limitation, all medical devices identified by the U.S. Food and Drug Administration as Class III devices and equivalent classifications outside the U.S.

TI may expressly designate certain products as completing a particular qualification (e.g., Q100, Military Grade, or Enhanced Product). Designers agree that it has the necessary expertise to select the product with the appropriate qualification designation for their applications and that proper product selection is at Designers' own risk. Designers are solely responsible for compliance with all legal and regulatory requirements in connection with such selection.

Designer will fully indemnify TI and its representatives against any damages, costs, losses, and/or liabilities arising out of Designer's non-compliance with the terms and provisions of this Notice.

Looking for pricing, stock, or lifecycle information?

Click below to explore more details on WIN SOURCE:

 [View TLV320ADC3101IRGET on WIN SOURCE](#)

 [Texas Instruments](#) Information

Optimize Your Supply Chain with WIN SOURCE Solutions

-  Global Sourcing Solution
-  Obsolete Management
-  Cost Control Management
-  Shortage Management
-  Alternative Solution
-  Excess Inventory Management