

TLP2601

Isolated Line Receiver
 Simplex / Multiplex Data Transmission
 Computer-Peripheral Interface
 Microprocessor System Interface
 Digital Isolation for A/D, D/A Conversion
 Direct Replacement for HCPL-2601

The TOSHIBA TLP2601 a photocoupler which combines a GaAlAs IRed as the emitter and an integrated high gain, high speed photodetector. The output of the detector circuit is an open collector, Schottky clamped transistor.

A Faraday shield integrated on the photodetector chip reduces the effects of capacitive coupling between the input LED emitter and the high gain stages of the detector. This provides an effective common mode transient immunity of 1000V/μs.

- Input current thresholds: $I_F = 5\text{mA}$ (max)
- Isolation voltage: 2500Vrms (min)
- Switching speed: 10MBd
- Common mode transient immunity: 1000V/μs (min)
- Guaranteed performance over temp.: 0°C to 70°C
- UL Recognized: UL1577, file No. E67349
- cUL approved :CSA Component Acceptance Service No. 5A, File No.E67349

Truth Table (positive logic)

Input	Enable	Output
H	H	L
L	H	H
H	L	H
L	L	H

Unit: mm

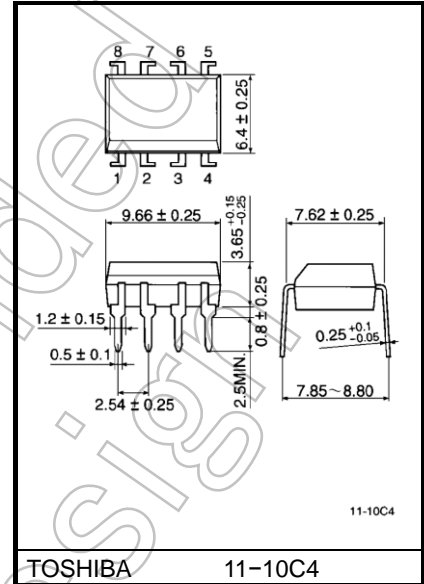

Weight: 0.54 g (typ.)

Pin Configuration (top view)

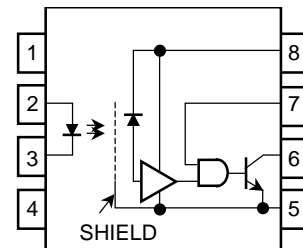

Schematic

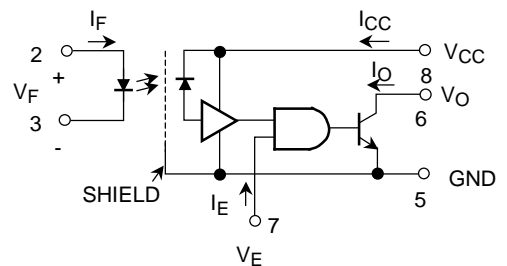

A 0.01 to 0.1μF bypass capacitor must be connected between pins 8 and 5 (see Note 1)

Start of commercial production
 1985-01

Recommended Operating Conditions

Characteristic	Symbol	Min	Typ.	Max	Unit
Input current, low level	I _{FL}	0	—	250	μA
Input current, high level	I _{FH}	6.3 (*)	—	20	mA
Supply voltage**, output	V _{CC}	4.5	—	5.5	V
High level enable voltage	V _{EH}	2.0	—	V _{CC}	V
Low level enable voltage	V _{EL}	0	—	0.8	V
Fan out (TTL load)	N	—	—	8	—
Operating temperature	T _{opr}	0	—	70	°C

Note: Recommended operating conditions are given as a design guideline to obtain expected performance of the device. Additionally, each item is an independent guideline respectively. In developing designs using this product, please confirm specified characteristics shown in this document.

(*) 6.3mA is a guard banded value which allows for at least 20% CTR degradation.
Initial input current threshold value is 5.0 mA or less.

**This item denotes operating ranges, not meaning of recommended operating conditions.

Absolute Maximum Ratings (no derating required)

Characteristic		Symbol	Rating	Unit
LED	Forward current	I _F	20	mA
	Reverse voltage	V _R	5	V
	Diode power dissipation	P _D	100	mW
	Diode power dissipation derating (T _a ≥ 70°C)	ΔP _D /°C	-1.8	mW/°C
	Junction Temperature	T _j	125	°C
Detector	Output current	I _O	25	mA
	Output voltage	V _O	-0.5 to 7	V
	Supply voltage (1 minute maximum)	V _{CC}	7	V
	Enable input voltage (not to exceed V _{CC} by more than 500mV)	V _E	5.5	V
	Output power dissipation	P _C	40	mW
	Output Power dissipation derating (T _a ≥ 70°C)	ΔP _C / °C	-0.7	mW / °C
	Junction Temperature	T _j	125	°C
	Operating temperature range	T _{opr}	-40 to 85	°C
Storage Temperature range	T _{stg}	-55 to 125	°C	
Lead Solder Temperature (10 s)	T _{sol}	260	°C	
Isolation voltage (R.H. ≤ 60%, AC 1minute)	(Note 10)	BV _S	2500	V _{rms}
			3540	V _{dc}

Note: Using continuously under heavy loads (e.g. the application of high temperature/current/voltage and the significant change in temperature, etc.) may cause this product to decrease in the reliability significantly even if the operating conditions (i.e. operating temperature/current/voltage, etc.) are within the absolute maximum ratings and the operating ranges.

Please design the appropriate reliability upon reviewing the Toshiba Semiconductor Reliability Handbook (“Handling Precautions”/“Derating Concept and Methods”) and individual reliability data (i.e. reliability test report and estimated failure rate, etc).

(**) 1.6mm below seating plane.

Electrical Characteristics (Ta = 0°C to 70°C unless otherwise noted)

Characteristic	Symbol	Test Condition	Min	Typ.	Max	Unit
High level output current	IOH	VCC = 5.5V, VO = 5.5V IF = 250μA, VE = 2.0V	—	1	250	μA
Low level output voltage	VOL	VCC = 5.5V, IF = 5mA VE = 2.0V, IOL(sinking) = 13mA	—	0.4	0.6	V
High level supply current	ICCH	VCC = 5.5V, IF = 0A, VE = 0.5V	—	7	15	mA
Low level supply current	ICCL	VCC = 5.5V, IF = 10mA, VE = 0.5V	—	12	19	mA
Low level enable current	I _{EL}	VCC = 5.5V, VE = 0.5V	—	-1.6	-2.0	mA
High level enable current	I _{EH}	VCC = 5.5V, VE = 2.0V	—	-1	—	mA
High level enable voltage	VEH	(Note 11)	2.0	—	—	V
Low level enable voltage	VEL	—	—	—	0.8	
Input forward voltage	VF	IF = 10mA, Ta = 25°C	—	1.65	1.75	V
Input reverse breakdown voltage	BVR	IR = 10μA, Ta = 25°C	5	—	—	V
Input capacitance	CIN	VF = 0 V, f = 1MHz	—	45	—	pF
Input diode temperature coefficient	ΔVF/ΔTA	IF = 10mA	—	-2.0	—	mV / °C
Input-output insulation leakage current	I _{I-O}	Relative humidity = 45% Ta=25°C, t = 5 second VI-O = 3000Vdc, (Note 10)	—	—	1	μA
Resistance (input-output)	R _{I-O}	VI-O = 500V, R.H. ≤ 60% (Note 10)	5×10 ¹⁰	10 ¹⁴	—	Ω
Capacitance (input-output)	C _{I-O}	f = 1MHz (Note 10)	—	0.6	—	pF

(**) All typ. values are at VCC = 5V, Ta = 25°C.

Switching Characteristics (Ta = 25°C, Vcc = 5 V)

Characteristic	Symbol	Test Circuit	Test Condition	Min	Typ.	Max	Unit
Propagation delay time to high output level	t _{pLH}	1	R _L = 350Ω, C _L = 15pF I _F = 7.5mA (Note 2), (Note 3), (Note 4)&(Note 5)	—	60	75	ns
Propagation delay time to low output level	t _{pHL}			—	60	75	ns
Output rise time (10–90%)	t _r			—	30	—	ns
Output fall time (90–10%)	t _f			—	30	—	ns
Propagation delay time of enable from V _{EH} to V _{EL}	t _{ELH}	2	R _L = 350Ω, C _L = 15pF I _F = 7.5mA V _{EH} = 3.0V V _{EL} = 0.5V (Note 6) & (Note 7)	—	25	—	ns
Propagation delay time of enable from V _{EL} to V _{EH}	t _{EHL}			—	25	—	ns
Common mode transient immunity at high output level	CM _H	3	V _{CM} = 400V R _L = 350Ω V _{O(min)} = 2V I _F = 0mA, (Note 9)	1000	10000	—	V/μs
Common mode transient immunity at low output level	CM _L			–1000	–10000	—	V/μs

Not Recommended for New Design

Test Circuit 1.

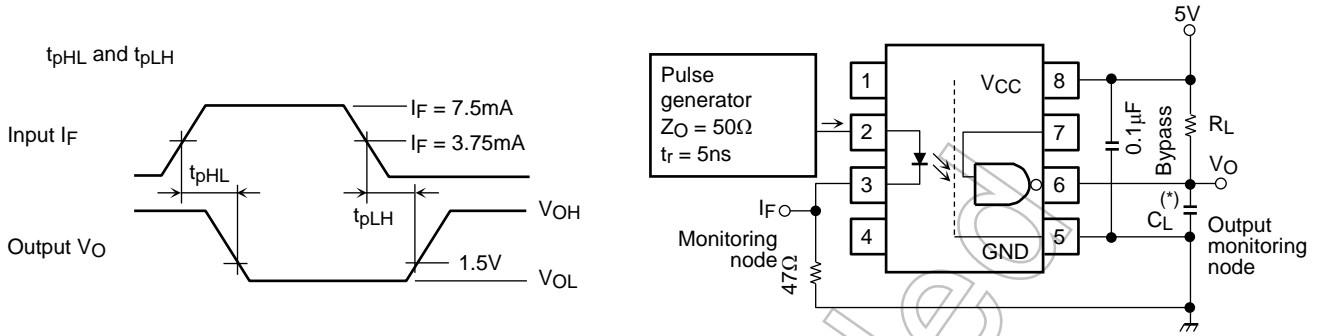

(*) C_L is approximately 15pF which includes probe and stray wiring capacitance.

Test Circuit 2.

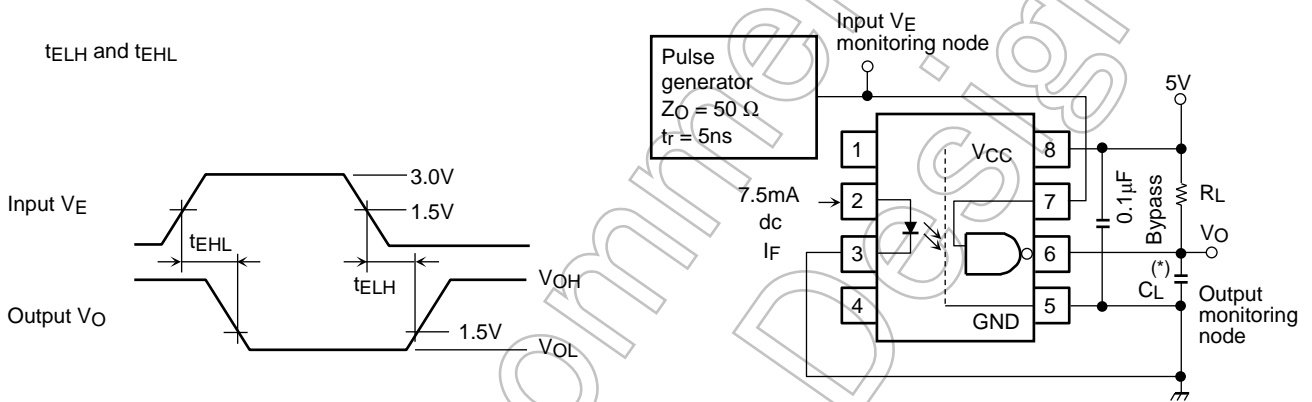

(*) C_L is approximately 15pF which includes probe and stray wiring capacitance.

Test Circuit 3.

Transient Immunity and Typical Waveforms.

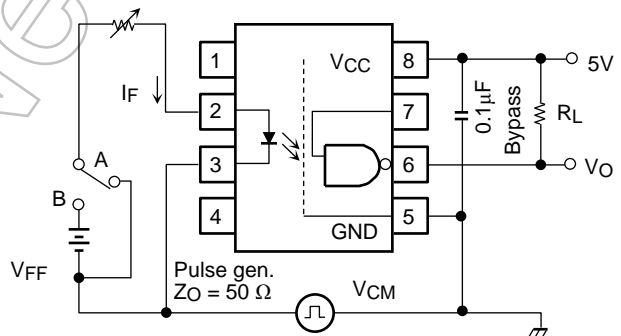
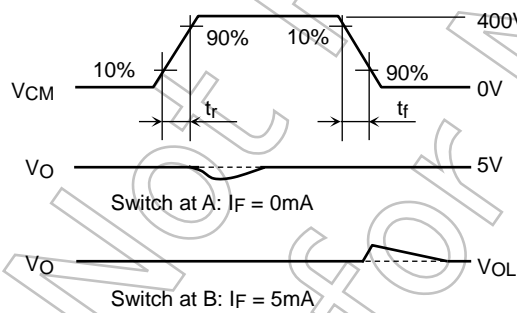

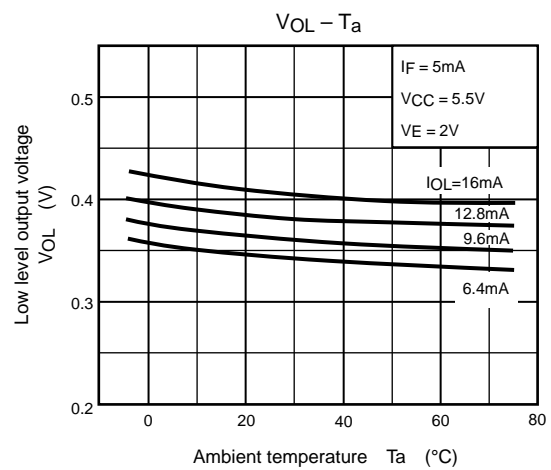
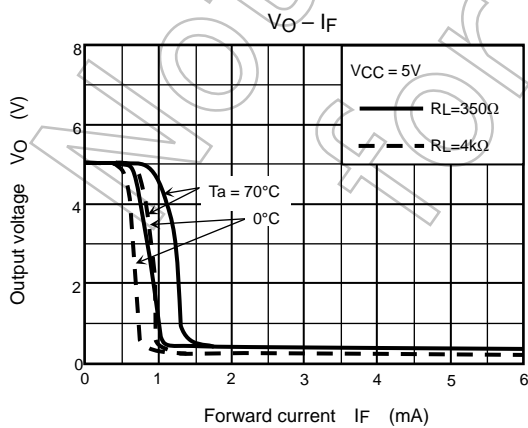
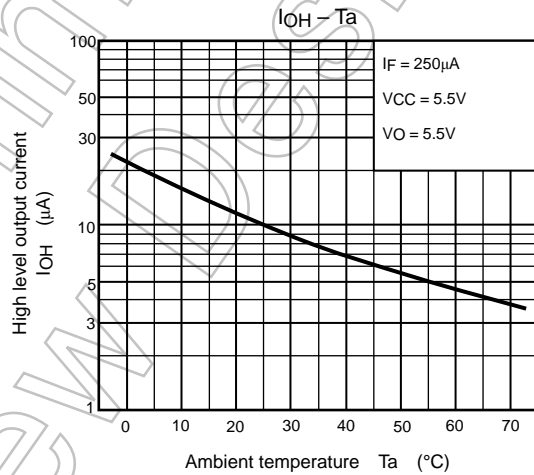
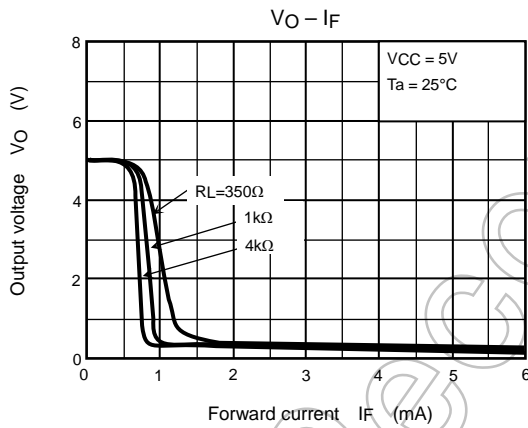
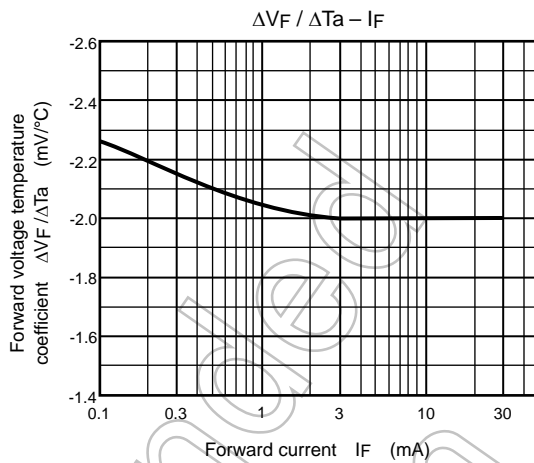
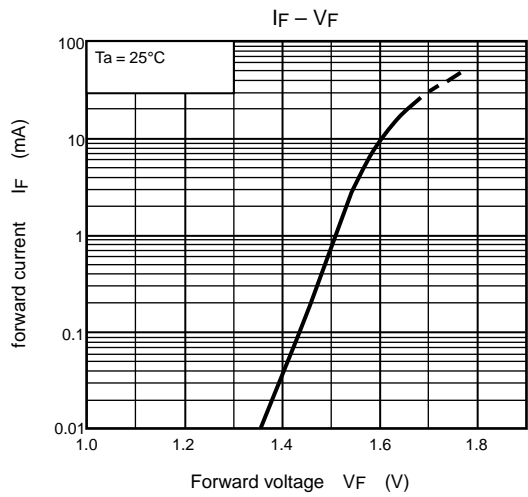

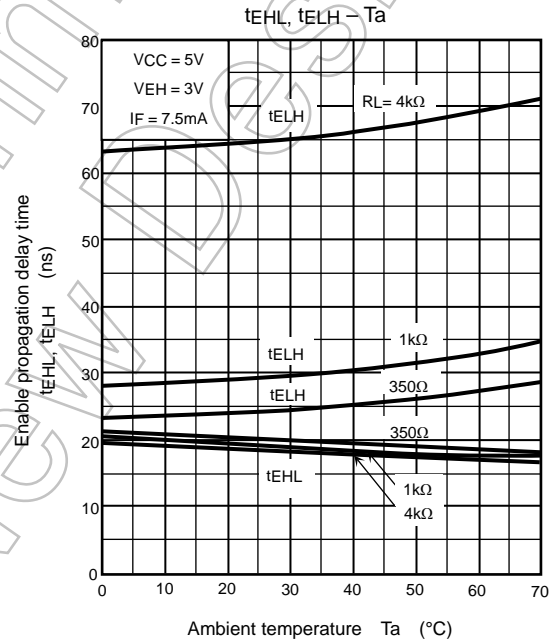
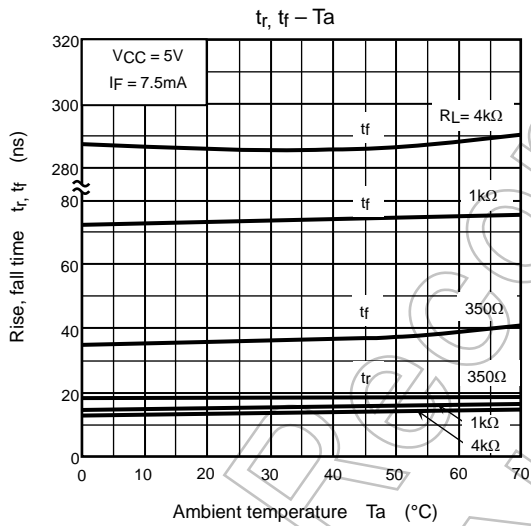
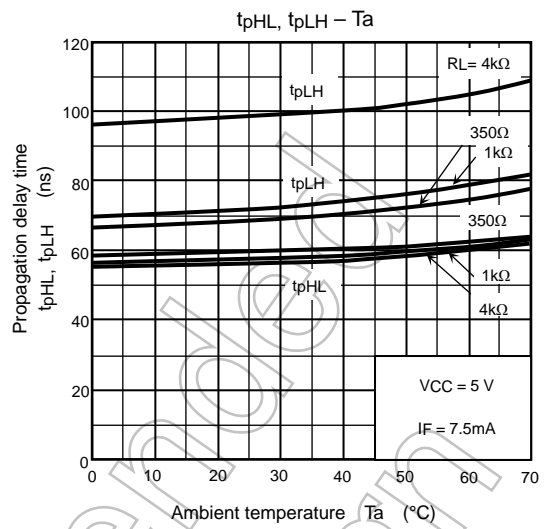
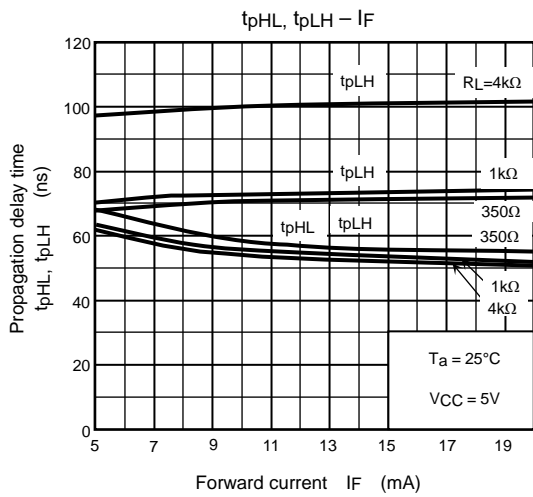

Notes

1. The VCC supply voltage to each TLP2601 isolator must be bypassed by a 0.1μF capacitor of larger. This can be either a ceramic or solid tantalum capacitor with good high frequency characteristic and should be connected as close as possible to the package VCC and GND pins of each device.
 2. t_{pHL} · Propagation delay is measured from the 3.75mA level on the low to high transition of the input current pulse to the 1.5V level on the high to low transition of the output voltage pulse.
 3. t_{pLH} · Propagation delay is measured from the 3.75mA level on the high to low transition of the input current pulse to the 1.5V level on the low to high transition of the output voltage pulse.
 4. t_f · Fall time is measured from the 10% to 90% levels of the high to low transition on the output pulse.
 5. t_r · Rise time is measured from the 90% to 10% levels of the low to high transition on the output pulse.
 6. t_{EHL} · Enable input propagation delay is measured from the 1.5V level on the low to high transition of the input voltage pulse to the 1.5V level on the high to low transition of the output voltage pulse.
 7. t_{ELH} · Enable input propagation delay is measured from the 1.5V level on the high to low transition of the input voltage pulse to the 1.5V level on the low to high transition of the output voltage pulse.
 8. CM_L · The maximum tolerable rate of fall of the common mode voltage to ensure the output will remain in the low output state (i.e. $V_{OUT} < 0.8V$).
Measured in volts per microsecond (V / μs).
 9. CM_H · The maximum tolerable rate of fall of the common mode voltage to ensure the output will remain in the high state (i.e. $V_{OUT} > 2.0V$).
Measured in volts per microsecond (V / μs).
Volts/microsecond can be translated to sinusoidal voltages:
- $$V / \mu s = \frac{(dv_{CM})}{dt}_{Max.} = f_{CM} V_{CM} \text{ (p.p.)}$$
- Example:
 $V_{CM} = 318V_{pp}$ when $f_{CM} = 1MHz$ using CM_L and $CM_H = 1000V / \mu s$ data sheet specified minimum.
10. · Device considered a two-terminal device: Pins 1, 2, 3 and 4 shorted together, and Pins 5, 6, 7 and 8 shorted together.
 11. Enable input · No pull up resistor required as the device has an internal pull up resistor.

RESTRICTIONS ON PRODUCT USE

Toshiba Corporation and its subsidiaries and affiliates are collectively referred to as "TOSHIBA". Hardware, software and systems described in this document are collectively referred to as "Product".

- TOSHIBA reserves the right to make changes to the information in this document and related Product without notice.
- This document and any information herein may not be reproduced without prior written permission from TOSHIBA. Even with TOSHIBA's written permission, reproduction is permissible only if reproduction is without alteration/omission.
- Though TOSHIBA works continually to improve Product's quality and reliability, Product can malfunction or fail. Customers are responsible for complying with safety standards and for providing adequate designs and safeguards for their hardware, software and systems which minimize risk and avoid situations in which a malfunction or failure of Product could cause loss of human life, bodily injury or damage to property, including data loss or corruption. Before customers use the Product, create designs including the Product, or incorporate the Product into their own applications, customers must also refer to and comply with (a) the latest versions of all relevant TOSHIBA information, including without limitation, this document, the specifications, the data sheets and application notes for Product and the precautions and conditions set forth in the "TOSHIBA Semiconductor Reliability Handbook" and (b) the instructions for the application with which the Product will be used with or for. Customers are solely responsible for all aspects of their own product design or applications, including but not limited to (a) determining the appropriateness of the use of this Product in such design or applications; (b) evaluating and determining the applicability of any information contained in this document, or in charts, diagrams, programs, algorithms, sample application circuits, or any other referenced documents; and (c) validating all operating parameters for such designs and applications. **TOSHIBA ASSUMES NO LIABILITY FOR CUSTOMERS' PRODUCT DESIGN OR APPLICATIONS.**
- **PRODUCT IS NEITHER INTENDED NOR WARRANTED FOR USE IN EQUIPMENTS OR SYSTEMS THAT REQUIRE EXTRAORDINARILY HIGH LEVELS OF QUALITY AND/OR RELIABILITY, AND/OR A MALFUNCTION OR FAILURE OF WHICH MAY CAUSE LOSS OF HUMAN LIFE, BODILY INJURY, SERIOUS PROPERTY DAMAGE AND/OR SERIOUS PUBLIC IMPACT ("UNINTENDED USE").** Except for specific applications as expressly stated in this document, Unintended Use includes, without limitation, equipment used in nuclear facilities, equipment used in the aerospace industry, medical equipment, equipment used for automobiles, trains, ships and other transportation, traffic signaling equipment, equipment used to control combustions or explosions, safety devices, elevators and escalators, devices related to electric power, and equipment used in finance-related fields. **IF YOU USE PRODUCT FOR UNINTENDED USE, TOSHIBA ASSUMES NO LIABILITY FOR PRODUCT.** For details, please contact your TOSHIBA sales representative.
- Do not disassemble, analyze, reverse-engineer, alter, modify, translate or copy Product, whether in whole or in part.
- Product shall not be used for or incorporated into any products or systems whose manufacture, use, or sale is prohibited under any applicable laws or regulations.
- The information contained herein is presented only as guidance for Product use. No responsibility is assumed by TOSHIBA for any infringement of patents or any other intellectual property rights of third parties that may result from the use of Product. No license to any intellectual property right is granted by this document, whether express or implied, by estoppel or otherwise.
- **ABSENT A WRITTEN SIGNED AGREEMENT, EXCEPT AS PROVIDED IN THE RELEVANT TERMS AND CONDITIONS OF SALE FOR PRODUCT, AND TO THE MAXIMUM EXTENT ALLOWABLE BY LAW, TOSHIBA (1) ASSUMES NO LIABILITY WHATSOEVER, INCLUDING WITHOUT LIMITATION, INDIRECT, CONSEQUENTIAL, SPECIAL, OR INCIDENTAL DAMAGES OR LOSS, INCLUDING WITHOUT LIMITATION, LOSS OF PROFITS, LOSS OF OPPORTUNITIES, BUSINESS INTERRUPTION AND LOSS OF DATA, AND (2) DISCLAIMS ANY AND ALL EXPRESS OR IMPLIED WARRANTIES AND CONDITIONS RELATED TO SALE, USE OF PRODUCT, OR INFORMATION, INCLUDING WARRANTIES OR CONDITIONS OF MERCHANTABILITY, FITNESS FOR A PARTICULAR PURPOSE, ACCURACY OF INFORMATION, OR NONINFRINGEMENT.**
- GaAs (Gallium Arsenide) is used in Product. GaAs is harmful to humans if consumed or absorbed, whether in the form of dust or vapor. Handle with care and do not break, cut, crush, grind, dissolve chemically or otherwise expose GaAs in Product.
- Do not use or otherwise make available Product or related software or technology for any military purposes, including without limitation, for the design, development, use, stockpiling or manufacturing of nuclear, chemical, or biological weapons or missile technology products (mass destruction weapons). Product and related software and technology may be controlled under the applicable export laws and regulations including, without limitation, the Japanese Foreign Exchange and Foreign Trade Law and the U.S. Export Administration Regulations. Export and re-export of Product or related software or technology are strictly prohibited except in compliance with all applicable export laws and regulations.
- Please contact your TOSHIBA sales representative for details as to environmental matters such as the RoHS compatibility of Product. Please use Product in compliance with all applicable laws and regulations that regulate the inclusion or use of controlled substances, including without limitation, the EU RoHS Directive. **TOSHIBA ASSUMES NO LIABILITY FOR DAMAGES OR LOSSES OCCURRING AS A RESULT OF NONCOMPLIANCE WITH APPLICABLE LAWS AND REGULATIONS.**

Looking for pricing, stock, or lifecycle information?

Click below to explore more details on WIN SOURCE:

- [View TLP2601\(TP1\) on WIN SOURCE](#)
- [Toshiba Semiconductor and Storage Information](#)

Optimize Your Supply Chain with WIN SOURCE Solutions

- ✓ Global Sourcing Solution
- ✓ Obsolete Management
- ✓ Cost Control Management
- ✓ Shortage Management
- ✓ Alternative Solution
- ✓ Excess Inventory Management