



# THE DATASHEET OF TLF4277E



# TLF4277

Low Drop Out Linear Voltage Regulator  
Integrated Current Monitor TLF4277EL

## Data Sheet

Rev. 1.02, 2011-07-05

Automotive Power

## Table of Contents

<b>1</b>	<b>Overview</b> .....	<b>3</b>
<b>2</b>	<b>Block Diagram</b> .....	<b>4</b>
<b>3</b>	<b>Pin Configuration</b> .....	<b>5</b>
3.1	Pin Assignment .....	5
3.2	Pin Definitions and Functions .....	5
<b>4</b>	<b>General Product Characteristics</b> .....	<b>6</b>
4.1	Absolute Maximum Ratings .....	6
4.2	Functional Range .....	7
4.3	Thermal Resistance .....	7
<b>5</b>	<b>Voltage Regulator</b> .....	<b>8</b>
5.1	Description Voltage Regulator .....	8
5.2	Electrical Characteristics Voltage Regulator .....	9
5.3	Application Information for the setting the variable output voltage .....	10
5.4	Typical Performance Characteristics Voltage Regulator .....	11
<b>6</b>	<b>Current Consumption</b> .....	<b>12</b>
6.1	Electrical Characteristics Current Consumption .....	12
6.2	Typical Performance Graphs Current Consumption .....	13
<b>7</b>	<b>Current and Protection Monitor Functions</b> .....	<b>14</b>
7.1	Functional Description Current and Protection Monitors .....	14
7.1.1	Linear Current Monitor .....	15
7.1.2	Adjustable Output Current Limitation .....	16
7.1.3	Overvoltage Detection .....	16
7.1.4	Thermal Shutdown Detection .....	16
7.2	Electrical Characteristics Current and Protection Monitor .....	17
<b>8</b>	<b>Enable Function</b> .....	<b>18</b>
8.1	Description Enable Function .....	18
8.2	Electrical Characteristics Enable Function .....	18
<b>9</b>	<b>Application Information</b> .....	<b>19</b>
9.1	Measurement Circuit .....	19
<b>10</b>	<b>Package Outlines</b> .....	<b>20</b>
<b>11</b>	<b>Revision History</b> .....	<b>21</b>



## 1 Overview

### Features

- Integrated Current Monitor
- Adjustable Current Limitation
- Adjustable Output Voltage
- Overvoltage Detection
- Output Current up to 200 mA
- Very Low Current Consumption
- Very Low Dropout Voltage
- Wide Input Voltage Range up to 40 V
- Reverse Polarity Protection
- Short Circuit Protected
- Overtemperature Shutdown
- Automotive Temperature Range  $-40\text{ °C} \leq T_j \leq 150\text{ °C}$
- Green Product (RoHS and WEEE compliant)
- AEC Qualified

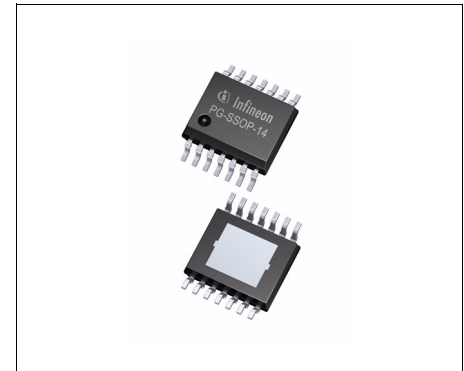

**PG-SSOP14 EP**

### Description

The TLF4277 is the ideal companion IC to supply active antennas for car infotainment applications. The adjustable output voltage makes the TLF4277 capable of supplying the majority of standard active antennas such as:

- FM/AM
- DAB
- XM
- SIRIUS

The TLF4277 is a monolithic integrated low drop out voltage regulator capable of supplying loads up to 200 mA. For an input voltage up to 40 V the TLF4277 provides an adjustable output voltage in a range from 5 V up to 12 V. The integrated current monitor function is a unique feature that provides diagnosis and system protection functionality. Fault conditions such as overtemperature and output overvoltage are monitored and indicated at the current sense output. The maximum output current limit of the device is adjustable to provide additional protection to the connected load.

Via the enable function the IC can be disabled to lower the power consumption. The PG-SSOP14 EP package provides an enhanced thermal performance within a SO8 body size.

Type	Package	Marking
TLF4277EL	PG-SSOP14 EP	TLF4277

## 2 Block Diagram

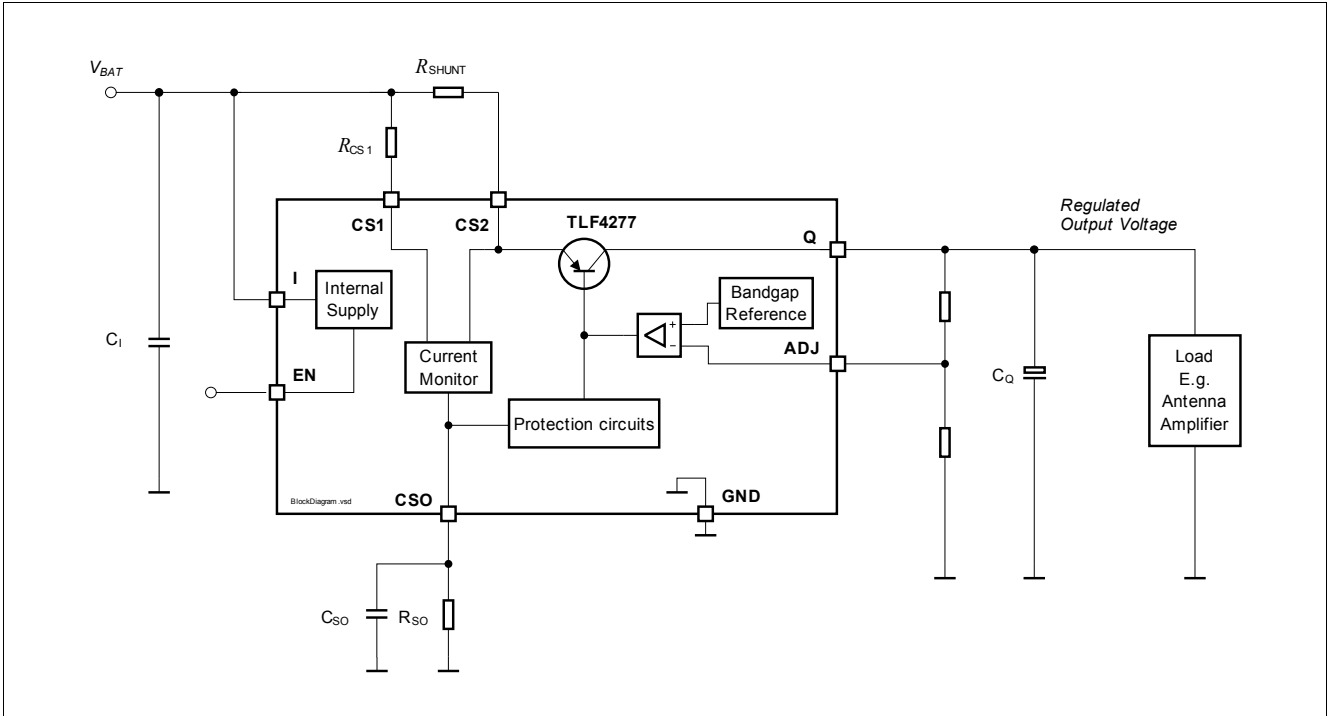

Figure 1 Block and simplified application diagram TLF4277 (Package PG-SSOP14 EP)

## 3 Pin Configuration

### 3.1 Pin Assignment

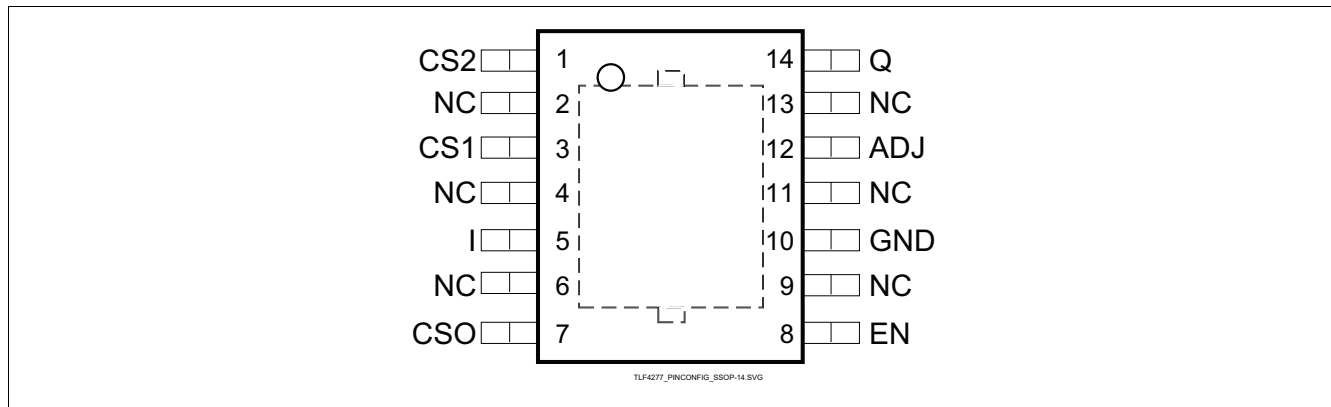

Figure 2 Pin Configuration (top view)

### 3.2 Pin Definitions and Functions

Pin	Symbol	Function
1	CS2	<b>Current Sense In 2</b> current monitor and power stage input
3	CS1	<b>Current Sense In 1</b> current monitor input
5	I	<b>IC Supply</b> Place a capacitor from I (Pin 5) to GND close to the IC for compensating line influences.
7	CSO	<b>Current Sense Out</b> current monitor and status output
8	EN	<b>Enable</b> high signal enables the regulator; low signal disables the regulator; connect to I, if the Enable function is not needed
10	GND	<b>Ground</b> connect pin to PCB and heat sink area
12	ADJ	<b>Voltage Adjust</b> connect an external voltage divider to configure the output voltage
14	Q	<b>Regulator Output</b> connect a capacitor between Q (Pin 8) and GND close to the IC pins, respecting the values given for its capacitance $C_Q$ and ESR in the table <a href="#">Chapter 4.2</a>
	PAD	<b>Heat sink</b> connect to PCB heat sink area and GND
2,4,6	NC	<b>Not Connected</b> Internally not connected; Connect to PCB GND
9,11,13	NC	<b>Not Connected</b> Internally not connected; Connect to PCB GND

## 4 General Product Characteristics

### 4.1 Absolute Maximum Ratings

#### Absolute Maximum Ratings <sup>1)</sup>

$T_j = -40\text{ °C}$  to  $+150\text{ °C}$ ; all voltages with respect to ground, positive current flowing into pin (unless otherwise specified)

Pos.	Parameter	Symbol	Limit Values		Unit	Conditions
			Min.	Max.		
<b>Voltage Ratings</b>						
4.1.1	IC Supply I	$V_I$	-42	45	V	–
4.1.2	Enable Input EN	$V_{EN}$	-42	45	V	–
4.1.3	Voltage Adjust Input ADJ	$V_{ADJ}$	-0.3	10	V	–
4.1.4	Regulator Output Q	$V_Q$	-1	40	V	–
4.1.5	Current Monitor Input CS1	$V_{CS1}$	-42	45	V	–
4.1.6	Current Monitor Input CS2	$V_{CS2}$	-42	45	V	–
4.1.7	Current Monitor Out CSO	$V_{CSO}$	-0.3	5	V	–
<b>Temperatures</b>						
4.1.8	Junction Temperature	$T_j$	-40	150	°C	–
4.1.9	Storage Temperature	$T_{stg}$	-55	150	°C	–
<b>ESD Susceptibility</b>						
4.1.10	ESD Resistivity to GND	$V_{ESD}$	-2	2	kV	HBM <sup>2)</sup>
4.1.11	ESD Resistivity	$V_{ESD}$	-1	1	kV	CDM <sup>3)</sup>

1) Not subject to production test, specified by design.

2) ESD susceptibility, HBM according to AEC-Q-100-002-JESD22-A114

3) ESD susceptibility, Charged Device Model "CDM" ESDA STM5.3.1

*Note: Integrated protection functions are designed to prevent IC destruction under fault conditions described in the data sheet. Fault conditions are considered as "outside" normal operating range. Protection functions are not designed for continuous repetitive operation.*

*Note: Stresses above the ones listed here may cause permanent damage to the device. Exposure to absolute maximum rating conditions for extended periods may affect device reliability.*

## 4.2 Functional Range

Pos.	Parameter	Symbol	Limit Values		Unit	Conditions
			Min.	Max.		
4.2.1	Input Voltage	$V_I$	5	40	V	–
4.2.2	Input Voltage Power Stage	$V_{CS2}$	$V_Q + 0.5$	40	V	$V_Q = V_{CS2} - V_{dr}$
4.2.3	Differential Input Voltage	$V_{SHUNT}$	0	0.5	V	$V_{SHUNT} = V_{BAT} - V_{CS2}$
4.2.4	Output Voltage Range	$V_Q$	5	12	V	–
4.2.5	Reference Resistor	$R_{CSI}$	100	1000	$\Omega$	–
4.2.6	Current Sense Output Resistor	$R_{CSO}$	1k	5k	$\Omega$	–
4.2.7	Current Sense Output Capacitor	$C_{CSO}$	1	4.7	$\mu\text{F}$	–
4.2.8	Junction Temperature	$T_j$	-40	150	$^{\circ}\text{C}$	–
4.2.9	Output Capacitor Requirements	$C_Q$	10	–	$\mu\text{F}$	– <sup>1)</sup>
4.2.10		$ESR_{CQ}$	–	3	$\Omega$	– <sup>2)</sup>

1) The minimum output capacitance requirement is applicable for a worst case capacitance tolerance of 30%

2) Relevant ESR value at  $f = 10$  kHz

*Note: Within the functional range the IC operates as described in the circuit description. The electrical characteristics are specified within the conditions given in the related electrical characteristics table.*

## 4.3 Thermal Resistance

Pos.	Parameter	Symbol	Limit Values			Unit	Conditions
			Min.	Typ.	Max.		
4.3.1	Junction to Case... <sup>1)</sup>	$R_{thJC}$	–	–	10	K/W	measured to the exposed pad
4.3.2	Junction to Ambient <sup>1)</sup>	$R_{thJA}$	–	150	–	K/W	Footprint only <sup>2)</sup>
4.3.3			–	64	–	K/W	300 mm <sup>2</sup> PCB heat sink area <sup>2)</sup>
4.3.4			–	55	–	K/W	600 mm <sup>2</sup> PCB heat sink area <sup>2)</sup>
4.3.5			–	50	–	K/W	2s2p PCB <sup>3)</sup>

1) Not subject to production test, specified by design

2) Specified  $R_{thJA}$  value is according to Jedec JESD 51-3 at natural convection on FR4 1s0p board; The Product (Chip+Package) was simulated on a 76.2 × 114.3 × 1.5 mm<sup>3</sup> board with 1 copper layer (1 × 70 $\mu\text{m}$  Cu).

3) Specified  $R_{thJA}$  value is according to Jedec JESD51-2,-5,-7 at natural convection on FR4 2s2p board; The Product (Chip+Package) was simulated on a 76.2 × 114.3 × 1.5 mm<sup>3</sup> board with 2 inner copper layers (2 × 70 $\mu\text{m}$  Cu, 2 × 35 $\mu\text{m}$  Cu). Where applicable a thermal via array under the exposed pad contacted the first inner copper layer.

## 5 Voltage Regulator

### 5.1 Description Voltage Regulator

The output voltage  $V_Q$  is controlled by comparing the feedback voltage ( $V_{ADJ}$ ) to an internal reference voltage and driving a PNP pass transistor accordingly. The control loop stability depends on the output capacitor  $C_Q$ , the output capacitor ESR, the load current and the chip temperature. To ensure stable operation, the output capacitor's capacitance and its equivalent series resistor ESR requirements given in the [Table 4.2 "Functional Range" on Page 7](#) have to be maintained. For stability details please refer to the typical performance graph "Output Capacitor Series Resistivity  $ESR_{CQ}$ " on [Page 11](#). In addition the output capacitor may need to be sized larger to buffer load transients.

An input capacitor  $C_1$  is not needed for the control loop stability, but recommended to buffer line influences. Connect the capacitors close to the IC terminals. In general a buffered supply voltage is recommended for the device. For details see [Chapter 9](#).

Protection circuitry prevents the IC as well as the application from destruction in case of catastrophic events. The integrated safeguards consist of output current limitation, reverse polarity protection as well as thermal shutdown in case of overtemperature.

In order to avoid excessive power dissipation that could never be handled by the pass element and the package, an integrated safe operation monitor lowers the maximum output current input voltages above  $V_{BAT} = 22\text{ V}$ .

The thermal shutdown circuit prevents the IC from immediate destruction under fault conditions (e.g. output continuously short-circuited) by switching off the power stage. After the chip has cooled down, the regulator restarts. This leads to an oscillatory behavior of the output voltage until the fault is removed. However, junction temperatures above  $150\text{ °C}$  are outside the maximum ratings and therefore significantly reduce the IC lifetime.

The TLF4277 allows a negative supply voltage. However, several small currents are flowing into the IC increasing its junction temperature. This reverse current has to be considered for the thermal design, respecting that the thermal protection circuit is not operating during reverse polarity condition.

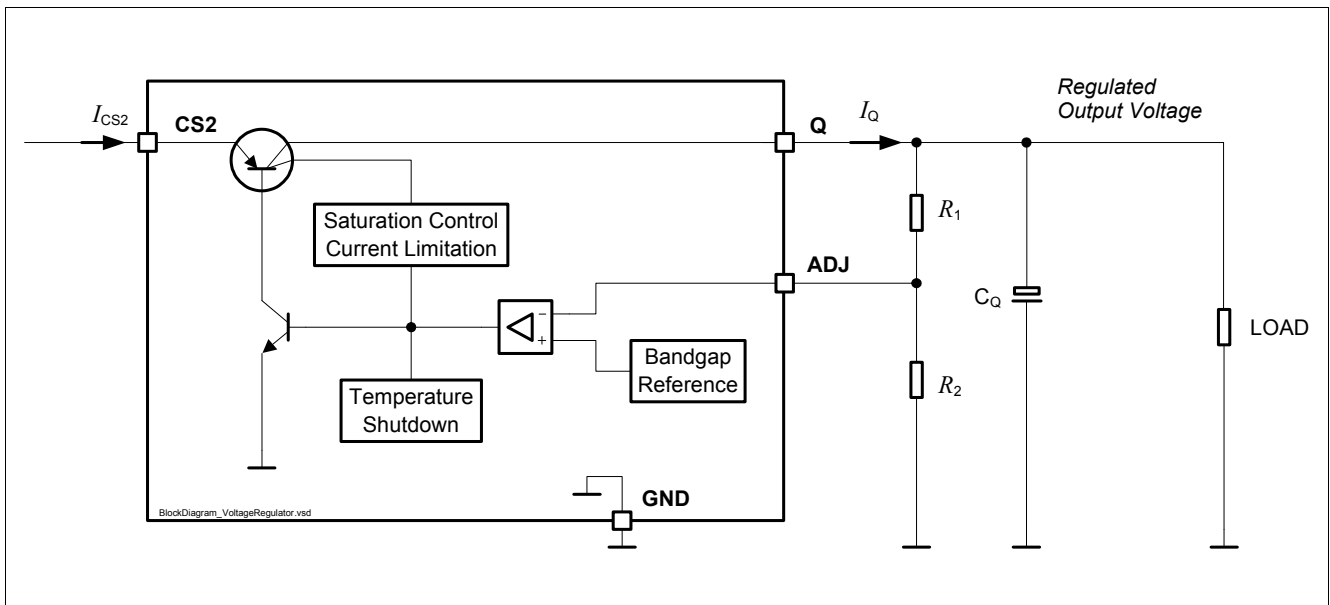

Figure 3 Block Diagram Voltage Regulator Circuit

## 5.2 Electrical Characteristics Voltage Regulator

### Electrical Characteristics: Voltage Regulator

$V_{BAT} = 13.5 \text{ V}$ ,  $T_j = -40 \text{ °C}$  to  $+150 \text{ °C}$ , all voltages with respect to ground, direction of currents as shown in **Figure 7 “Measuring Circuit” on Page 19** (unless otherwise specified)

Pos.	Parameter	Symbol	Limit Values			Unit	Conditions
			Min.	Typ.	Max.		
5.2.1	Reference Voltage	$V_{REF,int}$	–	1.22	–	V	<sup>1)</sup> –
5.2.2	Output Voltage Tolerance <sup>2)</sup>	$V_Q$	–2	–	2	%	$1 \text{ mA} \leq I_Q \leq 200 \text{ mA}$ ; $9 \text{ V} \leq V_{BAT} \leq 16 \text{ V}$
5.2.3			–2	–	2	%	$1 \text{ mA} \leq I_Q \leq 150 \text{ mA}$ ; $6 \text{ V} \leq V_{BAT} \leq 16 \text{ V}$
5.2.4			–2	–	2	%	$1 \text{ mA} \leq I_Q \leq 100 \text{ mA}$ ; $16 \text{ V} \leq V_{BAT} \leq 32 \text{ V}^{3)}$
5.2.5			–2	–	2	%	$1 \text{ mA} \leq I_Q \leq 10 \text{ mA}$ ; $32 \text{ V} \leq V_{BAT} \leq 45 \text{ V}^{3)}$
5.2.6	Load Regulation steady-state	$dV_{Q,load}$	–30	–5	–	mV	$I_Q = 1 \text{ mA}$ to $150 \text{ mA}$ ; $V_{BAT} = 6 \text{ V}$ $V_Q = 5 \text{ V}$
5.2.7	Line Regulation steady-state	$dV_{Q,line}$	–	5	20	mV	$V_{BAT} = 6 \text{ V}$ to $32 \text{ V}$ ; $I_Q = 5 \text{ mA}$ $V_Q = 5 \text{ V}$
5.2.8	Power Supply Ripple Rejection <sup>1)</sup>	$PSRR$	60	65	–	dB	$f_{ripple} = 100 \text{ Hz}$ ; $V_{ripple} = 1 \text{ Vpp}$
5.2.9	Dropout Voltage	$V_{dr}$	–	120	250	mV	$I_Q = 50 \text{ mA}^{4)}$
5.2.10			$V_{dr} = V_{CS2} - V_Q$	–	250	500	mV
5.2.11	Output Current Limitation	$I_{Q,max}$	300	–	600	mA	$0 \text{ V} \leq V_Q \leq 0.95 * V_{Q,nom}$ ; CSO pin connected to GND
5.2.12	Reverse Current	$I_Q$	–2	–1	–	mA	$V_{BAT} = V_{CS2} = 0 \text{ V}$ ; $V_Q = 5 \text{ V}$
5.2.13	Reverse Current at Negative Input Voltage	$I_{BAT}$	–10	–6	–	mA	$V_{BAT} = -16 \text{ V}$ ; $V_Q = 0 \text{ V}$
5.2.14	Overtemperature Shutdown Threshold	$T_{j,sd}$	151	–	200	°C	$T_j$ increasing <sup>1)</sup>
5.2.15	Overtemperature Shutdown Threshold Hysteresis	$T_{j,hy}$	–	25	–	K	$T_j$ decreasing <sup>1)</sup>

1) Parameter not subject to production test; specified by design.

2) Referring to the device tolerance only, the tolerance of the resistor divider can cause additional deviation.

3) See typical performance graph for details.

4) Measured when the output voltage  $V_Q$  has dropped 100 mV from its nominal value.

### 5.3 Application Information for the setting the variable output voltage

The output voltage of the TLF4277 can be adjusted between 5 V and 12 V by an external output voltage divider, closing the control loop to the voltage adjust pin ADJ.

The voltage at pin ADJ is compared to the internal reference of typical 1.22 V in an error amplifier. It controls the output voltage.

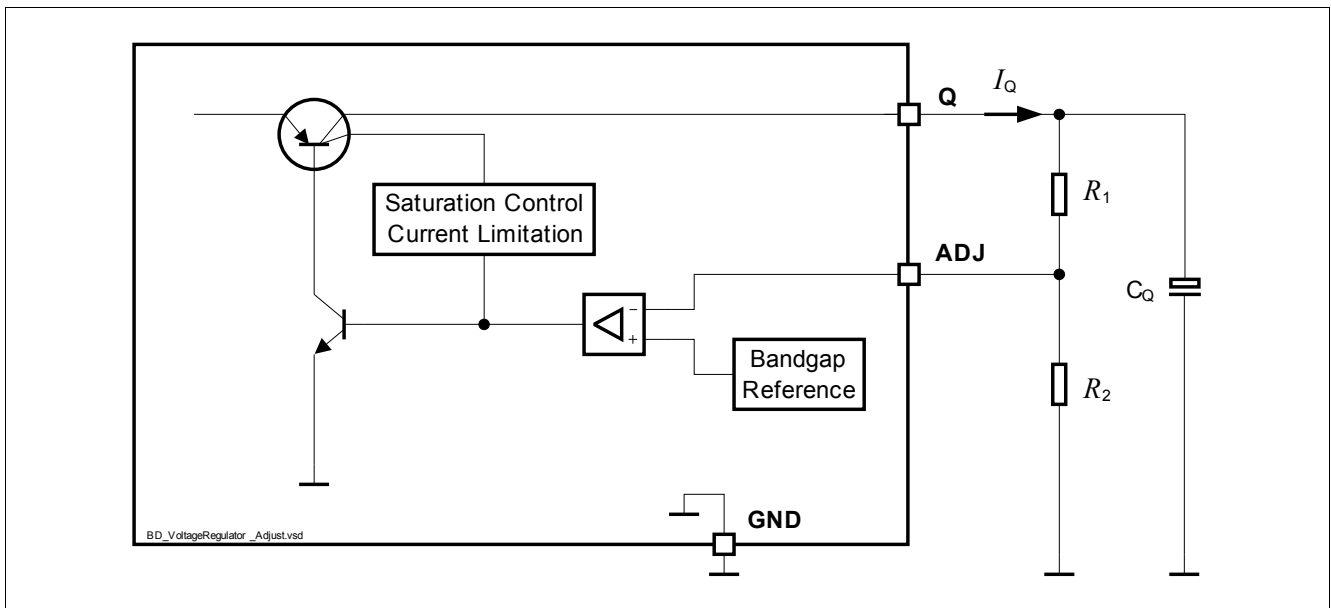

**Figure 4 Application Detail External Components at Output for Variable Voltage Regulator**

The output voltage is calculated according to [Equation \(1\)](#):

$$V_Q = (R_1 + R_2) / R_2 \times V_{REF,int}, \text{ neglecting } I_{ADJ} \tag{1}$$

$V_{REF,int}$  is typically 1.22 V.

To avoid errors caused by leakage current  $I_{ADJ}$ , we recommend to choose the resistor value for  $R_2 < 27 \text{ k}\Omega$ .

The accuracy of the resistors for the external voltage divider can lead to a higher tolerance of the output voltage. To achieve a reasonable accuracy resistors with a tolerance of 1% or lower are recommended for the feedback divider.

### 5.4 Typical Performance Characteristics Voltage Regulator

Reference Voltage  $V_{REF,int}$  vs. Junction Temperature  $T_j$

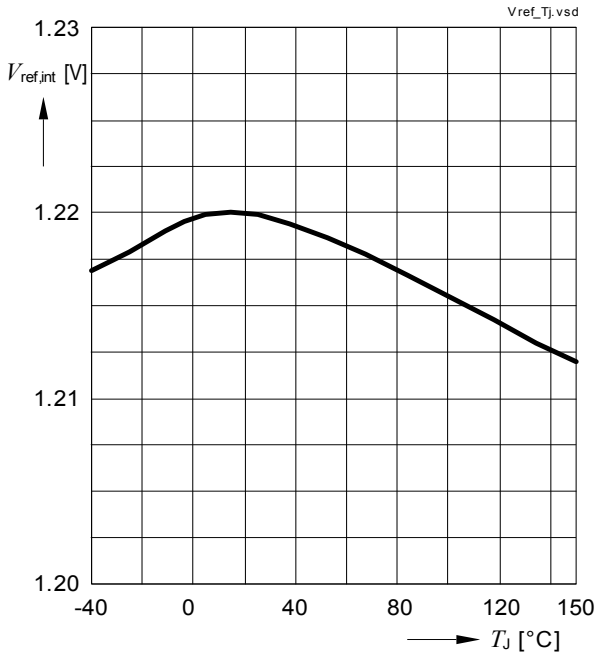

Output Capacitor Series Resistivity  $ESR_{C_Q}$  vs. Output Current  $I_Q$

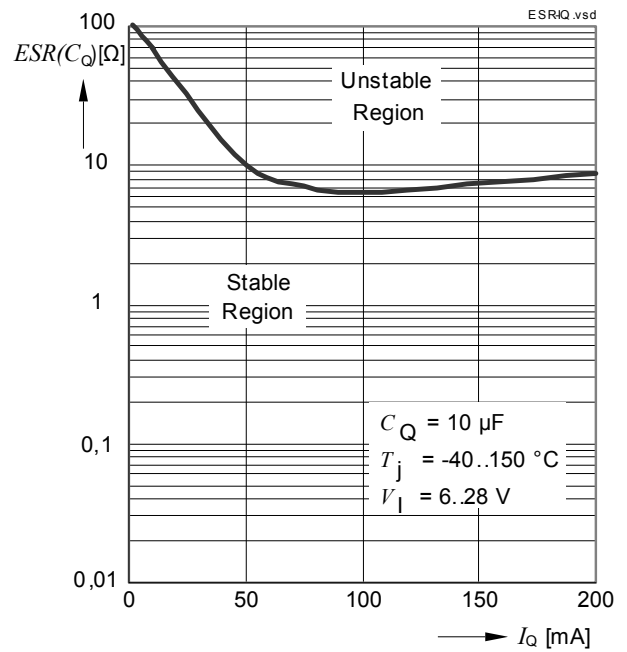

Dropout Voltage  $V_{dr}$  vs. Output Current  $I_Q$

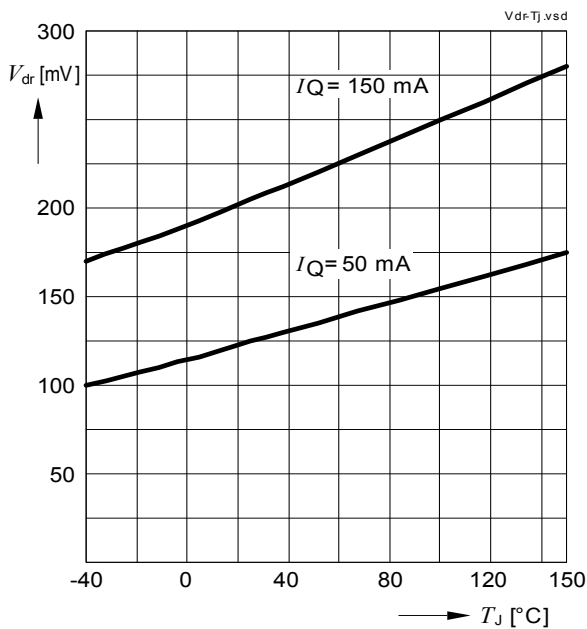

Power Supply Ripple Rejection  $PSRR$

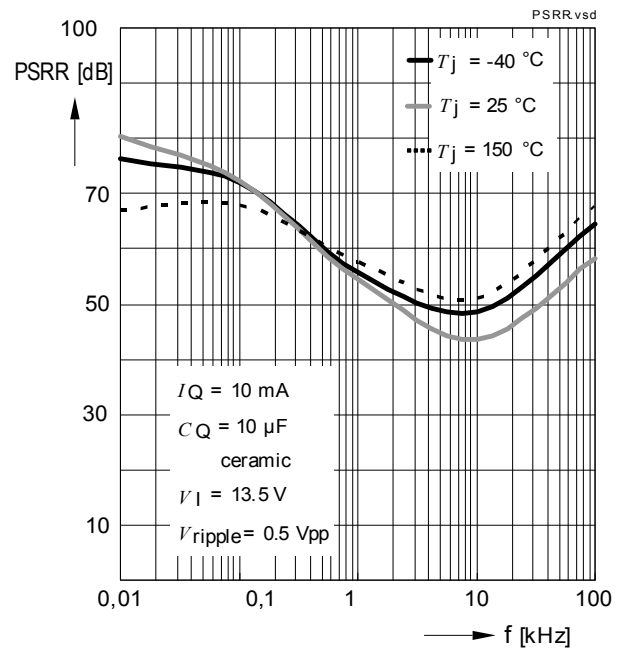

## 6 Current Consumption

### 6.1 Electrical Characteristics Current Consumption

#### Electrical Characteristics: Current Consumption

$V_{BAT} = 13.5 \text{ V}$ ,  $T_j = -40 \text{ °C}$  to  $+150 \text{ °C}$ , all voltages with respect to ground; direction of currents as shown in [Figure 7 “Measuring Circuit” on Page 19](#) (unless otherwise specified)

Pos.	Parameter	Symbol	Limit Values			Unit	Conditions
			Min.	Typ.	Max.		
6.1.1	Current Consumption	$I_{q,on}$	–	150	200	$\mu\text{A}$	$I_Q \leq 200 \mu\text{A}$ ; $T_j \leq 25 \text{ °C}$ ; $V_{EN} = 5 \text{ V}$ ; $I_q = I_1 + I_{CS2} - I_Q$
6.1.2			–	175	250	$\mu\text{A}$	$I_Q \leq 200 \mu\text{A}$ ; $T_j \leq 85 \text{ °C}$ ; $V_{EN} = 5 \text{ V}$ ; $I_q = I_1 + I_{CS2} - I_Q$
6.1.3			–	1.2	2.6	$\text{mA}$	$I_Q = 50 \text{ mA}$ $V_{EN} = 5 \text{ V}$ ; $I_q = I_1 + I_{CS2} - I_Q$
6.1.4			–	3.5	6	$\text{mA}$	$I_Q = 100 \text{ mA}$ $V_{EN} = 5 \text{ V}$ ; $I_q = I_1 + I_{CS2} - I_Q$
6.1.5			–	5	10	$\text{mA}$	$I_Q = 150 \text{ mA}$ $V_{EN} = 5 \text{ V}$ ; $I_q = I_1 + I_{CS2} - I_Q$
6.1.6	Current Consumption	$I_{q,off}$	–	–	3	$\mu\text{A}$	$T_j \leq 25 \text{ °C}$ $V_{EN} = 0.8 \text{ V}$ $I_q = I_1 + I_{CS2} - I_Q$
6.1.7			–	–	5	$\mu\text{A}$	$T_j \leq 85 \text{ °C}$ ; $V_{EN} = 0.8 \text{ V}$ $I_q = I_1 + I_{CS2} - I_Q$

## 6.2 Typical Performance Graphs Current Consumption

Current Consumption  $I_{q,off}$  vs. Junction Temperature  $T_j$

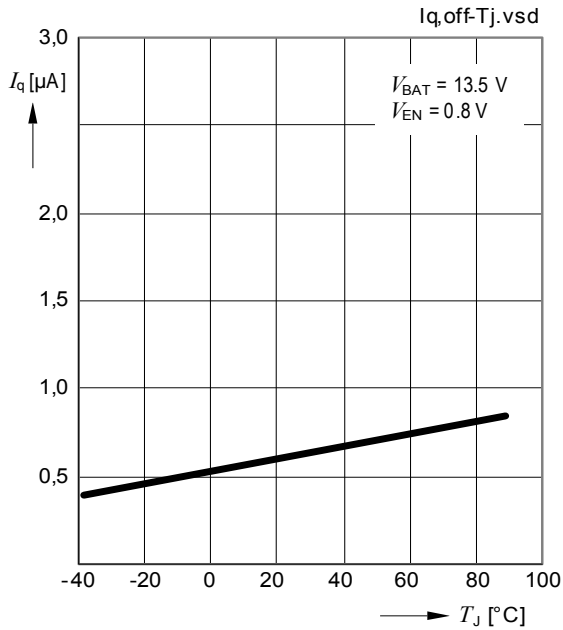

Current Consumption  $I_{q,on}$  vs. Junction Temperature  $T_j$

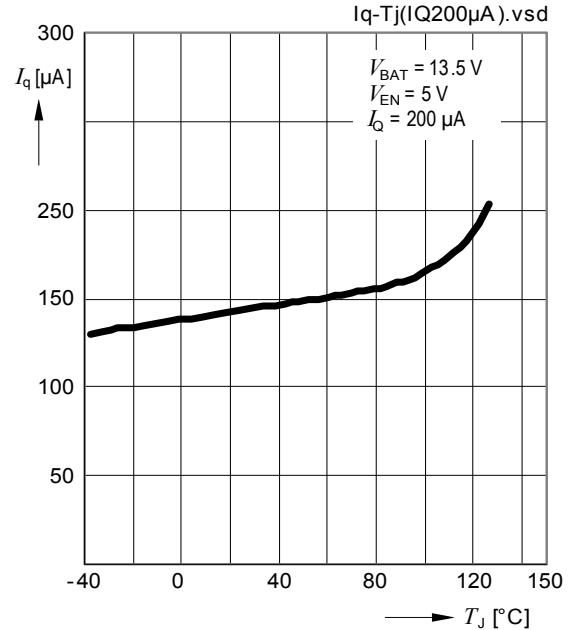

Current Consumption  $I_{q,on}$  vs. Output Current  $I_Q$

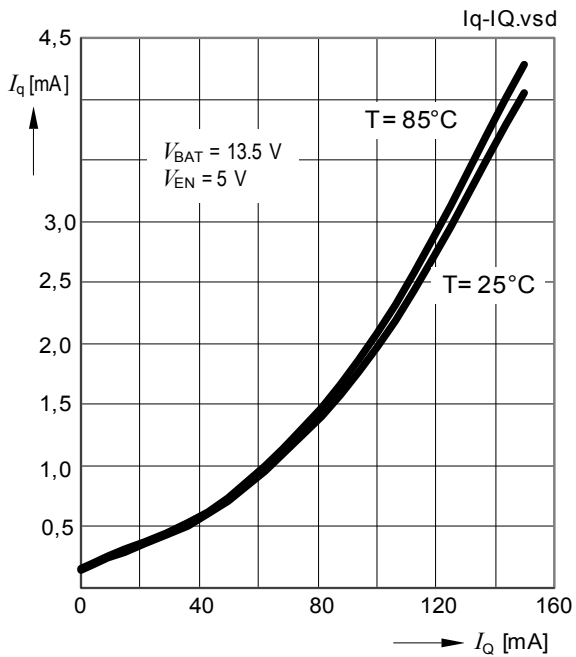

## 7 Current and Protection Monitor Functions

### 7.1 Functional Description Current and Protection Monitors

The TLF4277 provides a set of advanced monitor functionality. The current flowing into the power stage can be monitored at the CSO output. In addition the current limitation can be adjusted via external resistors. Events of the implemented protection functions are reported through dedicated voltage levels at the CSO output. This information can be processed by an external  $\mu\text{C}$  for system analysis and failure identification. The monitored events are over-current, overvoltage, and temperature shutdown.

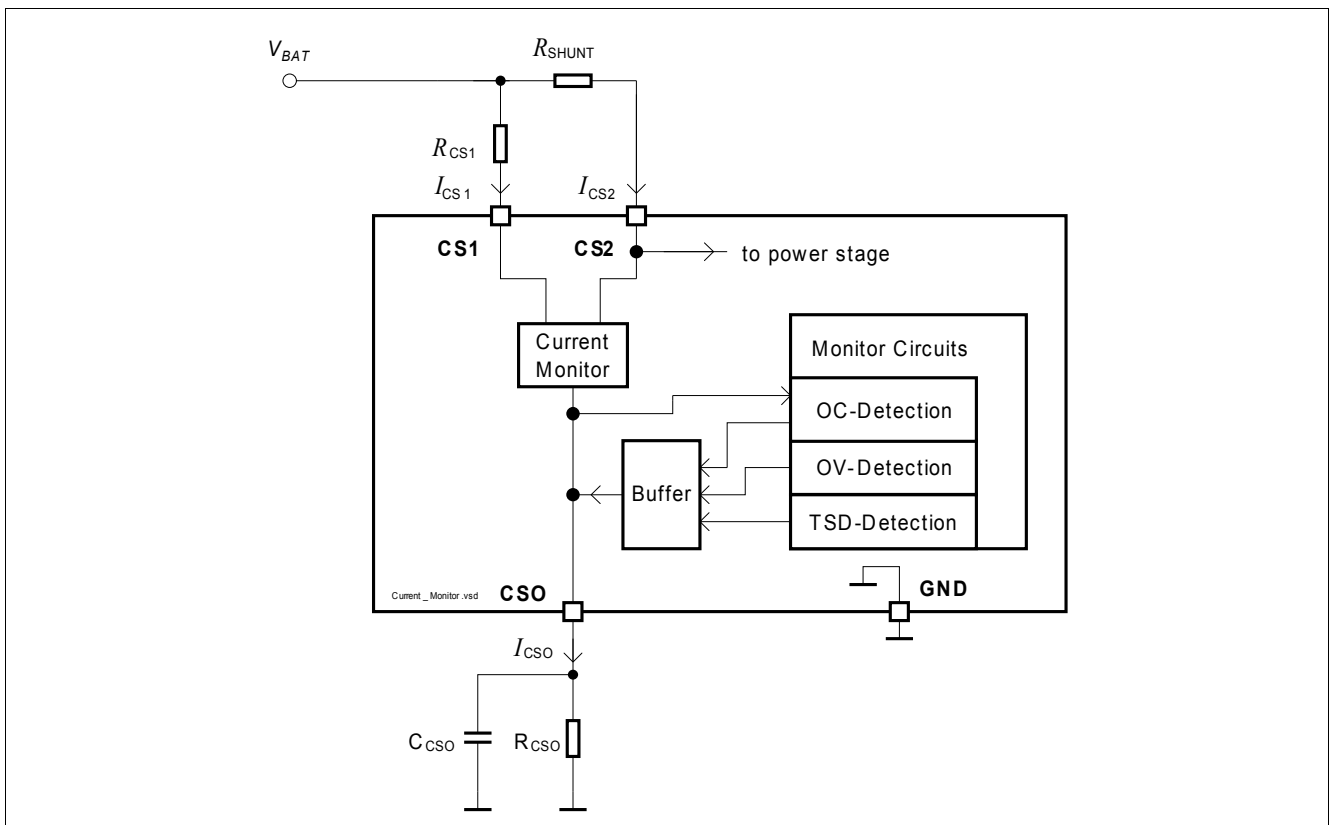

**Figure 5** Block diagram current and protection monitor

To reduce possible effects from the supply voltage  $V_{\text{BAT}}$  additional filtering in of the supply voltage is recommended. A combination of a 100 nF capacitor and an additional buffer capacitor of 10  $\mu\text{F}$  or higher should be placed as close a possible to the IC terminal, which are connected to  $V_{\text{BAT}}$ .

**Figure 6** shows the output level at the CSO pin versus the operation or fault condition. The graph is valid for the following set up of external components:

- $R_{\text{SHUNT}} = 1\ \Omega$
- $R_{\text{CS1}} = 100\ \Omega$
- $C_{\text{CSO}} = 2.2\ \mu\text{F}$
- $R_{\text{CSO}} = 1.5\ \text{k}\Omega$

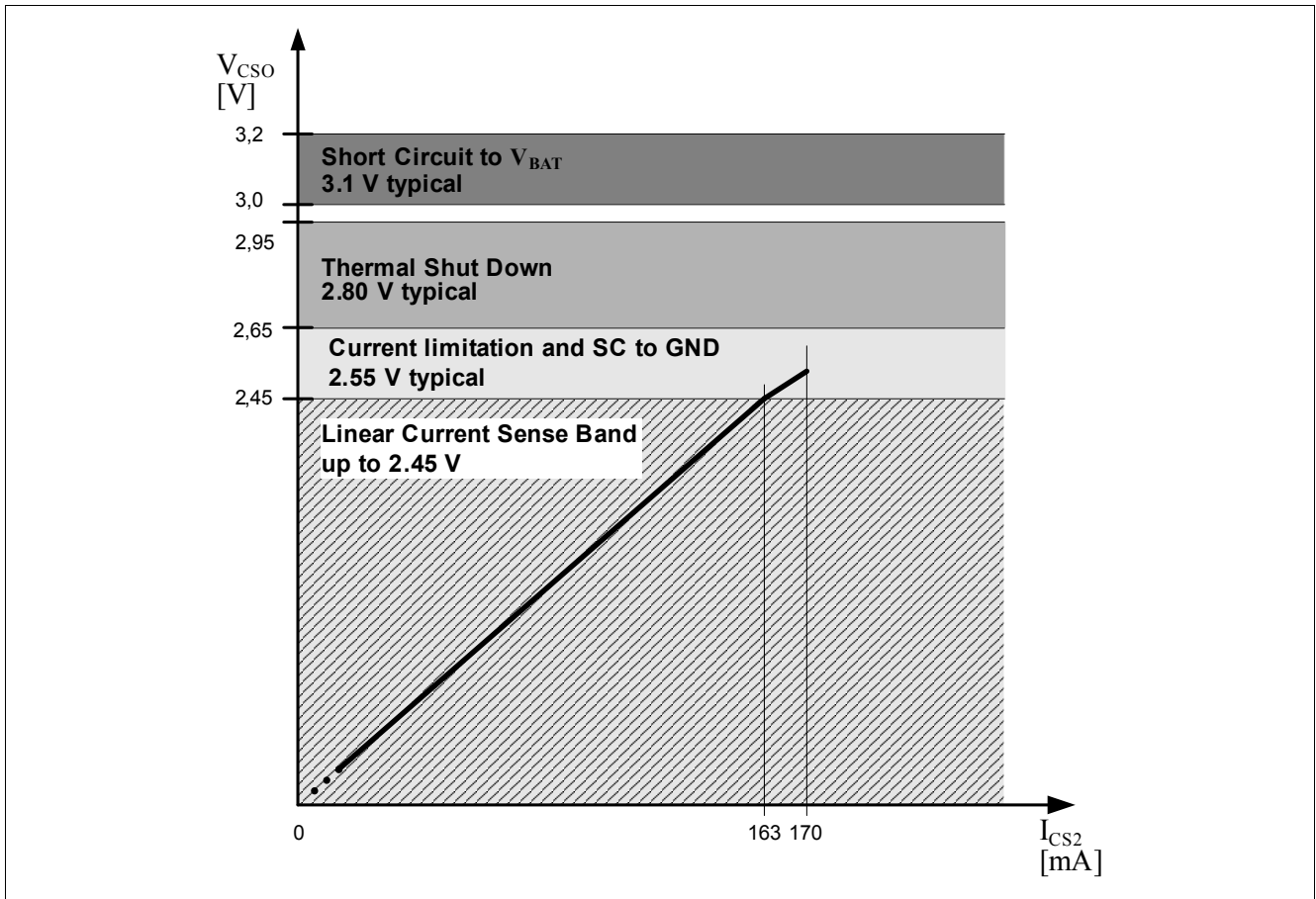

Figure 6 Output levels and functionality of the CSO output<sup>1)</sup>

### 7.1.1 Linear Current Monitor

Inside the linear current monitor area the current driven out of the CSO pin is proportional to the voltage which is measured between pin CS1 and CS2.

The level of the current  $I_{CSO}$  can be adjusted according to [Equation \(2\)](#):

$$I_{CSO} = \frac{V_{BAT} - V_{CS2}}{R_{CS1}} = I_{CS2} \times \frac{R_{SHUNT}}{R_{CS1}}$$

Adjustment  $I_{CSO}$  (2)

$$V_{CSO} = \frac{(V_{BAT} - V_{CS2}) \times R_{CSO}}{R_{CS1}} = V_{SHUNT} \times \frac{R_{CSO}}{R_{CS1}}$$

Adjustment of the voltage level for  $V_{CSO}$  (3)

1) The graph is just an example and only valid for an certain configuration of the external components

### 7.1.2 Adjustable Output Current Limitation

The TLF4277 has an adjustable current limitation for the current flowing into the power stage (pin CS2). If the level of the voltage drop across the sense resistor  $R_{SHUNT}$  is higher than the desired linear monitor range the output current of the TLF4277 will be limited.

$$I_{CS2,lim} = \frac{2.55V \times R_{CS1}}{R_{SHUNT} \times R_{CSO}}$$

Setting of the adjustable current limitation

(4)

A voltage level as defined in [Table 7.2.6](#) on Page 17 will be applied at the CSO pin.

To achieve a current limitation of 170mA the following configuration can be used:

$$I_{CS2,lim} = \frac{2.55V \times 100\Omega}{1\Omega \times 1.5k\Omega} = 170mA$$

$$R_{SHUNT} = 1\Omega$$

$$R_{CS1} = 100\Omega$$

$$R_{CSO} = 1.5k\Omega$$

### 7.1.3 Overvoltage Detection

To detect a possible short circuit of the output to a higher supply rail the TLF4277 has an overvoltage detection implemented. An overvoltage will be detected, if the voltage level at the ADJ pin is 20% higher than the internal reference voltage  $V_{REF,int}$  defined in [Table 5.2.1](#) on Page 9.

Under this condition the CSO pin will be driven through an internal voltage buffer with a voltage level as defined in [Table 7.2.7](#) on Page 17.

### 7.1.4 Thermal Shutdown Detection

If the junction temperature will exceed the limits defined in the [Table 5.2.14](#) on Page 9 the TLF4277 will disable the output voltage. In this case a voltage level as defined in [Table 7.2.8](#) on Page 17 will be applied at the CSO pin.

## 7.2 Electrical Characteristics Current and Protection Monitor

### Electrical Characteristics: Current Monitor Function

$V_{BAT} = 13.5\text{ V}$ ,  $T_j = -40\text{ °C}$  to  $+150\text{ °C}$ , all voltages with respect to ground, direction of currents as shown in [Figure 7 “Measuring Circuit” on Page 19](#) (unless otherwise specified)

Pos.	Parameter	Symbol	Limit Values			Unit	Conditions
			Min.	Typ.	Max.		
<b>Linear Current Monitor</b>							
7.2.1	Current Sense Output Current $I_{CSO}$ ( $V_{SHUNT} = 10\text{ mV}$ )	$I_{CSO}$	0.08	0.1	0.12	mA	$T_j = 25\text{ °C}$ $R_{SHUNT} = 1\text{ }\Omega$ $R_{CS1} = 100\text{ }\Omega$ $R_{CSO} = 1.5\text{ k}\Omega$ <sup>1)</sup>
7.2.2	( $V_{SHUNT} = 50\text{ mV}$ )		0.47	0.5	0.53	mA	
7.2.3	( $V_{SHUNT} = 100\text{ mV}$ )		0.97	1	1.03	mA	
7.2.4	( $V_{SHUNT} = 150\text{ mV}$ )		1.45	1.5	1.55	mA	
<b>Adjustable Current Limitation</b>							
7.2.5	Adjustable Current Limit	$I_{CS2,lim}$	162	170	187	mA	$R_{SHUNT} = 1\text{ }\Omega$ $R_{CS1} = 100\text{ }\Omega$ $R_{CSO} = 1.5\text{ k}\Omega$ $V_Q < 0,95 * V_{Q,nom}$ <sup>1)</sup>
7.2.6	CSO Voltage Level Current limitation	$V_{CSO,cur\_lim}$	2.45	2.55	2.65	V	
<b>Output Level Overvoltage Detected</b>							
7.2.7	CSO Voltage Level Overvoltage detected	$V_{CSO,ov}$	3.0	3.1	3.2	V	$V_{ADJ} > 1.2 * V_{REF,nom}$ <sup>1)</sup>
<b>Output Level Overtemperature Detected</b>							
7.2.8	CSO Voltage Level Overtemperature Detected <sup>2)</sup>	$V_{CSO,TSD}$	2.65	2.8	2.95	V	$150\text{ °C} < T_j < 180\text{ °C}$

1) Referring to the device tolerance only, the tolerance of the external components can cause additional deviation

2) Specified by design; not subject to production test

## 8 Enable Function

### 8.1 Description Enable Function

The TLF4277 can be turned on or turned off via the EN Input. With voltage levels higher than  $V_{EN,high}$  applied to the EN Input the device will be completely turned on. A voltage level lower than  $V_{EN,low}$  sets the device to low quiescent current mode. In this condition the device is turned off and is not functional. The Enable Input has an build in hysteresis to avoid toggling between ON/OFF state, if signals with slow slope are applied to the input.

### 8.2 Electrical Characteristics Enable Function

#### Electrical Characteristics: Enable Function

$V_{BAT} = 13.5\text{ V}$ ,  $T_j = -40\text{ °C}$  to  $+150\text{ °C}$ , all voltages with respect to ground, direction of currents as shown in [Figure 7 “Measuring Circuit” on Page 19](#) (unless otherwise specified)

Pos.	Parameter	Symbol	Limit Values			Unit	Conditions
			Min.	Typ.	Max.		
8.2.1	Enable Low Signal Valid	$V_{EN,low}$	–	–	0.8	V	–
8.2.2	Enable High Signal Valid	$V_{EN,high}$	2	–	–	V	$V_Q$ settled
8.2.3	Enable Threshold Hysteresis	$V_{EN,hyst}$	50	–	–	mV	–
8.2.4	Enable Input current	$I_{EN}$	–	–	2	$\mu\text{A}$	$V_{EN} = 5\text{ V}$
8.2.5	Enable internal pull-down resistor	$R_{EN}$	3	4.5	6	$\text{M}\Omega$	–

## 9 Application Information

### 9.1 Measurement Circuit

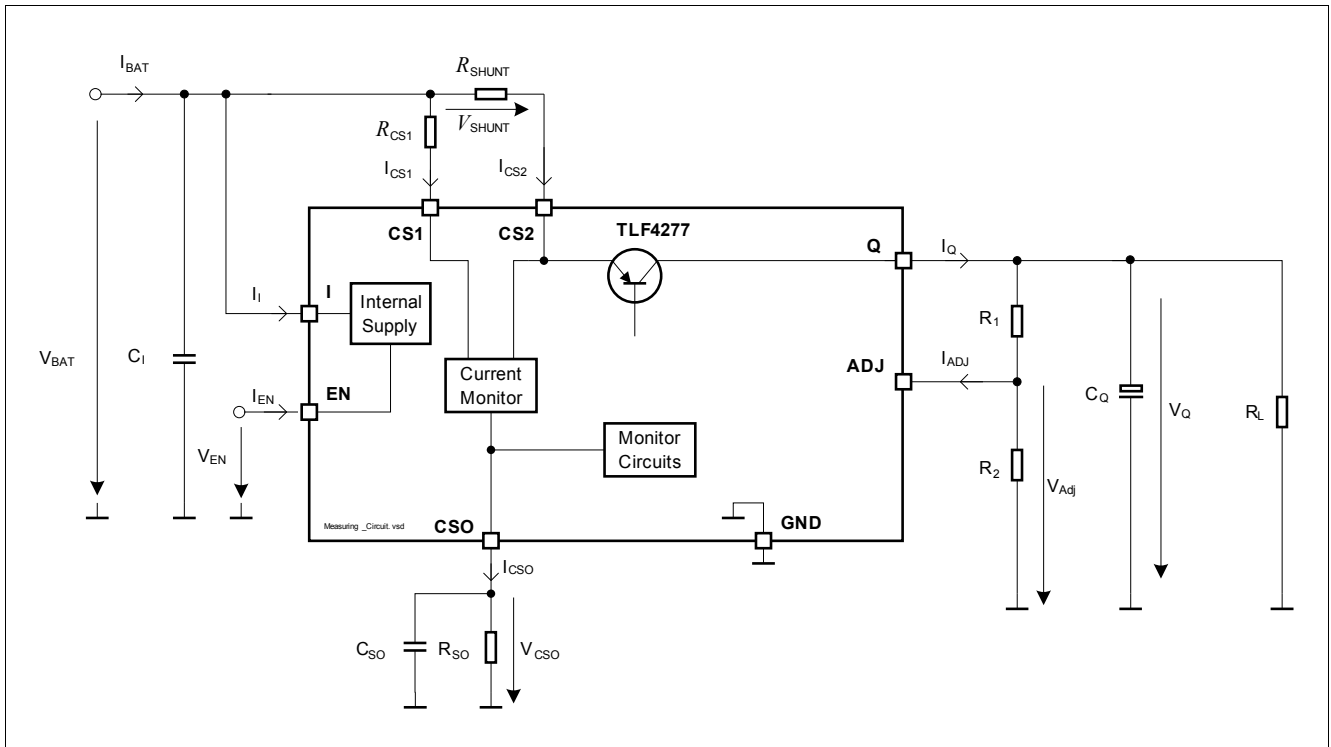

**Figure 7** Measuring Circuit

Measurement Set Up:

$$R_{SHUNT} = 1\ \Omega$$

$$R_{CS1} = 100\ \Omega$$

$$C_{CSO} = 2.2\ \mu\text{F}$$

$$R_{CSO} = 1.5\ \text{k}\Omega$$

$$R_1 = 38\ \text{k}\Omega$$

$$R_2 = 12\ \text{k}\Omega$$

$$C_Q = 10\ \mu\text{F}$$

## 10 Package Outlines

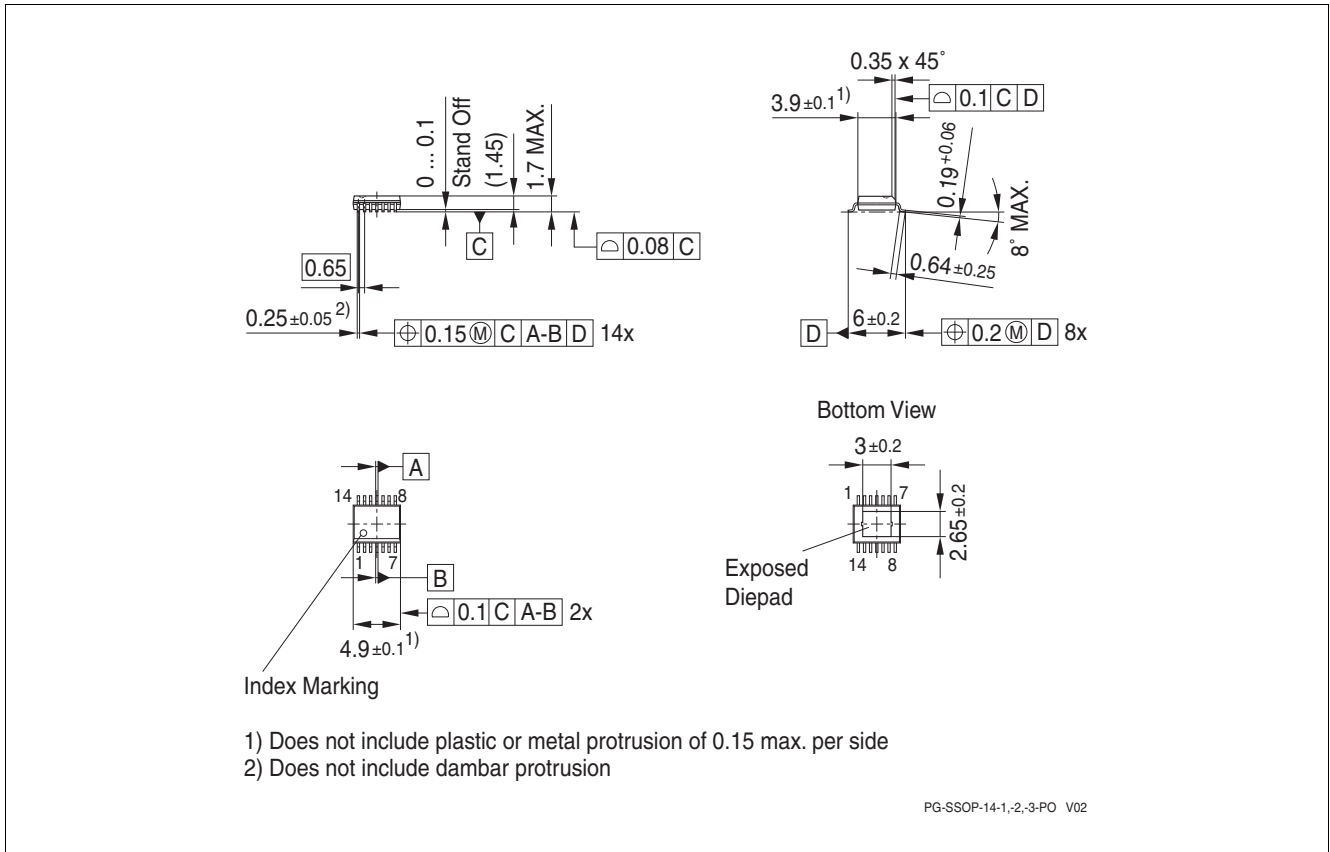

Figure 8 PG-SSOP14 EP

### Green Product (RoHS compliant)

To meet the world-wide customer requirements for environmentally friendly products and to be compliant with government regulations the device is available as a green product. Green products are RoHS-Compliant (i.e. Pb-free finish on leads and suitable for Pb-free soldering according to IPC/JEDEC J-STD-020).

## 11 Revision History

Revision	Date	Changes
1.02	2011-07-04	Updated Cover Page Fixed Linear Current Monitor formulas (2,3) on Page <b>15</b>
1.01	2011-05-07	Template Update
1.0	2009-05-07	Data Sheet

**Edition 2011-07-05**

**Published by  
Infineon Technologies AG  
81726 Munich, Germany**

**© 2011 Infineon Technologies AG  
All Rights Reserved.**

### **Legal Disclaimer**

The information given in this document shall in no event be regarded as a guarantee of conditions or characteristics. With respect to any examples or hints given herein, any typical values stated herein and/or any information regarding the application of the device, Infineon Technologies hereby disclaims any and all warranties and liabilities of any kind, including without limitation, warranties of non-infringement of intellectual property rights of any third party.

### **Information**

For further information on technology, delivery terms and conditions and prices, please contact the nearest Infineon Technologies Office ([www.infineon.com](http://www.infineon.com)).

### **Warnings**

Due to technical requirements, components may contain dangerous substances. For information on the types in question, please contact the nearest Infineon Technologies Office.

Infineon Technologies components may be used in life-support devices or systems only with the express written approval of Infineon Technologies, if a failure of such components can reasonably be expected to cause the failure of that life-support device or system or to affect the safety or effectiveness of that device or system. Life support devices or systems are intended to be implanted in the human body or to support and/or maintain and sustain and/or protect human life. If they fail, it is reasonable to assume that the health of the user or other persons may be endangered.

## Looking for pricing, stock, or lifecycle information?

Click below to explore more details on WIN SOURCE:

- ⊖ [View TLF4277E on WIN SOURCE](#)
- ⊖ [Infineon Technologies Information](#)

## Optimize Your Supply Chain with WIN SOURCE Solutions

- ✓ Global Sourcing Solution
- ✓ Obsolete Management
- ✓ Cost Control Management
- ✓ Shortage Management
- ✓ Alternative Solution
- ✓ Excess Inventory Management