



**THE DATASHEET OF
TLC59281DBQR**



16-Channel, Constant-Current LED Driver

Check for Samples: [TLC59281](#)

FEATURES

- 16 Channels, Constant-Current Sink Output with On/Off Control
- 35-mA Capability (Constant-Current Sink)
- 10-ns High-Speed Constant-Current Switching Transient Time
- Low On-Time Error
- LED Power-Supply Voltage up to 17 V
- $V_{CC} = 3.0\text{ V to }5.5\text{ V}$
- Constant-Current Accuracy:
 - Channel-to-Channel = $\pm 1\%$
 - Device-to-Device = $\pm 1\%$
- CMOS Logic Level I/O
- 35-MHz Data Transfer Rate
- 20-ns BLANK Pulse Width
- Operating Temperature: $-40^{\circ}\text{C to }+85^{\circ}\text{C}$

APPLICATIONS

- LED Video Displays
- Message Boards
- Illumination

DESCRIPTION

The TLC59281 is a 16-channel, constant-current sink LED driver. Each channel can be turned on/off by writing serial data to an internal register. The constant-current value of all 16 channels is set by a single external resistor.

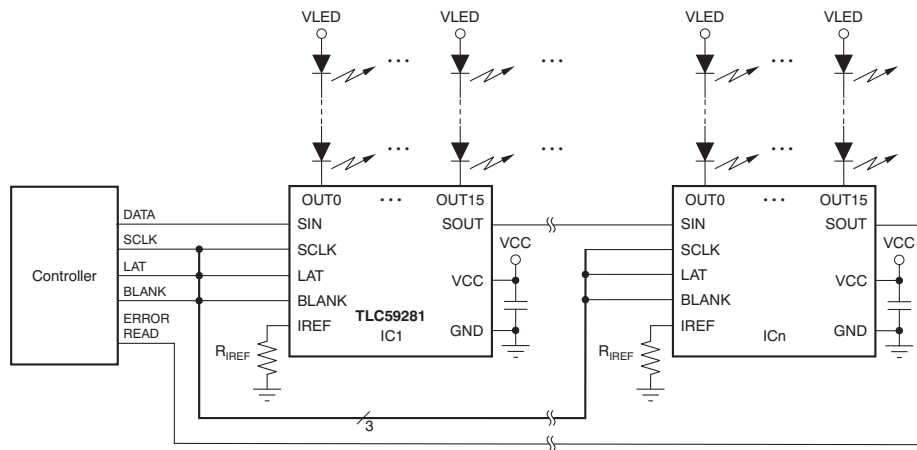

Typical Application Circuit (Multiple Daisy-Chained TLC59281s)



Please be aware that an important notice concerning availability, standard warranty, and use in critical applications of Texas Instruments semiconductor products and disclaimers thereto appears at the end of this data sheet.

All trademarks are the property of their respective owners.



This integrated circuit can be damaged by ESD. Texas Instruments recommends that all integrated circuits be handled with appropriate precautions. Failure to observe proper handling and installation procedures can cause damage.

ESD damage can range from subtle performance degradation to complete device failure. Precision integrated circuits may be more susceptible to damage because very small parametric changes could cause the device not to meet its published specifications.

PACKAGE/ORDERING INFORMATION⁽¹⁾

PRODUCT	PACKAGE-LEAD	ORDERING NUMBER	TRANSPORT MEDIA, QUANTITY
TLC59281	SSOP-24/QSOP-24	TLC59281DBQR	Tape and Reel, 2500
		TLC59281DBQ	Tube, 50
TLC59281	QFN-24	TLC59281RGER	Tape and Reel, 3000
		TLC59281RGE	Tape and Reel, 250

(1) For the most current package and ordering information, see the Package Option Addendum at the end of this document, or visit the device product folder at www.ti.com.

ABSOLUTE MAXIMUM RATINGS⁽¹⁾⁽²⁾

Over operating free-air temperature range, unless otherwise noted.

PARAMETER		TLC59281	UNIT
V _{CC}	Supply voltage: V _{CC}	-0.3 to +6.0	V
I _{OUT}	Output current (dc) OUT0 to OUT15	40	mA
V _{IN}	Input voltage range SIN, SCLK, LAT, BLANK, IREF	-0.3 to V _{CC} + 0.3	V
V _{OUT}	Output voltage range SOUT	-0.3 to V _{CC} + 0.3	V
	OUT0 to OUT15	-0.3 to +18	V
T _{J(MAX)}	Operating junction temperature	+150	°C
T _{STG}	Storage temperature range	-55 to +150	°C
ESD rating	Human body model (HBM)	2	kV
	Charged device model (CDM)	500	V

- (1) Stresses above these ratings may cause permanent damage. Exposure to absolute maximum conditions for extended periods may degrade device reliability. These are stress ratings only, and functional operation of the device at these or any other conditions beyond those specified is not supported.
- (2) All voltage values are with respect to network ground terminal.

DISSIPATION RATINGS

PACKAGE	OPERATING FACTOR ABOVE T _A = +25°C	T _A < +25°C POWER RATING	T _A = +70°C POWER RATING	T _A = +85°C POWER RATING
SSOP-24/QSOP-24	14.3 mW/°C	1782 mW	1140 mW	927 mW
QFN-24 ⁽¹⁾	24.8 mW/°C	3106 mW	1988 mW	1615 mW

(1) The package thermal impedance is calculated in accordance with JESD51-5.

RECOMMENDED OPERATING CONDITIONS

At $T_A = -40^\circ\text{C}$ to $+85^\circ\text{C}$, unless otherwise noted.

PARAMETER	TEST CONDITIONS	TLC59281			UNIT		
		MIN	NOM	MAX			
DC Characteristics: $V_{CC} = 3\text{ V to }5.5\text{ V}$							
V_{CC}	Supply voltage		3.0		5.5	V	
V_O	Voltage applied to output		OUT0 to OUT15		17	V	
V_{IH}	High-level input voltage		$0.7 \times V_{CC}$		V_{CC}	V	
V_{IL}	Low-level input voltage		GND		$0.3 \times V_{CC}$	V	
I_{OH}	High-level output current		SOUT		-1	mA	
I_{OL}	Low-level output current		SOUT		1	mA	
I_{OLC}	Constant output sink current		OUT0 to OUT15		2	35	mA
T_A	Operating free-air temperature range				-40	+85	$^\circ\text{C}$
T_J	Operating junction temperature range				-40	+125	$^\circ\text{C}$
AC Characteristics: $V_{CC} = 3\text{ V to }5.5\text{ V}$							
f_{CLK} (SCLK)	Data shift clock frequency		SCLK			35	MHz
T_{WH0}	Pulse duration		SCLK		10		ns
T_{WL0}			SCLK		10		ns
T_{WH1}			LAT		20		ns
T_{WH2}			BLANK		20		ns
T_{WL2}			BLANK		20		ns
T_{SU0}		Setup time		SIN-SCLK \uparrow		4	
T_{SU1}			LAT \uparrow -SCLK \uparrow		100		ns
T_{H0}	Hold time		SIN-SCLK \uparrow		3		ns
T_{H1}			LAT \uparrow -SCLK \uparrow		10		ns

ELECTRICAL CHARACTERISTICS

At $V_{CC} = 3.0\text{ V}$ to 5.5 V and $T_A = -40^\circ\text{C}$ to $+85^\circ\text{C}$. Typical values at $V_{CC} = 3.3\text{ V}$ and $T_A = +25^\circ\text{C}$, unless otherwise noted.

PARAMETER		TEST CONDITIONS	TLC59281			UNIT
			MIN	TYP	MAX	
V_{OH}	High-level output voltage	$I_{OH} = -1\text{ mA}$ at SOUT	$V_{CC} - 0.4$		V_{CC}	V
V_{OL}	Low-level output voltage	$I_{OL} = 1\text{ mA}$ at SOUT	0		0.4	V
I_{IN}	Input current	$V_{IN} = V_{CC}$ or GND at SIN, SCLK, LAT, and BLANK	-1		1	μA
I_{CC1}	Supply current (V_{CC})	SIN/SCLK/LAT = low, BLANK = high, $V_{OUTn} = 1\text{ V}$, $R_{REF} = 27\text{ k}\Omega$		1	2	mA
I_{CC2}		SIN/SCLK/LAT = low, BLANK = high, $V_{OUTn} = 1\text{ V}$, $R_{REF} = 3\text{ k}\Omega$		4.5	8	mA
I_{CC3}		SIN/SCLK/LAT/BLANK = low, $V_{OUTn} = 1\text{ V}$, $R_{REF} = 3\text{ k}\Omega$		7	18	mA
I_{CC4}		SIN/SCLK/LAT/BLANK = low, $V_{OUTn} = 1\text{ V}$, $R_{REF} = 1.5\text{ k}\Omega$		16	40	mA
I_{OLC}	Constant output current	All $OUTn = \text{ON}$, $V_{OUTn} = V_{OUTfix} = 1\text{ V}$, $R_{REF} = 1.5\text{ k}\Omega$ (see Figure 6), at $OUT0$ to $OUT15$	31	34	37	mA
I_{OLKG}	Output leakage current	All $OUTn$ for constant-current driver, all outputs off BLANK = high, $V_{OUTn} = V_{OUTfix} = 17\text{ V}$, $R_{REF} = 1.5\text{ k}\Omega$ (see Figure 6), at $OUT0$ to $OUT15$			0.1	μA
ΔI_{OLC}	Constant-current error (channel-to-channel) ⁽¹⁾	All $OUTn = \text{ON}$, $V_{OUTn} = V_{OUTfix} = 1\text{ V}$, $R_{REF} = 1.5\text{ k}\Omega$ at $OUT0$ to $OUT15$		± 1	± 3	%
ΔI_{OLC1}	Constant-current error (device-to-device) ⁽²⁾	All $OUTn = \text{ON}$, $V_{OUTn} = V_{OUTfix} = 1\text{ V}$, $R_{REF} = 1.5\text{ k}\Omega$ at $OUT0$ to $OUT15$		± 1	± 6	%
ΔI_{OLC2}	Line regulation ⁽³⁾	All $OUTn = \text{ON}$, $V_{OUTn} = V_{OUTfix} = 1\text{ V}$, $R_{REF} = 1.5\text{ k}\Omega$ at $OUT0$ to $OUT15$		± 0.5	± 1	%/V
ΔI_{OLC3}	Load regulation ⁽⁴⁾	All $OUTn = \text{ON}$, $V_{OUTn} = 1\text{ V}$ to 3 V , $V_{OUTfix} = 1\text{ V}$, $R_{REF} = 1.5\text{ k}\Omega$, at $OUT0$ to $OUT15$		± 1	± 3	%/V
V_{IREF}	Reference voltage output	$R_{REF} = 1.5\text{ k}\Omega$	1.16	1.20	1.24	V

(1) The deviation of each output from the average of $OUT0$ – $OUT15$ constant-current. Deviation is calculated by the formula:

$$\Delta (\%) = \left[\frac{I_{OUTn}}{\frac{(I_{OUT0} + I_{OUT1} + \dots + I_{OUT14} + I_{OUT15})}{16}} - 1 \right] \times 100$$

(2) The deviation of the $OUT0$ – $OUT15$ constant-current average from the ideal constant-current value. Deviation is calculated by the following formula:

$$\Delta (\%) = \left[\frac{\frac{(I_{OUT0} + I_{OUT1} + \dots + I_{OUT14} + I_{OUT15})}{16} - (\text{Ideal Output Current})}{\text{Ideal Output Current}} \right] \times 100$$

Ideal current is calculated by the formula:

$$I_{OUT(\text{IDEAL})} = 42 \times \left[\frac{1.20}{R_{REF}} \right]$$

(3) Line regulation is calculated by this equation:

$$\Delta (\%/V) = \left[\frac{(I_{OUTn} \text{ at } V_{CC} = 5.5\text{ V}) - (I_{OUTn} \text{ at } V_{CC} = 3.0\text{ V})}{(I_{OUTn} \text{ at } V_{CC} = 3.0\text{ V})} \right] \times \frac{100}{5.5\text{ V} - 3\text{ V}}$$

(4) Load regulation is calculated by the equation:

$$\Delta (\%/V) = \left[\frac{(I_{OUTn} \text{ at } V_{OUTn} = 3\text{ V}) - (I_{OUTn} \text{ at } V_{OUTn} = 1\text{ V})}{(I_{OUTn} \text{ at } V_{OUTn} = 1\text{ V})} \right] \times \frac{100}{3\text{ V} - 1\text{ V}}$$

SWITCHING CHARACTERISTICS

At $V_{CC} = 3.0\text{ V to }5.5\text{ V}$, $T_A = -40^\circ\text{C to }+85^\circ\text{C}$, $C_L = 15\text{ pF}$, $R_L = 130\ \Omega$, $R_{IREF} = 1.5\text{ k}\Omega$, and $V_{LED} = 5.5\text{ V}$. Typical values at $V_{CC} = 3.3\text{ V}$ and $T_A = +25^\circ\text{C}$, unless otherwise noted.

PARAMETER	TEST CONDITIONS	TLC59281			UNIT	
		MIN	TYP	MAX		
t_{R0}	Rise time	SOUT (see Figure 5)		5	15	ns
t_{R1}		OUTn (see Figure 4)		10	30	ns
t_{F0}	Fall time	SOUT (see Figure 5)		5	15	ns
t_{F1}		OUTn (see Figure 4)		10	30	ns
t_{D0}	Propagation delay time	SCLK \uparrow to SOUT		8	20	ns
t_{D1}		LAT \uparrow or BLANK \downarrow to OUTn sink current on (see Figure 10)		12	30	ns
t_{D2}		LAT \uparrow or BLANK \uparrow to OUTn sink current off (see Figure 10)		12	30	ns
t_{ON_ERR}	Output on-time error ⁽¹⁾	On/off latch data = all '1', 20 ns BLANK low level one-shot pulse input (see Figure 4)		-8	+8	ns

(1) Output on-time error (t_{ON_ERR}) is calculated by the formula: t_{ON_ERR} (ns) = t_{OUT_ON} – BLANK low level one-shot pulse width (T_{WL2}). t_{OUT_ON} indicates the actual on-time of the constant-current driver.

FUNCTIONAL BLOCK DIAGRAM

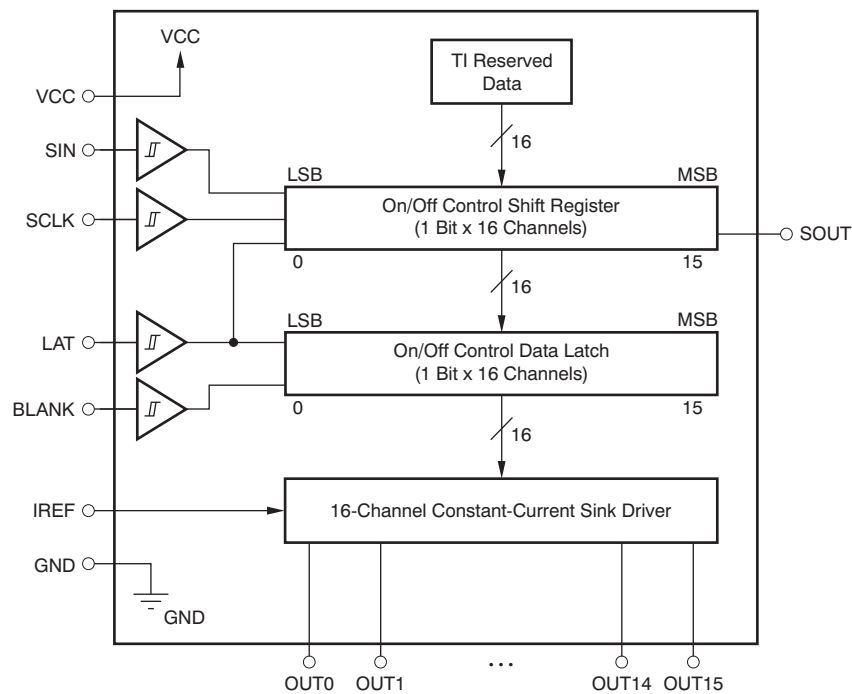

DEVICE INFORMATION

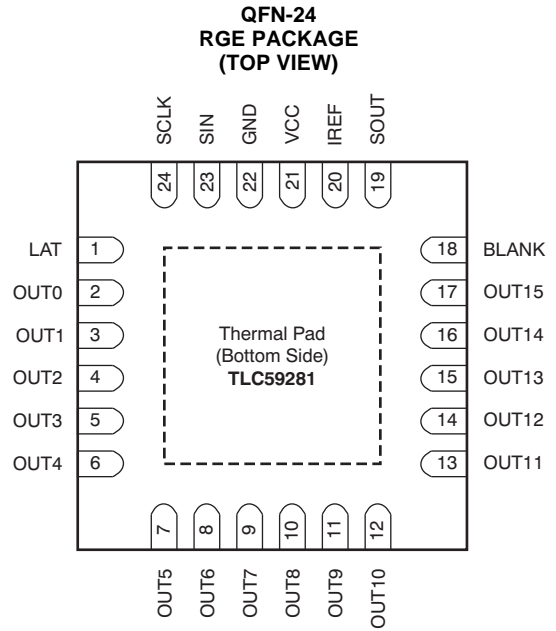
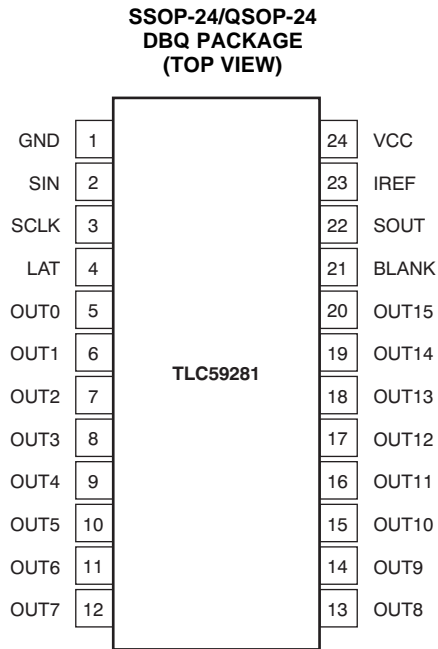

NOTE: Thermal pad is not connected to GND internally. The thermal pad must be connected to GND via the PCB pattern.

TERMINAL FUNCTIONS

TERMINAL			I/O	DESCRIPTION
NAME	DBQ	RGE		
SIN	2	23	I	Serial data input for driver on/off control. When SIN = high level, data '1' are written into LSB of the on/off control shift register at the rising edge of SCLK.
SCLK	3	24	I	Serial data shift clock. Schmitt buffer input. All data in the on/off control shift register are shifted toward the MSB by 1-bit synchronization of SCLK. A rising edge on SCLK is allowed 100 ns after a rising edge of LAT.
LAT	4	1	I	Edge triggered latch. The data in the on/off control data shift register are transferred to the on/off control data latch at this rising edge. At the same time, the data in the on/off control shift register are replaced with TI reserved data for production test. LAT must be toggled only once after the shift data are updated to avoid the on/off control latch data being replaced with TI reserved data in the shift register. The reserved data is not a fixed number.
BLANK	21	18	I	Blank, all outputs. When BLANK = high level, all constant-current outputs (OUT0–OUT15) are forced off. When BLANK = low level, all constant-current outputs are controlled by the on/off control data in the data latch.
IREF	23	20	I/O	Constant-current value setting, OUT0–OUT15 sink constant-current is set to desired value by connection to an external resistor between IREF and GND.
SOUT	22	19	O	Serial data output. This output is connected to the MSB of the on/off data shift register. SOUT data changes at the rising edge of SCLK.
OUT0	5	2	O	Constant-current output. Each output can be tied together with others to increase the constant-current. Different voltages can be applied to each output.
OUT1	6	3	O	Constant-current output
OUT2	7	4	O	Constant-current output
OUT3	8	5	O	Constant-current output
OUT4	9	6	O	Constant-current output
OUT5	10	7	O	Constant-current output
OUT6	11	8	O	Constant-current output
OUT7	12	9	O	Constant-current output
OUT8	13	10	O	Constant-current output
OUT9	14	11	O	Constant-current output
OUT10	15	12	O	Constant-current output
OUT11	16	13	O	Constant-current output
OUT12	17	14	O	Constant-current output
OUT13	18	15	O	Constant-current output
OUT14	19	16	O	Constant-current output
OUT15	20	17	O	Constant-current output
VCC	24	21	—	Power-supply voltage
GND	1	22	—	Power ground

PARAMETER MEASUREMENT INFORMATION

PIN EQUIVALENT INPUT AND OUTPUT SCHEMATIC DIAGRAMS

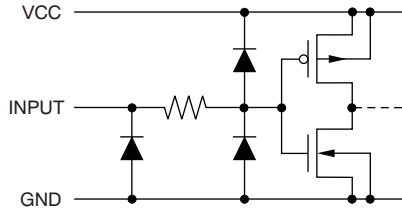

Figure 1. SIN, SCLK, LAT, BLANK

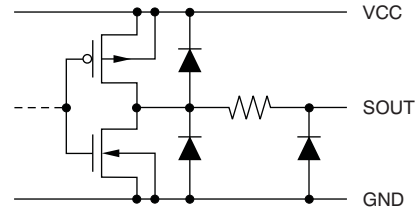

Figure 2. SOUT

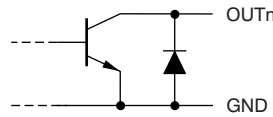
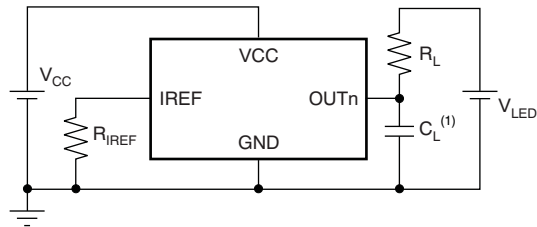

Figure 3. OUT0 Through OUT15

TEST CIRCUITS



(1) C_L includes measurement probe and jig capacitance.

Figure 4. Rise Time and Fall Time Test Circuit for OUTn

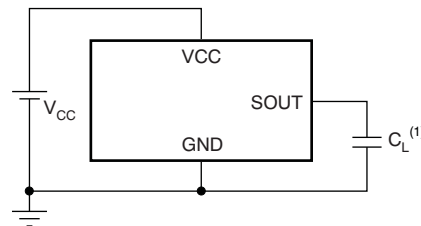

(1) C_L includes measurement probe and jig capacitance.

Figure 5. Rise Time and Fall Time Test Circuit for SOUT

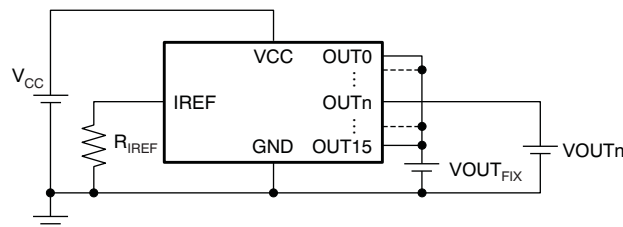
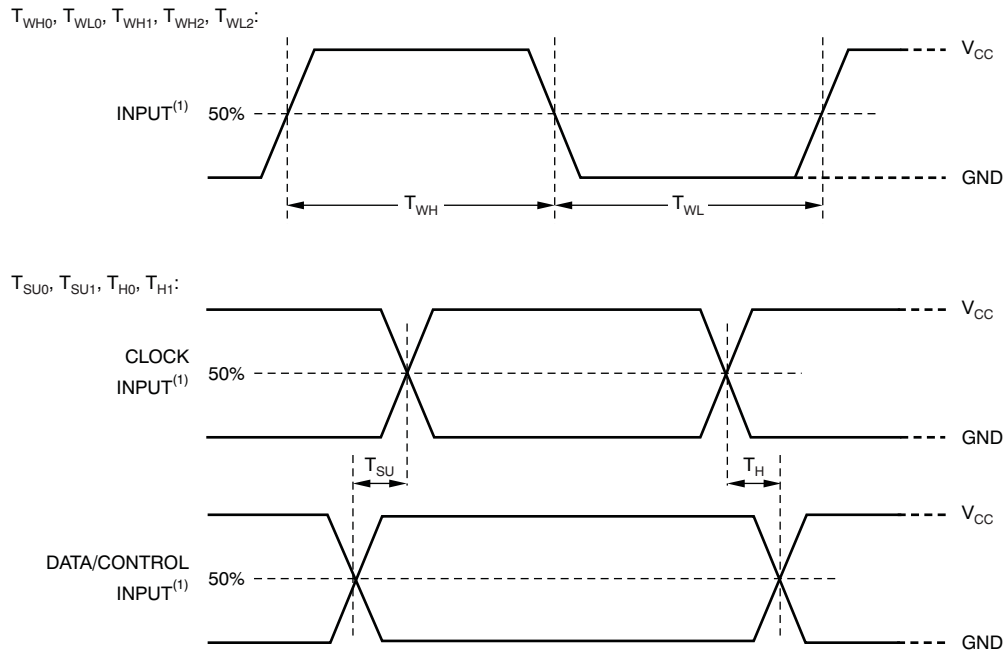

Figure 6. Constant-Current Test Circuit for OUTn

TIMING DIAGRAMS



(1) Input pulse rise and fall time is 1 ns to 3 ns.

Figure 7. Input Timing

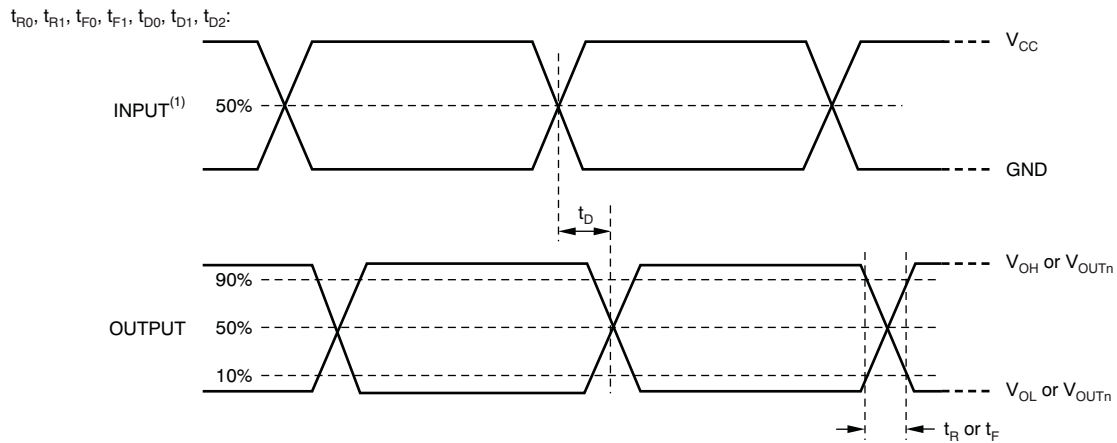

(1) Input pulse rise and fall time is 1 ns to 3 ns.

Figure 8. Output Timing

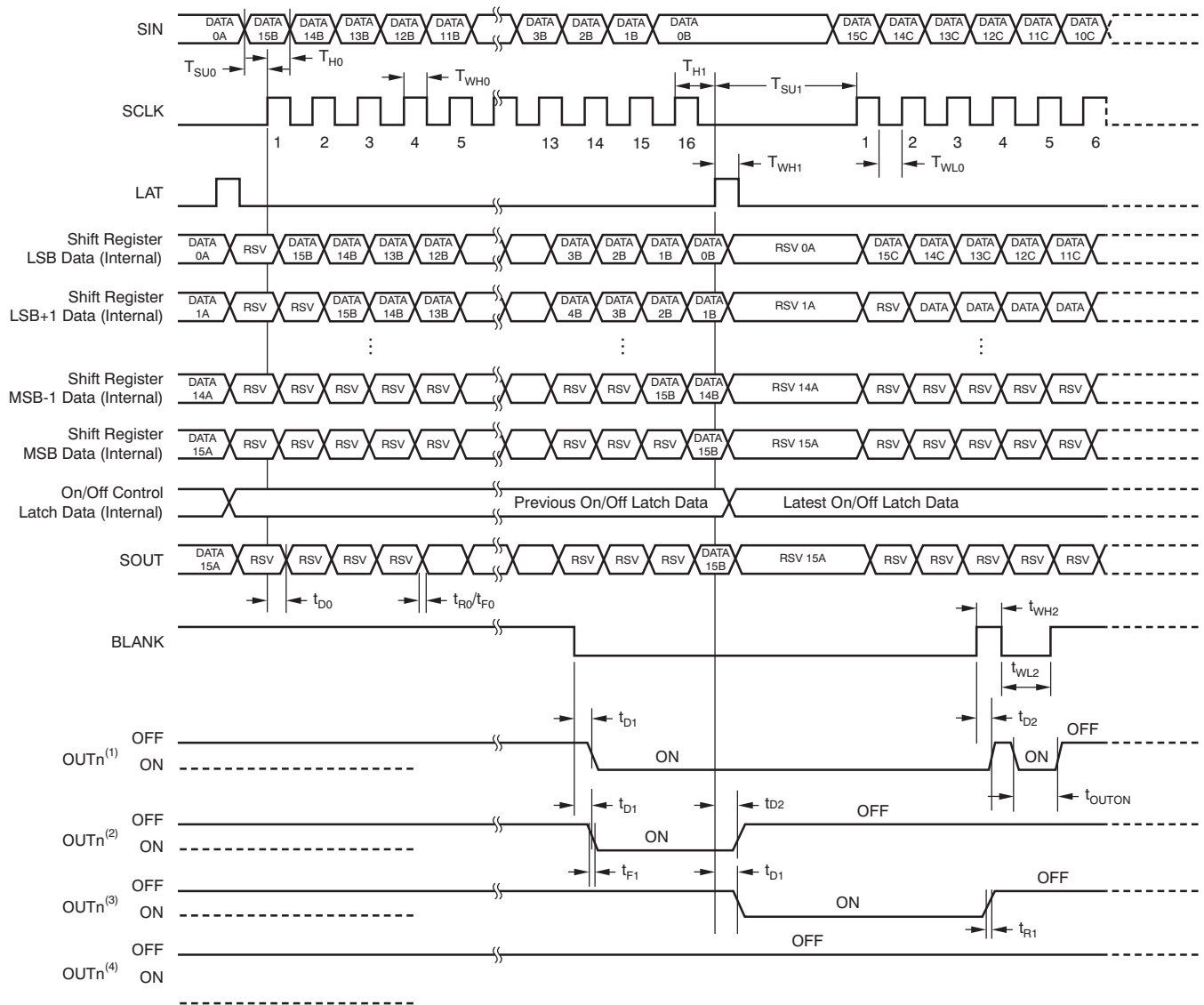

- (1) On/off latched data are '1'.
- (2) On/off latched data are changed from '1' to '0' at the second LAT signal.
- (3) On/off latched data are changed from '0' to '1' at the second LAT signal.
- (4) On/off latched data are '0'.

Figure 9. Timing Diagram

TYPICAL CHARACTERISTICS

At $V_{CC} = 3.3\text{ V}$ and $T_A = +25^\circ\text{C}$, unless otherwise noted.

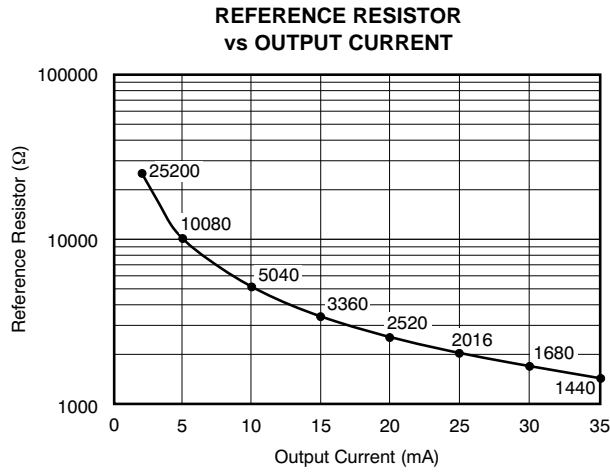

Figure 10.

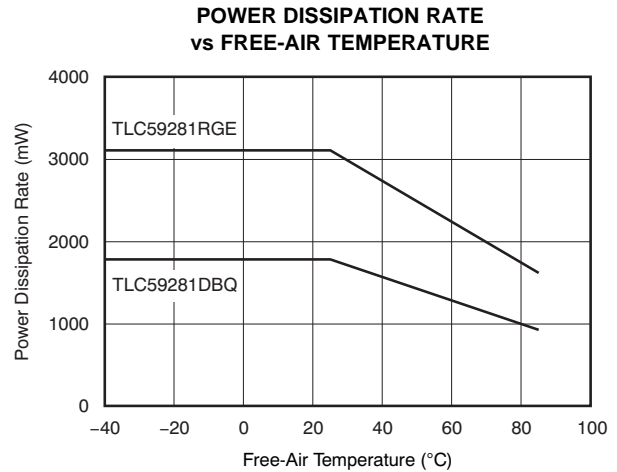

Figure 11.

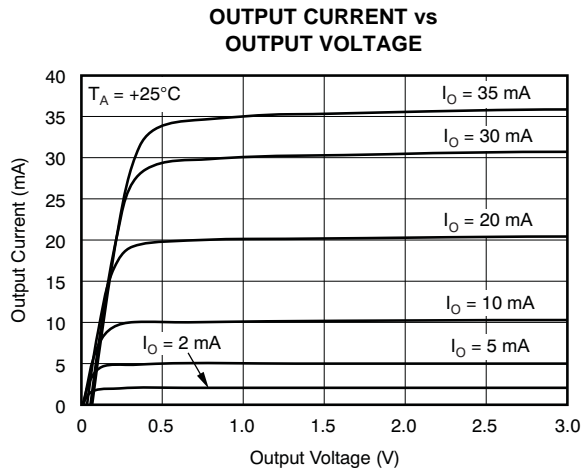

Figure 12.

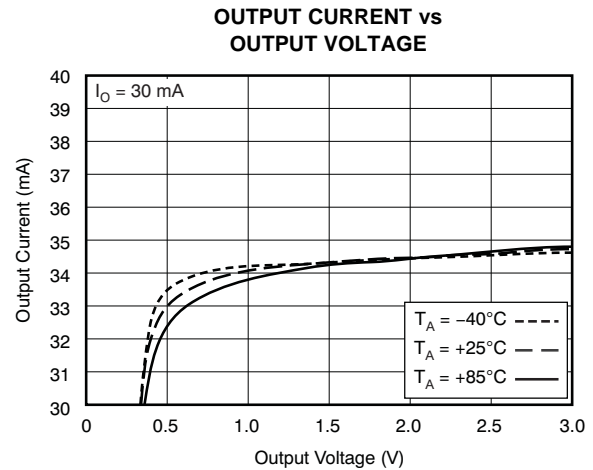

Figure 13.

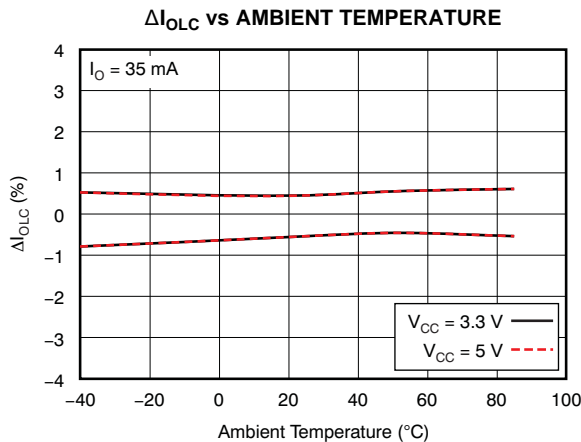

Figure 14.

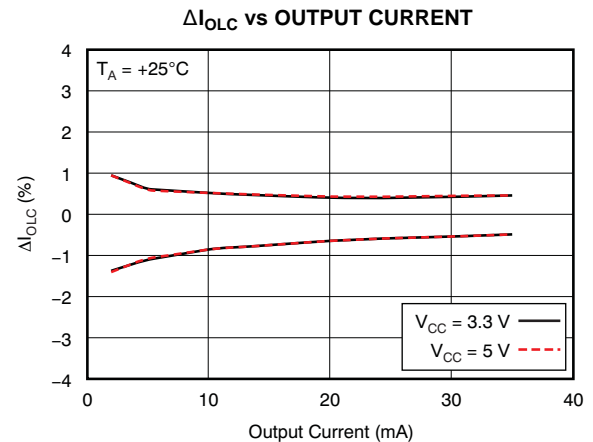
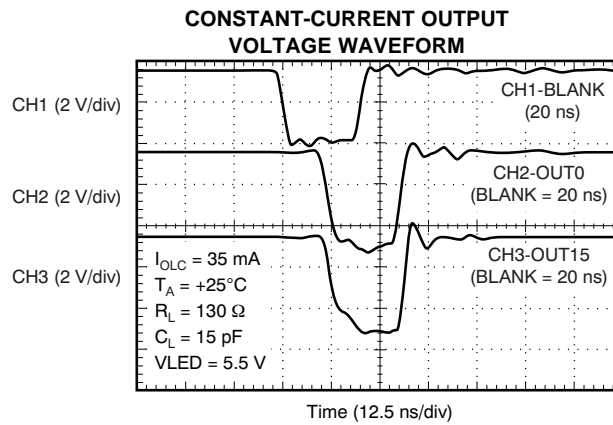

Figure 15.

TYPICAL CHARACTERISTICS (continued)At $V_{CC} = 3.3\text{ V}$ and $T_A = +25^\circ\text{C}$, unless otherwise noted.**Figure 16.**

DETAILED DESCRIPTION

SETTING FOR THE CONSTANT SINK CURRENT VALUE

The constant-current values are determined by an external resistor (R_{IREF}) placed between IREF and GND. The resistor (R_{IREF}) value is calculated by [Equation 1](#).

$$R_{IREF} \text{ (k}\Omega\text{)} = \frac{V_{IREF} \text{ (V)}}{I_{OLC} \text{ (mA)}} \times 42$$

Where:

$$V_{IREF} = \text{the internal reference voltage on the IREF pin (typically 1.20 V)} \quad (1)$$

I_{OLC} must be set in the range of 2 mA to 35 mA. The constant sink current characteristic for the external resistor value is shown in [Figure 10](#). [Table 1](#) describes the constant-current output versus external resistor value.

Table 1. Constant-Current Output versus External Resistor Value

I_{OLCMax} (mA, Typical)	R_{IREF} (k Ω)
35	1.44
30	1.68
25	2.02
20	2.52
15	3.36
10	5.04
5	10.1
2	25.2

CONSTANT-CURRENT DRIVER ON/OFF CONTROL

When BLANK is low, the corresponding output is turned on if the data in the on/off control data latch are '1' and remains off if the data are '0'. When BLANK is high, all outputs are forced off. This control is shown in [Table 2](#).

Table 2. On/Off Control Data Truth Table

ON/OFF CONTROL LATCH DATA	CONSTANT-CURRENT OUTPUT STATUS
0	Off
1	On

When the IC is initially powered on, the data in the on/off control shift register and data latch are not set to the respective default value. Therefore, the on/off control data must be written to the data latch before turning the constant-current output on. BLANK should be at a high level when powered on because the constant-current may be turned on as a result of random data in the on/off control latch.

The on/off data corresponding to any unconnected OUTn outputs should be set to '0' before turning on the remaining outputs. Otherwise, the supply current (I_{CC}) increases while the LEDs are on.

REGISTER CONFIGURATION

The TLC59281 has an on/off control data shift register and data latch. Both the on/off control shift register and latch are 16 bits long and are used to turn the constant-current drivers on and off. Figure 17 shows the shift register and latch configuration. The data at the SIN pin is shifted in to the LSB of the shift register at the rising edge of the SCLK pin; SOUT data change at the rising edge of SCLK. The timing diagram for data writing is shown in Figure 18. The driver on/off is controlled by the data in the on/off control data latch.

The on/off data are latched into the data latch by a rising edge of LAT after the data are written into the on/off control shift register by SIN and SCLK. At the same time, the data in the on/off control shift register are replaced with TI reserved data for production test. Therefore, LAT must be input only once after the on/off data update to avoid the on/off control data latch being replaced with TI reserved data in the shift register. When the IC initially powers on, the data in the on/off control shift register and latch are not set to the default values; on/off control data must be written to the on/off control data latch before turning the constant-current output on. BLANK should be high when the IC is powered on because the constant-current may be turned on at that time as a result of random values in the on/off data latch. All constant-current outputs are forced off when BLANK is high.

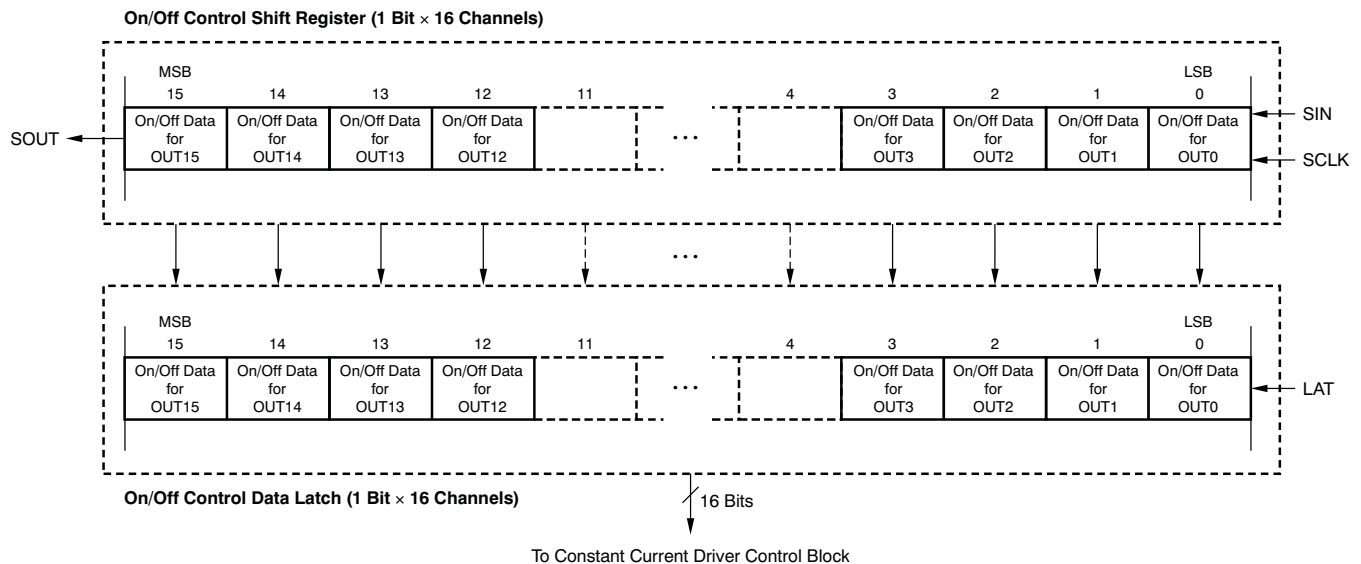
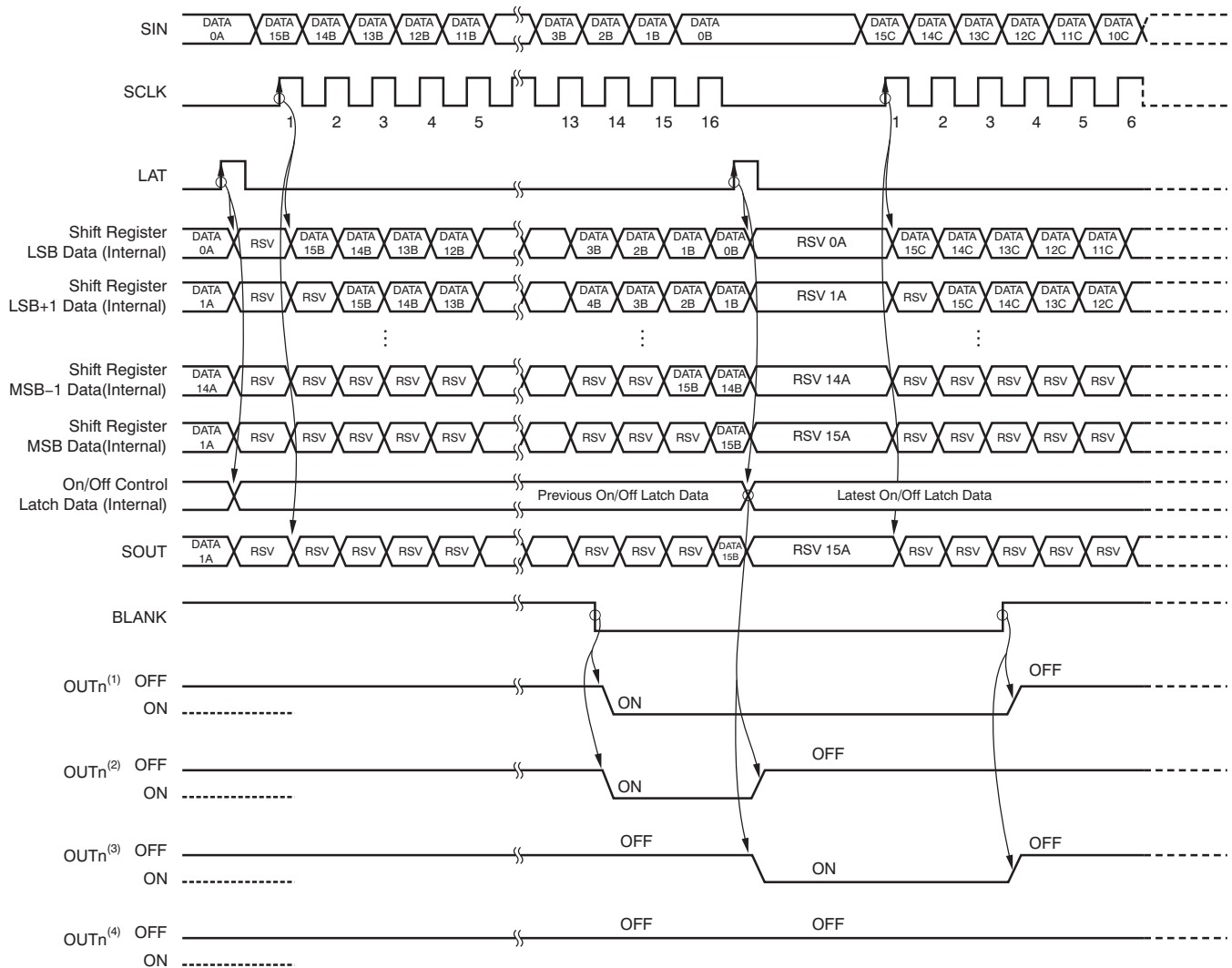

Figure 17. On/Off Control Shift Register and Latch Configuration



- (1) On/off latched data are '1'.
- (2) On/off latched data are changed from '1' to '0' at the second LAT signal.
- (3) On/off latched data are changed from '0' to '1' at the second LAT signal.
- (4) On/off latched data are '0'.

Figure 18. On/Off Control Operation

LAYOUT CONSIDERATIONS

The output current transient time in the TLC59281 is very fast. In addition, all outputs turn on or off at the same time to minimize the output on-time error. This high current demand can cause GND to shift in the entire system, and lead to false triggering of signals. To overcome this issue, design all GND lines to be as wide and short as possible in order to reduce parasitic inductance and resistance.

REVISION HISTORY

NOTE: Page numbers for previous revisions may differ from page numbers in the current version.

Changes from Revision A (September 2010) to Revision B	Page
• Added <i>Layout Considerations</i> section	15

Changes from Original (January 2010) to Revision A	Page
• Changed SO-24 to SSOP-24/QSOP-24 in Package/Ordering Information table	2
• Changed SO-24 to SSOP-24/QSOP-24 in Dissipation Ratings table	2
• Changed SO-24 to SSOP-24/QSOP-24 in DBQ pinout	6

PACKAGING INFORMATION

Orderable Device	Status (1)	Package Type	Package Drawing	Pins	Package Qty	Eco Plan (2)	Lead finish/ Ball material (6)	MSL Peak Temp (3)	Op Temp (°C)	Device Marking (4/5)	Samples
TLC59281DBQ	ACTIVE	SSOP	DBQ	24	50	RoHS & Green	NIPDAU	Level-2-260C-1 YEAR	-40 to 85	TLC59281	Samples
TLC59281DBQR	ACTIVE	SSOP	DBQ	24	2500	RoHS & Green	NIPDAU	Level-2-260C-1 YEAR	-40 to 85	TLC59281	Samples
TLC59281RGER	ACTIVE	VQFN	RGE	24	3000	RoHS & Green	NIPDAU	Level-2-260C-1 YEAR	-40 to 85	TLC 59281	Samples
TLC59281RGET	ACTIVE	VQFN	RGE	24	250	RoHS & Green	NIPDAU	Level-2-260C-1 YEAR		TLC 59281	Samples

(1) The marketing status values are defined as follows:

ACTIVE: Product device recommended for new designs.

LIFEBUY: TI has announced that the device will be discontinued, and a lifetime-buy period is in effect.

NRND: Not recommended for new designs. Device is in production to support existing customers, but TI does not recommend using this part in a new design.

PREVIEW: Device has been announced but is not in production. Samples may or may not be available.

OBSOLETE: TI has discontinued the production of the device.

(2) **RoHS:** TI defines "RoHS" to mean semiconductor products that are compliant with the current EU RoHS requirements for all 10 RoHS substances, including the requirement that RoHS substance do not exceed 0.1% by weight in homogeneous materials. Where designed to be soldered at high temperatures, "RoHS" products are suitable for use in specified lead-free processes. TI may reference these types of products as "Pb-Free".

RoHS Exempt: TI defines "RoHS Exempt" to mean products that contain lead but are compliant with EU RoHS pursuant to a specific EU RoHS exemption.

Green: TI defines "Green" to mean the content of Chlorine (Cl) and Bromine (Br) based flame retardants meet JS709B low halogen requirements of <=1000ppm threshold. Antimony trioxide based flame retardants must also meet the <=1000ppm threshold requirement.

(3) MSL, Peak Temp. - The Moisture Sensitivity Level rating according to the JEDEC industry standard classifications, and peak solder temperature.

(4) There may be additional marking, which relates to the logo, the lot trace code information, or the environmental category on the device.

(5) Multiple Device Markings will be inside parentheses. Only one Device Marking contained in parentheses and separated by a "~" will appear on a device. If a line is indented then it is a continuation of the previous line and the two combined represent the entire Device Marking for that device.

(6) Lead finish/Ball material - Orderable Devices may have multiple material finish options. Finish options are separated by a vertical ruled line. Lead finish/Ball material values may wrap to two lines if the finish value exceeds the maximum column width.

Important Information and Disclaimer:The information provided on this page represents TI's knowledge and belief as of the date that it is provided. TI bases its knowledge and belief on information provided by third parties, and makes no representation or warranty as to the accuracy of such information. Efforts are underway to better integrate information from third parties. TI has taken and

continues to take reasonable steps to provide representative and accurate information but may not have conducted destructive testing or chemical analysis on incoming materials and chemicals. TI and TI suppliers consider certain information to be proprietary, and thus CAS numbers and other limited information may not be available for release.

In no event shall TI's liability arising out of such information exceed the total purchase price of the TI part(s) at issue in this document sold by TI to Customer on an annual basis.

TAPE AND REEL INFORMATION

QUADRANT ASSIGNMENTS FOR PIN 1 ORIENTATION IN TAPE



*All dimensions are nominal

Device	Package Type	Package Drawing	Pins	SPQ	Reel Diameter (mm)	Reel Width W1 (mm)	A0 (mm)	B0 (mm)	K0 (mm)	P1 (mm)	W (mm)	Pin1 Quadrant
TLC59281DBQR	SSOP	DBQ	24	2500	330.0	16.4	6.5	9.0	2.1	8.0	16.0	Q1
TLC59281RGER	VQFN	RGE	24	3000	330.0	12.4	4.25	4.25	1.15	8.0	12.0	Q2
TLC59281RGET	VQFN	RGE	24	250	180.0	12.4	4.25	4.25	1.15	8.0	12.0	Q2

TAPE AND REEL BOX DIMENSIONS

*All dimensions are nominal

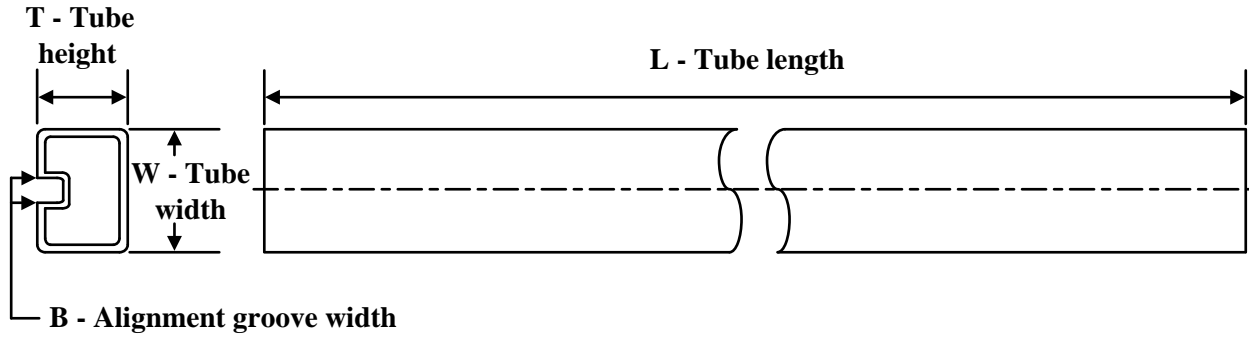
Device	Package Type	Package Drawing	Pins	SPQ	Length (mm)	Width (mm)	Height (mm)
TLC59281DBQR	SSOP	DBQ	24	2500	356.0	356.0	35.0
TLC59281RGER	VQFN	RGE	24	3000	356.0	356.0	35.0
TLC59281RGET	VQFN	RGE	24	250	210.0	185.0	35.0

TUBE

*All dimensions are nominal

Device	Package Name	Package Type	Pins	SPQ	L (mm)	W (mm)	T (μm)	B (mm)
TLC59281DBQ	DBQ	SSOP	24	50	506.6	8	3940	4.32

DBQ (R-PDSO-G24)

PLASTIC SMALL-OUTLINE PACKAGE

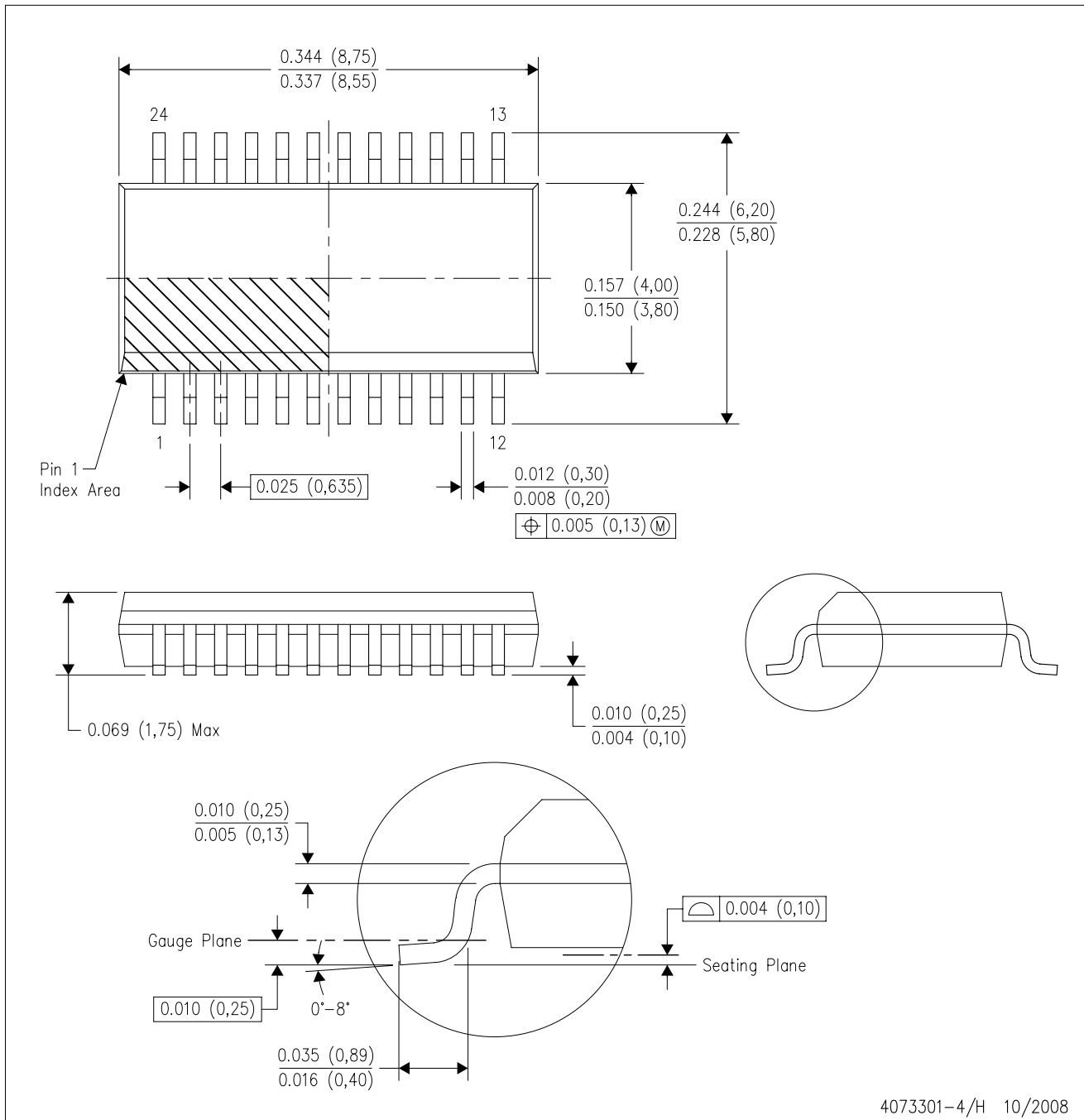

- NOTES:
- A. All linear dimensions are in inches (millimeters).
 - B. This drawing is subject to change without notice.
 - C. Body dimensions do not include mold flash or protrusion not to exceed 0.006 (0,15) per side.
 - D. Falls within JEDEC MO-137 variation AE.

RGE 24

GENERIC PACKAGE VIEW

VQFN - 1 mm max height

PLASTIC QUAD FLATPACK - NO LEAD

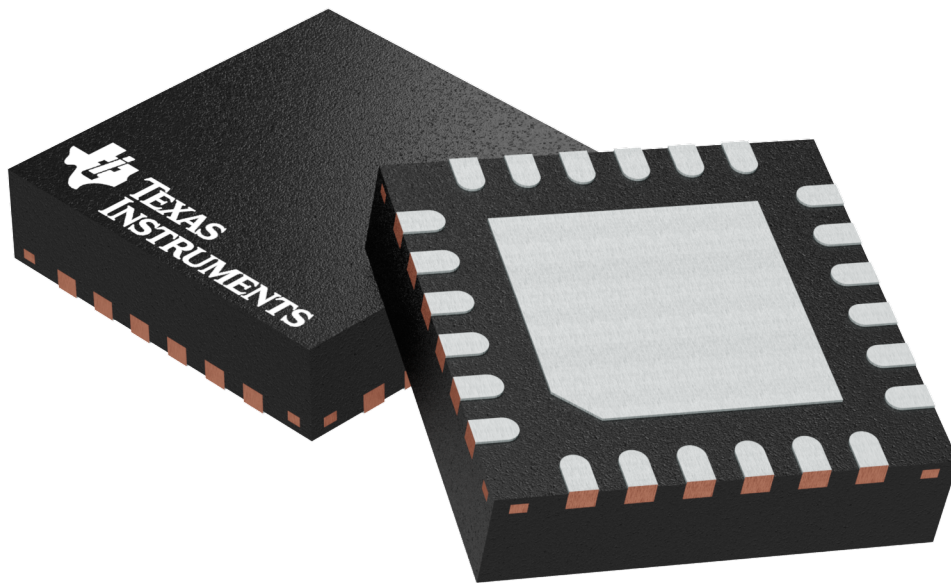

Images above are just a representation of the package family, actual package may vary.
Refer to the product data sheet for package details.

4204104/H

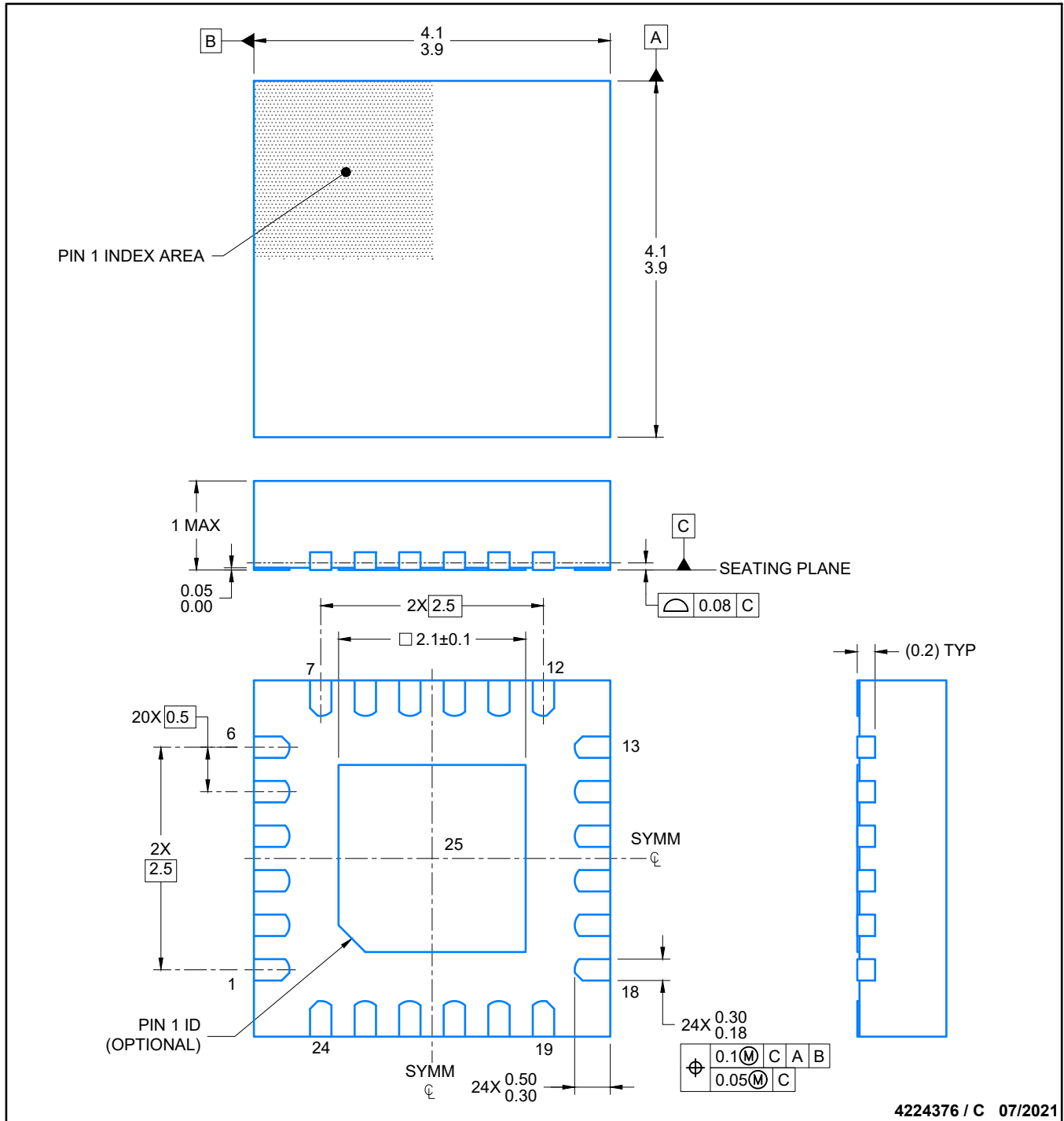

NOTES:

1. All linear dimensions are in millimeters. Any dimensions in parenthesis are for reference only. Dimensioning and tolerancing per ASME Y14.5M.
2. This drawing is subject to change without notice.
3. The package thermal pad must be soldered to the printed circuit board for thermal and mechanical performance.

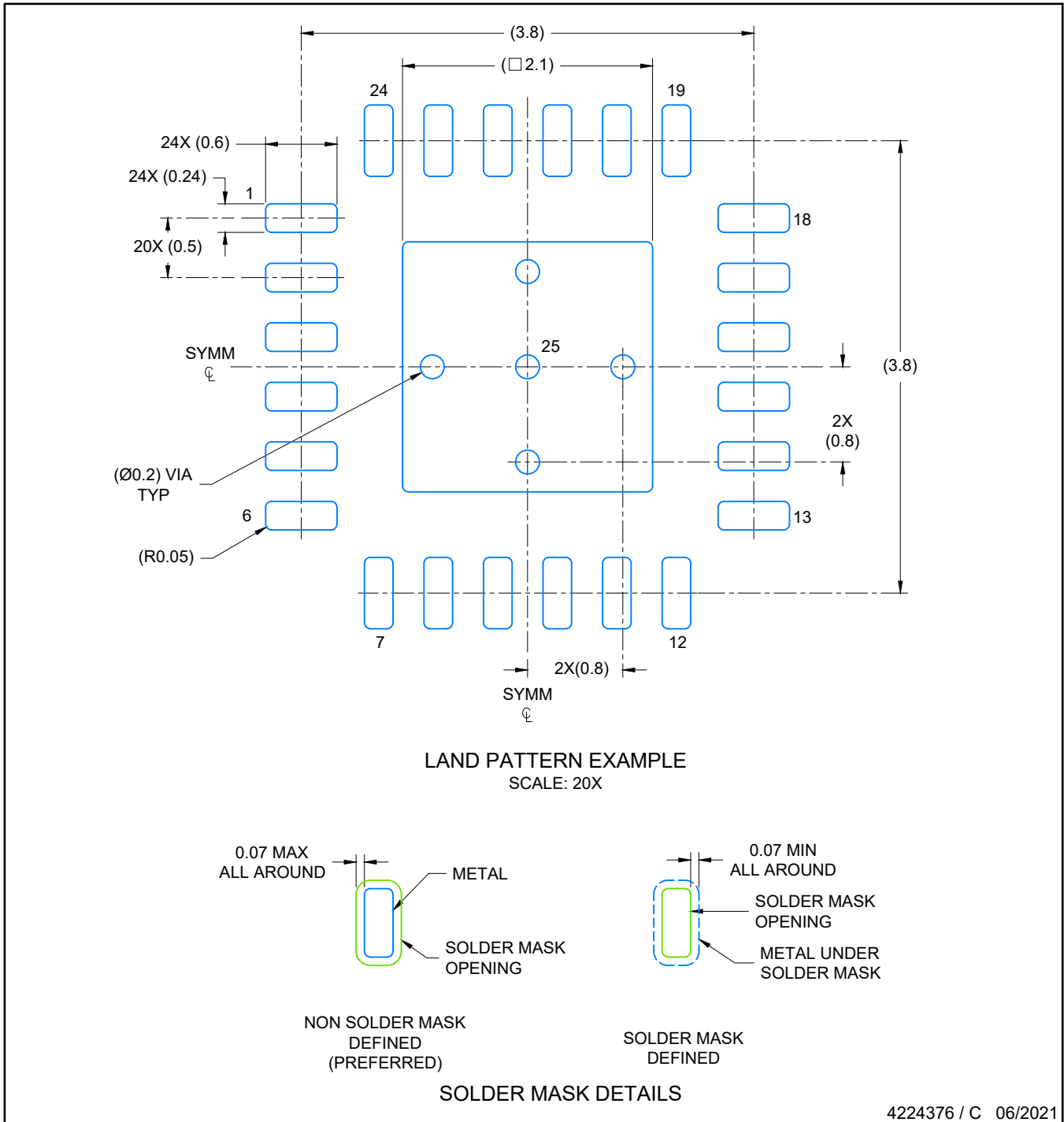

4224376 / C 06/2021

NOTES: (continued)

4. This package is designed to be soldered to a thermal pad on the board. For more information, see Texas Instruments literature number SLUA271 (www.ti.com/lit/slua271).
5. Solder mask tolerances between and around signal pads can vary based on board fabrication site.

EXAMPLE STENCIL DESIGN

RGE0024C

VQFN - 1 mm max height

PLASTIC QUAD FLATPACK- NO LEAD

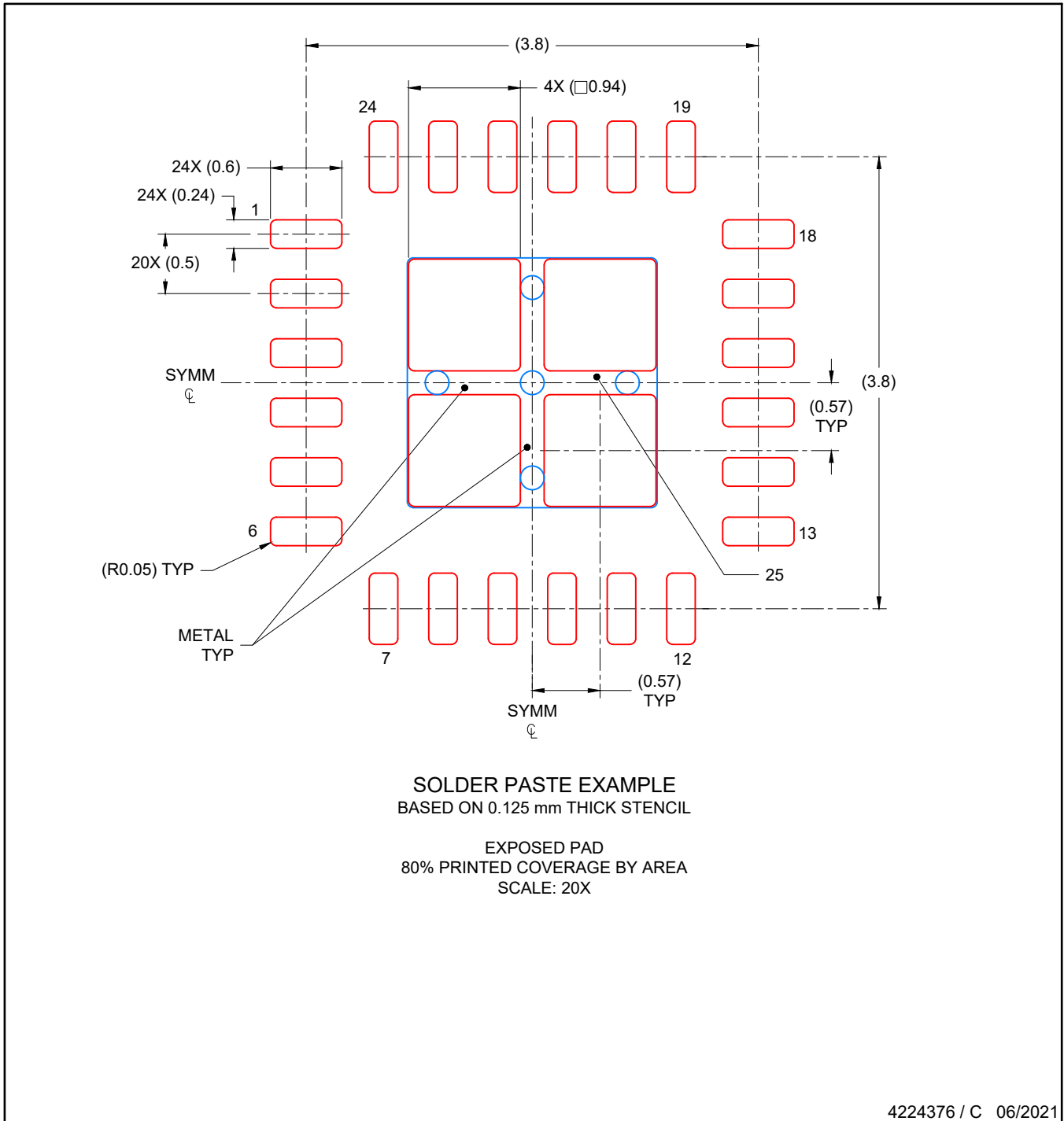

NOTES: (continued)

6. Laser cutting apertures with trapezoidal walls and rounded corners may offer better paste release. IPC-7525 may have alternate design recommendations..

IMPORTANT NOTICE AND DISCLAIMER

TI PROVIDES TECHNICAL AND RELIABILITY DATA (INCLUDING DATA SHEETS), DESIGN RESOURCES (INCLUDING REFERENCE DESIGNS), APPLICATION OR OTHER DESIGN ADVICE, WEB TOOLS, SAFETY INFORMATION, AND OTHER RESOURCES "AS IS" AND WITH ALL FAULTS, AND DISCLAIMS ALL WARRANTIES, EXPRESS AND IMPLIED, INCLUDING WITHOUT LIMITATION ANY IMPLIED WARRANTIES OF MERCHANTABILITY, FITNESS FOR A PARTICULAR PURPOSE OR NON-INFRINGEMENT OF THIRD PARTY INTELLECTUAL PROPERTY RIGHTS.

These resources are intended for skilled developers designing with TI products. You are solely responsible for (1) selecting the appropriate TI products for your application, (2) designing, validating and testing your application, and (3) ensuring your application meets applicable standards, and any other safety, security, regulatory or other requirements.

These resources are subject to change without notice. TI grants you permission to use these resources only for development of an application that uses the TI products described in the resource. Other reproduction and display of these resources is prohibited. No license is granted to any other TI intellectual property right or to any third party intellectual property right. TI disclaims responsibility for, and you will fully indemnify TI and its representatives against, any claims, damages, costs, losses, and liabilities arising out of your use of these resources.

TI's products are provided subject to [TI's Terms of Sale](#) or other applicable terms available either on ti.com or provided in conjunction with such TI products. TI's provision of these resources does not expand or otherwise alter TI's applicable warranties or warranty disclaimers for TI products.

TI objects to and rejects any additional or different terms you may have proposed.

Mailing Address: Texas Instruments, Post Office Box 655303, Dallas, Texas 75265
Copyright © 2022, Texas Instruments Incorporated

Looking for pricing, stock, or lifecycle information?

Click below to explore more details on WIN SOURCE:

 [View TLC59281DBQR on WIN SOURCE](#)

 [Texas Instruments](#) Information

Optimize Your Supply Chain with WIN SOURCE Solutions

-  Global Sourcing Solution
-  Obsolete Management
-  Cost Control Management
-  Shortage Management
-  Alternative Solution
-  Excess Inventory Management