



**THE DATASHEET OF
TLC320AD545IPT**



TLC320A545C/I
Single Channel Data/Fax Codec

Data Manual

Contents

<i>Section</i>	<i>Title</i>	<i>Page</i>
1	Introduction	1–1
1.1	Features	1–1
1.2	Functional Block Diagram	1–2
1.3	Analog Block Diagram	1–2
1.4	Terminal Assignments	1–3
1.5	Ordering Information	1–3
1.6	Terminal Functions	1–3
2	Functional Description	2–1
2.1	Device Requirements and System Overview	2–1
2.2	Codec Functions	2–1
2.3	Hybrid Functions	2–1
2.4	Miscellaneous Logic and Other Circuitry	2–1
3	Codec Functional Description	3–1
3.1	Operating Frequencies	3–1
3.2	ADC Signal Channel	3–1
3.3	DAC Signal Channel	3–1
3.4	Sigma-Delta ADC	3–1
3.5	Decimation Filter	3–1
3.6	Sigma-Delta DAC	3–1
3.7	Interpolation Filter	3–2
3.8	Analog and Digital Loopbacks	3–2
3.9	Software Power Down	3–2
3.10	Test Module	3–2
3.11	Power Supply Options	3–2
4	Serial Communications	4–1
4.1	Primary Serial Communication	4–1
4.1.1	FS High Mode Primary Communication Timing	4–2
4.1.2	FS Low Mode Primary Communication Timing	4–2
4.2	Secondary Serial Communication	4–3
4.3	FS High Mode Secondary Communication Timing	4–4
4.4	FS Low Mode Secondary Communication Timing	4–4
5	Specifications	5–1
5.1	Absolute Maximum Ratings Over Operating Free-Air Temperature Range	5–1
5.2	Recommended Operating Conditions	5–1
5.3	Electrical Characteristics Over Recommended Operating Free-Air Temperature Range $DV_{DD} = 5\text{ V}/3.3\text{ V}$, $AV_{DD} = 5\text{ V}/3.3\text{ V}$, $MV_{DD} = 5\text{ V}/3.3\text{ V}$	5–2

5.3.1	Digital Inputs and Outputs, $f_S = 8$ kHz, Outputs Not Loaded	5-2
5.3.2	ADC Channel, $f_S = 8$ kHz	5-2
5.3.3	ADC Dynamic Performance, $f_S = 8$ kHz	5-2
5.3.3.1	ADC Signal-to-Noise	5-2
5.3.3.2	ADC Signal-to-Distortion	5-2
5.3.3.3	ADC Signal-to-Distortion + Noise	5-3
5.3.4	ADC Characteristics	5-3
5.3.5	DAC Channel, $f_S = 8$ kHz	5-3
5.3.6	DAC Dynamic Performance	5-3
5.3.6.1	DAC Signal-to-Noise	5-3
5.3.6.2	DAC Signal-to-Distortion	5-3
5.3.6.3	DAC Signal-to-Distortion + Noise	5-4
5.3.7	DAC Characteristics	5-4
5.3.8	Logic DC Electrical Characteristics	5-4
5.3.9	Power-Supply Rejection	5-4
5.3.10	Power-Supply	5-5
5.3.11	Flash Write Enable Circuit	5-5
5.4	Timing Characteristics	5-5
5.4.1	Timing Requirements	5-5
5.4.2	Switching Characteristics	5-5
5.5	Parameter Measurement Information	5-6
6	Application Information	6-1
Appendix A	– Programmable Register Set	A-1

List of Illustrations

<i>Figure</i>	<i>Title</i>	<i>Page</i>
4-1	Primary Communication DIN and DOUT Data Format	4-1
4-2	FS High Mode Primary Serial Communication Timing	4-2
4-3	FS Low Mode Primary Serial Communication Timing	4-3
4-4	Secondary Communication DIN and DOUT Data Format	4-3
4-5	FS Output During Software Secondary Serial Communication Request (FS High Mode)	4-4
4-6	FS Output During Software Secondary Serial Communication Request (FS Low Mode)	4-4
5-1	Serial Communication Timing	5-6
5-2	ADC Decimation Filter Response	5-6
5-3	ADC Decimation Filter Passband Ripple	5-7
5-4	DAC Interpolation Filter Response	5-7
5-5	DAC Interpolation Filter Passband Ripple	5-8
6-1	Functional Block of a Typical Application	6-1
6-2	Differential Configuration Typical Application	6-2
6-3	Single-Ended Configuration Typical Application	6-3

List of Tables

<i>Table</i>	<i>Title</i>	<i>Page</i>
4-1	Least-Significant-Bit Control Function	4-3

1 Introduction

The TLC320AD545 single channel data/fax codec is a mixed signal broadband connectivity device. The TLC320AD545 is comprised of a single channel codec and analog hybrid circuitry with a serial port for communication with the host processor. The device also contains programmable gain control and one AT41 speaker driver. The device operates with either a 5-V analog, a 5-V digital, and a 5-V monitor power supply or a 3.3-V analog, a 3.3-V digital, and a 3.3-V monitor power supply or 5-V analog, 3.3-V digital, and a 5-V monitor power supply. The device will be packaged in a single 48-pin PT (TQFP) package.

1.1 Features

- Analog, Digital, and Monitor Amp Power Supplies: 5 V or 3.3 V
- Differential and Single-Ended Driving of Analog Output
- Software Power-Down Mode
- Sample Rate Up to 11.025 kHz
- 16-Bit Signal Processing in the Codec With 2s-Complement Data Format
- Typical 80-db Dynamic Range
- Total Signal-to-Noise + Distortion of 80 dB for the ADCs
- Total Signal-to-Noise + Distortion of 78 dB for the DACs
- Programmable Gain Amplifier
- 600- Ω Driver
- 8- Ω AT41 Differential Speaker Driver With Programmable Gain Amplifier
- Flash Write Enable Circuit Provide Power for Writing the Flash Memory Device
- Available in 48-Pin PT (TQFP) Package Operating From -40°C to 85°C
- Transformer Reference (2.5 mA Source and Sink at 2.5 V for 5 V-Supply and 1.5 V for 3.3-V Supply) to allow Single-Ended Driving

1.2 Functional Block Diagram

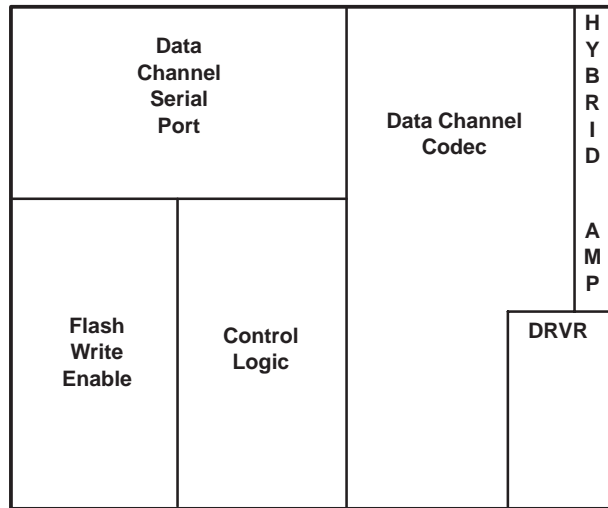

1.3 Analog Block Diagram

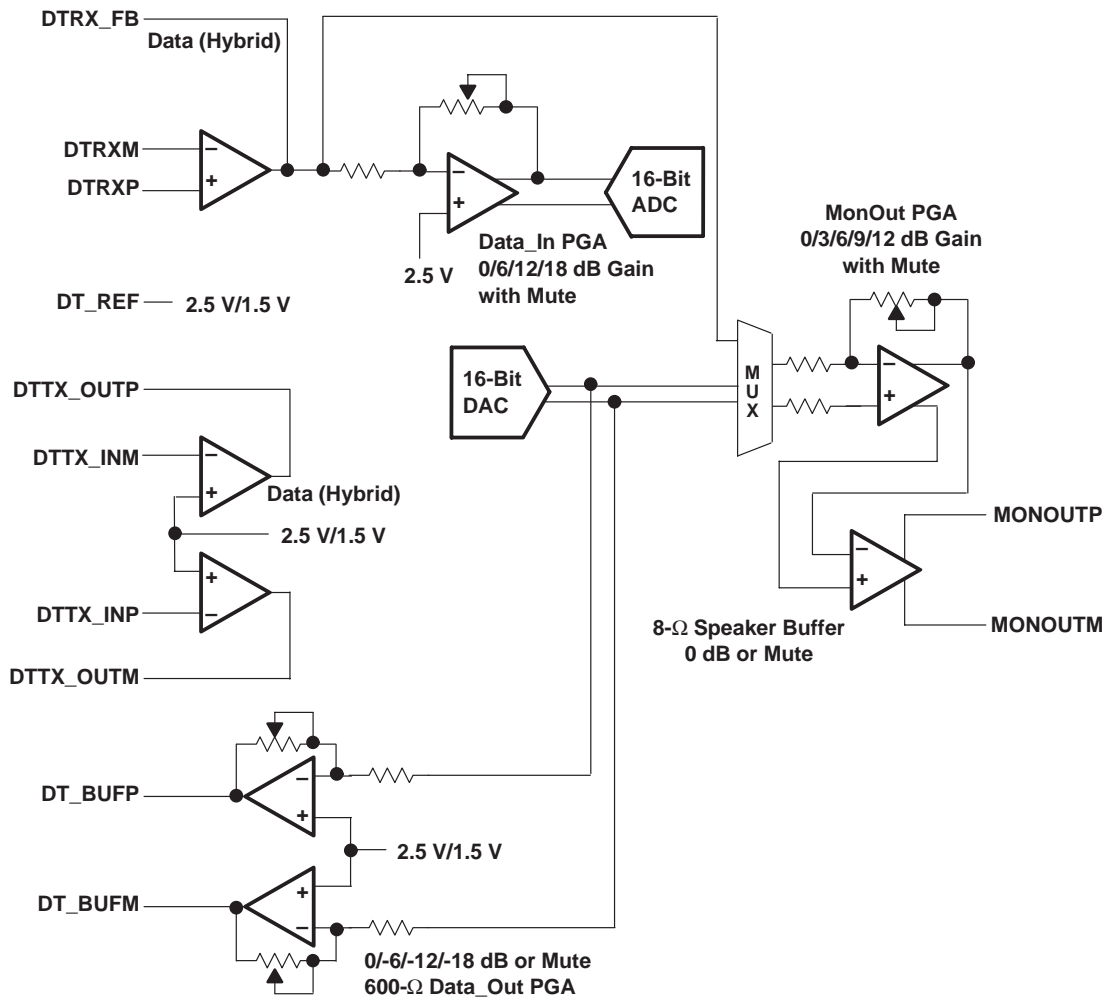

1.4 Terminal Assignments

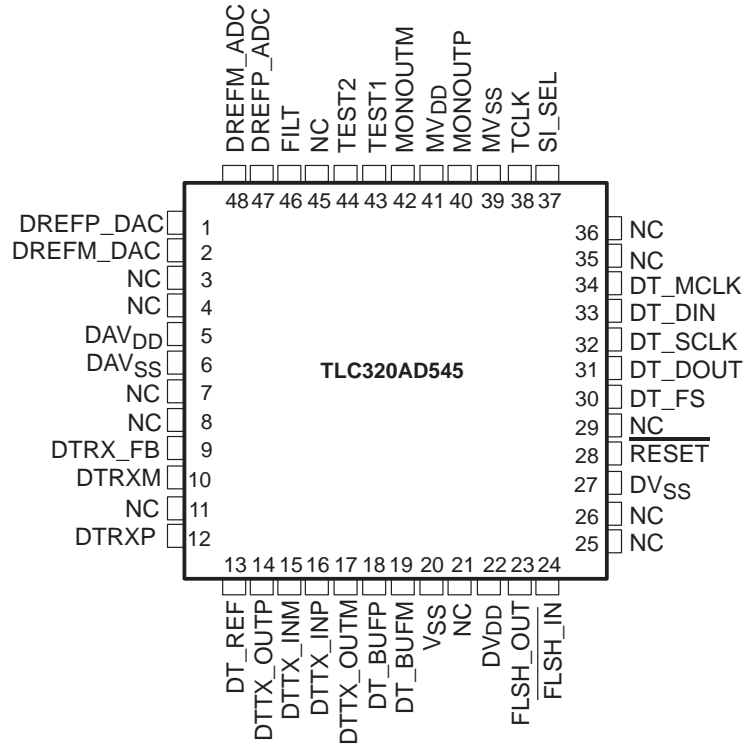

NC—Make no external connection

1.5 Ordering Information

T _A	PACKAGE
	PLASTIC QUAD FLATPACK (PT)
0°C to 70°C	TLC320AD545PT
-40°C to 85°C	TLC320AD545IPT

1.6 Terminal Functions

TERMINAL NAME	NO.	I/O	DESCRIPTION
NC	3, 4, 7, 8, 11, 21, 25, 26, 35, 36, 45		No connection
DAV _{DD}	5	I	Analog power supply (5 V/3.3 V)
DAV _{SS}	6	I	Analog ground
DREFM_ADC	48	O	ADC voltage reference filter output. DREFM_ADC provides lowpass filtering for the internal bandgap reference. The optimal ceramic capacitor value is 0.1 μF connected between DREFM_ADC and DREFP_ADC. The nominal dc voltage at this terminal is 0 V.
DREFM_DAC	2	O	DAC voltage reference filter output. DREFM_DAC provides for lowpass filtering the internal bandgap reference. The optimal ceramic capacitor value is 0.1 μF connected between DREFM_ADC and DREFP_ADC. The nominal dc voltage at this terminal is 0 V.

1.6 Terminal Functions (Continued)

TERMINAL NAME	NO.	I/O	DESCRIPTION
DREFP_ADC	47	O	ADC voltage reference filter output. DREFP_ADC provides lowpass filtering for the internal bandgap reference. The optimal ceramic capacitor value is 0.1 μ F connected between DREFM_ADC and DREFP_ADC. The dc voltage at this terminal is 3.375 V with a 5-V DAV _{DD} supply and 2.25 V with a 3.3-V DAV _{DD} supply.
DREFP_DAC	1	O	DAC voltage reference filter output. DREFP_DAC provides for lowpass filtering the internal bandgap reference. The optimal ceramic capacitor value is 0.1 μ F connected between DREFM_DAC and DREFP_DAC. The dc voltage at this terminal is 3.375 V at 5-V DAV _{DD} supply and 2.25 V at 3.3-V DAV _{DD} supply.
DT_BUFM	19	O	Buffer amp analog inverting output. DT_BUFM can be programmed for 0 dB, -6 dB, -12 dB, and -18 dB gain or muted using the control registers. This output is normally fed to the DTTX_INM terminal through an input resistor.
DT_BUFP	18	O	Buffer amp analog noninverting output. DT_BUFP can be programmed for 0 dB, -6 dB, -12 dB and -18 dB gain or muted using the control registers. This output is normally fed to the DTTX_INP terminal through an input resistor. DT_BUFP must be left unconnected in single-ended hybrid.
DT_DIN	33	I	Digital data input. DT_DIN handles DAC input data as well as control register programming information during frame sync interval and is synchronized to DT_SCLK.
DT_DOUT	31	O	Digital data output. ADC output bits transmit data during the frame sync period which is synchronized to DT_SCLK. DT_DOUT is at high impedance when DT_FS is not activated.
DT_FS	30	O	Serial port frame sync signal. DT_FS signals the beginning of transmit for ADC data and receiving of DAC data. This signal can be active high (FS high mode) or active low (FS low mode) depending on the voltage applied to SI_SEL (see Section 4, <i>Serial Communications</i>).
DT_MCLK	34	I	Master clock input. All internal clocks are derived from this clock.
DT_REF	13	O	Reference voltage for the transformer at 2.5 V for a 5-V DAV _{DD} supply and 1.5 V for a 3.3-V DAV _{DD} supply. The maximum source or sink current at this terminal is 2.5 mA. DT_REF must be left unconnected in differential hybrid.
DTRX_FB	9	O	Receive path amplifier feedback node. DTRX_FB terminal is connected to the noninverting output of the receive path amplifier and allows a parallel resistor/capacitor to be placed in the amplifier feedback path for setting gain and filter poles.
DTRXM	10	I	Receive path amplifier analog inverting input
DTRXP	12	I	Receive path amplifier analog noninverting input
DT_SCLK	32	O	Shift clock signal. DT_SCLK clocks serial data into DT_DIN and out of DT_DOUT during the frame-sync interval. DT_SCLK rate is DT_MCLK/2.
DTTX_INM	15	I	Transmit amplifier analog inverting input. This node is normally fed by the DT_BUFM output through an input resistor.
DTTX_INP	16	I	Transmit amplifier analog noninverting input. This node is normally fed by the DT_BUFP output through an input resistor. DTTX_INP must be shorted to DTTX_OUTM in single-ended hybrid.
DTTX_OUTM	17	O	Transmit amplifier analog inverting output. DTTX_OUTM must be shorted to DTTX_INP in single-ended hybrid.
DTTX_OUTP	14	O	Transmit amplifier analog noninverting output
DVDD	22	I	Digital and RESET circuit power supply (5 V/3.3 V)
DVSS	27	I	Digital and RESET circuit ground
FILT	46	O	Bandgap filter node. FILT provides decoupling of the bandgap reference voltage. This reference is 3.375 V with a 5-V supply and 2.25 V with a 3.3-V supply. The optimal capacitor value is 0.1 μ F (ceramic). This node should not be used as a voltage source.
FLSH_IN	24	I	External ASIC logic input. When brought low, FLSH_IN enables the FLSH_OUT output.
FLSH_OUT	23	O	Power output to write/erase flash EEPROM device (such as Intel™ 28F400B or AMD™ Am29F400). Supplies 45 mA maximum from 5 V when FLSH_IN is brought low.
MONOUTM	42	O	Analog output from 8- Ω monitor speaker amplifier which can be set for 0-dB gain or muted through the control registers.
MONOUTP	40	O	Analog output from 8- Ω monitor speaker amplifier which can be set for 0-dB gain or muted through the control registers.

Intel is a trademark of Intel Systems, Inc.

AMD is a trademark of Advanced Micro Devices, Inc.

1.6 Terminal Functions (Continued)

TERMINAL NAME	NO.	I/O	DESCRIPTION
MV _{DD}	41	I	Monitor amplifier supply (5 V/3.3 V)
MV _{SS}	39	I	Monitor amplifier ground
RESET	28	I	Codec device reset. $\overline{\text{RESET}}$ initializes all device internal registers to default values. This signal is active low.
SI_SEL	37	I	Serial interface mode select. When SI_SEL is tied to DV _{DD} , the serial port is in FS high mode. When SI_SEL is tied to DV _{SS} , the serial port is in FS low mode. (see Section 4, <i>Serial Communications</i>).
TCLK	38	O	Test output port. TCLK is for factory test only and should be either connected to ground or left unconnected.
TEST1	43	I/O	Test input port. TEST1 is for factory test only and should be either connected to ground or left unconnected.
TEST2	44	I/O	Test input port. TEST2 is for factory test only and should be either connected to ground or left unconnected.
V _{SS}	20	I	Internal substrate connection. V _{SS} should be tied to DAV _{SS} .

2 Functional Description

2.1 Device Requirements and System Overview

The TLC320AD545 device consists of single codec channel, a hybrid circuit with external resistors and capacitors for setting gain and filter poles, serial port, and miscellaneous other logic functions.

2.2 Codec Functions

The codec portion of the device performs the functions for:

- One channel of analog-to-digital conversion
- Digital-to-analog conversion
- Lowpass filtering
- Control of analog input and output gains
- Internal oversampling coupled with internal decimation and interpolation
- A 16-bit serial port interface to the host processor.

The maximum sample rate is 11.025 kHz.

2.3 Hybrid Functions

The hybrid circuitry has integrated amplifiers whose gains and filter pole frequencies are set by external resistors and capacitors. This allows maximum flexibility to make adjustments for board variations and international standards while providing integration of the function. The filter amplifier stages are followed by a programmable gain amplifier, which feeds an 8 Ω differential speaker driver for the AT41 call progress monitor speaker. The monitor speaker driver can be programmed for 0 dB gain or muted through control register 2. The source for the monitor speaker input can be chosen to be either the amplified DAC output (Data_Out PGA) or the ADC input signal through control register 1 (see *Appendix A*).

A 2.5 V/1.5 V reference voltage (DT_REF) is provided as a reference for the transformer. It is necessary to reference to 2.5 V/1.5 V (rather than ground), since the amplifiers are powered off by single-rail supplies. DT_REF is 2.5 V when DAV_{DD} is 5 V and 1.5 V when DAV_{DD} is 3.3 V.

2.4 Miscellaneous Logic and Other Circuitry

The logic functions include the circuitry required to implement serial port and control register programming through secondary communication on those serial ports. Two control registers can be programmed during secondary communications from the serial port. These control registers set amplifier gains, select loopback functions, and read ADC overflow flags. In addition, a flash write enable (FWE) circuit takes an external logic input and provides current to power the write enable circuit of an external memory device. The flash write enable circuit is powered from the digital power supply.

3 Codec Functional Description

3.1 Operating Frequencies

The TLC320AD545 is capable of supporting any sample rate up to the maximum sample rate of 11.025 kHz. The sample rate is set by the frequency of the codec master clock.

The sampling (conversion) frequency is derived from the codec master clock by the internal clock divider circuit by equation (1):

$$DT_FS = \text{Sampling (conversion) frequency} = DT_MCLK/512 \quad (1)$$

The shift clock (SCLK) is derived from the codec master clock divider circuit by equation (2):

$$DT_SCLK \text{ (frequency)} = DT_MCLK/2 \quad (2)$$

Where MCLK is codec clock fed to the codec externally by the clock rate divider circuit which divides the system master clock to get the necessary clock frequency to feed the codec.

The conversion period is the inverse of sampling frequency.

3.2 ADC Signal Channel

The input signals are amplified and filtered by on-chip buffers before being applied to ADC input. The ADC converts the signal into discrete output digital words in 2s-complement format, corresponding to the analog signal value at the sampling time. These 16-bit digital words, representing sampled values of the analog input signal, are sent to the host through the serial port interface. If the ADC reaches its maximum value, a control register flag is set. This overflow bit resides at D0 in control register 2. This bit can only be read from the serial port, and the overflow flag is only cleared if it is read through the serial port. The ADC and DAC conversions are synchronous and phase-locked.

3.3 DAC Signal Channel

The DAC receives 16-bit data words (2s complement) from the host through the serial port interface. The data is converted to an analog voltage by the sigma-delta DAC comprised of a digital interpolation filter and a digital modulator. The DAC output is then passed to an internal low-pass filter to complete the signal reconstruction resulting in an analog signal. This analog signal is then buffered and amplified by differential output driver capable of driving the required load. The gain of the DAC output amplifier is programmed by the codec control register as shown in Appendix A.

3.4 Sigma-Delta ADC

The ADC is an oversampling sigma-delta modulator. The ADC provides high resolution and low noise performance using oversampling techniques and the noise shaping advantages of sigma-delta modulators.

3.5 Decimation Filter

The decimation filter reduces the digital data rate to the sampling rate. This is accomplished by decimating with a ratio equal to the oversampling ratio. The output of this filter is a sixteen-bit 2s-complement data word clocking at the selected sample rate.

3.6 Sigma-Delta DAC

The DAC is an oversampling sigma-delta modulator. The DAC perform high-resolution, low-noise digital-to-analog conversion using oversampling sigma-delta techniques.

3.7 Interpolation Filter

The interpolation filter resamples the digital data at a rate of N times the incoming sample rate where N is the oversampling ratio. The high-speed data output from this filter is then applied to the sigma-delta DAC.

3.8 Analog and Digital Loopbacks

The test capabilities include an analog loopback and digital loopback. The loopbacks provide a means of testing the ADC/DAC channels and can be used for in-circuit system-level tests.

Analog loopback loops the DAC output back into the ADC input. Digital loopback loops the ADC output back into the DAC input. Analog loopback is enabled by setting bit D4 in the control register 1. Digital loopback is enabled by setting bit D5 high in control register 1. The analog loopback function tests only the codec portion of the device and does not include the hybrid amplifier.

3.9 Software Power Down

The software power down resets all internal counters but leaves the contents of the programmable control registers unchanged. The software power down feature is invoked by setting bit D6 high in control register 1. There is no hardware power down function in the TLC320AD545.

3.10 Test Module

The test module serves the purpose of facilitating design verification test and simplifying factory production testing. There are three input/output terminals (TEST1, TEST2 and TCLK) dedicated to implementing the test functions. The function of these terminals is for factory self-test only and no connection (NC) should be made to either of these terminals.

3.11 Power Supply Options

	ANALOG SUPPLY (DAV _{DD})	DIGITAL SUPPLY (DV _{DD})	MONITOR SUPPLY (MV _{DD})
Option 1	5 V	5 V	5 V
Option 2	3.3 V	3.3 V	3.3 V
Option 3	5 V	3.3 V	5 V

4 Serial Communications

DT_DOUT, DT_DIN, DT_SCLK, and DT_FS, are the serial communication signals for the serial port. The digital output data from the ADC is taken from DT_DOUT. The digital input data for the DAC is applied to DT_DIN. The synchronization clock for the serial communication data and the frame-sync is taken from DT_SCLK. The frame-sync pulse, which signals the beginning of the ADC and DAC data transfer interval, is taken from DT_FS.

For signal data transmitted from the ADC or to the DAC, a primary serial communication is used. A secondary communication is used to read or write words to the control registers, which control both the options and the circuit configurations of the device.

The purpose of the primary and secondary communications is to allow conversion data and control data to be transferred across the same serial port. A primary transfer is always dedicated to conversion data. A secondary transfer is used to set up or read the control register values described in *Appendix A, Programmable Register Set*. A primary transfer occurs for every conversion period. A secondary transfer occurs only when requested. Secondary serial communication is requested by software (D0 of the primary data input to DT_DIN). Control registers 1 and 2 can only be read/write from/to the serial port.

4.1 Primary Serial Communication

Primary serial communication is used to both transmit and receive conversion signal data. The DAC word length is 15 bits and the last bit of the primary 16-bit serial communication word is a control bit used to request secondary serial communication. For all serial communications, the most significant bit is transferred first. For the 16-bit ADC word, D15 is the most significant bit and D0 is the least significant bit. For the 15-bit DAC data word in a primary communication, D15 is the most significant bit, D1 is the least significant bit, and D0 is used for the secondary communication request control. All digital data values are in 2s-complement data format. Refer to Figure 4–1.

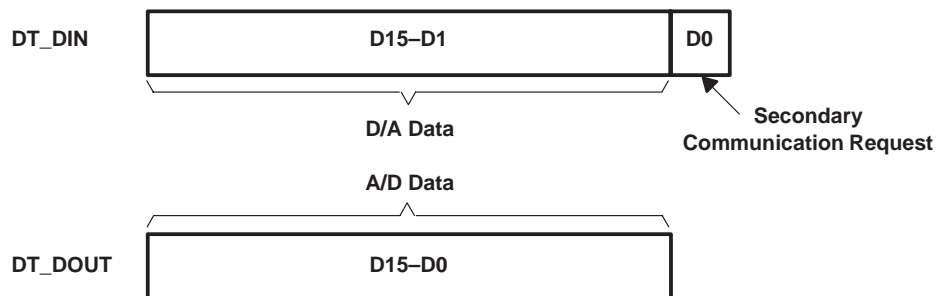

Figure 4–1. Primary Communication DIN and DOUT Data Format

4.1.1 FS High Mode Primary Communication Timing

There are two possible modes for serial data transfer. One mode is the FS high mode, which is selected by tying the SI_SEL terminal to DV_{DD}. Figure 4–2 shows the timing relationship for DT_SCLK, DT_FS, DT_DOUT and DT_DIN in a primary communication when in FS high mode. The timing sequence for this operation is as follows:

1. DT_FS is brought high and remains high for one DT_SCLK period, then goes back low.
2. A 16-bit word is transmitted from the ADC (DT_DOUT) and a 16-bit word is received for DAC conversion (DT_DIN).

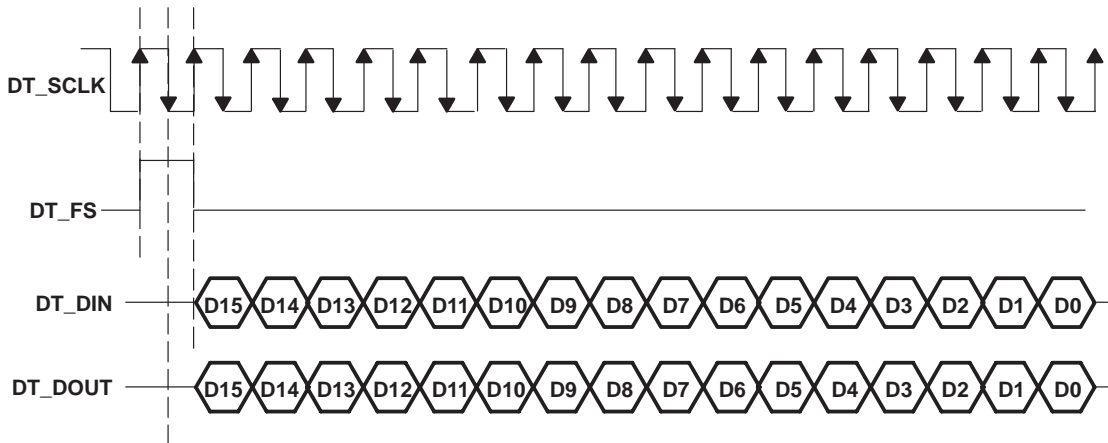

Figure 4–2. FS High Mode Primary Serial Communication Timing

4.1.2 FS Low Mode Primary Communication Timing

The second possible serial interface mode is the FS low mode which is selected by tying the SI_SEL terminal to DV_{SS}. This mode differs from the FS high mode in that the frame sync signal (FS) is active low, data transfer starts on the falling edge of DT_FS, and DT_FS remains low throughout the data transfer. Figure 4–3 shows the timing relationship for DT_SCLK, DT_FS, DT_DOUT, and DT_DIN in a primary communication when in FS low mode. The timing sequence for this operation is as follows:

1. DT_FS is brought low by the TLC320AD545.
2. A 16-bit word is transmitted from the ADC (DT_DOUT) and a 16-bit word is received for DAC conversion (DT_DIN).
3. DT_FS is brought high signaling the end of the data transfer.

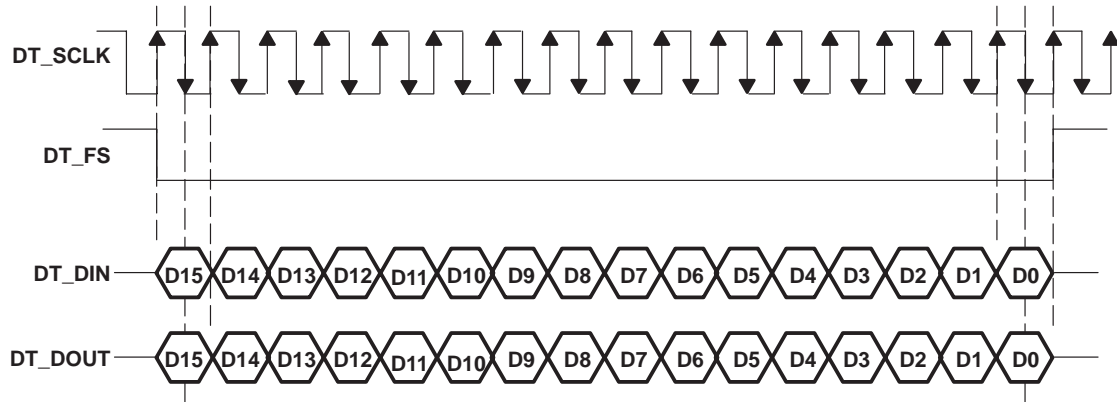

Figure 4–3. FS Low Mode Primary Serial Communication Timing

4.2 Secondary Serial Communication

Secondary serial communication is used to read or write 16-bit words that program both the options and the circuit configurations of the device. Register programming always occurs during secondary communication. Control registers 1 and 2 can only be written to or read from the serial port. Two primary and secondary communication cycles are necessary to program the control registers. If the default value for a particular register is desired, then the register addressing can be omitted during secondary communications. The NOOP (no operation) command addresses a pseudo-register, register 0, and no register programming takes place during this secondary communication.

During a secondary communication, a register may be written to or read from. When writing a value to a register, the DT_DIN line contains the value to be written. The data returned on DT_DOUT is 00h.

The method for requesting a secondary communication is by asserting the least significant bit (D0) of DT_DIN high as shown in Table 4–1.

Table 4–1. Least-Significant-Bit Control Function

CONTROL BIT D0	CONTROL BIT FUNCTION
0	No secondary communication request
1	Secondary communication request

Figure 4–4 shows the data format XX_DIN and XX_DOUT during secondary communication.

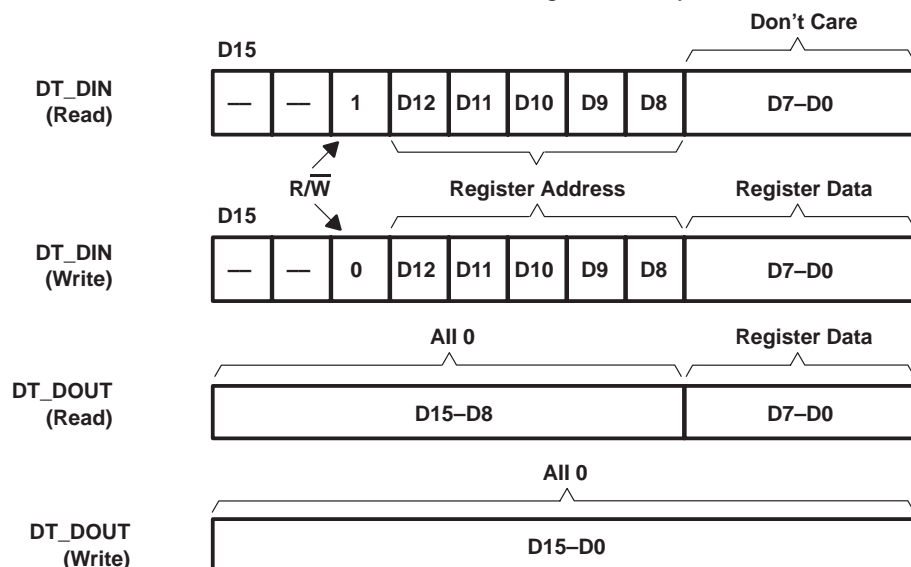

Figure 4–4. Secondary Communication DIN and DOUT Data Format

4.3 FS High Mode Secondary Communication Timing

On the rising edge of DT_SCLK, coinciding with the falling edge of FS, D15–D0 is input serially to DT_DIN and D15–D0 is output serially on DT_DOUT. If a secondary communication request is made, FS goes high again, 128 SCLKs after the beginning of the primary frame, to signal the beginning of the secondary frame one SCLK period later. See Figure 4–5.

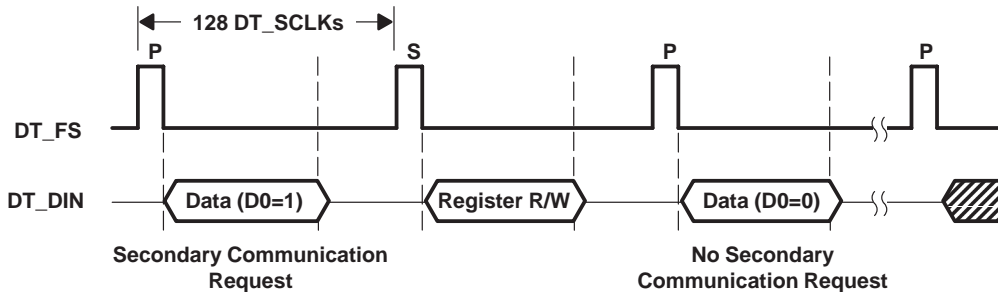

Figure 4–5. FS Output During Software Secondary Serial Communication Request (FS High Mode)

4.4 FS Low Mode Secondary Communication Timing

On the falling edge of FS for that channel, D15–D0 is input serially to DT_DIN and D15–D0 is output serially on DT_DOUT. FS remains low during the data transfer and then returns high. If a secondary communication request is made, FS goes low 128 SCLKs after the beginning of the primary frame to signal the beginning of the secondary frame. See Figure 4–6.

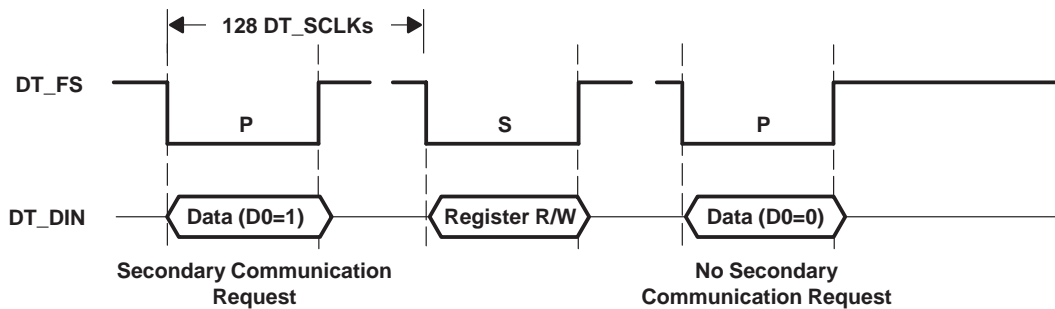

Figure 4–6. FS Output During Software Secondary Serial Communication Request (FS Low Mode)

5 Specifications

5.1 Absolute Maximum Ratings Over Operating Free-Air Temperature Range (Unless Otherwise Noted)

Supply voltage range, DV_{DD} , AV_{DD} , (see Note 1)	-0.3 V to 7 V
Output voltage range, all digital output signals	-0.3 V to $DV_{DD}+0.3$ V
Input voltage range, all digital input signals	-0.3 V to $DV_{DD}+0.3$ V
Case temperature for 10 seconds: PM package	260°C
Operating free-air temperature range, T_A	-40°C to 85°C
Storage temperature range, T_{stg}	-65°C to 150°C

† Stresses beyond those listed under “absolute maximum ratings” may cause permanent damage to the device. These are stress ratings only and functional operation of the device at these or any other conditions beyond those indicated under “recommended operating conditions” is not implied. Exposure to absolute-maximum-rated conditions for extended periods may affect device reliability.

NOTE 1: All voltage values are with respect to V_{SS} .

5.2 Recommended Operating Conditions

	MIN	NOM	MAX	UNIT
Supply voltage, DAV_{DD} , MV_{DD} , DV_{DD} (5-V supply)	4.5	5	5.5	V
Supply voltage, DAV_{DD} , MV_{DD} , DV_{DD} (3.3-V supply) (see Note 2)	3	3.3	3.6	V
Analog signal peak-to-peak input voltage [‡] , $DTRXM$, $DTRXP$, $V_{I(ANALOG)}$ (5-V supply)			3	V
Analog signal peak-to-peak input voltage [‡] , $DTRXM$, $DTRXP$, $V_{I(ANALOG)}$ (3.3-V supply)			2	V
Differential output load resistance, R_L (DT_BUFP , DT_BUFM)	600			Ω
Differential output load resistance, R_L ($MONOUTP$, $MONOUTM$)	8			Ω
Input impedance for hybrid amps ($DTRXP$, $DTRXM$, $DTTX_INP$, $DTTX_INM$)		50		kΩ
Master clock			5.645	MHz
Load capacitance, C_L			20	pF
ADC or DAC conversion rate		8	11.025	kHz
Operating free-air temperature, T_A	0		70	°C

[‡] Preamplifier gain set to 0 dB

NOTE 2: Voltages at analog inputs and outputs and xV_{DD} are respect to the xV_{SS} terminal.

5.3 Electrical Characteristics Over Recommended Operating Free-Air Temperature Range $DV_{DD} = 5\text{ V}/3.3\text{ V}$, $AV_{DD} = 5\text{ V}/3.3\text{ V}$, $MV_{DD} = 5\text{ V}/3.3\text{ V}$

5.3.1 Digital Inputs and Outputs, $f_s = 8\text{ kHz}$, Outputs Not Loaded

PARAMETER	TEST CONDITIONS	MIN	TYP	MAX	UNIT
V_{OH} High-level output voltage, any digital output	$I_O = -360\ \mu\text{A}$	2.4		$DV_{DD} + 0.5$	V
V_{OL} Low-level output voltage, any digital output	$I_O = 2\text{ mA}$			$DV_{SS} - 0.5$ 0.4	V
I_{IH} High-level input current, any digital input	$V_{IH} = 5\text{ V}$			10	μA
I_{IL} Low-level input current, any digital input	$V_{IL} = 0.6\text{ V}$			10	μA
C_j Input capacitance, any digital input			10		pF
C_O Output capacitance, any digital output			10		pF
$I_{I(kg)}$ Input leakage current, any digital input				10	μA
I_{OZ} Output leakage current, any digital output				10	μA

5.3.2 ADC Channel, $f_s = 8\text{ kHz}$ (see Note 3)

PARAMETER	TEST CONDITIONS	MIN	TYP	MAX	UNIT
Filter gain relative to gain at 1020 Hz	0 to 300 Hz	-0.5		0.2	dB
	300 Hz to 3 kHz	-0.25		0.25	
	3.3 kHz	-0.35		0.3	
	3.6 kHz			-3	
	4 kHz			-35	
	$\geq 4.4\text{ kHz}$			-74	

NOTE 3: The filter gain outside of the passband is measured with respect to the gain at 1020 Hz. The analog input test signal is a sine wave with 0 dB=3 V_{PP} at 5-V supply and 0 dB = 2 V_{PP} at 3.3-V supply differential as the reference level for ADC analog input signal. The -3 dB passband is 0 to 3600 Hz for an 8-kHz sample rate. This passband scales linearly with the sample rate.

5.3.3 ADC Dynamic Performance, $f_s = 8\text{ kHz}$

5.3.3.1 ADC Signal-to-Noise (see Note 4)

PARAMETER	TEST CONDITIONS	MIN	TYP	MAX	UNIT
Signal-to-noise ratio (SNR)	$V_I = -1\text{ dB}$	76	81		dB
	$V_I = -9\text{ dB}$	68	73		
	$V_I = -40\text{ dB}$	37	42		

NOTE 4: The test condition is a 1020-Hz input signal with an 8-kHz conversion rate. Input and output common mode is 2.5 V for 5 V supply and 1.5 V for 3.3 V supply. The output configuration is in a 5 V differential-ended mode.

5.3.3.2 ADC Signal-to-Distortion (see Note 4)

PARAMETER	TEST CONDITIONS	MIN	TYP	MAX	UNIT
Signal-to-total harmonic distortion (THD)	$V_I = -3\text{ dB}$	74	79		dB
	$V_I = -9\text{ dB}$	82	87		
	$V_I = -40\text{ dB}$	58	63		

NOTE 4: The test condition is a 1020-Hz input signal with an 8-kHz conversion rate. Input and output common mode is 2.5 V for 5 V supply and 1.5 V for 3.3 V supply. The output configuration is in a 5 V differential-ended mode.

5.3.3.3 ADC Signal-to-Distortion + Noise (see Note 4)

PARAMETER	TEST CONDITIONS	MIN	TYP	MAX	UNIT
Signal-to-total harmonic distortion + noise (THD + N)	$V_I = -3$ dB	71	76		dB
	$V_I = -9$ dB	68	73		
	$V_I = -40$ dB	37	42		

NOTE 4: The test condition is a 1020-Hz input signal with an 8-kHz conversion rate. Input and output common mode is 2.5 V for 5-V supply and 1.5 V for 3.3-V supply. The output configuration is in a 5 V differential-ended mode.

5.3.4 ADC Characteristics

PARAMETER	TEST CONDITIONS	MIN	TYP	MAX	UNIT
$V_{I(PP)}$ Peak-input voltage (5.0 V supply)	Preamp gain = 0 dB			3	V
$V_{I(PP)}$ Peak-input voltage (3.3 V supply)	Preamp gain = 0 dB			2	V
Dynamic range	$V_I = -1$ dB at 1020 Hz		80		dB
Interchannel isolation			87		dB
E_G Gain error	$V_I = -1$ dB at 1020 Hz		± 0.5		dB
$E_{O(ADC)}$ ADC channel offset error including hybrid amplifiers			3	12	mV
CMRR Common-mode rejection ratio	$V_I = -1$ dB at 1020 Hz		80		dB
Idle channel noise (on-chip reference)			50	100	μV_{rms}
Channel delay			$17/f_s$		s

5.3.5 DAC Channel, $f_s = 8$ kHz (see Note 5)

PARAMETER	TEST CONDITIONS	MIN	TYP	MAX	UNIT
Filter gain relative to gain at 1020 Hz	0 to 300 Hz	-0.5		0.2	dB
	300 Hz to 3 kHz	-0.25		0.25	
	3.3 kHz	-0.35		0.3	
	3.6 kHz			-3	
	4 kHz			-35	

NOTE 5: The filter gain outside of the passband is measured with respect to the gain at 1020 Hz. The input signal is the digital equivalent of a sine wave (digital full scale = 0 dB). The -3 dB pass band is 0 to 3600 Hz for an 8-kHz sample rate. This pass band scales linearly with the sample rate.

5.3.6 DAC Dynamic Performance

5.3.6.1 DAC Signal-to-Noise (see Note 6)

PARAMETER	TEST CONDITIONS	MIN	TYP	MAX	UNIT
Signal-to-noise ratio (SNR)	$V_I = 0$ dB	72	77		dB
	$V_I = -9$ dB	63	68		
	$V_I = -40$ dB	32	37		

NOTE 6: The test condition is a 1020-Hz input signal with an 8-kHz conversion rate. The output configuration is in a 5 V differential-ended mode.

5.3.6.2 DAC Signal-to-Distortion (see Note 6)

PARAMETER	TEST CONDITIONS	MIN	TYP	MAX	UNIT
Signal-to-total harmonic distortion (THD)	$V_I = -3$ dB	77	82		dB
	$V_I = -9$ dB	72	77		
	$V_I = -40$ dB	61	66		

NOTE 6: The test condition is a 1020-Hz input signal with an 8-kHz conversion rate. The output configuration is in a 5 V differential-ended mode.

5.3.6.3 DAC Signal-to-Distortion + Noise (see Note 6)

PARAMETER	TEST CONDITIONS	MIN	TYP	MAX	UNIT
Signal-to-total harmonic distortion + noise (THD + N)	$V_I = -3$ dB	73	78		dB
	$V_I = -9$ dB	67	72		
	$V_I = -40$ dB	32	37		

NOTE 6: The test condition is a 1020-Hz input signal with an 8-kHz conversion rate. The output configuration is in a 5 V differential-ended mode.

5.3.7 DAC Characteristics

PARAMETER	TEST CONDITIONS	MIN	TYP	MAX	UNIT
Dynamic range	$V_I = 0$ dB at 1020 Hz		82		dB
Interchannel isolation			100		dB
E_G Gain error	$V_I = 0$ dB at 1020 Hz		± 0.5		dB
Idle channel narrow-band noise	0 kHz to 4 kHz (see Note 7)		75	125	μ V rms
Channel delay			$18/f_S$		s
V_O Analog output voltage, MONOUTP-MONOUTM (5.0 V)	Differential with respect to common mode and full-scale digital input (see Note 8)	-1.78		1.78	V
V_O Analog output voltage, MONOUTP-MONOUTM (3.3 V)	Differential with respect to common mode and full-scale digital input (see Note 8)	-1.2		1.2	V
V_O Analog output voltage (5 V)	Differential with respect to common mode and full-scale digital input	-3		3	V
V_O Analog output voltage, (3.3 V)	Differential with respect to common mode and full-scale digital input	-2		2	V

NOTES: 7. The conversion rate is 8 kHz.

8. This amplifier should only be used in differential mode. Common mode : 2.5 V in 5-V supply, 1.5 V in 3.3-V supply.

5.3.8 Logic DC Electrical Characteristics

PARAMETER	MIN	TYP	MAX	UNIT
V_{IL} Low-level input voltage	-0.3		0.8	V
V_{IH} High-level input voltage	2		$DV_{DD}+0.3$	V
I_I (I _{kg}) Input leakage current			10	μ A
I_O (I _{kg}) Output leakage current			10	μ A
V_{OH} High-level output voltage at rated load current	2.4		$DV_{DD}+0.5$	V
V_{OL} Low-level output voltage at rated load current	$DV_{SS}-0.5$		0.4	V

5.3.9 Power-Supply Rejection (see Note 9)

PARAMETER	TEST CONDITIONS	MIN	TYP	MAX	UNIT
V_{DD1} Supply-voltage rejection ratio, ADC channel, DAV_{DD}	$f_I = 0$ to $f_S/2$		73		dB
V_{DD2} Supply-voltage rejection ratio, DAC channel, DAV_{DD}	$f_I = 0$ to $f_S/2$		76		
V_{DD3} Supply-voltage rejection ratio, ADC channel, DV_{DD}	$f_I = 0$ to $f_S/2$		86		
V_{DD4} Supply-voltage rejection ratio, DAC channel, DV_{DD}	$f_I = 0$ to 30 kHz		95		

NOTE 9: Power supply rejection measurements are made with both the ADC and the DAC channels idle and a 200 mV peak-to-peak signal applied to the appropriate supply.

5.3.10 Power-Supply

PARAMETER		TEST CONDITIONS	MIN	TYP	MAX	UNIT
I _{DD} (analog)	Codec power supply current, analog (including hybrid and drivers)	DAV _{DD} = 5 V	Operating		25	mA
		DAV _{DD} = 3.3 V	Operating		20	
I _{DD} (digital)	Codec power supply current, digital	DAV _{DD} = 5 V	Operating		5	mA
		DAV _{DD} = 3.3 V	Operating		4	
I _{DD} (monitor)	Power supply current, 8 Ω monitor speaker driver (5 V)	Operating	135	315		mA
I _{DD} (monitor)	Power supply current, 8 Ω monitor speaker driver (3.3 V)	Operating		240		mA

5.3.11 Flash Write Enable Circuit

PARAMETER		TEST CONDITIONS	MIN	TYP	MAX	UNIT
V _{OH} (FLSH_OUT)	Output high-level voltage (5 V supply), FLSH_OUT	FLSH_IN low	4.5	5	5.5	V
V _{OH} (FLSH_OUT)	Output high-level voltage (3.3 V supply), FLSH_OUT	FLSH_IN low	2.8	3.3	3.8	V
V _{OL} (FLSH_OUT)	Output low-level voltage, FLSH_OUT	FLSH_IN high	0		1.5	V
I _O (FLSH_OUT)	Output current (5 V supply), FLSH_OUT	FLSH_IN low		40	45	mA
I _O (FLSH_OUT)	Output current (3.3 V supply), FLSH_OUT	FLSH_IN low		25		mA

5.4 Timing Characteristics (see Parameter Measurement Information)

5.4.1 Timing Requirements

PARAMETER		MIN	TYP	MAX	UNIT
t _{d1}	Delay time, DT_SCLK↑ to DT_FS↓			0	ns
t _{su1}	Setup time, DT_DIN, before DT_SCLK low	25			ns
t _{h1}	Hold time, DT_DIN, after DT_SCLK high			20	ns
t _{d3}	Delay time, DT_MCLK↓ to DT_SCLK↑			50	ns
t _{wH}	Pulse duration, DT_MCLK high	32			ns
t _{wL}	Pulse duration, DT_MCLK low	20			ns

5.4.2 Switching Characteristics

PARAMETER		TEST CONDITIONS	MIN	TYP	MAX	UNIT
t _{d2}	Delay time, DT_SCLK↑ to DT_DOUT	C _L = 20 pF			20	ns
t _{en1}	Enable time, FS↓ to DT_DOUT				25	
t _{dis1}	Disable time, FS↑ to DT_DOUT Hi-Z			20		
T _{PW}	Reset pulse width		10MCLK			ns

5.5 Parameter Measurement Information

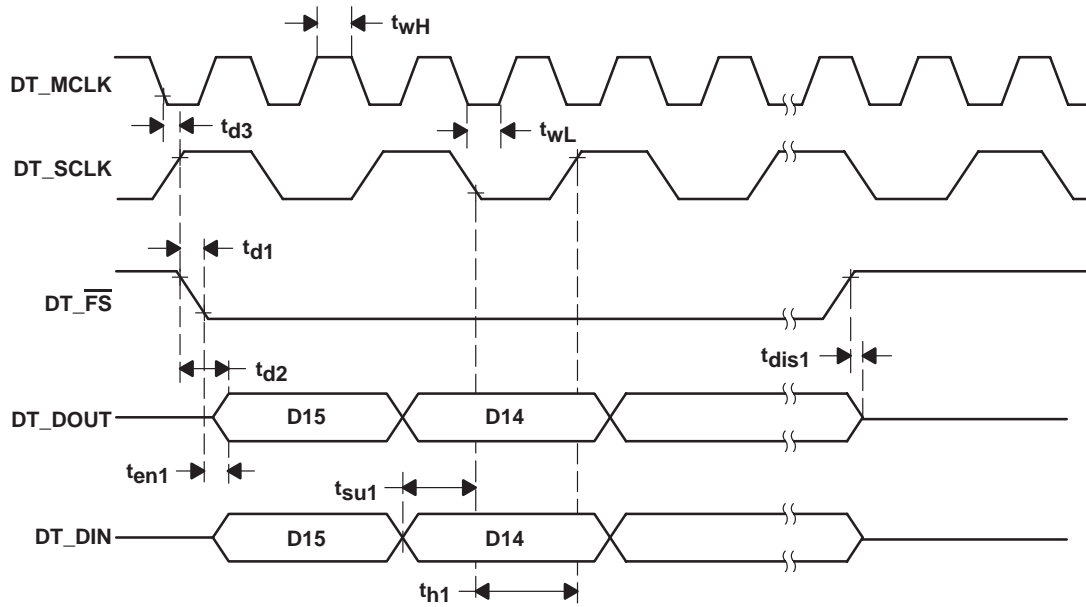

Figure 5–1. Serial Communication Timing

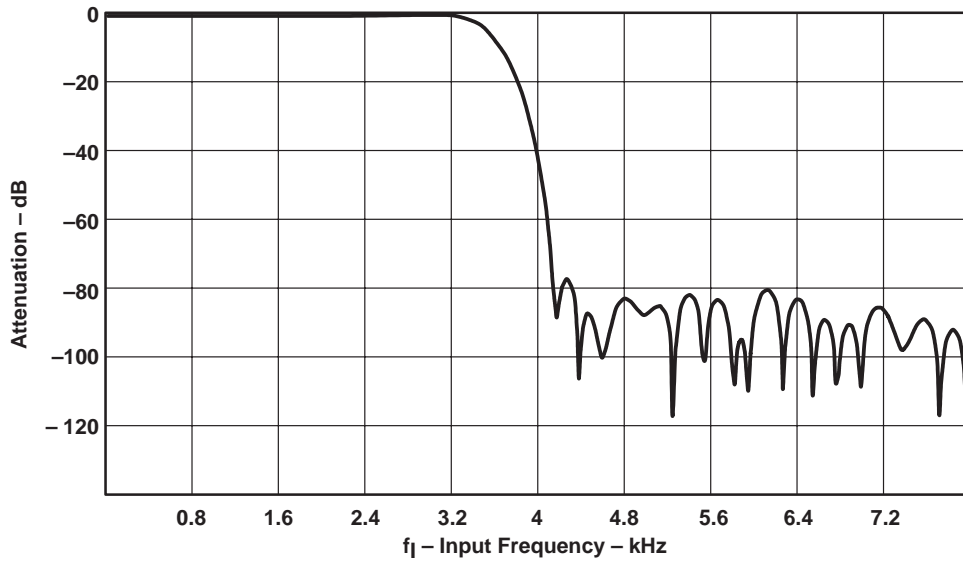

Figure 5–2. ADC Decimation Filter Response

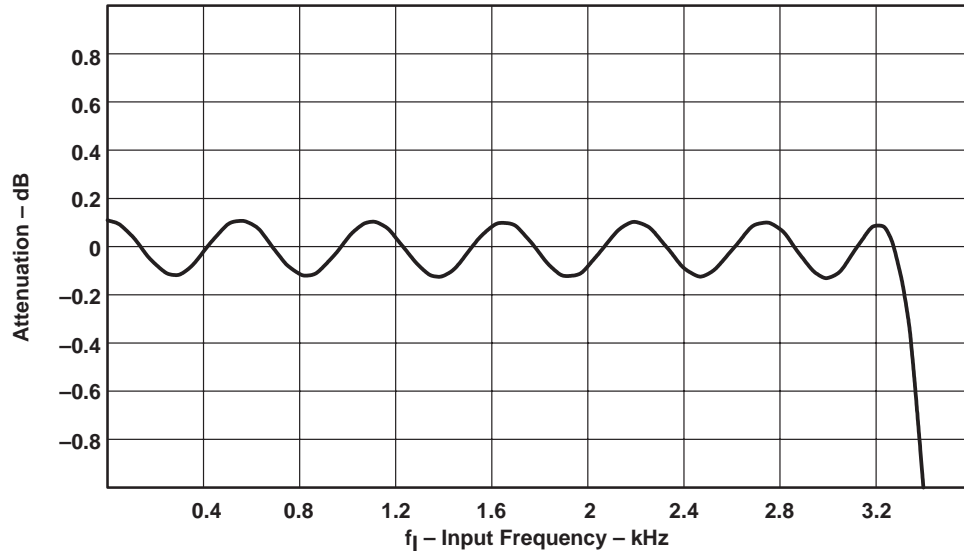

Figure 5-3. ADC Decimation Filter Passband Ripple

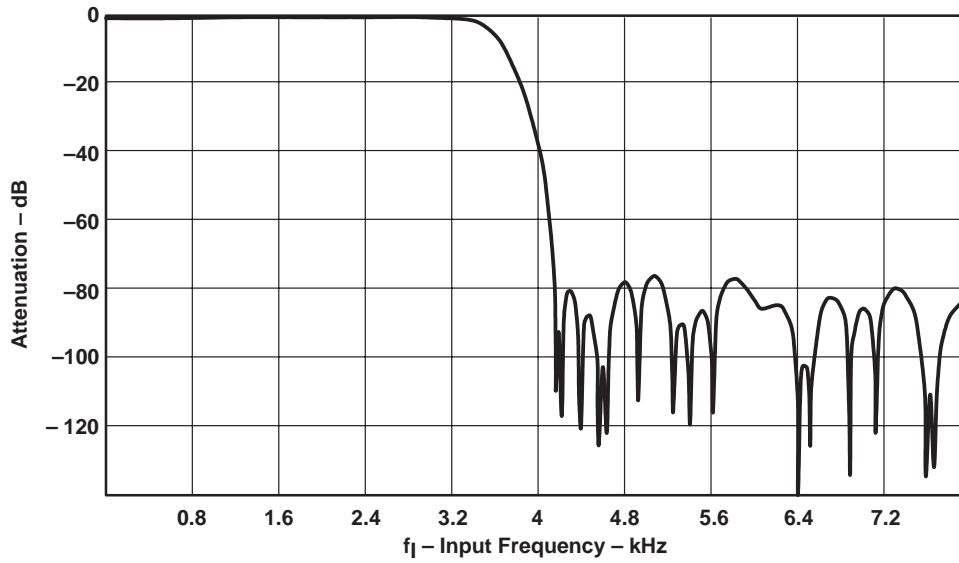

Figure 5-4. DAC Interpolation Filter Response

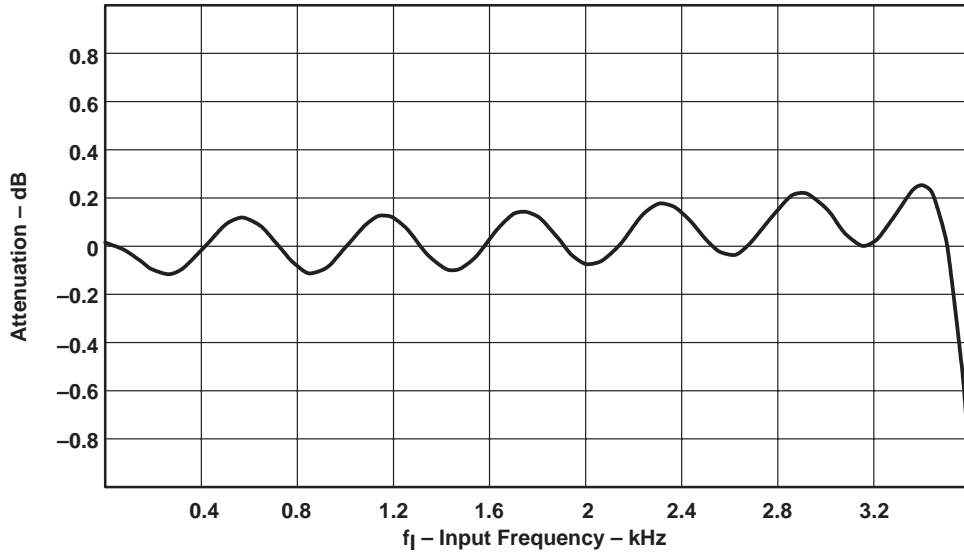

Figure 5-5. DAC Interpolation Filter Passband Ripple

6 Application Information

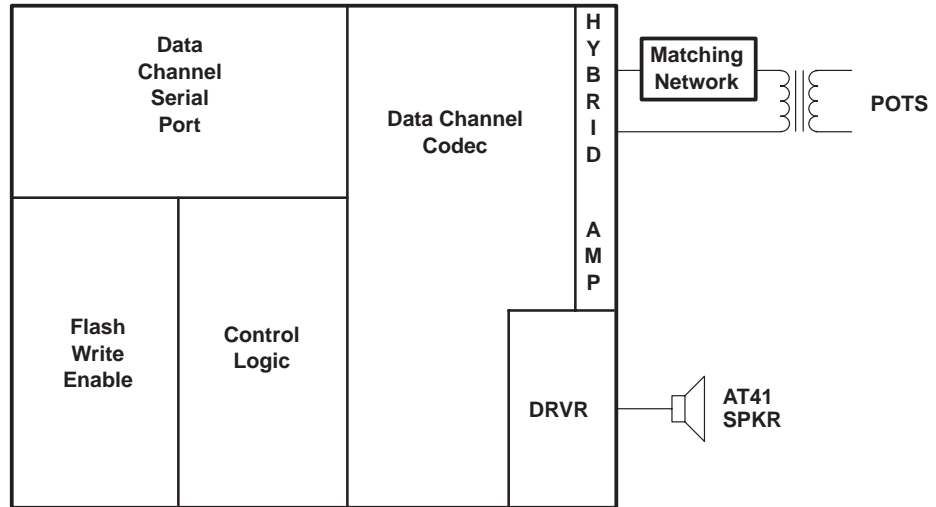
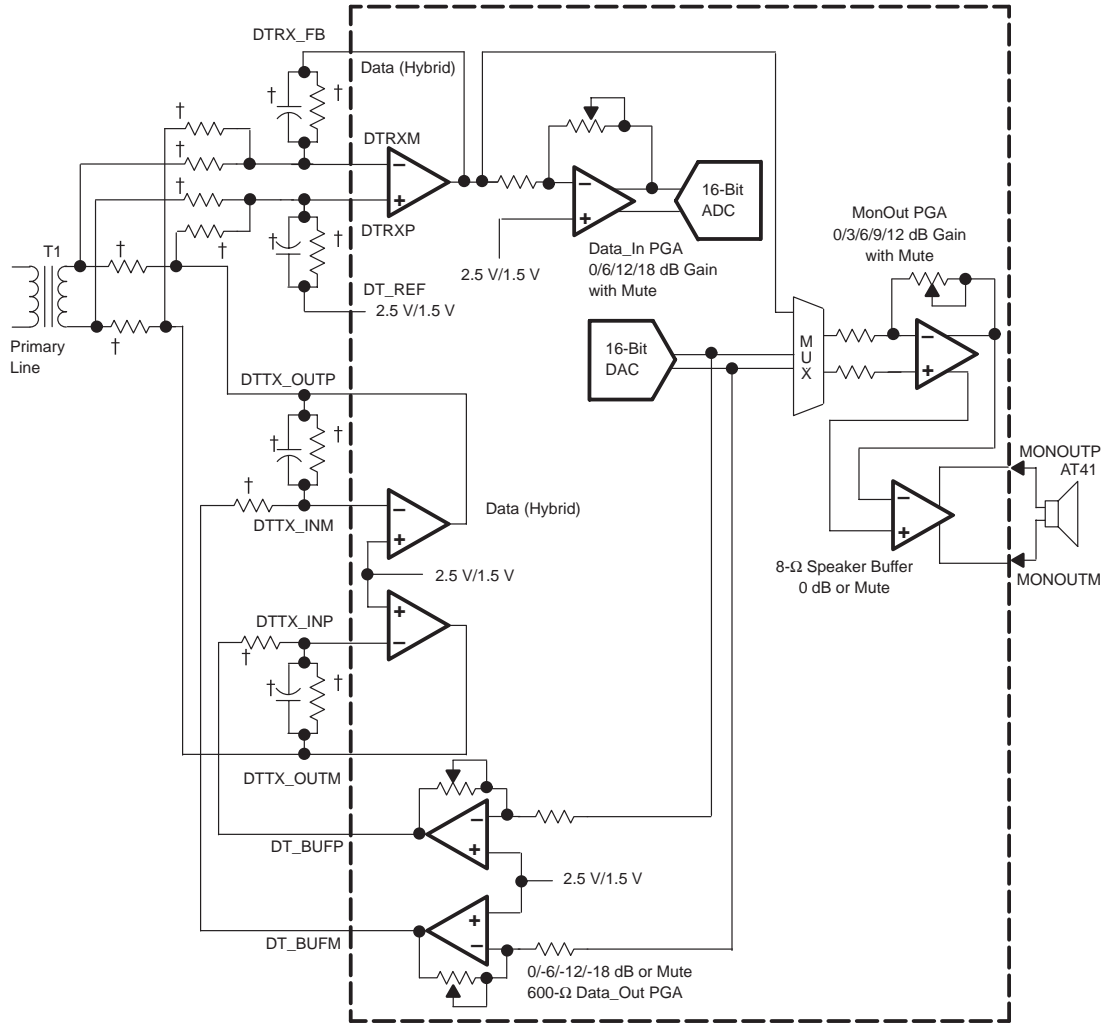
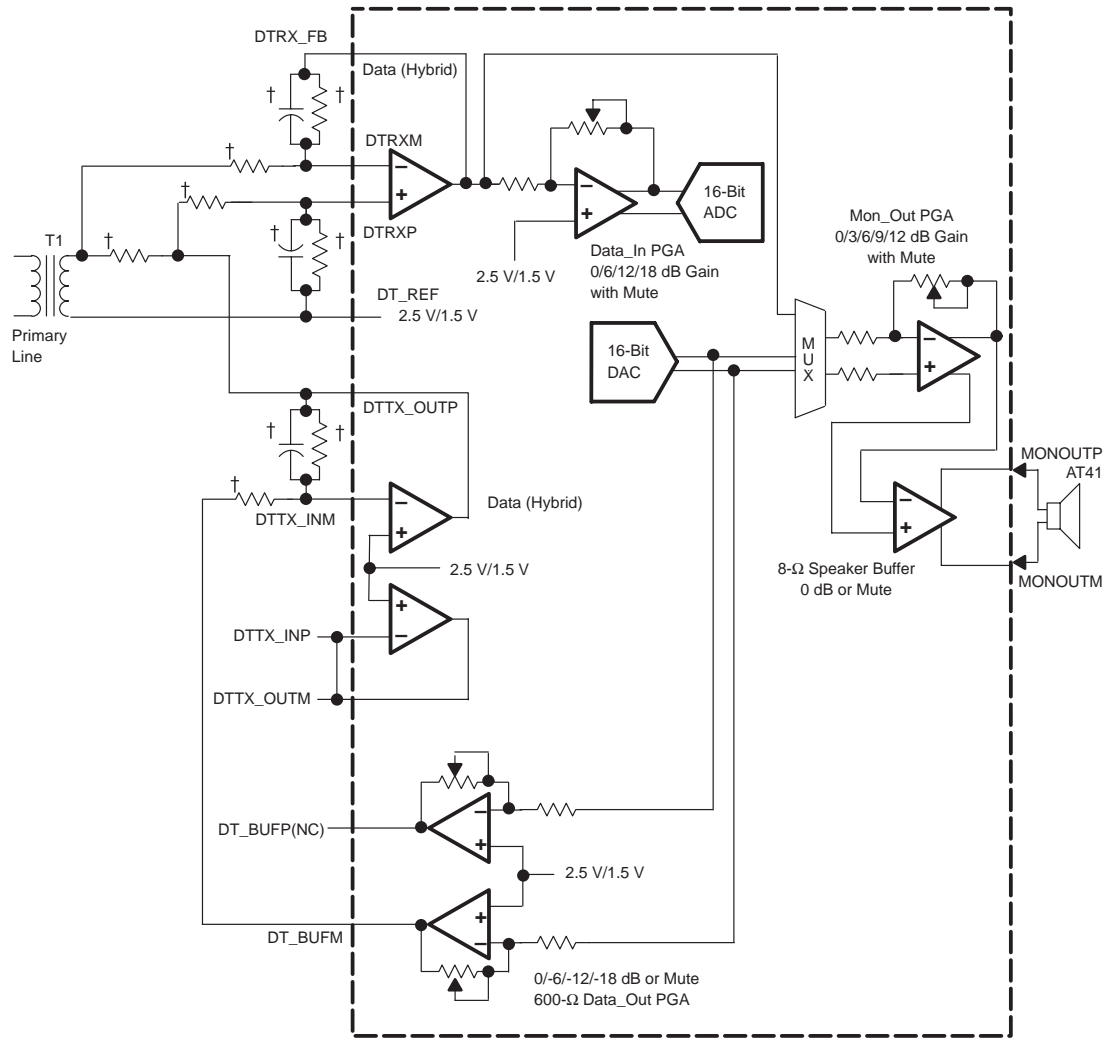

Figure 6–1. Functional Block of a Typical Application



† Required to meet communication standards

Figure 6–2. Differential Configuration Typical Application



† Required to meet communication standards

Figure 6-3. Single-Ended Configuration Typical Application

Appendix A

Programmable Register Set

Bits D12–D8 in a secondary serial communication comprise the address of the register that is written with data carried in bits D7–D0. D13 determines a read or write cycle to the addressed register. When low (0), a write cycle is selected. The following table shows the register map.

Table A–1. Register Map

REGISTER NO.	D15	D14	D13	D12	D11	D10	D9	D8	REGISTER NAME
1	0	0	R/W	0	0	0	0	1	Control 1
2	0	0	R/W	0	0	0	1	0	Control 2

Table A–2. Control Register 1

D7	D6	D5	D4	D3	D2	D1	D0	DESCRIPTION
1	—	—	—	—	—	—	—	Software reset asserted
0	—	—	—	—	—	—	—	Software reset not asserted
—	1	—	—	—	—	—	—	S/W power down enabled
—	0	—	—	—	—	—	—	S/W power down disabled
—	—	1	—	—	—	—	—	Digital loopback asserted
—	—	0	—	—	—	—	—	Digital loopback not asserted
—	—	—	1	—	—	—	—	Analog loopback asserted
—	—	—	0	—	—	—	—	Analog loopback not asserted
—	—	—	—	1	—	—	—	Select data_in PGA for monitor amp input
—	—	—	—	0	—	—	—	Select DAC output for monitor amp input
—	—	—	—	—	1	0	1	Monitor amp PGA gain = 12 dB
—	—	—	—	—	1	0	0	Monitor amp PGA gain = 9 dB
—	—	—	—	—	0	1	1	Monitor amp PGA gain = 6 dB
—	—	—	—	—	0	1	0	Monitor amp PGA gain = 3 dB
—	—	—	—	—	0	0	1	Monitor amp PGA gain = 0 dB
—	—	—	—	—	0	0	0	Monitor amp PGA gain = mute

Default value: 00000000

Table A-3. Control Register 2

D7	D6	D5	D4	D3	D2	D1	D0	DESCRIPTION
1	0	0	—	—	—	—	—	Data in (DTRX) PGA gain = mute
0	1	1	—	—	—	—	—	Data in (DTRX) PGA gain = 18 dB
0	1	0	—	—	—	—	—	Data in (DTRX) PGA gain = 12 dB
0	0	1	—	—	—	—	—	Data in (DTRX) PGA gain = 6 dB
0	0	0	—	—	—	—	—	Data in (DTRX) PGA gain = 0 dB
—	—	—	1	0	0	—	—	DAC data out PGA gain = mute
—	—	—	0	1	1	—	—	DAC data out PGA gain = -18 dB
—	—	—	0	1	0	—	—	DAC data out PGA gain = -12 dB
—	—	—	0	0	1	—	—	DAC data out PGA gain = -6 dB
—	—	—	0	0	0	—	—	DAC data out PGA gain = 0 dB
—	—	—	—	—	—	1	—	8 Ω monitor speaker driver gain = 0 dB
—	—	—	—	—	—	0	—	8 Ω monitor speaker driver gain = mute
—	—	—	—	—	—	—	X	ADC overflow indicator: ← 1 = overflow

Default value: 00000000

PACKAGING INFORMATION

Orderable Device	Status (1)	Package Type	Package Drawing	Pins	Package Qty	Eco Plan (2)	Lead finish/ Ball material (6)	MSL Peak Temp (3)	Op Temp (°C)	Device Marking (4/5)	Samples
TLC320AD545IPT	ACTIVE	LQFP	PT	48	250	RoHS & Green	NIPDAU	Level-1-260C-UNLIM	-40 to 85	320AD545I	Samples
TLC320AD545PTR	ACTIVE	LQFP	PT	48	1000	RoHS & Green	NIPDAU	Level-1-260C-UNLIM	0 to 70	320AD545	Samples

(1) The marketing status values are defined as follows:

ACTIVE: Product device recommended for new designs.

LIFEBUY: TI has announced that the device will be discontinued, and a lifetime-buy period is in effect.

NRND: Not recommended for new designs. Device is in production to support existing customers, but TI does not recommend using this part in a new design.

PREVIEW: Device has been announced but is not in production. Samples may or may not be available.

OBSOLETE: TI has discontinued the production of the device.

(2) **RoHS:** TI defines "RoHS" to mean semiconductor products that are compliant with the current EU RoHS requirements for all 10 RoHS substances, including the requirement that RoHS substance do not exceed 0.1% by weight in homogeneous materials. Where designed to be soldered at high temperatures, "RoHS" products are suitable for use in specified lead-free processes. TI may reference these types of products as "Pb-Free".

RoHS Exempt: TI defines "RoHS Exempt" to mean products that contain lead but are compliant with EU RoHS pursuant to a specific EU RoHS exemption.

Green: TI defines "Green" to mean the content of Chlorine (Cl) and Bromine (Br) based flame retardants meet JS709B low halogen requirements of <=1000ppm threshold. Antimony trioxide based flame retardants must also meet the <=1000ppm threshold requirement.

(3) MSL, Peak Temp. - The Moisture Sensitivity Level rating according to the JEDEC industry standard classifications, and peak solder temperature.

(4) There may be additional marking, which relates to the logo, the lot trace code information, or the environmental category on the device.

(5) Multiple Device Markings will be inside parentheses. Only one Device Marking contained in parentheses and separated by a "~" will appear on a device. If a line is indented then it is a continuation of the previous line and the two combined represent the entire Device Marking for that device.

(6) Lead finish/Ball material - Orderable Devices may have multiple material finish options. Finish options are separated by a vertical ruled line. Lead finish/Ball material values may wrap to two lines if the finish value exceeds the maximum column width.

Important Information and Disclaimer:The information provided on this page represents TI's knowledge and belief as of the date that it is provided. TI bases its knowledge and belief on information provided by third parties, and makes no representation or warranty as to the accuracy of such information. Efforts are underway to better integrate information from third parties. TI has taken and continues to take reasonable steps to provide representative and accurate information but may not have conducted destructive testing or chemical analysis on incoming materials and chemicals. TI and TI suppliers consider certain information to be proprietary, and thus CAS numbers and other limited information may not be available for release.

In no event shall TI's liability arising out of such information exceed the total purchase price of the TI part(s) at issue in this document sold by TI to Customer on an annual basis.

TAPE AND REEL INFORMATION

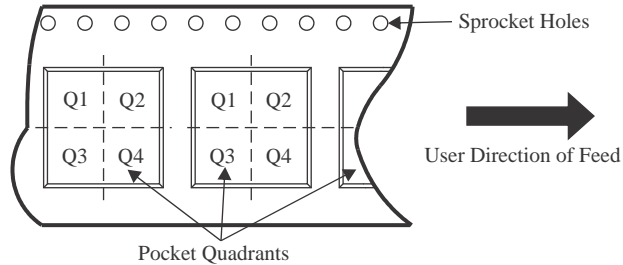
QUADRANT ASSIGNMENTS FOR PIN 1 ORIENTATION IN TAPE

*All dimensions are nominal

Device	Package Type	Package Drawing	Pins	SPQ	Reel Diameter (mm)	Reel Width W1 (mm)	A0 (mm)	B0 (mm)	K0 (mm)	P1 (mm)	W (mm)	Pin1 Quadrant
TLC320AD545PTR	LQFP	PT	48	1000	330.0	16.4	9.6	9.6	1.9	12.0	16.0	Q2

TAPE AND REEL BOX DIMENSIONS

*All dimensions are nominal

Device	Package Type	Package Drawing	Pins	SPQ	Length (mm)	Width (mm)	Height (mm)
TLC320AD545PTR	LQFP	PT	48	1000	350.0	350.0	43.0

TRAY

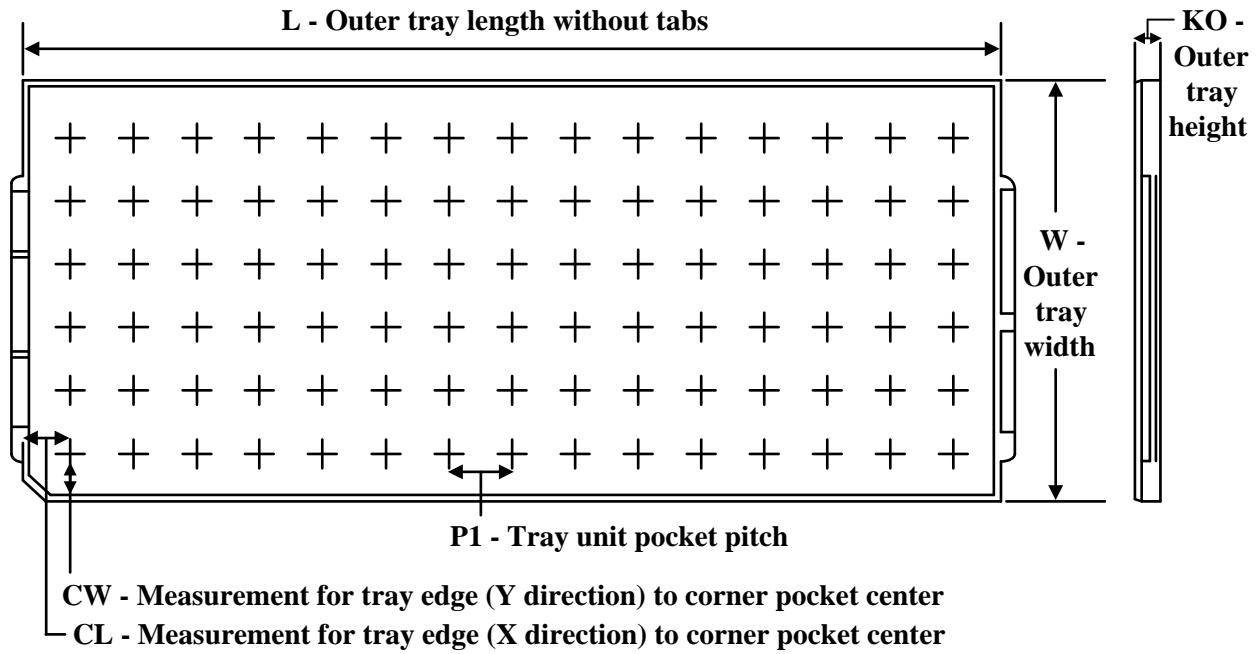

Chamfer on Tray corner indicates Pin 1 orientation of packed units.

*All dimensions are nominal

Device	Package Name	Package Type	Pins	SPQ	Unit array matrix	Max temperature (°C)	L (mm)	W (mm)	K0 (µm)	P1 (mm)	CL (mm)	CW (mm)
TLC320AD545IPT	PT	LQFP	48	250	10 x 25	150	315	135.9	7620	12.2	11.1	11.25

IMPORTANT NOTICE AND DISCLAIMER

TI PROVIDES TECHNICAL AND RELIABILITY DATA (INCLUDING DATA SHEETS), DESIGN RESOURCES (INCLUDING REFERENCE DESIGNS), APPLICATION OR OTHER DESIGN ADVICE, WEB TOOLS, SAFETY INFORMATION, AND OTHER RESOURCES "AS IS" AND WITH ALL FAULTS, AND DISCLAIMS ALL WARRANTIES, EXPRESS AND IMPLIED, INCLUDING WITHOUT LIMITATION ANY IMPLIED WARRANTIES OF MERCHANTABILITY, FITNESS FOR A PARTICULAR PURPOSE OR NON-INFRINGEMENT OF THIRD PARTY INTELLECTUAL PROPERTY RIGHTS.

These resources are intended for skilled developers designing with TI products. You are solely responsible for (1) selecting the appropriate TI products for your application, (2) designing, validating and testing your application, and (3) ensuring your application meets applicable standards, and any other safety, security, regulatory or other requirements.

These resources are subject to change without notice. TI grants you permission to use these resources only for development of an application that uses the TI products described in the resource. Other reproduction and display of these resources is prohibited. No license is granted to any other TI intellectual property right or to any third party intellectual property right. TI disclaims responsibility for, and you will fully indemnify TI and its representatives against, any claims, damages, costs, losses, and liabilities arising out of your use of these resources.

TI's products are provided subject to [TI's Terms of Sale](#) or other applicable terms available either on [ti.com](https://www.ti.com) or provided in conjunction with such TI products. TI's provision of these resources does not expand or otherwise alter TI's applicable warranties or warranty disclaimers for TI products.

TI objects to and rejects any additional or different terms you may have proposed.

Mailing Address: Texas Instruments, Post Office Box 655303, Dallas, Texas 75265
Copyright © 2023, Texas Instruments Incorporated

Looking for pricing, stock, or lifecycle information?

Click below to explore more details on WIN SOURCE:

 [View TLC320AD545IPT](#) on WIN SOURCE

 [Texas Instruments](#) Information

Optimize Your Supply Chain with WIN SOURCE Solutions

-  Global Sourcing Solution
-  Obsolete Management
-  Cost Control Management
-  Shortage Management
-  Alternative Solution
-  Excess Inventory Management