



THE DATASHEET OF TL441CNSR



- Excellent Dynamic Range
- Wide Bandwidth
- Built-In Temperature Compensation
- Log Linearity (30-dB Sections) . . . 1 dB Typ
- Wide Input Voltage Range

description

This amplifier circuit contains four 30-dB logarithmic stages. Gain in each stage is such that the output of each stage is proportional to the logarithm of the input voltage over the 30-dB input voltage range. Each half of the circuit contains two of these 30-dB stages summed together in one differential output that is proportional to the sum of the logarithms of the input voltages of the two stages. The four stages may be interconnected to obtain a theoretical input voltage range of 120-dB. In practice, this permits the input voltage range typically to be greater than 80-dB with log linearity of ± 0.5 -dB (see application data). Bandwidth is from dc to 40 MHz.

This circuit is useful in data compression and analog compensation. This logarithmic amplifier is used in log IF circuitry as well as video and log amplifiers.

The TL441 is characterized for operation over 0°C to 70°C.

N PACKAGE
(TOP VIEW)

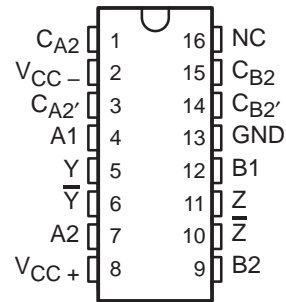

NC — No internal connection



Please be aware that an important notice concerning availability, standard warranty, and use in critical applications of Texas Instruments semiconductor products and disclaimers thereto appears at the end of this data sheet.

PRODUCTION DATA information is current as of publication date. Products conform to specifications per the terms of Texas Instruments standard warranty. Production processing does not necessarily include testing of all parameters.

 **TEXAS
INSTRUMENTS**

POST OFFICE BOX 655303 • DALLAS, TEXAS 75265

Copyright © 2000, Texas Instruments Incorporated

TL441 LOGARITHMIC AMPLIFIER

SLVS328 – OCTOBER 2000

functional logic diagram (one half)

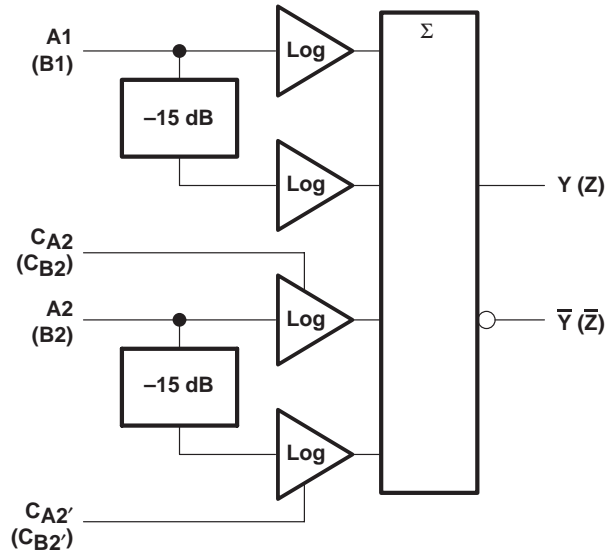

$Y \propto \log A1 + \log A2$; $Z \propto \log B1 + \log B2$ where: A1, A2, B1, and B2 are in dBV, 0 dBV = 1 V.
CA2, CA2', CB2, and CB2' are detector compensation inputs.

schematic

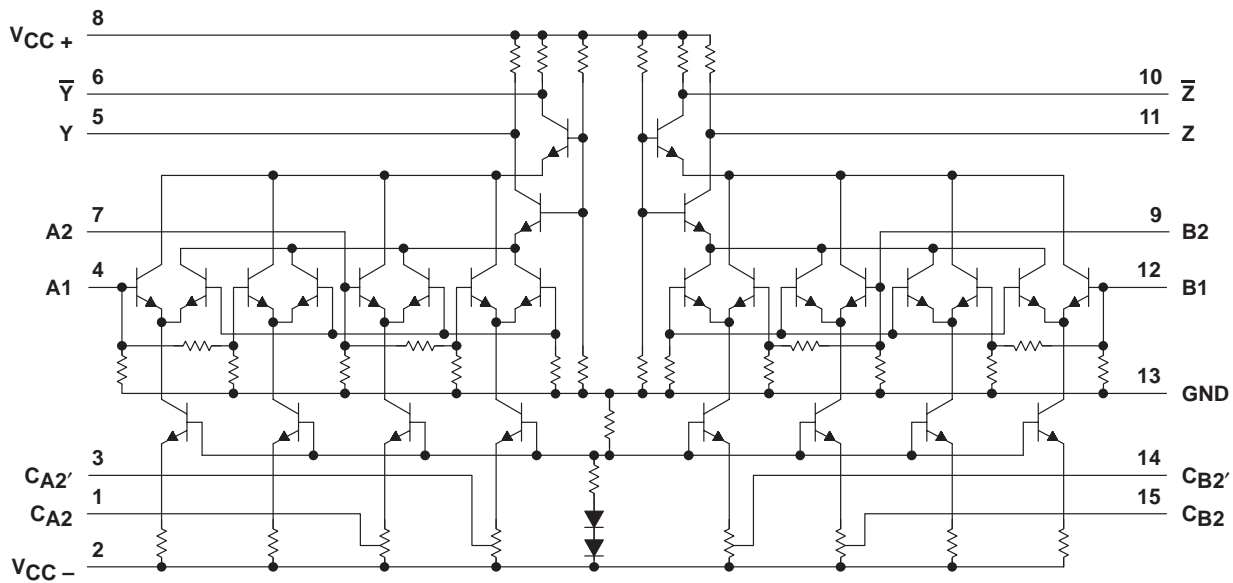

absolute maximum ratings over operating free-air temperature range (unless otherwise noted)†

Supply voltages (see Note 1): V_{CC+}	8 V
V_{CC-}	-8 V
Input voltage (see Note 1)	6 V
Output sink current (any one output)	30 mA
Package thermal impedance, θ_{JA} (see Notes 2 and 3)	67°C/W
Lead temperature 1,6 mm (1/16 inch) from case for 10 seconds	260°C
Storage temperature range, T_{stg}	-65°C to 150°C

† Stresses beyond those listed under “absolute maximum ratings” may cause permanent damage to the device. These are stress ratings only, and functional operation of the device at these or any other conditions beyond those indicated under “recommended operating conditions” is not implied. Exposure to absolute-maximum-rated conditions for extended periods may affect device reliability.

- NOTES:
1. All voltages, except differential out voltages, are with respect to network ground terminal.
 2. Maximum power dissipation is a function of $T_J(\max)$, θ_{JA} , and T_A . The maximum allowable power dissipation at any allowable ambient temperature is $P_D = (T_J(\max) - T_A)/\theta_{JA}$. Operating at the absolute maximum T_J of 150°C can affect reliability.
 3. The package thermal impedance is calculated in accordance with JESD 51-7.

recommended operating conditions

	MIN	MAX	UNIT
Peak-to-peak input voltage for each 30-dB stage	0.01	1	V
Operating free-air temperature, T_A	0	70	°C

electrical characteristics, $V_{CC\pm} = \pm 6$ V, $T_A = 25^\circ\text{C}$

PARAMETER	TEST FIGURE	MIN	TYP	MAX	UNIT
Differential output offset voltage	1		±40		mV
Quiescent output voltage	2	5.45	5.6	5.85	V
DC scale factor (differential output), each 3-dB stage, -35 dBV to -5 dBV	3	6	8	12	mV/dB
AC scale factor (differential output)			8		mV/dB
DC error at -20 dBV (midpoint of -35 dBV to -5 dBV range)	3		1		dB
Input impedance			500		Ω
Output impedance			200		Ω
Rise time, 10% to 90% points, $C_L = 24$ pF	4		20	30	ns
Supply current from V_{CC+}	2	14.5	18.5	23	mA
Supply current from V_{CC-}	2	-6	-8.5	-10.5	mA
Power dissipation	2	123	162	201	mW

TL441 LOGARITHMIC AMPLIFIER

SLVS328 – OCTOBER 2000

PARAMETER MEASUREMENT INFORMATION

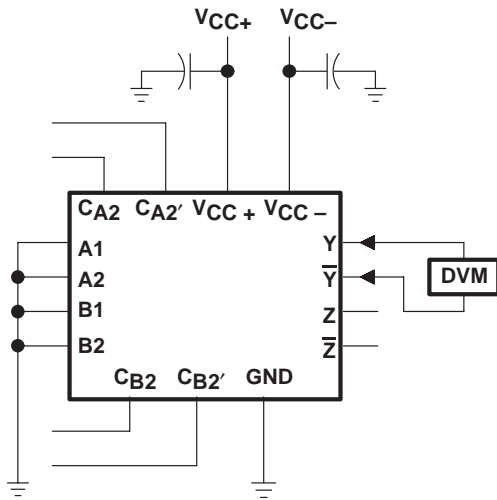

Figure 1

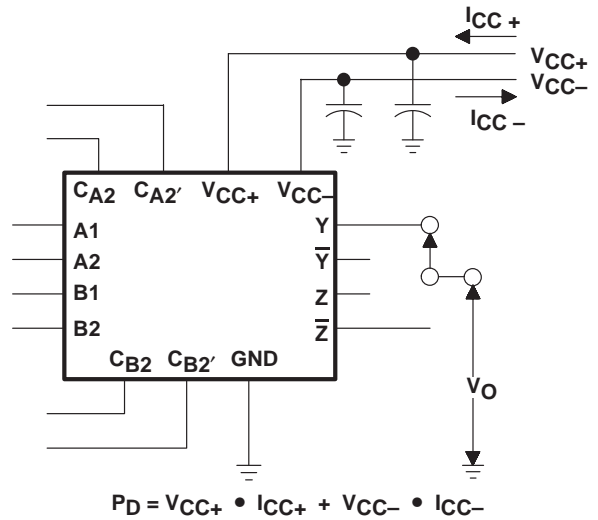

Figure 2

PARAMETER MEASUREMENT INFORMATION

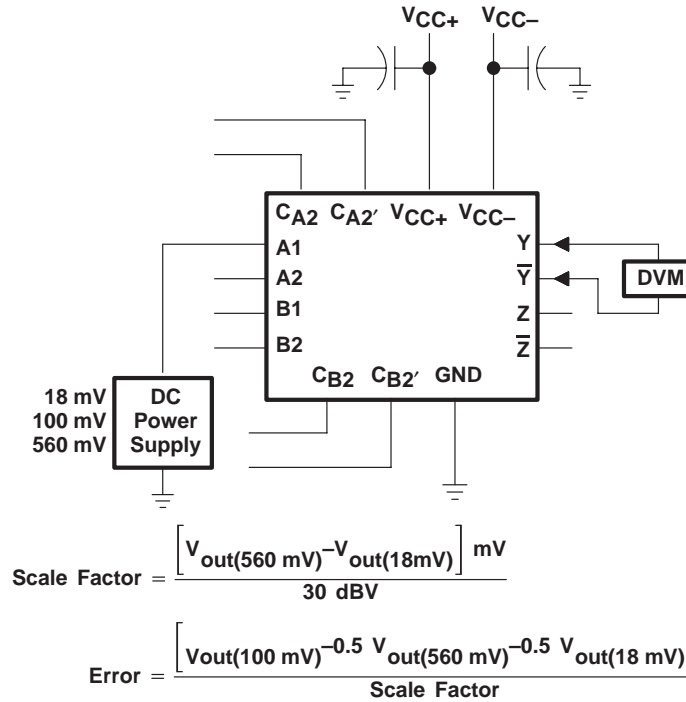
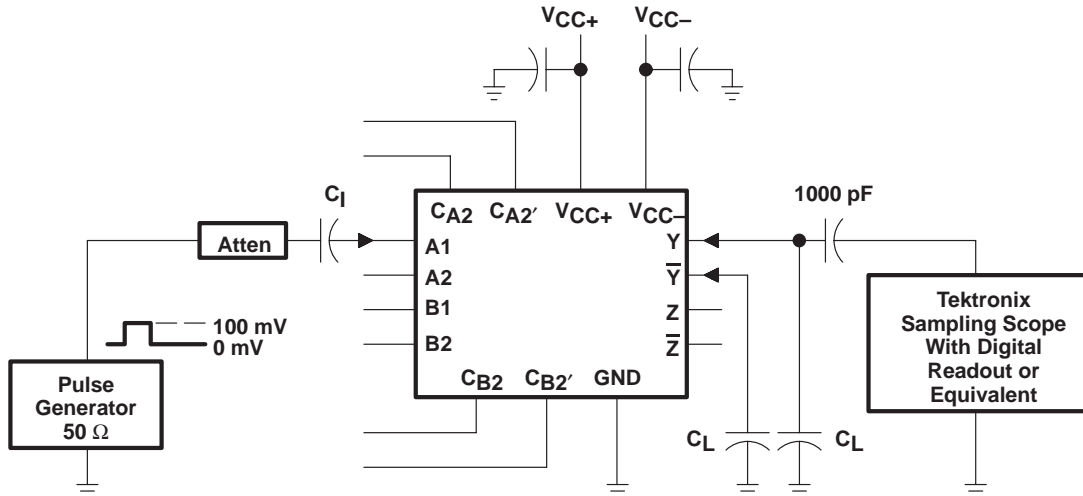

Figure 3



- NOTES: A. The input pulse has the following characteristics: $t_w = 200 \text{ ns}$, $t_r \leq 2 \text{ ns}$, $t_f \leq 2 \text{ ns}$, $\text{PRR} \leq 10 \text{ MHz}$.
 B. Capacitor C_1 consists of three capacitors in parallel: $1 \mu\text{F}$, $0.1 \mu\text{F}$, and $0.01 \mu\text{F}$.
 C. C_L includes probe and jig capacitance.

Figure 4

TYPICAL CHARACTERISTICS†

DIFFERENTIAL OUTPUT OFFSET VOLTAGE
vs
FREE-AIR TEMPERATURE

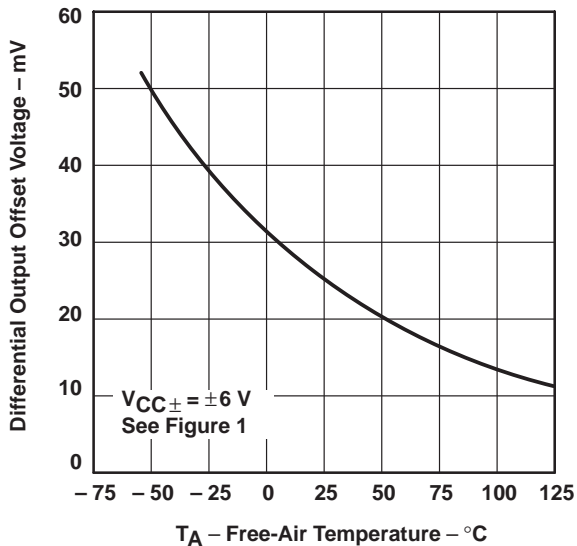

Figure 5

QUIESCENT OUTPUT VOLTAGE
vs
FREE-AIR TEMPERATURE

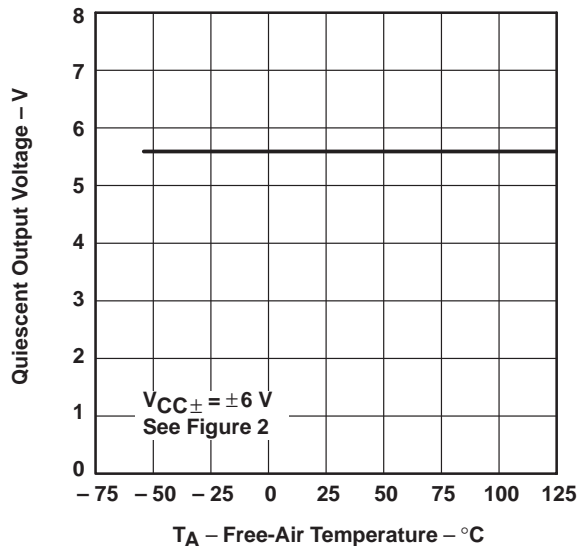

Figure 6

DC SCALE FACTOR
vs
FREE-AIR TEMPERATURE

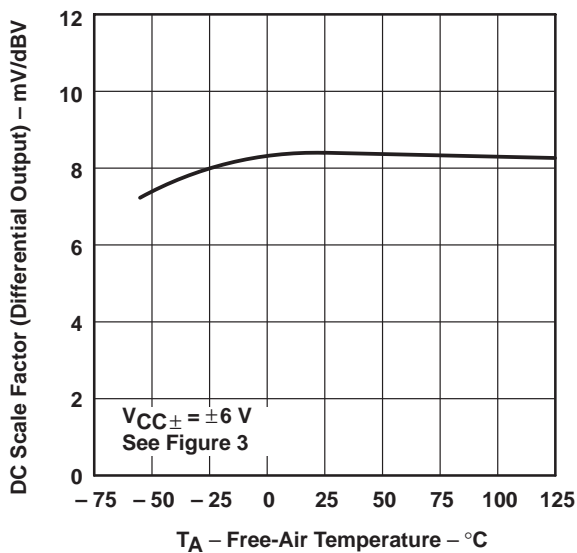

Figure 7

DC ERROR
vs
FREE-AIR TEMPERATURE

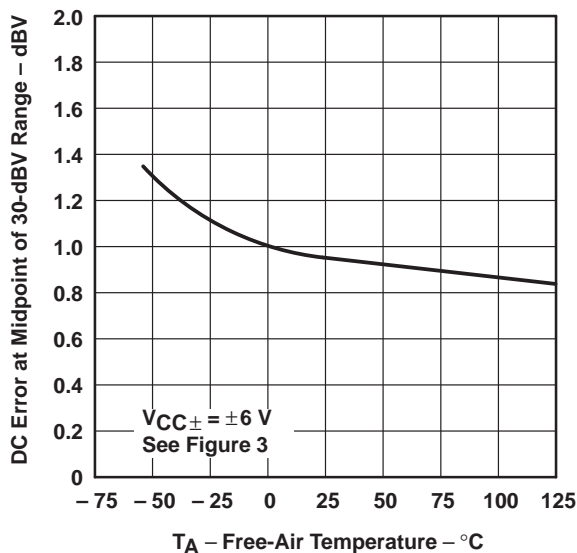

Figure 8

† Data at high and low temperatures are applicable only within the recommended operating free-air temperature ranges of the various devices.

TYPICAL CHARACTERISTICS

OUTPUT RISE TIME
VS
LOAD CAPACITANCE

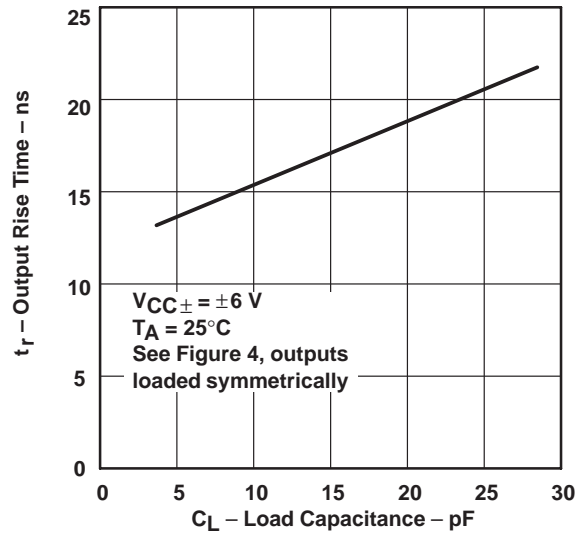

Figure 9

TL441 LOGARITHMIC AMPLIFIER

SLVS328 – OCTOBER 2000

APPLICATION INFORMATION

Although designed for high-performance applications such as infrared detection, this device has a wide range of applications in data compression and analog computation.

basic logarithmic function

The basic logarithmic response is derived from the exponential current-voltage relationship of collector current and base-emitter voltage. This relationship is given in the equation:

$$m \cdot V_{BE} = \ln [(I_C + I_{CES})/I_{CES}]$$

where:

I_C = collector current

I_{CES} = collector current at $V_{BE} = 0$

m = q/kT (in V^{-1})

V_{BE} = base-emitter voltage

The differential input amplifier allows dual-polarity inputs, is self-compensating for temperature variations, and is relatively insensitive to common-mode noise.

functional block diagram

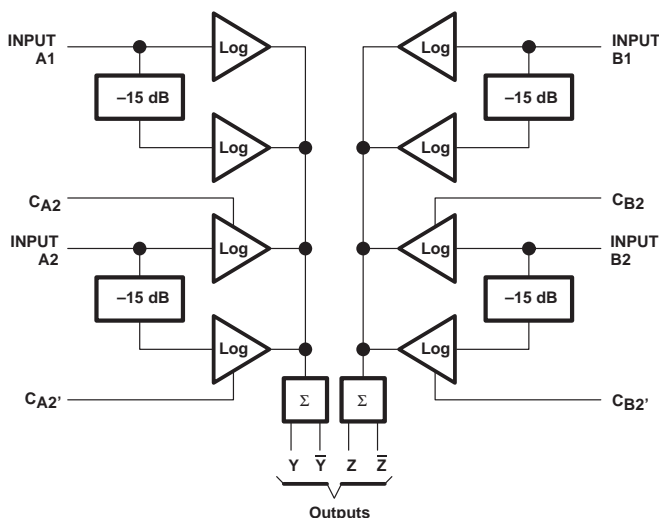

Figure 10

logarithmic sections

As can be seen from the schematic, there are eight differential pairs. Each pair is a 15-dB log subsection, and each input feeds two pairs, for a range of 30-dB per stage.

Four compensation points are available to allow slight variations in the gain (slope) of the two individual 15-dB stages of input A2 and B2. By slightly changing the voltage on any of the compensation pins from their quiescent values, the gain of that particular 15-dB stage can be adjusted to match the other 15-dB stage in the pair. The compensation pins also can be used to match the transfer characteristics of input A2 to A1 or B2 to B1.

The log stages in each half of the circuit are summed by directly connecting their collectors together and summing through a common-base output stage. The two sets of output collectors are used to give two log outputs, Y and \bar{Y} (or Z and \bar{Z}), which are equal in amplitude, but opposite in polarity. This increases the versatility of the device.

By proper choice of external connections, linear amplification, and linear attenuation, and many different applications requiring logarithmic signal processing are possible.

input levels

The recommended input voltage range of any one stage is given as 0.01 V to 1 V. Input levels in excess of 1 V may result in a distorted output. When several log sections are summed together, the distorted area of one section overlaps with the next section and the resulting distortion is insignificant. However, there is a limit to the amount of overdrive that can be applied. As the input drive reaches ± 3.5 V, saturation occurs, clamping the collector-summing line and severely distorting the output. Therefore, the signal to any input must be limited to approximately ± 3 V to ensure a clean output.

APPLICATION INFORMATION

output levels

Differential-output-voltage levels are low, generally less than 0.6 V. As demonstrated in Figure 12, the output swing and the slope of the output response can be adjusted by varying the gain by means of the slope control. The coordinate origin also can be adjusted by positioning the offset of the output buffer.

circuits

Figures 12 through 19 show typical circuits using this logarithmic amplifier. Operational amplifiers not otherwise designated are TLC271. For operation at higher frequencies, the TL592 is recommended instead of the TLC271.

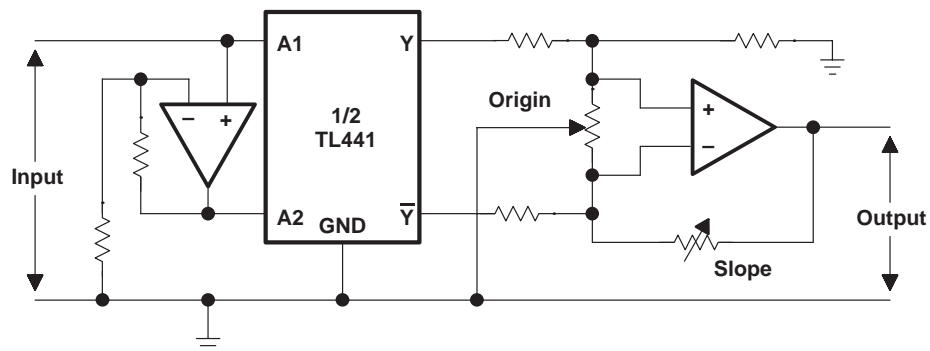
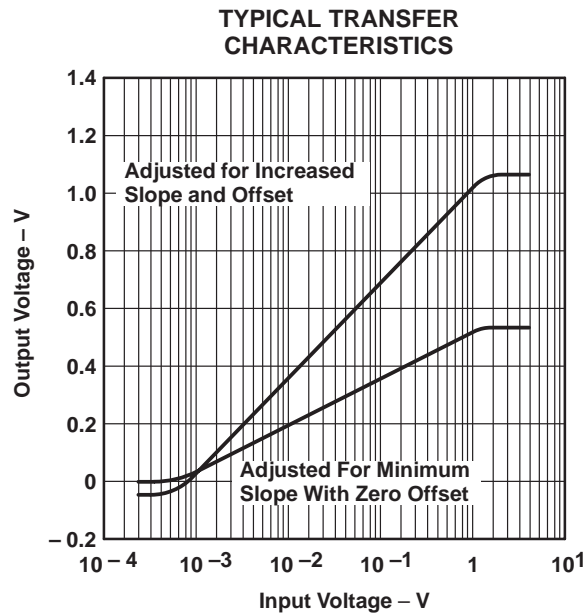

Figure 12. Output Slope and Origin Adjustment

APPLICATION INFORMATION

TRANSFER CHARACTERISTICS
OF TWO TYPICAL INPUT STAGES

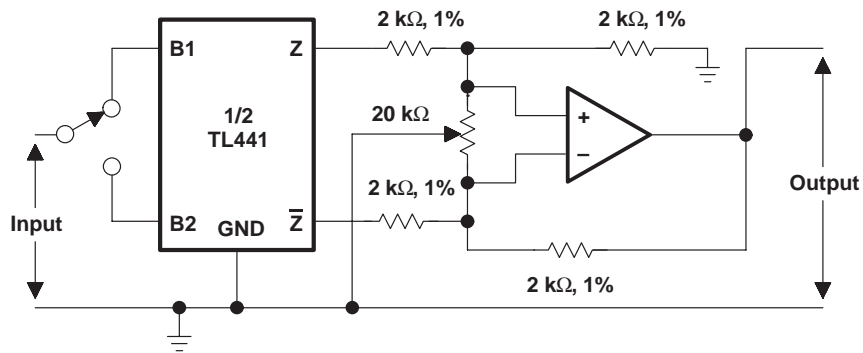
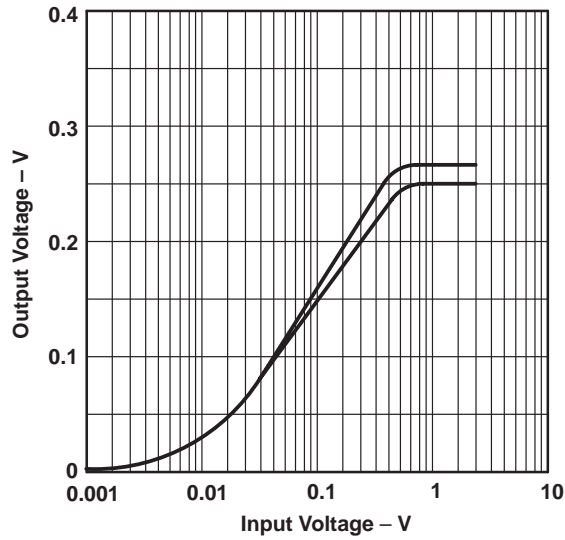

Figure 13. Utilization of Separate Stages

APPLICATION INFORMATION

TRANSFER CHARACTERISTICS
WITH BOTH SIDES PARALLELED

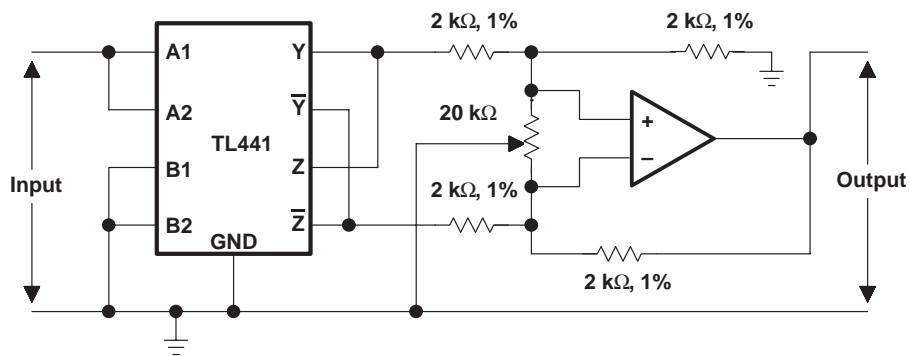
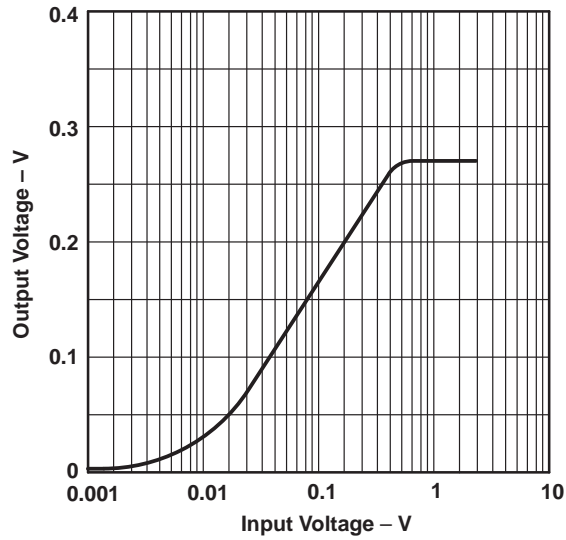
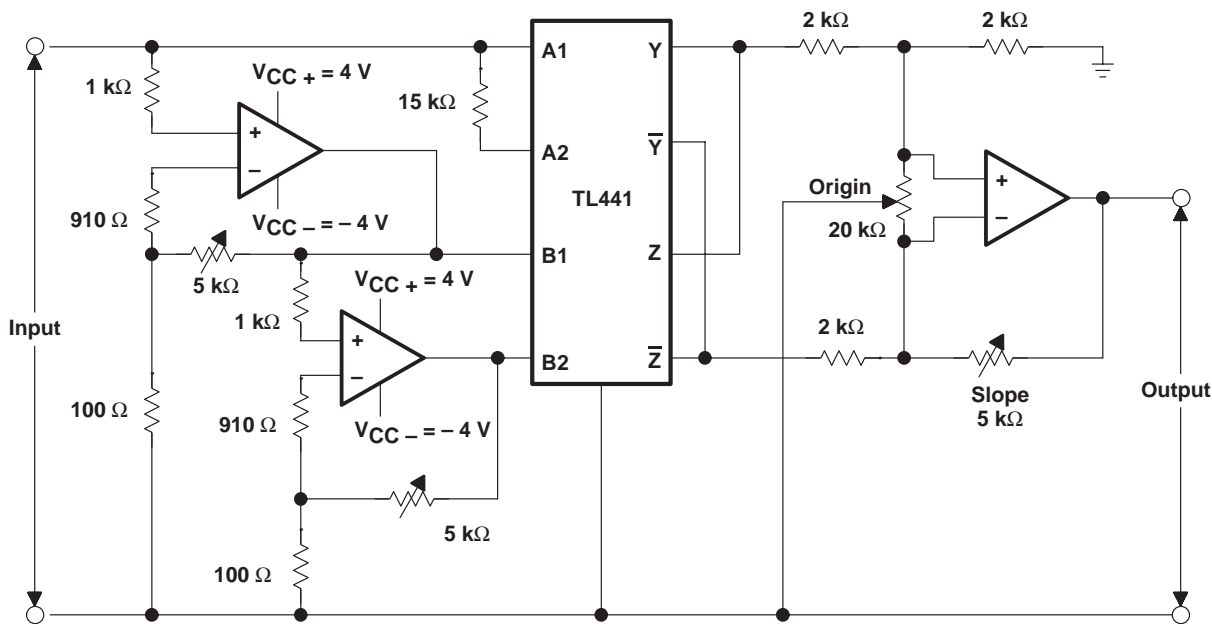
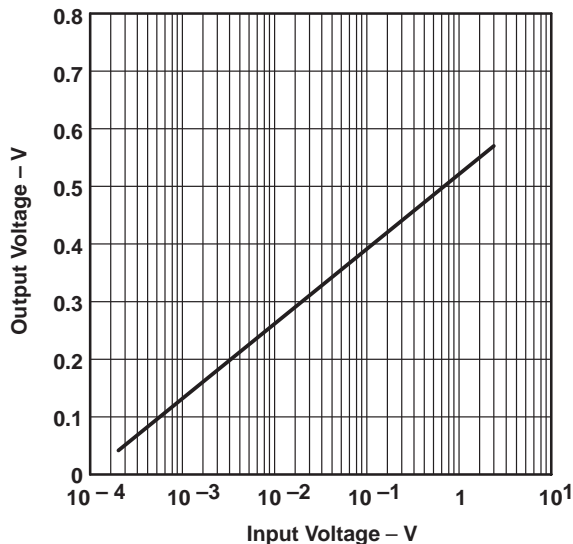

Figure 14. Utilization of Paralleled Inputs

APPLICATION INFORMATION

TRANSFER CHARACTERISTICS



- NOTES: A. Inputs are limited by reducing the supply voltages for the input amplifiers to ± 4 V.
B. The gains of the input amplifiers are adjusted to achieve smooth transitions.

Figure 15. Logarithmic Amplifier With Input Voltage Range Greater Than 80 dB

APPLICATION INFORMATION

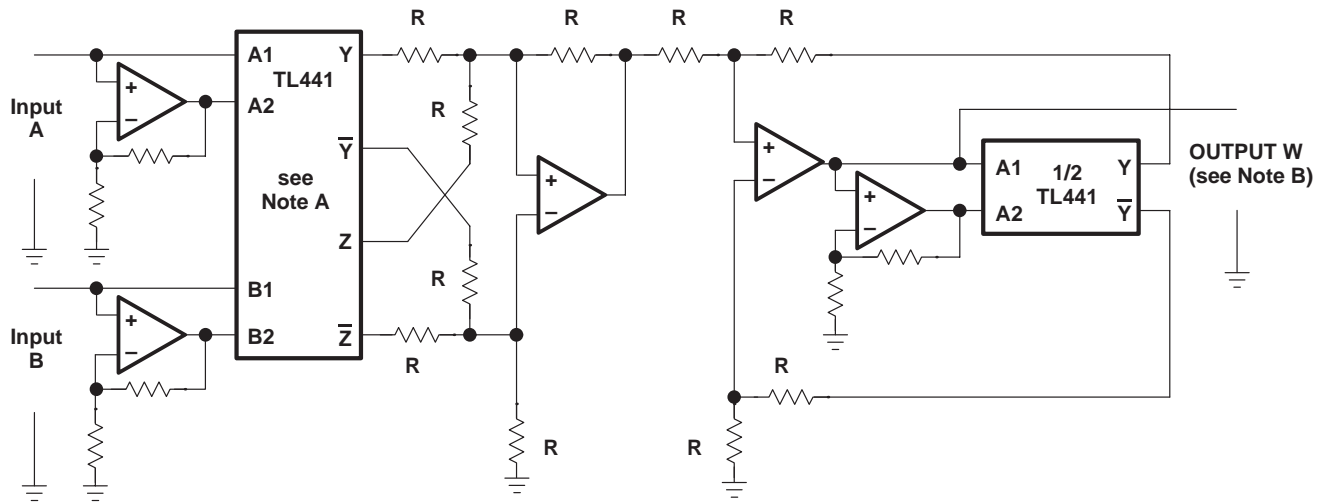

- NOTES: A. Connections shown are for multiplication. For division, Z and \bar{Z} connections are reversed.
 B. Output W may need to be amplified to give actual product or quotient of A and B.
 C. R designates resistors of equal value, typically 2 kΩ to 10 kΩ.

Multiplication: $W = A \cdot B \Rightarrow \log W = \log A + \log B$, or $W = a^{(\log_a A + \log_a B)}$

Division: $W = A/B \Rightarrow \log W = \log A - \log B$, or $W = a^{(\log_a A - \log_a B)}$

Figure 16. Multiplication or Division

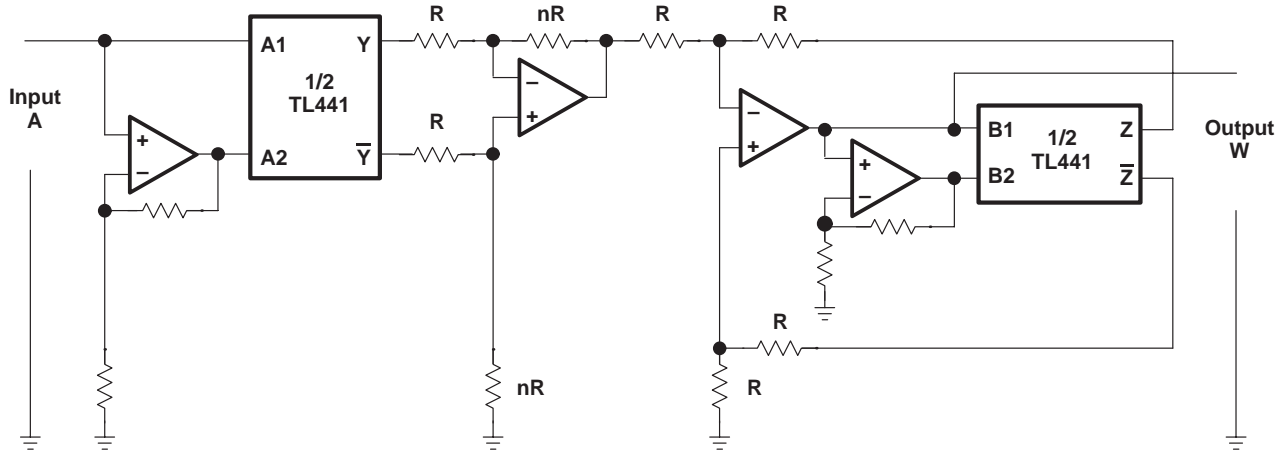

NOTE: R designates resistors of equal value, typically 2 kΩ to 10 kΩ. The power to which the input variable is raised is fixed by setting nR. Output W may need to be amplified to give the correct value.

Exponential: $W = A^n \Rightarrow \log W = n \log A$, or $W = a^{(n \log_a A)}$

Figure 17. Raising a Variable to a Fixed Power

APPLICATION INFORMATION

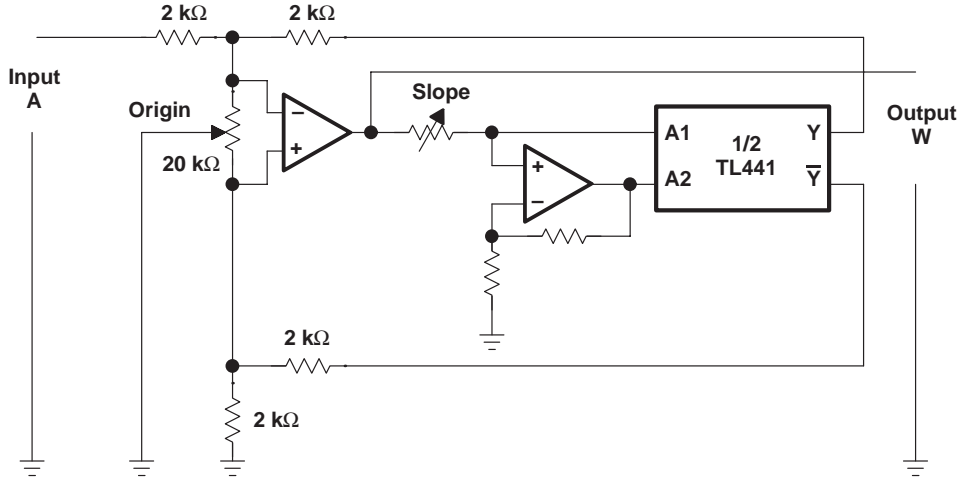

NOTE: Adjust the slope to correspond to the base "a".
Exponential to any base: $W = a$.

Figure 18. Raising a Fixed Number to a Variable Power

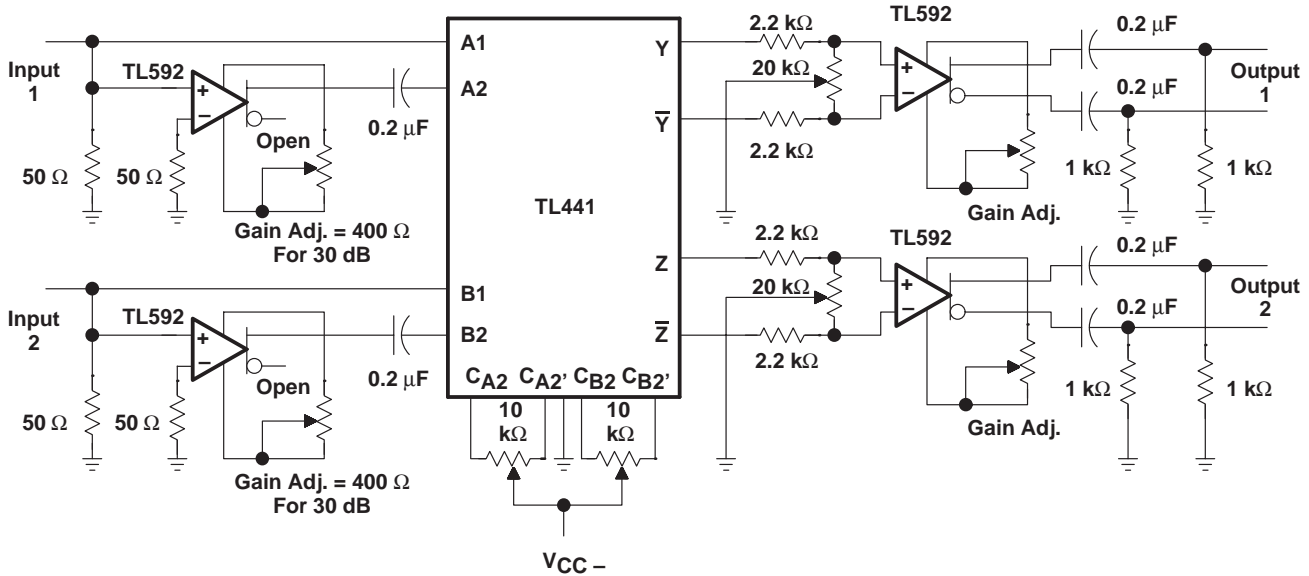

Figure 19. Dual-Channel RF Logarithmic Amplifier With 50-dB Input Range Per Channel at 10 MHz

PACKAGING INFORMATION

Orderable Device	Status (1)	Package Type	Package Drawing	Pins	Package Qty	Eco Plan (2)	Lead finish/ Ball material (6)	MSL Peak Temp (3)	Op Temp (°C)	Device Marking (4/5)	Samples
TL441CN	ACTIVE	PDIP	N	16	25	RoHS & Green	NIPDAU	N / A for Pkg Type	0 to 70	TL441CN	Samples
TL441CNSR	ACTIVE	SO	NS	16	2000	RoHS & Green	NIPDAU	Level-1-260C-UNLIM	0 to 70	TL441	Samples

(1) The marketing status values are defined as follows:

ACTIVE: Product device recommended for new designs.

LIFEBUY: TI has announced that the device will be discontinued, and a lifetime-buy period is in effect.

NRND: Not recommended for new designs. Device is in production to support existing customers, but TI does not recommend using this part in a new design.

PREVIEW: Device has been announced but is not in production. Samples may or may not be available.

OBsolete: TI has discontinued the production of the device.

(2) **RoHS:** TI defines "RoHS" to mean semiconductor products that are compliant with the current EU RoHS requirements for all 10 RoHS substances, including the requirement that RoHS substance do not exceed 0.1% by weight in homogeneous materials. Where designed to be soldered at high temperatures, "RoHS" products are suitable for use in specified lead-free processes. TI may reference these types of products as "Pb-Free".

RoHS Exempt: TI defines "RoHS Exempt" to mean products that contain lead but are compliant with EU RoHS pursuant to a specific EU RoHS exemption.

Green: TI defines "Green" to mean the content of Chlorine (Cl) and Bromine (Br) based flame retardants meet JS709B low halogen requirements of <=1000ppm threshold. Antimony trioxide based flame retardants must also meet the <=1000ppm threshold requirement.

(3) MSL, Peak Temp. - The Moisture Sensitivity Level rating according to the JEDEC industry standard classifications, and peak solder temperature.

(4) There may be additional marking, which relates to the logo, the lot trace code information, or the environmental category on the device.

(5) Multiple Device Markings will be inside parentheses. Only one Device Marking contained in parentheses and separated by a "~" will appear on a device. If a line is indented then it is a continuation of the previous line and the two combined represent the entire Device Marking for that device.

(6) Lead finish/Ball material - Orderable Devices may have multiple material finish options. Finish options are separated by a vertical ruled line. Lead finish/Ball material values may wrap to two lines if the finish value exceeds the maximum column width.

Important Information and Disclaimer:The information provided on this page represents TI's knowledge and belief as of the date that it is provided. TI bases its knowledge and belief on information provided by third parties, and makes no representation or warranty as to the accuracy of such information. Efforts are underway to better integrate information from third parties. TI has taken and continues to take reasonable steps to provide representative and accurate information but may not have conducted destructive testing or chemical analysis on incoming materials and chemicals. TI and TI suppliers consider certain information to be proprietary, and thus CAS numbers and other limited information may not be available for release.

In no event shall TI's liability arising out of such information exceed the total purchase price of the TI part(s) at issue in this document sold by TI to Customer on an annual basis.

OTHER QUALIFIED VERSIONS OF TL441 :

- Enhanced Product: [TL441-EP](#)

NOTE: Qualified Version Definitions:

- Enhanced Product - Supports Defense, Aerospace and Medical Applications

TAPE AND REEL INFORMATION

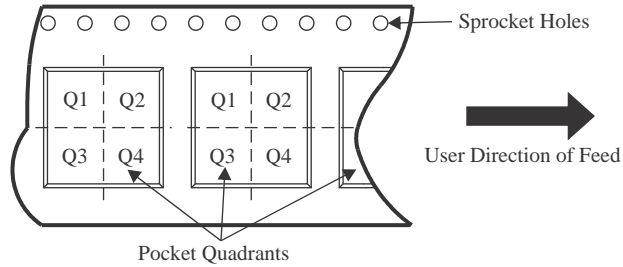
QUADRANT ASSIGNMENTS FOR PIN 1 ORIENTATION IN TAPE

*All dimensions are nominal

Device	Package Type	Package Drawing	Pins	SPQ	Reel Diameter (mm)	Reel Width W1 (mm)	A0 (mm)	B0 (mm)	K0 (mm)	P1 (mm)	W (mm)	Pin1 Quadrant
TL441CNSR	SO	NS	16	2000	330.0	16.4	8.1	10.4	2.5	12.0	16.0	Q1

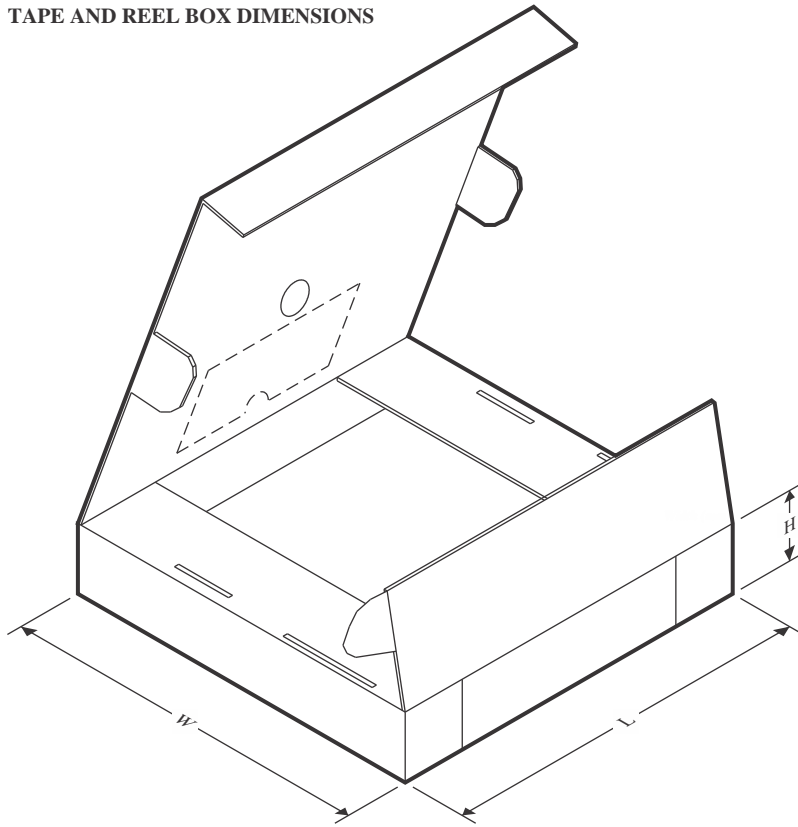
TAPE AND REEL BOX DIMENSIONS

*All dimensions are nominal

Device	Package Type	Package Drawing	Pins	SPQ	Length (mm)	Width (mm)	Height (mm)
TL441CNSR	SO	NS	16	2000	356.0	356.0	35.0

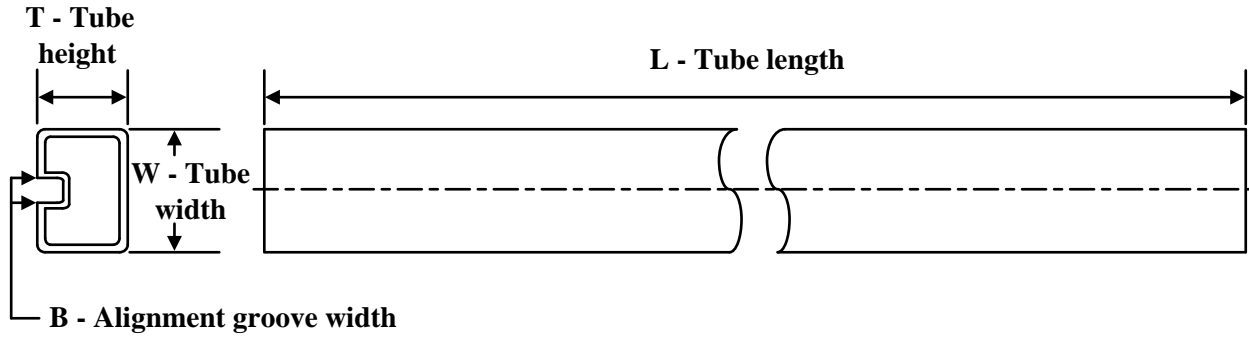
TUBE

*All dimensions are nominal

Device	Package Name	Package Type	Pins	SPQ	L (mm)	W (mm)	T (μm)	B (mm)
TL441CN	N	PDIP	16	25	506	13.97	11230	4.32



PACKAGE OUTLINE

NS0016A

SOP - 2.00 mm max height

SOP



4220735/A 12/2021

NOTES:

1. All linear dimensions are in millimeters. Dimensions in parenthesis are for reference only. Dimensioning and tolerancing per ASME Y14.5M.
2. This drawing is subject to change without notice.
3. This dimension does not include mold flash, protrusions, or gate burrs. Mold flash, protrusions, or gate burrs shall not exceed 0.15 mm, per side.
4. This dimension does not include interlead flash. Interlead flash shall not exceed 0.25 mm, per side.

EXAMPLE BOARD LAYOUT

NS0016A

SOP - 2.00 mm max height

SOP



SOLDER MASK DETAILS

4220735/A 12/2021

NOTES: (continued)

5. Publication IPC-7351 may have alternate designs.

6. Solder mask tolerances between and around signal pads can vary based on board fabrication site.

EXAMPLE STENCIL DESIGN

NS0016A

SOP - 2.00 mm max height

SOP



SOLDER PASTE EXAMPLE
BASED ON 0.125 mm THICK STENCIL
SCALE:7X

4220735/A 12/2021

NOTES: (continued)

7. Laser cutting apertures with trapezoidal walls and rounded corners may offer better paste release. IPC-7525 may have alternate design recommendations.
8. Board assembly site may have different recommendations for stencil design.

MECHANICAL DATA

NS (R-PDSO-G**)

PLASTIC SMALL-OUTLINE PACKAGE

14-PINS SHOWN



- NOTES:
- A. All linear dimensions are in millimeters.
 - B. This drawing is subject to change without notice.
 - C. Body dimensions do not include mold flash or protrusion, not to exceed 0,15.

N (R-PDIP-T**)

PLASTIC DUAL-IN-LINE PACKAGE

16 PINS SHOWN



4040049/E 12/2002

- NOTES:
- A. All linear dimensions are in inches (millimeters).
 - B. This drawing is subject to change without notice.
 - (C) Falls within JEDEC MS-001, except 18 and 20 pin minimum body length (Dim A).
 - (D) The 20 pin end lead shoulder width is a vendor option, either half or full width.

IMPORTANT NOTICE AND DISCLAIMER

TI PROVIDES TECHNICAL AND RELIABILITY DATA (INCLUDING DATA SHEETS), DESIGN RESOURCES (INCLUDING REFERENCE DESIGNS), APPLICATION OR OTHER DESIGN ADVICE, WEB TOOLS, SAFETY INFORMATION, AND OTHER RESOURCES "AS IS" AND WITH ALL FAULTS, AND DISCLAIMS ALL WARRANTIES, EXPRESS AND IMPLIED, INCLUDING WITHOUT LIMITATION ANY IMPLIED WARRANTIES OF MERCHANTABILITY, FITNESS FOR A PARTICULAR PURPOSE OR NON-INFRINGEMENT OF THIRD PARTY INTELLECTUAL PROPERTY RIGHTS.

These resources are intended for skilled developers designing with TI products. You are solely responsible for (1) selecting the appropriate TI products for your application, (2) designing, validating and testing your application, and (3) ensuring your application meets applicable standards, and any other safety, security, regulatory or other requirements.

These resources are subject to change without notice. TI grants you permission to use these resources only for development of an application that uses the TI products described in the resource. Other reproduction and display of these resources is prohibited. No license is granted to any other TI intellectual property right or to any third party intellectual property right. TI disclaims responsibility for, and you will fully indemnify TI and its representatives against, any claims, damages, costs, losses, and liabilities arising out of your use of these resources.

TI's products are provided subject to [TI's Terms of Sale](#) or other applicable terms available either on ti.com or provided in conjunction with such TI products. TI's provision of these resources does not expand or otherwise alter TI's applicable warranties or warranty disclaimers for TI products.

TI objects to and rejects any additional or different terms you may have proposed.

Mailing Address: Texas Instruments, Post Office Box 655303, Dallas, Texas 75265
Copyright © 2022, Texas Instruments Incorporated

Looking for pricing, stock, or lifecycle information?

Click below to explore more details on WIN SOURCE:

 [View TL441CNSR on WIN SOURCE](#)

 [Texas Instruments](#) Information

Optimize Your Supply Chain with WIN SOURCE Solutions

-  Global Sourcing Solution
-  Obsolete Management
-  Cost Control Management
-  Shortage Management
-  Alternative Solution
-  Excess Inventory Management