



THE DATASHEET OF TL432BIDBZR



ATL431, ATL432 2.5-V Low Iq Adjustable Precision Shunt Regulator

1 Features

- Adjustable Regulated Output of 2.5 V to 36 V
- Very-Low Operating Current
 - $I_{KA(min)} = 35 \mu\text{A}$ (Max)
 - $I_{REF} = 150 \text{ nA}$ (Max)
- Internally Compensated for Stability
 - Stable With No Capacitive Load
- Reference Voltage Tolerances at 25°C
 - 0.5% for B Grade
 - 1% for A Grade
- Typical Temperature Drift
 - 5 mV (–40°C to +85°C); I Version
 - 6 mV (–40°C to +125°C); Q Version
- Extended Cathode Current Range
35 μA to 100 mA
- Low Output Impedance of 0.3 Ω (Max)

2 Applications

- Secondary Side Regulation in Flyback SMPSs
- Industrial, Computing, Consumer, and Portables
- Adjustable Voltage and Current Referencing
- Power Management
- Power Isolation
- Zener Replacement

3 Description

The ATL431 and ATL432 are three-terminal adjustable shunt regulators, with specified thermal stability over applicable automotive, commercial, and industrial temperature ranges. The output voltage can be set to any value between V_{ref} (approximately 2.5 V) and 36 V, with two external resistors. These devices have a typical output impedance of 0.05 Ω . Active output circuitry provides a very sharp turn-on characteristic, making these devices excellent replacements for Zener diodes in many applications, such as onboard regulation, adjustable power supplies, and switching power supplies.

The ATL43x has > 20x improvement cathode current range over its TL43x predecessor. It also is stable with a wider range of load capacitance types and values.

ATL431 and ATL432 are the exact same parts but with different pinouts and order numbers. The ATL43x is offered in two grades, with initial tolerances (at 25°C) of 0.5%, 1%, for the B and A grade, respectively. In addition, low output drift vs temperature ensures consistent voltage regulation over the entire temperature range.

The ATL43xxI devices are characterized for operation from –40°C to +85°C, and the ATL43xxQ devices are characterized for operation from –40°C to +125°C.

Device Information⁽¹⁾

PART NUMBER	PACKAGE	BODY SIZE (NOM)
ATL431 ATL432	SOT (3)	2.90 mm x 1.60 mm

(1) For all available packages, see the orderable addendum at the end of the data sheet.

Simplified Schematic

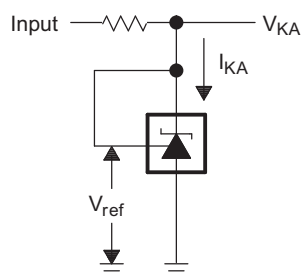

Stability Region for $V_{KA} = 15.0 \text{ V}$

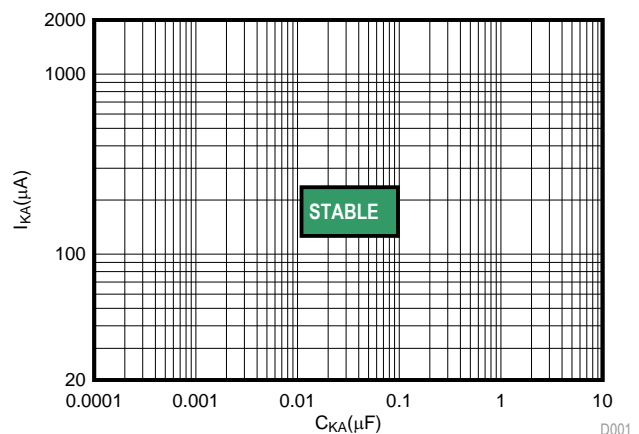

D001



Table of Contents

1 Features	1	8.3 Feature Description	11
2 Applications	1	8.4 Device Functional Modes	12
3 Description	1	9 Application and Implementation	13
4 Revision History	2	9.1 Application Information	13
5 Pin Configuration and Functions	3	9.2 Typical Applications	14
6 Specifications	3	10 Power Supply Recommendations	18
6.1 Absolute Maximum Ratings	3	11 Layout	18
6.2 ESD Ratings	3	11.1 Layout Guidelines	18
6.3 Recommended Operating Conditions	3	11.2 Layout Example	18
6.4 Thermal Information	4	12 Device and Documentation Support	19
6.5 Electrical Characteristics, ATL431Ax, ATL432Ax	4	12.1 Related Links	19
6.6 Electrical Characteristics, ATL431Bx, ATL432Bx	4	12.2 Receiving Notification of Documentation Updates	19
6.7 Typical Characteristics	5	12.3 Community Resources	19
7 Parameter Measurement Information	9	12.4 Trademarks	19
8 Detailed Description	11	12.5 Electrostatic Discharge Caution	19
8.1 Overview	11	12.6 Glossary	19
8.2 Functional Block Diagram	11	13 Mechanical, Packaging, and Orderable Information	19

4 Revision History

NOTE: Page numbers for previous revisions may differ from page numbers in the current version.

Changes from Revision C (September 2015) to Revision D	Page
• Changed <i>Small-Signal Voltage Amplification vs Frequency</i> with an updated graph to provide additional data	6
• Changed <i>Test Circuit for Phase and Gain Measurement</i> with an updated schematic	9
• Updated Comparator Mode specifications in <i>Design Parameters</i>	14
• Added <i>Receiving Notification of Documentation Updates</i> section	19

Changes from Revision B (May 2015) to Revision C	Page
• Changed ATL432xx status from PREVIEW to PRODUCTION	1

Changes from Revision A (April 2015) to Revision B	Page
• Changed ATL431AQ, ATL431BI and ATL431BQ status from PREVIEW to PRODUCTION	1
• Changed flyback schematic to represent a more robust design	13
• Added flyback supply reliability recommendation	18

Changes from Original (March 2013) to Revision A	Page
• Initial release of full version	1

5 Pin Configuration and Functions

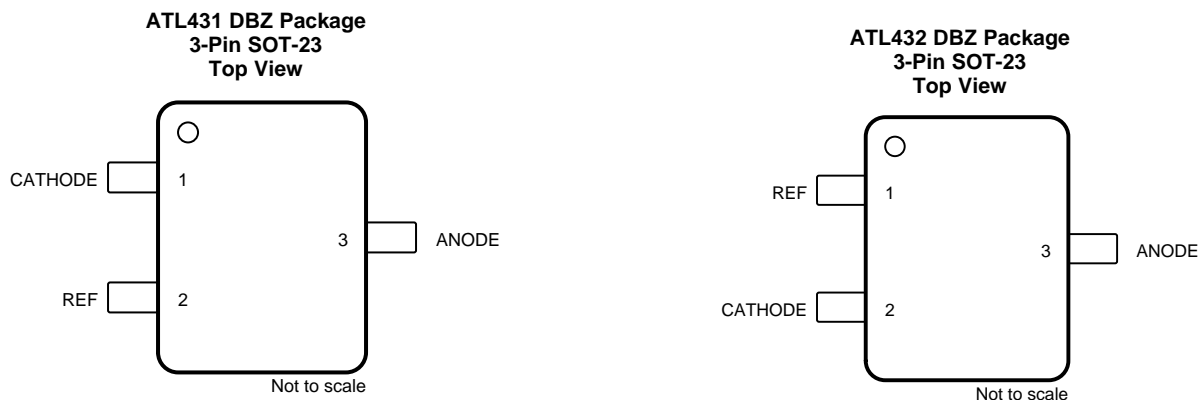

Pin Functions

NAME	PIN NO.		I/O	DESCRIPTION
	ATL431x	ATL432x		
CATHODE	1	2	I/O	Shunt Current/Voltage input
REF	2	1	I	Threshold relative to common anode
ANODE	3	3	O	Common pin, normally connected to ground

6 Specifications

6.1 Absolute Maximum Ratings⁽¹⁾

over operating free-air temperature range (unless otherwise noted)

		MIN	MAX	UNIT
V_{KA}	Cathode voltage ⁽²⁾		40	V
I_{KA}	Continuous cathode current	-100	150	mA
$I_{I(ref)}$	Reference input current	-0.05	10	mA
T_J	Operating virtual junction temperature	-40	150	°C
T_{stg}	Storage temperature	-65	150	°C

- (1) Stresses beyond those listed under *Absolute Maximum Ratings* may cause permanent damage to the device. These are stress ratings only, and functional operation of the device at these or any other conditions beyond those indicated under *Recommended Operating Conditions* is not implied. Exposure to absolute-maximum-rated conditions for extended periods may affect device reliability.
- (2) All voltage values are with respect to ANODE, unless otherwise noted.

6.2 ESD Ratings

		VALUE	UNIT
$V_{(ESD)}$	Electrostatic discharge	Human-body model (HBM), per ANSI/ESDA/JEDEC JS-001 ⁽¹⁾	±2000
		Charged-device model (CDM), per JEDEC specification JESD22-C101 ⁽²⁾	±1000

- (1) JEDEC document JEP155 states that 500-V HBM allows safe manufacturing with a standard ESD control process.
- (2) JEDEC document JEP157 states that 250-V CDM allows safe manufacturing with a standard ESD control process.

6.3 Recommended Operating Conditions

		MIN	MAX	UNIT
V_{KA}	Cathode voltage	V_{ref}	36	V
I_{KA}	Cathode current	.035	100	mA
T_A	Operating free-air temperature	"I" Grade	-40	85
		"Q" Grade	-40	125

6.4 Thermal Information

THERMAL METRIC ⁽¹⁾		ATL43xx	
		DBZ (SOT-23)	
		3 PINS	
			UNIT
$R_{\theta JA}$	Junction-to-ambient thermal resistance	331.8	°C/W
$R_{\theta JC(top)}$	Junction-to-case (top) thermal resistance	106.5	°C/W
$R_{\theta JB}$	Junction-to-board thermal resistance	64.6	°C/W
Ψ_{JT}	Junction-to-top characterization parameter	4.9	°C/W
Ψ_{JB}	Junction-to-board characterization parameter	62.9	°C/W

(1) For more information about traditional and new thermal metrics, see the [Semiconductor and IC Package Thermal Metrics](#) application report.

6.5 Electrical Characteristics, ATL431Ax, ATL432Ax

over recommended operating conditions, $T_A = 25^\circ\text{C}$ (unless otherwise noted)

PARAMETER	TEST CIRCUIT	TEST CONDITIONS	MIN	TYP	MAX	UNIT
V_{ref}	Figure 22	$V_{KA} = V_{ref}$, $I_{KA} = 1\text{ mA}$	2475	2500	2525	mV
$V_{I(dev)}$	Figure 22	$V_{KA} = V_{ref}$, $I_{KA} = 1\text{ mA}$		5	15	mV
		ATL43xAI; $T_A = -40^\circ\text{C}$ to 85°C ATL43xAQ; $T_A = -40^\circ\text{C}$ to 125°C		6	34	
$\Delta V_{ref} / \Delta V_{KA}$	Figure 23	$I_{KA} = 1\text{ mA}$		-0.4	-2.7	mV/V
		$\Delta V_{KA} = 10\text{ V} - V_{ref}$ $\Delta V_{KA} = 36\text{ V} - 10\text{ V}$		-0.1	-2	
I_{ref}	Figure 23	$I_{KA} = 1\text{ mA}$, $R_1 = 10\text{ k}\Omega$, $R_2 = \infty$		30	150	nA
$I_{I(dev)}$	Figure 23	$I_{KA} = 1\text{ mA}$, $R_1 = 10\text{ k}\Omega$, $R_2 = \infty$		20	50	nA
I_{min}	Figure 22 Figure 5	$V_{KA} = V_{ref}$		20	35	μA
I_{off}	Figure 24	$V_{KA} = 36\text{ V}$, $V_{ref} = 0$		0.05	0.2	μA
$ z_{KA} $	Figure 22	$V_{KA} = V_{ref}$, $f \leq 1\text{ kHz}$, $I_{KA} = 1\text{ mA}$ to 100 mA		0.05	0.3	Ω

6.6 Electrical Characteristics, ATL431Bx, ATL432Bx

over recommended operating conditions, $T_A = 25^\circ\text{C}$ (unless otherwise noted)

PARAMETER	TEST CIRCUIT	TEST CONDITIONS	MIN	TYP	MAX	UNIT
V_{ref}	Figure 22	$V_{KA} = V_{ref}$, $I_{KA} = 1\text{ mA}$	2487	2500	2512	mV
$V_{I(dev)}$	Figure 22	$V_{KA} = V_{ref}$, $I_{KA} = 1\text{ mA}$		5	15	mV
		ATL43xBI; $T_A = -40^\circ\text{C}$ to 85°C ATL43xBQ; $T_A = -40^\circ\text{C}$ to 125°C		6	34	
$\Delta V_{ref} / \Delta V_{KA}$	Figure 23	$I_{KA} = 1\text{ mA}$		-0.4	-2.7	mV/V
		$\Delta V_{KA} = 10\text{ V} - V_{ref}$ $\Delta V_{KA} = 36\text{ V} - 10\text{ V}$		-0.1	-2	
I_{ref}	Figure 23	$I_{KA} = 1\text{ mA}$, $R_1 = 10\text{ k}\Omega$, $R_2 = \infty$		30	150	nA
$I_{I(dev)}$	Figure 23	$I_{KA} = 1\text{ mA}$, $R_1 = 10\text{ k}\Omega$, $R_2 = \infty$		20	50	nA
I_{min}	Figure 22 Figure 5	$V_{KA} = V_{ref}$		20	35	μA
I_{off}	Figure 24	$V_{KA} = 36\text{ V}$, $V_{ref} = 0$		0.05	0.2	μA
$ z_{KA} $	Figure 22	$V_{KA} = V_{ref}$, $f \leq 1\text{ kHz}$, $I_{KA} = 1\text{ mA}$ to 100 mA		0.05	0.3	Ω

6.7 Typical Characteristics

Data at high and low temperatures are applicable only within the recommended operating free-air temperature ranges of the various devices.

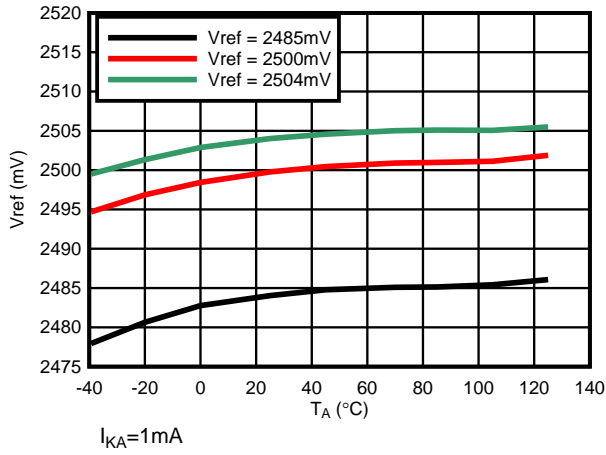

Figure 1. Reference Voltage vs Free-Air Temperature

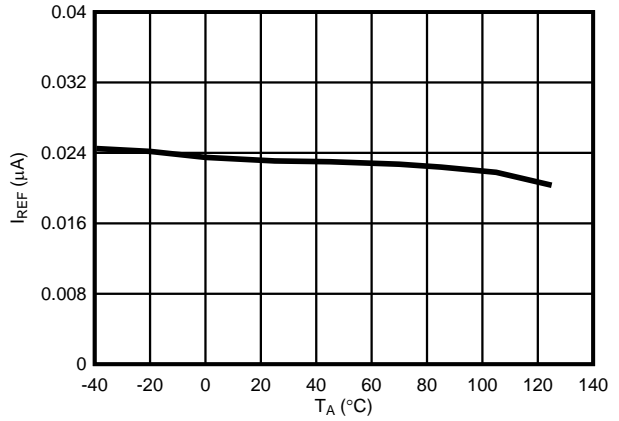

Figure 2. Reference Current vs Free-Air Temperature

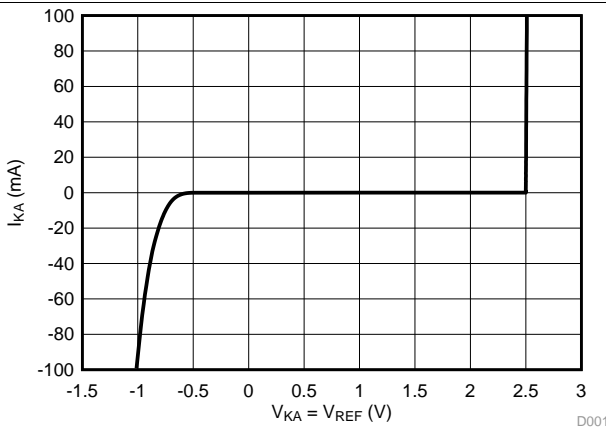

Figure 3. Cathode Current vs Cathode Voltage

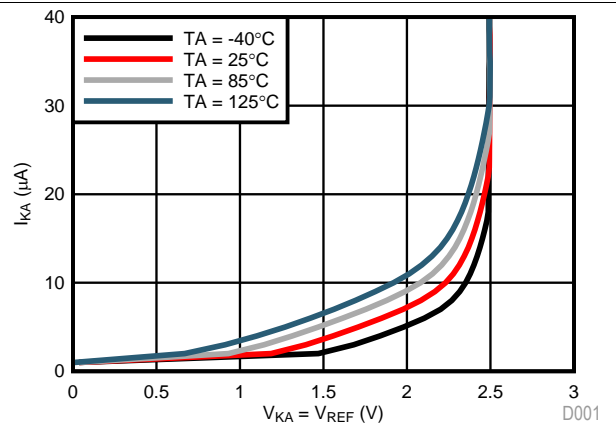

Figure 4. Cathode Current vs Cathode Voltage

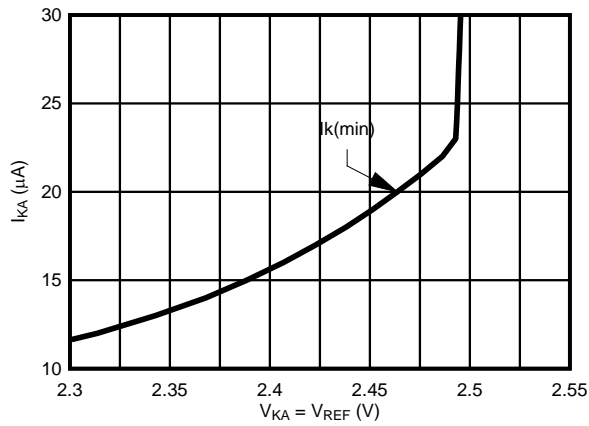

Figure 5. Cathode Current vs Cathode Voltage

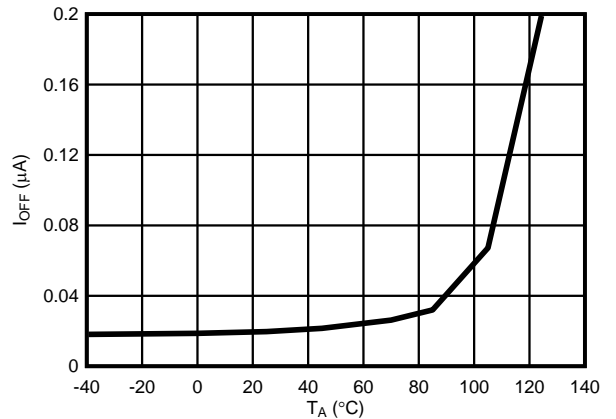

Figure 6. Off-State Cathode Current vs Free-Air Temperature

Typical Characteristics (continued)

Data at high and low temperatures are applicable only within the recommended operating free-air temperature ranges of the various devices.

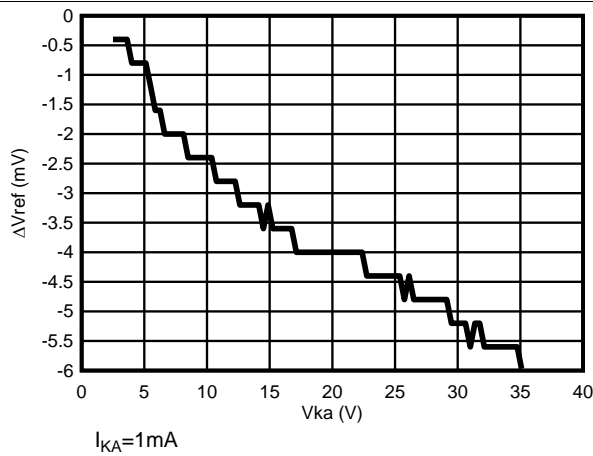

Figure 7. Delta Reference Voltage vs Cathode Voltage

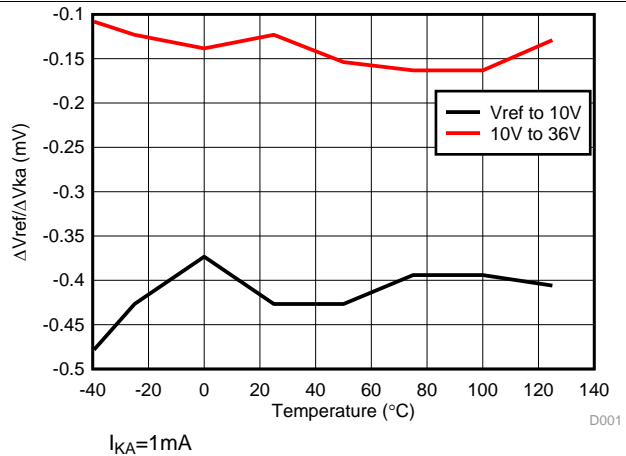

Figure 8. Delta Reference Voltage vs Cathode Voltage

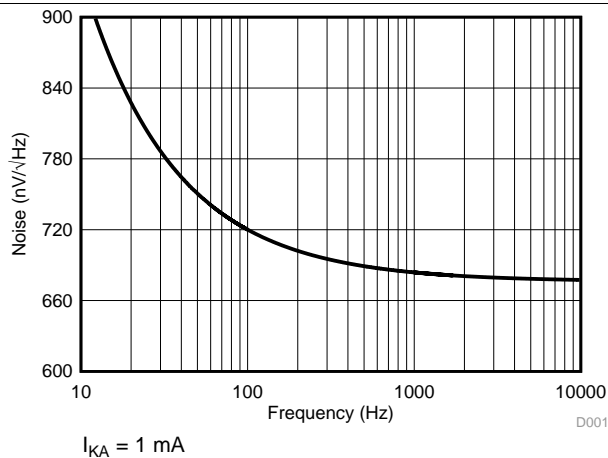

Figure 9. Noise Voltage

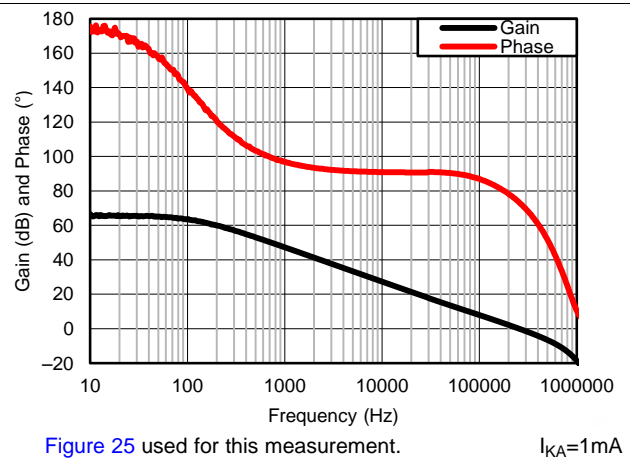

Figure 25 used for this measurement.

Figure 10. Small-Signal Voltage Amplification vs Frequency

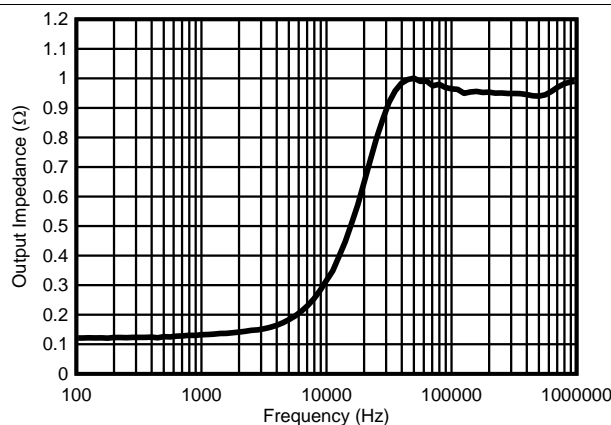

Figure 26 used for this measurement.

Figure 11. Output Impedance vs Frequency

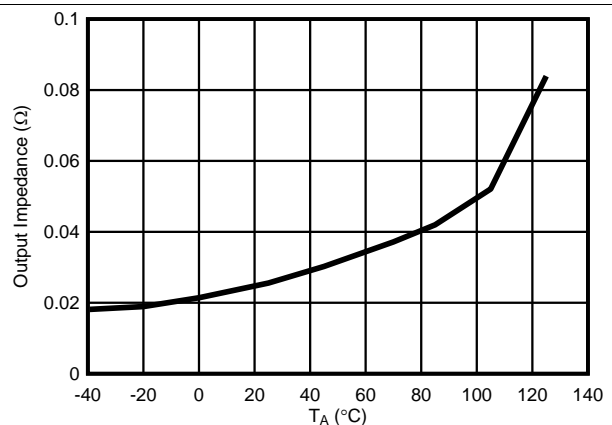

Figure 26 used for this measurement.

Figure 12. DC Output Impedance vs Temperature

Typical Characteristics (continued)

Data at high and low temperatures are applicable only within the recommended operating free-air temperature ranges of the various devices.

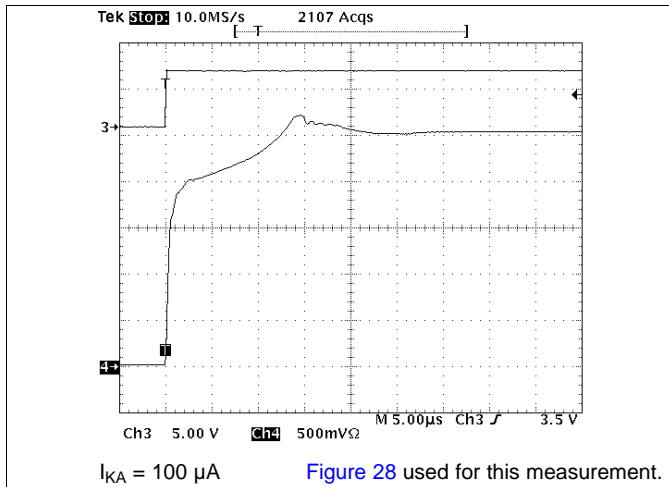

Figure 13. Pulse Response

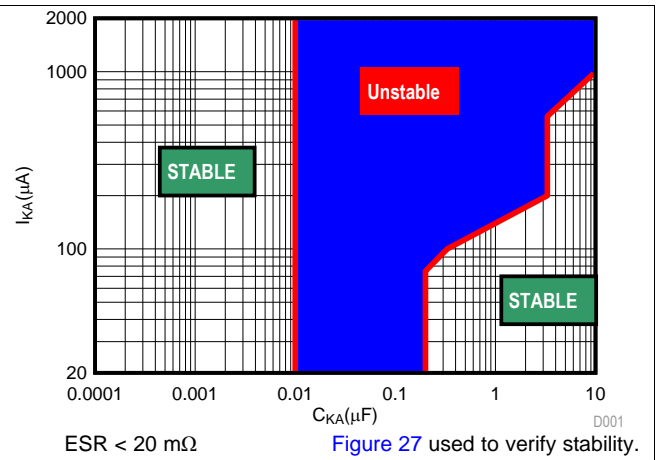

Figure 14. Low I_{KA} ($V_{KA} = 2.5$ V) Stability Boundary Conditions all ATL43xx Devices

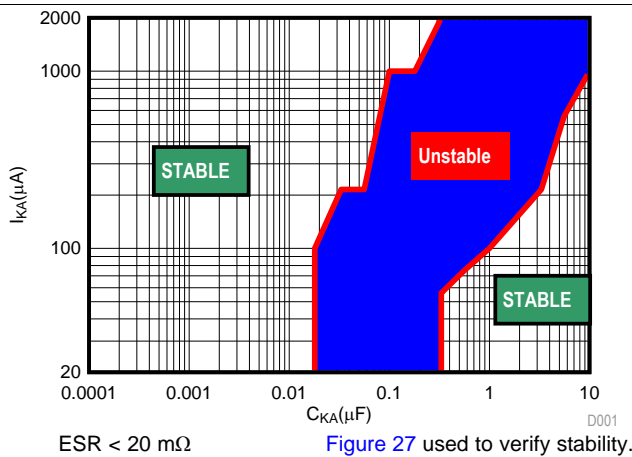

Figure 15. Low I_{KA} ($V_{KA} = 5.0$ V) Stability Boundary Conditions all ATL43xx Devices

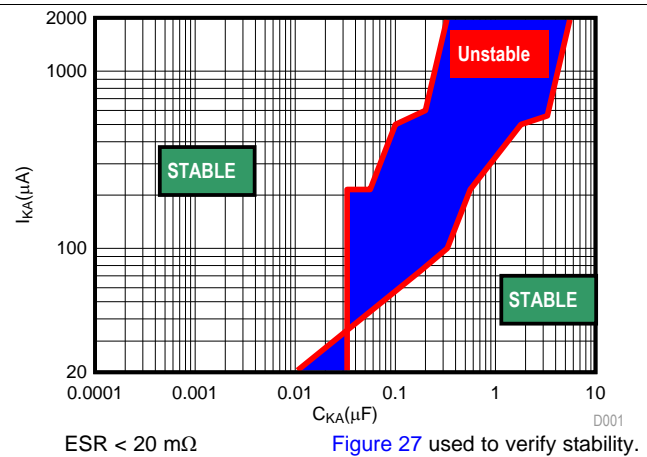

Figure 16. Low I_{KA} ($V_{KA} = 10.0$ V) Stability Boundary Conditions all ATL43xx Devices

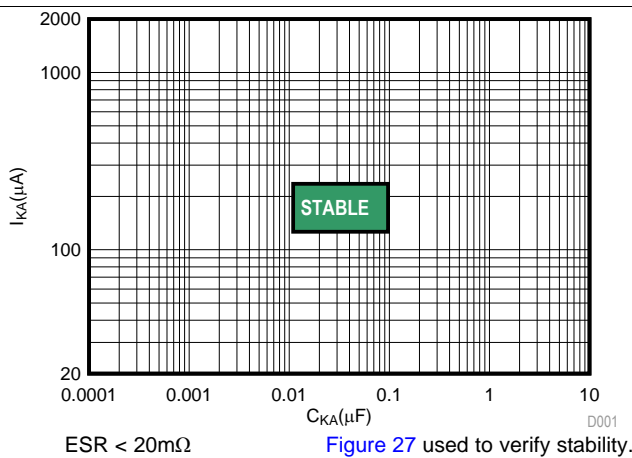

Figure 17. Low I_{KA} ($V_{KA} = 15.0$ V) Stability Boundary Conditions all ATL43xx Devices

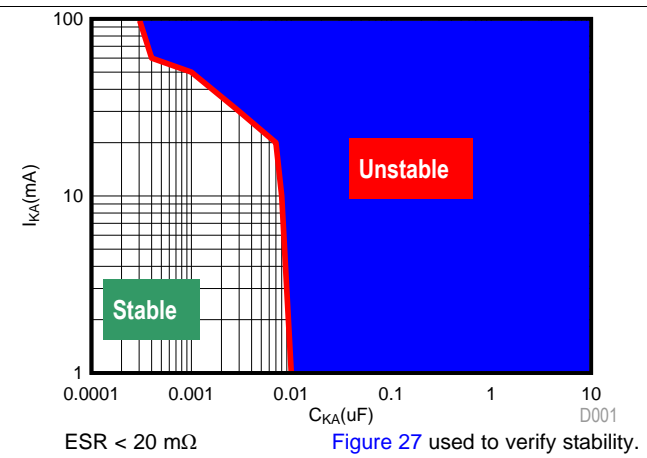
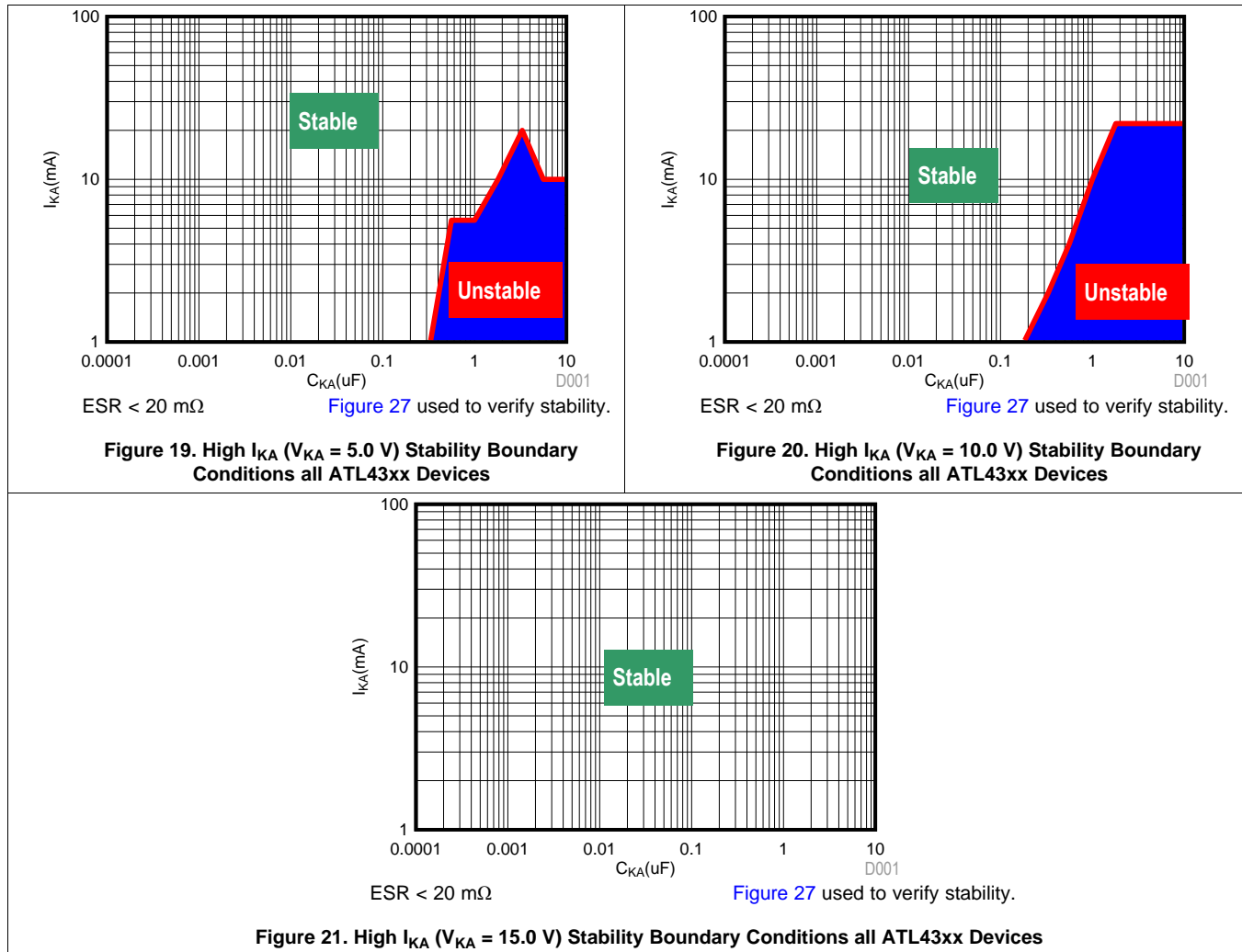

Figure 18. High I_{KA} ($V_{KA} = 2.5$ V) Stability Boundary Conditions all ATL43xx Devices

Typical Characteristics (continued)

Data at high and low temperatures are applicable only within the recommended operating free-air temperature ranges of the various devices.



7 Parameter Measurement Information

The deviation parameters $V_{ref(dev)}$ and $I_{ref(dev)}$ are defined as the differences between the maximum and minimum values obtained over the rated temperature range. The average full-range temperature coefficient of the reference input voltage α_{Vref} is defined as:

$$|\alpha_{Vref}| \left(\frac{ppm}{^{\circ}C} \right) = \frac{\left(\frac{V_{I(dev)}}{V_{ref \text{ at } 25^{\circ}C}} \right) \times 10^6}{\Delta T_A}$$

where:

ΔT_A is the rated operating temperature range of the device.

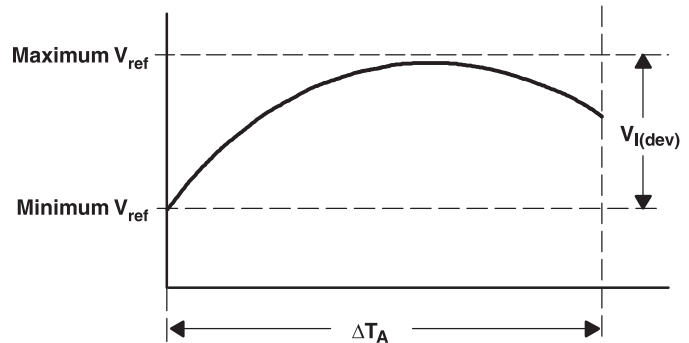

α_{Vref} is positive or negative, depending on whether minimum V_{ref} or maximum V_{ref} , respectively, occurs at the lower temperature.

The dynamic impedance is defined as: $|z_{KA}| = \frac{\Delta V_{KA}}{\Delta I_{KA}}$

When the device is operating with two external resistors (see Figure 23), the total dynamic impedance of the circuit is given by: $|z'| = \frac{\Delta V}{\Delta I}$ which is approximately equal to $|z_{KA}| \left(1 + \frac{R1}{R2} \right)$

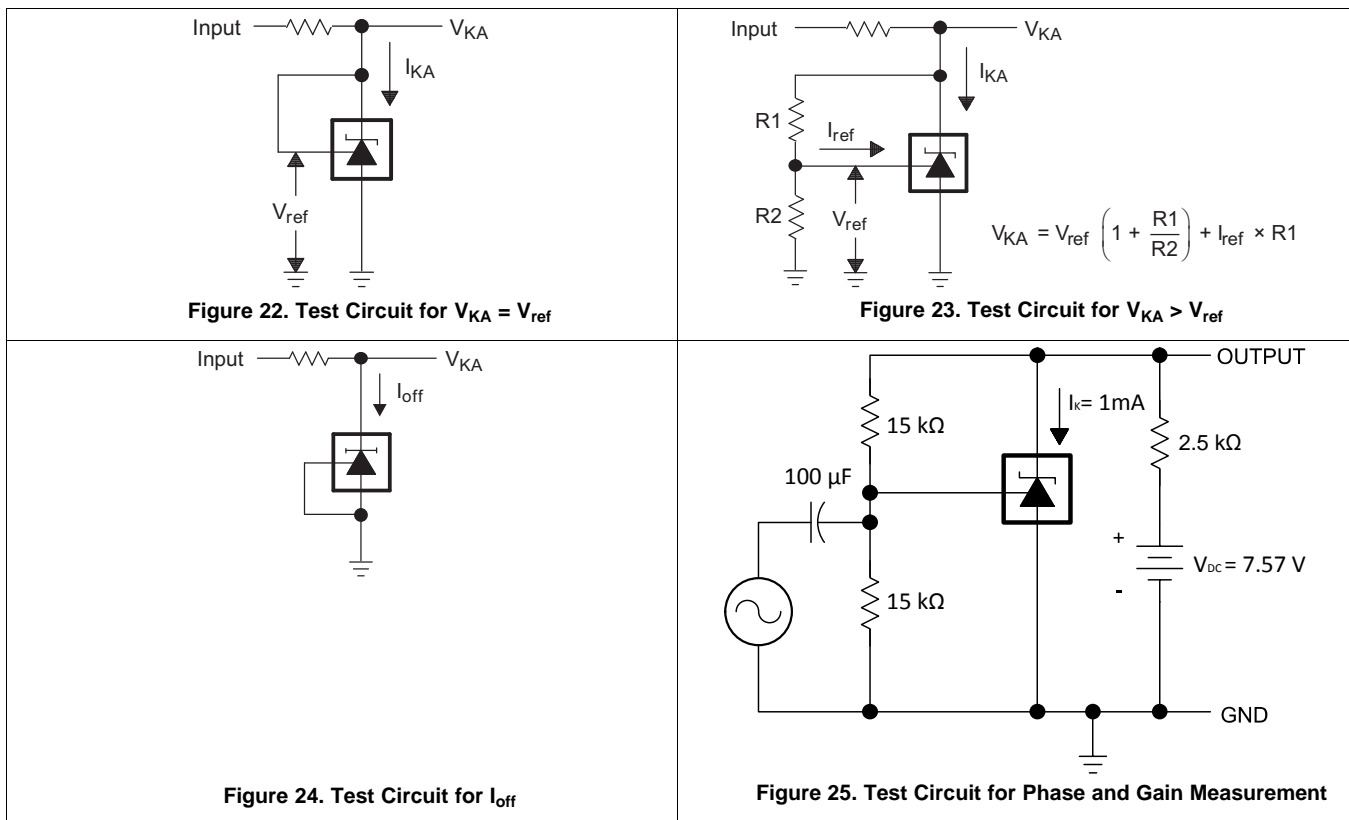

Parameter Measurement Information (continued)

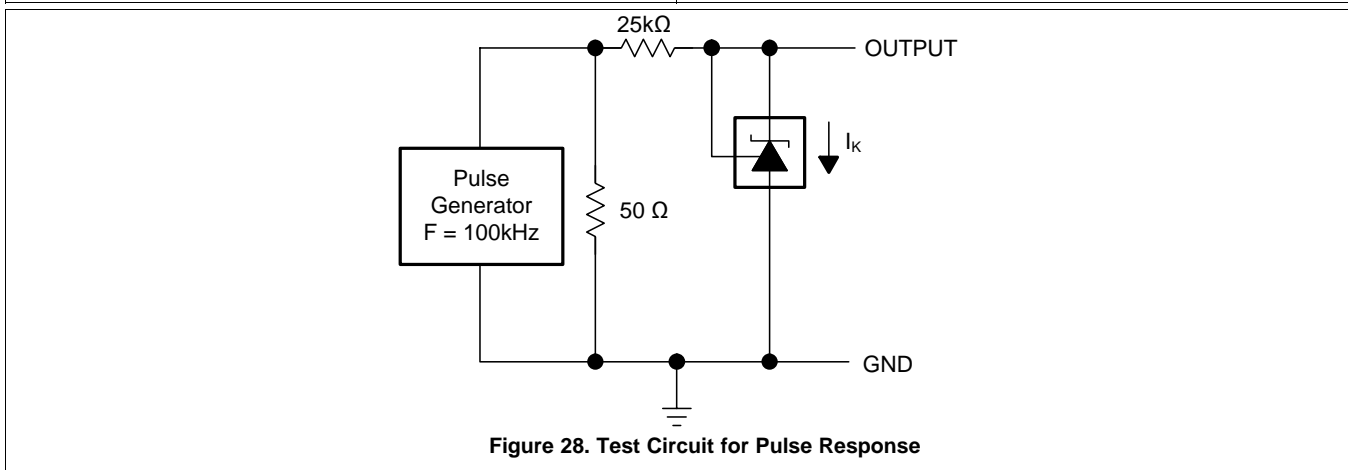
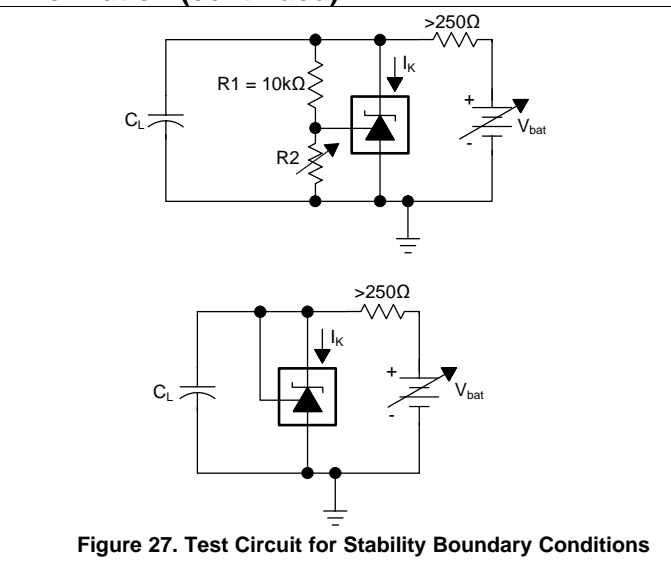
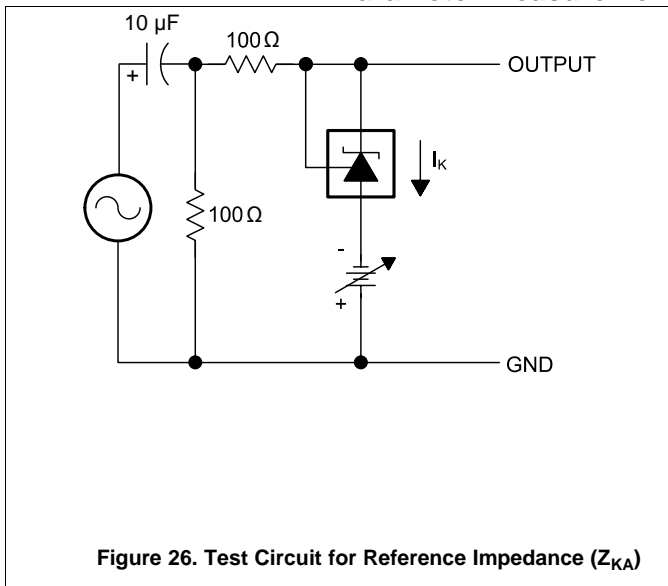

8 Detailed Description

8.1 Overview

ATL43x is a low power counterpart to TL431 and TLV431, having lower minimum cathode current ($I_{k(\min)} = 35 \mu\text{A}$). Like TL431, ATL43x is used in conjunction with its key components to behave as a single voltage reference, error amplifier, voltage clamp or comparator with integrated reference.

ATL43x can be operated and adjusted to cathode voltages from 2.5 V to 36 V, making this part optimum for a wide range of end equipments in industrial, auto, telecom and computing. In order for this device to behave as a shunt regulator or error amplifier, $> 35 \mu\text{A}$ ($I_{\min(\max)}$) must be supplied in to the cathode pin. Under this condition, feedback can be applied from the Cathode and Ref pins to create a replica of the internal reference voltage.

Various reference voltage options can be purchased with initial tolerances (at 25°C) of 0.5% and 1.0%. These reference options are denoted by B (0.5%) and A (1.0%) after the ATL43x.

The ATL43xxI devices are characterized for operation from -40°C to $+85^\circ\text{C}$, and the ATL43xxQ devices are characterized for operation from -40°C to $+125^\circ\text{C}$.

8.2 Functional Block Diagram

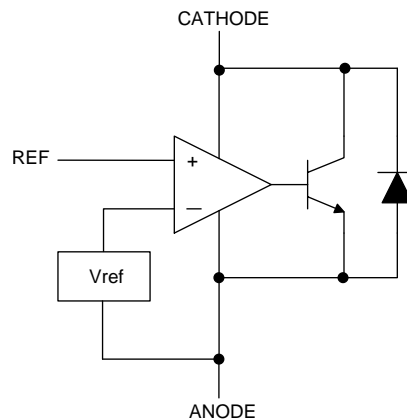

8.3 Feature Description

ATL43x consists of an internal reference and amplifier that outputs a sink current based on the difference between the reference pin and the virtual internal pin. The sink current is produced by an internal Darlington pair.

When operated with enough voltage headroom ($\geq 2.5 \text{ V}$) and cathode current (I_{kA}), ATL43x forces the reference pin to 2.5 V. However, the reference pin can not be left floating, as it needs $I_{\text{ref}} \geq 0.1 \mu\text{A}$ (please see the [Functional Block Diagram](#)). This is because the reference pin is driven into an NPN, which needs base current in order to operate properly.

When feedback is applied from the Cathode and Reference pins, ATL43x behaves as a Zener diode, regulating to a constant voltage dependent on current being supplied into the cathode. This is due to the internal amplifier and reference entering the proper operating regions. The same amount of current needed in the above feedback situation must be applied to this device in open loop, servo or error amplifying implementations in order for it to be in the proper linear region giving ATL43x enough gain.

Unlike many linear regulators, ATL43x is internally compensated to be stable without an output capacitor between the cathode and anode; however, if it is desired to use an output capacitor [Figure 14](#) through [Figure 21](#) can be used as a guide to assist in choosing the correct capacitor to maintain stability.

8.4 Device Functional Modes

8.4.1 Open Loop (Comparator)

When the cathode/output voltage or current of ATL43x is not being fed back to the reference/input pin in any form, this device is operating in open loop. With such high gain in this configuration, ATL43x is typically used as a comparator. Due to the integrated reference, the ATL43x allows users to monitor a certain level of a single signal.

8.4.2 Closed Loop

When the cathode/output voltage or current of ATL43x is being fed back to the reference/input pin in any form, this device is operating in closed loop. The majority of applications involving ATL43x use it in this manner to regulate a fixed voltage or current. The feedback enables this device to behave as an error amplifier, computing a portion of the output voltage and adjusting it to maintain the desired regulation. This is done by relating the output voltage back to the reference pin in a manner to make it equal to the internal reference voltage, which can be accomplished via resistive or direct feedback.

9 Application and Implementation

NOTE

Information in the following applications sections is not part of the TI component specification, and TI does not warrant its accuracy or completeness. TI's customers are responsible for determining suitability of components for their purposes. Customers should validate and test their design implementation to confirm system functionality.

9.1 Application Information

Figure 29 shows the ATL43x used in a 24-V isolated flyback supply. The output of the regulator, plus the forward voltage drop of the optocoupler LED ($2.5 + 0.7 = 3.2$ V), determine the minimum voltage that can be regulated in an isolated supply configuration. Regulated voltage as low as 5.0 Vdc is possible in the topology shown in Figure 29.

The 431 family of devices are prevalent in these applications, being designers go-to choice for secondary side regulation. Due to this prevalence, this section will further go on to explain operation and design in both states of ATL43x that this application will see, open loop (Comparator + V_{ref}) and closed loop (Shunt Regulator).

ATL43x's key benefit in isolated supplies is the no load power savings gained by the $> 20x$ decrease in I_{Kmin} from TL431. More information about this and other benefits can be found in [Designing with the "Advanced" TL431, ATL431](#), SLVA685. Further information about system stability and using a ATL43x device for compensation can be found in [Compensation Design With TL431 for UCC28600](#), SLUA671.

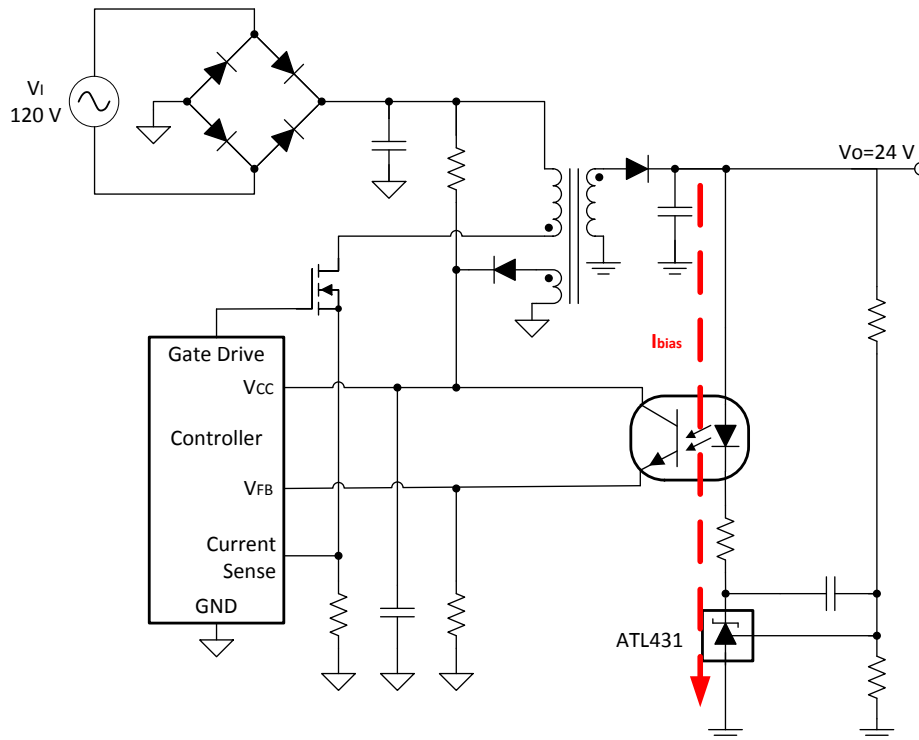

Figure 29. Flyback With Isolation Using ATL43x as Voltage Reference and Error Amplifier

9.2 Typical Applications

9.2.1 Comparator With Integrated Reference (Open Loop)

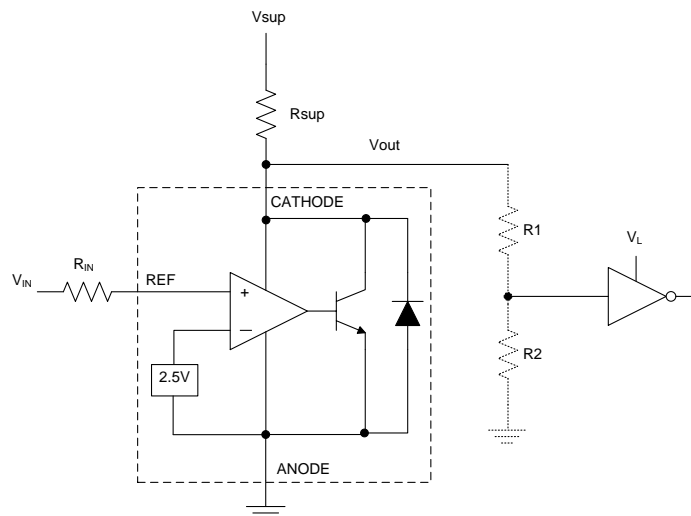

Figure 30. Comparator Application Schematic

9.2.1.1 Design Requirements

For this design example, use the parameters listed in [Table 1](#) as the input parameters.

Table 1. Design Parameters

DESIGN PARAMETER	EXAMPLE VALUE
Input voltage range	0 V to 3.3 V
Input resistance	100 k Ω
Supply voltage	5 V
Cathode current (I_k)	50 μ A
High output voltage level ($V_{in} < 2.5$ V)	V_{sup}
Low output voltage level ($V_{in} > 2.5$ V)	~ 2 V

9.2.1.2 Detailed Design Procedure

When using ATL43x as a comparator with reference, determine the following:

- Input voltage range
- Reference voltage accuracy
- Output logic input high and low level thresholds
- Current source resistance

9.2.1.2.1 Basic Operation

In the configuration shown in [Figure 30](#) ATL43x will behave as a comparator, comparing the V_{ref} pin voltage to the internal virtual reference voltage. When provided a proper cathode current (I_k), ATL43x will have enough open loop gain to provide a quick response. With the ATL43x's max operating current (I_{min}) being 35 μ A and up to 40 μ A over temperature, operation below that could result in low gain, leading to a slow response.

9.2.1.2.2 Overdrive

Slow or inaccurate responses can also occur when the reference pin is not provided enough overdrive voltage. This is the amount of voltage that is higher than the internal virtual reference. The internal virtual reference voltage will be within the range of 2.5 V ±(0.5% or 1.0%) depending on which version is being used.

The more overdrive voltage provided, the faster the ATL43x will respond.

For applications where ATL43x is being used as a comparator, it is best to set the trip point to greater than the positive expected error (that is, +1.0% for the A version). For fast response, setting the trip point to > 10% of the internal V_{ref} should suffice. Figure 31 shows the transition from V_{OH} to V_{OL} based on the input voltage and can be used as a guide for selecting the overdrive voltage.

For minimal voltage drop or difference from Vin to the ref pin, it is recommended to use an input resistor < 1 MΩ to provide I_{ref}.

9.2.1.2.3 Output Voltage and Logic Input Level

In order for ATL43x to properly be used as a comparator, the logic output must be readable by the receiving logic device. This is accomplished by knowing the input high and low level threshold voltage levels, typically denoted by V_{IH} and V_{IL}.

As seen in Figure 31, ATL43x's output low level voltage in open-loop/comparator mode is ~2 V, which is sufficient for some ≥ 5.0 V supplied logic. However, would not work for 3.3 V and 1.8 V supplied logic. In order to accommodate this, a resistive divider can be tied to the output to attenuate the output voltage to a voltage legible to the receiving low voltage logic device.

ATL43x's output high voltage is approximately V_{sup} due to ATL43x being open-collector. If V_{sup} is much higher than the receiving logic's maximum input voltage tolerance, the output must be attenuated to accommodate the outgoing logic's reliability.

When using a resistive divider on the output, be sure to make the sum of the resistive divider (R1 and R2 in Figure 30) is much greater than R_{sup} in order to not interfere with ATL43x's ability to pull close to V_{sup} when turning off.

9.2.1.2.3.1 Input Resistance

ATL43x requires an input resistance in this application in order to source the reference current (I_{ref}) needed from this device to be in the proper operating regions while turning on. The actual voltage seen at the ref pin will be:

$$V_{ref} = V_{in} - I_{ref} \times R_{in} \tag{1}$$

Because I_{ref} can be as high as 0.15 μA, TI recommends to use a resistance small enough that will mitigate the error that I_{ref} creates from V_{in}. Also, the input resistance must be set high enough as to not surpass the absolute maximum of 10 mA.

9.2.1.3 Application Curve

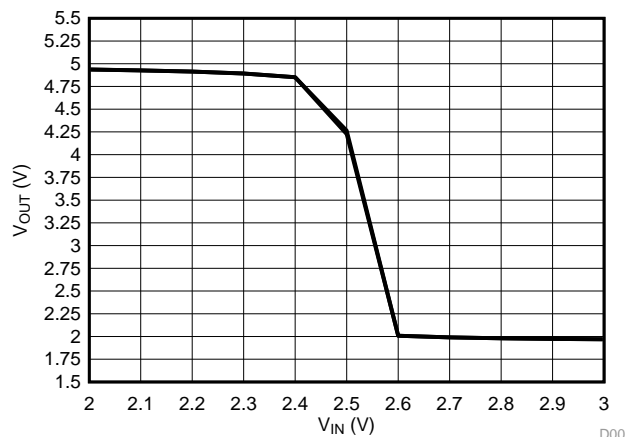

R_{IN} = 100 kΩ V_{SUP} = 5.0 V R_{SUP} = 10 kΩ

Figure 31. Open Loop (Comparator Mode) V_{OUT} vs V_{IN}

9.2.2 Shunt Regulator/Reference

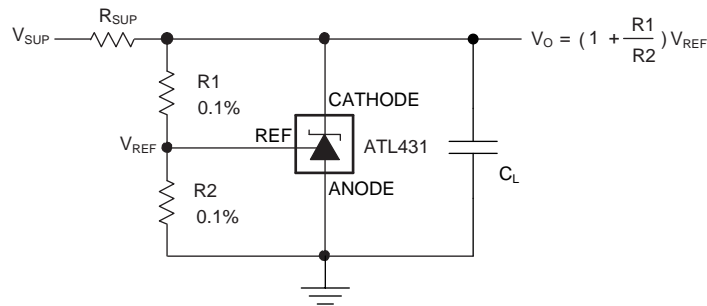

Figure 32. Shunt Regulator Schematic

9.2.2.1 Design Requirements

For this design example, use the parameters listed in [Table 2](#) as the input parameters.

Table 2. Design Parameters

DESIGN PARAMETER	EXAMPLE VALUE
Reference initial accuracy	1.0%
Supply voltage	48 V
Cathode current (I_K)	50 μ A
Output voltage level	2.5 V to 36 V
Load capacitance	1 nF
Feedback resistor values (R1 and R2)	10 k Ω

9.2.2.2 Detailed Design Procedure

When using ATL43x as a Shunt Regulator, determine the following:

- Input voltage range
- Temperature range
- Total accuracy
- Cathode current
- Reference initial accuracy
- Output capacitance

9.2.2.2.1 Programming Output/Cathode Voltage

In order to program the cathode voltage to a regulated voltage a resistive bridge must be shunted between the cathode and anode pins with the mid point tied to the reference pin. This can be seen in [Figure 32](#), with R1 and R2 being the resistive bridge. The cathode/output voltage in the shunt regulator configuration can be approximated by the equation shown in [Figure 32](#). The cathode voltage can be more accurately determined by taking in to account the cathode current:

$$V_O = (1 + R1 / R2) \times V_{ref} - I_{ref} \times R1 \quad (2)$$

For this equation to be valid, ATL43x must be fully biased so that it has enough open loop gain to mitigate any gain error. This can be done by meeting the I_{min} spec denoted in [Electrical Characteristics, ATL431Ax, ATL432Ax](#) table.

9.2.2.2.2 Total Accuracy

When programming the output above unity gain ($V_{KA} = V_{ref}$), ATL43x is susceptible to other errors that may effect the overall accuracy beyond V_{ref} . These errors include:

- R1 and R2 accuracies
- $V_{I(dev)}$ - Change in reference voltage over temperature
- $\Delta V_{ref} / \Delta V_{KA}$ - Change in reference voltage to the change in cathode voltage

- $|z_{KA}|$ - Dynamic impedance, causing a change in cathode voltage with cathode current

Worst case cathode voltage can be determined taking all of the variables in to account. [Setting the Shunt Voltage on an Adjustable Shunt](#), SLVA445, assists designers in setting the shunt voltage to achieve optimum accuracy for this device.

9.2.2.2.3 Stability

Though ATL43x is stable with no capacitive load, the device that receives the shunt regulator's output voltage could present a capacitive load that is within the ATL43x region of stability, shown in [Figure 14](#) through [Figure 21](#). Also, designers may use capacitive loads to improve the transient response or for power supply decoupling.

[Figure 14](#) through [Figure 21](#) should be used as a guide for capacitor selection and compensation. It is characterized using ceramic capacitors with very-low ESR. When it is desirable to use a capacitor within the unstable region, higher ESR capacitors can be used to stabilize ATL43x or an external series resistance can be added. For more information and guidance on ESR values, see [Designing with the "Advanced" TL431, ATL431, SLVA685](#).

Unlike TL431, the stability boundary is characterized and determined with resistors 250 Ω and greater. Which is more suitable for low cathode current applications.

9.2.2.3 Application Curves

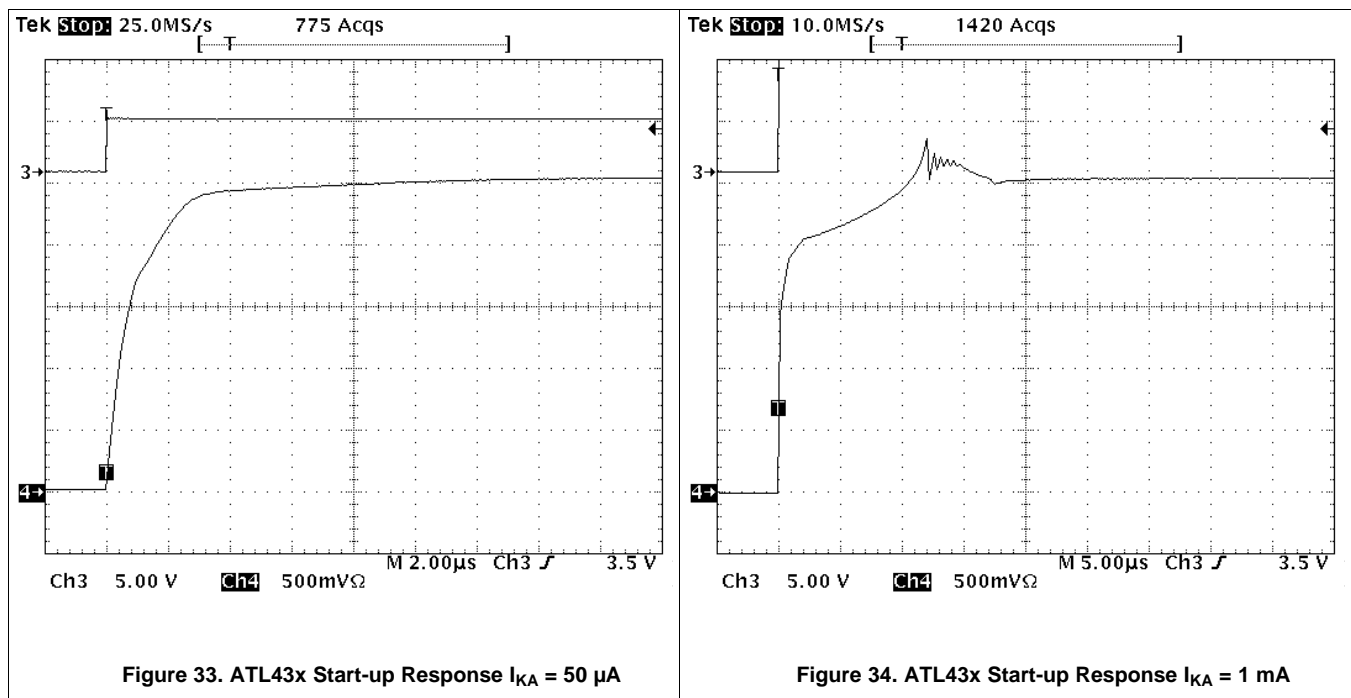

Figure 33. ATL43x Start-up Response $I_{KA} = 50 \mu A$

Figure 34. ATL43x Start-up Response $I_{KA} = 1 mA$

10 Power Supply Recommendations

When using ATL43x in a flyback supply (see [Figure 29](#)) it is often common for designers to place the bias resistor between the Anode of the Opto-Coupler and the output voltage ($V_O = 24\text{ V}$). However, this makes ATL43x more susceptible to EOS/ESD damage. Therefore, TI recommends to place the bias resistor between the Cathodes of the Opto-Coupler and ATL43x, as shown in [Figure 29](#). For further explanation, see [Designing with the "Advanced" TL431, ATL431](#), SLVA685.

When using ATL43x as a Linear Regulator to supply a load, designers will typically use a bypass capacitor on the output/cathode pin. Be sure that the capacitance is within the stability criteria shown in [Figure 14](#) through [Figure 21](#).

To not exceed the maximum cathode current, be sure that the supply voltage is current limited. Also, be sure to limit the current being driven into the Ref pin, as not to exceed it's absolute maximum rating.

For applications shunting high currents, pay attention to the cathode and anode trace lengths, adjusting the width of the traces to have the proper current density.

11 Layout

11.1 Layout Guidelines

Place decoupling capacitors as close to the device as possible. Use appropriate widths for traces when shunting high currents to avoid excessive voltage drops.

11.2 Layout Example

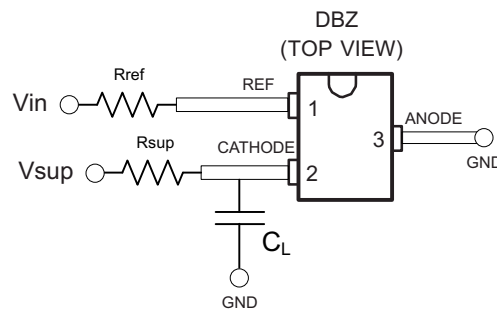

Figure 35. DBZ Layout Example

12 Device and Documentation Support

12.1 Related Links

The table below lists quick access links. Categories include technical documents, support and community resources, tools and software, and quick access to sample or buy.

Table 3. Related Links

PARTS	PRODUCT FOLDER	SAMPLE & BUY	TECHNICAL DOCUMENTS	TOOLS & SOFTWARE	SUPPORT & COMMUNITY
ATL431	Click here	Click here	Click here	Click here	Click here
ATL432	Click here	Click here	Click here	Click here	Click here

12.2 Receiving Notification of Documentation Updates

To receive notification of documentation updates, navigate to the device product folder on ti.com. In the upper right corner, click on *Alert me* to register and receive a weekly digest of any product information that has changed. For change details, review the revision history included in any revised document.

12.3 Community Resources

The following links connect to TI community resources. Linked contents are provided "AS IS" by the respective contributors. They do not constitute TI specifications and do not necessarily reflect TI's views; see TI's [Terms of Use](#).

TI E2E™ Online Community *TI's Engineer-to-Engineer (E2E) Community*. Created to foster collaboration among engineers. At e2e.ti.com, you can ask questions, share knowledge, explore ideas and help solve problems with fellow engineers.

Design Support *TI's Design Support* Quickly find helpful E2E forums along with design support tools and contact information for technical support.

12.4 Trademarks

E2E is a trademark of Texas Instruments.
All other trademarks are the property of their respective owners.

12.5 Electrostatic Discharge Caution



This integrated circuit can be damaged by ESD. Texas Instruments recommends that all integrated circuits be handled with appropriate precautions. Failure to observe proper handling and installation procedures can cause damage.

ESD damage can range from subtle performance degradation to complete device failure. Precision integrated circuits may be more susceptible to damage because very small parametric changes could cause the device not to meet its published specifications.

12.6 Glossary

[SLYZ022](#) — *TI Glossary*.

This glossary lists and explains terms, acronyms, and definitions.

13 Mechanical, Packaging, and Orderable Information

The following pages include mechanical, packaging, and orderable information. This information is the most current data available for the designated devices. This data is subject to change without notice and revision of this document. For browser-based versions of this data sheet, refer to the left-hand navigation.

PACKAGING INFORMATION

Orderable Device	Status (1)	Package Type	Package Drawing	Pins	Package Qty	Eco Plan (2)	Lead/Ball Finish (6)	MSL Peak Temp (3)	Op Temp (°C)	Device Marking (4/5)	Samples
ATL431AIDBZR	ACTIVE	SOT-23	DBZ	3	3000	Green (RoHS & no Sb/Br)	CU NIPDAU CU NIPDAUAG	Level-1-260C-UNLIM	-40 to 85	(ZCKS, ZCR3)	Samples
ATL431AQDBZR	ACTIVE	SOT-23	DBZ	3	3000	Green (RoHS & no Sb/Br)	CU NIPDAU CU NIPDAUAG	Level-1-260C-UNLIM	-40 to 125	(ZCLS, ZCS3)	Samples
ATL431BIDBZR	ACTIVE	SOT-23	DBZ	3	3000	Green (RoHS & no Sb/Br)	CU NIPDAU CU NIPDAUAG	Level-1-260C-UNLIM	-40 to 85	(ZCMS, ZCT3)	Samples
ATL431BQDBZR	ACTIVE	SOT-23	DBZ	3	3000	Green (RoHS & no Sb/Br)	CU NIPDAU CU NIPDAUAG	Level-1-260C-UNLIM	-40 to 125	(ZCJS, ZCU3)	Samples
ATL432AIDBZR	ACTIVE	SOT-23	DBZ	3	3000	Green (RoHS & no Sb/Br)	CU NIPDAU CU NIPDAUAG	Level-1-260C-UNLIM	-40 to 85	(ZCNS, ZCV3)	Samples
ATL432AQDBZR	ACTIVE	SOT-23	DBZ	3	3000	Green (RoHS & no Sb/Br)	CU NIPDAU CU NIPDAUAG	Level-1-260C-UNLIM	-40 to 125	(ZCOS, ZCW3)	Samples
ATL432BIDBZR	ACTIVE	SOT-23	DBZ	3	3000	Green (RoHS & no Sb/Br)	CU NIPDAU CU NIPDAUAG	Level-1-260C-UNLIM	-40 to 85	(ZCPS, ZCX3)	Samples
ATL432BQDBZR	ACTIVE	SOT-23	DBZ	3	3000	Green (RoHS & no Sb/Br)	CU NIPDAU CU NIPDAUAG	Level-1-260C-UNLIM	-40 to 125	(ZCQS, ZCY3)	Samples

(1) The marketing status values are defined as follows:

ACTIVE: Product device recommended for new designs.

LIFEBUY: TI has announced that the device will be discontinued, and a lifetime-buy period is in effect.

NRND: Not recommended for new designs. Device is in production to support existing customers, but TI does not recommend using this part in a new design.

PREVIEW: Device has been announced but is not in production. Samples may or may not be available.

OBSOLETE: TI has discontinued the production of the device.

(2) **RoHS:** TI defines "RoHS" to mean semiconductor products that are compliant with the current EU RoHS requirements for all 10 RoHS substances, including the requirement that RoHS substance do not exceed 0.1% by weight in homogeneous materials. Where designed to be soldered at high temperatures, "RoHS" products are suitable for use in specified lead-free processes. TI may reference these types of products as "Pb-Free".

RoHS Exempt: TI defines "RoHS Exempt" to mean products that contain lead but are compliant with EU RoHS pursuant to a specific EU RoHS exemption.

Green: TI defines "Green" to mean the content of Chlorine (Cl) and Bromine (Br) based flame retardants meet JS709B low halogen requirements of <=100ppm threshold. Antimony trioxide based flame retardants must also meet the <=1000ppm threshold requirement.

(3) MSL, Peak Temp. - The Moisture Sensitivity Level rating according to the JEDEC industry standard classifications, and peak solder temperature.

(4) There may be additional marking, which relates to the logo, the lot trace code information, or the environmental category on the device.

⁽⁵⁾ Multiple Device Markings will be inside parentheses. Only one Device Marking contained in parentheses and separated by a "-" will appear on a device. If a line is indented then it is a continuation of the previous line and the two combined represent the entire Device Marking for that device.

⁽⁶⁾ Lead/Ball Finish - Orderable Devices may have multiple material finish options. Finish options are separated by a vertical ruled line. Lead/Ball Finish values may wrap to two lines if the finish value exceeds the maximum column width.

Important Information and Disclaimer:The information provided on this page represents TI's knowledge and belief as of the date that it is provided. TI bases its knowledge and belief on information provided by third parties, and makes no representation or warranty as to the accuracy of such information. Efforts are underway to better integrate information from third parties. TI has taken and continues to take reasonable steps to provide representative and accurate information but may not have conducted destructive testing or chemical analysis on incoming materials and chemicals. TI and TI suppliers consider certain information to be proprietary, and thus CAS numbers and other limited information may not be available for release.

In no event shall TI's liability arising out of such information exceed the total purchase price of the TI part(s) at issue in this document sold by TI to Customer on an annual basis.

TAPE AND REEL INFORMATION



QUADRANT ASSIGNMENTS FOR PIN 1 ORIENTATION IN TAPE



*All dimensions are nominal

Device	Package Type	Package Drawing	Pins	SPQ	Reel Diameter (mm)	Reel Width W1 (mm)	A0 (mm)	B0 (mm)	K0 (mm)	P1 (mm)	W (mm)	Pin1 Quadrant
ATL431AIDBZR	SOT-23	DBZ	3	3000	178.0	9.2	3.15	2.77	1.22	4.0	8.0	Q3
ATL431AIDBZR	SOT-23	DBZ	3	3000	180.0	8.4	3.15	2.77	1.22	4.0	8.0	Q3
ATL431AQDBZR	SOT-23	DBZ	3	3000	180.0	8.4	3.15	2.77	1.22	4.0	8.0	Q3
ATL431AQDBZR	SOT-23	DBZ	3	3000	178.0	9.2	3.15	2.77	1.22	4.0	8.0	Q3
ATL431BIDBZR	SOT-23	DBZ	3	3000	180.0	8.4	3.15	2.77	1.22	4.0	8.0	Q3
ATL431BIDBZR	SOT-23	DBZ	3	3000	178.0	9.2	3.15	2.77	1.22	4.0	8.0	Q3
ATL431BQDBZR	SOT-23	DBZ	3	3000	180.0	8.4	3.15	2.77	1.22	4.0	8.0	Q3
ATL431BQDBZR	SOT-23	DBZ	3	3000	178.0	9.2	3.15	2.77	1.22	4.0	8.0	Q3
ATL432AIDBZR	SOT-23	DBZ	3	3000	180.0	8.4	3.15	2.77	1.22	4.0	8.0	Q3
ATL432AIDBZR	SOT-23	DBZ	3	3000	178.0	9.2	3.15	2.77	1.22	4.0	8.0	Q3
ATL432AQDBZR	SOT-23	DBZ	3	3000	180.0	8.4	3.15	2.77	1.22	4.0	8.0	Q3
ATL432AQDBZR	SOT-23	DBZ	3	3000	178.0	9.2	3.15	2.77	1.22	4.0	8.0	Q3
ATL432BIDBZR	SOT-23	DBZ	3	3000	180.0	8.4	3.15	2.77	1.22	4.0	8.0	Q3
ATL432BIDBZR	SOT-23	DBZ	3	3000	178.0	9.2	3.15	2.77	1.22	4.0	8.0	Q3
ATL432BQDBZR	SOT-23	DBZ	3	3000	180.0	8.4	3.15	2.77	1.22	4.0	8.0	Q3
ATL432BQDBZR	SOT-23	DBZ	3	3000	178.0	9.2	3.15	2.77	1.22	4.0	8.0	Q3

TAPE AND REEL BOX DIMENSIONS

*All dimensions are nominal

Device	Package Type	Package Drawing	Pins	SPQ	Length (mm)	Width (mm)	Height (mm)
ATL431AIDBZR	SOT-23	DBZ	3	3000	180.0	180.0	18.0
ATL431AIDBZR	SOT-23	DBZ	3	3000	183.0	183.0	20.0
ATL431AQDBZR	SOT-23	DBZ	3	3000	183.0	183.0	20.0
ATL431AQDBZR	SOT-23	DBZ	3	3000	180.0	180.0	18.0
ATL431BIDBZR	SOT-23	DBZ	3	3000	183.0	183.0	20.0
ATL431BIDBZR	SOT-23	DBZ	3	3000	180.0	180.0	18.0
ATL431BQDBZR	SOT-23	DBZ	3	3000	183.0	183.0	20.0
ATL431BQDBZR	SOT-23	DBZ	3	3000	180.0	180.0	18.0
ATL432AIDBZR	SOT-23	DBZ	3	3000	183.0	183.0	20.0
ATL432AIDBZR	SOT-23	DBZ	3	3000	180.0	180.0	18.0
ATL432AQDBZR	SOT-23	DBZ	3	3000	183.0	183.0	20.0
ATL432AQDBZR	SOT-23	DBZ	3	3000	180.0	180.0	18.0
ATL432BIDBZR	SOT-23	DBZ	3	3000	183.0	183.0	20.0
ATL432BIDBZR	SOT-23	DBZ	3	3000	180.0	180.0	18.0
ATL432BQDBZR	SOT-23	DBZ	3	3000	183.0	183.0	20.0
ATL432BQDBZR	SOT-23	DBZ	3	3000	180.0	180.0	18.0

GENERIC PACKAGE VIEW

DBZ 3

SOT-23 - 1.12 mm max height

SMALL OUTLINE TRANSISTOR



Images above are just a representation of the package family, actual package may vary.
Refer to the product data sheet for package details.

4203227/C

DBZ0003A



PACKAGE OUTLINE

SOT-23 - 1.12 mm max height

SMALL OUTLINE TRANSISTOR

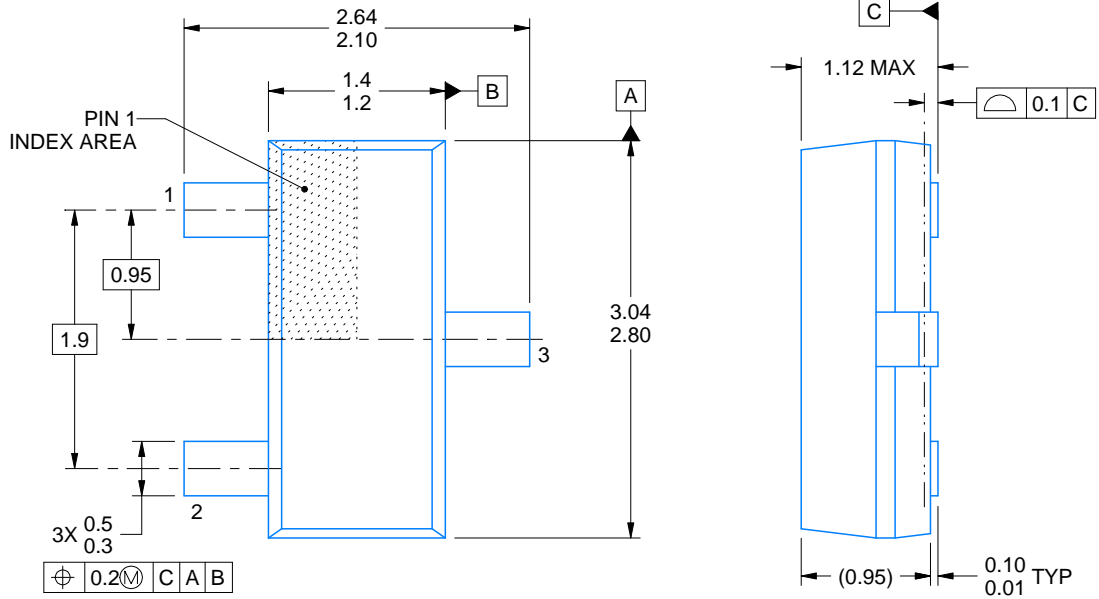

4214838/C 04/2017

NOTES:

1. All linear dimensions are in millimeters. Any dimensions in parenthesis are for reference only. Dimensioning and tolerancing per ASME Y14.5M.
2. This drawing is subject to change without notice.
3. Reference JEDEC registration TO-236, except minimum foot length.

EXAMPLE BOARD LAYOUT

DBZ0003A

SOT-23 - 1.12 mm max height

SMALL OUTLINE TRANSISTOR

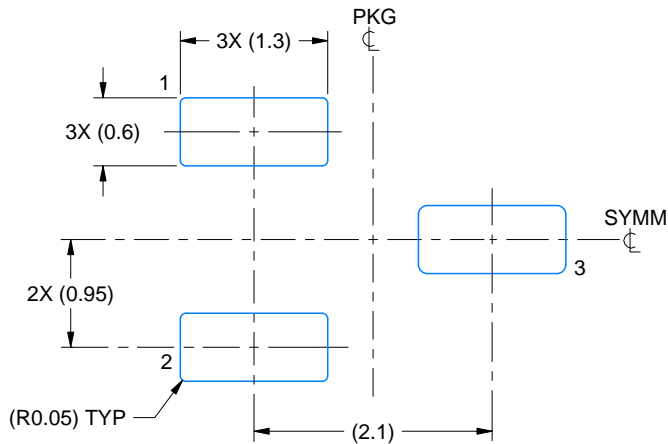

LAND PATTERN EXAMPLE
SCALE:15X

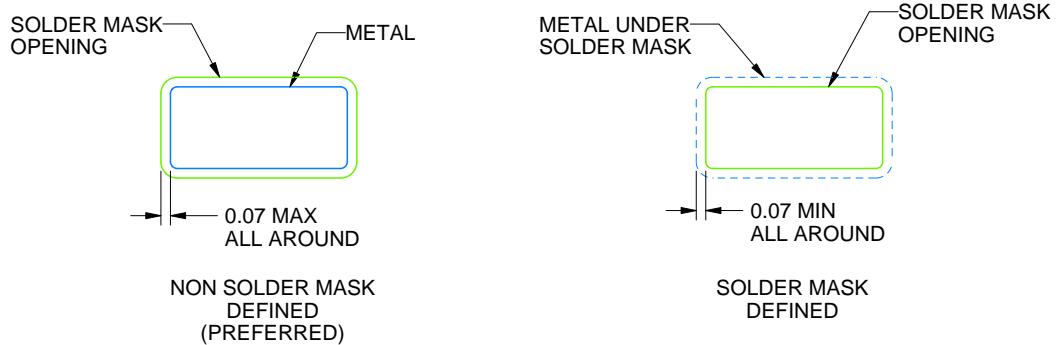

SOLDER MASK DETAILS

4214838/C 04/2017

NOTES: (continued)

4. Publication IPC-7351 may have alternate designs.
5. Solder mask tolerances between and around signal pads can vary based on board fabrication site.

EXAMPLE STENCIL DESIGN

DBZ0003A

SOT-23 - 1.12 mm max height

SMALL OUTLINE TRANSISTOR



SOLDER PASTE EXAMPLE
BASED ON 0.125 THICK STENCIL
SCALE:15X

4214838/C 04/2017

NOTES: (continued)

6. Laser cutting apertures with trapezoidal walls and rounded corners may offer better paste release. IPC-7525 may have alternate design recommendations.
7. Board assembly site may have different recommendations for stencil design.

IMPORTANT NOTICE AND DISCLAIMER

TI PROVIDES TECHNICAL AND RELIABILITY DATA (INCLUDING DATASHEETS), DESIGN RESOURCES (INCLUDING REFERENCE DESIGNS), APPLICATION OR OTHER DESIGN ADVICE, WEB TOOLS, SAFETY INFORMATION, AND OTHER RESOURCES "AS IS" AND WITH ALL FAULTS, AND DISCLAIMS ALL WARRANTIES, EXPRESS AND IMPLIED, INCLUDING WITHOUT LIMITATION ANY IMPLIED WARRANTIES OF MERCHANTABILITY, FITNESS FOR A PARTICULAR PURPOSE OR NON-INFRINGEMENT OF THIRD PARTY INTELLECTUAL PROPERTY RIGHTS.

These resources are intended for skilled developers designing with TI products. You are solely responsible for (1) selecting the appropriate TI products for your application, (2) designing, validating and testing your application, and (3) ensuring your application meets applicable standards, and any other safety, security, or other requirements. These resources are subject to change without notice. TI grants you permission to use these resources only for development of an application that uses the TI products described in the resource. Other reproduction and display of these resources is prohibited. No license is granted to any other TI intellectual property right or to any third party intellectual property right. TI disclaims responsibility for, and you will fully indemnify TI and its representatives against, any claims, damages, costs, losses, and liabilities arising out of your use of these resources.

TI's products are provided subject to TI's Terms of Sale (www.ti.com/legal/termsofsale.html) or other applicable terms available either on ti.com or provided in conjunction with such TI products. TI's provision of these resources does not expand or otherwise alter TI's applicable warranties or warranty disclaimers for TI products.

Mailing Address: Texas Instruments, Post Office Box 655303, Dallas, Texas 75265
Copyright © 2018, Texas Instruments Incorporated

Looking for pricing, stock, or lifecycle information?

Click below to explore more details on WIN SOURCE:

 [View TL432BIDBZR on WIN SOURCE](#)

 [Texas Instruments](#) Information

Optimize Your Supply Chain with WIN SOURCE Solutions

-  Global Sourcing Solution
-  Obsolete Management
-  Cost Control Management
-  Shortage Management
-  Alternative Solution
-  Excess Inventory Management