



THE DATASHEET OF TL082IDRQ1



FEATURES

- Qualified for Automotive Applications
- Low Power Consumption
- Wide Common-Mode and Differential Voltage Ranges
- Low Input Bias and Offset Currents
- Low Total Harmonic Distortion: 0.003% Typ
- High Input Impedance: JFET-Input Stage
- Latchup-Free Operation
- High Slew Rate: 13 V/ μ s Typ
- Common-Mode Input Voltage Range Includes V_{CC+}

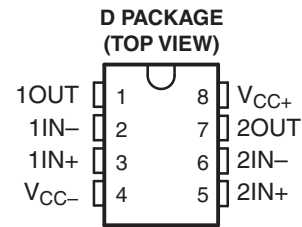

DESCRIPTION/ORDERING INFORMATION

The TL082 JFET-input operational amplifier incorporates well-matched, high-voltage JFET and bipolar transistors in a monolithic integrated circuit. The device features high slew rates, low input bias and offset currents, and low offset-voltage temperature coefficient.

The I-suffix device is characterized for operation from -40°C to 85°C . The Q-suffix device is characterized for operation from -40°C to 125°C .

ORDERING INFORMATION⁽¹⁾

T_J	PACKAGE ⁽²⁾		ORDERABLE PART NUMBER	TOP-SIDE MARKING
-40°C to 85°C	SOIC – D	Reel of 2500	TL082IDRQ1	TL082I
-40°C to 125°C	SOIC – D	Reel of 2500	TL082QDRQ1	TL082Q

- (1) For the most current package and ordering information, see the Package Option Addendum at the end of this document, or see the TI web site at www.ti.com.
- (2) Package drawings, thermal data, and symbolization are available at www.ti.com/packaging.



Please be aware that an important notice concerning availability, standard warranty, and use in critical applications of Texas Instruments semiconductor products and disclaimers thereto appears at the end of this data sheet.

SYMBOL (EACH AMPLIFIER)

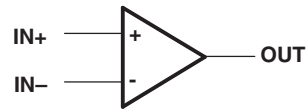

SCHEMATIC (EACH AMPLIFIER)

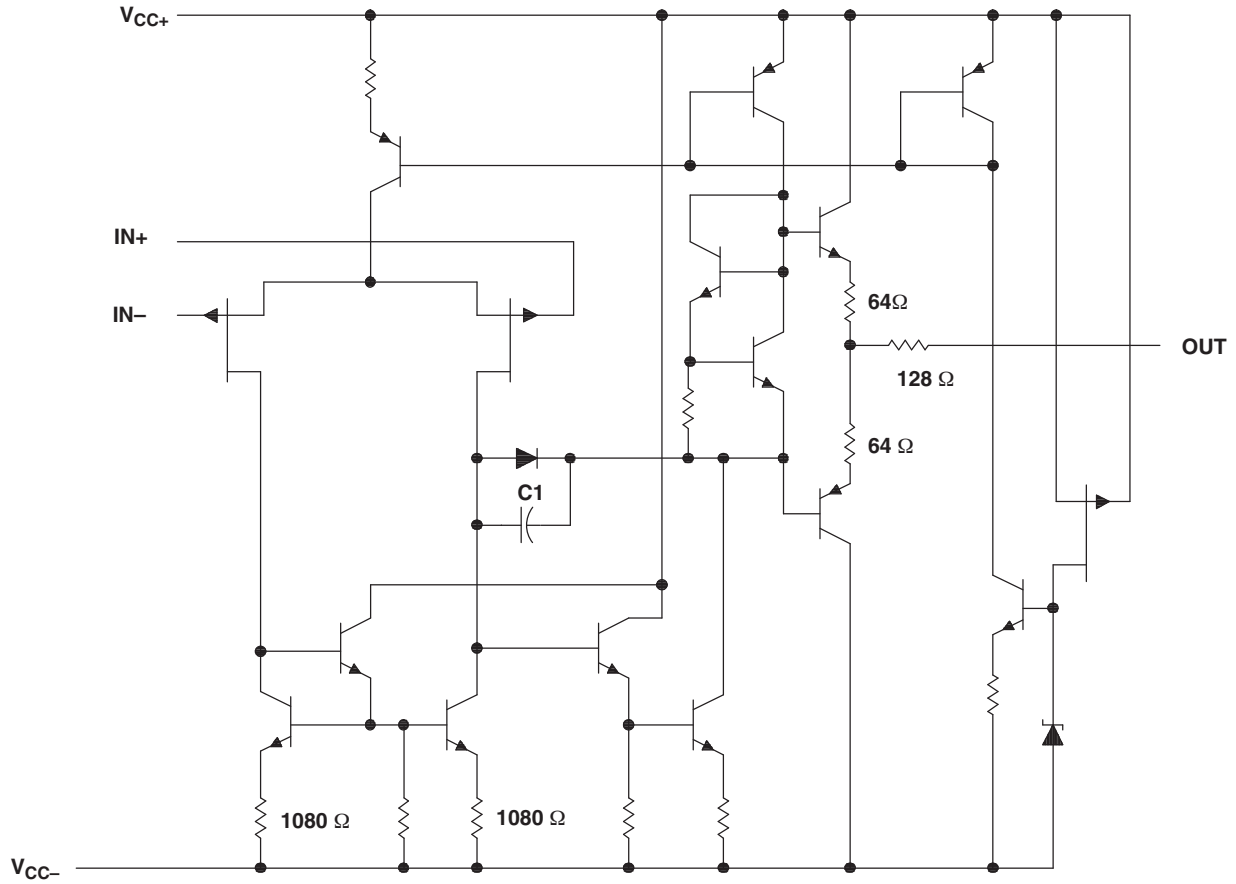

A. Component values shown are nominal.

ABSOLUTE MAXIMUM RATINGS⁽¹⁾

over operating free-air temperature range (unless otherwise noted)

		VALUE	
V _{CC+}	Supply voltage, positive ⁽²⁾	18 V	
V _{CC-}	Supply voltage, negative ⁽²⁾	–18 V	
V _{ID}	Differential input voltage ⁽³⁾	±30 V	
V _I	Input voltage ⁽²⁾⁽⁴⁾	±15 V	
	Duration of output short circuit ⁽⁵⁾	Unlimited	
	Continuous total power dissipation	⁽⁶⁾	
T _A	Operating free-air temperature range	TL082I	–40°C to 85°C
		TL082Q	–40°C to 125°C
θ _{JA}	Package thermal impedance, junction to free air ⁽⁷⁾	97°C/W	
ESD rating ⁽⁸⁾	Human-Body Model	1.5 kV (H1C)	
	Charged-Device Model	1.5 kV (C5)	
	Machine Model	200 V (M3)	
	Operating virtual junction temperature	150°C	
T _{stg}	Storage temperature range	–65°C to 150°C	

- (1) Stresses beyond those listed under "absolute maximum ratings" may cause permanent damage to the device. These are stress ratings only, and functional operation of the device at these or any other conditions beyond those indicated under "recommended operating conditions" is not implied. Exposure to absolute-maximum-rated conditions for extended periods may affect device reliability.
- (2) All voltage values, except differential voltages, are with respect to the midpoint between V_{CC+} and V_{CC-}.
- (3) Differential voltages are at IN+ with respect to IN–.
- (4) The magnitude of the input voltage must never exceed the magnitude of the supply voltage or 15 V, whichever is less.
- (5) The output may be shorted to ground or to either supply. Temperature and/or supply voltages must be limited to ensure that the dissipation rating is not exceeded.
- (6) Maximum power dissipation is a function of T_{J(max)}, θ_{JA}, and T_A. The maximum allowable power dissipation at any allowable ambient temperature is PD = (T_{J(max)} – T_A)/θ_{JA}. Operating at the absolute maximum T_J of 150°C can affect reliability.
- (7) The package thermal impedance is calculated in accordance with JESD 51-7.
- (8) ESD protection level per JEDEC classifications JESD22-A114 (HBM), JESD22-A115 (MM), and JESD22-C101 (CDM).

ELECTRICAL CHARACTERISTICS⁽¹⁾

$V_{CC\pm} = \pm 15\text{ V}$ (unless otherwise noted)

PARAMETER		TEST CONDITIONS	T_A ⁽²⁾	MIN	TYP	MAX	UNIT
V_{IO}	Input offset voltage	$V_O = 0, R_S = 50\ \Omega$	25°C		3	6	mV
			Full range			9	
α_{VIO}	Temperature coefficient of input offset voltage	$V_O = 0, R_S = 50\ \Omega$	Full range		18		$\mu\text{V}/^\circ\text{C}$
I_{IO}	Input offset current ⁽³⁾	$V_O = 0$	25°C		5	100	pA
			Full range			20	nA
I_{IB}	Input bias current ⁽³⁾	$V_O = 0$	25°C		30	200	pA
			Full range			50	nA
V_{ICR}	Common-mode input voltage range		25°C	± 11	-12 to 15		V
V_{OM}	Maximum peak output voltage swing	$R_L = 10\ \text{k}\Omega$	25°C	± 12	± 13.5		V
		$R_L \geq 10\ \text{k}\Omega$	Full range	± 12			
		$R_L \geq 2\ \text{k}\Omega$		± 10	± 12		
A_{VD}	Large-signal differential voltage amplification	$V_O = \pm 10\ \text{V}, R_L \geq 2\ \text{k}\Omega$	25°C	50	200		V/mV
			Full range	15			
B1	Unity-gain bandwidth		25°C		3		MHz
r_i	Input resistance		25°C		10^{12}		Ω
CMRR	Common-mode rejection ratio	$V_{IC} = V_{ICR}(\text{min}), V_O = 0, R_S = 50\ \Omega$	25°C	75	86		dB
k_{SVR}	Supply-voltage rejection ratio ($\Delta V_{CC\pm}/\Delta V_{IO}$)	$V_{CC} = \pm 15\ \text{V}$ to $\pm 9\ \text{V}$, $V_O = 0, R_S = 50\ \Omega$	25°C	80	86		dB
I_{CC}	Supply current (per amplifier)	$V_O = 0$, No load	25°C		1.4	2.8	mA
V_{O1}/V_{O2}	Crosstalk attenuation	$A_{VD} = 100$	25°C		120		dB

- (1) All characteristics are measured under open-loop conditions with zero common-mode voltage, unless otherwise specified.
(2) Full range for T_A is -40°C to 85°C for I-suffix devices and -40°C to 125°C for Q-suffix devices.
(3) Input bias currents of an FET-input operational amplifier are normal junction reverse currents, which are temperature sensitive, as shown in Figure 14. Pulse techniques must be used that maintain the junction temperature as close to the ambient temperature as possible.

OPERATING CHARACTERISTICS

$V_{CC\pm} = \pm 15\ \text{V}$, $T_A = 25^\circ\text{C}$ (unless otherwise noted)

PARAMETER		TEST CONDITIONS	MIN	TYP	MAX	UNIT
SR	Slew rate at unity gain	$V_I = 10\ \text{V}, R_L = 2\ \text{k}\Omega, C_L = 100\ \text{pF}$, See Figure 1	8	13		$\text{V}/\mu\text{s}$
t_r	Rise time	$V_I = 20\ \text{mV}, R_L = 2\ \text{k}\Omega, C_L = 100\ \text{pF}$, See Figure 1		0.05		μs
	Overshoot factor	$V_I = 20\ \text{mV}, R_L = 2\ \text{k}\Omega, C_L = 100\ \text{pF}$, See Figure 1		20		%
V_n	Equivalent input noise voltage	$R_S = 20\ \Omega$	$f = 1\ \text{kHz}$		18	$\text{nV}/\sqrt{\text{Hz}}$
			$f = 10\ \text{Hz}$ to $10\ \text{kHz}$		4	μV
I_n	Equivalent input noise current	$R_S = 20\ \Omega, f = 1\ \text{kHz}$		0.01		$\text{pA}/\sqrt{\text{Hz}}$
THD	Total harmonic distortion	$V_{I\text{rms}} = 6\ \text{V}, f = 1\ \text{kHz}, \text{AVD} = 1, R_S \leq 1\ \text{k}\Omega, R_L \geq 2\ \text{k}\Omega$		0.003		%

PARAMETER MEASUREMENT INFORMATION

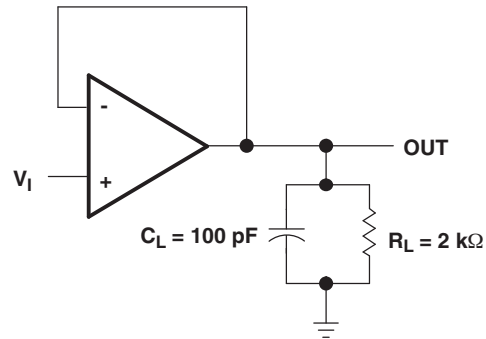

Figure 1.

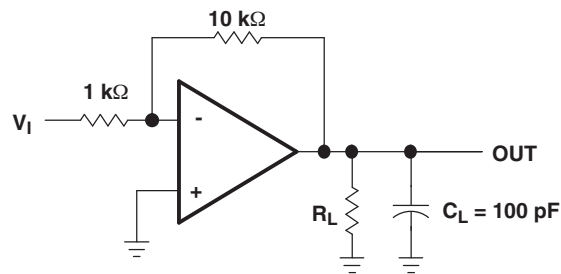

Figure 2.

TYPICAL CHARACTERISTICS

Data at high and low temperatures are applicable only within the rated operating free-air temperature ranges of the devices.

Table of Graphs

		FIGURE	
V_{OM}	Maximum peak output voltage	vs Frequency	3, 4, 5
		vs Free-air temperature	6
		vs Load resistance	7
		vs Supply voltage	8
A_{VD}	Large-signal differential voltage amplification	vs Free-air temperature	9
		vs Frequency	10
P_D	Total power dissipation	vs Free-air temperature	11
I_{CC}	Supply current	vs Free-air temperature	12
		vs Supply voltage	13
I_{IB}	Input bias current	vs Free-air temperature	14
		Large-signal pulse response	vs Time
V_O	Output voltage	vs Elapsed time	16
CMRR	Common-mode rejection ratio	vs Free-air temperature	17
V_n	Equivalent input noise voltage	vs Frequency	18
THD	Total harmonic distortion	vs Frequency	19

MAXIMUM PEAK OUTPUT VOLTAGE
vs
FREQUENCY
(See Figure 2)

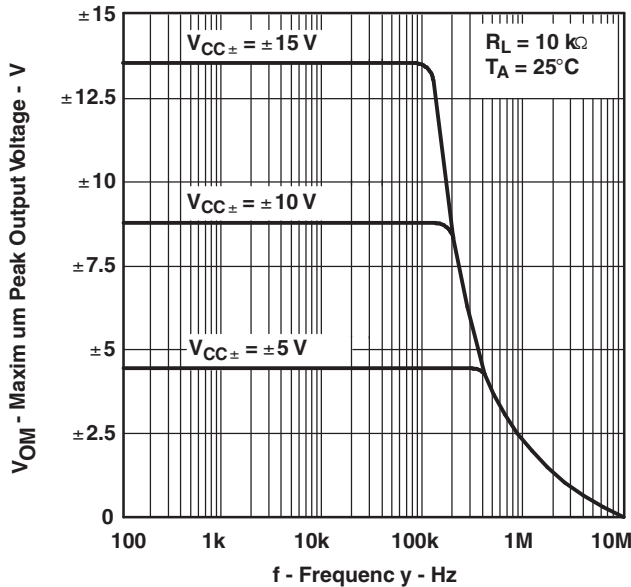

Figure 3.

MAXIMUM PEAK OUTPUT VOLTAGE
vs
FREQUENCY
(See Figure 2)

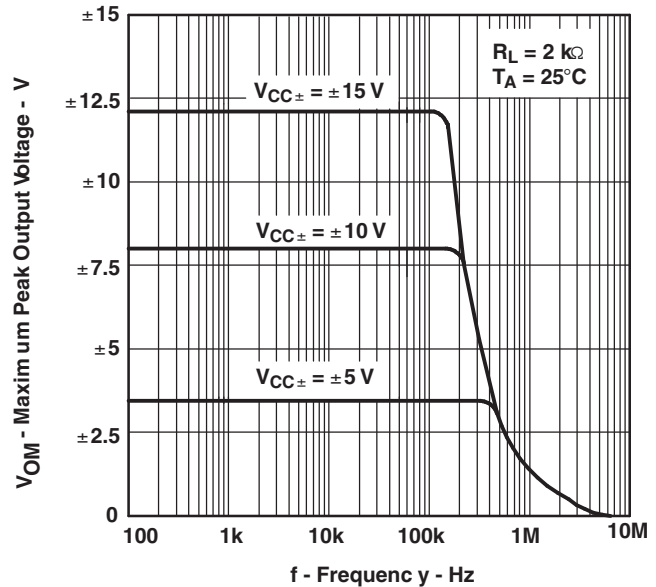

Figure 4.

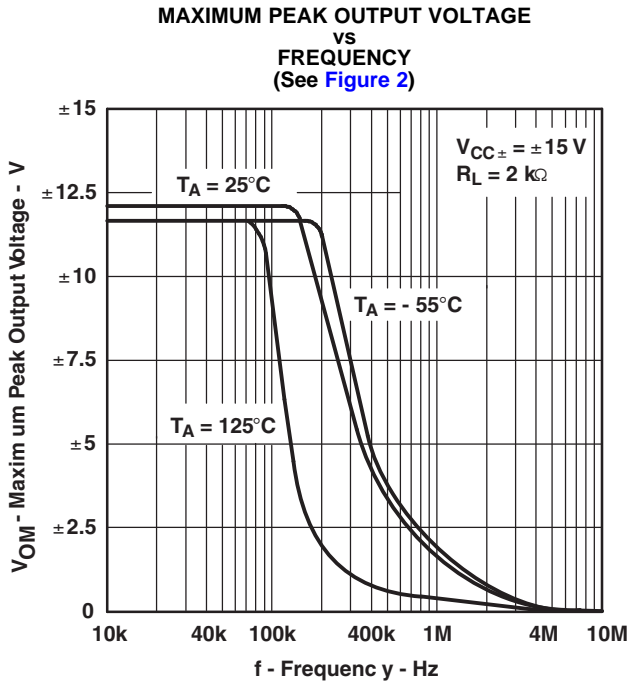

Figure 5.

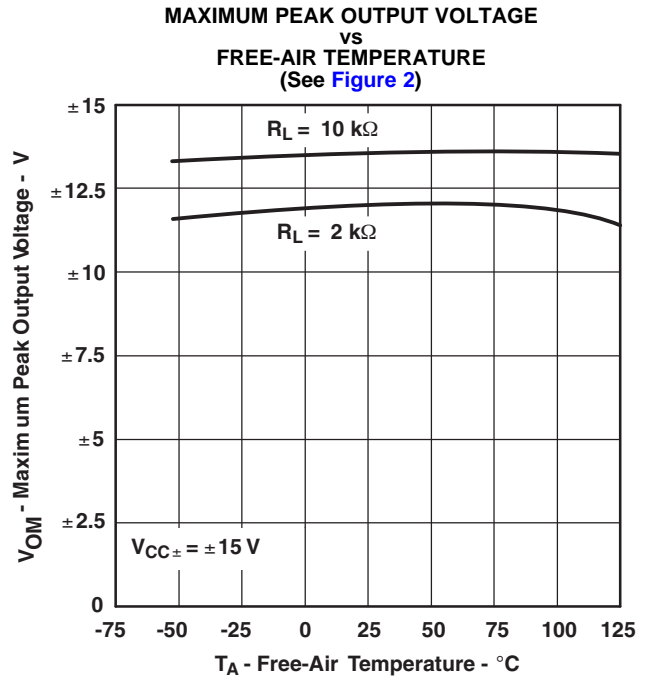

Figure 6.

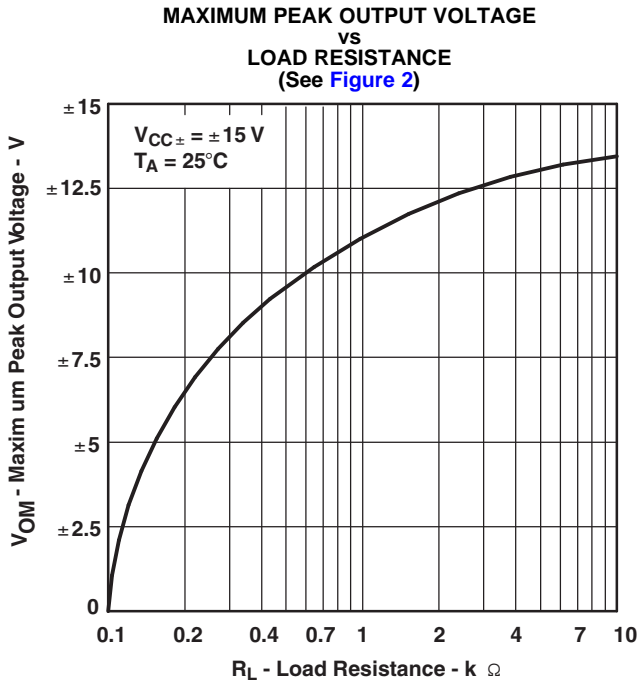

Figure 7.

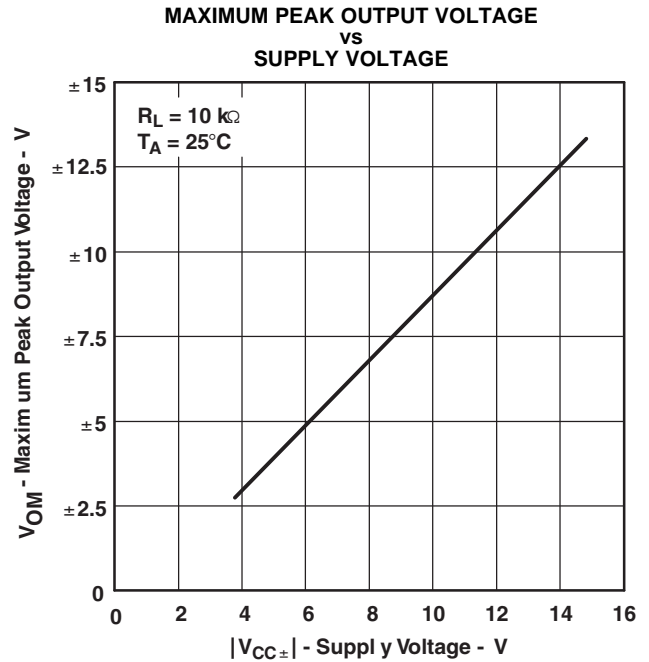

Figure 8.

**LARGE-SIGNAL DIFFERENTIAL VOLTAGE AMPLIFICATION
 VS
 FREE-AIR TEMPERATURE**

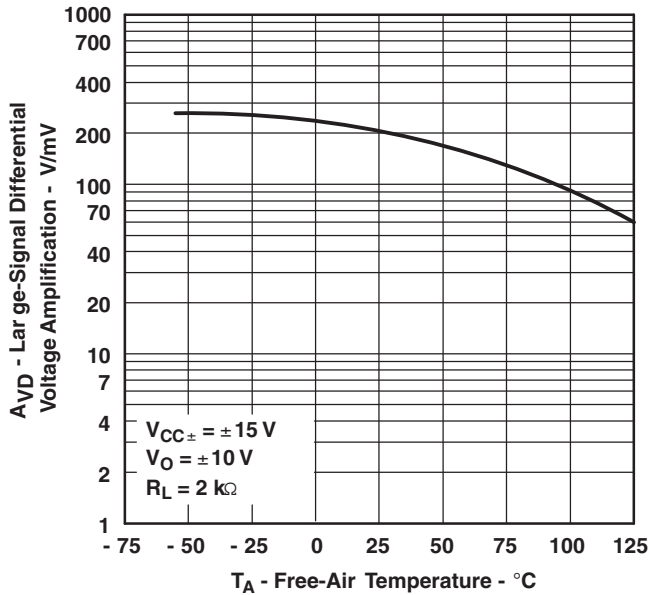

Figure 9.

**LARGE-SIGNAL DIFFERENTIAL VOLTAGE AMPLIFICATION
 VS
 FREQUENCY**

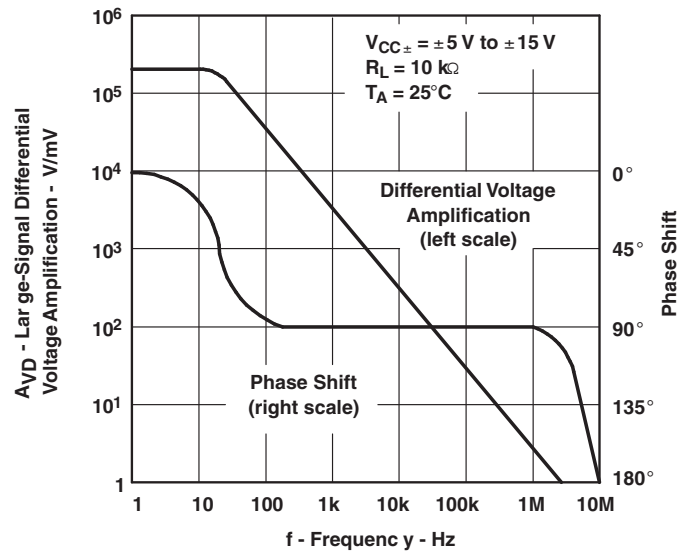

Figure 10.

**POWER DISSIPATION
 VS
 FREE-AIR TEMPERATURE**

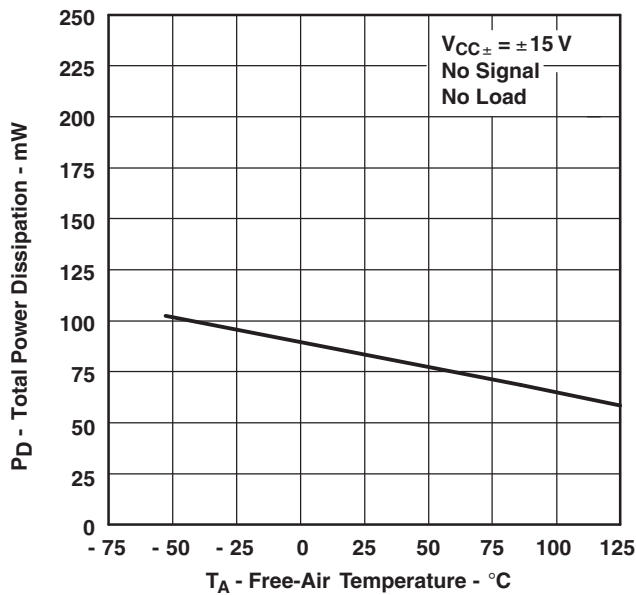

Figure 11.

**SUPPLY CURRENT
 VS
 FREE-AIR TEMPERATURE**

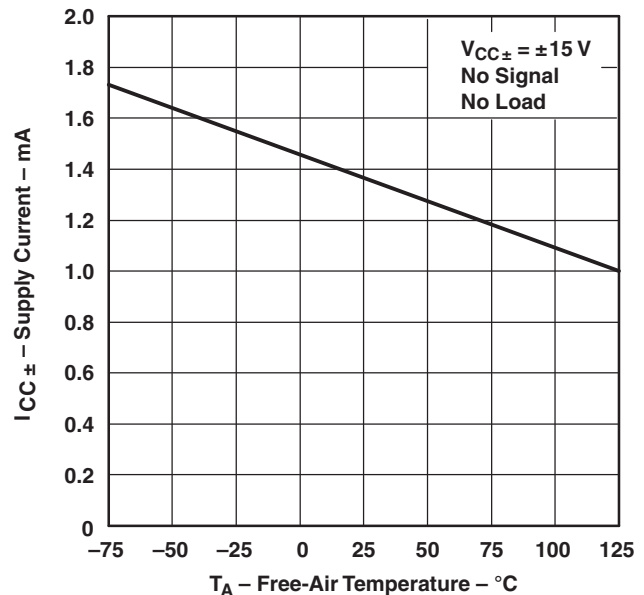

Figure 12.

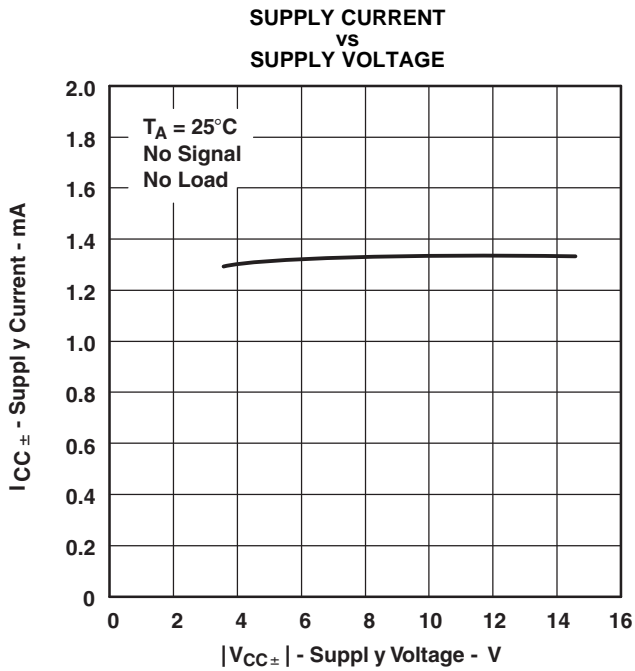

Figure 13.

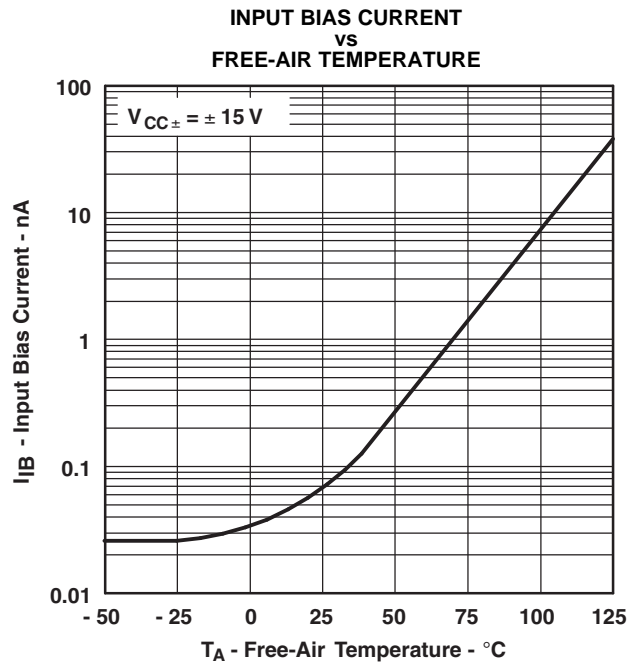

Figure 14.

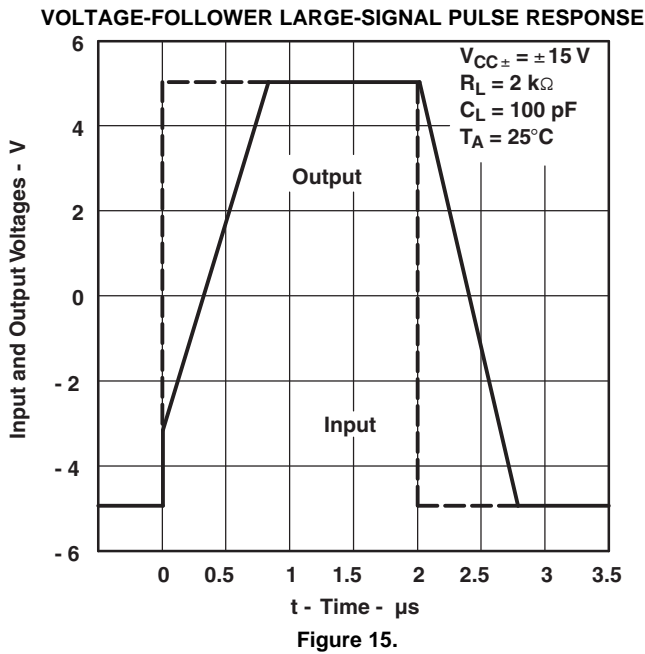

Figure 15.

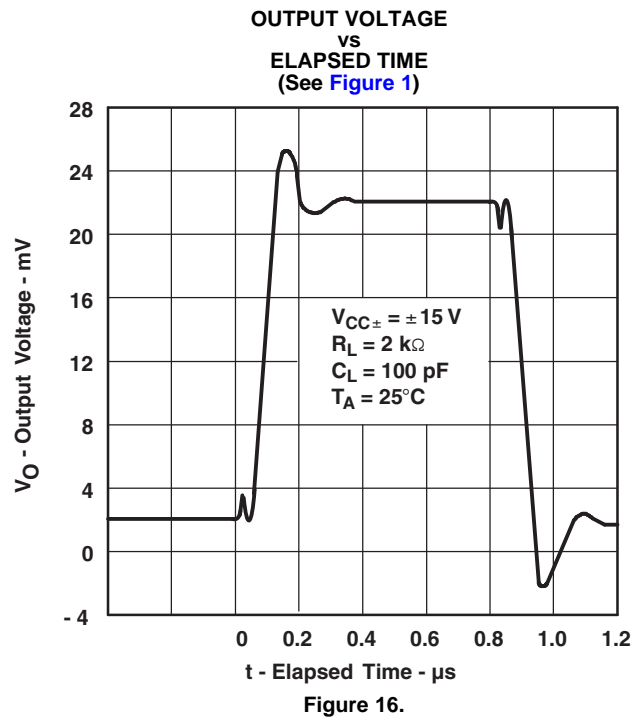

Figure 16.

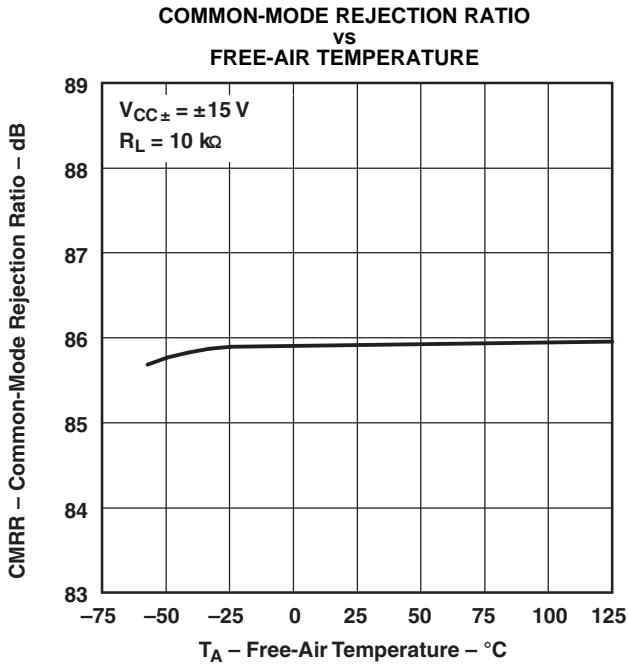

Figure 17.

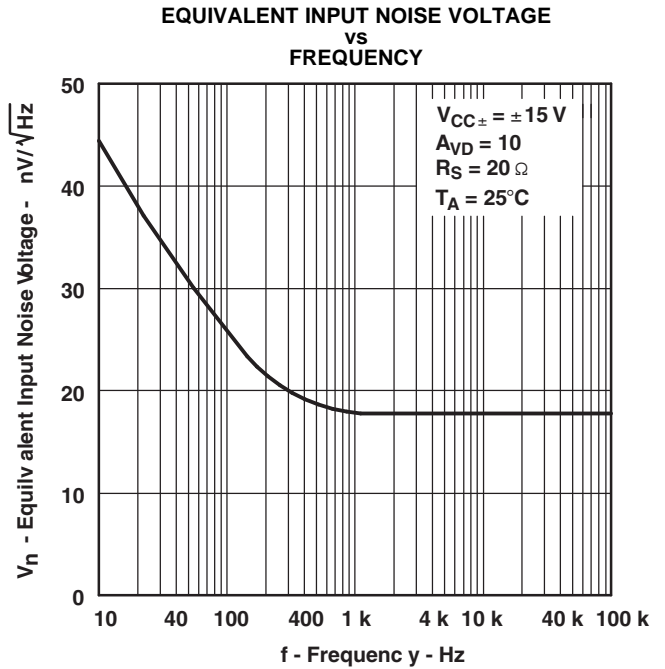

Figure 18.

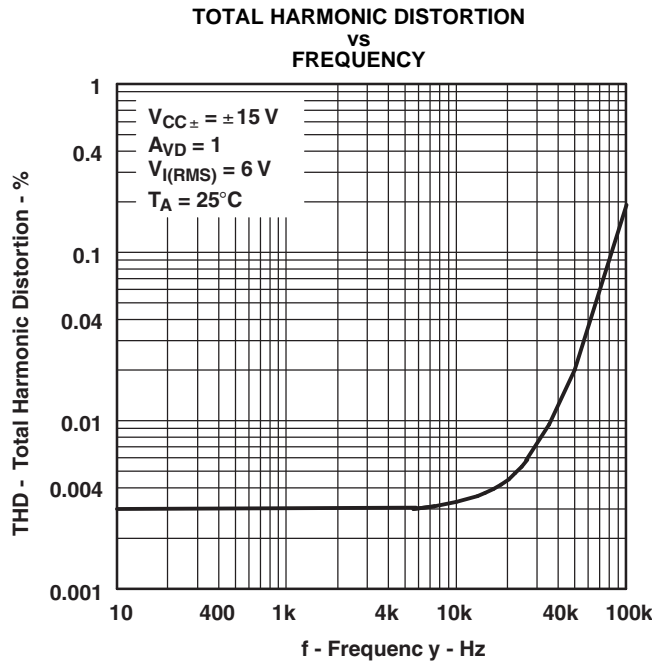

Figure 19.

APPLICATION INFORMATION

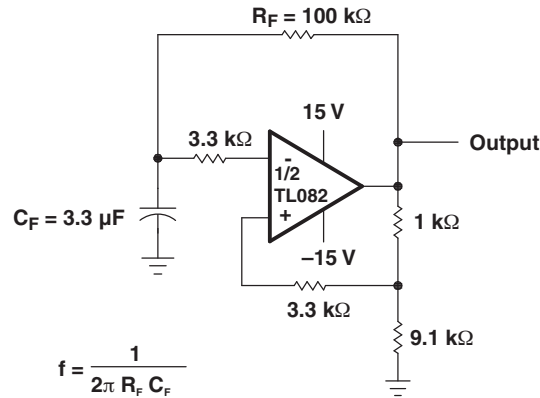

Figure 20.

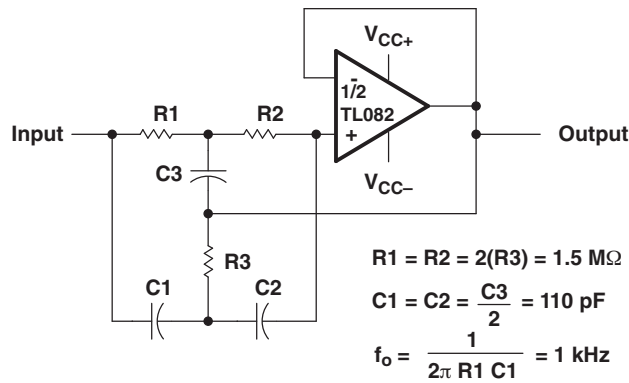

Figure 21.

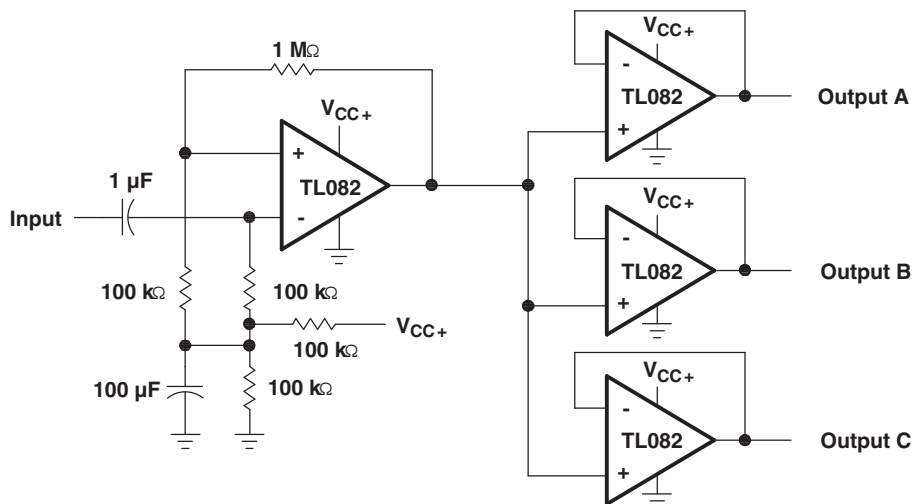
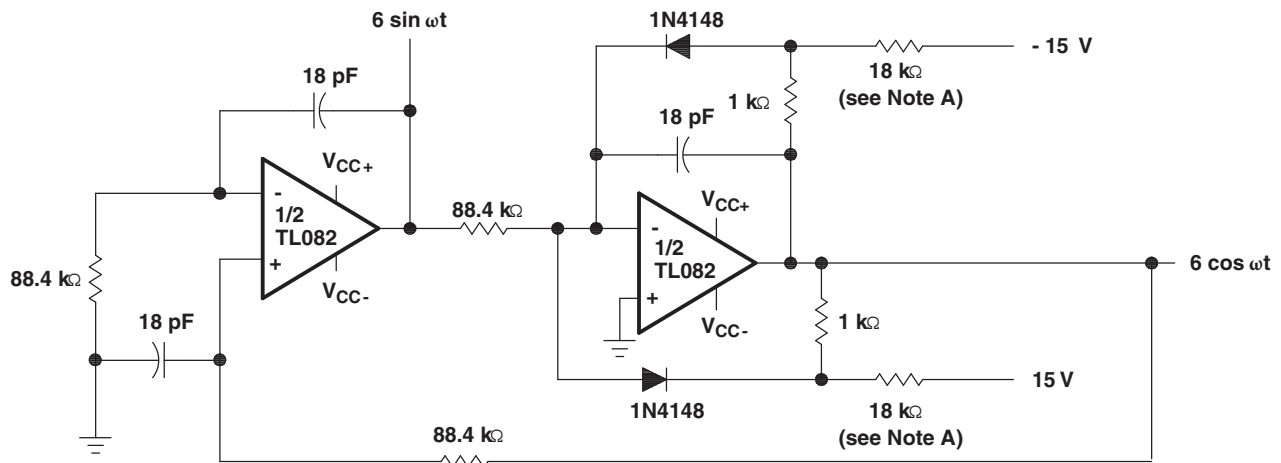

Figure 22. Audio-Distribution Amplifier



A. These resistor values may be adjusted for a symmetrical output.

Figure 23. 100-kHz Quadrature Oscillator

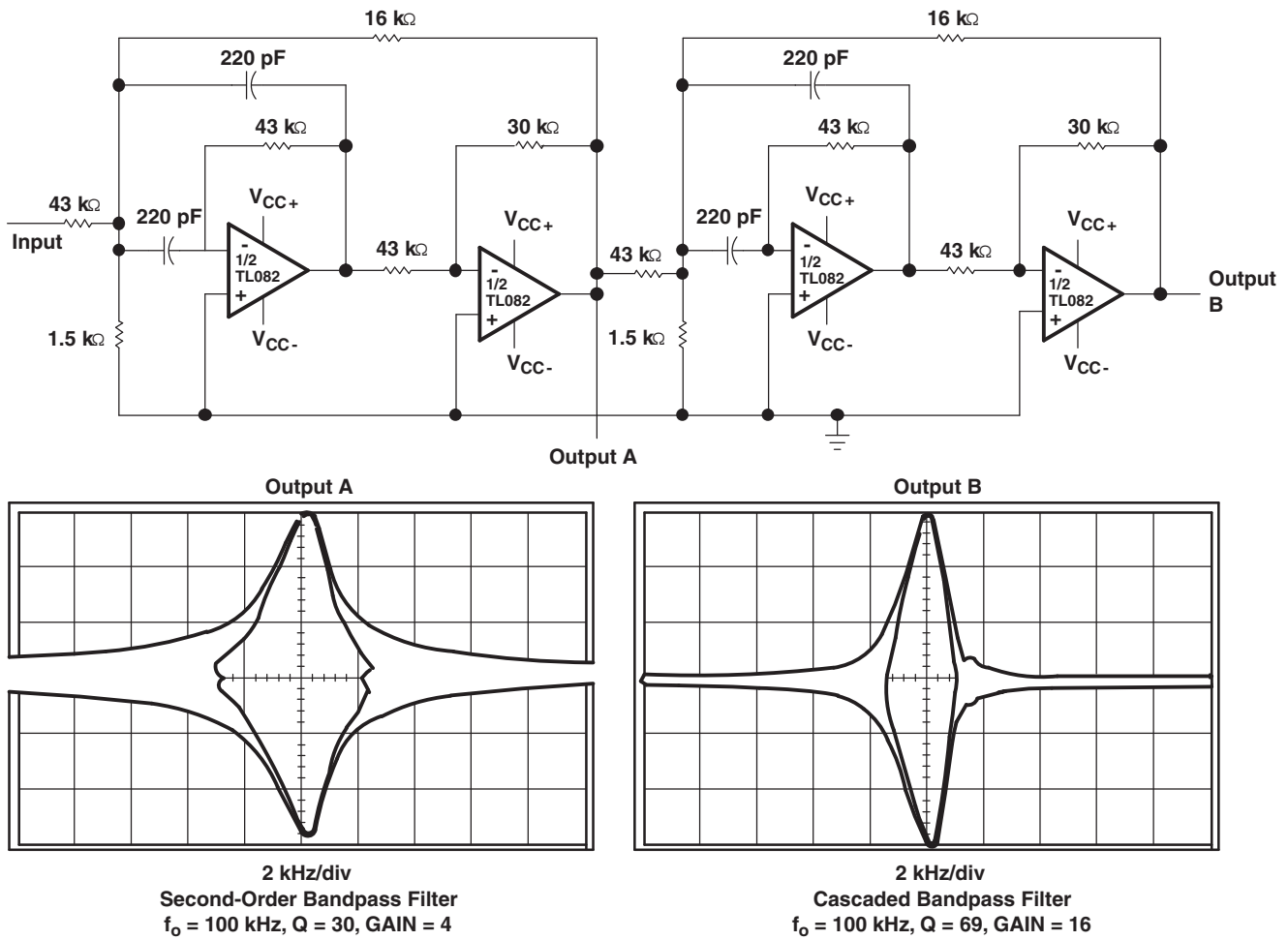

Figure 24. Positive-Feedback Bandpass Filter

PACKAGING INFORMATION

Orderable Device	Status (1)	Package Type	Package Drawing	Pins	Package Qty	Eco Plan (2)	Lead finish/ Ball material (6)	MSL Peak Temp (3)	Op Temp (°C)	Device Marking (4/5)	Samples
TL082IDRQ1	ACTIVE	SOIC	D	8	2500	RoHS & Green	NIPDAU	Level-1-260C-UNLIM	-40 to 85	TL082I	Samples
TL082QDRQ1	ACTIVE	SOIC	D	8	2500	RoHS & Green	NIPDAU	Level-1-260C-UNLIM	-40 to 125	TL082Q	Samples

(1) The marketing status values are defined as follows:

ACTIVE: Product device recommended for new designs.

LIFEBUY: TI has announced that the device will be discontinued, and a lifetime-buy period is in effect.

NRND: Not recommended for new designs. Device is in production to support existing customers, but TI does not recommend using this part in a new design.

PREVIEW: Device has been announced but is not in production. Samples may or may not be available.

OBsolete: TI has discontinued the production of the device.

(2) **RoHS:** TI defines "RoHS" to mean semiconductor products that are compliant with the current EU RoHS requirements for all 10 RoHS substances, including the requirement that RoHS substance do not exceed 0.1% by weight in homogeneous materials. Where designed to be soldered at high temperatures, "RoHS" products are suitable for use in specified lead-free processes. TI may reference these types of products as "Pb-Free".

RoHS Exempt: TI defines "RoHS Exempt" to mean products that contain lead but are compliant with EU RoHS pursuant to a specific EU RoHS exemption.

Green: TI defines "Green" to mean the content of Chlorine (Cl) and Bromine (Br) based flame retardants meet JS709B low halogen requirements of <=1000ppm threshold. Antimony trioxide based flame retardants must also meet the <=1000ppm threshold requirement.

(3) MSL, Peak Temp. - The Moisture Sensitivity Level rating according to the JEDEC industry standard classifications, and peak solder temperature.

(4) There may be additional marking, which relates to the logo, the lot trace code information, or the environmental category on the device.

(5) Multiple Device Markings will be inside parentheses. Only one Device Marking contained in parentheses and separated by a "~" will appear on a device. If a line is indented then it is a continuation of the previous line and the two combined represent the entire Device Marking for that device.

(6) Lead finish/Ball material - Orderable Devices may have multiple material finish options. Finish options are separated by a vertical ruled line. Lead finish/Ball material values may wrap to two lines if the finish value exceeds the maximum column width.

Important Information and Disclaimer:The information provided on this page represents TI's knowledge and belief as of the date that it is provided. TI bases its knowledge and belief on information provided by third parties, and makes no representation or warranty as to the accuracy of such information. Efforts are underway to better integrate information from third parties. TI has taken and continues to take reasonable steps to provide representative and accurate information but may not have conducted destructive testing or chemical analysis on incoming materials and chemicals. TI and TI suppliers consider certain information to be proprietary, and thus CAS numbers and other limited information may not be available for release.

In no event shall TI's liability arising out of such information exceed the total purchase price of the TI part(s) at issue in this document sold by TI to Customer on an annual basis.

OTHER QUALIFIED VERSIONS OF TL082-Q1 :

- Catalog: [TL082](#)
- Military: [TL082M](#)

NOTE: Qualified Version Definitions:

- Catalog - TI's standard catalog product
- Military - QML certified for Military and Defense Applications



D0008A

PACKAGE OUTLINE

SOIC - 1.75 mm max height

SMALL OUTLINE INTEGRATED CIRCUIT



4214825/C 02/2019

NOTES:

- Linear dimensions are in inches [millimeters]. Dimensions in parenthesis are for reference only. Controlling dimensions are in inches. Dimensioning and tolerancing per ASME Y14.5M.
- This drawing is subject to change without notice.
- This dimension does not include mold flash, protrusions, or gate burrs. Mold flash, protrusions, or gate burrs shall not exceed $.006$ [0.15] per side.
- This dimension does not include interlead flash.
- Reference JEDEC registration MS-012, variation AA.

EXAMPLE BOARD LAYOUT

D0008A

SOIC - 1.75 mm max height

SMALL OUTLINE INTEGRATED CIRCUIT



LAND PATTERN EXAMPLE
EXPOSED METAL SHOWN
SCALE:8X



SOLDER MASK DETAILS

4214825/C 02/2019

NOTES: (continued)

- 6. Publication IPC-7351 may have alternate designs.
- 7. Solder mask tolerances between and around signal pads can vary based on board fabrication site.

EXAMPLE STENCIL DESIGN

D0008A

SOIC - 1.75 mm max height

SMALL OUTLINE INTEGRATED CIRCUIT



SOLDER PASTE EXAMPLE
BASED ON .005 INCH [0.125 MM] THICK STENCIL
SCALE:8X

4214825/C 02/2019

NOTES: (continued)

8. Laser cutting apertures with trapezoidal walls and rounded corners may offer better paste release. IPC-7525 may have alternate design recommendations.
9. Board assembly site may have different recommendations for stencil design.

IMPORTANT NOTICE AND DISCLAIMER

TI PROVIDES TECHNICAL AND RELIABILITY DATA (INCLUDING DATASHEETS), DESIGN RESOURCES (INCLUDING REFERENCE DESIGNS), APPLICATION OR OTHER DESIGN ADVICE, WEB TOOLS, SAFETY INFORMATION, AND OTHER RESOURCES "AS IS" AND WITH ALL FAULTS, AND DISCLAIMS ALL WARRANTIES, EXPRESS AND IMPLIED, INCLUDING WITHOUT LIMITATION ANY IMPLIED WARRANTIES OF MERCHANTABILITY, FITNESS FOR A PARTICULAR PURPOSE OR NON-INFRINGEMENT OF THIRD PARTY INTELLECTUAL PROPERTY RIGHTS.

These resources are intended for skilled developers designing with TI products. You are solely responsible for (1) selecting the appropriate TI products for your application, (2) designing, validating and testing your application, and (3) ensuring your application meets applicable standards, and any other safety, security, or other requirements. These resources are subject to change without notice. TI grants you permission to use these resources only for development of an application that uses the TI products described in the resource. Other reproduction and display of these resources is prohibited. No license is granted to any other TI intellectual property right or to any third party intellectual property right. TI disclaims responsibility for, and you will fully indemnify TI and its representatives against, any claims, damages, costs, losses, and liabilities arising out of your use of these resources.

TI's products are provided subject to TI's Terms of Sale (www.ti.com/legal/termsofsale.html) or other applicable terms available either on ti.com or provided in conjunction with such TI products. TI's provision of these resources does not expand or otherwise alter TI's applicable warranties or warranty disclaimers for TI products.

Mailing Address: Texas Instruments, Post Office Box 655303, Dallas, Texas 75265
Copyright © 2020, Texas Instruments Incorporated

Looking for pricing, stock, or lifecycle information?

Click below to explore more details on WIN SOURCE:

 [View TL082IDRQ1](#) on WIN SOURCE

 [Texas Instruments](#) Information

Optimize Your Supply Chain with WIN SOURCE Solutions

-  Global Sourcing Solution
-  Obsolete Management
-  Cost Control Management
-  Shortage Management
-  Alternative Solution
-  Excess Inventory Management