



THE DATASHEET OF TL082BCDT



General purpose JFET dual operation amplifiers

Datasheet - production data

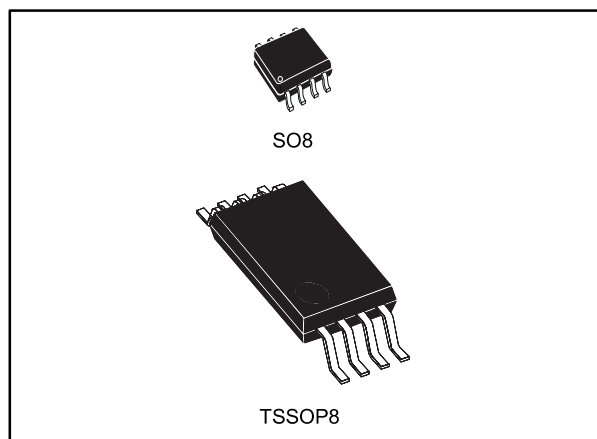
**Description**

The TL082, TL082A and TL082B are high speed JFET input dual operational amplifiers incorporating well-matched, high voltage JFET and bipolar transistors in a monolithic integrated circuit.

The devices feature high slew rates, low input bias and offset current, and low offset voltage temperature coefficient.

Features

- Wide common-mode (up to V_{CC+}) and differential voltage range
- Low input bias and offset current
- Output short-circuit protection
- High input impedance JFET input stage
- Internal frequency compensation
- Latch up free operation
- High slew rate: 16 V/ μ s (typical)

Contents

1	Schematic diagram.....	3
2	Pin connections.....	4
3	Absolute maximum ratings and operating conditions	5
4	Electrical characteristics	6
5	Electrical characteristic curves	8
6	Parameter measurement information	11
7	Typical applications	12
8	Package information	13
	8.1 SO8 package information.....	14
	8.2 TSSOP8 package information.....	15
9	Ordering information.....	16
10	Revision history	17

1 Schematic diagram

Figure 1: Schematic diagram

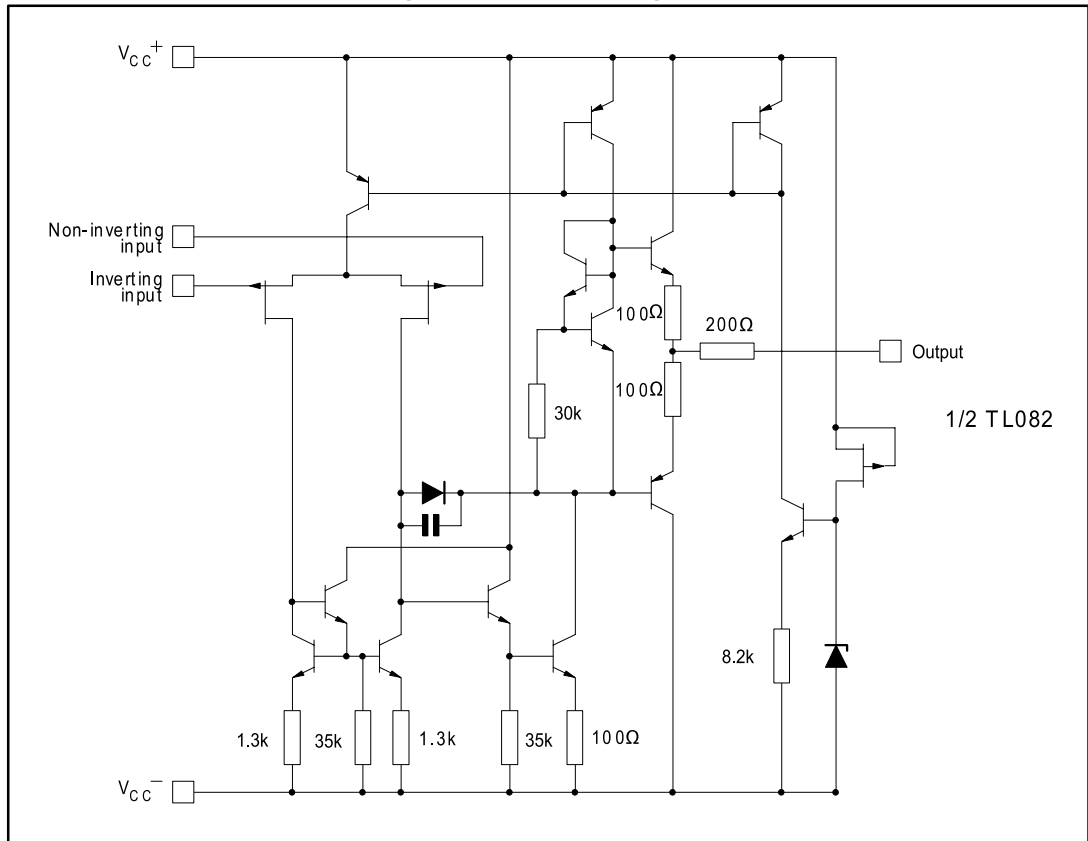

2 Pin connections

Figure 2: Pin connections (top view)

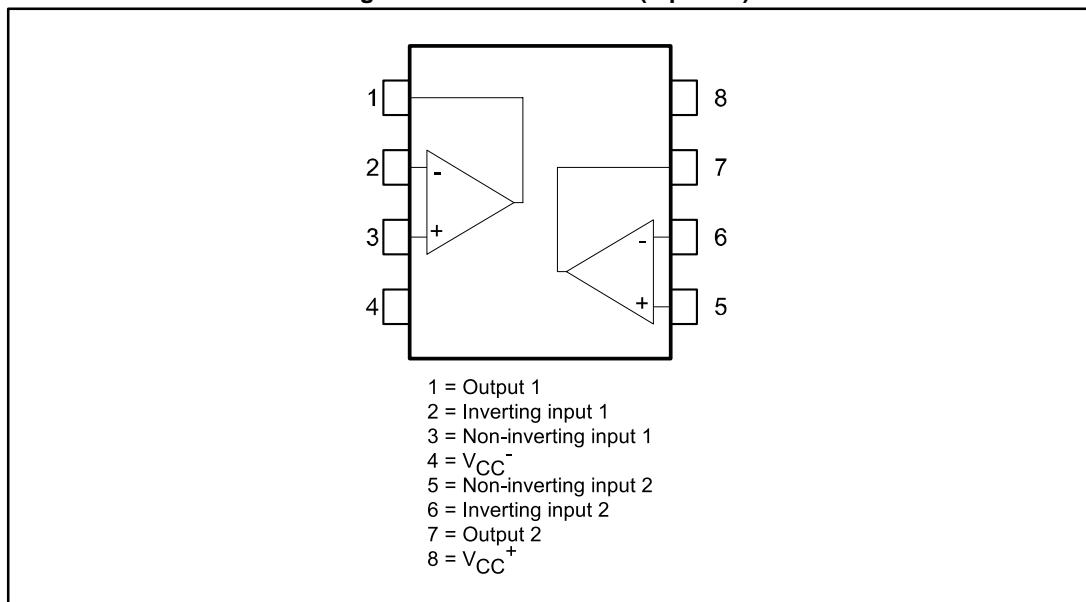

3 Absolute maximum ratings and operating conditions

Table 1: Absolute maximum ratings

Symbol	Parameter	TL082I, AI, BI	TL082C, AC, BC	Unit
V _{CC}	Supply voltage ⁽¹⁾	±18		V
V _{in}	Input voltage ⁽²⁾	±15		
V _{id}	Differential input voltage ⁽³⁾	±30		
P _{tot}	Power dissipation	680		mW
R _{thja}	Thermal resistance junction-to-ambient ⁽⁴⁾	SO8	125	°C/W
		TSSOP8	120	
R _{thjc}	Thermal resistance junction-to-case	SO8	40	
		TSSOP8	37	
	Output short-circuit duration ⁽⁵⁾	Infinite		
T _{stg}	Storage temperature range	-65 to 150		°C
ESD	HBM: human body model ⁽⁶⁾	1		kV
	MM: machine model ⁽⁷⁾	200		V
	CDM: charged device model ⁽⁸⁾	1500		

Notes:

- ⁽¹⁾All voltage values, except differential voltage, are with respect to the zero reference level (ground) of the supply voltages where the zero reference level is the midpoint between V_{CC}⁺ and V_{CC}⁻.
- ⁽²⁾The magnitude of the input voltage must never exceed the magnitude of the supply voltage or 15 volts, whichever is less.
- ⁽³⁾Differential voltages are the non-inverting input terminal with respect to the inverting input terminal.
- ⁽⁴⁾Short-circuits can cause excessive heating. Destructive dissipation can result from simultaneous short-circuit on all amplifiers.
- ⁽⁵⁾The output may be shorted to ground or to either supply. Temperature and/or supply voltages must be limited to ensure that the dissipation rating is not exceeded
- ⁽⁶⁾Human body model: 100 pF discharged through a 1.5 kΩ resistor between two pins of the device, done for all couples of pin combinations with other pins floating.
- ⁽⁷⁾Machine model: a 200 pF cap is charged to the specified voltage, then discharged directly between two pins of the device with no external series resistor (internal resistor < 5 Ω), done for all couples of pin combinations with other pins floating.
- ⁽⁸⁾Charged device model: all pins plus package are charged together to the specified voltage and then discharged directly to the ground.

Table 2: Operating conditions

Symbol	Parameter	TL082I, AI, BI	TL082C, AC, BC	Unit
V _{CC}	Supply voltage	6 to 36		V
T _{oper}	Operating free-air temperature range	-40 to 105	0 to 70	°C

4 Electrical characteristics

Table 3: VCC = ±15V, Tamb = +25°C (unless otherwise specified)

Symbol	Parameter	TL082I, AC, AI, BC, BI			TL082C			Unit
		Min.	Typ.	Max.	Min.	Typ.	Max.	
V _{io}	Input offset voltage, R _s = 50 Ω, T _{amb} = 25 °C, TL082		3	10		3	10	mV
	Input offset voltage, R _s = 50 Ω, T _{amb} = 25 °C, TL082A		3	6				
	Input offset voltage, R _s = 50 Ω, T _{amb} = 25 °C, TL082B		1	3				
	Input offset voltage, R _s = 50 Ω, T _{min} ≤ T _{amb} ≤ T _{max} , TL082			13			13	
	Input offset voltage, R _s = 50 Ω, T _{min} ≤ T _{amb} ≤ T _{max} , TL082A			7				
	Input offset voltage, R _s = 50 Ω, T _{min} ≤ T _{amb} ≤ T _{max} , TL082B			5				
DV _{io}	Input offset voltage drift		10			10		μV/°C
I _{io}	Input offset current, T _{amb} = 25 °C ⁽¹⁾		5	100		5	100	pA
	Input offset current, T _{min} ≤ T _{amb} ≤ T _{max} ⁽¹⁾			4			10	nA
I _{ib}	Input bias current, T _{amb} = 25 °C		20	200		20	400	pA
	Input bias current, T _{min} ≤ T _{amb} ≤ T _{max}			20			20	nA
A _{vd}	Large signal voltage gain, R _L = 2 kΩ, V _o = ±10 V, T _{amb} = 25 °C	50	200		25	200		V/mV
	Large signal voltage gain, R _L = 2 kΩ, V _o = ±10 V, T _{min} ≤ T _{amb} ≤ T _{max}	25			15			
SVR	Supply voltage rejection ratio, R _S = 50 Ω, T _{amb} = 25 °C	80	86		70	86		dB
	Supply voltage rejection ratio, R _S = 50 Ω, T _{min} ≤ T _{amb} ≤ T _{max}	80			70			
I _{cc}	Supply current, no load, T _{amb} = 25 °C		1.4	2.5		1.4	2.5	mA
	Supply current, no load, T _{min} ≤ T _{amb} ≤ T _{max}			2.5			2.5	
V _{icm}	Input common mode voltage range	±11	15		±11	15		V
			-12			-12		
CMR	Common mode rejection ratio, R _S = 50 Ω, T _{amb} = 25 °C	80	86		70	86		dB
	Common mode rejection ratio, R _S = 50 Ω, T _{min} ≤ T _{amb} ≤ T _{max}	80			70			
I _{os}	Output short-circuit current, T _{amb} = 25 °C	10	40	60	10	40	60	mA
	Output short-circuit current, T _{min} ≤ T _{amb} ≤ T _{max}	10		60	10		60	

Symbol	Parameter	TL082I, AC, AI, BC, BI			TL082C			Unit
		Min.	Typ.	Max.	Min.	Typ.	Max.	
$\pm V_{opp}$	Output voltage swing, $T_{amb} = 25\text{ }^{\circ}\text{C}$, $R_L = 2\text{ k}\Omega$	10	12		10	12		V
	Output voltage swing, $T_{amb} = 25\text{ }^{\circ}\text{C}$, $R_L = 10\text{ k}\Omega$	12	13.5		12	13.5		
	Output voltage swing, $T_{min} \leq T_{amb} \leq T_{max}$, $R_L = 2\text{ k}\Omega$	10			10			
	Output voltage swing, $T_{min} \leq T_{amb} \leq T_{max}$, $R_L = 10\text{ k}\Omega$	12			12			
SR	Slew rate, $T_{amb} = 25\text{ }^{\circ}\text{C}$, $V_{in} = 10\text{ V}$, $R_L = 2\text{ k}\Omega$, $C_L = 100\text{ pF}$, unity gain	8	16		8	16		V/ μs
t_r	Rise time, $T_{amb} = 25\text{ }^{\circ}\text{C}$, $V_{in} = 20\text{ mV}$, $R_L = 2\text{ k}\Omega$, $C_L = 100\text{ pF}$, unity gain		0.1			0.1		μs
K_{ov}	Overshoot, $T_{amb} = 25\text{ }^{\circ}\text{C}$, $V_{in} = 20\text{ mV}$, $R_L = 2\text{ k}\Omega$, $C_L = 100\text{ pF}$, unity gain		10			10		%
GBP	Gain bandwidth product, $T_{amb} = 25\text{ }^{\circ}\text{C}$, $V_{in} = 10\text{ mV}$, $R_L = 2\text{ k}\Omega$, $C_L = 100\text{ pF}$, $F = 100\text{ kHz}$	2.5	4		2.5	4		MHz
R_i	Input resistance		10^{12}			10^{12}		Ω
THD	Total harmonic distortion, $T_{amb} = 25\text{ }^{\circ}\text{C}$, $F = 1\text{ kHz}$, $R_L = 2\text{ k}\Omega$, $C_L = 100\text{ pF}$, $A_v = 20\text{ dB}$, $V_o = 2\text{ V}_{pp}$		0.01			0.01		%
e_n	Equivalent input noise voltage, $R_s = 100\text{ }\Omega$, $F = 1\text{ kHz}$		15			15		nV/ $\sqrt{\text{Hz}}$
ϕ_m	Phase margin		45			45		degrees
V_{o1}/V_{o2}	Channel separation, $A_v = 100$		120			120		dB

Notes:

(1)The input bias currents are junction leakage currents which approximately double for every 10°C increase in the junction temperature.

5 Electrical characteristic curves

Figure 3: Maximum peak-to-peak output voltage versus frequency

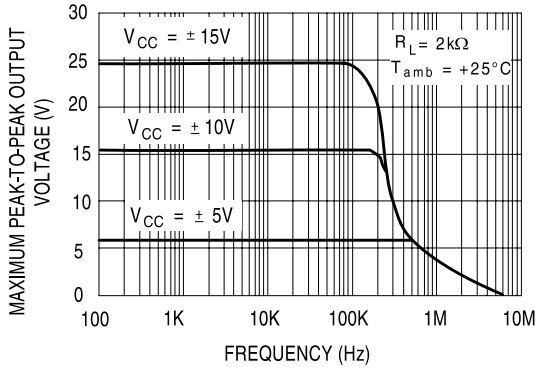

Figure 4: Maximum peak-to-peak output voltage versus frequency

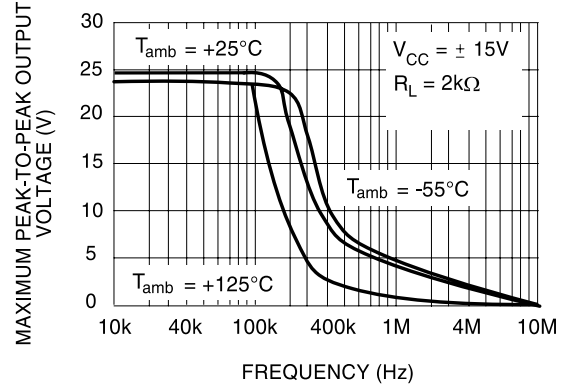

Figure 5: Maximum peak-to-peak output voltage versus load resistance

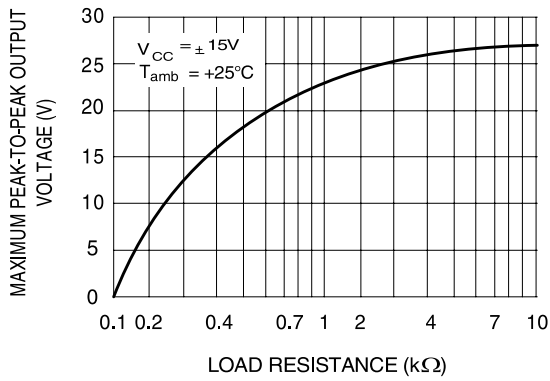

Figure 6: Maximum peak-to-peak output voltage versus frequency

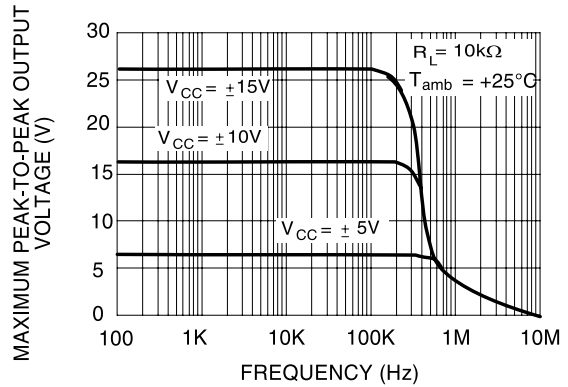

Figure 7: Maximum peak-to-peak output voltage versus free air temperature

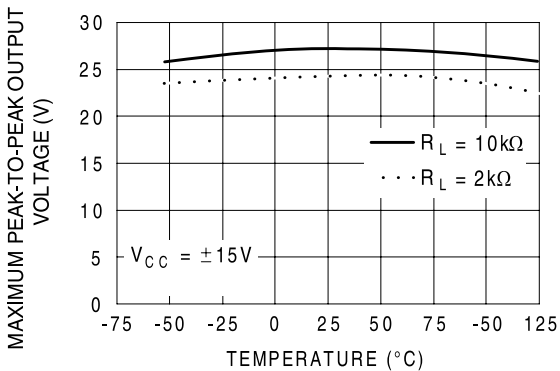

Figure 8: Maximum peak-to-peak output voltage versus supply voltage

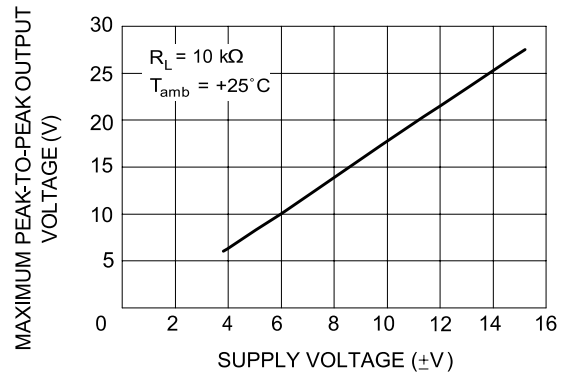

Figure 9: Input bias current versus free air temperature

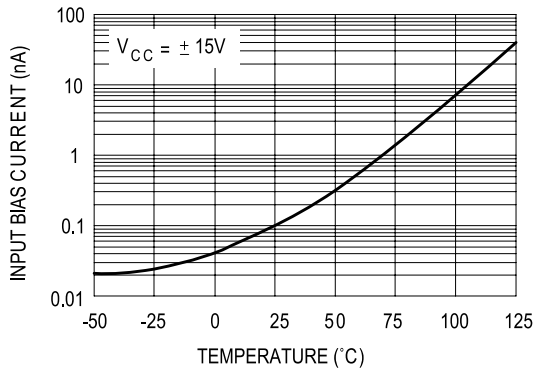

Figure 10: Large signal differential voltage amplification and phase shift versus frequency

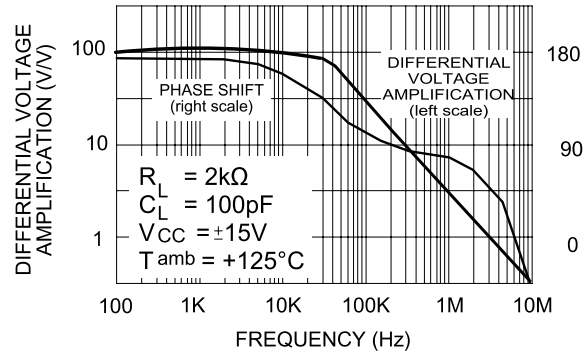

Figure 11: Supply current per amplifier versus free air temperature

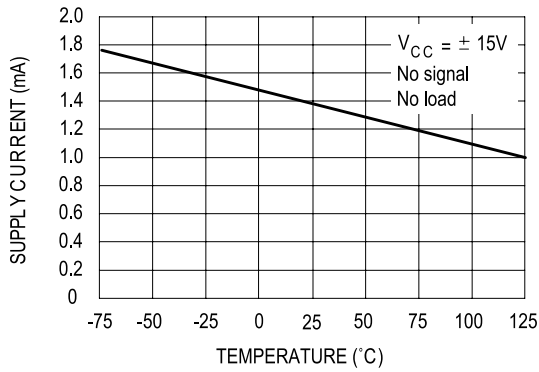

Figure 12: Large signal differential voltage amplification versus free air temperature

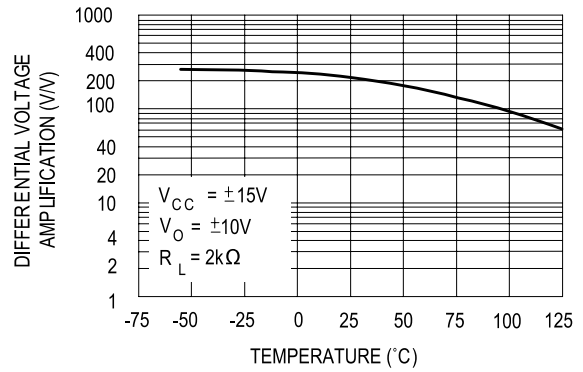

Figure 13: Total power dissipation versus free air temperature

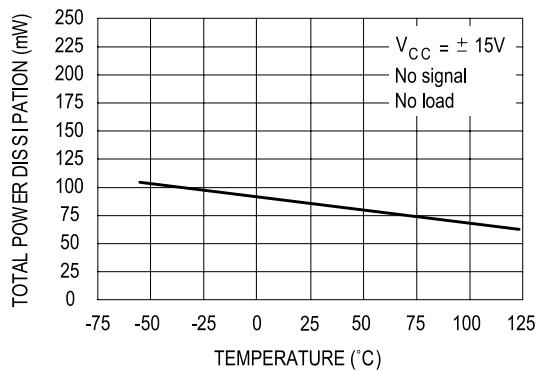

Figure 14: Supply current per amplifier versus supply voltage

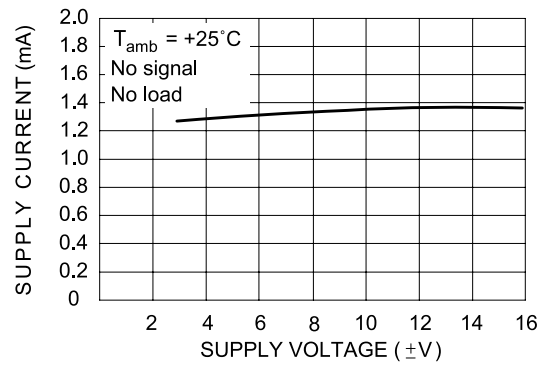

Figure 15: Common-mode rejection ratio versus free air temperature

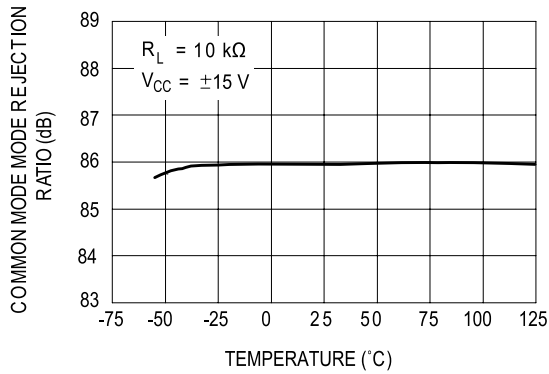

Figure 16: Output voltage versus elapsed time

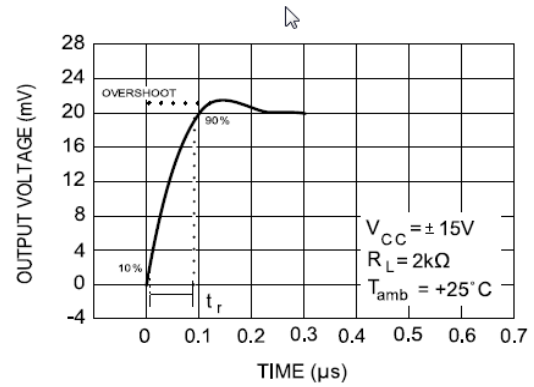

Figure 17: Voltage follower large signal pulse response

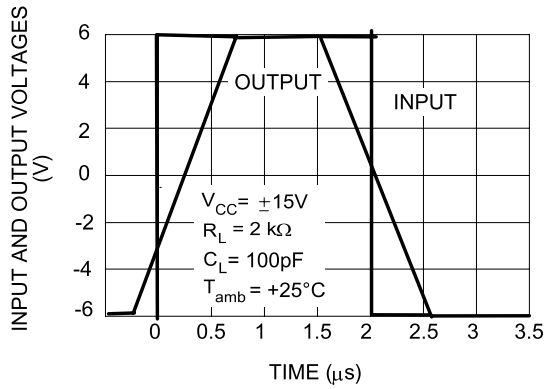

Figure 18: Equivalent input noise voltage versus frequency

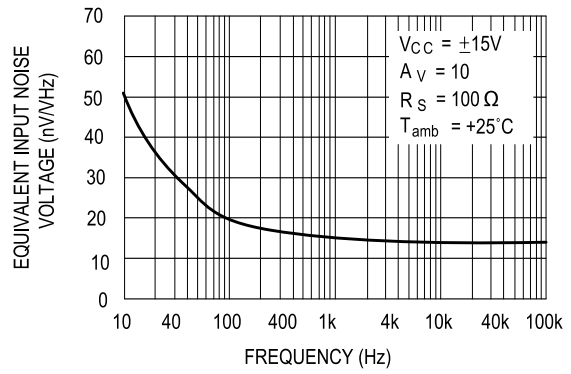
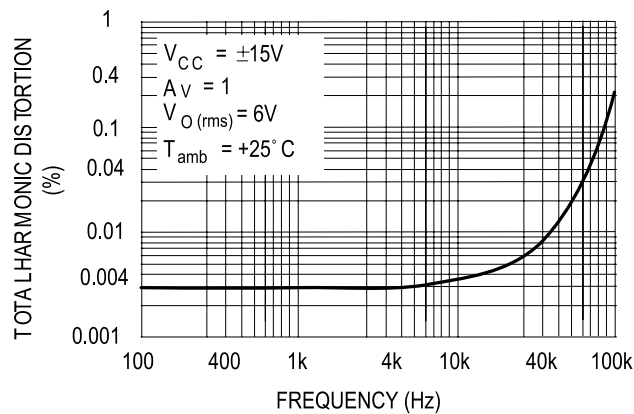

Figure 19: Total harmonic distortion versus frequency



6 Parameter measurement information

Figure 20: Voltage follower

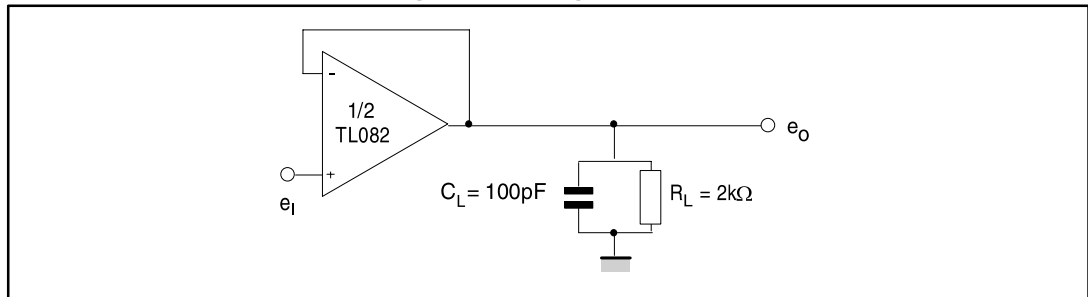
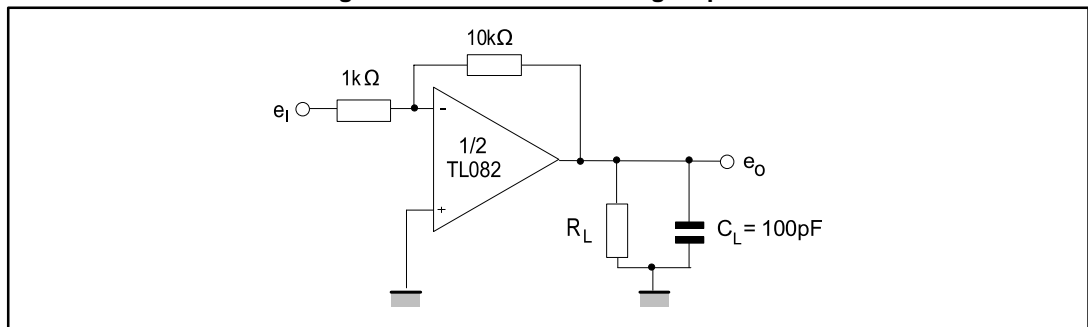
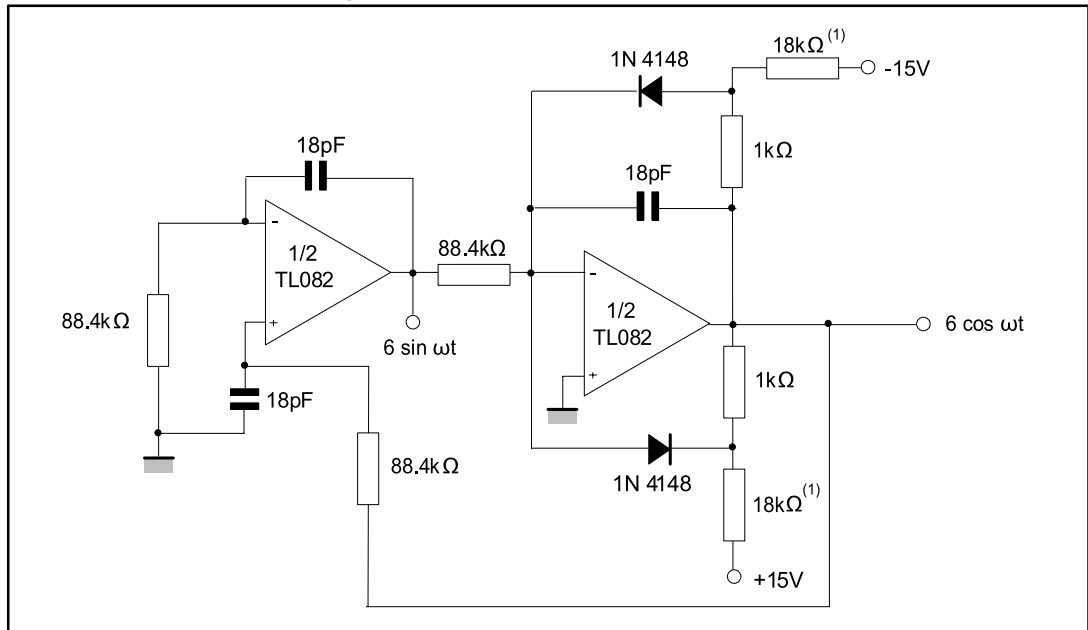

Figure 21: Gain-of-10 inverting amplifier



7 Typical applications

Figure 22: 100 kHz quadruple oscillator



1. These resistor values may be adjusted for a symmetrical output

8 Package information

In order to meet environmental requirements, ST offers these devices in different grades of ECOPACK® packages, depending on their level of environmental compliance. ECOPACK® specifications, grade definitions and product status are available at: www.st.com. ECOPACK® is an ST trademark.

8.1 SO8 package information

Figure 23: SO8 package outline

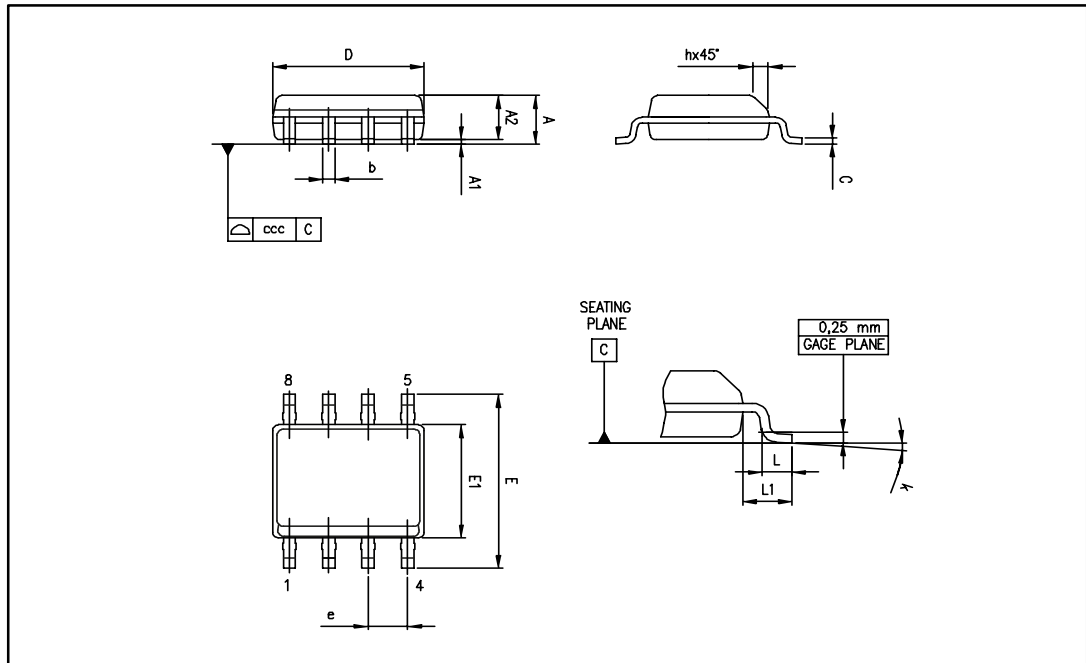

Table 4: SO8 mechanical data

Ref.	Dimensions					
	Millimeters			Inches		
	Min.	Typ.	Max.	Min.	Typ.	Max
A			1.75			0.069
A1	0.10		0.25	0.004		0.010
A2	1.25			0.049		
b	0.28		0.48	0.011		0.019
c	0.17		0.23	0.007		0.010
D	4.80	4.90	5.00	0.189	0.193	0.197
E	5.80	6.00	6.20	0.228	0.236	0.244
E1	3.80	3.90	4.00	0.150	0.154	0.157
e		1.27			0.050	
h	0.25		0.50	0.010		0.020
L	0.40		1.27	0.016		0.050
L1		1.04			0.040	
k	1°		8°	1°		8°
ccc			0.10			0.004

8.2 TSSOP8 package information

Figure 24: TSSOP8 package outline

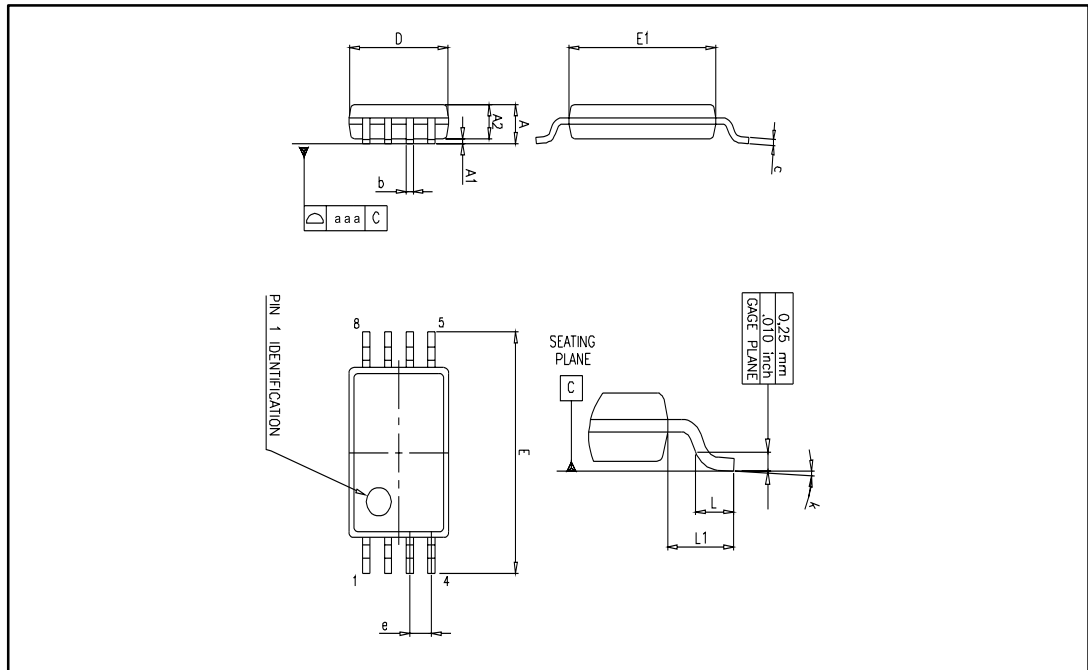

Table 5: TSSOP8 mechanical data

Ref.	Dimensions					
	Millimeters			Inches		
	Min.	Typ.	Max.	Min.	Typ.	Max.
A			1.2			0.047
A1	0.05		0.15	0.002		0.006
A2	0.80	1.00	1.05	0.031	0.039	0.041
b	0.19		0.30	0.007		0.012
c	0.09		0.20	0.004		0.008
D	2.90	3.00	3.10	0.114	0.118	0.122
E	6.20	6.40	6.60	0.244	0.252	0.260
E1	4.30	4.40	4.50	0.169	0.173	0.177
e		0.65			0.0256	
k	0°		8°	0°		8°
L	0.45	0.60	0.75	0.018	0.024	0.030
L1		1			0.039	
aaa		0.1			0.004	

9 Ordering information

Table 6: Order codes

Order code	Temperature range	Package	Packing	Marking
TL082ID	-40 °C to 105 °C	SO8	Tube or tape and reel	082I
TL082IDT		TSSOP8	Tape and reel	
TL082IPT				
TL082CD	0 °C to 70 °C	SO8	Tube or tape and reel	082C
TL082CDT		TSSOP8	Tape and reel	
TL082CPT				
TL082ACDT		SO8		082AC
TL082BCDT				082BC
TL082IYDT ⁽¹⁾	-40 °C to 105 °C	SO8 (automotive grade)	Tube or tape and reel	082IY
TL082AIYDT ⁽¹⁾				82AIY
TL082BIYDT ⁽¹⁾				82BIY

Notes:

⁽¹⁾Qualified and characterized according to AEC Q100 and Q003 or equivalent, advanced screening according to AEC Q001 and Q 002 or equivalent.

10 Revision history

Table 7: Document revision history

Date	Revision	Changes
02-Apr-2001	1	Initial release.
2002-2003	2-7	Internal revisions.
30-Apr-2004	8	Format update.
06-Mar-2007	9	Added ESD information in Table 1 on page 4. Expanded order codes table and added automotive grade order codes. See Table 7 on page 16. Added Table 2: Operating conditions on page 4. Updated package information to make it compliant with the latest JEDEC standards.
12-Jun-2008	10	Removed information concerning military temperature range (TL082M*, TL082AM*, TL082BM*).
10-Jun-2016	11	Removed DIP8 package and all obsolete order codes Updated document layout <i>Table 4</i> : added L1 dimension <i>Figure 24</i> : removed silhouette and added package outline

IMPORTANT NOTICE – PLEASE READ CAREFULLY

STMicroelectronics NV and its subsidiaries ("ST") reserve the right to make changes, corrections, enhancements, modifications, and improvements to ST products and/or to this document at any time without notice. Purchasers should obtain the latest relevant information on ST products before placing orders. ST products are sold pursuant to ST's terms and conditions of sale in place at the time of order acknowledgement.

Purchasers are solely responsible for the choice, selection, and use of ST products and ST assumes no liability for application assistance or the design of Purchasers' products.

No license, express or implied, to any intellectual property right is granted by ST herein.

Resale of ST products with provisions different from the information set forth herein shall void any warranty granted by ST for such product.

ST and the ST logo are trademarks of ST. All other product or service names are the property of their respective owners.

Information in this document supersedes and replaces information previously supplied in any prior versions of this document.

© 2016 STMicroelectronics – All rights reserved

Looking for pricing, stock, or lifecycle information?

Click below to explore more details on WIN SOURCE:

- ⊖ [View TL082BCDT on WIN SOURCE](#)
- ⊖ [STMicroelectronics Information](#)

Optimize Your Supply Chain with WIN SOURCE Solutions

- ✓ Global Sourcing Solution
- ✓ Obsolete Management
- ✓ Cost Control Management
- ✓ Shortage Management
- ✓ Alternative Solution
- ✓ Excess Inventory Management