



**THE DATASHEET OF
TJA1082TT,118**





TJA1082

FlexRay node transceiver

Rev. 6 — 28 November 2012

Product data sheet

1. General description

The TJA1082 FlexRay node transceiver is compliant with the FlexRay electrical physical layer specification V2.1 Rev. B (see [Ref. 1](#)). In addition, it incorporates features and parameters included in V3.0.1 (see [Ref. 2](#) and [Section 14](#)). It is primarily intended for communication systems operating at between 2.5 Mbit/s and 10 Mbit/s, and provides an advanced interface between the protocol controller and the physical bus in a FlexRay network. The TJA1082 offers an optimized solution for Electronic Control Unit (ECU) applications that do not need enhanced power management and are typically switched by the ignition or activated by a dedicated wake-up line.

The TJA1082 provides a differential transmit capability to the network and a differential receive capability to the FlexRay controller. It offers excellent ElectroMagnetic Compatibility (EMC) performance as well as high ElectroStatic Discharge (ESD) protection.

The TJA1082 actively monitors system performance using dedicated error and status information (readable by any microcontroller), as well as internal voltage and temperature monitoring.

2. Features and benefits

2.1 Optimized for time triggered communication systems

- Compliant with Electrical Physical Layer specification 2.1 Rev. B
- Automotive product qualification in accordance with AEC-Q100 (Grade 1)
- Data transfer at 2.5 Mbit/s, 5 Mbit/s and 10 Mbit/s
- Supports 60 ns minimum bit time at 400 mV differential voltage
- Very low ElectroMagnetic Emission (EME) to support unshielded cable
- Differential receiver with high common-mode range for excellent ElectroMagnetic Immunity (EMI)
- Auto I/O level adaptation to host controller supply voltage V_{IO}
- Can be used in 14 V and 42 V powered systems
- Instant shut-down interface (via BGE pin)

2.2 Low power management

- Very low current consumption in Standby mode
- Remote wake-up via a wake-up pattern or dedicated FlexRay data frames on the bus lines



2.3 Diagnosis and robustness

- Enhanced supply voltage monitoring for V_{CC} and V_{IO}
- Two error diagnosis modes:
 - ◆ Status register readout via the Serial Peripheral Interface (SPI)
 - ◆ Simple error indication via pin ERRN
- Overtemperature detection
- Short-circuit detection on bus lines
- Power-on flag
- Clamping diagnosis for pins TXEN and BGE
- Bus pins protected against ± 8 kV ESD pulses (according to IEC61000-4-2 and HBM)
- Bus pins protected against transients in automotive environment (according to ISO 7637 class C)
- Bus pins short-circuit proof to battery voltage (14 V and 42 V) and ground
- Maximum differential voltage between pins BP or BM and any other pin of ± 60 V
- Bus lines remain passive when the transceiver is not powered
- No reverse currents from the digital input pins to V_{IO} or V_{CC} when the transceiver is not powered

2.4 FlexRay conformance classes

- Bus driver - bus guardian interface
- Bus driver logic level adaptation

3. Ordering information

Table 1. Ordering information

Type number	Package		Version
	Name	Description	
TJA1082TT	TSSOP14	plastic thin shrink small outline package; 14 leads; body width 4.4 mm	SOT402-1

4. Block diagram

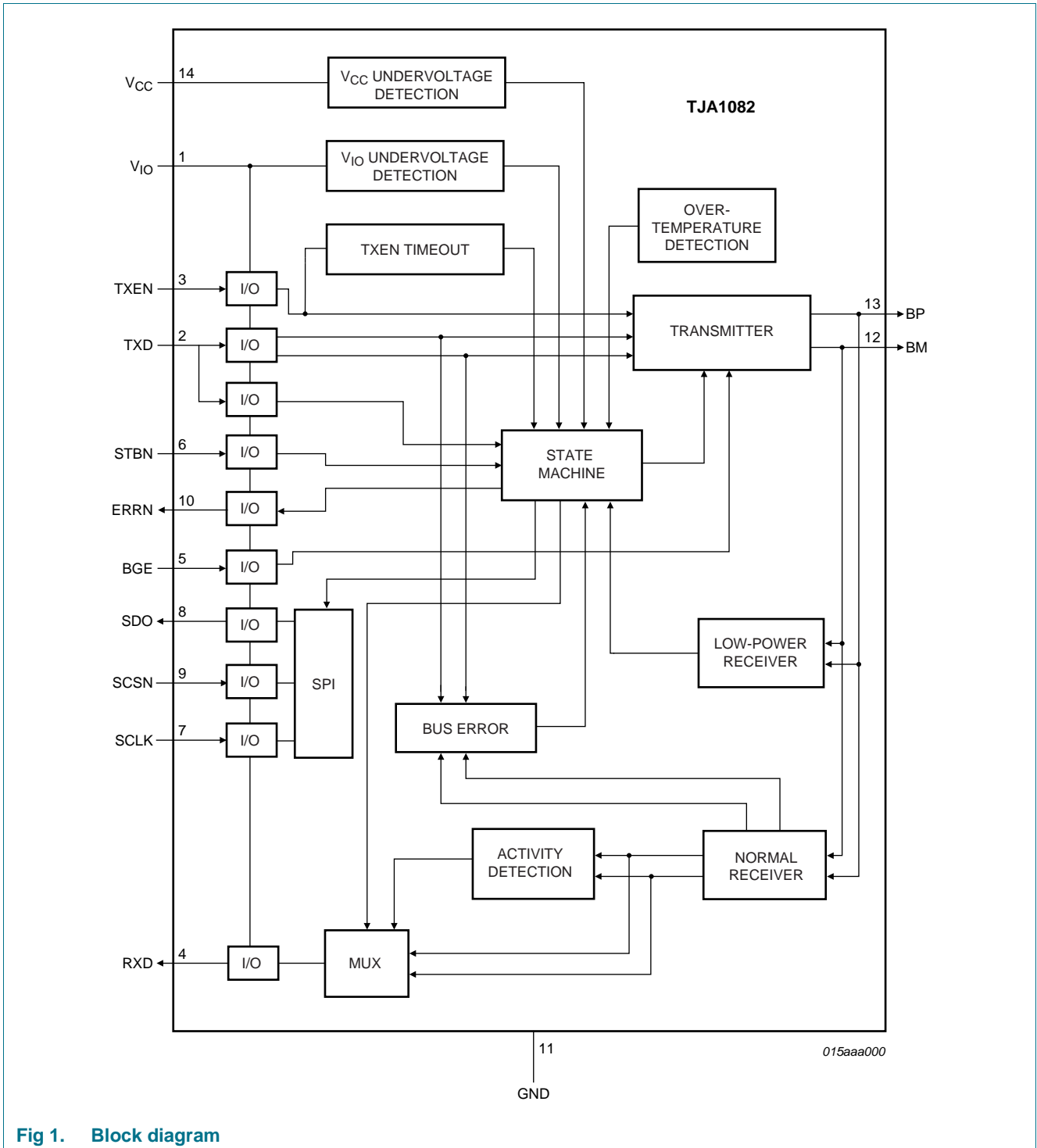
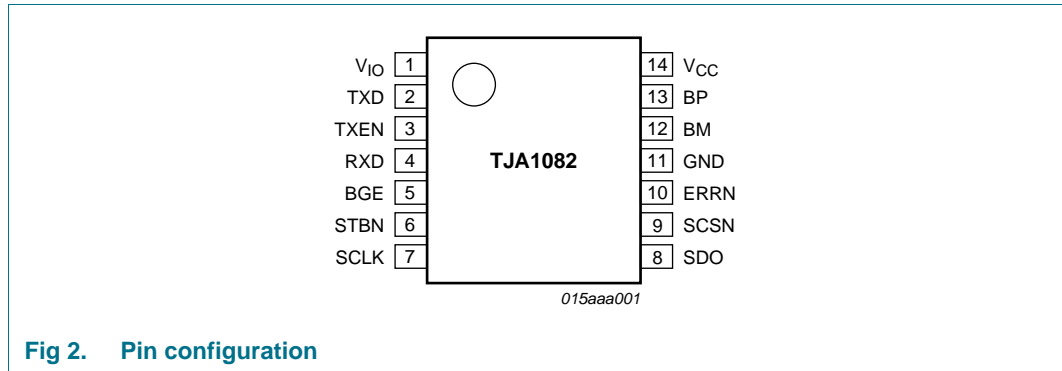

Fig 1. Block diagram

5. Pinning information

5.1 Pinning



5.2 Pin description

Table 2. Pin description

Symbol	Pin	Type	Description
V _{IO}	1	P	supply voltage for V _{IO} voltage level adaptation
TXD	2	I	transmit data input; internal pull-down
TXEN	3	I	transmitter enable input; when HIGH transmitter disabled; internal pull-up
RXD	4	O	receive data output
BGE	5	I	bus guardian enable input; when LOW transmitter disabled; internal pull-down
STBN	6	I	mode control input; transceiver in Normal mode when HIGH; internal pull-down
SCLK	7	I	SPI clock signal; internal pull-up
SDO	8	O	SPI data output
SCSN	9	I	SPI chip select input; internal pull-up/pull-down
ERRN	10	O	error diagnosis output and wake-up indication
GND	11	P	ground
BM	12	I/O	bus line minus
BP	13	I/O	bus line plus
V _{CC}	14	P	supply voltage (+5 V)

6. Functional description

6.1 Power modes

The TJA1082 features three power modes: Normal, Standby and Power-off. Normal and Standby modes can be selected via the STBN input (HIGH for Normal mode) once the transceiver has been powered up. See [Table 3](#) for a detailed description of pin signaling in the three power modes.

Table 3. Pin signalling in the different power modes

Mode	STBN	UV at V _{Io}	UV at V _{CC}	ERRN		RXD		SDO	Biasing BP, BM	UV-det	Transmitter	Low-power receiver
				LOW	HIGH	LOW	HIGH					
Normal	HIGH	no	no	error flag set	error flag reset	bus DATA_0	bus DATA_1 or idle	high-impedance (in simple error indication mode) or enabled (in SPI mode)	V _{CC} / 2	enabled	enabled	enabled ^[1]
Standby	LOW	no	no	wake flag set	wake flag reset	wake flag set	wake flag reset	high-impedance	GND		disabled	enabled ^[2]
	LOW	no	yes ^[3]	wake flag set ^[4]	wake flag reset ^[4]	wake flag set ^[4]	wake flag reset ^[4]					disabled
	HIGH	no	yes ^[3]	error flag set	error flag reset	wake flag set ^[4]	wake flag reset ^[4]					
	X	yes ^[5]	no	LOW		LOW						enabled ^[2]
	X	yes ^[5]	yes ^[3]	LOW		LOW						disabled
Power-off ^[6]	X	X ^[5]	yes	high-impedance		HIGH			GND ^[7]	disabled		disabled

- [1] The wake flag is set if a valid wake-up event is detected while switching to Standby mode.
- [2] The wake flag is set if a valid wake-up event is detected.
- [3] $V_{uvd}(V_{CC}) > V_{CC} > V_{th(det)POR}$.
- [4] Pins ERRN and RXD reflect the state of the wake flag prior to the V_{CC} undervoltage event.
- [5] The internal signals at pins STBN, BGE and TXD are set LOW; the internal signals at pins TXEN, SCLK and SCSN are set HIGH.
- [6] $V_{CC} < V_{th(rec)POR}$ at power-up and $V_{CC} < V_{th(det)POR}$ at power-down (see [Figure 6](#) and [Figure 7](#)).
- [7] Except when V_{CC} = 0; in this case BP and BM are floating.

6.1.1 Normal mode

In Normal mode, the transceiver transmits and receives data via the bus lines BP and BM. The transmitter and the normal receiver are enabled, along with the undervoltage detection function. The timing diagram for Normal mode is illustrated in [Figure 3](#).

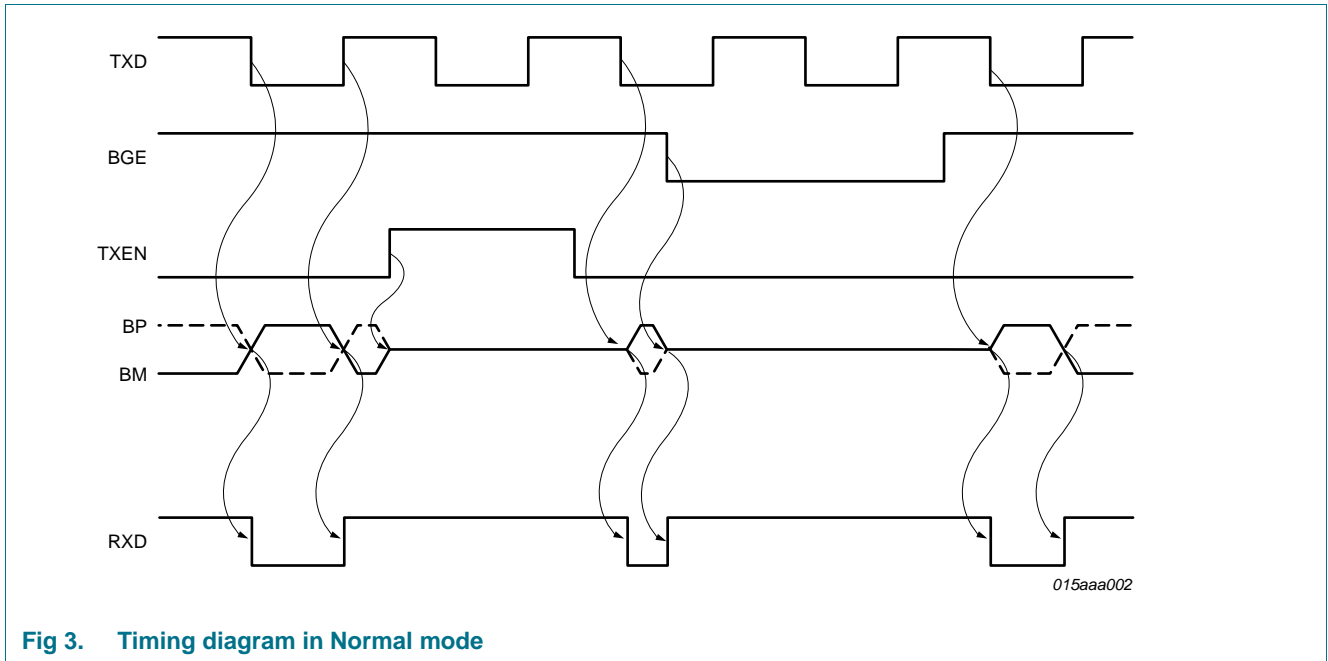

Fig 3. Timing diagram in Normal mode

Table 4 describes the behavior of the transmitter in Normal mode, when the temperature flag (TEMP HIGH) is not set and with no time-out on pin TXEN. Transmitter behavior is illustrated in Figure 14.

Table 4. Transmitter operation in Normal mode

BGE	TXEN	TXD	Bus state	Transmitter
L	X	X	idle	transmitter is disabled
X	H	X	idle	transmitter is disabled
H	L	H	DATA_1	transmitter is enabled; the bus lines are actively driven; BP is driven HIGH and BM is driven LOW
H	L	L	DATA_0	transmitter is enabled; the bus lines are actively driven; BP is driven LOW and BM is driven HIGH

The transmitter is activated during the first LOW level on pin TXD while pin BGE is HIGH and pin TXEN is LOW.

In Normal mode, the normal receiver output is connected directly to pin RXD (see Table 5). Receiver behavior is illustrated in Figure 15.

Table 5. Behavior of normal receiver in Normal mode

Bus state	RXD
DATA_0	L
DATA_1	H
idle	H

When V_{IO} and V_{CC} are within their operating ranges, pin ERRN indicates the status of the error flag. See Section 6.8 for a detailed description of error signalling in Normal mode.

6.1.1.1 Bus activity and idle detection

In Normal mode, bus activity and bus idle are detected as follows:

- Bus activity is detected when the absolute differential voltage on the bus lines is higher than $|V_{i(dif)det(act)}|$ for $t_{det(act)(bus)}$:
 - If the differential voltage on the bus lines is lower than $V_{L(dif)}$ after bus activity has been detected, pin RXD switches LOW.
 - If the differential voltage on the bus lines is higher than $V_{H(dif)}$ after bus activity has been detected, pin RXD remains HIGH.
- Bus idle is detected when the absolute differential voltage on the bus lines is lower than $|V_{i(dif)det(act)}|$ for $t_{det(idle)(bus)}$. This results in pin RXD being switched HIGH or staying HIGH.

6.1.2 Standby mode

Standby mode is a low-power mode featuring very low current consumption. In Standby mode, the transceiver is unable to transmit or receive data since both the transmitter and the normal receiver are switched off. The low-power receiver is activated to monitor the bus for wake-up activity, provided an undervoltage has not been detected on pin V_{CC} .

The low-power receiver is deactivated if an undervoltage is detected on pin V_{CC} - with the result that the wake flag is not set if a wake-up pattern or dedicated data frame is received.

Pins ERRN and RXD indicate the status of the wake flag when V_{IO} and V_{CC} are within their operating ranges. See [Table 3](#) for a description of pins ERRN and RXD when an undervoltage is detected on pin V_{IO} or pin V_{CC} .

The status register cannot be read via the SPI interface if an undervoltage is detected on pin V_{IO} .

The BGE input has no effect in Standby mode.

6.1.3 Power-off mode

The transmitter and the two receivers (normal and low-power) are deactivated in Power-off mode. As a result, the wake flag is not set if a wake-up pattern or dedicated data frame is received. If the voltage at V_{CC} rises above $V_{th(rec)POR}$, the transceiver switches to Standby mode and the digital section is reset. If V_{CC} subsequently drops below $V_{th(det)POR}$, the transceiver reverts to Power-off mode (see [Section 6.2](#)).

The status register cannot be read via the SPI interface in Power-off mode.

6.1.4 State transitions

[Figure 4](#) shows the TJA1082 state transition diagram. The timing diagram for the ERRN indication signal during transitions between Normal and Standby modes, when the error flag is set and the wake flag is not set, is illustrated in [Figure 5](#) and described in [Table 6](#).

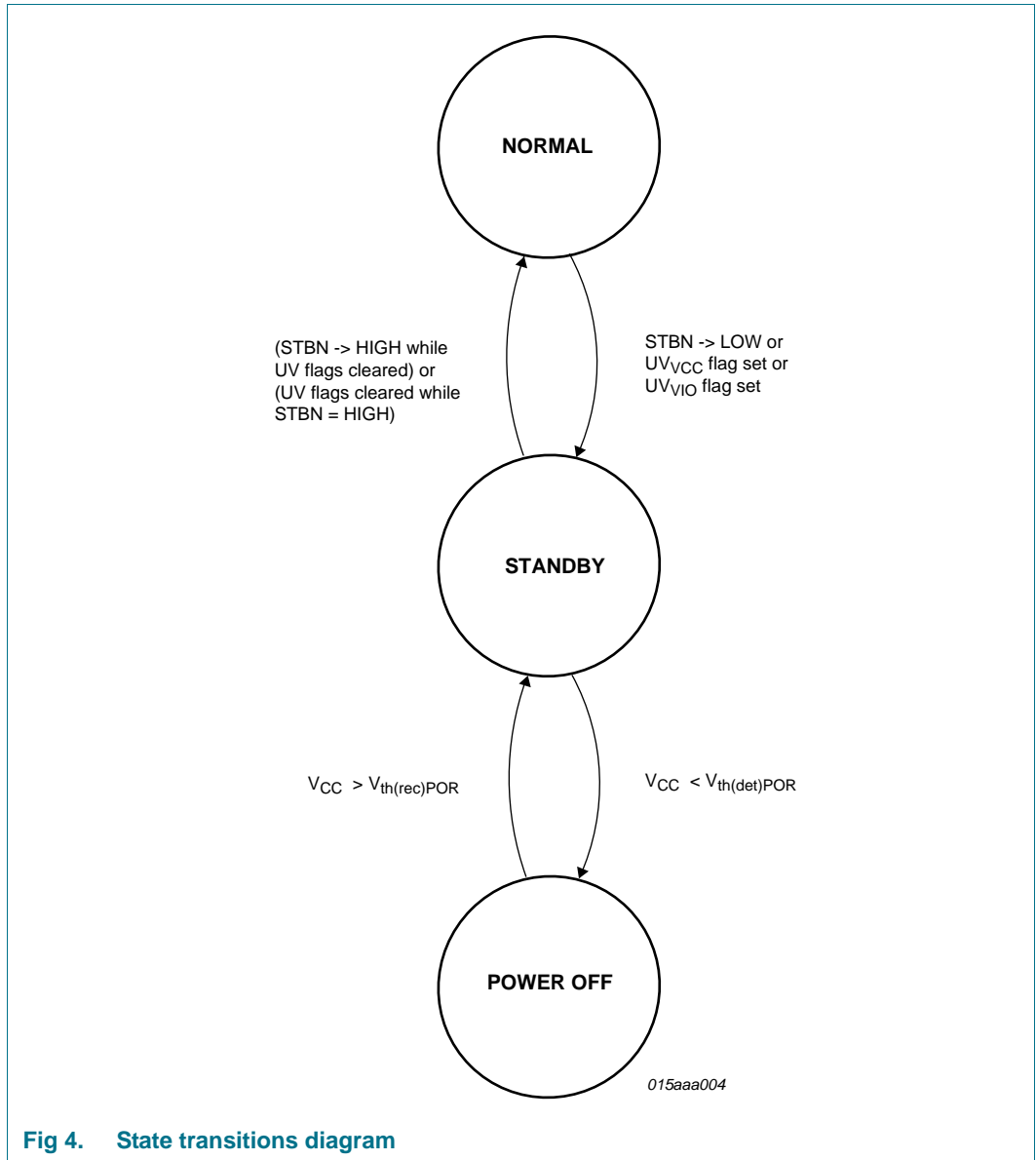

Fig 4. State transitions diagram

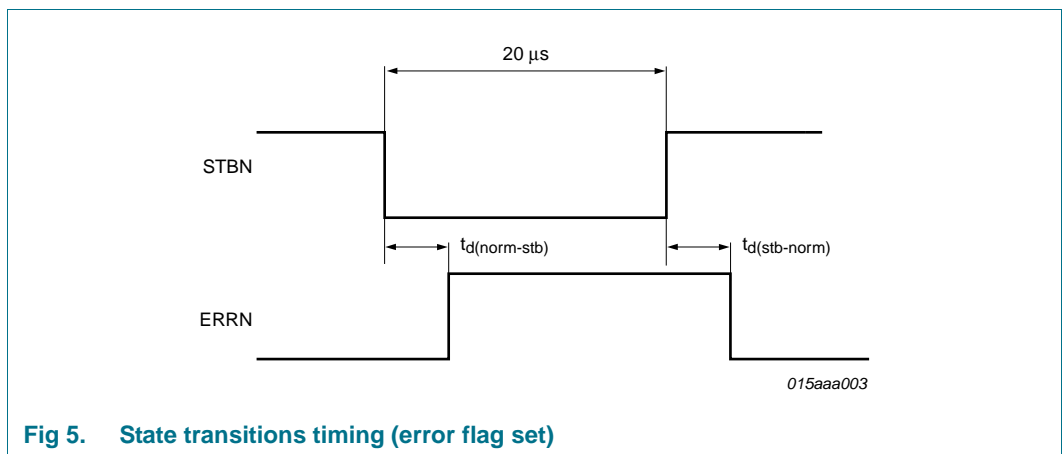

Fig 5. State transitions timing (error flag set)

Table 6. State transitions

→ indicates the action that initiates a transaction; 1 → and 2 → are the consequences of a transaction.

Transition	UVV _{IO} flag ^[1]	UVV _{CC} flag ^[1]	wake flag ^[1]	PWON flag ^[1]	STBN	VCC level
Normal to Standby	cleared	cleared	cleared	cleared	→ L	$V_{CC} > V_{uvd}(V_{CC})$
	→ set	cleared	cleared	cleared	H	$V_{CC} > V_{uvd}(V_{CC})$
	cleared	→ set	cleared	cleared	H	$V_{uvd}(V_{CC}) > V_{CC} > V_{th(det)POR}$
Standby to Normal	cleared	cleared	1 → cleared	2 → cleared	→ H	$V_{CC} > V_{uvd}(V_{CC})$
	→ cleared	cleared	1 → cleared	2 → cleared	H	$V_{CC} > V_{uvd}(V_{CC})$
	cleared	→ cleared	1 → cleared	2 → cleared	H	$V_{uvd}(V_{CC}) > V_{CC} > V_{th(det)POR}$
Standby to Power-off	X	set	X	X	X	→ $V_{CC} < V_{th(det)POR}$
Power-off to Standby	X	set	X	1 → set	X	→ $V_{CC} > V_{th(rec)POR}$

[1] See [Table 7](#) for set and reset conditions of all flags.

6.2 Power-up and power-down behavior

6.2.1 Power-up

The TJA1082 has two supply pins: V_{CC} (+5 V) and V_{IO} (for the voltage level adaptation). The ramp up of the different power supplies can vary, depending on the state or value of a number of signals and parameters. The power-up behavior of the TJA1082 is not affected by the sequence in which power is supplied to these pins or by the voltage ramp up.

As an example, [Figure 6](#) shows one possible power supply ramp-up scenario. The digital section of the TJA1082 is supplied by V_{CC} . The voltage on pin V_{CC} ramps up before the voltage on pin V_{IO} . As long as the voltage on V_{CC} remains below the power-on reset recovery threshold, $V_{th(rec)POR}$, the internal state machine is not active and the transceiver is totally passive, remaining in Power-off mode. As soon as the voltage crosses the $V_{th(rec)POR}$ threshold, the internal state machine starts running, setting the PWON flag and switching the TJA1082 to Standby mode. This initializes the V_{CC} and V_{IO} under-voltage flags to the set state (since both V_{CC} and V_{IO} are actually in undervoltage state just after power-on).

Once both V_{IO} and V_{CC} have reached their operating ranges, the under-voltage flags are reset. The operating mode is then determined by the level on STBN (the TJA1082 switches to Normal mode if STBN is HIGH and remains in Standby mode if STBN is LOW), provided V_{IO} and V_{CC} are above their respective undervoltage recovery levels ($V_{uvr}(V_{IO})$ and $V_{uvr}(V_{CC})$).

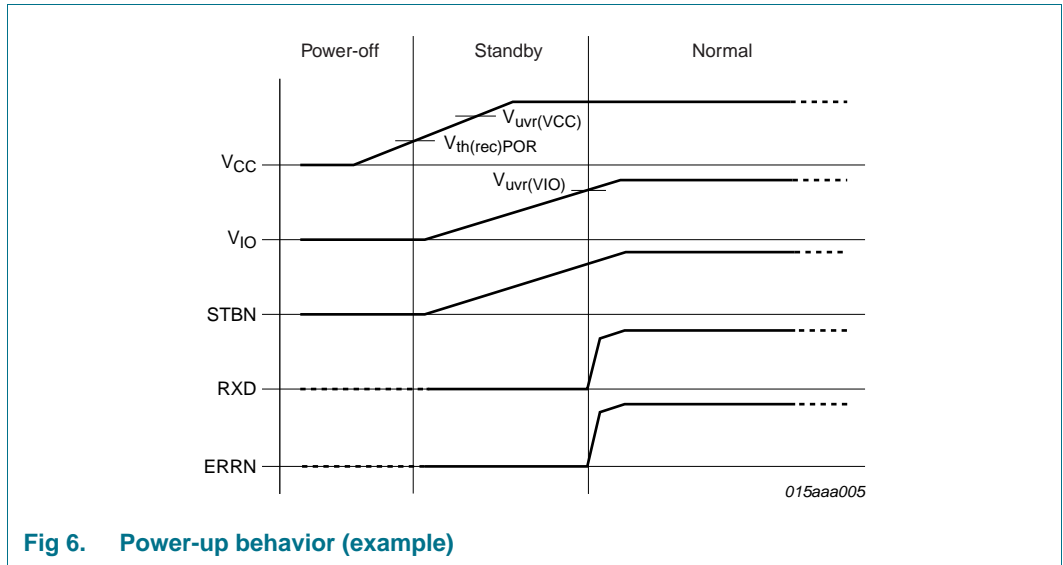

Fig 6. Power-up behavior (example)

6.2.2 Power-down

The behavior of the TJA1082 during power-down is illustrated in [Figure 7](#).

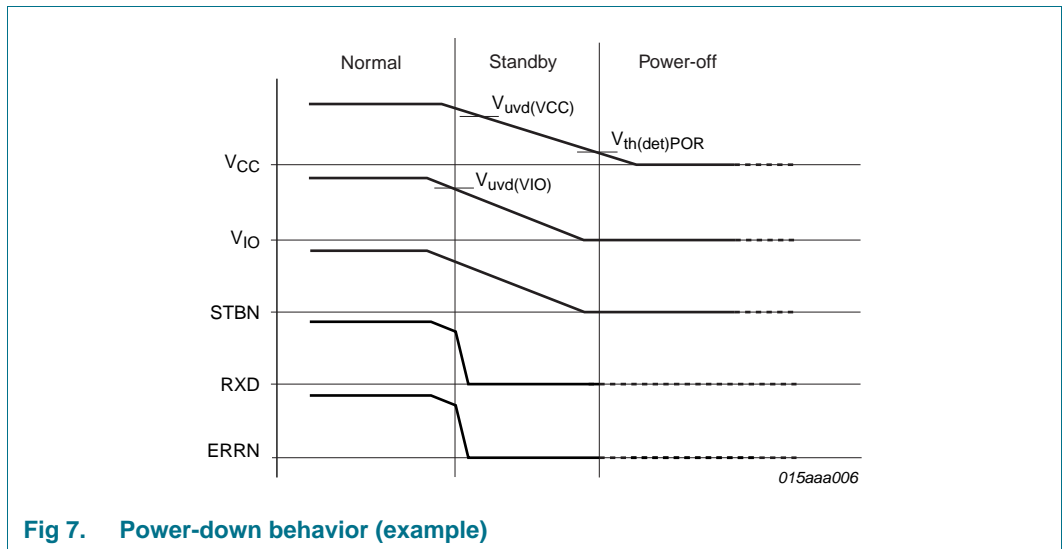

Fig 7. Power-down behavior (example)

6.3 Remote wake-up

6.3.1 Bus wake-up via wake-up pattern

A valid remote wake-up event occurs when a wake-up pattern is received. A wake-up pattern consists of at least two consecutive wake-up symbols. A wake-up symbol consists of a DATA_0 phase lasting longer than $t_{det(wake)DATA_0}$, followed by an idle phase lasting longer than $t_{det(wake)idle}$, provided both wake-up symbols occur within a time span of $t_{det(wake)tot}$ (see [Figure 8](#)). The transceiver also wakes up if the idle phases are replaced by DATA_1 phases.

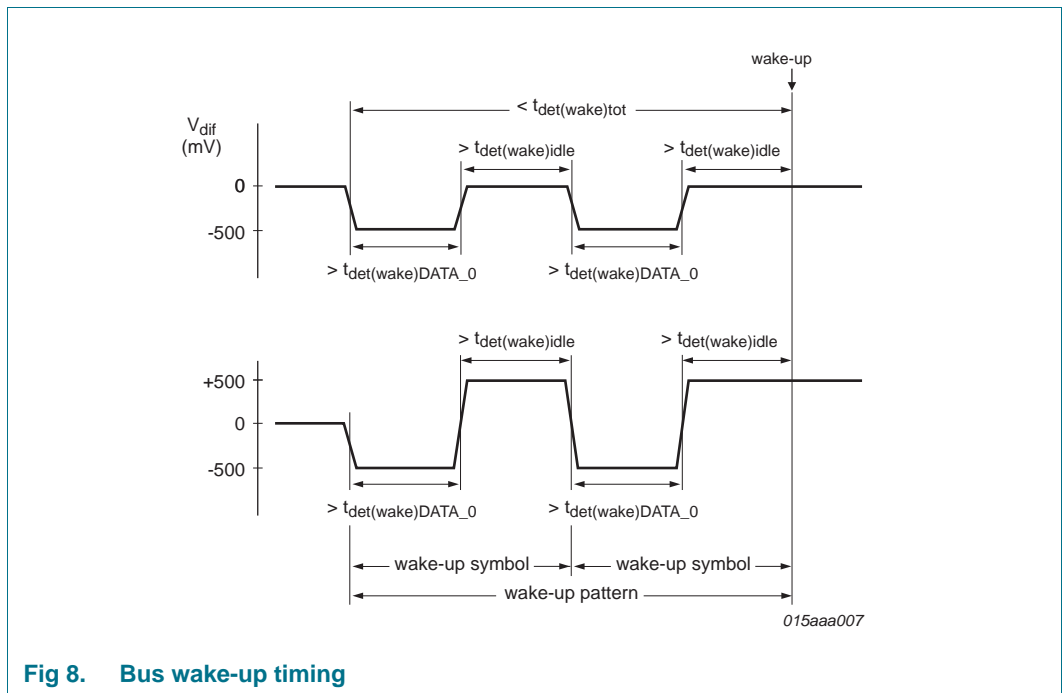

Fig 8. Bus wake-up timing

The wake-up mechanism of the TJA1082 follows the state transition diagram shown in [Figure 9](#). See [Ref. 1](#) for more details of the wake-up mechanism.

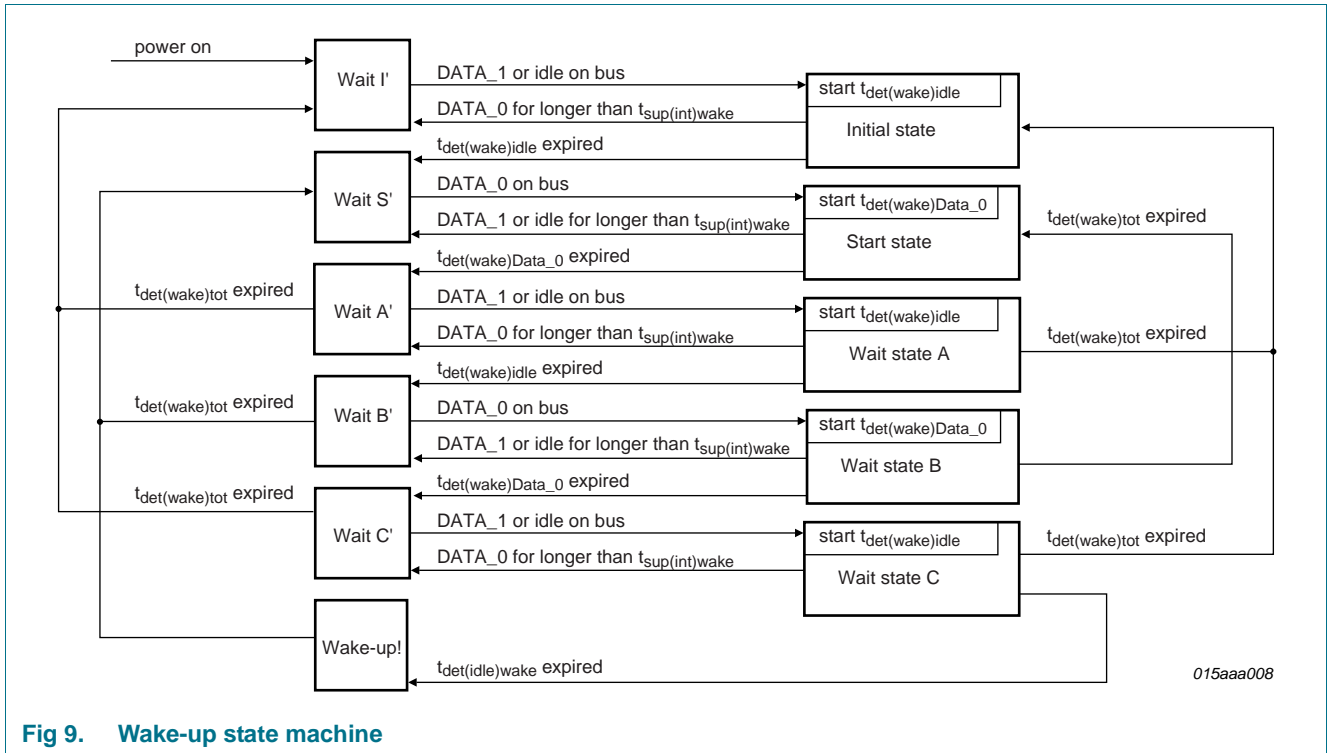

Fig 9. Wake-up state machine

6.3.2 Bus wake-up via dedicated FlexRay data frame

The TJA1082 wake flag is set when a dedicated data frame emulating a valid wake-up pattern, as shown in [Figure 10](#), is received.

The DATA_0 and DATA_1 phases of the emulated wake-up symbol are interrupted by the Byte Start Sequence (BSS) preceding each byte in the data frame. With a data rate of 10 Mbit/s, the interruption has a maximum duration of 130 ns and does not prevent the transceiver from recognizing the wake-up pattern in the payload.

For longer interruptions at lower data rates (5 Mbit/s and 2.5 Mbit/s), the wake-up pattern should be used (see [Section 6.3.1](#)).

The wake flag is not set if an invalid wake-up pattern is received. See [Ref. 1](#) for more details on invalid wake-up patterns.

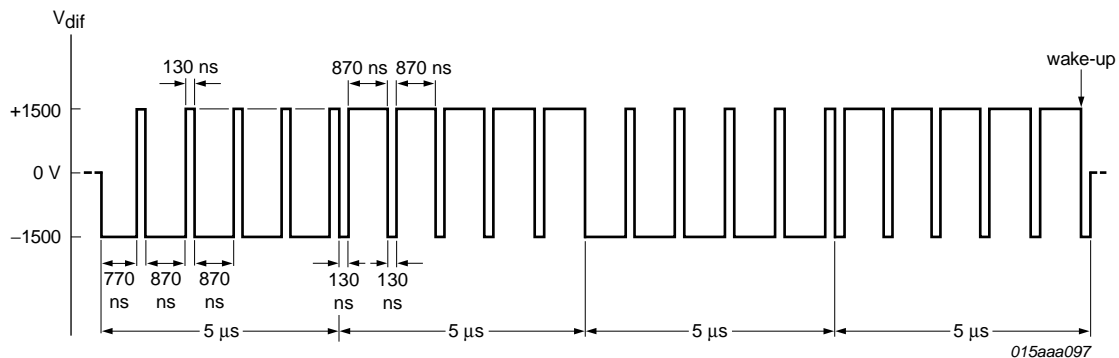

The duration of each interruption is 130 ns.

The transition time from DATA_0 to DATA_1 and vice versa is about 20 ns.

The TJA1082 wake-up flag is set on receipt of the following frame payload:

```
0xFF, 0xFF, 0xFF, 0xFF, 0xFF, 0x00, 0x00, 0x00, 0x00, 0x00,
0xFF, 0xFF, 0xFF, 0xFF, 0xFF, 0x00, 0x00, 0x00, 0x00, 0x00,
0xFF, 0xFF, 0xFF, 0xFF, 0xFF, 0x00, 0x00, 0x00, 0x00, 0x00,
0xFF, 0xFF, 0xFF, 0xFF, 0xFF
```

Fig 10. Minimum bus pattern for bus wake-up via dedicated FlexRay data frame

6.4 Bus error detection

The TJA1082 detects the following bus errors during transmission:

- Short-circuit BP to BM at the ECU connector or on the bus
- Short-circuit BP to GND at the ECU connector or on the bus
- Short-circuit BM to GND at the ECU connector or on the bus
- Short-circuit BP to V_{CC} at the ECU connector or on the bus
- Short-circuit BM to V_{CC} at the ECU connector or on the bus

The bus error flag is not set when a wake-up pattern or a FlexRay Collision Avoidance Symbol (CAS) is being transmitted or received.

6.5 Fail silent behavior

Three mechanisms guarantee the 'fail silent' behavior of the TJA1082:

- The TXEN Clamped flag is set if pin TXEN goes LOW for longer than $t_{detCL(TXEN)}$ in Normal mode; the transmitter is disabled.
- The BGE Clamped flag is set if pin BGE goes HIGH for longer than $t_{detCL(BGE)}$ in Normal mode; no action is taken.
- If a loss-of-ground occurs at the transceiver, resulting in the TJA1082 switching to Power-off mode, no current flows out of the digital input pins (TXD, TXEN, BGE, STBN, SCLK, SCSN); see [Table 3](#) for details of the behavior of the bus pins.

6.6 TJA1082 flags

The TJA1082 has 11 status/error flags. These are described in [Table 7](#).

Table 7. TJA1082 flags and set/reset conditions

Flag name	Flag type	Flag description	Set condition	Reset condition ^[1]	Consequence of flag set
bus wake	status flag	indicates if a wake-up event has occurred	wake-up event on bus in Standby mode ^[2]	transition to Normal mode	RXD → LOW; ERRN → LOW ^[3]
Normal mode	status flag	indicates if the transceiver is in Normal mode	entering Normal mode	leaving Normal mode	-
transmitter enabled	status flag	indicates the transmitter status	transmitter enabled ^[4]	transmitter disabled	-
BGE clamped	status flag	indicates if pin BGE is clamped	BGE HIGH for longer than $t_{detCL}(BGE)$ ^[5]	BGE LOW ^[5]	-
PWON	status flag	indicates when the digital section is initialized	$V_{CC} > V_{th(rec)POR}$	transition to Normal mode	-
bus error	error flag	indicates if a bus error has been detected	bus error detected ^[5]	no bus error detected or positive edge on TXEN ^[5]	ERRN → LOW ^[6]
TEMP HIGH	error flag	indicates if the max. junction temperature has been reached	$T_{vj} > T_{j(dis)(high)}$ ^[5]	TXEN = HIGH while $T_{vj} < T_{j(dis)(high)}$ ^[5]	ERRN → LOW ^[6] ; transmitter disabled
TXEN clamped	error flag	indicates if pin TXEN is clamped	TXEN LOW for longer than $t_{detCL}(TXEN)$ ^[5]	TXEN = HIGH ^[5]	ERRN → LOW ^[6] ; transmitter disabled
UVV _{CC}	error flag	indicates if there is an undervoltage at pin V _{CC}	$V_{CC} < V_{uvd}(V_{CC})$ for longer than $t_{det}(uv)(V_{CC})$	$V_{CC} > V_{uvr}(V_{CC})$ for longer than $t_{rec}(uv)(V_{CC})$	ERRN → LOW ^[6] ; entering Standby mode
UVV _{IO}	error flag	indicates if there is an undervoltage at pin V _{IO}	$V_{IO} < V_{uvd}(V_{IO})$ for longer than $t_{det}(uv)(V_{IO})$	$V_{IO} > V_{uvr}(V_{IO})$ for longer than $t_{rec}(uv)(V_{IO})$	ERRN → LOW ^[6] ; entering Standby mode
SPI error	error flag	indicates if an SPI error has occurred	SPI error detected ^[8]	falling edge on SCSN	ERRN → LOW ^[7] ; SDO goes to a high impedance state

[1] All flags, with the exception of the PWON flag, are reset after a power-on reset.

[2] If an undervoltage has not been detected on pin V_{CC}.

[3] If STBN = LOW.

[4] If BGE = HIGH, the Normal mode flag is set, the TEMP HIGH flag is not set and the TXEN clamped flag is not set.

[5] Flag can only be set or reset in Normal mode or on leaving Normal mode.

[6] If STBN = HIGH.

[7] If STBN = HIGH in SPI mode

[8] The SPI error flag is set when:

- more than 16 falling edges occur on pin SCLK while pin SCSN = LOW
- less than 16 falling edges occur on pin SCLK while pin SCSN = LOW.

6.7 TJA1082 status register

The TJA1082 contains a 16-bit status register, of which bits S0 to S4 reflect the state of the status flags, bits S5 to S10 reflect the state of the error flags and bit S15 is a parity bit. All flags can be individually read out on pin SDO via a 16-bit SPI interface when the transceiver is configured in SPI mode. The status register bits are described in [Table 8](#).

Table 8. TJA1082 status register

Status bit	Flag name	Set condition	Reset condition
S0	bus wake	bus wake flag set	bus wake flag cleared
S1	Normal mode	Normal mode flag set	Normal mode flag cleared
S2	transmitter enabled	transmitter enabled flag set	transmitter enabled flag cleared
S3	BGE clamped	BGE clamped flag set	BGE clamped flag cleared
S4	PWON	PWON flag set	PWON flag cleared and successful readout ^[1]
S5	bus error	bus error flag set	bus error flag cleared and successful readout ^[1]
S6	TEMP HIGH	TEMP HIGH flag set	TEMP HIGH flag cleared and successful readout ^[1]
S7	TXEN clamped	TXEN clamped flag set	TXEN clamped flag cleared and successful readout ^[1]
S8	UVV _{CC}	UVV _{CC} flag set	UVV _{CC} flag cleared and successful readout ^[1]
S9	UVV _{IO}	UVV _{IO} flag set	UVV _{IO} flag cleared and successful readout ^[1]
S10	SPI error	SPI error flag set	SPI error flag cleared and successful readout ^[1]
S11	reserved	always LOW	
S12	reserved	always HIGH	
S13	reserved	always LOW	
S14	reserved	always HIGH	
S15	parity bit	odd parity of status bits	even parity of status bits

[1] Also cleared during Power-off.

6.8 Error signalling

The TJA1082 provides two modes for error indication:

- SPI mode (default mode)
- Simple error indication mode

SPI mode is active on power-up.

To switch to simple error indication mode, SCSN has to be held LOW (connected to GND) and SCLK held HIGH (connected to V_{IO}) for longer than $t_{\text{det(L)}(\text{SCLK})}$ (provided a V_{IO} undervoltage has not occurred).

When the TJA1082 is in simple error indication mode, a rising edge on SCSN initiates a transition to SPI mode (provided a V_{IO} undervoltage has not occurred).

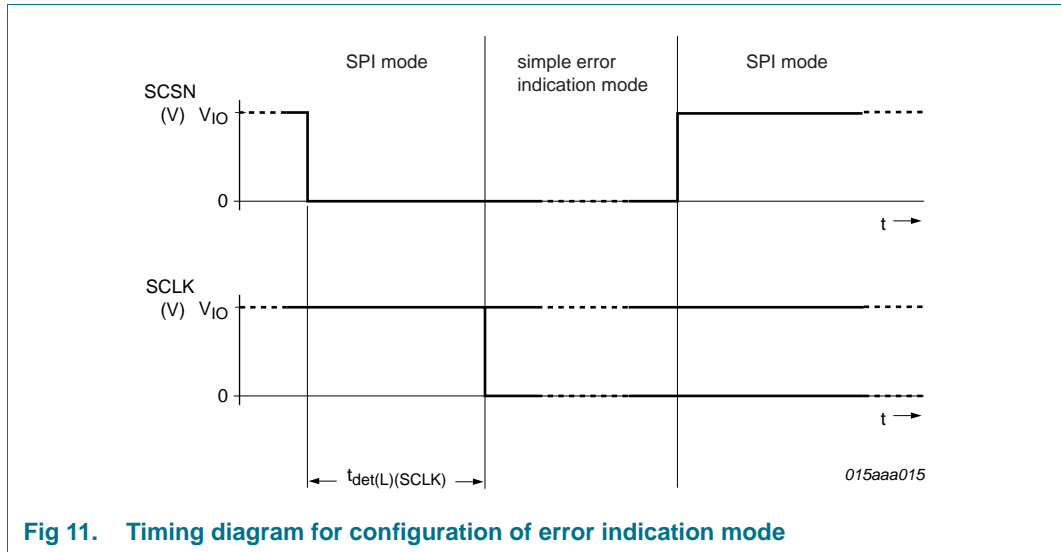

Fig 11. Timing diagram for configuration of error indication mode

If a V_{IO} undervoltage condition is detected, it is not possible to switch between SPI mode and simple error indication mode.

6.8.1 SPI mode

The error flag information in the status register is latched in SPI mode. This means that the status bit is reset once the status register has been completely read (provided the corresponding error flag has been reset). If an error condition is detected in Normal mode, pin ERRN goes LOW (provided one of the error bits, S5-S10, is set). Pin ERRN goes HIGH again once all the error bits (S5-S10) have been reset.

6.8.2 Simple error indication mode

If an error condition is detected in Normal mode, pin ERRN goes LOW once the relevant error flag has been set. Pin ERRN goes HIGH again when all error conditions have been cleared and all flags have been reset. Error flags are not latched. It is not possible to read-out the status bits in this mode.

6.9 SPI interface

The TJA1082 includes a 16-bit SPI interface to enable a host to read the status register when the transceiver is in SPI mode (see [Section 6.8](#)).

While pin SCSN is HIGH, the SDO output is in a high-impedance state. To begin a status register readout, the host must force pin SCSN LOW. This causes the SDO pin to output a LOW level by default. The data at pin SDO is then shifted out on the rising edge of the clock signal on pin SCLK.

The status bits shifted out at SDO are active HIGH. The status bits are refreshed and pin SDO returned to a high-impedance state once the status register has been read successfully (after exactly 16 clock cycles) and SCSN has been forced HIGH again. Clock signals on SCLK are ignored while SCSN is HIGH. The timing diagram for the SPI readout is illustrated in [Figure 12](#).

The SCLK period ranges from 500 ns to 100 μ s (10 kbit/s to 2 Mbit/s).

If SCSN remains LOW for longer than 16 clock cycles, it recognized as an SPI error. When this happens, the SPI error flag is set and pin SDO goes to a high-impedance state until the next falling edge on pin SCSN.

An SPI error is also assumed if fewer than 16 clock cycles are received while SCSN is LOW. If this happens, the SPI error flag is set.

All status bits are refreshed once the status register has been successfully read.

When the transceiver is in simple error indication mode the SDO output is in a high-impedance state and pin SCSN is in pull-down mode. In SPI mode pin SCSN is in pull-up mode.

SPI readout is not possible when the transceiver has detected an undervoltage on V_{IO} .

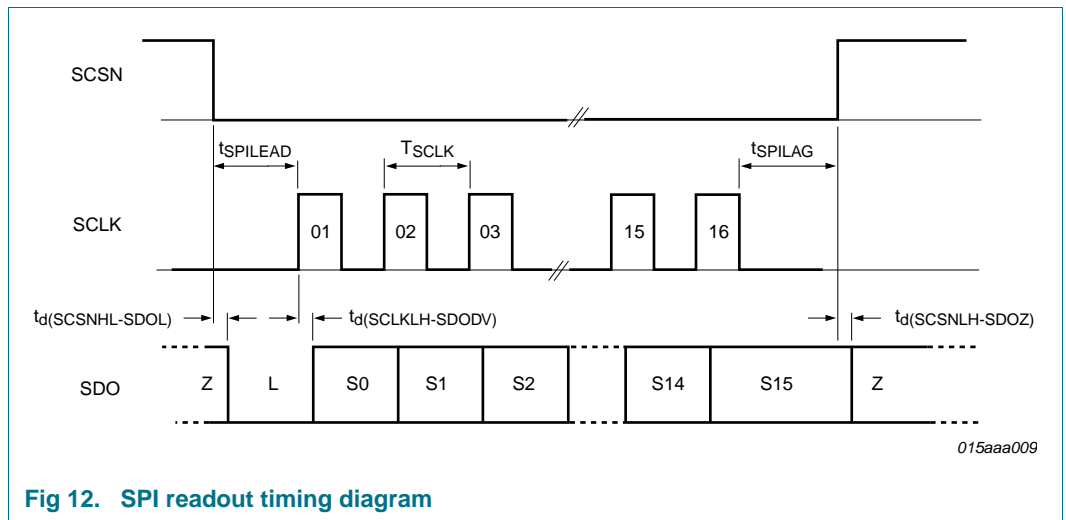

Fig 12. SPI readout timing diagram

7. Limiting values

Table 9. Limiting values

In accordance with the Absolute Maximum Rating System (IEC 60134). All voltages are referenced to GND.

Symbol	Parameter	Conditions	Min	Max	Unit
V_{CC}	supply voltage	no time limit	-0.3	+5.5	V
V_{IO}	supply voltage on pin V_{IO}	no time limit	-0.3	+5.5	V
V_{ERRN}	voltage on pin ERRN	no time limit	-0.3	$V_{IO} + 0.3$	V
V_{RXD}	voltage on pin RXD	no time limit	-0.3	$V_{IO} + 0.3$	V
V_{SDO}	voltage on pin SDO	no time limit	-0.3	$V_{IO} + 0.3$	V
V_{TXEN}	voltage on pin TXEN	no time limit	-0.3	+5.5	V
V_{TXD}	voltage on pin TXD	no time limit	-0.3	+5.5	V
V_{STBN}	voltage on pin STBN	no time limit	-0.3	+5.5	V
V_{SCSN}	voltage on pin SCSN	no time limit	-0.3	+5.5	V
V_{SCLK}	voltage on pin SCLK	no time limit	-0.3	+5.5	V
V_{BGE}	voltage on pin BGE	no time limit	-0.3	+5.5	V
V_{BP}	voltage on pin BP	no time limit (with respect to pins BM and GND)	-60	+60	V

Table 9. Limiting values ...continued

In accordance with the Absolute Maximum Rating System (IEC 60134). All voltages are referenced to GND.

Symbol	Parameter	Conditions	Min	Max	Unit	
V _{BM}	voltage on pin BM	no time limit (with respect to pins BP and GND)	-60	+60	V	
I _{I(ERRN)}	input current on pin ERRN	no time limit; V _{IO} = 0 V	-10	10	mA	
I _{I(RXD)}	input current on pin RXD	no time limit; V _{IO} = 0 V	-10	10	mA	
I _{I(SDO)}	input current on pin SDO	no time limit; V _{IO} = 0 V	-10	10	mA	
V _{trt}	transient voltage	on pins BM and BP	[1]	-100	-	V
			[2]	-	75	V
			[3]	-150	-	V
			[4]	-	100	V
T _{stg}	storage temperature		-55	+150	°C	
T _{vj}	virtual junction temperature		[5]	-40	+150	°C
V _{ESD}	electrostatic discharge voltage	IEC61000-4-2 on pins BP and BM to ground	[6]	-8.0	+8.0	kV
		HBM on pins BP and BM to ground	[7]	-8.0	+8.0	kV
		HBM on any other pin	[7]	-4.0	+4.0	kV
		MM on all pins	[8]	-200	+200	V
		CDM on all pins	[9]	-1000	+1000	V

[1] According to ISO7637, test pulse 1, class C; verified by an external test house.

[2] According to ISO7637, test pulse 2a, class C; verified by an external test house.

[3] According to ISO7637, test pulse 3a, class C; verified by an external test house.

[4] According to ISO7637, test pulse 3b, class C; verified by an external test house.

[5] In accordance with IEC 60747-1. An alternative definition of virtual junction temperature T_{vj} is: T_{vj} = T_{amb} + TD × R_{th(j-a)}, where R_{th(j-a)} is a fixed value to be used for the calculation of T_{vj}. The rating for T_{vj} limits the allowable combinations of power dissipation (P) and ambient temperature (T_{amb}).

[6] IEC61000-4-2: C = 150 pF; R = 330 Ω.

[7] HBM: C = 100 pF; R = 1.5 kΩ.

[8] MM: C = 200 pF; L = 0.75 μH; R = 10 Ω.

[9] CDM: R = 1 Ω.

8. Thermal characteristics

Table 10. Thermal characteristics

Symbol	Parameter	Conditions	Typ	Unit
R _{th(j-a)}	thermal resistance from junction to ambient	in free air	130	K/W

9. Static characteristics

Table 11. Static characteristics

All parameters are guaranteed for $V_{CC} = 4.5\text{ V to }5.25\text{ V}$; $V_{IO} = 2.6\text{ V to }5.25\text{ V}$; $T_{vj} = -40\text{ °C to }+150\text{ °C}$ and $R_{bus} = 45\ \Omega$ unless otherwise specified. All voltages are defined with respect to ground; positive currents flow into the IC.

Symbol	Parameter	Conditions	Min	Typ	Max	Unit
Pin V_{CC}						
I _{CC}	supply current	Standby mode with no undervoltage; $T_{vj} \leq 85\text{ °C}$	-	20	30	μA
		Standby mode with no undervoltage; $T_{vj} \leq 150\text{ °C}$	-	20	40	μA
		Power-off mode; $T_{vj} \leq 85\text{ °C}$	-	-	30	μA
		Power-off mode; $T_{vj} \leq 150\text{ °C}$	-	-	40	μA
		Normal mode; $V_{BGE} = 0\text{ V}$ or $V_{TXEN} = V_{IO}$	-	-	15	mA
		Normal mode; $V_{BGE} = V_{IO}$; $V_{TXEN} = 0\text{ V}$; $R_{bus} \geq 45\ \Omega$	-	-	35	mA
		Normal mode; $V_{BGE} = V_{IO}$; $V_{TXEN} = 0\text{ V}$; $R_{bus} > 10\ \text{M}\Omega$	-	-	15	mA
V _{uvd(VCC)}	undervoltage detection voltage on pin V _{CC}		4.5	-	4.729	V
V _{uvr(VCC)}	undervoltage recovery voltage on pin V _{CC}		4.52	-	4.749	V
V _{uvhys(VCC)}	undervoltage hysteresis voltage on pin V _{CC}		20	-	240	mV
V _{th(det)POR}	power-on reset detection threshold voltage		3.75	-	4.15	V
V _{th(rec)POR}	power-on reset recovery threshold voltage		3.85	-	4.25	V
V _{hys(POR)}	power-on reset hysteresis voltage		100	-	500	mV
Pin V_{IO}						
I _{IO}	supply current on pin V _{IO}	Normal mode; $V_{TXEN} = V_{IO}$; $V_{BGE} = V_{IO}$; $R_{RXD} > 10\ \text{M}\Omega$	-	-	1000	μA
		Normal mode; $V_{TXEN} = 0\text{ V}$; $V_{BGE} = V_{IO}$; $R_{RXD} > 10\ \text{M}\Omega$	-	-	1000	μA
		Standby mode with no undervoltage	-	2.2	7	μA
		Power-off mode; $V_{IO} = 5\text{ V}$	-	3	7	μA
V _{uvd(VIO)}	undervoltage detection voltage on pin V _{IO}		2.6	-	2.779	V
V _{uvr(VIO)}	undervoltage recovery voltage on pin V _{IO}		2.62	-	2.799	V
V _{uvhys(VIO)}	undervoltage hysteresis voltage on pin V _{IO}		20	-	190	mV
Pin SCSN						
V _{IH}	HIGH-level input voltage		0.7V _{IO}	-	5.5	V
V _{IL}	LOW-level input voltage		-0.3	-	0.3V _{IO}	V

Table 11. Static characteristics ...continued

All parameters are guaranteed for $V_{CC} = 4.5\text{ V}$ to 5.25 V ; $V_{IO} = 2.6\text{ V}$ to 5.25 V ; $T_{vj} = -40\text{ }^{\circ}\text{C}$ to $+150\text{ }^{\circ}\text{C}$ and $R_{bus} = 45\text{ }\Omega$ unless otherwise specified. All voltages are defined with respect to ground; positive currents flow into the IC.

Symbol	Parameter	Conditions	Min	Typ	Max	Unit
I_{IH}	HIGH-level input current	simple error indication mode; $V_{SCSN} = 0.7V_{IO}$	3	-	15	μA
I_{IL}	LOW-level input current	SPI mode; $V_{SCSN} = 0.3V_{IO}$	-15	-	-3	μA
I_r	reverse current	Power-off mode; to V_{CC} / V_{IO} ; $V_{SCSN} = 5\text{ V}$; $V_{CC} = V_{IO} = 0\text{ V}$	-5	0	+5	μA
Pin SCLK						
V_{IH}	HIGH-level input voltage		$0.7V_{IO}$	-	5.5	V
V_{IL}	LOW-level input voltage		-0.3	-	$0.3V_{IO}$	V
I_{IH}	HIGH-level input current	$V_{SCLK} = V_{IO}$	-1	0	+1	μA
I_{IL}	LOW-level input current	$V_{SCLK} = 0.3V_{IO}$	-15	-	-3	μA
I_r	reverse current	Power-off mode; to V_{CC} / V_{IO} ; $V_{SCLK} = 5\text{ V}$; $V_{CC} = V_{IO} = 0\text{ V}$	-5	0	+5	μA
Pin STBN						
V_{IH}	HIGH-level input voltage		$0.7V_{IO}$	-	5.5	V
V_{IL}	LOW-level input voltage		-0.3	-	$0.3V_{IO}$	V
I_{IH}	HIGH-level input current	$V_{STBN} = 0.7V_{IO}$	3	-	15	μA
I_{IL}	LOW-level input current	$V_{STBN} = 0\text{ V}$	-1	0	+1	μA
I_r	reverse current	Power-off mode; to V_{CC} / V_{IO} ; $V_{STBN} = 5\text{ V}$; $V_{CC} = V_{IO} = 0\text{ V}$	-5	0	+5	μA
Pin TXEN						
V_{IH}	HIGH-level input voltage		$0.7V_{IO}$	-	$V_{IO} + 0.3$	V
V_{IL}	LOW-level input voltage		-0.3	-	$0.3V_{IO}$	V
I_{IH}	HIGH-level input current	$V_{TXEN} = V_{IO}$	-1	0	+1	μA
I_{IL}	LOW-level input current	$V_{TXEN} = 0.3V_{IO}$	-300	-	-50	μA
I_r	reverse current	Power-off mode; to V_{CC} / V_{IO} ; $V_{TXEN} = 5\text{ V}$; $V_{CC} = V_{IO} = 0\text{ V}$	-5	0	+5	μA
Pin BGE						
V_{IH}	HIGH-level input voltage		$0.7V_{IO}$	-	5.5	V
V_{IL}	LOW-level input voltage		-0.3	-	$0.3V_{IO}$	V
I_{IH}	HIGH-level input current	$V_{BGE} = 0.7V_{IO}$	3	-	15	μA
I_{IL}	LOW-level input current	$V_{BGE} = 0\text{ V}$	-1	0	+1	μA
I_r	reverse current	Power-off mode; to V_{CC} / V_{IO} ; $V_{BGE} = 5\text{ V}$; $V_{CC} = V_{IO} = 0\text{ V}$	-5	0	+5	μA
Pin TXD						
V_{IH}	HIGH-level input voltage	Normal mode	$0.7V_{IO}$	-	$V_{IO} + 0.3$	V
V_{IL}	LOW-level input voltage	Normal mode	-0.3	-	$0.3V_{IO}$	V
I_{IH}	HIGH-level input current	$V_{TXD} = 0.7V_{IO}$	3	-	15	μA
I_{IL}	LOW-level input current	$V_{TXD} = 0\text{ V}$	-1	0	+1	μA
I_r	reverse current	Power-off mode; to V_{CC} / V_{IO} ; $V_{TXD} = 5\text{ V}$; $V_{CC} = V_{IO} = 0\text{ V}$	-5	0	+5	μA

Table 11. Static characteristics ...continued

All parameters are guaranteed for $V_{CC} = 4.5\text{ V to }5.25\text{ V}$; $V_{IO} = 2.6\text{ V to }5.25\text{ V}$; $T_{vj} = -40\text{ }^{\circ}\text{C to }+150\text{ }^{\circ}\text{C}$ and $R_{bus} = 45\ \Omega$ unless otherwise specified. All voltages are defined with respect to ground; positive currents flow into the IC.

Symbol	Parameter	Conditions	Min	Typ	Max	Unit
C_i	input capacitance	with respect to all other pins at ground; 11 $V_{TXD} = 100\text{ mV}$; $f = 5\text{ MHz}$	-	-	10	pF
Pin RXD						
I_{OH}	HIGH-level output current	$V_{RXD} = V_{IO} - 0.4\text{ V}$; $V_{IO} = V_{CC}$	-15	-	-1.7	mA
I_{OL}	LOW-level output current	$V_{RXD} = 0.4\text{ V}$	2	-	20	mA
Pin ERRN						
I_{OH}	HIGH-level output current	$V_{ERRN} = V_{IO} - 0.4\text{ V}$; $V_{IO} = V_{CC}$	-1500	-	-100	μA
I_{OL}	LOW-level output current	$V_{ERRN} = 0.4\text{ V}$	200	-	1700	μA
I_L	leakage current	Power-off mode; $V_{ERRN} \leq V_{IO}$	-5	-	+5	μA
Pin SDO						
I_{OH}	HIGH-level output current	$V_{SDO} = V_{IO} - 0.4\text{ V}$	-8	-3	-0.5	mA
I_{OL}	LOW-level output current	$V_{SDO} = 0.4\text{ V}$	0.8	3	9	mA
I_L	leakage current	high-impedance state; $0\text{ V} < V_{SDO} < V_{IO}$	-5	-	+5	μA
Pins BP and BM						
$V_{o(idle)(BP)}$	idle output voltage on pin BP	Normal mode; $V_{TXEN} = V_{IO}$; $R_{bus} = 45\ \Omega$	$0.4V_{CC}$	$0.5V_{CC}$	$0.6V_{CC}$	V
		Standby mode with no undervoltage on pin V_{CC}	-0.1	0	+0.1	V
$V_{o(idle)(BM)}$	idle output voltage on pin BM	Normal mode; $V_{TXEN} = V_{IO}$; $R_{bus} = 45\ \Omega$	$0.4V_{CC}$	$0.5V_{CC}$	$0.6V_{CC}$	V
		Standby mode with no undervoltage on pin V_{CC}	-0.1	0	+0.1	V
$I_{o(idle)BP}$	idle output current on pin BP	Normal and Standby modes with no undervoltage; $-60\text{ V} \leq V_{BP} \leq +60\text{ V}$	-7.5	-	+7.5	mA
$I_{o(idle)BM}$	idle output current on pin BM	Normal and Standby modes with no undervoltage; $-60\text{ V} \leq V_{BM} \leq +60\text{ V}$	-7.5	-	+7.5	mA
$V_{o(idle)(dif)}$	differential idle output voltage	Normal mode; $R_{bus} = 45\ \Omega$	-25	0	+25	mV
$V_{OH(dif)}$	differential HIGH-level output voltage	Normal mode; $40\ \Omega \leq R_{bus} \leq 55\ \Omega$; $C_{bus} = 100\text{ pF}$	600	1000	1500	mV
$V_{OL(dif)}$	differential LOW-level output voltage	Normal mode; $40\ \Omega \leq R_{bus} \leq 55\ \Omega$; $C_{bus} = 100\text{ pF}$	-1500	-1000	-600	mV
$V_{IH(dif)}$	differential HIGH-level input voltage	Normal mode; $-10\text{ V} \leq V_{BP} \leq +15\text{ V}$; $-10\text{ V} \leq V_{BM} \leq +15\text{ V}$	150	225	300	mV
$V_{IL(dif)}$	differential LOW-level input voltage	Normal mode; $-10\text{ V} \leq V_{BP} \leq +15\text{ V}$; $-10\text{ V} \leq V_{BM} \leq +15\text{ V}$	-300	-225	-150	mV
		Standby mode with no undervoltage on pin V_{CC} ; $-10\text{ V} \leq V_{BP} \leq +15\text{ V}$; $-10\text{ V} \leq V_{BM} \leq +15\text{ V}$	-400	-225	-125	mV
$ V_{i(dif)det(act)} $	activity detection differential input voltage (absolute value)		150	225	300	mV

Table 11. Static characteristics ...continued

All parameters are guaranteed for $V_{CC} = 4.5\text{ V to }5.25\text{ V}$; $V_{IO} = 2.6\text{ V to }5.25\text{ V}$; $T_{vj} = -40\text{ °C to }+150\text{ °C}$ and $R_{bus} = 45\ \Omega$ unless otherwise specified. All voltages are defined with respect to ground; positive currents flow into the IC.

Symbol	Parameter	Conditions	Min	Typ	Max	Unit
$ I_{O(sc)} $	short-circuit output current (absolute value)	on pin BP; $-5\text{ V} \leq V_{BP} \leq +60\text{ V}$	-	-	35	mA
		on pin BM; $-5\text{ V} \leq V_{BM} \leq +60\text{ V}$	-	-	35	mA
		on pins BP and BM; $V_{BP} = V_{BM}$; $-5\text{ V} \leq V_{BP} \leq +60\text{ V}$; $-5\text{ V} \leq V_{BM} \leq +60\text{ V}$	-	-	35	mA
$R_{i(BP)}$	input resistance on pin BP	$R_{bus} = \infty\ \Omega$	10	20	40	k Ω
$R_{i(BM)}$	input resistance on pin BM	$R_{bus} = \infty\ \Omega$	10	20	40	k Ω
$R_{i(dif)(BP-BM)}$	differential input resistance between pin BP and pin BM	$R_{bus} = \infty\ \Omega$	20	40	80	k Ω
$I_{L(BP)}$	input leakage current on pin BP	Power-off mode; $V_{CC} = V_{IO} = 0\text{ V}$; $0\text{ V} \leq V_{BP} \leq 5\text{ V}$	-5	0	+5	μA
		loss of ground; $V_{BP} = V_{BM} = 0\text{ V}$; all other pins connected to 16 V via $0\ \Omega$	[1] -1600	-	+1600	μA
$I_{L(BM)}$	input leakage current on pin BM	Power-off mode; $V_{CC} = V_{IO} = 0\text{ V}$; $0\text{ V} \leq V_{BM} \leq 5\text{ V}$	-5	0	+5	μA
		loss of ground; $V_{BP} = V_{BM} = 0\text{ V}$; all other pins connected to 16 V via $0\ \Omega$	[1] -1600	-	+1600	μA
$V_{cm(bus)(DATA_0)}$	DATA_0 bus common-mode voltage	Normal mode; $R_{bus} = 45\ \Omega$	$0.4V_{CC}$	$0.5V_{CC}$	$0.6V_{CC}$	V
$V_{cm(bus)(DATA_1)}$	DATA_1 bus common-mode voltage	Normal mode; $R_{bus} = 45\ \Omega$	$0.4V_{CC}$	$0.5V_{CC}$	$0.6V_{CC}$	V
$\Delta V_{cm(bus)}$	bus common-mode voltage difference	Normal mode; DATA_1 – DATA_0; $R_{bus} = 45\ \Omega$	-25	0	+25	mV
$\Delta V_{cm(act-idle)}$	active to idle common-mode voltage difference	Normal mode; $R_{bus} = 45\ \Omega$	-300	0	+300	mV
$\Delta V_{i(dif)(H-L)}$	differential input voltage difference between HIGH-level and LOW-level	Normal mode; $(V_{BP} + V_{BM})/2 = 2.5\text{ V}$	-	-	10	%
$C_{i(BP)}$	input capacitance on pin BP	with respect to all other pins at ground; $V_{BP} = 100\text{ mV}$; $f = 5\text{ MHz}$	[1] -	-	15	pF
$C_{i(BM)}$	input capacitance on pin BM	with respect to all other pins at ground; $V_{BM} = 100\text{ mV}$; $f = 5\text{ MHz}$	[1] -	-	15	pF
$C_{i(dif)(BP-BM)}$	differential input capacitance between pin BP and pin BM	with respect to all other pins at ground; $V_{BP} = 100\text{ mV}$; $V_{BM} = 100\text{ mV}$; $f = 5\text{ MHz}$	[1] -	-	5	pF
Temperature protection						
$T_{j(dis)(high)}$	high disable junction temperature		180	-	200	$^{\circ}\text{C}$

[1] Guaranteed by design.

10. Dynamic characteristics

Table 12. Dynamic characteristics

All parameters are guaranteed for $V_{CC} = 4.5\text{ V to }5.25\text{ V}$; $V_{IO} = 2.6\text{ V to }5.25\text{ V}$; $T_{vj} = -40\text{ }^{\circ}\text{C to }+150\text{ }^{\circ}\text{C}$ and $R_{bus} = 45\ \Omega$ unless otherwise specified. All voltages are defined with respect to ground; positive currents flow into the IC.

Symbol	Parameter	Conditions	Min	Typ	Max	Unit
Pins BP and BM						
$t_{d(\text{TXD-bus})}$	delay time from TXD to bus	Normal mode	[1][2]			
		DATA_0	-	-	50	ns
		DATA_1	-	-	50	ns
$\Delta t_{d(\text{TXD-bus})}$	delay time difference from TXD to bus	Normal mode; between DATA_0 and DATA_1	[1][2] -4	-	+4	ns
$t_{d(\text{bus-RXD})}$	delay time from bus to RXD	Normal mode; $C_{RXD} = 15\text{ pF}$; $(V_{BP} + V_{BM})/2 = 2.5\text{ V}$	[3]			
		DATA_0	-	-	50	ns
		DATA_1	-	-	50	ns
		Normal mode; $C_{RXD} = 25\text{ pF}$; $(V_{BP} + V_{BM})/2 = 2.5\text{ V}$	[3]			
		DATA_0	-	-	60	ns
		DATA_1	-	-	60	ns
$\Delta t_{d(\text{bus-RXD})}$	delay time difference from bus to RXD	Normal mode; between DATA_0 and DATA_1; $(V_{BP} + V_{BM})/2 = 2.5\text{ V}$	[3]			
		$C_{RXD} = 15\text{ pF}$	-5	-	5	ns
		$C_{RXD} = 25\text{ pF}$	-6	-	6	ns
$t_{d(\text{TXEN-busidle})}$	delay time from TXEN to bus idle	Normal mode; $V_{TXD} = 0\text{ V}$	-	-	75	ns
$t_{d(\text{TXEN-busact})}$	delay time from TXEN to bus active	Normal mode; $V_{TXD} = 0\text{ V}$	-	-	75	ns
$ \Delta t_{d(\text{TXEN-bus})} $	delay time difference from TXEN to bus (absolute value)	Normal mode; between TXEN to bus active and TXEN to bus idle; $V_{TXD} = 0\text{ V}$	[4]		50	ns
$t_{d(\text{BGE-busidle})}$	delay time from BGE to bus idle	Normal mode; $V_{TXD} = 0\text{ V}$	-	-	75	ns
$t_{d(\text{BGE-busact})}$	delay time from BGE to bus active	Normal mode; $V_{TXD} = 0\text{ V}$	-	-	75	ns
$t_{r(\text{dif})(\text{bus})}$	bus differential rise time	DATA_0 to DATA_1; 20 % to 80 %; $R_{bus} = 45\ \Omega$; $C_{bus} = 100\text{ pF}$	[5] 3.75	-	18.75	ns
$t_{f(\text{dif})(\text{bus})}$	bus differential fall time	DATA_1 to DATA_0; 80 % to 20 %; $R_{bus} = 45\ \Omega$; $C_{bus} = 100\text{ pF}$	[5] 3.75	-	18.75	ns
$\Delta t_{(r-f)(\text{dif})}$	difference between differential rise and fall time	on bus; 80 % to 20 % $R_{bus} = 45\ \Omega$; $C_{bus} = 100\text{ pF}$	[5] -3	-	3	ns
$t_{f(\text{bus})(\text{idle-act})}$	bus fall time from idle to active	bus idle to DATA_0; $R_{bus} = 45\ \Omega$; $C_{bus} = 100\text{ pF}$; $-30\text{ mV} > V_{dif} > -300\text{ mV}$	[5][6] -	-	30	ns
$t_{f(\text{bus})(\text{act-idle})}$	bus fall time from active to idle	DATA_1 to bus idle; $R_{bus} = 45\ \Omega$; $C_{bus} = 100\text{ pF}$; $300\text{ mV} > V_{dif} > 30\text{ mV}$	[5][6] -	-	30	ns

Table 12. Dynamic characteristics ...continued

All parameters are guaranteed for $V_{CC} = 4.5\text{ V to }5.25\text{ V}$; $V_{IO} = 2.6\text{ V to }5.25\text{ V}$; $T_{vj} = -40\text{ }^{\circ}\text{C to }+150\text{ }^{\circ}\text{C}$ and $R_{bus} = 45\ \Omega$ unless otherwise specified. All voltages are defined with respect to ground; positive currents flow into the IC.

Symbol	Parameter	Conditions	Min	Typ	Max	Unit
$t_{r(\text{bus})}(\text{act-idle})$	bus rise time from active to idle	DATA_0 to bus idle; $C_{bus} = 100\text{ pF}$; $-300\text{ mV} < V_{\text{dif}} < -30\text{ mV}$	[5][6]	-	30	ns
Wake-up detection						
$t_{\text{det}(\text{wake})\text{DATA}_0}$	DATA_0 wake-up detection time	Standby mode with no undervoltage on pin V_{CC} ; $-10\text{ V} \leq V_{BP} \leq +15\text{ V}$; $-10\text{ V} \leq V_{BM} \leq +15\text{ V}$	[7]	1	4	μs
$t_{\text{det}(\text{wake})\text{idle}}$	idle wake-up detection time	Standby mode with no undervoltage on pin V_{CC} ; $-10\text{ V} \leq V_{BP} \leq +15\text{ V}$; $-10\text{ V} \leq V_{BM} \leq +15\text{ V}$	[7]	1	4	μs
$t_{\text{det}(\text{wake})\text{tot}}$	total wake-up detection time	Standby mode with no undervoltage on pin V_{CC} ; $-10\text{ V} \leq V_{BP} \leq +15\text{ V}$; $-10\text{ V} \leq V_{BM} \leq +15\text{ V}$	[7]	50	115	μs
$t_{\text{sup}(\text{int})\text{wake}}$	wake-up interruption suppression time	Standby mode with no undervoltage on pin V_{CC} ; $-10\text{ V} \leq V_{BP} \leq +15\text{ V}$; $-10\text{ V} \leq V_{BM} \leq +15\text{ V}$	[8]	130	-	ns
Undervoltage						
$t_{\text{det}(\text{uv})\text{(VCC)}}$	undervoltage detection time on pin V_{CC}	$0\text{ V} \leq V_{IO} \leq 5.5\text{ V}$; $V_{CC} = 4.4\text{ V}$		2	100	μs
$t_{\text{rec}(\text{uv})\text{(VCC)}}$	undervoltage recovery time on pin V_{CC}	$0\text{ V} \leq V_{IO} \leq 5.5\text{ V}$; $V_{CC} = 4.85\text{ V}$		2	100	μs
$t_{\text{det}(\text{uv})\text{(VIO)}}$	undervoltage detection time on pin V_{IO}	$V_{\text{th}(\text{det})\text{POR}} < V_{CC} < 5.5\text{ V}$; $V_{IO} = 2.5\text{ V}$		5	100	μs
$t_{\text{rec}(\text{uv})\text{(VIO)}}$	undervoltage recovery time on pin V_{IO}	$V_{\text{th}(\text{det})\text{POR}} < V_{CC} < 5.5\text{ V}$; $V_{IO} = 2.9\text{ V}$		5	100	μs
Activity detection						
$t_{\text{det}(\text{act})\text{(bus)}}$	activity detection time on bus pins	Normal mode; $V_{\text{dif}}: 0\text{ mV} \rightarrow 400\text{ mV}$; $(V_{BP} + V_{BM})/2 = 2.5\text{ V}$	[6]	100	250	ns
$t_{\text{det}(\text{idle})\text{(bus)}}$	idle detection time on bus pins	Normal mode; $V_{\text{dif}}: 400\text{ mV} \rightarrow 0\text{ mV}$; $(V_{BP} + V_{BM})/2 = 2.5\text{ V}$	[6]	100	250	ns
$ \Delta t_{\text{det}(\text{act-idle})} $	active to idle detection time difference (absolute value)	Normal mode; on bus pins; $(V_{BP} + V_{BM})/2 = 2.5\text{ V}$		-	150	ns
ERRN signalling						
$t_{\text{det}(\text{L})\text{(SCLK)}}$	LOW-level detection time on pin SCLK	Normal or Standby mode with no undervoltage on pin V_{IO}		95	310	μs
SPI						
$t_{\text{d}(\text{SCSNHL-SDOL})}$	SCSN falling edge to SDO LOW-level delay time	$V_{\text{uvd}(\text{VIO})} < V_{IO} < 5.5\text{ V}$; $4.5\text{ V} < V_{CC} < 5.5\text{ V}$; $C_{\text{SDO}} = 50\text{ pF}$	[9]	-	250	ns

Table 12. Dynamic characteristics ...continued

All parameters are guaranteed for $V_{CC} = 4.5\text{ V to }5.25\text{ V}$; $V_{IO} = 2.6\text{ V to }5.25\text{ V}$; $T_{vj} = -40\text{ °C to }+150\text{ °C}$ and $R_{bus} = 45\ \Omega$ unless otherwise specified. All voltages are defined with respect to ground; positive currents flow into the IC.

Symbol	Parameter	Conditions	Min	Typ	Max	Unit
$t_{d(SCLKLH-SDODV)}$	SCLK rising edge to SDO data valid delay time	$V_{uvd(VIO)} < V_{IO} < 5.5\text{ V}$; $4.5\text{ V} < V_{CC} < 5.5\text{ V}$; $C_{SDO} = 50\text{ pF}$	[9]	-	200	ns
$t_{d(SCSNLH-SDOZ)}$	SCSN rising edge to SDO three-state delay time	$V_{uvd(VIO)} < V_{IO} < 5.5\text{ V}$; $4.5\text{ V} < V_{CC} < 5.5\text{ V}$; $C_{SDO} = 50\text{ pF}$	[9]	-	500	ns
T_{SCLK}	SCLK period	$V_{uvd(VIO)} < V_{IO} < 5.5\text{ V}$; $4.5\text{ V} < V_{CC} < 5.5\text{ V}$; $C_{SDO} = 50\text{ pF}$	[9]	0.5	100	μs
$t_{SPILEAD}$	SPI enable lead time	$V_{uvd(VIO)} < V_{IO} < 5.5\text{ V}$; $4.5\text{ V} < V_{CC} < 5.5\text{ V}$; $C_{SDO} = 50\text{ pF}$	[9]	250	-	ns
t_{SPILAG}	SPI enable lag time	$V_{uvd(VIO)} < V_{IO} < 5.5\text{ V}$; $4.5\text{ V} < V_{CC} < 5.5\text{ V}$; $C_{SDO} = 50\text{ pF}$	[9]	250	-	ns
RXD						
t_r	rise time	20 % to 80 %; $C_{RXD} = 15\text{ pF}$	[4]	-	5	ns
		20 % to 80 %; $C_{RXD} = 25\text{ pF}$	[4]	-	9	ns
t_f	fall time	80 % to 20 %; $C_{RXD} = 15\text{ pF}$	[4]	-	5	ns
		80 % to 20 %; $C_{RXD} = 25\text{ pF}$	[4]	-	9	ns
$\Delta t_{(r-f)}$	difference between rise and fall time	$C_{RXD} = 15\text{ pF}$	[4]	-4	4	ns
		$C_{RXD} = 25\text{ pF}$	[4]	-7	7	ns
Bus error flag						
$t_{d(norm-stb)}$	normal mode to standby delay time	bus error flag set	3	-	10	μs
$t_{d(stb-norm)}$	standby to normal mode delay time	bus error flag set	3	-	10	μs
Miscellaneous						
$t_{detCL(TXEN)}$	TXEN clamp detection time	$4.5\text{ V} < V_{CC} < 5.5\text{ V}$	1500	-	2600	μs
$t_{detCL(BGE)}$	BGE clamp detection time	$4.5\text{ V} < V_{CC} < 5.5\text{ V}$	1500	-	2600	μs

[1] Rise and fall time (10 % to 90 %) of $t_{r(TXD)}$ and $t_{f(TXD)} = 5 \pm 1\text{ ns}$.

[2] See [Figure 14](#).

[3] See [Figure 15](#).

[4] Guaranteed by design.

[5] See [Figure 17](#).

[6] $V_{dif} = V_{BP} - V_{BM}$.

[7] See [Figure 8](#).

[8] See [Figure 10](#).

[9] See [Figure 12](#).

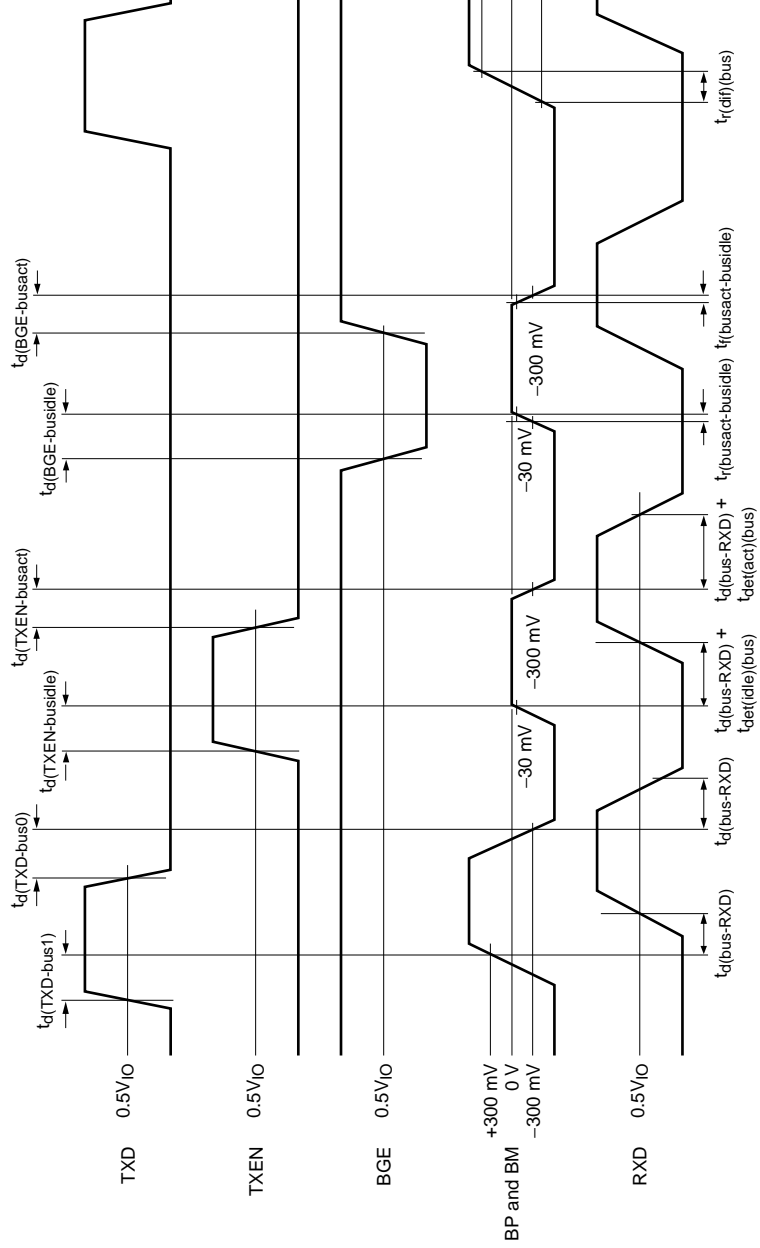
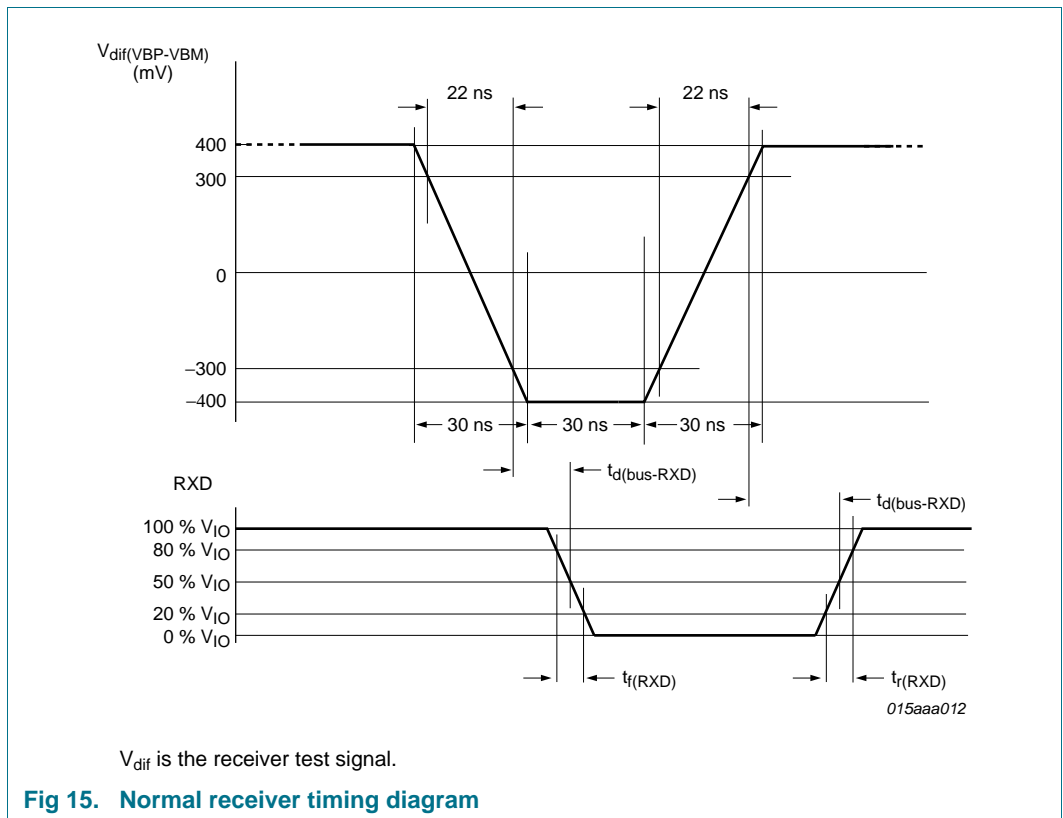
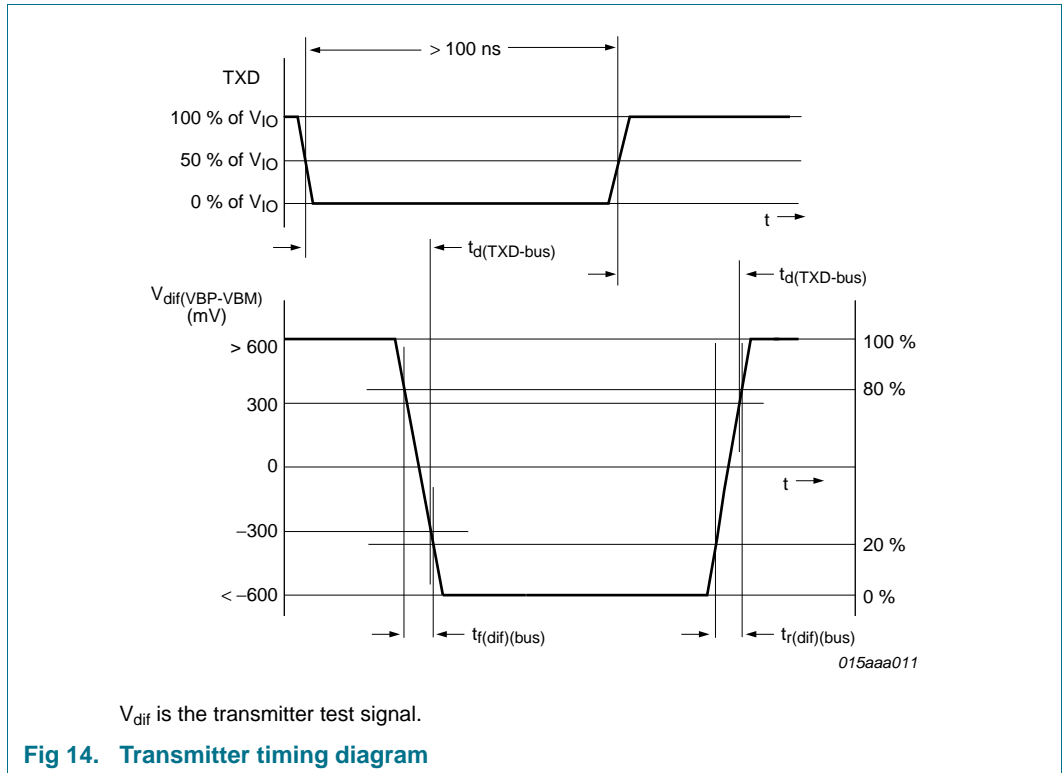

Fig 13. Detailed timing diagram



11. Test information

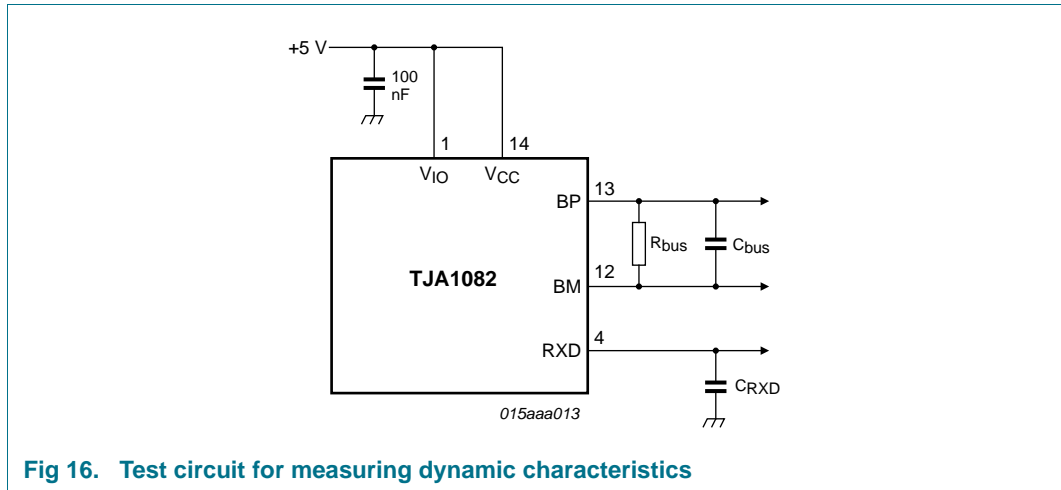
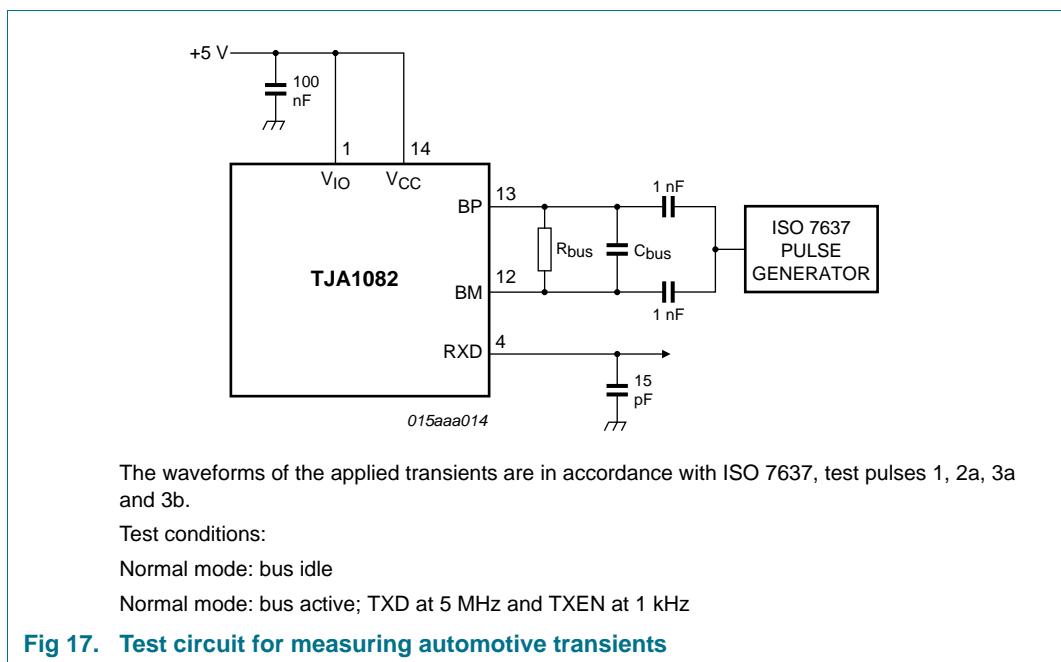

Fig 16. Test circuit for measuring dynamic characteristics



The waveforms of the applied transients are in accordance with ISO 7637, test pulses 1, 2a, 3a and 3b.

Test conditions:

Normal mode: bus idle

Normal mode: bus active; TXD at 5 MHz and TXEN at 1 kHz

Fig 17. Test circuit for measuring automotive transients

12. Package outline

TSSOP14: plastic thin shrink small outline package; 14 leads; body width 4.4 mm

SOT402-1

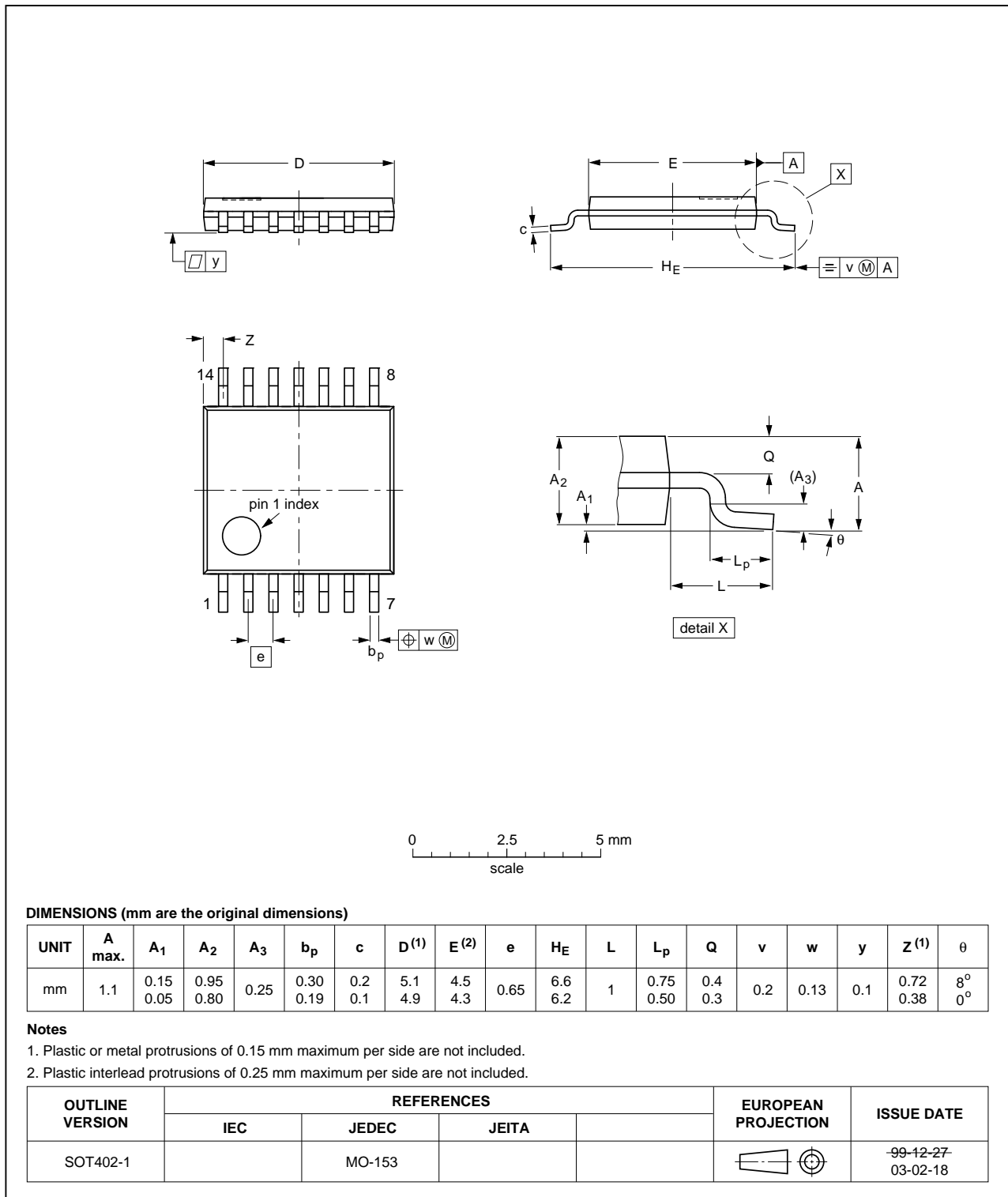

Fig 18. Package outline SOT402-1 (TSSOP14)

13. Soldering of SMD packages

This text provides a very brief insight into a complex technology. A more in-depth account of soldering ICs can be found in Application Note *AN10365 "Surface mount reflow soldering description"*.

13.1 Introduction to soldering

Soldering is one of the most common methods through which packages are attached to Printed Circuit Boards (PCBs), to form electrical circuits. The soldered joint provides both the mechanical and the electrical connection. There is no single soldering method that is ideal for all IC packages. Wave soldering is often preferred when through-hole and Surface Mount Devices (SMDs) are mixed on one printed wiring board; however, it is not suitable for fine pitch SMDs. Reflow soldering is ideal for the small pitches and high densities that come with increased miniaturization.

13.2 Wave and reflow soldering

Wave soldering is a joining technology in which the joints are made by solder coming from a standing wave of liquid solder. The wave soldering process is suitable for the following:

- Through-hole components
- Leaded or leadless SMDs, which are glued to the surface of the printed circuit board

Not all SMDs can be wave soldered. Packages with solder balls, and some leadless packages which have solder lands underneath the body, cannot be wave soldered. Also, leaded SMDs with leads having a pitch smaller than ~0.6 mm cannot be wave soldered, due to an increased probability of bridging.

The reflow soldering process involves applying solder paste to a board, followed by component placement and exposure to a temperature profile. Leaded packages, packages with solder balls, and leadless packages are all reflow solderable.

Key characteristics in both wave and reflow soldering are:

- Board specifications, including the board finish, solder masks and vias
- Package footprints, including solder thieves and orientation
- The moisture sensitivity level of the packages
- Package placement
- Inspection and repair
- Lead-free soldering versus SnPb soldering

13.3 Wave soldering

Key characteristics in wave soldering are:

- Process issues, such as application of adhesive and flux, clinching of leads, board transport, the solder wave parameters, and the time during which components are exposed to the wave
- Solder bath specifications, including temperature and impurities

13.4 Reflow soldering

Key characteristics in reflow soldering are:

- Lead-free versus SnPb soldering; note that a lead-free reflow process usually leads to higher minimum peak temperatures (see [Figure 19](#)) than a SnPb process, thus reducing the process window
- Solder paste printing issues including smearing, release, and adjusting the process window for a mix of large and small components on one board
- Reflow temperature profile; this profile includes preheat, reflow (in which the board is heated to the peak temperature) and cooling down. It is imperative that the peak temperature is high enough for the solder to make reliable solder joints (a solder paste characteristic). In addition, the peak temperature must be low enough that the packages and/or boards are not damaged. The peak temperature of the package depends on package thickness and volume and is classified in accordance with [Table 13](#) and [14](#)

Table 13. SnPb eutectic process (from J-STD-020C)

Package thickness (mm)	Package reflow temperature (°C)	
	Volume (mm ³)	
	< 350	≥ 350
< 2.5	235	220
≥ 2.5	220	220

Table 14. Lead-free process (from J-STD-020C)

Package thickness (mm)	Package reflow temperature (°C)		
	Volume (mm ³)		
	< 350	350 to 2000	> 2000
< 1.6	260	260	260
1.6 to 2.5	260	250	245
> 2.5	250	245	245

Moisture sensitivity precautions, as indicated on the packing, must be respected at all times.

Studies have shown that small packages reach higher temperatures during reflow soldering, see [Figure 19](#).

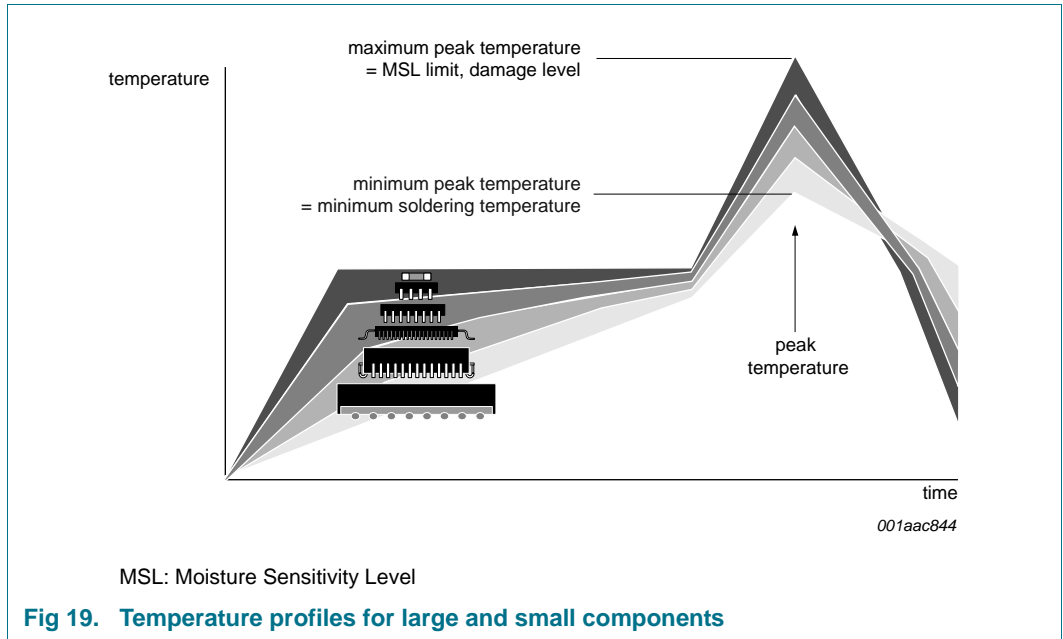

For further information on temperature profiles, refer to Application Note AN10365 “Surface mount reflow soldering description”.

14. Appendix

14.1 EPL 3.0.1 requirements implemented in the TJA1082

Table 15. EPL 3.0.1 requirements implemented

EPL 3.0.1 parameter	Description
-	wake-up via dedicated data frames
dBusTxDif	difference between rise and fall times: ≤ 3 ns
R _{DCLoad}	transmitter output voltage defined for DC bus load of 40 Ω to 55 Ω /100 pF
-	transmission not allowed to start with DATA_1
dBDTx10, dBDTx01	transmitter delay: ≤ 75 ns
dBDTxia, dBDTxai	transmitter idle-to-active/active-to-idle transition delay: ≤ 75 ns
dBDTxDM	transmitter idle-to-active delay mismatch: ± 50 ns
uData0_LP	receiver thresholds for detecting DATA_0 in low-power modes: -400 mV (min)/ -100 mV (max)
dBDRxai	idle reaction time: 50 ns to 275 ns
dBDAActivityDetection	activity detection time 100 ns to 250 ns
dBDRxia	activity reaction time: 100 ns to 325 ns
uData1 – uData0	receiver threshold mismatch: ≤ 30 mV
dBDRx10, dBDRx01	receiver delay: ≤ 75 ns
dBusRx0BD, dBusRx1BD	minimum bit time: 70 ns
C_StarTxD, C_BDTxD	maximum input capacitance on pin TXD: 10 pF
dBDRxD _{R15} + dBDRxD _{F15}	sum of RXD rise and fall times (20%/80%): ≤ 13 ns with a 15 pF load
dBDTxRxai	idle loop delay: ≤ 325 ns
dStarTxActiveMax	TXEN timeout: 650 μ s to 2600 μ s
-	BD_Off mode defined (TJA1082 Power-off mode)
dBDModeChange	Reaction time to mode change request 100 μ s (max)
-	Short circuit currents:
iBP _{BMSHORTMax} , iBM _{BPSHORTMax}	BP shorted to BM: < 60 mA; no time limit
iBP _{GNDSHORTMax} , iBM _{GNDSHORTMax}	BP/BM shorted to ground: < 60 mA; no time limit
iBP _{-5SHORTMax} , iBM _{-5SHORTMax}	BP/BM shorted to -5 V: < 60 mA; no time limit
iBP _{BAT48SHORTMax} , iBM _{BAT27SHORTMax}	BP/BM shorted to 27 V: < 60 mA; no time limit
iBP _{BAT48SHORTMax} , iBM _{BAT27SHORTMax}	BP/BM shorted to 48 V: < 72 mA; no time limit
iBP _{BAT60SHORTMax} , iBM _{BAT60SHORTMax}	BP/BM shorted to 60 V: < 90 mA; for 400 ms (max)
-	ERRN output signals errors including wake-up status and wake-up source
iBP _{LeakGND} , iBM _{LeakGND}	leakage current on BP/BM in case of loss of GND 1600 μ A (max)
uBDUVV _{CC}	V _{CC} undervoltage detection threshold: > 4 V
uUV _{IO}	V _{IO} undervoltage detection threshold: > 2 V; detection timeout 1000 ms (max)
dBDRV _{CC} , dBDRV _{IO} , dStarRV _{BAT}	V _{CC} /V _{IO} /V _{BAT} undervoltage recovery time: 10 ms (max)
-	Qualification according to AEC-Q100 temperature classes
uESDExt	6 kV ESD (min) on pins BP and BM according to HBM (100 pF/1500 Ω)
uESDInt	2 kV ESD (min) on all other pins according to HBM (100 pF/1500 Ω)
uESDIEC	6 kV ESD (min) on pins BP and BM according to IEC 61000-4-2

15. Abbreviations

Table 16. Abbreviations

Abbreviation	Description
CDM	Charged Device Model
ECU	Electronic Control Unit
EMC	ElectroMagnetic Compatibility
EME	ElectroMagnetic Emission
EMI	ElectroMagnetic Immunity
ESD	ElectroStatic Discharge
HBM	Human Body Model
MM	Machine Model
PWON	Power-on

16. References

- [1] **EPL** — FlexRay Communications System Electrical Physical Layer Specification Version 2.1 Rev. B, FlexRay Consortium, Nov 2006
- [2] **EPL** — FlexRay Communications System Electrical Physical Layer Specification Version 3.0.1, FlexRay Consortium
- [3] **AN** — Application hint AN10365 - Surface mount reflow soldering description

17. Revision history

Table 17. Revision history

Document ID	Release date	Data sheet status	Change notice	Supersedes
TJA1082 v.6	20121128	Product data sheet	-	TJA1082 v.5
Modifications:		<ul style="list-style-type: none"> • Section 6.2.1, Section 6.8: text revised • Table 9: parameter values revised: V_{CC}, V_{IO} • Table 12: parameter conditions revised: $t_{r(\text{bus})(\text{act-idle})}$ 		
TJA1082 v.5	20120620	Product data sheet	-	TJA1082 v.4
TJA1082 v.4	20120613	Product data sheet	-	TJA1082 v.3
TJA1082 v.3	20110224	Product data sheet	-	TJA1082 v.2
TJA1082 v.2	20090810	Product data sheet	-	TJA1082 v.1
TJA1082 v.1	20090701	Preliminary data sheet	-	-

18. Legal information

18.1 Data sheet status

Document status ^{[1][2]}	Product status ^[3]	Definition
Objective [short] data sheet	Development	This document contains data from the objective specification for product development.
Preliminary [short] data sheet	Qualification	This document contains data from the preliminary specification.
Product [short] data sheet	Production	This document contains the product specification.

[1] Please consult the most recently issued document before initiating or completing a design.

[2] The term 'short data sheet' is explained in section "Definitions".

[3] The product status of device(s) described in this document may have changed since this document was published and may differ in case of multiple devices. The latest product status information is available on the Internet at URL <http://www.nxp.com>.

18.2 Definitions

Draft — The document is a draft version only. The content is still under internal review and subject to formal approval, which may result in modifications or additions. NXP Semiconductors does not give any representations or warranties as to the accuracy or completeness of information included herein and shall have no liability for the consequences of use of such information.

Short data sheet — A short data sheet is an extract from a full data sheet with the same product type number(s) and title. A short data sheet is intended for quick reference only and should not be relied upon to contain detailed and full information. For detailed and full information see the relevant full data sheet, which is available on request via the local NXP Semiconductors sales office. In case of any inconsistency or conflict with the short data sheet, the full data sheet shall prevail.

Product specification — The information and data provided in a Product data sheet shall define the specification of the product as agreed between NXP Semiconductors and its customer, unless NXP Semiconductors and customer have explicitly agreed otherwise in writing. In no event however, shall an agreement be valid in which the NXP Semiconductors product is deemed to offer functions and qualities beyond those described in the Product data sheet.

18.3 Disclaimers

Limited warranty and liability — Information in this document is believed to be accurate and reliable. However, NXP Semiconductors does not give any representations or warranties, expressed or implied, as to the accuracy or completeness of such information and shall have no liability for the consequences of use of such information. NXP Semiconductors takes no responsibility for the content in this document if provided by an information source outside of NXP Semiconductors.

In no event shall NXP Semiconductors be liable for any indirect, incidental, punitive, special or consequential damages (including - without limitation - lost profits, lost savings, business interruption, costs related to the removal or replacement of any products or rework charges) whether or not such damages are based on tort (including negligence), warranty, breach of contract or any other legal theory.

Notwithstanding any damages that customer might incur for any reason whatsoever, NXP Semiconductors' aggregate and cumulative liability towards customer for the products described herein shall be limited in accordance with the *Terms and conditions of commercial sale* of NXP Semiconductors.

Right to make changes — NXP Semiconductors reserves the right to make changes to information published in this document, including without limitation specifications and product descriptions, at any time and without notice. This document supersedes and replaces all information supplied prior to the publication hereof.

Suitability for use in automotive applications — This NXP Semiconductors product has been qualified for use in automotive applications. Unless otherwise agreed in writing, the product is not designed, authorized or warranted to be suitable for use in life support, life-critical or safety-critical systems or equipment, nor in applications where failure or malfunction of an NXP Semiconductors product can reasonably be expected to result in personal injury, death or severe property or environmental damage. NXP Semiconductors and its suppliers accept no liability for inclusion and/or use of NXP Semiconductors products in such equipment or applications and therefore such inclusion and/or use is at the customer's own risk.

Applications — Applications that are described herein for any of these products are for illustrative purposes only. NXP Semiconductors makes no representation or warranty that such applications will be suitable for the specified use without further testing or modification.

Customers are responsible for the design and operation of their applications and products using NXP Semiconductors products, and NXP Semiconductors accepts no liability for any assistance with applications or customer product design. It is customer's sole responsibility to determine whether the NXP Semiconductors product is suitable and fit for the customer's applications and products planned, as well as for the planned application and use of customer's third party customer(s). Customers should provide appropriate design and operating safeguards to minimize the risks associated with their applications and products.

NXP Semiconductors does not accept any liability related to any default, damage, costs or problem which is based on any weakness or default in the customer's applications or products, or the application or use by customer's third party customer(s). Customer is responsible for doing all necessary testing for the customer's applications and products using NXP Semiconductors products in order to avoid a default of the applications and the products or of the application or use by customer's third party customer(s). NXP does not accept any liability in this respect.

Limiting values — Stress above one or more limiting values (as defined in the Absolute Maximum Ratings System of IEC 60134) will cause permanent damage to the device. Limiting values are stress ratings only and (proper) operation of the device at these or any other conditions above those given in the Recommended operating conditions section (if present) or the Characteristics sections of this document is not warranted. Constant or repeated exposure to limiting values will permanently and irreversibly affect the quality and reliability of the device.

Terms and conditions of commercial sale — NXP Semiconductors products are sold subject to the general terms and conditions of commercial sale, as published at <http://www.nxp.com/profile/terms>, unless otherwise agreed in a valid written individual agreement. In case an individual agreement is concluded only the terms and conditions of the respective agreement shall apply. NXP Semiconductors hereby expressly objects to applying the customer's general terms and conditions with regard to the purchase of NXP Semiconductors products by customer.

No offer to sell or license — Nothing in this document may be interpreted or construed as an offer to sell products that is open for acceptance or the grant, conveyance or implication of any license under any copyrights, patents or other industrial or intellectual property rights.

Export control — This document as well as the item(s) described herein may be subject to export control regulations. Export might require a prior authorization from competent authorities.

Translations — A non-English (translated) version of a document is for reference only. The English version shall prevail in case of any discrepancy between the translated and English versions.

18.4 Licenses

NXP ICs with FlexRay functionality

This NXP product contains functionality that is compliant with the FlexRay specifications.

These specifications and the material contained in them, as released by the FlexRay Consortium, are for the purpose of information only. The FlexRay Consortium and the companies that have contributed to the specifications shall not be liable for any use of the specifications.

The material contained in these specifications is protected by copyright and other types of Intellectual Property Rights. The commercial exploitation of the material contained in the specifications requires a license to such Intellectual Property Rights.

These specifications may be utilized or reproduced without any modification, in any form or by any means, for informational purposes only. For any other purpose, no part of the specifications may be utilized or reproduced, in any form or by any means, without permission in writing from the publisher.

The FlexRay specifications have been developed for automotive applications only. They have neither been developed nor tested for non-automotive applications.

The word FlexRay and the FlexRay logo are registered trademarks.

18.5 Trademarks

Notice: All referenced brands, product names, service names and trademarks are the property of their respective owners.

19. Contact information

For more information, please visit: <http://www.nxp.com>

For sales office addresses, please send an email to: salesaddresses@nxp.com

20. Contents

1	General description	1	14	Appendix	33
2	Features and benefits	1	14.1	EPL 3.0.1 requirements implemented in the TJA1082	33
2.1	Optimized for time triggered communication systems	1	15	Abbreviations	34
2.2	Low power management	1	16	References	34
2.3	Diagnosis and robustness	2	17	Revision history	35
2.4	FlexRay conformance classes	2	18	Legal information	36
3	Ordering information	2	18.1	Data sheet status	36
4	Block diagram	3	18.2	Definitions	36
5	Pinning information	4	18.3	Disclaimers	36
5.1	Pinning	4	18.4	Licenses	37
5.2	Pin description	4	18.5	Trademarks	37
6	Functional description	4	19	Contact information	37
6.1	Power modes	4	20	Contents	38
6.1.1	Normal mode	5			
6.1.1.1	Bus activity and idle detection	7			
6.1.2	Standby mode	7			
6.1.3	Power-off mode	7			
6.1.4	State transitions	7			
6.2	Power-up and power-down behavior	9			
6.2.1	Power-up	9			
6.2.2	Power-down	10			
6.3	Remote wake-up	11			
6.3.1	Bus wake-up via wake-up pattern	11			
6.3.2	Bus wake-up via dedicated FlexRay data frame	12			
6.4	Bus error detection	13			
6.5	Fail silent behavior	13			
6.6	TJA1082 flags	13			
6.7	TJA1082 status register	14			
6.8	Error signalling	15			
6.8.1	SPI mode	16			
6.8.2	Simple error indication mode	16			
6.9	SPI interface	16			
7	Limiting values	17			
8	Thermal characteristics	18			
9	Static characteristics	19			
10	Dynamic characteristics	23			
11	Test information	28			
12	Package outline	29			
13	Soldering of SMD packages	30			
13.1	Introduction to soldering	30			
13.2	Wave and reflow soldering	30			
13.3	Wave soldering	30			
13.4	Reflow soldering	31			

Please be aware that important notices concerning this document and the product(s) described herein, have been included in section 'Legal information'.

© NXP B.V. 2012. All rights reserved.

For more information, please visit: <http://www.nxp.com>
For sales office addresses, please send an email to: salesaddresses@nxp.com

Date of release: 28 November 2012
Document identifier: TJA1082

Looking for pricing, stock, or lifecycle information?

Click below to explore more details on WIN SOURCE:

- ⊖ [View TJA1082TT,118 on WIN SOURCE](#)
- ⊖ [NXP / Nexperia Information](#)

Optimize Your Supply Chain with WIN SOURCE Solutions

- ✓ Global Sourcing Solution
- ✓ Obsolete Management
- ✓ Cost Control Management
- ✓ Shortage Management
- ✓ Alternative Solution
- ✓ Excess Inventory Management