



**THE DATASHEET OF  
TJA1081TS,118**





# TJA1081

FlexRay node transceiver

Rev. 5 — 28 November 2012

Product data sheet

## 1. General description

---

The TJA1081 is a FlexRay node transceiver that is fully compliant with the FlexRay electrical physical layer specification V2.1 Rev. A (see [Ref. 1](#)). In addition, it incorporates features and parameters included in V3.0.1 (see [Ref. 2](#) and [Section 14](#)). It is primarily intended for communication systems from 1 Mbit/s to 10 Mbit/s, and provides an advanced interface between the protocol controller and the physical bus in a FlexRay network.

The TJA1081 features enhanced low-power modes, optimized for ECUs that are permanently connected to the battery.

The TJA1081 provides differential transmit capability to the network and differential receive capability to the FlexRay controller. It offers excellent EMC performance as well as high ESD protection.

The TJA1081 actively monitors system performance using dedicated error and status information (that can be read by any microcontroller), along with internal voltage and temperature monitoring.

The TJA1081 supports mode control as used in the TJA1080A (see [Ref. 3](#)).

## 2. Features and benefits

---

### 2.1 Optimized for time triggered communication systems

- Compliant with FlexRay electrical physical layer specification V2.1 Rev. A (see [Ref. 1](#))
- Automotive product qualification in accordance with AEC-Q100
- Data transfer up to 10 Mbit/s
- Support of 60 ns minimum bit time
- Very low ElectroMagnetic Emission (EME) to support unshielded cable
- Differential receiver with wide common-mode range for high ElectroMagnetic Immunity (EMI)
- Auto I/O level adaptation to host controller supply voltage  $V_{IO}$
- Can be used in 14 V and 42 V powered systems
- Instant shut-down interface (via BGE pin)
- Independent power supply ramp-up for  $V_{BAT}$ ,  $V_{CC}$  and  $V_{IO}$

### 2.2 Low power management

- Low power management including inhibit switch
- Very low current in Sleep and Standby modes



- Local and remote wake-up
- Supports remote wake-up via dedicated data frames
- Wake-up source recognition

### 2.3 Diagnosis (detection and signalling)

- Overtemperature detection
- Short-circuit on bus lines
- $V_{BAT}$  power-on flag (first battery connection and cold start)
- Pin TXEN and pin BGE clamping
- Undervoltage detection on pins  $V_{BAT}$ ,  $V_{CC}$  and  $V_{IO}$
- Wake source indication

### 2.4 Protection

- Bus pins protected against  $\pm 8$  kV HBM ESD pulses
- Bus pins protected against transients in automotive environment (according to ISO 7637 class C)
- Bus pins short-circuit proof to battery voltage (14 V and 42 V) and ground
- Fail-silent behavior in the event of an undervoltage on pins  $V_{BAT}$ ,  $V_{CC}$  or  $V_{IO}$
- Passive behavior of bus lines while the transceiver is not powered

### 2.5 Functional classes according to FlexRay electrical physical layer specification (see [Ref. 1](#))

- Bus driver voltage regulator control
- Bus driver - bus guardian control interface
- Bus driver logic level adaptation

## 3. Ordering information

Table 1. Ordering information

Type number	Package		Version
	Name	Description	
TJA1081TS	SSOP16	SSOP16: plastic shrink small outline package; 16 leads; body width 5.3 mm	SOT338-1

4. Block diagram

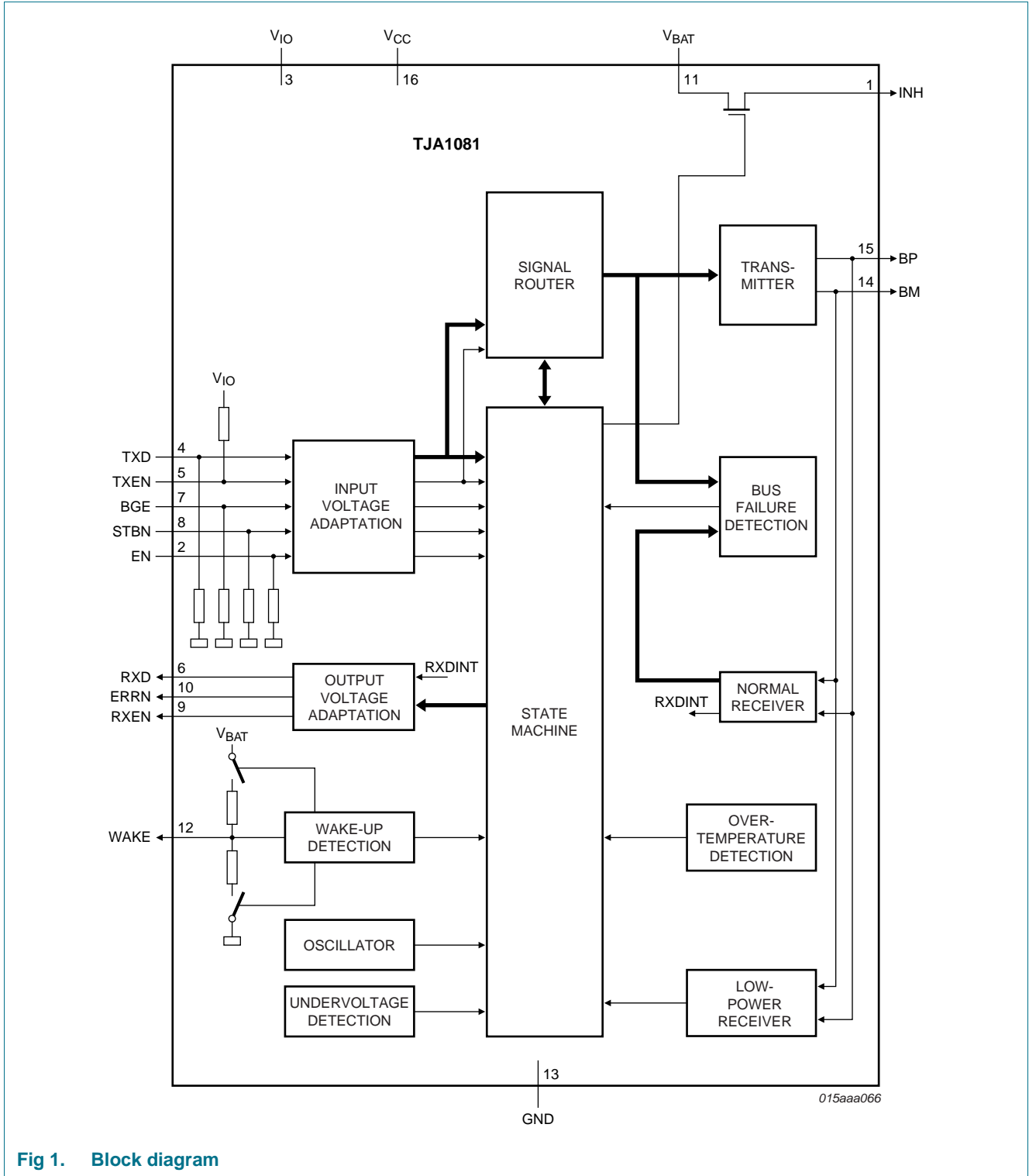
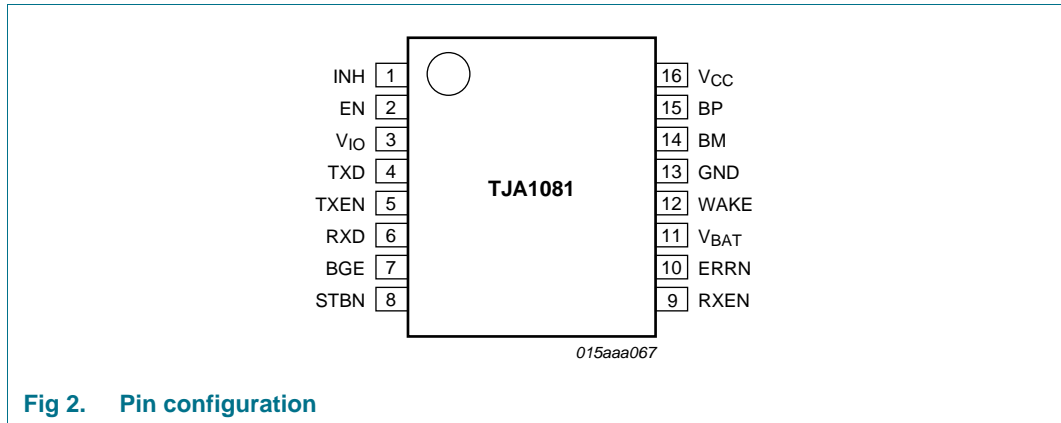

Fig 1. Block diagram

## 5. Pinning information

### 5.1 Pinning



### 5.2 Pin description

Table 2. Pin description

Symbol	Pin	Type	Description
INH	1	O	inhibit output for switching external voltage regulator
EN	2	I	enable input; enabled when HIGH; internal pull-down
V <sub>IO</sub>	3	P	supply voltage for V <sub>IO</sub> voltage level adaptation
TXD	4	I	transmit data input; internal pull-down
TXEN	5	I	transmitter enable input; when HIGH transmitter disabled; internal pull-up
RXD	6	O	receive data output
BGE	7	I	bus guardian enable input; when LOW transmitter disabled; internal pull-down
STBN	8	I	standby input; low-power mode when LOW; internal pull-down
RXEN	9	O	receive data enable output; when LOW bus activity detected
ERRN	10	O	error diagnoses output; when LOW error detected
V <sub>BAT</sub>	11	P	battery supply voltage
WAKE	12	I	local wake-up input; internal pull-up or pull-down (depends on voltage at pin WAKE)
GND	13	P	ground
BM	14	I/O	bus line minus
BP	15	I/O	bus line plus
V <sub>CC</sub>	16	P	supply voltage (+5 V)

## 6. Functional description

The block diagram of the transceiver is shown in [Figure 1](#).

### 6.1 Operating modes

The TJA1081 supports the following operating modes:

- Normal (normal-power mode)
- Receive-only (normal-power mode)
- Standby (low-power mode)
- Go-to-sleep (low-power mode)
- Sleep (low-power mode)

#### 6.1.1 Bus activity and idle detection

The following mechanisms for activity and idle detection are valid in normal-power modes:

- If the absolute differential voltage on the bus lines is higher than  $|V_{i(dif)det(act)}|$  for  $t_{det(act)(bus)}$ , activity is detected on the bus lines and pin RXEN is switched LOW which results in pin RXD being released:
  - If, after bus activity detection, the differential voltage on the bus lines is higher than  $V_{IH(dif)}$ , pin RXD will go HIGH
  - If, after bus activity detection, the differential voltage on the bus lines is lower than  $V_{iL(dif)}$ , pin RXD will go LOW
- If the absolute differential voltage on the bus lines is lower than  $|V_{i(dif)det(act)}|$  for  $t_{det(idle)(bus)}$ , then idle is detected on the bus lines and pin RXEN is switched to HIGH. This results in pin RXD being blocked (pin RXD is switched to HIGH or stays HIGH)

### 6.2 Mode control pins: STBN and EN

Control inputs STBN and EN are used to select the operating mode. See [Table 3](#) for a detailed description of pin signalling and [Figure 3](#) for the timing diagram.

All mode transitions are controlled via the STBN and EN pins, unless an undervoltage condition is detected. If  $V_{IO}$  and ( $V_{CC}$  or  $V_{BAT}$ ) are within their operating ranges, pin ERRN indicates the status of the error flag. Operating ranges are:  $V_{BAT} = 6.5\text{ V to }60\text{ V}$ ,  $V_{CC} = 4.75\text{ V to }5.25\text{ V}$  and  $V_{IO} = 2.2\text{ V to }5.25\text{ V}$ .

Table 3. Pin signalling

Mode	STBN	EN	ERRN <sup>[1]</sup>		RXEN		RXD		Transmitter	INH
			LOW	HIGH	LOW	HIGH	LOW	HIGH		
Normal	HIGH	HIGH	error flag set	error flag reset	bus activity	bus idle	bus DATA_0	bus DATA_1 or idle	enabled	HIGH
Receive-only	HIGH	LOW							disabled	
Go-to-sleep	LOW	HIGH	error flag set <sup>[2]</sup>	error flag reset	wake flag set <sup>[2]</sup>	wake flag reset	wake flag set <sup>[2]</sup>	wake flag reset		
Standby	LOW	LOW								
Sleep	LOW	X								float

[1] Pin ERRN provides a serial interface for retrieving diagnostic information.

[2] Valid if  $V_{IO}$  and ( $V_{CC}$  or  $V_{BAT}$ ) are present.

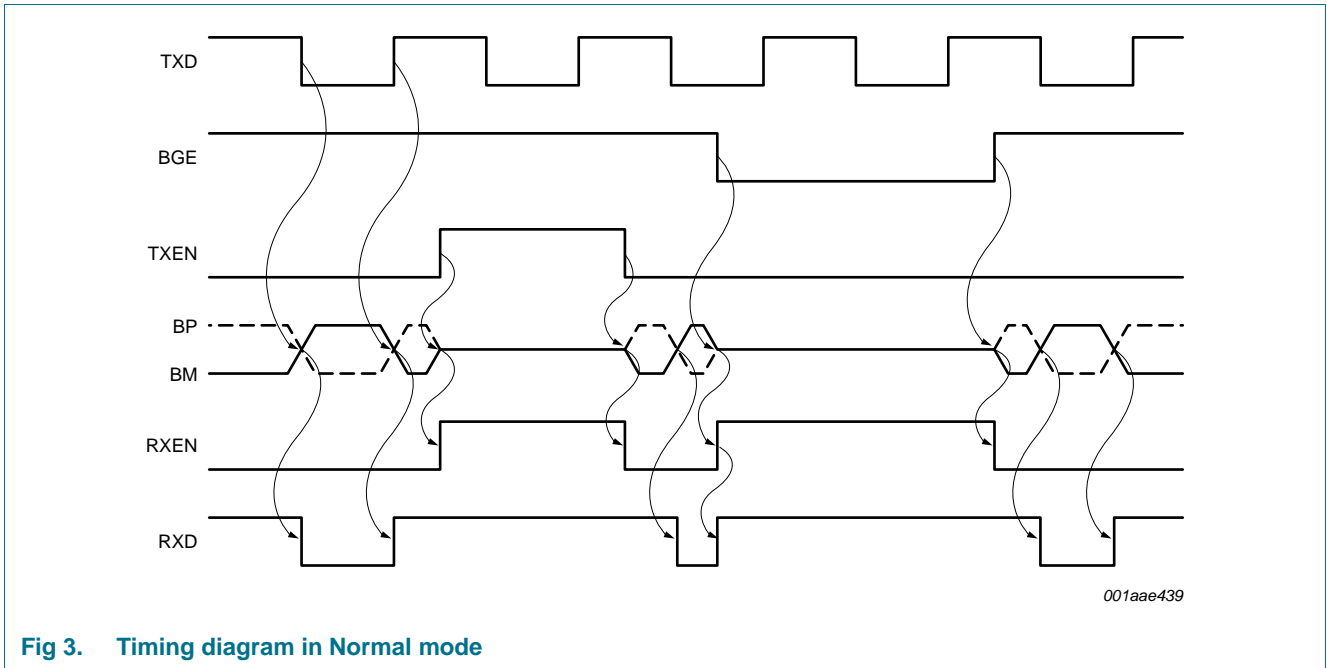

Fig 3. Timing diagram in Normal mode

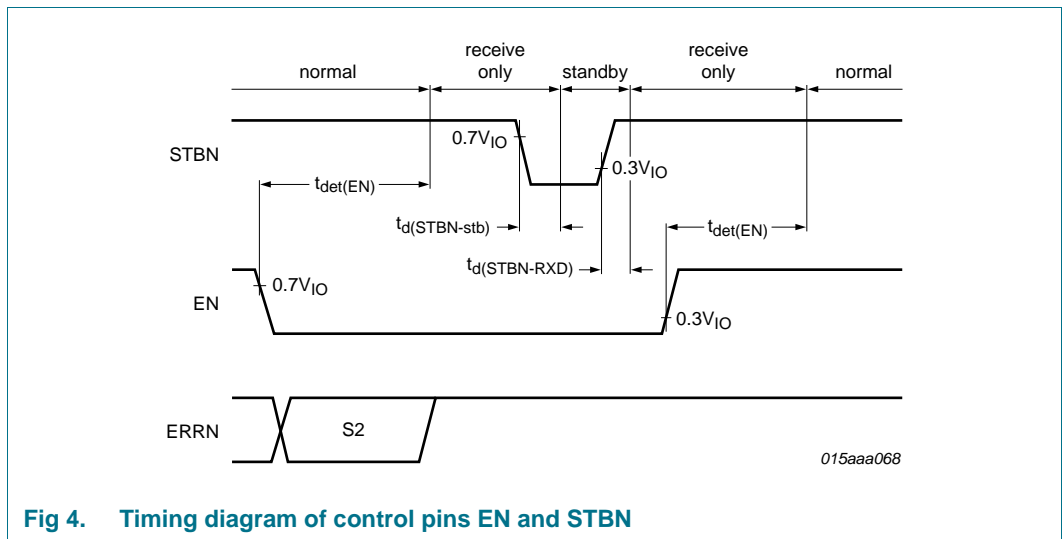
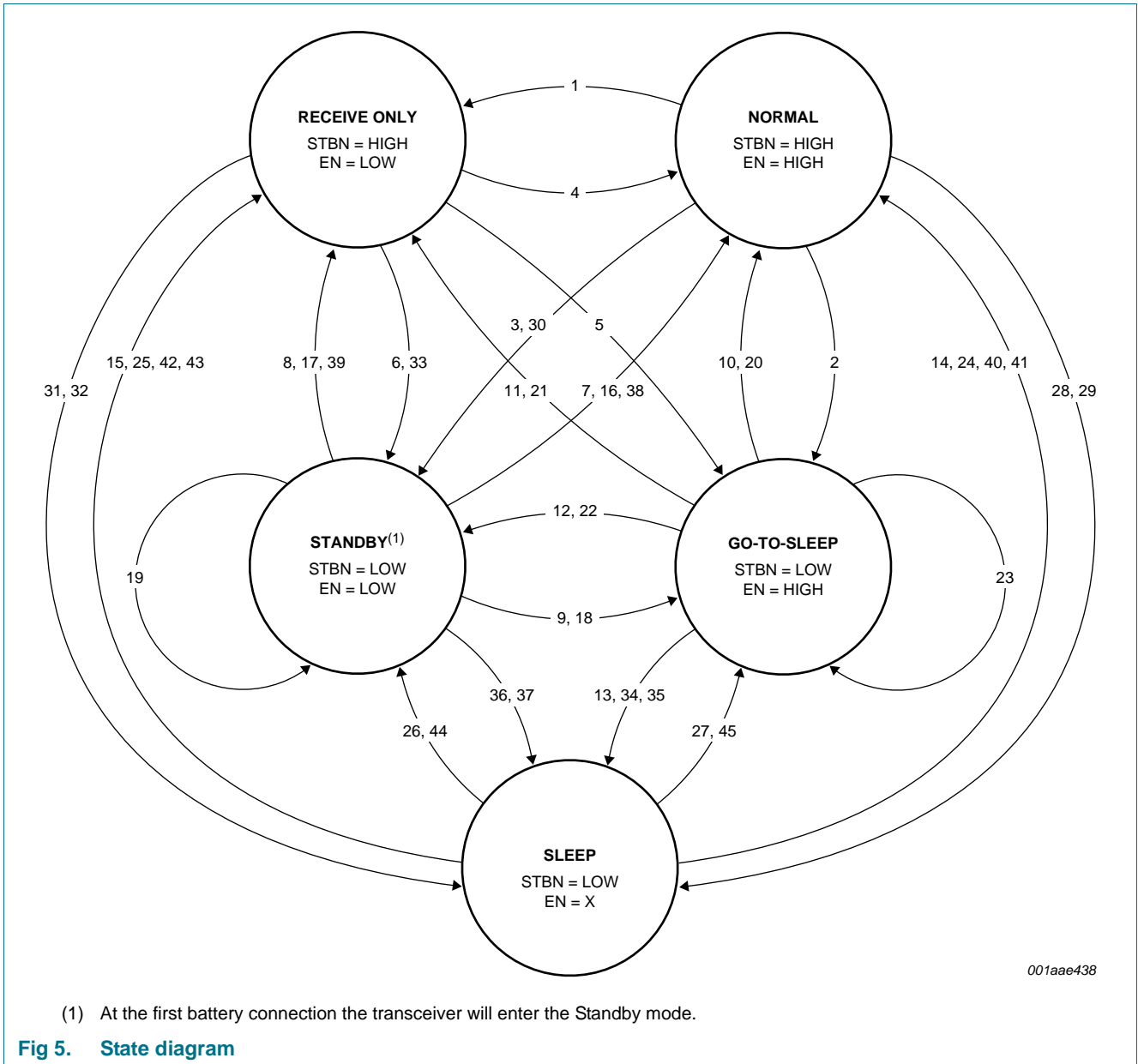

Fig 4. Timing diagram of control pins EN and STBN

The state diagram is shown in [Figure 5](#).



The state transitions are represented with numbers, which correspond with the numbers in column 3 of [Table 4](#) to [Table 7](#).

**Table 4. State transitions forced by EN and STBN**

→ indicates the action that initiates a transaction; 1 → and 2 → indicated the consequences of a transaction.

Transition from mode	Direction to mode	Transition number	Pin		Flag			
			STBN	EN	UV <sub>VIO</sub>	UV <sub>BAT</sub>	UV <sub>VCC</sub>	PWON
Normal	Receive-only	1	H	→ L	cleared	cleared	cleared	cleared
	Go-to-sleep	2	→ L	H	cleared	cleared	cleared	cleared
	Standby	3	→ L	→ L	cleared	cleared	cleared	cleared
Receive-only	Normal	4	H	→ H	cleared	cleared	cleared	X
	Go-to-sleep	5	→ L	→ H	cleared	cleared	cleared	X
	Standby	6	→ L	L	cleared	cleared	cleared	X
Standby	Normal	7	→ H	→ H	cleared	cleared	cleared	X
	Receive-only	8	→ H	L	cleared	cleared	2 → cleared	X
	Go-to-sleep	9	L	→ H	cleared	cleared	X	X
Go-to-sleep	Normal	10	→ H	H	cleared	cleared	cleared	X
	Receive-only	11	→ H	→ L	cleared	cleared	cleared	X
	Standby	12	L	→ L	cleared	cleared	X	X
Sleep	Sleep	13	L	H	cleared	cleared	X	X
	Normal	14	→ H	H	2 → cleared	2 → cleared	2 → cleared	X
	Receive-only	15	→ H	L	2 → cleared	2 → cleared	2 → cleared	X

[1] STBN must be set to LOW at least  $t_{de(EN)}$  after the falling edge on EN.

[2] Positive edge on pin STBN sets the wake flag. In the case of a transition to Normal mode the wake flag is immediately cleared.

[3] Setting the wake flag clears the UV<sub>VIO</sub>, UV<sub>BAT</sub> and UV<sub>VCC</sub> flags.

[4] Hold time of go-to-sleep is less than  $t_{h(gotosleep)}$ .

[5] Hold time of go-to-sleep becomes greater than  $t_{h(gotosleep)}$ .

**Table 5. State transitions forced by a wake-up**

→ indicates the action that initiates a transaction; 1 → and 2 → indicated the consequences of a transaction.

Transition from mode	Direction to mode	Transition number	Pin		Flag			PWON
			STBN	EN	UV_VIO	UV_VBAT	UV_VCC	
Standby	Normal	16	H	H	cleared	cleared	1 → cleared	X
	Receive-only	17	H	L	cleared	cleared	1 → cleared	X
	Go-to-sleep	18	L	H	cleared	cleared	1 → cleared	X
Go-to-sleep	Standby	19	L	L	cleared	cleared	1 → cleared	X
	Normal	20	H	H	cleared	cleared	1 → cleared	X
	Receive-only	21	H	L	cleared	cleared	1 → cleared	X
Sleep	Standby	22	L	L	cleared	cleared	1 → cleared	X
	Go-to-sleep	23	L	H	cleared	cleared	1 → cleared	X
	Normal	24	H	H	1 → cleared	1 → cleared	1 → cleared	X
Standby	Receive-only	25	H	L	1 → cleared	1 → cleared	1 → cleared	X
	Standby	26	L	L	1 → cleared	1 → cleared	1 → cleared	X
	Go-to-sleep	27	L	H	1 → cleared	1 → cleared	1 → cleared	X

[1] Setting the wake flag clears the UV\_VIO, UV\_VBAT and UV\_VCC flags.

[2] Transition via Standby mode.

**Table 6. State transitions forced by an undervoltage condition**

→ indicates the action that initiates a transaction; 1 → and 2 → indicated the consequences of a transaction.

Transition from mode	Direction to mode	Transition number	Flag			
			UV <sub>VIO</sub>	UV <sub>BAT</sub>	UV <sub>VCC</sub>	PWON
Normal	Sleep	28	→ set	cleared	cleared	cleared
	Sleep	29	cleared	→ set	cleared	cleared
	Standby	30	cleared	cleared	→ set	cleared
Receive-only	Sleep	31	→ set	cleared	cleared	X
	Sleep	32	cleared	→ set	cleared	X
	Standby	33	cleared	cleared	→ set	X
Go-to-sleep	Sleep	34	→ set	cleared	cleared	X
	Sleep	35	cleared	→ set	cleared	X
	Sleep	36	→ set	cleared	X	X
Standby	Sleep	37	cleared	→ set	X	X

[1] UV<sub>VIO</sub>, UV<sub>BAT</sub> or UV<sub>VCC</sub> detected clears the wake flag.

[2] UV<sub>VIO</sub> overrules UV<sub>VCC</sub>.

[3] UV<sub>BAT</sub> overrules UV<sub>VCC</sub>.

**Table 7. State transitions forced by an undervoltage recovery**  
 → indicates the action that initiates a transaction; →1 and →2 are the consequences of a transaction.

Transition from mode	Direction to mode	Transition number	Pin		Flag			
			STBN	EN	UV <sub>VIO</sub>	UV <sub>VBAT</sub>	UV <sub>VCC</sub>	PWON
Standby	Normal	38	H	H	cleared	cleared	→ cleared	X
	Receive-only	39	H	L	cleared	cleared	→ cleared	X
Sleep	Normal	40	H	H	cleared	→ cleared	cleared	X
	Normal	41	H	H	→ cleared	cleared	cleared	X
	Receive-only	42	H	L	cleared	→ cleared	cleared	X
	Receive-only	43	H	L	→ cleared	cleared	cleared	X
	Standby	44	L	L	cleared	→ cleared	cleared	X
	Sleep	45	L	X	→ cleared	cleared	cleared	X
	Go-to-sleep	46	L	H	cleared	→ cleared	cleared	X
Sleep	47	L	X	→ cleared	cleared	cleared	X	

[1] Recovery of UV<sub>VCC</sub> flag.

[2] Recovery of UV<sub>VBAT</sub> flag.

[3] Clearing the UV<sub>VBAT</sub> flag sets the wake flag. In the case of a transition to Normal mode the wake flag is immediately cleared.

[4] Recovery of UV<sub>VIO</sub> flag.

### 6.2.1 Normal mode

In Normal mode the transceiver is able to transmit and receive data via the bus lines BP and BM. The output of the normal receiver is directly connected to pin RXD.

Transmitter behavior in Normal mode, with no time-out present on pins TXEN and BGE and the temperature flag not set (TEMP HIGH = 0; see [Table 9](#)), is detailed in [Table 8](#).

In this mode, pin INH is set HIGH.

**Table 8. Transmitter function table**

BGE	TXEN	TXD	Transmitter
L	X	X	transmitter is disabled
X	H	X	transmitter is disabled
H	L	H	transmitter is enabled; the bus lines are actively driven; BP is driven HIGH and BM is driven LOW
H	L	L	transmitter is enabled; the bus lines are actively driven; BP is driven LOW and BM is driven HIGH

### 6.2.2 Receive-only mode

In Receive-only mode the transceiver can only receive data. The transmitter is disabled, regardless of the voltage levels on pins BGE and TXEN.

In this mode, pin INH is set HIGH.

### 6.2.3 Standby mode

Standby mode is a low-power mode featuring very low current consumption. In this mode, the transceiver cannot transmit or receive data. The low-power receiver is activated to monitor the bus for wake-up patterns.

A transition to Standby mode can be triggered by applying the appropriate levels on pins EN and STBN (see [Figure 5](#) and [Table 4](#)) or if an undervoltage is detected on pin V<sub>CC</sub> (see [Figure 5](#) and [Section 6.2.5](#)).

In this mode, pin INH is set HIGH.

If the wake flag is set, pins RXEN and RXD are driven LOW; otherwise pins RXEN and RXD are set HIGH (see [Section 6.3](#)).

### 6.2.4 Go-to-sleep mode

In this mode, the transceiver behaves as in Standby mode. If this mode is selected for a time longer than the go-to-sleep hold time ( $t_{h(\text{gotosleep})}$ ) and the wake flag has been previously cleared, the transceiver will enter Sleep mode, regardless of the voltage on pin EN.

### 6.2.5 Sleep mode

Sleep mode is a low-power mode. The only difference between Sleep mode and Standby mode is that pin INH is set floating in Sleep mode. A transition to Sleep mode will be triggered from all other modes if the UV<sub>VIO</sub> flag or the UV<sub>VBAT</sub> flag is set (see [Table 6](#)).

If an undervoltage is detected on pin V<sub>CC</sub> or V<sub>BAT</sub> while V<sub>IO</sub> is present, the wake flag is set by a positive edge on pin STBN, provided that V<sub>IO</sub> and (V<sub>CC</sub> or V<sub>BAT</sub>) are present.

The undervoltage flags will be reset when the wake flag is set, and the transceiver will enter the mode indicated by the levels on pins EN and STBN if  $V_{IO}$  is present.

### 6.3 Wake-up mechanism

From Sleep mode (pin INH is switched off), the transceiver will enter Standby or Go-to-sleep mode (depending on the level at pin EN) if the wake flag is set. Consequently, pin INH is switched on.

If an undervoltage is not detected on pins  $V_{IO}$ ,  $V_{CC}$  and  $V_{BAT}$ , the transceiver will switch immediately to the mode indicated by the levels on pins EN and STBN.

In Standby, Go-to-sleep and Sleep modes, pins RXD and RXEN are driven LOW if the wake flag is set.

#### 6.3.1 Remote wake-up

##### 6.3.1.1 Bus wake-up via wake-up pattern

Bus wake-up is detected if two consecutive DATA\_0 of at least  $t_{det(wake)DATA\_0}$  separated by an idle or DATA\_1 of at least  $t_{det(wake)idle}$ , followed by an idle or DATA\_1 of at least  $t_{det(wake)idle}$  are present on the bus lines within  $t_{det(wake)tot}$ .

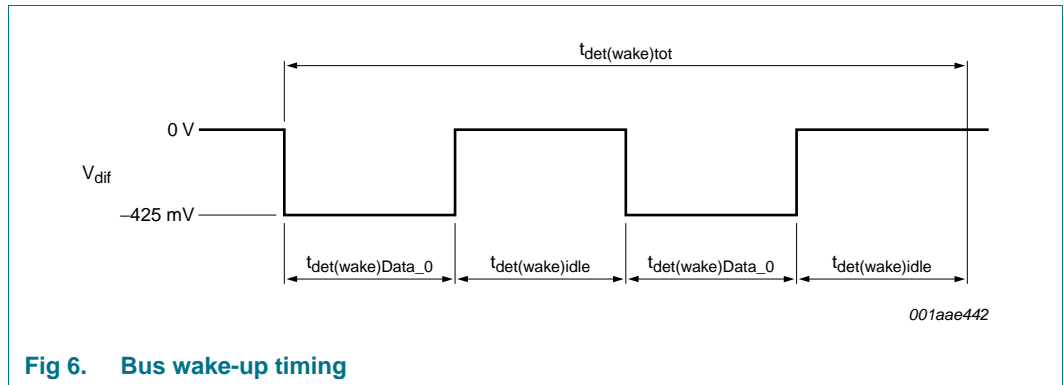

Fig 6. Bus wake-up timing

##### 6.3.1.2 Bus wake-up via dedicated FlexRay data frame

The reception of a dedicated data frame, emulating a valid wake-up pattern, as shown in [Figure 7](#), sets the wake-up flag of the TJA1081.

Due to the Byte Start Sequence (BSS), preceding each byte, the DATA\_0 and DATA\_1 phases for the wake-up symbol are interrupted every 1  $\mu$ s. For 10 Mbit/s the maximum interruption time is 130 ns. Such interruptions do not prevent the transceiver from recognizing the wake-up pattern in the payload of a data frame.

The wake-up flag will not be set if an invalid wake-up pattern is received.

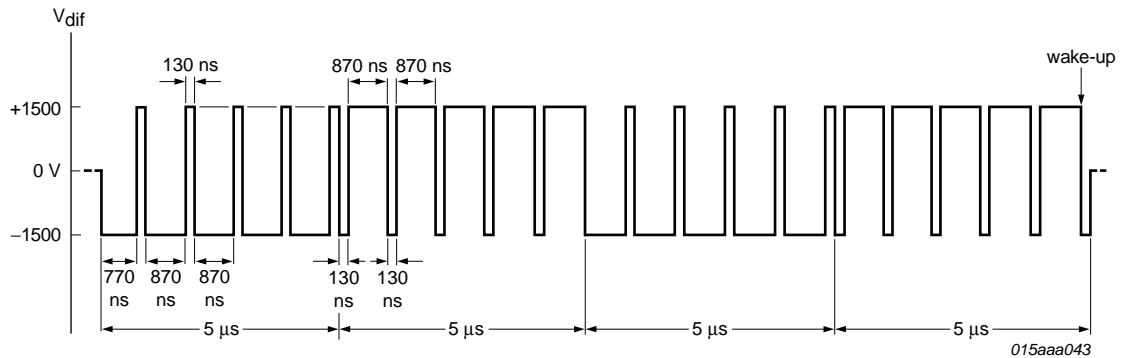

Each interruption is 130 ns.  
 The transition time from DATA\_0 to DATA\_1 and from DATA\_1 to DATA\_0 is about 20 ns.  
 The TJA1081 wake-up flag will be set with the following pattern:  
 FFh, FFh, FFh, FFh, FFh, 00h, 00h, 00h, 00h, 00h,  
 FFh, FFh, FFh, FFh, FFh, 00h, 00h, 00h, 00h, 00h,  
 FFh, FFh, FFh, FFh, FFh, 00h, 00h, 00h, 00h, 00h,  
 FFh, FFh, FFh, FFh, FFh, FFh

Fig 7. Minimum bus pattern for bus wake-up

6.3.2 Local wake-up via pin WAKE

If the voltage on pin WAKE is lower than  $V_{th(det)(WAKE)}$  for longer than  $t_{wake(WAKE)}$  (falling edge on pin WAKE) a local wake-up event on pin WAKE is detected. At the same time, the biasing of this pin is switched to pull-down.

If the voltage on pin WAKE is higher than  $V_{th(det)(WAKE)}$  for longer than  $t_{wake(WAKE)}$ , the biasing of this pin is switched to pull-up, and no local wake-up will be detected.

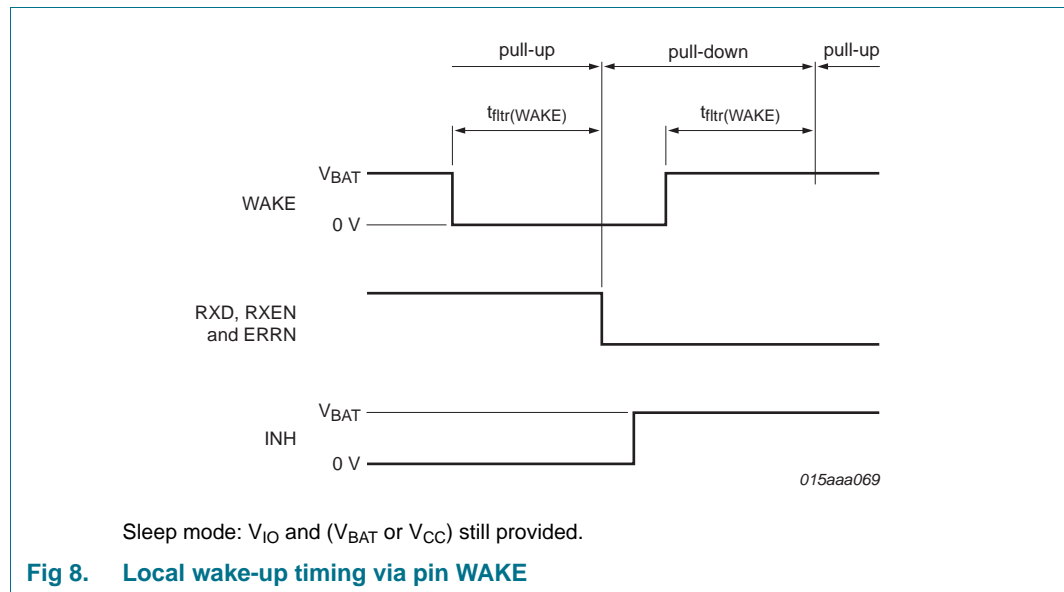

Fig 8. Local wake-up timing via pin WAKE

## 6.4 Fail-silent behavior

In order to be fail silent, undervoltage detection and a reset mechanism for the digital state machine are implemented.

If an undervoltage is detected on pins  $V_{CC}$ ,  $V_{IO}$  and/or  $V_{BAT}$ , the transceiver will enter a low-power mode. This ensures the passive and defined behavior of the transmitter and receiver when an undervoltage is detected.

In the range between the minimum operating voltage and the undervoltage detection threshold, the principle functions of the transmitter and receiver are maintained. However, in this range parameters (e.g. thresholds and delays of the transmitter and receiver) may deviate from the levels specified for the operating range.

The digital state machine is supplied by  $V_{CC}$ ,  $V_{IO}$  or  $V_{BAT}$ , depending on which voltage is available. Therefore, the digital state machine will be properly supplied as long as the voltage on pin  $V_{CC}$  or pin  $V_{IO}$  remains above 4.75 V or the voltage on pin  $V_{BAT}$  remains above 6.5 V.

If the voltage on all pins (i.e.  $V_{CC}$ ,  $V_{IO}$  and  $V_{BAT}$ ) breaks down, a reset signal will be given to the digital state machine as soon as the internal supply voltage for the digital state machine becomes too low for the proper operation of the state machine. This ensures the passive and defined behavior of the digital state machine in the event of an overall supply voltage breakdown.

### 6.4.1 $V_{BAT}$ undervoltage

If the  $UV_{V_{BAT}}$  flag is set, the transceiver will enter Sleep mode (pin INH is switched off) regardless of the voltages present on pins EN and STBN. If the undervoltage recovers, the wake flag will be set and the transceiver will enter the mode determined by the voltages on pins EN and STBN.

### 6.4.2 $V_{CC}$ undervoltage

If the  $UV_{V_{CC}}$  flag is set, the transceiver will enter Standby mode regardless of the voltages present on pins EN and STBN. If the undervoltage recovers or the wake flag is set, mode switching via pins EN and STBN is possible.

### 6.4.3 $V_{IO}$ undervoltage

If the voltage on pin  $V_{IO}$  is lower than  $V_{uvd(V_{IO})}$  (even if the  $UV_{V_{IO}}$  flag is reset) pins EN, STBN, TXD and BGE are set LOW (internally) and pin TXEN is set HIGH (internally). If the  $UV_{V_{IO}}$  flag is set, the transceiver will enter Sleep mode (pin INH is switched off). If the undervoltage recovers or the wake flag is set, mode switching via pins EN and STBN is possible.

## 6.5 Flags

### 6.5.1 Local wake-up source flag

The local wake-up source flag can only be set in a low-power mode. When a wake-up event is detected on pin WAKE (see [Section 6.3.2](#)), the local wake-up source flag is set. The local wake-up source flag is reset by entering a low-power mode.

### 6.5.2 Remote wake-up source flag

The remote wake-up source flag can only be set in a low-power mode if pin  $V_{BAT}$  is within its operating range. When a remote wake-up event is detected on the bus lines (see [Section 6.3.1](#)), the remote wake-up source flag is set. The remote wake-up source flag is reset by entering a low-power mode.

### 6.5.3 Wake flag

The wake flag is set if one of the following events occurs:

- The local or remote wake-up source flag is set (edge sensitive)
- A positive edge is detected on pin STBN when  $V_{IO}$  is present
- Recovery of the  $UV_{VBAT}$  flag

The wake flag is reset by entering Normal mode, a low-power mode or by setting one of the undervoltage flags.

### 6.5.4 Power-on flag

The PWON power-on flag is set if the internal supply voltage for the digital part becomes higher than the lowest value it needs to operate. Entering Normal mode resets the PWON flag.

### 6.5.5 Temperature medium flag

The temperature medium flag is set if the junction temperature exceeds  $T_{j(warn)(medium)}$  in a normal-power mode while pin  $V_{BAT}$  is within its operating range. The temperature medium flag is reset when the junction temperature drops below  $T_{j(warn)(medium)}$  in a normal-power mode with pin  $V_{BAT}$  within its operating range or after a read of the status register in a low-power mode while pin  $V_{BAT}$  is within its operating range. No action will be taken if this flag is set.

### 6.5.6 Temperature high flag

The temperature high flag is set if the junction temperature exceeds  $T_{j(dis)(high)}$  in a normal-power mode while pin  $V_{BAT}$  is within its operating range.

The temperature high flag is reset if a negative edge is applied to pin TXEN while the junction temperature is lower than  $T_{j(dis)(high)}$  in a normal-power mode with pin  $V_{BAT}$  within its operating range.

If the temperature high flag is set, the transmitter will be disabled.

### 6.5.7 TXEN\_BGE clamped flag

The TXEN\_BGE clamped flag is set if pin TXEN is LOW and pin BGE is HIGH for longer than  $t_{detCL}(TXEN\_BGE)$ . The TXEN\_BGE clamped flag is reset if pin TXEN is HIGH or pin BGE is LOW. If the TXEN\_BGE flag is set, the transmitter is disabled.

### 6.5.8 Bus error flag

The bus error flag is set if pin TXEN is LOW and pin BGE is HIGH and the data received from the bus lines (pins BP and BM) are different to that received on pin TXD. The transmission of any valid communication element, including a wake-up pattern, does not lead to bus error indication.

The error flag is reset if the data on the bus lines (pins BP and BM) are the same as on pin TXD or if the transmitter is disabled. No action will be taken if the bus error flag is set.

### 6.5.9 UV<sub>V<sub>BAT</sub></sub> flag

The UV<sub>V<sub>BAT</sub></sub> flag is set if the voltage on pin V<sub>BAT</sub> is lower than V<sub>uvd(V<sub>BAT</sub>)</sub>. The UV<sub>V<sub>BAT</sub></sub> flag is reset if the voltage is higher than V<sub>uvd(V<sub>BAT</sub>)</sub> or by setting the wake flag; see [Section 6.4.1](#).

### 6.5.10 UV<sub>V<sub>CC</sub></sub> flag

The UV<sub>V<sub>CC</sub></sub> flag is set if the voltage on pin V<sub>CC</sub> is lower than V<sub>uvd(V<sub>CC</sub>)</sub> for longer than t<sub>det(uv)(V<sub>CC</sub>)</sub>. The flag is reset if the voltage on pin V<sub>CC</sub> is higher than V<sub>uvd(V<sub>CC</sub>)</sub> for longer than t<sub>rec(uv)(V<sub>CC</sub>)</sub> or the wake flag is set; see [Section 6.4.2](#).

### 6.5.11 UV<sub>V<sub>IO</sub></sub> flag

The UV<sub>V<sub>IO</sub></sub> flag is set if the voltage on pin V<sub>IO</sub> is lower than V<sub>uvd(V<sub>IO</sub>)</sub> for longer than t<sub>det(uv)(V<sub>IO</sub>)</sub>. The flag is reset if the voltage on pin V<sub>IO</sub> is higher than V<sub>uvd(V<sub>IO</sub>)</sub> or the wake flag is set; see [Section 6.4.3](#).

### 6.5.12 Error flag

The error flag is set if one of the status bits S4 to S10 is set. The error flag is reset if none of the S4 to S10 status bits are set; see [Table 9](#).

## 6.6 Status register

The status register can be read out on pin ERRN by using pin EN as clock; the status bits are given in [Table 9](#). The timing diagram is shown in [Figure 9](#).

The status register is accessible if:

- UV<sub>V<sub>IO</sub></sub> flag is not set and the voltage on pin V<sub>IO</sub> is between 4.75 V and 5.25 V
- UV<sub>V<sub>CC</sub></sub> flag is not set and the voltage on pin V<sub>IO</sub> is between 2.2 V and 4.75 V

After reading the status register, if no edge is detected on pin EN for longer than t<sub>det(EN)</sub>, the status bits (S4 to S12) will be cleared if the corresponding flag has been reset. Pin ERRN is LOW if the corresponding status bit is set.

**Table 9.** Status bits

Bit number	Status bit	Description
S0	LOCAL WAKEUP	local wake-up source flag is redirected to this bit
S1	REMOTE WAKEUP	remote wake-up source flag is redirected to this bit
S2	-	not used; always set
S3	PWON	status bit set means PWON flag has been set previously
S4	BUS ERROR	status bit set means bus error flag has been set previously
S5	TEMP HIGH	status bit set means temperature high flag has been set previously
S6	TEMP MEDIUM	status bit set means temperature medium flag has been set previously
S7	TXEN_BGE CLAMPED	status bit set means TXEN_BGE clamped flag has been set previously
S8	UV <sub>V<sub>BAT</sub></sub>	status bit set means UV <sub>V<sub>BAT</sub></sub> flag has been set previously
S9	UV <sub>V<sub>CC</sub></sub>	status bit set means UV <sub>V<sub>CC</sub></sub> flag has been set previously

Table 9. Status bits ...continued

Bit number	Status bit	Description
S10	UVVIO	status bit set means $UV_{VIO}$ flag has been set previously
S11	-	not used; always reset
S12	-	not used; always reset

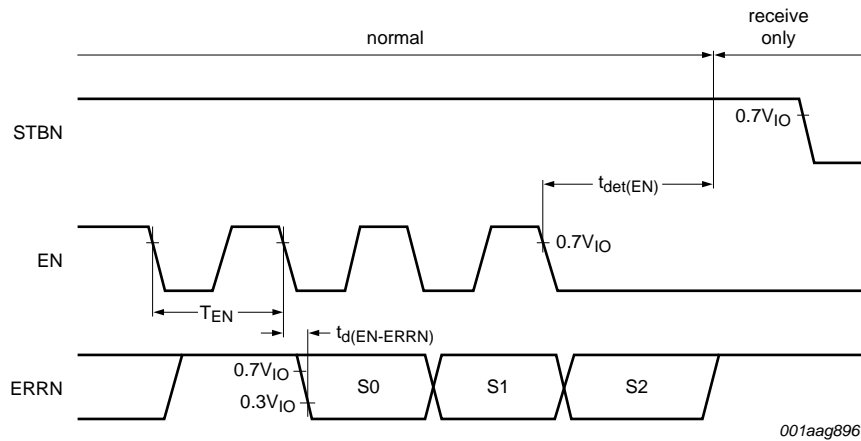

Fig 9. Timing diagram for status bits

## 7. Limiting values

**Table 10. Limiting values**

In accordance with the Absolute Maximum Rating System (IEC 60134). All voltages are referenced to GND.

Symbol	Parameter	Conditions	Min	Max	Unit
V <sub>BAT</sub>	battery supply voltage	no time limit	-0.3	+60	V
V <sub>CC</sub>	supply voltage	no time limit	-0.3	+5.5	V
V <sub>IO</sub>	supply voltage on pin V <sub>IO</sub>	no time limit	-0.3	+5.5	V
V <sub>INH</sub>	voltage on pin INH		-0.3	V <sub>BAT</sub> + 0.3	V
I <sub>O(INH)</sub>	output current on pin INH	no time limit	-1	-	mA
V <sub>WAKE</sub>	voltage on pin WAKE		-0.3	V <sub>BAT</sub> + 0.3	V
I <sub>O(WAKE)</sub>	output current on pin WAKE	pin GND not connected	-15	-	mA
V <sub>BGE</sub>	voltage on pin BGE	no time limit	-0.3	+5.5	V
V <sub>TXEN</sub>	voltage on pin TXEN	no time limit	-0.3	+5.5	V
V <sub>TXD</sub>	voltage on pin TXD	no time limit	-0.3	+5.5	V
V <sub>ERRN</sub>	voltage on pin ERRN	no time limit	-0.3	V <sub>IO</sub> + 0.3	V
V <sub>RXD</sub>	voltage on pin RXD	no time limit	-0.3	V <sub>IO</sub> + 0.3	V
V <sub>RXEN</sub>	voltage on pin RXEN	no time limit	-0.3	V <sub>IO</sub> + 0.3	V
V <sub>EN</sub>	voltage on pin EN	no time limit	-0.3	+5.5	V
V <sub>STBN</sub>	voltage on pin STBN	no time limit	-0.3	+5.5	V
V <sub>BP</sub>	voltage on pin BP	no time limit	-60	+60	V
V <sub>BM</sub>	voltage on pin BM	no time limit	-60	+60	V
V <sub>trt</sub>	transient voltage	on pins BM and BP	[1] -100 [2] - [3] -150 [4] -	- 75 - 100	V V V V
T <sub>stg</sub>	storage temperature		-55	+150	°C
T <sub>vj</sub>	virtual junction temperature		[5] -40	+150	°C
V <sub>ESD</sub>	electrostatic discharge voltage	HBM on pins BP and BM to ground	[6] -8.0	+8.0	kV
		HBM at any other pin	[6] -4.0	+4.0	kV
		MM on all pins	[7] -200	+200	V
		CDM on all pins	[8] -1000	+1000	V

[1] According to ISO7637, test pulse 1, class C; verified by an external test house.

[2] According to ISO7637, test pulse 2a, class C; verified by an external test house.

[3] According to ISO7637, test pulse 3a, class C; verified by an external test house.

[4] According to ISO7637, test pulse 3b, class C; verified by an external test house.

[5] In accordance with IEC 60747-1. An alternative definition of T<sub>vj</sub> is: T<sub>vj</sub> = T<sub>amb</sub> + P × R<sub>th(j-a)</sub>, where R<sub>th(j-a)</sub> is a fixed value to be used for the calculation of T<sub>vj</sub>. The rating for T<sub>vj</sub> limits the allowable combinations of power dissipation (P) and ambient temperature (T<sub>amb</sub>).

[6] HBM: C = 100 pF; R = 1.5 kΩ.

[7] MM: C = 200 pF; L = 0.75 μH; R = 10 Ω.

[8] CDM: R = 1 Ω.

## 8. Thermal characteristics

Table 11. Thermal characteristics

Symbol	Parameter	Conditions	Typ	Unit
$R_{th(j-a)}$	thermal resistance from junction to ambient	in free air	118	K/W

## 9. Static characteristics

Table 12. Static characteristics

All parameters are guaranteed for  $V_{BAT} = 6.5\text{ V to }60\text{ V}$ ;  $V_{CC} = 4.75\text{ V to }5.25\text{ V}$ ;  $V_{IO} = 2.2\text{ V to }5.25\text{ V}$ ;  $T_{vj} = -40\text{ °C to }+150\text{ °C}$ ;  $R_{bus} = 45\ \Omega$  unless otherwise specified. All voltages are defined with respect to ground; positive currents flow into the IC.

Symbol	Parameter	Conditions	Min	Typ	Max	Unit
<b>Pin <math>V_{BAT}</math></b>						
$I_{BAT}$	battery supply current	low-power modes; no load on pin INH	-	-	55	$\mu\text{A}$
		normal-power modes	-	-	1	$\text{mA}$
$V_{uvd(VBAT)}$	undervoltage detection voltage on pin $V_{BAT}$		2.75	-	4.5	V
<b>Pin <math>V_{CC}</math></b>						
$I_{CC}$	supply current	low-power modes	-1	0	+10	$\mu\text{A}$
		Normal mode; $V_{BGE} = 0\text{ V}$ ; $V_{TXEN} = V_{IO}$ ; Receive-only mode	-	-	15	$\text{mA}$
		Normal mode; $V_{BGE} = V_{IO}$ ; $V_{TXEN} = 0\text{ V}$	-	-	37	$\text{mA}$
		Normal mode; $V_{BGE} = V_{IO}$ ; $V_{TXEN} = 0\text{ V}$ ; $R_{bus} = \infty\ \Omega$	-	-	15	$\text{mA}$
$V_{uvd(VCC)}$	undervoltage detection voltage on pin $V_{CC}$	$(V_{BAT} \geq 5.5\text{ V AND } V_{IO} \geq 4.75\text{ V})\text{ OR } V_{BAT} \geq 6.5\text{ V}$	2.75	3.7	4.5	V
<b>Pin <math>V_{IO}</math></b>						
$I_{IO}$	supply current on pin $V_{IO}$	low-power modes	-1	+1	+10	$\mu\text{A}$
		Normal and Receive-only modes; $V_{TXD} = V_{IO}$	-	-	1000	$\mu\text{A}$
$V_{uvd(VIO)}$	undervoltage detection voltage on pin $V_{IO}$		1	1.5	2	V
$V_{uvr(VIO)}$	undervoltage recovery voltage on pin $V_{IO}$		1	1.6	2.2	V
$V_{uvhys(VIO)}$	undervoltage hysteresis voltage on pin $V_{IO}$	$V_{BAT} > 5.5\text{ V}$	25	-	200	$\text{mV}$
<b>Pin EN</b>						
$V_{IH(EN)}$	HIGH-level input voltage on pin EN		$0.7V_{IO}$	-	5.5	V
$V_{IL(EN)}$	LOW-level input voltage on pin EN		-0.3	-	$0.3V_{IO}$	V
$I_{IH(EN)}$	HIGH-level input current on pin EN	$V_{EN} = 0.7V_{IO}$	3	-	11	$\mu\text{A}$
$I_{IL(EN)}$	LOW-level input current on pin EN	$V_{EN} = 0\text{ V}$	-1	0	+1	$\mu\text{A}$
<b>Pin STBN</b>						
$V_{IH(STBN)}$	HIGH-level input voltage on pin STBN		$0.7V_{IO}$	-	5.5	V

**Table 12. Static characteristics ...continued**

All parameters are guaranteed for  $V_{BAT} = 6.5\text{ V to }60\text{ V}$ ;  $V_{CC} = 4.75\text{ V to }5.25\text{ V}$ ;  $V_{IO} = 2.2\text{ V to }5.25\text{ V}$ ;  $T_{vj} = -40\text{ }^{\circ}\text{C to }+150\text{ }^{\circ}\text{C}$ ;  $R_{bus} = 45\text{ }\Omega$  unless otherwise specified. All voltages are defined with respect to ground; positive currents flow into the IC.

Symbol	Parameter	Conditions	Min	Typ	Max	Unit
$V_{IL(STBN)}$	LOW-level input voltage on pin STBN		-0.3	-	$0.3V_{IO}$	V
$I_{IH(STBN)}$	HIGH-level input current on pin STBN	$V_{STBN} = 0.7V_{IO}$	3	-	11	$\mu\text{A}$
$I_{IL(STBN)}$	LOW-level input current on pin STBN	$V_{STBN} = 0\text{ V}$	-1	0	+1	$\mu\text{A}$
<b>Pin TXEN</b>						
$V_{IH(TXEN)}$	HIGH-level input voltage on pin TXEN		$0.7V_{IO}$	-	5.5	V
$V_{IL(TXEN)}$	LOW-level input voltage on pin TXEN		-0.3	-	$0.3V_{IO}$	V
$I_{IH(TXEN)}$	HIGH-level input current on pin TXEN	$V_{TXEN} = V_{IO}$	-1	0	+1	$\mu\text{A}$
$I_{IL(TXEN)}$	LOW-level input current on pin TXEN	$V_{TXEN} = 0.3V_{IO}$	-15	-	-3	$\mu\text{A}$
$I_{L(TXEN)}$	leakage current on pin TXEN	$V_{TXEN} = 5.25\text{ V}; V_{IO} = 0\text{ V}$	-1	0	+1	$\mu\text{A}$
<b>Pin BGE</b>						
$V_{IH(BGE)}$	HIGH-level input voltage on pin BGE		$0.7V_{IO}$	-	5.5	V
$V_{IL(BGE)}$	LOW-level input voltage on pin BGE		-0.3	-	$0.3V_{IO}$	V
$I_{IH(BGE)}$	HIGH-level input current on pin BGE	$V_{BGE} = 0.7V_{IO}$	3	-	11	$\mu\text{A}$
$I_{IL(BGE)}$	LOW-level input current on pin BGE	$V_{BGE} = 0\text{ V}$	-1	0	+1	$\mu\text{A}$
<b>Pin TXD</b>						
$V_{IH(TXD)}$	HIGH-level input voltage on pin TXD	normal-power modes	$0.7V_{IO}$	-	$V_{IO} + 0.3$	V
$V_{IL(TXD)}$	LOW-level input voltage on pin TXD	normal-power modes	-0.3	-	$0.3V_{IO}$	V
$I_{IH(TXD)}$	HIGH-level input current on pin TXD	$V_{TXD} = V_{IO}$	70	230	650	$\mu\text{A}$
$I_{IL(TXD)}$	LOW-level input current on pin TXD	normal-power modes; $V_{TXD} = 0\text{ V}$	-5	0	+5	$\mu\text{A}$
		low-power modes	-1	0	+1	$\mu\text{A}$
$I_{LI(TXD)}$	input leakage current on pin TXD	$V_{TXD} = 5.25\text{ V}; V_{IO} = 0\text{ V}$	-1	0	+1	$\mu\text{A}$
$C_{i(TXD)}$	input capacitance on pin TXD	not tested; with respect to <a href="#">[1]</a> all other pins at ground; $V_{TXD} = 100\text{ mV}; f = 5\text{ MHz}$	-	5	10	pF
<b>Pin RXD</b>						
$I_{OH(RXD)}$	HIGH-level output current on pin RXD	$V_{RXD} = V_{IO} - 0.4\text{ V};$ $V_{IO} = V_{CC}$	-20	-	-2	mA
$I_{OL(RXD)}$	LOW-level output current on pin RXD	$V_{RXD} = 0.4\text{ V}$	2	-	20	mA
<b>Pin ERRN</b>						
$I_{OH(ERRN)}$	HIGH-level output current on pin ERRN	$V_{ERRN} = V_{IO} - 0.4\text{ V};$ $V_{IO} = V_{CC}$	-1500	-600	-100	$\mu\text{A}$
$I_{OL(ERRN)}$	LOW-level output current on pin ERRN	$V_{ERRN} = 0.4\text{ V}$	300	700	1500	$\mu\text{A}$
<b>Pin RXEN</b>						
$I_{OH(RXEN)}$	HIGH-level output current on pin RXEN	$V_{RXEN} = V_{IO} - 0.4\text{ V};$ $V_{IO} = V_{CC}$	-4	-1.7	-0.5	mA
$I_{OL(RXEN)}$	LOW-level output current on pin RXEN	$V_{RXEN} = 0.4\text{ V}$	1	3.2	8	mA

**Table 12. Static characteristics ...continued**

All parameters are guaranteed for  $V_{BAT} = 6.5\text{ V to }60\text{ V}$ ;  $V_{CC} = 4.75\text{ V to }5.25\text{ V}$ ;  $V_{IO} = 2.2\text{ V to }5.25\text{ V}$ ;  $T_{vj} = -40\text{ }^{\circ}\text{C to }+150\text{ }^{\circ}\text{C}$ ;  $R_{bus} = 45\text{ }\Omega$  unless otherwise specified. All voltages are defined with respect to ground; positive currents flow into the IC.

Symbol	Parameter	Conditions	Min	Typ	Max	Unit
<b>Pins BP and BM</b>						
$V_{o(idle)(BP)}$	idle output voltage on pin BP	Normal or Receive-only mode; $V_{TXEN} = V_{IO}$	$0.4V_{CC}$	$0.5V_{CC}$	$0.6V_{CC}$	V
		Standby, Go-to-sleep or Sleep mode	-0.1	0	+0.1	V
$V_{o(idle)(BM)}$	idle output voltage on pin BM	Normal or Receive-only mode; $V_{TXEN} = V_{IO}$	$0.4V_{CC}$	$0.5V_{CC}$	$0.6V_{CC}$	V
		Standby, Go-to-sleep or Sleep mode	-0.1	0	+0.1	V
$I_{o(idle)BP}$	idle output current on pin BP	$-60\text{ V} \leq V_{BP} \leq +60\text{ V}$ ; with respect to GND and $V_{BAT}$	-7.5	-	+7.5	mA
$I_{o(idle)BM}$	idle output current on pin BM	$-60\text{ V} \leq V_{BM} \leq +60\text{ V}$ ; with respect to GND and $V_{BAT}$	-7.5	-	+7.5	mA
$V_{o(idle)(dif)}$	differential idle output voltage		-25	0	+25	mV
$V_{OH(dif)}$	differential HIGH-level output voltage	$40\text{ }\Omega \leq R_{bus} \leq 55\text{ }\Omega$ ; $V_{CC} = 5\text{ V}$ ; $C_{bus} = 100\text{ pF}$	600	850	1500	mV
$V_{OL(dif)}$	differential LOW-level output voltage	$40\text{ }\Omega \leq R_{bus} \leq 55\text{ }\Omega$ ; $V_{CC} = 5\text{ V}$ ; $C_{bus} = 100\text{ pF}$	-1500	-850	-600	mV
$V_{IH(dif)}$	differential HIGH-level input voltage	normal-power modes; $-10\text{ V} \leq V_{BP} \leq +15\text{ V}$ ; $-10\text{ V} \leq V_{BM} \leq +15\text{ V}$	150	210	300	mV
$V_{IL(dif)}$	differential LOW-level input voltage	normal-power modes; $-10\text{ V} \leq V_{BP} \leq +15\text{ V}$ ; $-10\text{ V} \leq V_{BM} \leq +15\text{ V}$	-300	-210	-150	mV
		low-power modes; $-10\text{ V} \leq V_{BP} \leq +15\text{ V}$ ; $-10\text{ V} \leq V_{BM} \leq +15\text{ V}$	-400	-210	-100	mV
$ \Delta V_{i(dif)(H-L)} $	differential input volt. diff. betw. HIGH- and LOW-levels (abs. value)	normal-power modes; $(V_{BP} + V_{BM}) / 2 = 2.5\text{ V}$	-	-	10	%
$ V_{i(dif)det(act)} $	activity detection differential input voltage (absolute value)	normal-power modes	150	210	300	mV
$ I_{O(sc)} $	short-circuit output current (absolute value)	on pin BP; $0\text{ V} \leq V_{BP} \leq 60\text{ V}$	-	-	35	mA
		on pin BM; $0\text{ V} \leq V_{BM} \leq 60\text{ V}$	-	-	35	mA
		on pins BP and BM; $V_{BP} = V_{BM}$ ; $0\text{ V} \leq V_{BP} \leq 60\text{ V}$ ; $0\text{ V} \leq V_{BM} \leq 60\text{ V}$	-	-	35	mA
$R_{i(BP)}$	input resistance on pin BP	idle level; $R_{bus} = \infty\text{ }\Omega$	10	18.5	40	k $\Omega$
$R_{i(BM)}$	input resistance on pin BM	idle level; $R_{bus} = \infty\text{ }\Omega$	10	18.5	40	k $\Omega$
$R_{i(dif)(BP-BM)}$	differential input resistance between pin BP and pin BM	idle level; $R_{bus} = \infty\text{ }\Omega$	20	37	80	k $\Omega$
$I_{LI(BP)}$	input leakage current on pin BP	$V_{BP} = 5\text{ V}$ ; $V_{BAT} = V_{CC} = V_{IO} = 0\text{ V}$	-10	0	+10	$\mu\text{A}$

**Table 12. Static characteristics ...continued**

All parameters are guaranteed for  $V_{BAT} = 6.5\text{ V to }60\text{ V}$ ;  $V_{CC} = 4.75\text{ V to }5.25\text{ V}$ ;  $V_{IO} = 2.2\text{ V to }5.25\text{ V}$ ;  $T_{vj} = -40\text{ °C to }+150\text{ °C}$ ;  $R_{bus} = 45\ \Omega$  unless otherwise specified. All voltages are defined with respect to ground; positive currents flow into the IC.

Symbol	Parameter	Conditions	Min	Typ	Max	Unit
$I_{L(BM)}$	input leakage current on pin BM	$V_{BM} = 5\text{ V}$ ; $V_{BAT} = V_{CC} = V_{IO} = 0\text{ V}$	-10	0	+10	$\mu\text{A}$
$V_{cm(bus)(DATA_0)}$	DATA_0 bus common-mode voltage	$R_{bus} = 45\ \Omega$	$0.4V_{CC}$	$0.5V_{CC}$	$0.6V_{CC}$	V
$V_{cm(bus)(DATA_1)}$	DATA_1 bus common-mode voltage	$R_{bus} = 45\ \Omega$	$0.4V_{CC}$	$0.5V_{CC}$	$0.6V_{CC}$	V
$\Delta V_{cm(bus)}$	bus common-mode voltage difference	$R_{bus} = 45\ \Omega$	-25	0	+25	mV
$C_{i(BP)}$	input capacitance on pin BP	not tested; with respect to all other pins at ground; $V_{BP} = 100\text{ mV}$ ; $f = 5\text{ MHz}$	[1] -	8	15	pF
$C_{i(BM)}$	input capacitance on pin BM	not tested; with respect to all other pins at ground; $V_{BM} = 100\text{ mV}$ ; $f = 5\text{ MHz}$	[1] -	8	15	pF
$C_{i(dif)(BP-BM)}$	differential input capacitance between pin BP and pin BM	not tested; with respect to all other pins at ground; $V_{(BM-BP)} = 100\text{ mV}$ ; $f = 5\text{ MHz}$	[1] -	2	5	pF
<b>Pin INH</b>						
$V_{OH(INH)}$	HIGH-level output voltage on pin INH	$I_{INH} = -0.2\text{ mA}$	$V_{BAT} - 0.8$	$V_{BAT} - 0.3$	$V_{BAT} - 0.1$	V
$I_{L(INH)}$	leakage current on pin INH	Sleep mode	-5	0	+5	$\mu\text{A}$
$I_{OL(INH)}$	LOW-level output current on pin INH	$V_{INH} = 0\text{ V}$	-15	-5	-1	mA
<b>Pin WAKE</b>						
$V_{th(det)(WAKE)}$	detection threshold voltage on pin WAKE	low-power mode	2.5	-	4.5	V
$I_{IL(WAKE)}$	LOW-level input current on pin WAKE	$V_{WAKE} = 2.4\text{ V}$ for $t > t_{wake(WAKE)}$	3	-	11	$\mu\text{A}$
$I_{IH(WAKE)}$	HIGH-level input current on pin WAKE	$V_{WAKE} = 4.6\text{ V}$ for $t > t_{wake(WAKE)}$	-11	-	-3	$\mu\text{A}$
<b>Temperature protection</b>						
$T_{j(warn)(medium)}$	medium warning junction temperature	$V_{BAT} > 5.5\text{ V}$	155	165	175	$^{\circ}\text{C}$
$T_{j(dis)(high)}$	high disable junction temperature	$V_{BAT} > 5.5\text{ V}$	180	190	200	$^{\circ}\text{C}$
<b>Power-on reset</b>						
$V_{th(det)POR}$	power-on reset detection threshold voltage		3.0	-	3.4	V
$V_{th(rec)POR}$	power-on reset recovery threshold voltage		3.1	-	3.5	V
$V_{hys(POR)}$	power-on reset hysteresis voltage		100	-	200	mV

[1] These values are based on measurements taken on several samples (less than 10 pieces). These measurements have taken place in the laboratory and have been done at  $T_{amb} = 25\text{ °C}$  and  $T_{amb} = 125\text{ °C}$ . No characterization has been done for these parameters. No industrial test will be performed on production products.

## 10. Dynamic characteristics

**Table 13. Dynamic characteristics**

All parameters are guaranteed for  $V_{BAT} = 6.5\text{ V to }60\text{ V}$ ;  $V_{CC} = 4.75\text{ V to }5.25\text{ V}$ ;  $V_{IO} = 2.2\text{ V to }5.25\text{ V}$ ;  $T_{vj} = -40\text{ }^{\circ}\text{C to }+150\text{ }^{\circ}\text{C}$ ;  $R_{bus} = 45\ \Omega$  unless otherwise specified. All voltages are defined with respect to ground; positive currents flow into the IC.

Symbol	Parameter	Conditions	Min	Typ	Max	Unit
<b>Pins BP and BM</b>						
$t_{d(TXD-bus)}$	delay time from TXD to bus	Normal mode	[1]			
		DATA_0	-	-	50	ns
		DATA_1	-	-	50	ns
$\Delta t_{d(TXD-bus)}$	delay time difference from TXD to bus	Normal mode; between DATA_0 and DATA_1	[1]	-	4	ns
$t_{d(bus-RXD)}$	delay time from bus to RXD	Normal mode; $C_{RXD} = 15\text{ pF}$ ; see <a href="#">Figure 11</a>				
		DATA_0	-	-	50	ns
		DATA_1	-	-	50	ns
$\Delta t_{d(bus-RXD)}$	delay time difference from bus to RXD	Normal mode $C_{RXD} = 15\text{ pF}$ ; between DATA_0 and DATA_1; see <a href="#">Figure 11</a>	-	-	5	ns
$t_{d(TXEN-busidle)}$	delay time from TXEN to bus idle	Normal mode	-	46	80	ns
$t_{d(TXEN-busact)}$	delay time from TXEN to bus active	Normal mode	-	39	75	ns
$t_{d(BGE-busidle)}$	delay time from BGE to bus idle	Normal mode	-	47	100	ns
$t_{d(BGE-busact)}$	delay time from BGE to bus active	Normal mode	-	40	75	ns
$t_{d(bus)(idle-act)}$	bus delay time from idle to active	Normal mode	-	7	30	ns
$t_{d(bus)(act-idle)}$	bus delay time from active to idle	Normal mode	-	7	30	ns
$t_{r(dif)(bus)}$	bus differential rise time	10 % to 90 %; $R_{bus} = 45\ \Omega$ ; $C_{bus} = 100\text{ pF}$	5	17	25	ns
$t_{f(dif)(bus)}$	bus differential fall time	90 % to 10 %; $R_{bus} = 45\ \Omega$ ; $C_{bus} = 100\text{ pF}$	5	17	25	ns
<b>WAKE symbol detection</b>						
$t_{det(wake)DATA\_0}$	DATA_0 wake-up detection time	Standby or Sleep mode;	1	-	4	$\mu\text{s}$
$t_{det(wake)idle}$	idle wake-up detection time	$-10\text{ V} \leq V_{BP} \leq +15\text{ V}$ ; $-10\text{ V} \leq V_{BM} \leq +15\text{ V}$	1	-	4	$\mu\text{s}$
$t_{det(wake)tot}$	total wake-up detection time		50	-	115	$\mu\text{s}$
<b>Undervoltage</b>						
$t_{det(uv)(VCC)}$	undervoltage detection time on pin $V_{CC}$		100	-	670	ms
$t_{rec(uv)(VCC)}$	undervoltage recovery time on pin $V_{CC}$		1	-	5.2	ms
$t_{det(uv)(VIO)}$	undervoltage detection time on pin $V_{IO}$		100	-	670	ms
$t_{det(uv)(VBAT)}$	undervoltage detection time on pin $V_{BAT}$		-	-	1	ms
<b>Activity detection</b>						
$t_{det(act)(bus)}$	activity detection time on bus pins	$V_{dif}$ : 0 mV $\rightarrow$ 400 mV	100	-	250	ns
$t_{det(idle)(bus)}$	idle detection time on bus pins	$V_{dif}$ : 400 mV $\rightarrow$ 0 mV	100	-	245	ns
<b>Mode control pins</b>						
$t_{d(STBN-RXD)}$	STBN to RXD delay time	STBN HIGH to RXD HIGH; wake flag set	-	-	2	$\mu\text{s}$

**Table 13. Dynamic characteristics ...continued**

All parameters are guaranteed for  $V_{BAT} = 6.5\text{ V to }60\text{ V}$ ;  $V_{CC} = 4.75\text{ V to }5.25\text{ V}$ ;  $V_{IO} = 2.2\text{ V to }5.25\text{ V}$ ;  $T_{vj} = -40\text{ }^{\circ}\text{C to }+150\text{ }^{\circ}\text{C}$ ;  $R_{bus} = 45\ \Omega$  unless otherwise specified. All voltages are defined with respect to ground; positive currents flow into the IC.

Symbol	Parameter	Conditions	Min	Typ	Max	Unit
$t_{d(STBN-stb)}$	delay time from STBN to standby mode	STBN LOW to Standby mode; Receive-only mode <sup>[2]</sup>	-	-	10	$\mu\text{s}$
$t_{h(gotosleep)}$	go-to-sleep hold time		20	35	50	$\mu\text{s}$
<b>Status register</b>						
$t_{det(EN)}$	detection time on pin EN	for mode control	20	-	80	$\mu\text{s}$
$T_{EN}$	time period on pin EN	for reading status bits	4	-	20	$\mu\text{s}$
$t_{d(EN-ERRN)}$	delay time from EN to ERRN	for reading status bits	-	-	2	$\mu\text{s}$
<b>WAKE</b>						
$t_{wake(WAKE)}$	wake-up time on pin WAKE	low-power modes; falling edge on pin WAKE; $6.5\text{ V} \leq V_{BAT} \leq 27\text{ V}$	5	28	100	$\mu\text{s}$
		low-power modes; falling edge on pin WAKE; $27\text{ V} < V_{BAT} \leq 60\text{ V}$	25	75	175	$\mu\text{s}$
<b>Miscellaneous</b>						
$t_{detCL(TXEN\_BGE)}$	TXEN_BGE clamp detection time		2600	-	10400	$\mu\text{s}$

[1] Rise and fall time (10 % to 90 %) of  $t_{r(TXD)}$  and  $t_{f(TXD)} = 5\text{ ns} \pm 1\text{ ns}$ .

[2] Same parameter is guaranteed by design for the transition from Normal to Go-to-sleep mode.

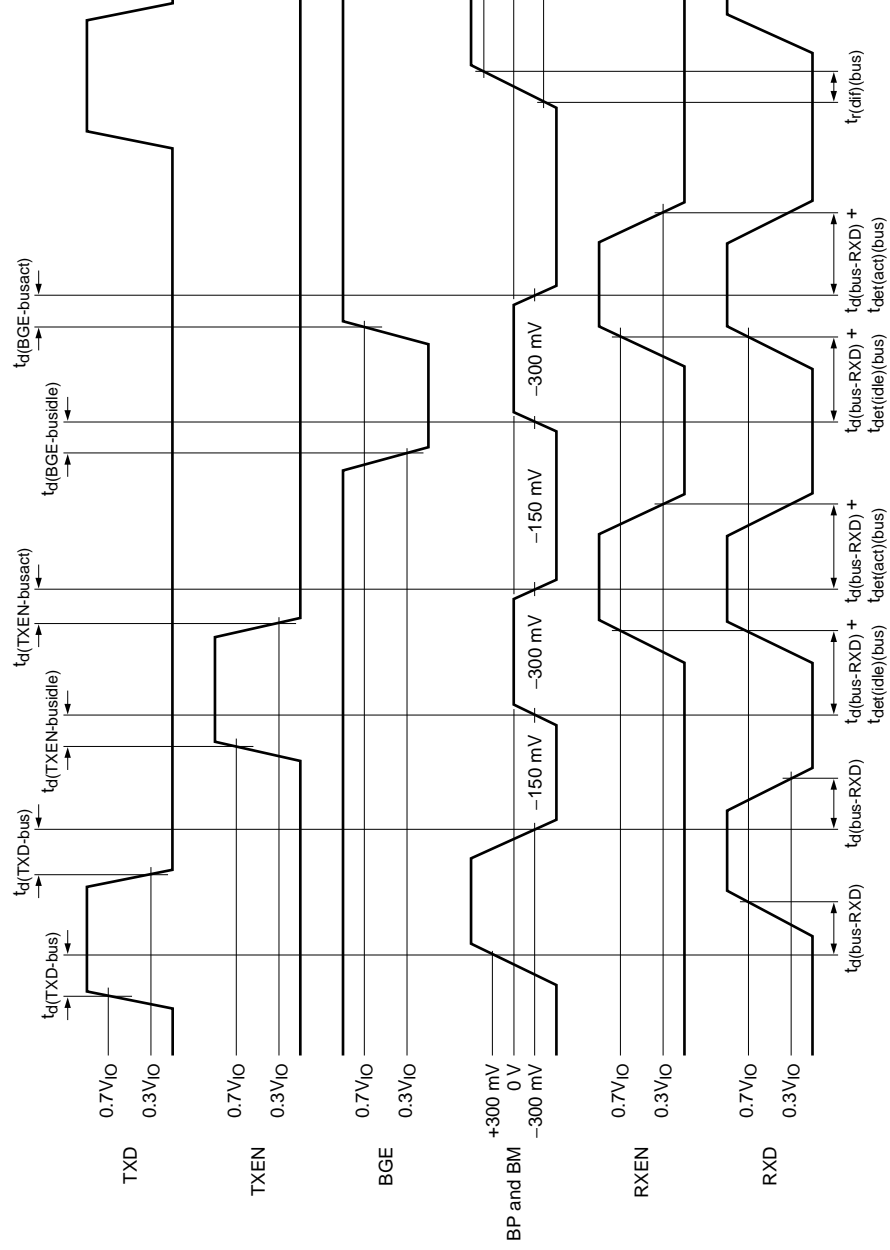

Fig 10. Detailed timing diagram

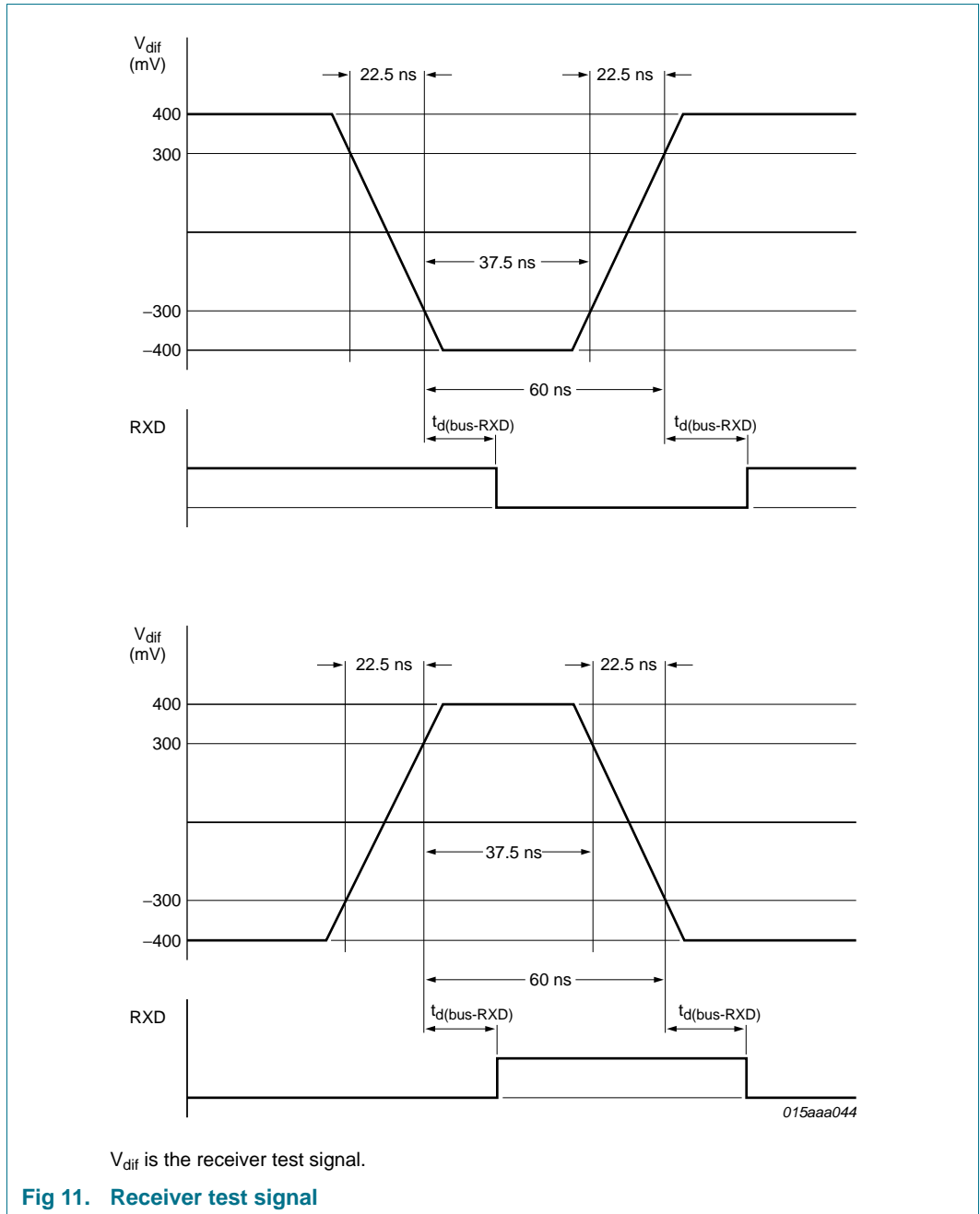

Fig 11. Receiver test signal

## 11. Test information

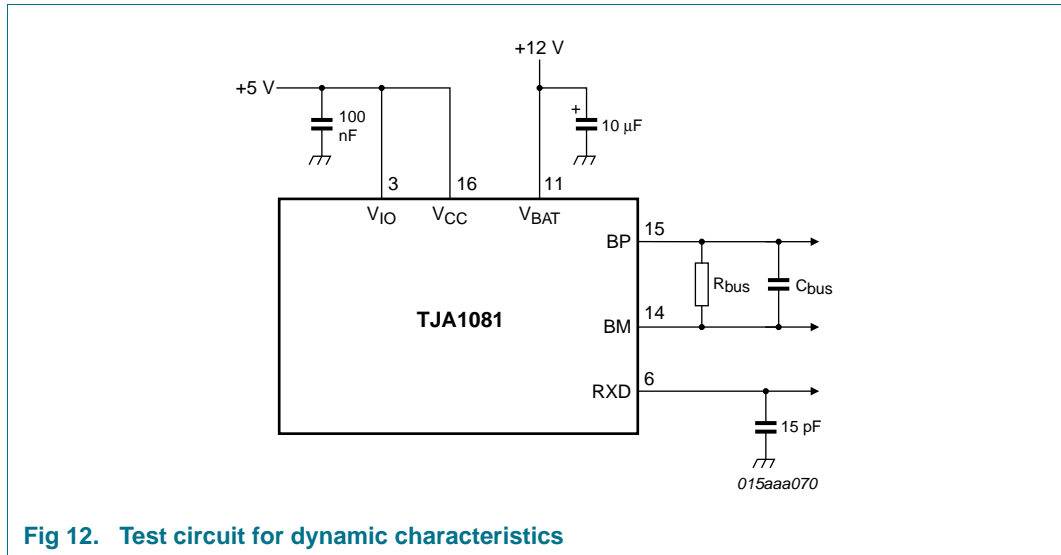

Fig 12. Test circuit for dynamic characteristics

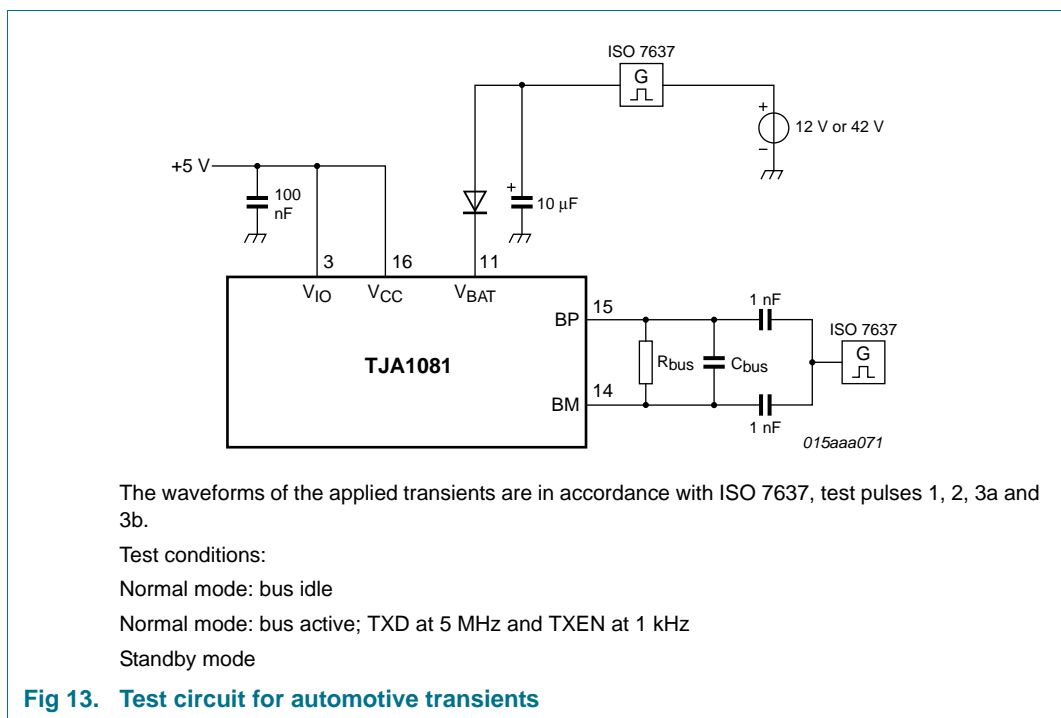

Fig 13. Test circuit for automotive transients

## 12. Package outline

SSOP16: plastic shrink small outline package; 16 leads; body width 5.3 mm

SOT338-1

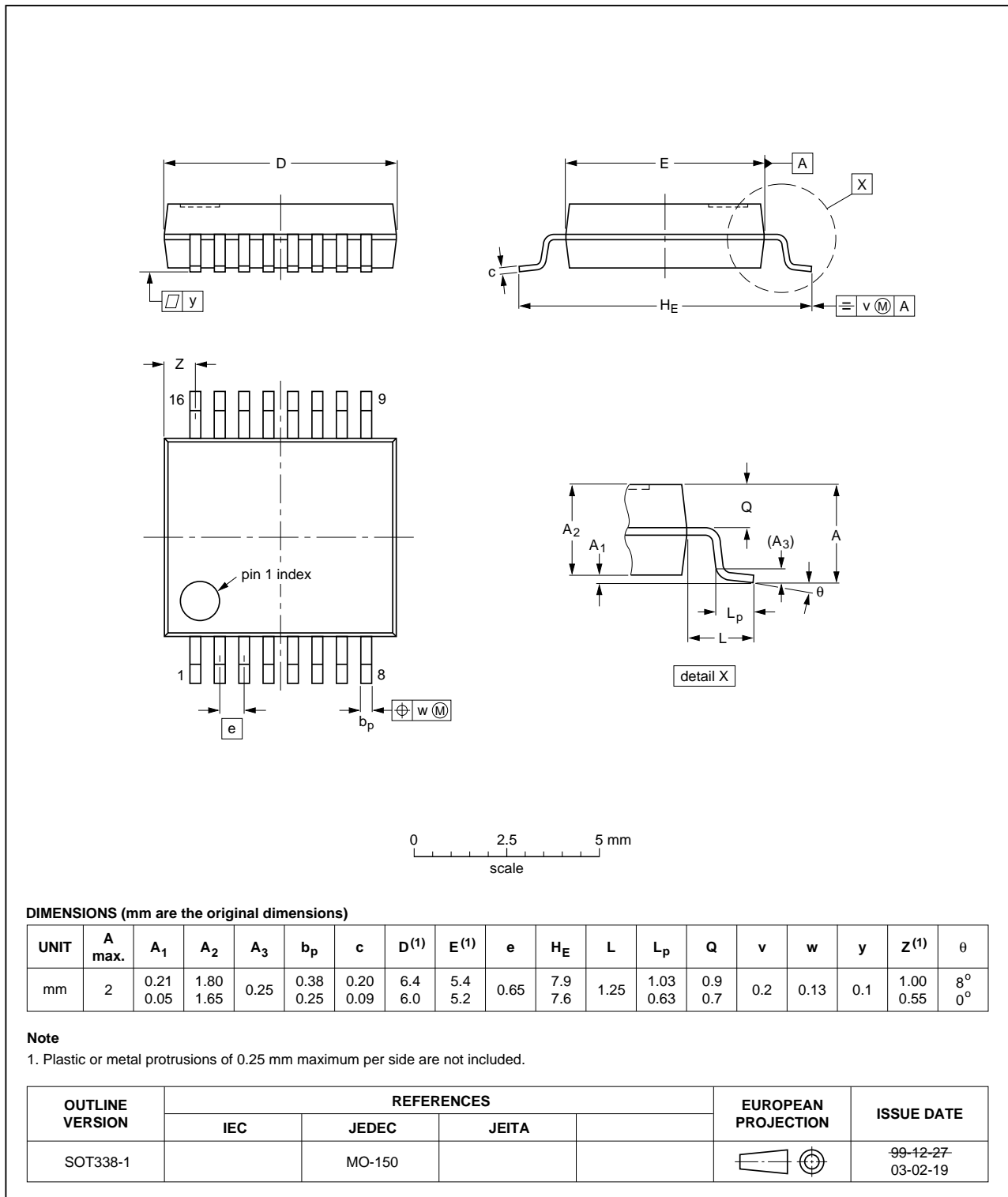

Fig 14. Package outline SOT338-1 (SSOP16)

## 13. Soldering of SMD packages

This text provides a very brief insight into a complex technology. A more in-depth account of soldering ICs can be found in Application Note *AN10365 "Surface mount reflow soldering description"*.

### 13.1 Introduction to soldering

Soldering is one of the most common methods through which packages are attached to Printed Circuit Boards (PCBs), to form electrical circuits. The soldered joint provides both the mechanical and the electrical connection. There is no single soldering method that is ideal for all IC packages. Wave soldering is often preferred when through-hole and Surface Mount Devices (SMDs) are mixed on one printed wiring board; however, it is not suitable for fine pitch SMDs. Reflow soldering is ideal for the small pitches and high densities that come with increased miniaturization.

### 13.2 Wave and reflow soldering

Wave soldering is a joining technology in which the joints are made by solder coming from a standing wave of liquid solder. The wave soldering process is suitable for the following:

- Through-hole components
- Leaded or leadless SMDs, which are glued to the surface of the printed circuit board

Not all SMDs can be wave soldered. Packages with solder balls, and some leadless packages which have solder lands underneath the body, cannot be wave soldered. Also, leaded SMDs with leads having a pitch smaller than ~0.6 mm cannot be wave soldered, due to an increased probability of bridging.

The reflow soldering process involves applying solder paste to a board, followed by component placement and exposure to a temperature profile. Leaded packages, packages with solder balls, and leadless packages are all reflow solderable.

Key characteristics in both wave and reflow soldering are:

- Board specifications, including the board finish, solder masks and vias
- Package footprints, including solder thieves and orientation
- The moisture sensitivity level of the packages
- Package placement
- Inspection and repair
- Lead-free soldering versus SnPb soldering

### 13.3 Wave soldering

Key characteristics in wave soldering are:

- Process issues, such as application of adhesive and flux, clinching of leads, board transport, the solder wave parameters, and the time during which components are exposed to the wave
- Solder bath specifications, including temperature and impurities

### 13.4 Reflow soldering

Key characteristics in reflow soldering are:

- Lead-free versus SnPb soldering; note that a lead-free reflow process usually leads to higher minimum peak temperatures (see [Figure 15](#)) than a SnPb process, thus reducing the process window
- Solder paste printing issues including smearing, release, and adjusting the process window for a mix of large and small components on one board
- Reflow temperature profile; this profile includes preheat, reflow (in which the board is heated to the peak temperature) and cooling down. It is imperative that the peak temperature is high enough for the solder to make reliable solder joints (a solder paste characteristic). In addition, the peak temperature must be low enough that the packages and/or boards are not damaged. The peak temperature of the package depends on package thickness and volume and is classified in accordance with [Table 14](#) and [15](#)

**Table 14. SnPb eutectic process (from J-STD-020C)**

Package thickness (mm)	Package reflow temperature (°C)	
	Volume (mm <sup>3</sup> )	
	< 350	≥ 350
< 2.5	235	220
≥ 2.5	220	220

**Table 15. Lead-free process (from J-STD-020C)**

Package thickness (mm)	Package reflow temperature (°C)		
	Volume (mm <sup>3</sup> )		
	< 350	350 to 2000	> 2000
< 1.6	260	260	260
1.6 to 2.5	260	250	245
> 2.5	250	245	245

Moisture sensitivity precautions, as indicated on the packing, must be respected at all times.

Studies have shown that small packages reach higher temperatures during reflow soldering, see [Figure 15](#).

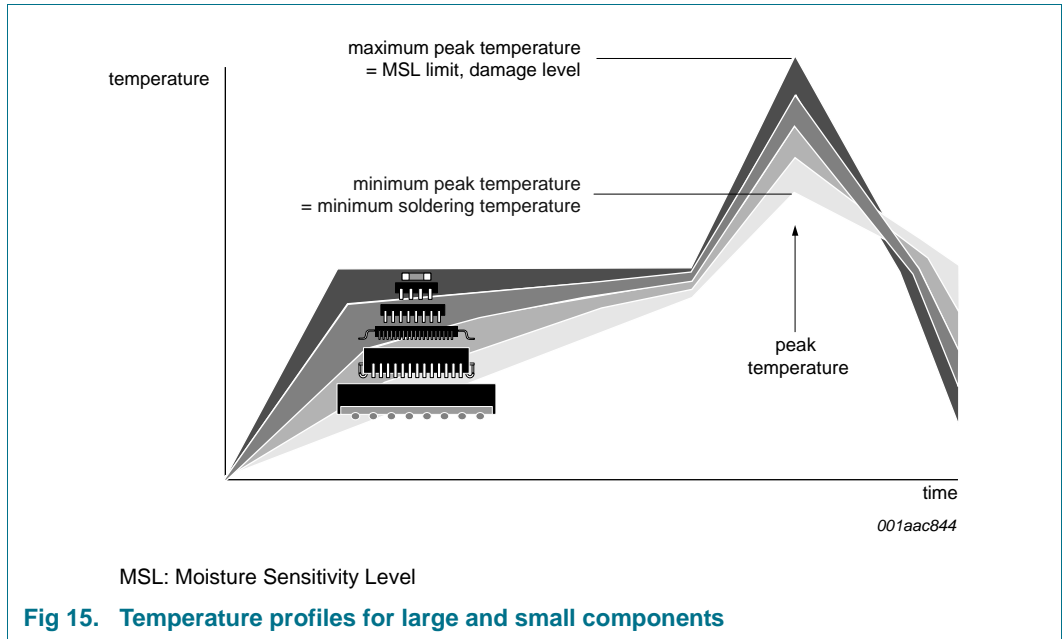

For further information on temperature profiles, refer to Application Note AN10365 “Surface mount reflow soldering description”.

## 14. Appendix

### 14.1 EPL 3.0.1 requirements implemented in the TJA1081

Table 16. EPL 3.0.1 requirements implemented

EPL 3.0.1 parameter	Description
-	wake-up via dedicated data frames
R <sub>DCLoad</sub>	transmitter output voltage defined for DC bus load of 40 Ω to 55 Ω/100 pF
dBDTx10, dBDTx01	transmitter delay: ≤ 75 ns
uData0_LP	receiver thresholds for detecting DATA_0 in low-power modes: -400 mV (min)/ -100 mV (max)
dBDRxai	idle reaction time: 50 ns to 275 ns
dBDAActivityDetection	activity detection time 100 ns to 250 ns
dBDRxia	activity reaction time: 100 ns to 325 ns
uData1 –  uData0	receiver threshold mismatch: ≤ 30 mV
dBDRx10, dBDRx01	receiver delay: ≤ 75 ns
dBusRx0BD, dBusRx1BD	minimum bit time: 70 ns
C_StarTxD, C_BDTxD	maximum input capacitance on pin TXD: 10 pF
dBDTxRxai	idle loop delay: ≤ 325 ns
-	BD_Off mode defined
	Short circuit currents:
iBP <sub>BMSHORTMax</sub> , iBM <sub>BPSHORTMax</sub>	BP shorted to BM: < 60 mA; no time limit
iBP <sub>GNDSHORTMax</sub> , iBM <sub>GNDSHORTMax</sub>	BP/BM shorted to ground: < 60 mA; no time limit
iBP <sub>-5SHORTMax</sub> , iBM <sub>-5SHORTMax</sub>	BP/BM shorted to -5 V: < 60 mA; no time limit
iBP <sub>BAT48SHORTMax</sub> , iBM <sub>BAT27SHORTMax</sub>	BP/BM shorted to 27 V: < 60 mA; no time limit
iBP <sub>BAT48SHORTMax</sub> , iBM <sub>BAT27SHORTMax</sub>	BP/BM shorted to 48 V: < 72 mA; no time limit
iBP <sub>BAT60SHORTMax</sub> , iBM <sub>BAT60SHORTMax</sub>	BP/BM shorted to 60 V: < 90 mA; for 400 ms (max)
dBDRV <sub>CC</sub>	V <sub>CC</sub> undervoltage recovery time: 10 ms (max)
uINH1 <sub>Not_Sleep</sub>	voltage drop from V <sub>BAT</sub> to INH: ≤ 1 V @ 200 μA and V <sub>BAT</sub> ≥ 5.5 V
iINH1 <sub>Leak</sub>	leakage current, when INH is floating: ≤ 10 μA
-	Qualification according to AEC-Q100 temperature classes
uESDExt	6 kV ESD (min) on pins BP and BM according to HBM (100 pF/1500 Ω)
uESDInt	2 kV ESD (min) on all other pins according to HBM (100 pF/1500 Ω)

## 15. Abbreviations

Table 17. Abbreviations

Abbreviation	Description
BSS	Byte Start Sequence
CDM	Charged Device Model
ECU	Electronic Control Unit
EMC	ElectroMagnetic Compatibility
EME	ElectroMagnetic Emission
EMI	ElectroMagnetic Immunity
ESD	ElectroStatic Discharge
HBM	Human Body Model
MM	Machine Model
TSS	Transmission Start Sequence

## 16. References

- [1] **EPL** — FlexRay Communications System Electrical Physical Layer Specification Version 2.1 Rev. A, FlexRay Consortium, Dec. 2005
- [2] **EPL** — FlexRay Communications System Electrical Physical Layer Specification Version 3.0.1, FlexRay Consortium
- [3] **TJA1080A** — FlexRay transceiver data sheet, www.nxp.com

## 17. Revision history

Table 18. Revision history

Document ID	Release date	Data sheet status	Change notice	Supersedes
TJA1081 v.5	20121128	Product data sheet	-	TJA1081 v.4
Modifications:	<ul style="list-style-type: none"> <li>• <a href="#">Section 6.2</a> : <math>V_{BAT}</math>, <math>V_{CC}</math> and <math>V_{IO}</math> operating ranges added</li> <li>• <a href="#">Table 10</a>: parameter values revised: <math>V_{BAT}</math>, <math>V_{CC}</math> and <math>V_{IO}</math></li> <li>• <a href="#">Table 12</a>: parameter values revised: <math>V_{IL(dif)}</math></li> </ul>			
TJA1081 v.4	20110224	Product data sheet	-	TJA1081 v.3
TJA1081 v.3	20090904	Product data sheet	-	TJA1081 v.2
TJA1081 v.2	20090728	Product data sheet	-	TJA1081 v.1
TJA1081 v.1	20090415	Preliminary data sheet	-	-

## 18. Legal information

### 18.1 Data sheet status

Document status <sup>[1][2]</sup>	Product status <sup>[3]</sup>	Definition
Objective [short] data sheet	Development	This document contains data from the objective specification for product development.
Preliminary [short] data sheet	Qualification	This document contains data from the preliminary specification.
Product [short] data sheet	Production	This document contains the product specification.

[1] Please consult the most recently issued document before initiating or completing a design.

[2] The term 'short data sheet' is explained in section "Definitions".

[3] The product status of device(s) described in this document may have changed since this document was published and may differ in case of multiple devices. The latest product status information is available on the Internet at URL <http://www.nxp.com>.

### 18.2 Definitions

**Draft** — The document is a draft version only. The content is still under internal review and subject to formal approval, which may result in modifications or additions. NXP Semiconductors does not give any representations or warranties as to the accuracy or completeness of information included herein and shall have no liability for the consequences of use of such information.

**Short data sheet** — A short data sheet is an extract from a full data sheet with the same product type number(s) and title. A short data sheet is intended for quick reference only and should not be relied upon to contain detailed and full information. For detailed and full information see the relevant full data sheet, which is available on request via the local NXP Semiconductors sales office. In case of any inconsistency or conflict with the short data sheet, the full data sheet shall prevail.

**Product specification** — The information and data provided in a Product data sheet shall define the specification of the product as agreed between NXP Semiconductors and its customer, unless NXP Semiconductors and customer have explicitly agreed otherwise in writing. In no event however, shall an agreement be valid in which the NXP Semiconductors product is deemed to offer functions and qualities beyond those described in the Product data sheet.

### 18.3 Disclaimers

**Limited warranty and liability** — Information in this document is believed to be accurate and reliable. However, NXP Semiconductors does not give any representations or warranties, expressed or implied, as to the accuracy or completeness of such information and shall have no liability for the consequences of use of such information. NXP Semiconductors takes no responsibility for the content in this document if provided by an information source outside of NXP Semiconductors.

In no event shall NXP Semiconductors be liable for any indirect, incidental, punitive, special or consequential damages (including - without limitation - lost profits, lost savings, business interruption, costs related to the removal or replacement of any products or rework charges) whether or not such damages are based on tort (including negligence), warranty, breach of contract or any other legal theory.

Notwithstanding any damages that customer might incur for any reason whatsoever, NXP Semiconductors' aggregate and cumulative liability towards customer for the products described herein shall be limited in accordance with the *Terms and conditions of commercial sale* of NXP Semiconductors.

**Right to make changes** — NXP Semiconductors reserves the right to make changes to information published in this document, including without limitation specifications and product descriptions, at any time and without notice. This document supersedes and replaces all information supplied prior to the publication hereof.

**Suitability for use in automotive applications** — This NXP Semiconductors product has been qualified for use in automotive applications. Unless otherwise agreed in writing, the product is not designed, authorized or warranted to be suitable for use in life support, life-critical or safety-critical systems or equipment, nor in applications where failure or malfunction of an NXP Semiconductors product can reasonably be expected to result in personal injury, death or severe property or environmental damage. NXP Semiconductors and its suppliers accept no liability for inclusion and/or use of NXP Semiconductors products in such equipment or applications and therefore such inclusion and/or use is at the customer's own risk.

**Applications** — Applications that are described herein for any of these products are for illustrative purposes only. NXP Semiconductors makes no representation or warranty that such applications will be suitable for the specified use without further testing or modification.

Customers are responsible for the design and operation of their applications and products using NXP Semiconductors products, and NXP Semiconductors accepts no liability for any assistance with applications or customer product design. It is customer's sole responsibility to determine whether the NXP Semiconductors product is suitable and fit for the customer's applications and products planned, as well as for the planned application and use of customer's third party customer(s). Customers should provide appropriate design and operating safeguards to minimize the risks associated with their applications and products.

NXP Semiconductors does not accept any liability related to any default, damage, costs or problem which is based on any weakness or default in the customer's applications or products, or the application or use by customer's third party customer(s). Customer is responsible for doing all necessary testing for the customer's applications and products using NXP Semiconductors products in order to avoid a default of the applications and the products or of the application or use by customer's third party customer(s). NXP does not accept any liability in this respect.

**Limiting values** — Stress above one or more limiting values (as defined in the Absolute Maximum Ratings System of IEC 60134) will cause permanent damage to the device. Limiting values are stress ratings only and (proper) operation of the device at these or any other conditions above those given in the Recommended operating conditions section (if present) or the Characteristics sections of this document is not warranted. Constant or repeated exposure to limiting values will permanently and irreversibly affect the quality and reliability of the device.

**Terms and conditions of commercial sale** — NXP Semiconductors products are sold subject to the general terms and conditions of commercial sale, as published at <http://www.nxp.com/profile/terms>, unless otherwise agreed in a valid written individual agreement. In case an individual agreement is concluded only the terms and conditions of the respective agreement shall apply. NXP Semiconductors hereby expressly objects to applying the customer's general terms and conditions with regard to the purchase of NXP Semiconductors products by customer.

**No offer to sell or license** — Nothing in this document may be interpreted or construed as an offer to sell products that is open for acceptance or the grant, conveyance or implication of any license under any copyrights, patents or other industrial or intellectual property rights.

**Export control** — This document as well as the item(s) described herein may be subject to export control regulations. Export might require a prior authorization from competent authorities.

## 18.4 Licenses

### NXP ICs with FlexRay functionality

This NXP product contains functionality that is compliant with the FlexRay specifications.

These specifications and the material contained in them, as released by the FlexRay Consortium, are for the purpose of information only. The FlexRay Consortium and the companies that have contributed to the specifications shall not be liable for any use of the specifications.

The material contained in these specifications is protected by copyright and other types of Intellectual Property Rights. The commercial exploitation of the material contained in the specifications requires a license to such Intellectual Property Rights.

These specifications may be utilized or reproduced without any modification, in any form or by any means, for informational purposes only. For any other purpose, no part of the specifications may be utilized or reproduced, in any form or by any means, without permission in writing from the publisher.

The FlexRay specifications have been developed for automotive applications only. They have neither been developed nor tested for non-automotive applications.

The word FlexRay and the FlexRay logo are registered trademarks.

## 18.5 Trademarks

Notice: All referenced brands, product names, service names and trademarks are the property of their respective owners.

## 19. Contact information

For more information, please visit: <http://www.nxp.com>

For sales office addresses, please send an email to: [salesaddresses@nxp.com](mailto:salesaddresses@nxp.com)

## 20. Contents

<b>1</b>	<b>General description</b> . . . . .	<b>1</b>	6.6	Status register . . . . .	17
<b>2</b>	<b>Features and benefits</b> . . . . .	<b>1</b>	<b>7</b>	<b>Limiting values</b> . . . . .	<b>19</b>
2.1	Optimized for time triggered communication systems . . . . .	1	<b>8</b>	<b>Thermal characteristics</b> . . . . .	<b>20</b>
2.2	Low power management . . . . .	1	<b>9</b>	<b>Static characteristics</b> . . . . .	<b>20</b>
2.3	Diagnosis (detection and signalling) . . . . .	2	<b>10</b>	<b>Dynamic characteristics</b> . . . . .	<b>24</b>
2.4	Protection . . . . .	2	<b>11</b>	<b>Test information</b> . . . . .	<b>28</b>
2.5	Functional classes according to FlexRay electrical physical layer specification (see <a href="#">Ref. 1</a> ) . . . . .	2	<b>12</b>	<b>Package outline</b> . . . . .	<b>29</b>
<b>3</b>	<b>Ordering information</b> . . . . .	<b>2</b>	<b>13</b>	<b>Soldering of SMD packages</b> . . . . .	<b>30</b>
<b>4</b>	<b>Block diagram</b> . . . . .	<b>3</b>	13.1	Introduction to soldering . . . . .	30
<b>5</b>	<b>Pinning information</b> . . . . .	<b>4</b>	13.2	Wave and reflow soldering . . . . .	30
5.1	Pinning . . . . .	4	13.3	Wave soldering . . . . .	30
5.2	Pin description . . . . .	4	13.4	Reflow soldering . . . . .	31
<b>6</b>	<b>Functional description</b> . . . . .	<b>5</b>	<b>14</b>	<b>Appendix</b> . . . . .	<b>33</b>
6.1	Operating modes . . . . .	5	14.1	EPL 3.0.1 requirements implemented in the TJA1081 . . . . .	33
6.1.1	Bus activity and idle detection . . . . .	5	<b>15</b>	<b>Abbreviations</b> . . . . .	<b>34</b>
6.2	Mode control pins: STBN and EN . . . . .	5	<b>16</b>	<b>References</b> . . . . .	<b>34</b>
6.2.1	Normal mode . . . . .	12	<b>17</b>	<b>Revision history</b> . . . . .	<b>34</b>
6.2.2	Receive-only mode . . . . .	12	<b>18</b>	<b>Legal information</b> . . . . .	<b>35</b>
6.2.3	Standby mode . . . . .	12	18.1	Data sheet status . . . . .	35
6.2.4	Go-to-sleep mode . . . . .	12	18.2	Definitions . . . . .	35
6.2.5	Sleep mode . . . . .	12	18.3	Disclaimers . . . . .	35
6.3	Wake-up mechanism . . . . .	13	18.4	Licenses . . . . .	36
6.3.1	Remote wake-up . . . . .	13	18.5	Trademarks . . . . .	36
6.3.1.1	Bus wake-up via wake-up pattern . . . . .	13	<b>19</b>	<b>Contact information</b> . . . . .	<b>36</b>
6.3.1.2	Bus wake-up via dedicated FlexRay data frame . . . . .	13	<b>20</b>	<b>Contents</b> . . . . .	<b>37</b>
6.3.2	Local wake-up via pin WAKE . . . . .	14			
6.4	Fail-silent behavior . . . . .	15			
6.4.1	V <sub>BAT</sub> undervoltage . . . . .	15			
6.4.2	V <sub>CC</sub> undervoltage . . . . .	15			
6.4.3	V <sub>IO</sub> undervoltage . . . . .	15			
6.5	Flags . . . . .	15			
6.5.1	Local wake-up source flag . . . . .	15			
6.5.2	Remote wake-up source flag . . . . .	16			
6.5.3	Wake flag . . . . .	16			
6.5.4	Power-on flag . . . . .	16			
6.5.5	Temperature medium flag . . . . .	16			
6.5.6	Temperature high flag . . . . .	16			
6.5.7	TXEN_BGE clamped flag . . . . .	16			
6.5.8	Bus error flag . . . . .	16			
6.5.9	UV <sub>V<sub>BAT</sub></sub> flag . . . . .	17			
6.5.10	UV <sub>V<sub>CC</sub></sub> flag . . . . .	17			
6.5.11	UV <sub>V<sub>IO</sub></sub> flag . . . . .	17			
6.5.12	Error flag . . . . .	17			

Please be aware that important notices concerning this document and the product(s) described herein, have been included in section 'Legal information'.

© NXP B.V. 2012.

All rights reserved.

For more information, please visit: <http://www.nxp.com>

For sales office addresses, please send an email to: [salesaddresses@nxp.com](mailto:salesaddresses@nxp.com)

Date of release: 28 November 2012

Document identifier: TJA1081

## Looking for pricing, stock, or lifecycle information?

Click below to explore more details on WIN SOURCE:

- ⊖ [View TJA1081TS,118 on WIN SOURCE](#)
- ⊖ [NXP / Nexperia Information](#)

## Optimize Your Supply Chain with WIN SOURCE Solutions

- ✓ Global Sourcing Solution
- ✓ Obsolete Management
- ✓ Cost Control Management
- ✓ Shortage Management
- ✓ Alternative Solution
- ✓ Excess Inventory Management