



**THE DATASHEET OF
TISP7015DR-S**



TRIPLE ELEMENT
THYRISTOR OVERVOLTAGE PROTECTORS



TISP7015 (VLV) Overvoltage Protector

Three Terminal Very Low Voltage (VLV) Protection

Ion-Implanted Breakdown Region
- Precise and Stable Voltage

DEVICE	V _{DRM} V	V _(BO) V
'7015	8	15

Protection for Signal, Data and Control Lines

- ISDN
- T1/E1
- RS232 & RS485

Low Capacitance 40 pF max.

Rated for International Surge Wave Shapes

Voltage Waveshape	Standard	I _{PPSM} A
8/20	IEC 61000-4-5	150
10/700	ITU-T K.20/45/21	40
10/1000	GR-1089-CORE	30

 UL Recognized Components

D Package (Top View)

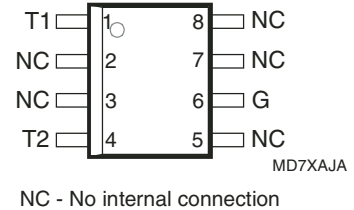

Device Symbol

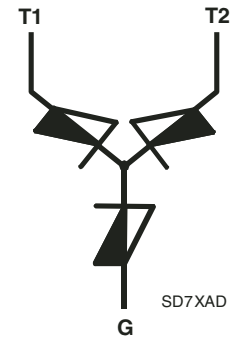

Description

The TISP7015 is a 3-point overvoltage protector designed for protecting against metallic (differential mode) and simultaneous longitudinal (common mode) impulses.

These devices are designed to limit overvoltages between signal, data and control port conductors, connected to terminals T1 and T2, and a protective ground, G. Each terminal pair has a symmetrical voltage-triggered bidirectional thyristor characteristic (Figure 1). Overvoltages are initially clipped by breakdown clamping until the voltage rises to the breakover level, which causes the device to crowbar into a low-voltage on state. This low-voltage on state causes the current resulting from the overvoltage to be safely diverted through the device. The device switches off when the diverted current falls below the holding current value.

Terminals marked NC do not have any internal connections and may be left floating or tied to some circuit point.

How To Order

Device	Package	Carrier	For Standard Termination Finish Order As	For Lead Free Termination Finish Order As
TISP7015	D, Small-outline	Embossed Tape Reeled	TISP7015DR	TISP7015DR-S
		Tube	TISP7015D	TISP7015D-S

*RoHS Directive 2002/95/EC Jan 27 2003 including Annex
JULY 2000 - REVISED FEBRUARY 2005
Specifications are subject to change without notice.
Customers should verify actual device performance in their specific applications.

TISP7015 (VLV) Overvoltage Protector

BOURNS®

Absolute Maximum Ratings, $T_J = 25\text{ }^\circ\text{C}$ (Unless Otherwise Noted)

Rating	Symbol	Value	Unit
Repetitive peak off-state voltage	V_{DRM}	± 8	V
Non-repetitive peak on-state pulse current (see Notes 1 and 2) 8/20 (IEC 61000-4-5, clause 7.2, R = 0, combination wave generator) 5/310 (ITU-T recommendation K.44, 10/700 generator used for K.20/45/21) 10/1000 (Telcordia GR-1089-CORE, 10/1000 voltage wave shape)	I_{PPSM}	150 40 30	A
Non-repetitive peak on-state current (see Notes 1, 2 and 3) 50/60 Hz, 1 s	I_{TSM}	4	A
Junction temperature	T_J	-40 to +150	$^\circ\text{C}$
Storage temperature range	T_{stg}	-65 to +150	$^\circ\text{C}$

- NOTES: 1. Initially, the TISP7015 must be in thermal equilibrium at the specified T_A . The surge may be repeated after the TISP7015 returns to its initial conditions.
2. These non-repetitive rated currents are peak values of either polarity.
3. Total return current, I_G , value.

Electrical Characteristics, $T_J = 25\text{ }^\circ\text{C}$ (Unless Otherwise Noted)

Parameter	Test Conditions	Min	Typ	Max	Unit
I_{DRM} Repetitive peak off-state current	$V_D = \pm V_{DRM}$			± 4	μA
$V_{(BO)}$ Breakover voltage	$dv/dt = \pm 250\text{ V/ms}$, $R_{SOURCE} = 300\ \Omega$			± 15	V
$I_{(BO)}$ Breakover current	$dv/dt = \pm 250\text{ V/ms}$, $R_{SOURCE} = 300\ \Omega$			± 100	mA
V_T On-state voltage	$I_T = \pm 5\text{ A}$, $t_W = 100\ \mu\text{s}$			± 4	V
I_H Holding current	$I_T = \pm 5\text{ A}$, $di/dt = +/- 30\text{ mA/ms}$	± 30			mA
I_D Off-state current	$V_D = \pm 0.85V_{DRM}$, $T_A = 85\text{ }^\circ\text{C}$			± 10	μA
C_{KA} Off-state capacitance	$f = 1\text{ MHz}$, $V_d = 30\text{ mV rms}$, $V_D = 0$ (see Note 4)		32	40	pF

NOTE 4: Three-terminal guarded measurement, unmeasured terminal voltage bias is zero.

Thermal Characteristics

Parameter	Test Conditions	Min	Typ	Max	Unit
$R_{\theta JA}$ Junction to free air thermal resistance	$P_{tot} = 0.8\text{ W}$, $T_A = 25\text{ }^\circ\text{C}$, 5 cm^2 , FR4 PCB			160	$^\circ\text{C/W}$

Parameter Measurement Information

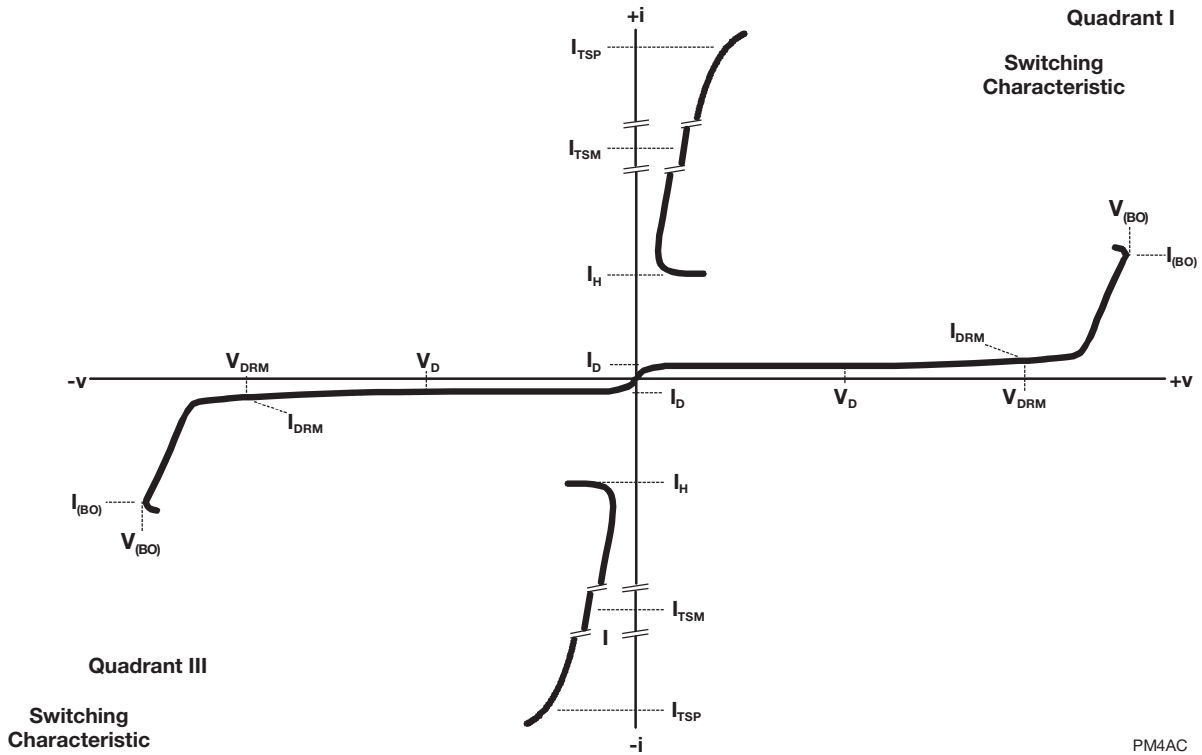

PM4AC

Figure 1. Voltage-Current Characteristic for any Terminal Pair

TISP7015 (VLV) Overvoltage Protector



MECHANICAL DATA

Device Symbolization Code

Devices will be coded as below.

Device	Symbolization Code
TISP7015	7015

TISP7015 (VLV) Overvoltage Protector

BOURNS®

MECHANICAL DATA

D008 Plastic Small-outline Package

This small-outline package consists of a circuit mounted on a lead frame and encapsulated within a plastic compound. The compound will withstand soldering temperature with no deformation, and circuit performance characteristics will remain stable when operated in high humidity conditions. Leads require no additional cleaning or processing when used in soldered assembly.

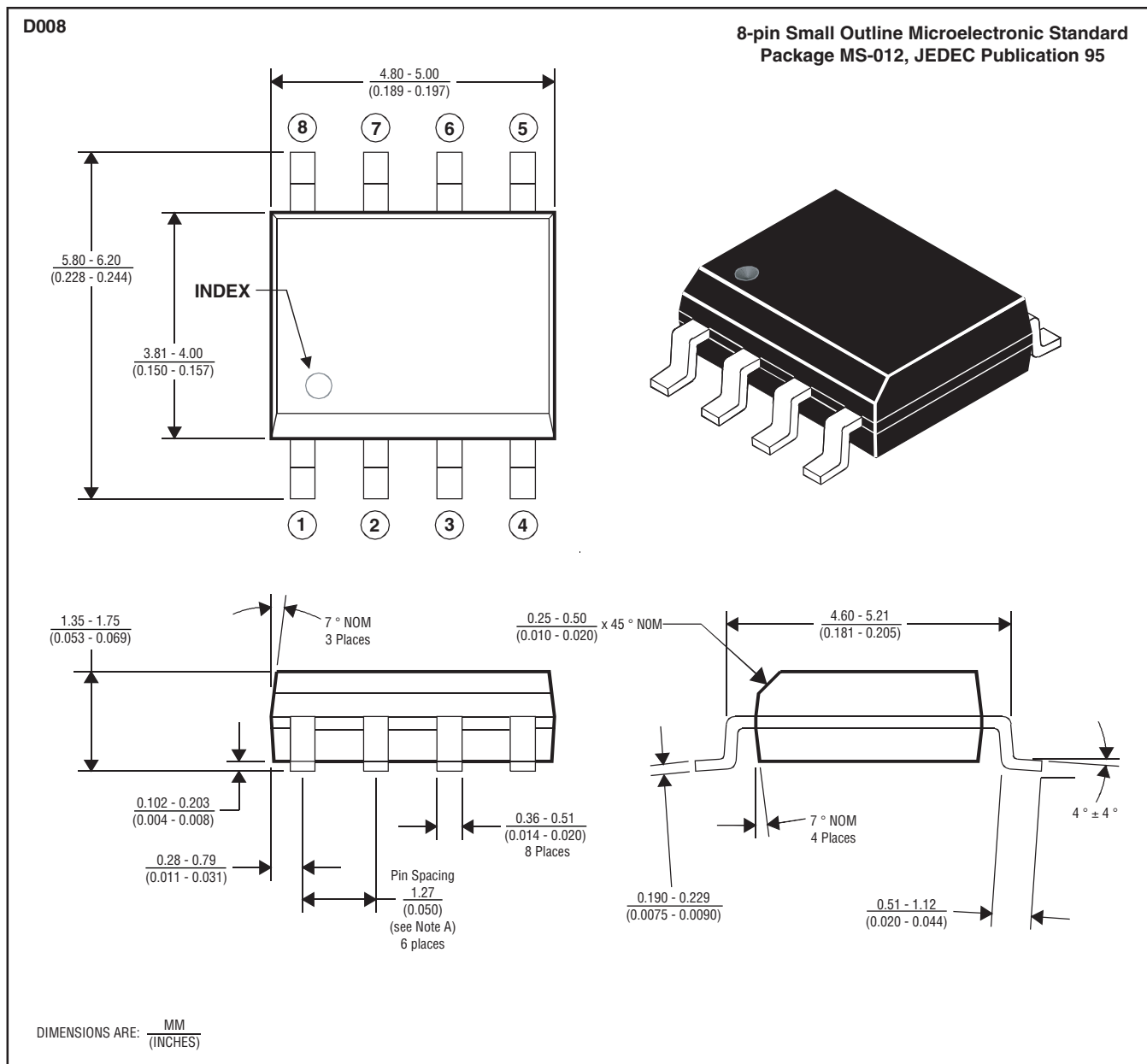

- NOTES: A. Leads are within 0.25 (0.010) radius of true position at maximum material condition.
 B. Body dimensions do not include mold flash or protrusion.
 C. Mold flash or protrusion shall not exceed 0.15 (0.006).
 D. Lead tips to be planar within ± 0.051 (0.002).

MDXXAAE

JULY 2000 - REVISED FEBRUARY 2005
 Specifications are subject to change without notice.
 Customers should verify actual device performance in their specific applications.

TISP7015 (VLV) Overvoltage Protector

BOURNS®

MECHANICAL DATA

D008 Tape Dimensions

D008 Package (8-pin Small Outline) Single-Sprocket Tape

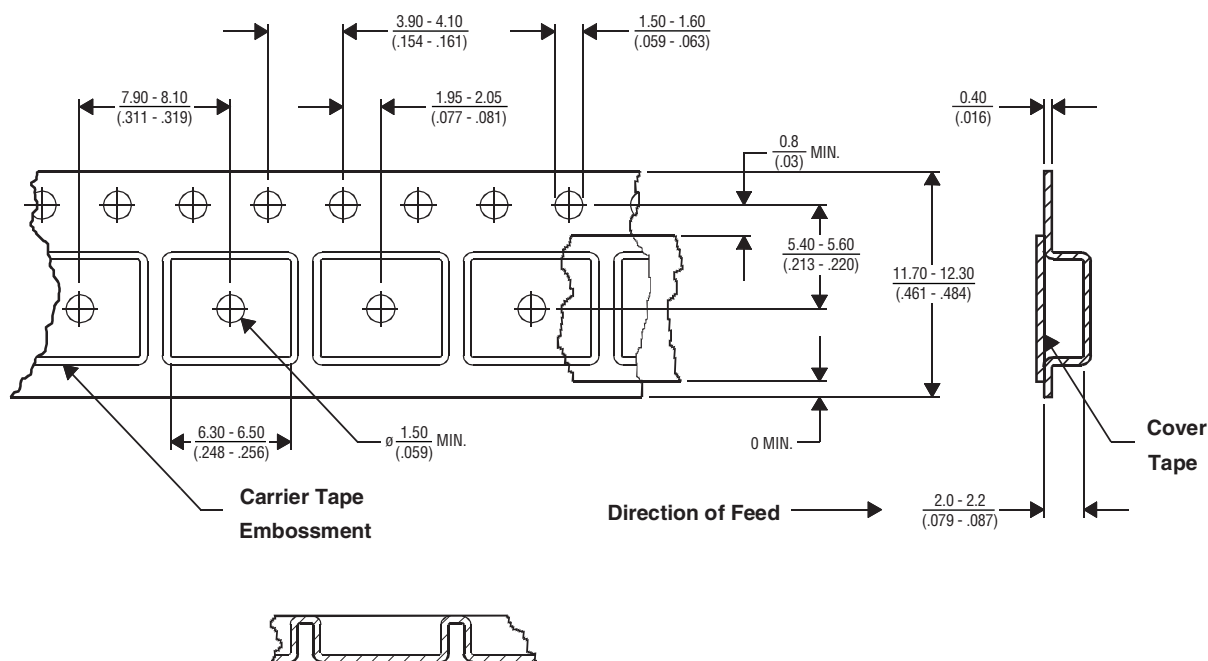

DIMENSIONS ARE: $\frac{\text{MM}}{\text{(INCHES)}}$

NOTES: A. Taped devices are supplied on a reel of the following dimensions:-

MDXXATC

Reel diameter:	$\frac{330 \pm 0.0 / -4.0}{(12.99 \pm 0.0 / -0.157)}$
Reel hub diameter:	$\frac{100 \pm 2.0}{(3.937 \pm 0.079)}$
Reel axial hole:	$\frac{13.0 \pm 0.2}{(0.512 \pm 0.008)}$



B. 2500 devices are on a reel.

"TISP" is a trademark of Bourns, Ltd., a Bourns Company, and is Registered in U.S. Patent and Trademark Office.
"Bourns" is a registered trademark of Bourns, Inc. in the U.S. and other countries.

JULY 2000 - REVISED FEBRUARY 2005
Specifications are subject to change without notice.
Customers should verify actual device performance in their specific applications.

Looking for pricing, stock, or lifecycle information?

Click below to explore more details on WIN SOURCE:

-  [View TISP7015DR-S on WIN SOURCE](#)
-  [Bourns Inc. Information](#)

Optimize Your Supply Chain with WIN SOURCE Solutions

-  Global Sourcing Solution
-  Obsolete Management
-  Cost Control Management
-  Shortage Management
-  Alternative Solution
-  Excess Inventory Management